



Distribution Operations

|                               |   |  |
|-------------------------------|---|--|
| Effective Date:<br>10/13/2014 | <b>Transmission Lines and Distribution Mains<br/>Directional Boring</b> | Standard Number:<br><b>GS 3010.102</b> |
| Supersedes:<br>07/01/2012     |   | Page 1 of 5                            |

Companies Affected:

|  |   |   |
|--|---|---|
| <input checked="" type="checkbox"/> NIPSCO | <input type="checkbox"/> CGV            | <input checked="" type="checkbox"/> CMD |
|  | <input checked="" type="checkbox"/> CKY | <input checked="" type="checkbox"/> COH |
|  | <input checked="" type="checkbox"/> CMA | <input checked="" type="checkbox"/> CPA |

**1. GENERAL**

This standard covers installation practices for steel and plastic pipelines and casing by the directional boring method, also known as horizontal directional drilling. This method is ideally suited for soft subsoils such as clay and compacted sand. Subgrade soils consisting of large grain materials (e.g. gravel and cobble), rock, and buried debris make it more difficult to use directional drilling and may contribute to damage to the pipe and drilling equipment.

For general requirements and guidelines pertaining to directional boring, refer to Gas Standard GS 3010.100 "Trenchless Technology."

For damage prevention guidelines associated with the use of directional boring, refer to Gas Standard GS 1100.050 "Damage Prevention – Using Trenchless Technology."

The Company's Representative, whether employee or contractor:

- a. shall inspect each project/job site to ensure that all work complies with Company procedures and is done in accordance with all governmental regulations; and
- b. has the authority to order the removal or correction of any portion of construction, welds, fusions, mechanical joints, coatings, backfill, etc. that do not meet the Company's requirements.

**2. SITE PREPARATION**

The bore (drill) path should be as straight as possible to minimize friction during pull back, and to maximize the length of pipe that can be installed in a single pull. Straight bore paths are especially important for pipe sizes above eight (8) inches and for pull lengths greater than 400 feet.

NiSource Gas Distribution (NGD) companies should refer to Health, Safety, and Environmental procedure HSE 4100.040 "Excavation (Trenching) Safety" for excavation requirements. NIPSCO should refer to their applicable Safety Manual rules.

Steps should be taken to keep the drilling fluids out of the streets, manholes, sanitary and storm sewers, and other drainage systems, including rivers and streams.

*This document is considered CONTROLLED only when viewed electronically on the Company's intranet. Printed or other electronic copies may not be current, and the intranet version should be used to verify.*



Distribution Operations

|                               |   |  |
|-------------------------------|---|--|
| Effective Date:<br>10/13/2014 | <b>Transmission Lines and Distribution Mains<br/>Directional Boring</b> | Standard Number:<br><b>GS 3010.102</b> |
| Supersedes:<br>07/01/2012     |   | Page 2 of 5                            |

**3. DRILLING OPERATION**

Drilling should progress from a higher elevation to a lower one to help ensure that the drill mud remains in the hole.

The proper minimum depth of cover and clearances from crossing utilities must be maintained by tracking the drilling head. Refer to Gas Standards 3010.090 "Cover" and 3010.090 "Underground Clearance."

Appropriate guidance equipment for steering and maintaining accurate location (tracking) of the drilling head shall be used during all drilling operations. Accurate measurements of the location and orientation of the drill head should be made while the drilling operation is halted to add or remove a length of drill rod.

Small diameter piping may be pulled back through the initial bore hole. Larger diameter piping will require first drilling a pilot hole throughout the bore to provide a path for the back-reaming operation. Back-reaming will allow the smooth passage of the pipe as it is pulled through the bore hole. Multiple passes with progressively larger reamers may be required. For eight (8)-inch pipe and less, the back-ream hole should be between 1-1/2 and 2 times the size of the pipe to be pulled through. For pipe larger than eight (8) inches, the back-ream hole should be at least six (6) inches greater in diameter. In sandy soil, the diameter of the back ream hole may need to be at most two (2) times the diameter of the pipe.

**4. PIPE INSTALLATION**

For plastic pipe installations, coiled pipe should be used for directional boring if available. All plastic pipe joints to be passed into the bore hole shall be made by butt-fusion. An appropriate size tracer wire with yellow jacketing shall be attached to the leading end of the pipe or to the pulling head prior to commencing the pull-in operation. Due to the extra stress that may be encountered during pull-in, AWG #8 through #12 solid or stranded copper wire is recommended and should be selected based on anticipated stresses during installation. It is recommended that wire connections be made using silicone filled wire connectors approved for direct burial.

For steel pipe installations, a qualified welder shall be used to weld all joints. All joints on pipelines that require nondestructive testing shall be tested according to Gas Standard GS 1210.010 "Nondestructive Testing." All joints shall be coated with the proper coating material according to the Corrosion Control standards.

In locations where the pipe cannot easily be excavated, it is recommended that the pipe be given a leak test prior to installation. Pressure test of the pipe is still necessary per Gas Standard GS 1500.010 "Pressure Testing" after installation has been completed.

The maximum length of pipe that can be pulled in at one time depends on the:



Distribution Operations

|                               |   |  |
|-------------------------------|---|--|
| Effective Date:<br>10/13/2014 | <b>Transmission Lines and Distribution Mains<br/>Directional Boring</b> | Standard Number:<br><b>GS 3010.102</b> |
| Supersedes:<br>07/01/2012     |   | Page 3 of 5                            |

- a. amount of friction developed between the pipe and mud;
- b. drag of the pipe on the ground, skids, or other support; and
- c. contour of the bore.

During pullback, the stress on plastic should be not greater than 1/2 (50%) of the stress that would yield the pipe. For more information on maximum pulling forces for plastic pipe, see Exhibit A "Allowed Pulling Force for Plastic Pipe." See Gas Standard GS 3010.060 "Installation of Plastic Pipe" for additional precautions to be taken when pulling back plastic pipe.

The leading end of the pipe shall be capped to prevent water, drilling fluids, and other foreign materials from entering the pipe as it is pulled back.

Precautions shall be taken to protect the pipe from damage, eliminate ground drag, and reduce the pull-in force as it is being pulled into the bore hole. Rollers or other protective devices should be used to prevent damage to the pipe from the edges of the pit or substructure.

**5. POST-INSTALLATION INSPECTION**

After plastic pipe is pulled back, it shall be examined for scratches, scores, gouges, cuts, and other damage. Pipe with continuous damage in the axial direction that is more than 10% of the wall thickness of the pipe is not usable and re-boring is recommended. Additionally, any similar damage limited to the leading end of the pulled back pipe, with no evidence of damage afterwards, shall be cut off and the remaining pipe used.

Tracer wire shall be checked for continuity with a pipeline locator in areas where practical, and especially by attaching the locator to one end of the bore and locating the other end. Where the tracer wire is found to not be locatable, accurate measurements to permanent references shall be recorded on the project completion sketch to permit the piping to be located in the future. The placement of additional pipeline markers should also be considered.

Any coating damage on exposed steel piping shall be repaired according to the Corrosion Control Gas Standard GS 1420.040 "Repair Methods for Mill Applied Coatings."

The pipe should be pigged after being installed to ensure that it is clean and dry.

**6. RECORDS**

Follow all pipe installation recording requirements according to Gas Standard GS 3010.050 "Installation of Pipe in a Ditch" and GS 3010.060 "Installation of Plastic Pipe."



**Gas Standard**

Distribution Operations

|                               |   |  |
|-------------------------------|---|--|
| Effective Date:<br>10/13/2014 | <b>Transmission Lines and Distribution Mains<br/>Directional Boring</b> | Standard Number:<br><b>GS 3010.102</b> |
| Supersedes:<br>07/01/2012     |   | Page 4 of 5                            |

Additional information specific to the directional bore shall be included with the completion report to be retained in the Company's files for the life of the pipeline. Examples of such information are:

- a. Geological data,
- b. Any contractor bore calculations, or
- c. Location and depth, especially where the tracer wire cannot be located.





Distribution Operations

|                               |   |  |
|-------------------------------|---|--|
| Effective Date:<br>10/13/2014 | <b>Transmission Lines and Distribution Mains<br/>Directional Boring</b> | Standard Number:<br><b>GS 3010.102</b> |
| Supersedes:<br>07/01/2012     |   | Page 5 of 5                            |

**Exhibit A**

**Allowed Pulling Force for Plastic Pipe**

The allowed pulling force for each size of plastic pipe is determined by the tensile strength of the resin used to make the pipe and its cross-sectional area. The tensile strength for medium-density polyethylene (yellow) is approximately 2800 psi. The tensile strength for high-density polyethylene (black) is approximately 3200 psi. The allowed pulling forces for yellow and black plastic pipe are shown in Tables A1 and A2, respectively. The allowed pulling force is calculated to be 50% of the force required to yield the pipe.

**Table A1 – Maximum Pulling Force for Medium-Density Plastic Pipe (Yellow)**

| Pipe Size (Wall)  | OD<br>[inches] | ID<br>[inches] | Wall<br>Thickness<br>[inches] | Cross<br>Sectional<br>Area<br>[sq in] | Yield Pulling<br>Force<br>[lbs] | Allowed<br>Pulling Force<br>[lbs] |
|-------------------|----------------|----------------|-------------------------------|---------------------------------------|---------------------------------|-----------------------------------|
| 1/2" CTS (0.090") | 0.625          | 0.445          | 0.090                         | 0.151                                 | 424                             | 212                               |
| 1" CTS (0.099")   | 1.125          | 0.927          | 0.099                         | 0.319                                 | 893                             | 447                               |
| 2" IPS (SDR-11)   | 2.375          | 1.943          | 0.216                         | 1.465                                 | 4,101                           | 2,051                             |
| 3" IPS (SDR-11.5) | 3.500          | 2.891          | 0.304                         | 3.055                                 | 8,555                           | 4,278                             |
| 4" IPS (SDR-11.5) | 4.500          | 3.717          | 0.391                         | 5.051                                 | 14,143                          | 7,072                             |
| 6" IPS (SDR-11.5) | 6.625          | 5.473          | 0.576                         | 10.948                                | 30,653                          | 15,327                            |
| 6" IPS (SDR-13.5) | 6.625          | 5.644          | 0.491                         | 9.457                                 | 26,480                          | 13,240                            |
| 8" IPS (SDR-13.5) | 8.625          | 7.347          | 0.639                         | 16.029                                | 44,882                          | 22,441                            |

**Table A2 – Maximum Pulling Force for High-Density Plastic Pipe (Black)**

| Pipe Size (Wall)  | OD<br>[inches] | ID<br>[inches] | Wall<br>Thickness<br>[inches] | Cross<br>Sectional<br>Area<br>[sq in] | Yield Pulling<br>Force<br>[lbs] | Allowed<br>Pulling Force<br>[lbs] |
|-------------------|----------------|----------------|-------------------------------|---------------------------------------|---------------------------------|-----------------------------------|
| 1/2" CTS (0.090") | 0.625          | 0.445          | 0.090                         | 0.151                                 | 484                             | 242                               |
| 1" CTS (0.101")   | 1.125          | 0.923          | 0.101                         | 0.325                                 | 1,040                           | 520                               |
| 2" IPS (SDR-11)   | 2.375          | 1.943          | 0.216                         | 1.465                                 | 4,686                           | 2,343                             |
| 3" IPS (SDR-11)   | 3.500          | 2.864          | 0.318                         | 3.181                                 | 10,178                          | 5,089                             |
| 4" IPS (SDR-11)   | 4.500          | 3.682          | 0.409                         | 5.258                                 | 16,824                          | 8,412                             |
| 6" IPS (SDR-11)   | 6.625          | 5.420          | 0.602                         | 11.396                                | 36,466                          | 18,233                            |
| 8" IPS (SDR-11)   | 8.625          | 7.057          | 0.784                         | 19.314                                | 61,806                          | 30,903                            |



Distribution Operations

|                               |   |  |
|-------------------------------|---|--|
| Effective Date:<br>03/01/2010 | <b>Transmission Lines and Distribution Mains<br/>Augering with Casing</b> | Standard Number:<br><b>GS 3010.104</b> |
| Supersedes:<br>N/A            |   | Page 1 of 1                            |

Companies Affected:

|   |   |   |
|---|---|---|
| <input checked="" type="checkbox"/> NIPSCO<br>Effective: 06/01/2012 | <input checked="" type="checkbox"/> CGV | <input checked="" type="checkbox"/> CMD |
|   | <input checked="" type="checkbox"/> CKY | <input checked="" type="checkbox"/> COH |
|   | <input checked="" type="checkbox"/> CMA | <input checked="" type="checkbox"/> CPA |

**REFERENCE** N/A

**1. GENERAL**

This standard covers boring by augering while pushing a casing with the auger. When augering without casing, refer to Gas Standard GS 3010.106, "Other Boring Methods".

Refer to Gas Standard GS 3010.070, "Casing" for details related to the casing.

Refer to Gas Standard GS 1100.050, "Damage Prevention - Using Trenchless Technology" for safety measures prior and during any boring operation.

The Company's Representative, whether employee or contractor:

- a. shall inspect each project/job site to ensure that all work complies with Company procedures and is done in accordance with all governmental regulations; and
- b. has the authority to order the removal or correction of any portion of construction, welds, fusions, mechanical joints, coatings, backfill, etc. that do not meet the Company's requirements.

**2. AUGERING**

To minimize caving when case boring, the boring head is generally within three (3) inches of the leading edge of the casing. The casing and auger are to be steadily advanced as one unit. To ensure a void is not created when boring, the amount of dirt removed should be in proportion to the amount of advance. When case boring in broken rock or gravel, it is recommended to advance the head more than three (3) inches up to not more than 1/2 the diameter of the casing to allow the rock particles to enter through the screw flight.

Permitting for the bore may require modification to the above conditions or additional conditions to be followed.

**3. RECORDS**

All pipe installation recording requirements shall be followed according to Gas Standard GS 3010.050, "Installation of Pipe in a Ditch" and GS 3010.060, "Installation of Plastic Pipe."

*This document is considered CONTROLLED only when viewed electronically on the Company's intranet. Printed or other electronic copies may not be current, and the intranet version should be used to verify.*



Distribution Operations

|                               |   |  |
|-------------------------------|---|--|
| Effective Date:<br>03/01/2010 | <b>Transmission Lines and Distribution Mains<br/>Other Boring Methods</b> | Standard Number:<br><b>GS 3010.106</b> |
| Supersedes:<br>N/A            |   | Page 1 of 2                            |

Companies Affected:

|   |   |   |
|---|---|---|
| <input checked="" type="checkbox"/> NIPSCO<br>Effective: 06/01/2012 | <input checked="" type="checkbox"/> CGV | <input checked="" type="checkbox"/> CMD |
|   | <input checked="" type="checkbox"/> CKY | <input checked="" type="checkbox"/> COH |
|   | <input checked="" type="checkbox"/> CMA | <input checked="" type="checkbox"/> CPA |

**REFERENCE** N/A

**1. GENERAL**

This standard covers general straight-line methods for boring, including pneumatic hammering and rod driving, mainly to cross streets and other hard-surface areas. Boring by guided directional boring is covered by Gas Standard GS 3010.102, "Directional Boring." Specifics to cased boring by augering is covered by Gas Standard GS 3010.104, "Augering with Casing." General trenchless technology requirements are covered by Gas Standard GS 3010.100, "Trenchless Technology."

Refer to Gas Standard GS 1100.050, "Damage Prevention - Using Trenchless Technology" for safety measures prior and during any boring operation.

The Company's Representative, whether employee or contractor:

- a. shall inspect each project/job site to ensure that all work complies with Company procedures and is done in accordance with all governmental regulations; and
- b. has the authority to order the removal or correction of any portion of construction, welds, fusions, mechanical joints, coatings, backfill, etc. that do not meet the Company's requirements.

**2. BORING AND PIERCING**

When using a pneumatic hammering (piercing) tool, consideration should be given to secondary damage caused by pressure exerted on any paved surface by soil displacement or the tool's tendency to surface when encountering diversionary obstructions.

When boring without casing, the diameter and condition of the bore hole shall be such that the pipe or coating is not damaged when inserted. If significant damage to the pipe or coating is likely, the bore hole shall be enlarged or the pipe encased.

The annular space between the pipe and the bore hole shall be kept to a minimum to prevent caving. The following bore hole sizes apply.

- a. For 3" and smaller pipe, the bore hole should be no greater than 5 inches in

*This document is considered CONTROLLED only when viewed electronically on the Company's intranet. Printed or other electronic copies may not be current, and the intranet version should be used to verify.*



Distribution Operations

|                               |   |  |
|-------------------------------|---|--|
| Effective Date:<br>03/01/2010 | <b>Transmission Lines and Distribution Mains<br/>Other Boring Methods</b> | Standard Number:<br><b>GS 3010.106</b> |
| Supersedes:<br>N/A            |   | Page 2 of 2                            |

diameter.

- b. For 4" and larger pipe or casing, the bore hole should be no greater than the next larger pipe size.

The field operations leader or contractor inspector must approve exceptions.

Unsuccessful bore holes 6 inches and larger which could cave, shall be filled. All unsuccessful bore holes required by the permit shall be filled.

**3. RECORDS**

All pipe installation recording requirements shall be followed according to Gas Standard GS 3010.050, "Installation of Pipe in a Ditch" and GS 3010.060, "Installation of Plastic Pipe."

The details of all unsuccessful bores shall be recorded with the work completion report. Some of the details to record are:

- a. the number of unsuccessful bores;
- b. the method of bore;
- c. the diameter and location of each unsuccessful bore; and
- d. whether each unsuccessful bore was filled, and if so with what material including any tooling left in the bore.



**Gas Standard**

|                               |                                  |  |
|-------------------------------|----------------------------------|--|
| Effective Date:<br>05/14/2014 | <b>Service Line Installation</b> | Standard Number:<br><b>GS 3020.010</b> |
| Supersedes:<br>10/10/2012     |                                  | Page 1 of 7                            |

Companies Affected:

|                                 |   |   |
|---------------------------------|---|---|
| <input type="checkbox"/> NIPSCO | <input type="checkbox"/> CGV            | <input checked="" type="checkbox"/> CMD |
|                                 | <input checked="" type="checkbox"/> CKY | <input checked="" type="checkbox"/> COH |
|                                 | <input checked="" type="checkbox"/> CMA | <input checked="" type="checkbox"/> CPA |

**REFERENCE** 49 CFR 192.361

**1. GENERAL**

This standard covers the general requirements and considerations for installation of service lines.

When installing a new service line or replacing an existing service line, the proximity and condition of existing conduits, ducts, sewer lines, and similar structures, including abandoned structures, should be considered since they have the potential to provide a path for the migration of leaking gas.

Further, consideration should be given to avoiding the installation of service lines in close proximity to specific types of trees or shrubs that have the potential for extensive root growth, particularly those that are less mature. Future root growth could exert forces on the pipe and nearby joints.

The Company's Representative, whether employee or contractor:

- a. shall inspect each project/job site to ensure that all work complies with Company procedures and is done in accordance with all governmental regulations; and
- b. has the authority to order the removal or correction of any portion of construction, welds, fusions, mechanical joints, coatings, backfill, etc. that do not meet the Company's requirements.

**2. INSTALLATION REQUIREMENTS**

The service line should be installed from the main in a perpendicular, continuous straight line to either the connection of the riser or where the piping enters the outer masonry wall of a building below grade.

A service line may be installed to an individual customer, to two adjacent or adjoining residential or small commercial customers, or to multiple residential or small commercial customers served through a meter header or manifold.

Servicing two adjacent customers can be accomplished by installing a split or branch service line from another service line. The branching of split services should be on the road or gas main right-of-way prior to entering the private property of the customer. It is preferred to

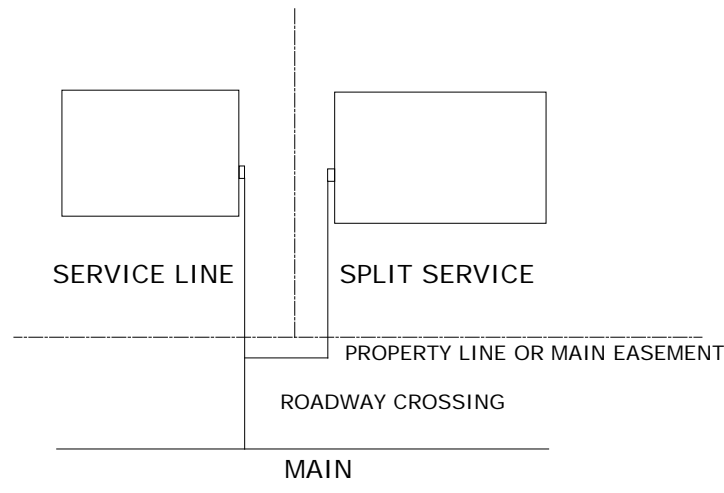
*This document is considered CONTROLLED only when viewed electronically on the Company's intranet. Printed or other electronic copies may not be current, and the intranet version should be used to verify.*

|                               |                                  |  |
|-------------------------------|----------------------------------|--|
| Effective Date:<br>05/14/2014 | <b>Service Line Installation</b> | Standard Number:<br><b>GS 3020.010</b> |
| Supersedes:<br>10/10/2012     |                                  | Page 2 of 7                            |

install the service from the main straight to one of the customers, with the branch to the other customer, as illustrated by Sketch 1, to facilitate location of the service line. A split service may be advantageous for long roadway crossings to avoid installing separate services under the roadway. Individual service lines should be installed when not crossing under a roadway unless there are other advantages to installing a split service. Other considerations for installing split service lines include:

- a. sizing for customers' load,
- b. installation of an excess flow valve (EFV),
- c. locating the service lines, and
- d. future abandonment.

**Sketch 1 – Preferred Split Service Configuration**



For EFV installation requirements and guidance, refer to GS 3020.100 or GS 3020.100(MA) "Service Lines Excess Flow Valves."

## 2.1 Inspection of Materials

All pipe and components must be visually inspected at the job site before installation to ensure they do not have any determinable damage that could impair their serviceability. Refer to GS 3000.020 "Inspection of Materials" for requirements.

Any damaged pipe or components must be appropriately repaired or replaced before installation. Refer to GS 3010.010 "Repair of Steel Pipe" or GS 3010.020 "Repair of Plastic Pipe" for further guidance and requirements.

|                               |                                  |  |
|-------------------------------|----------------------------------|--|
| Effective Date:<br>05/14/2014 | <b>Service Line Installation</b> | Standard Number:<br><b>GS 3020.010</b> |
| Supersedes:<br>10/10/2012     |                                  | Page 3 of 7                            |

## 2.2 Depth

Buried service lines must be installed with at least 18 inches of cover in public streets and road rights-of way, and at least 12 inches of cover on private property. Where practical, it is recommended that at least 18 inches of cover also be maintained on private property.

**EXCEPTION:** In Maryland, service lines are required to be installed with a minimum of 24 inches of cover, unless in solid rock (requiring blasting or pneumatic equipment) where the minimum cover is 18 inches.

Where an underground structure prevents installation at those depths, that portion of the service line may be installed with less cover if it is strengthened or provided with protection to withstand any anticipated external loads. Strengthening the pipe is normally only applicable for steel piping installations. Means to protect the pipe include using casing or providing a rigid material above (bridge) the pipe, such as concrete.

**EXCEPTION:** In Maryland, the service line must be installed with a minimum of 12 inches of cover and provided with additional protection (e.g., casing, concrete pads, or tiling) where normal cover cannot be provided due to an underground structure.

**NOTE:** In Massachusetts, the DPU (state commission) must approve all installations with less than the required cover.

Service risers shall be installed according to the manufacturer's instructions. If an anodeless riser is installed, ensure that the plastic to steel transition point is aboveground. The point is shown on manufacturer-assembled risers by an indication, such as a line and/or label that may read: "Maximum Bury Depth – Do Not Bury" or "Aboveground".

## 2.3 Grading for Drainage

Where condensate in the gas might cause interruption in the gas supply to the customer, the service line must be graded to drain into the main or into drips at the low points in the service line.

## 2.4 Protection against Piping Strain and External Loading

Service lines must be installed to minimize anticipated piping strain and external loading. In order to protect against pipe contraction, especially for plastic, the piping should not be connected at each end so that it is taught. The pipe should be installed generously in the ditch and/or additional length installed at each end.

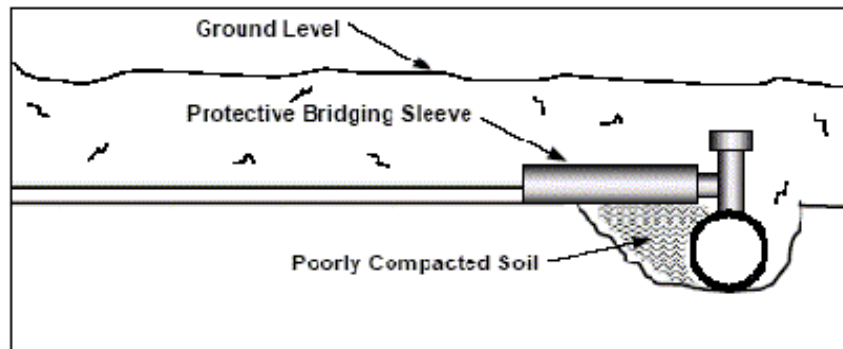
|                               |                                  |  |
|-------------------------------|----------------------------------|--|
| Effective Date:<br>05/14/2014 | <b>Service Line Installation</b> | Standard Number:<br><b>GS 3020.010</b> |
| Supersedes:<br>10/10/2012     |                                  | Page 4 of 7                            |

## 2.5 Support and Backfill

Service lines must be properly supported on undisturbed or well-compacted soil, and material used for backfill must be free of materials that could damage the pipe or its coating.

Care should especially be taken for plastic service line connections at the main. A suitable backfill must be used below the pipe at a service tee, and must be properly compacted to prevent shearing of the pipe. An additional reinforcing sleeve may also be used to “bridge” from the tee to the well-compacted soil, as shown in Figure 1.

**Figure 1 – Plastic Service Line Support at the Service Tee**



As with the service line connection at the main, care should be taken for other transitions to more rigid piping, such as the connection to a service riser or insertion into through-the-wall fittings. Areas around new building foundations are susceptible to settling and if well-compacted soil cannot be assured, then other measures are required to provide support to the rigid piping transition.

## 2.6 Warning Tape

Warning tape shall be installed on all open cut portions of service line installations.

The warning tape should be installed 6" to 12" below the planned final grade. It can be installed during the backfill operation or by plow-in method after the backfill operation is completed.

## 2.7 Installation of Service Lines under Buildings

Where an underground service line is installed under a building:

1. it must be encased in a gas-tight conduit;
2. the conduit and the service line must, if the service line supplies the building it underlies, extend into a normally usable and accessible part of the building; and,



|                               |                                  |  |
|-------------------------------|----------------------------------|--|
| Effective Date:<br>05/14/2014 | <b>Service Line Installation</b> | Standard Number:<br><b>GS 3020.010</b> |
| Supersedes:<br>10/10/2012     |                                  | Page 5 of 7                            |

3. the space between the conduit and the service line must be sealed to prevent gas leakage into the building and, if the conduit is sealed at both ends, a vent line from the annular space must extend to a point where gas would not be a hazard, and extend above grade, terminating in a rain and insect resistant fitting.

## 2.8 Installation of Service Lines into Buildings

Where a service line must enter a building, it is preferred for the entry to be above ground to avoid below ground entry through a foundation wall.

Each underground service line installed below grade through the outer foundation wall of a building shall be encased or sleeved, and must:

1. in the case of a metallic service line, be protected against corrosion;
2. in the case of a plastic service line, be protected from shearing action and backfill settlement; and
3. be sealed at the foundation wall to prevent leakage into the building.

## 3. USE OF TRENCHLESS TECHNOLOGY

If trenchless technology is used to facilitate the installation of service lines, refer to the following gas standards for additional guidance, as applicable.

|             |                         |
|-------------|-------------------------|
| GS 3010.100 | "Trenchless Technology" |
| GS 3010.102 | "Directional Boring"    |
| GS 3010.104 | "Augering with Casing"  |
| GS 3010.106 | "Other Boring Methods"  |

Plastic pipe that is being encased must be inserted into the casing pipe in a manner that will protect the plastic. If a service line is inserted into casing or an existing conduit, the leading end of the carrier pipe (steel or plastic) shall be closed before insertion to prevent dirt from entering it. End caps may be used to accomplish this. Refer to GS 3010.070 or GS 3010.070(MA) "Casing" for additional guidance.

When a service line is permitted to be installed under a railroad or highway and a casing is required, the casing must meet the requirements of GS 3010.070 or GS 3010.070(MA) "Casing" and additional requirements imposed by the permit granting authority.

## 4. PROVIDING FOR LOCATING UNDERGROUND SERVICE LINES

Each underground nonmetallic (i.e., plastic) service line that is not encased in metallic conduit must have a means of locating the pipe, such as the installation of tracer wire.

|                               |                                  |  |
|-------------------------------|----------------------------------|--|
| Effective Date:<br>05/14/2014 | <b>Service Line Installation</b> | Standard Number:<br><b>GS 3020.010</b> |
| Supersedes:<br>10/10/2012     |                                  | Page 6 of 7                            |

Refer to GS 3010.060 "Installation of Plastic Pipe" for acceptable means.

**NOTE:** Tracer wire may not be wrapped around plastic pipe, and contact with the pipe must be minimized but is not prohibited. Tracer wire or other metallic elements installed for pipe locating purposes must be resistant to corrosion damage, either by use of coated copper wire or by other means. The free ends of tracer wire shall be coated or insulated. Refer to GS 3010.060 "Installation of Plastic Pipe" for additional guidance.

Where plastic service lines are encased in metallic conduit, one of the two following methods shall be used to provide a means for locating the plastic pipeline.

- a. Insert tracer wire with the plastic pipe into the metallic conduit if there is ample space within the conduit to avoid damage to the tracer wire or its protective coating. If the service line is connected to a plastic main, then the service line tracer wire shall be connected to the main tracer wire. If the service line is connected to a metallic main, then the service line tracer wire shall not be connected to the metallic pipeline.
- b. Insert plastic pipe without the tracer wire into the metallic conduit. Locations where the remaining conduit has been separated shall be bonded across the cut sections to maintain continuity for locating purposes. In no case shall the bond wire be attached to, or allowed to come in contact with, in-service metallic piping or nonmetallic piping's tracer wire. A preferred option to maintain continuity for locating purposes is to cad-weld the bond wire across the cut-out sections of the casing, as long as the cad-welds are completed prior to the insertion of the plastic pipe to avoid heat damage. If the plastic pipe has already been inserted into the casing, then the bond wire should be connected to the casing by a mechanical wire clamp.

Electronic markers should be installed with the service line at locations where it is anticipated that the piping could be difficult to locate. Refer to GS 3010.050 or GS 3010.050(MA) "Installation of Pipe in a Ditch" for electronic marker installation.

Upon completion of the new or replacement service line installation, the entire service line installation shall be located with appropriate markings and stakes/flags by the Company or Company's contracted personnel according to the applicable GS 1100.010 "Locating Gas Facilities." If tracer or bond wire discontinuities are detected, the location shall be excavated and the problem remediated.

## 5. RECORDS

### 5.1 Company Forms/Database

All applicable Company databases and hardcopy records for service lines shall be updated. The minimum information must indicate the service line:



**Distribution Operations**

**Gas Standard**

|                               |                                  |  |
|-------------------------------|----------------------------------|--|
| Effective Date:<br>05/14/2014 | <b>Service Line Installation</b> | Standard Number:<br><b>GS 3020.010</b> |
| Supersedes:<br>10/10/2012     |                                  | Page 7 of 7                            |

1. material type and size,
2. presence and location of the curb valve, if applicable,
3. presence of the excess flow valve, if applicable, and
4. system pressure.

**5.2 Records Retention**

Required service line information shall be retained for the life of the service line.



**Distribution Operations**

**Gas Standard**

|                               |                                  |  |
|-------------------------------|----------------------------------|--|
| Effective Date:<br>06/01/2016 | <b>Service Line Record (SLR)</b> | Standard Number:<br><b>GS 3020.012</b> |
| Supersedes:<br>N/A            |                                  | Page 1 of 27                           |

Companies Affected:

|                                 |   |   |
|---------------------------------|---|---|
| <input type="checkbox"/> NIPSCO | <input checked="" type="checkbox"/> CGV | <input checked="" type="checkbox"/> CMD |
|                                 | <input checked="" type="checkbox"/> CKY | <input checked="" type="checkbox"/> COH |
|                                 | <input checked="" type="checkbox"/> CMA | <input checked="" type="checkbox"/> CPA |

**REFERENCE** 49 CFR 192.605(b)(3)

**1. GENERAL**

Upon the completion of any O&M Job Order on a Company service line where a DPI was cleared or where excavation was required to perform the work, Form GS 3020.012-1, "Service Line Record", shall be completed. Exceptions are DPIs cleared with Cleared By Codes 00 (Mistake), 33 (Negative Readings), and 34 (Reclassified), which do not require a SLR to be completed.

Upon the completion of any Capital Job Order on a Company service line, Form GS 3020.012-1, "Service Line Record", shall be completed.

Service Line Records (SLR) shall be submitted to and stored within the Company's "Opentext" system. Opentext is the system of record for SLRs.

The SLR replaces the former Service Line Order (SLO), Form C 2641, "Service Line Order."

**1.1 Mapped Service Lines**

Operations Centers that map all service lines in the Company's GIS system are not required to complete SLRs and are not required to upload SLRs to Opentext. The only Operations Center meeting this criteria is Brockton, MA (CMA).

**1.2 Buried Regulators**

For buried high-pressure service regulator installation(s), refer to GS 6400.440, "Buried Service Regulators".

**1.3 Electronic SLR for Construction Services**

Where permitted by Leadership and where Construction Services front line workers (FLW) have been trained and equipped to use it, a Microsoft Excel-based version of the form, Form GS 3020.012-1 (Electronic) "Service Line Record", may be used. The output of the electronic form shall closely match the format and exactly match the content of the paper form, Form GS 3020.012-1, "Service Line Record".

Users of the electronic form shall use only the version of the form approved by Gas Standards. This is the version stored on the Gas Standards' MySource page. Users shall download a copy of the form to their laptops/MDTs when notified by Gas

*This document is considered CONTROLLED only when viewed electronically on the Company's intranet. Printed or other electronic copies may not be current, and the intranet version should be used to verify.*



**Distribution Operations**

**Gas Standard**

|                               |                                  |  |
|-------------------------------|----------------------------------|--|
| Effective Date:<br>06/01/2016 | <b>Service Line Record (SLR)</b> | Standard Number:<br><b>GS 3020.012</b> |
| Supersedes:<br>N/A            |                                  | Page 2 of 27                           |

Standards of an updated version of the form.

Local variations in the electronic form are not permitted.

Any requested changes to Form GS 3020.012-1 (Electronic) shall be requested through Gas Standards' request process. Refer to Form GS 1014.010-1, "Request for New or Revised Gas Standard". If approved to proceed, Gas Standards will engage Construction Services to make the changes to the Excel spreadsheet.

Requirements for the paper form, Form GS 3020.012-1, "Service Line Record," in this standard apply to the electronic form also. An exception is that a physical signature is not required in the "By (Signature; then Print Name & Employee Num & Comp Name)" field. Users of the electronic form shall type Name & Employee Number & Company Name in this field.

**2. COMPLETING THE SLR**

Form GS 3020.012-1, "Service Line Record," shall be completed to record any one of five different functions.

- a. SURVEY.
- b. REPAIR.
- c. NEW.
- d. REPLACE.
- e. ABANDON.

The function is indicated on the SLR by checking the appropriate block. In no case shall more than one block be checked. General instructions for completing the SLR for each function are provided below, followed by specific instructions for completing each field on the form.

**2.1 SURVEY**

The "SURVEY (S)" block is checked whenever information is to be added, or corrected in Company systems (DIS, CIS, WMS, etc.) and where no physical change to an existing service line is involved.

For example, "SURVEY (S)" would be checked when adding or correcting a curb box location. Similarly, the "SURVEY (S)" is checked when initially enter data for existing service lines.

The following fields are always required when submitting a SLR for SURVEY purposes.

- a. Service Address.
- b. PSID/Site ID.



**Distribution Operations**

**Gas Standard**

|                               |                                  |  |
|-------------------------------|----------------------------------|--|
| Effective Date:<br>06/01/2016 | <b>Service Line Record (SLR)</b> | Standard Number:<br><b>GS 3020.012</b> |
| Supersedes:<br>N/A            |                                  | Page 3 of 27                           |

- c. Taxing District.
- d. By (Signature; then Print Name & Employee Num & Comp Name).

Any other field required to describe the information being added or changed in Company systems shall also be completed, including the sketch.

**2.2 REPAIR**

The “REPAIR (F)” block is checked whenever the Company service line is repaired or reconnected.

The following fields are always required when submitting a SLR for REPAIR purposes.

- a. Service Address.
- b. PSID/Site ID.
- c. Taxing District.
- d. Repair Date.
- e. Repair Kind.
- f. By (Signature; then Print Name & Employee Num & Comp Name).

Any other field required to describe the information being added or changed in Company systems shall also be completed, including the sketch.

If the repair involved the installation of any material, the installed material shall be documented in the Material table. All columns (SSN [Stock Symbol Number], Description, Size, Quantity Installed) shall be completed.

**2.3 NEW**

The “NEW (N)” block is checked whenever a new Company service line is installed.

The following fields are always required when submitting a SLR for NEW purposes.

- a. Service Address.
- b. City.
- c. PSID/Site ID.
- d. Location Number.



**Distribution Operations**

**Gas Standard**

|                               |                                  |  |
|-------------------------------|----------------------------------|--|
| Effective Date:<br>06/01/2016 | <b>Service Line Record (SLR)</b> | Standard Number:<br><b>GS 3020.012</b> |
| Supersedes:<br>N/A            |                                  | Page 4 of 27                           |

- e. Taxing District.
- f. Main Number.
- g. Tap Location.
- h. Method of Installation.
- i. By (Signature; then Print Name & Employee Num & Comp Name).

Any other field required to describe the information being added in Company systems shall also be completed, including the sketch.

The installed material shall be documented in the Material table. All columns (SSN, Description, Size, Qty Inst) shall be completed.

**2.4 REPLACE**

The “REPLACE (R)” block is checked whenever there is a replacement of a Company service line and/or a customer-owned service line by the Company.

The following fields are always required when submitting a SLR for REPLACE purposes.

- a. Service Address.
- b. City.
- c. PSID/Site ID.
- d. Location Number.
- e. Taxing District.
- f. By (Signature; then Print Name & Employee Num & Comp Name).

Any other field required to describe the information being added in Company systems shall also be completed, including the sketch.

The installed material shall be documented in the Material table. All columns (SSN, Description, Size, Qty Inst) shall be completed.

**2.5 ABANDON**

The “ABANDON (A)” block is checked whenever a Company service line is abandoned without replacement.

The following fields are always required when submitting a SLR for ABANDON



**Distribution Operations**

**Gas Standard**

|                               |                                  |  |
|-------------------------------|----------------------------------|--|
| Effective Date:<br>06/01/2016 | <b>Service Line Record (SLR)</b> | Standard Number:<br><b>GS 3020.012</b> |
| Supersedes:<br>N/A            |                                  | Page 5 of 27                           |

purposes.

- a. Service Address.
- b. City.
- c. PSID/Site ID.
- d. Location Number.
- e. Taxing District.
- f. By (Signature; then Print Name & Employee Num & Comp Name).
- g. **CMA Only**: Complete Retired Pipe data fields.

**3. REVIEW PRIOR TO STORING IN OPENTEXT**

**3.1 Construction Services**

SLRs shall be reviewed by a Construction Specialist or Construction Leader (or designee) prior to submitting SLRs to the Operations Center for uploading into Opentext.

If the review is of a paper form, the Construction Specialist or Construction Leader (or designee) shall sign the SLR in the "Reviewed By" field.

If the review is of the electronic form, no signature is required. The employee who reviewed the SLR shall type his/her name in the "Reviewed By" field prior to saving the SLR as a PDF or prior to printing the SLR.

SLRs shall be sent to the Operations Center for uploading into Opentext and shall be in printed or PDF format.

**3.2 Field Operations**

SLRs shall be reviewed by a Front Line Leader (FOL) prior to submission for uploading into Opentext. With the permission of the Operation Center Manager, the FOL may name a designee to review the SLRs. The employee who reviewed the SLR shall sign the SLR in the "Reviewed By" field.

**4. UPLOADING THE SLR INTO OPENTEXT**

The designated Operations Center personnel shall upload the SLR to Opentext.





**Distribution Operations**

**Gas Standard**

|                               |                                  |  |
|-------------------------------|----------------------------------|--|
| Effective Date:<br>06/01/2016 | <b>Service Line Record (SLR)</b> | Standard Number:<br><b>GS 3020.012</b> |
| Supersedes:<br>N/A            |                                  | Page 6 of 27                           |

**5. SLR DATA FIELDS**

Refer to Exhibit A of this standard for a key to the data fields on Form GS 3020.012-1, "Service Line Record," and specific instructions for each field.

Refer to Exhibit D of this standard for examples of completed SLRs.

**6. RECORDS**

SLRs shall be retained in accordance with the Company's records retention policy.



**Gas Standard**

|                               |   |  |
|-------------------------------|---|--|
| Effective Date:<br>06/01/2016 | <h2 style="margin: 0;">Service Line Record (SLR)</h2> | Standard Number:<br><b>GS 3020.012</b> |
| Supersedes:<br>N/A            |   | Page 7 of 27                           |

**EXHIBIT A  
(1 OF 12)**

Form GS 3020.012-1 (01/2016) FORM WILL BE SCANNED - PRINT USING BLACK INK

**SERVICE LINE RECORD (SLR)**

JOB ORDER # 1 FORM COMPLETED BY: 2

NEW (N)  REPLACE (R)  ABANDON (A)  REPAIR (F)  SURVEY (S)

|   |  |  |  |  |  |  |  |  |   |
|---|--|--|--|--|--|--|--|--|---|
| SERVICE ADDRESS <span style="border: 1px solid black; border-radius: 50%; padding: 2px;">4</span>   |  |  |  | CITY <span style="border: 1px solid black; border-radius: 50%; padding: 2px;">5</span>           |  |  |  |  |   |
| PSID/SITE ID <span style="border: 1px solid black; border-radius: 50%; padding: 2px;">6</span>  | LOC NUM <span style="border: 1px solid black; border-radius: 50%; padding: 2px;">7</span>  | TAXING DISTRICT <span style="border: 1px solid black; border-radius: 50%; padding: 2px;">8</span>            | MAIN NUM <span style="border: 1px solid black; border-radius: 50%; padding: 2px;">9</span>                 | OP PRESS <span style="border: 1px solid black; border-radius: 50%; padding: 2px;">10</span>      |  |  |  |  |   |
| MAP NUM <span style="border: 1px solid black; border-radius: 50%; padding: 2px;">11</span>  | MAIN SIZE-MATL <span style="border: 1px solid black; border-radius: 50%; padding: 2px;">12</span>                                  | MAIN REFERENCE (LOCATION) <span style="border: 1px solid black; border-radius: 50%; padding: 2px;">13</span> | SPECIAL CONDITION CODES <span style="border: 1px solid black; border-radius: 50%; padding: 2px;">14</span> |  |  |  |  |  |   |
| EFV INSTALLED <input type="checkbox"/> YES <input type="checkbox"/> NO <span style="border: 1px solid black; border-radius: 50%; padding: 2px;">15</span> | EFV MANUF & MODEL <span style="border: 1px solid black; border-radius: 50%; padding: 2px;">16</span>                               |  | GPS COORD <span style="border: 1px solid black; border-radius: 50%; padding: 2px;">17</span>               |  |  |  |  |  |   |
| MAIN TO PROPERTY LINE OR CURB VALVE <span style="border: 1px solid black; border-radius: 50%; padding: 2px;">18</span>                                    | LENGTH <span style="border: 1px solid black; border-radius: 50%; padding: 2px;">A</span>   | SIZE <span style="border: 1px solid black; border-radius: 50%; padding: 2px;">B</span>                       | MATERIAL <span style="border: 1px solid black; border-radius: 50%; padding: 2px;">C</span>                 | DEPTH (IN) <span style="border: 1px solid black; border-radius: 50%; padding: 2px;">D</span>     | OP PRESS <span style="border: 1px solid black; border-radius: 50%; padding: 2px;">E</span>       | DATE INSTL/ABN <span style="border: 1px solid black; border-radius: 50%; padding: 2px;">F</span> | INSTALL MTHD <span style="border: 1px solid black; border-radius: 50%; padding: 2px;">G</span>   | REPAIR DATE <span style="border: 1px solid black; border-radius: 50%; padding: 2px;">H</span>  | REPAIR ENDT <span style="border: 1px solid black; border-radius: 50%; padding: 2px;">I</span> |
|   | PROPERTY LINE OR CURB VALVE TO METER <span style="border: 1px solid black; border-radius: 50%; padding: 2px;">19</span>            | LENGTH <span style="border: 1px solid black; border-radius: 50%; padding: 2px;">A</span>                     | SIZE <span style="border: 1px solid black; border-radius: 50%; padding: 2px;">B</span>                     | MATERIAL <span style="border: 1px solid black; border-radius: 50%; padding: 2px;">C</span>       | DEPTH (IN) <span style="border: 1px solid black; border-radius: 50%; padding: 2px;">D</span>     | OP PRESS <span style="border: 1px solid black; border-radius: 50%; padding: 2px;">E</span>       | DATE INSTL/ABN <span style="border: 1px solid black; border-radius: 50%; padding: 2px;">F</span> | INSTALL MTHD <span style="border: 1px solid black; border-radius: 50%; padding: 2px;">G</span> | REPAIR DATE <span style="border: 1px solid black; border-radius: 50%; padding: 2px;">H</span> |
| RETIRED PIPE <span style="border: 1px solid black; border-radius: 50%; padding: 2px;">20</span>   | LENGTH <span style="border: 1px solid black; border-radius: 50%; padding: 2px;">A</span>   | SIZE <span style="border: 1px solid black; border-radius: 50%; padding: 2px;">B</span>                       | MATERIAL <span style="border: 1px solid black; border-radius: 50%; padding: 2px;">C</span>                 | DEPTH (INCHES) <span style="border: 1px solid black; border-radius: 50%; padding: 2px;">D</span> | DATE INSTALLED <span style="border: 1px solid black; border-radius: 50%; padding: 2px;">E</span> | DATE ABN <span style="border: 1px solid black; border-radius: 50%; padding: 2px;">F</span>       |  |  |   |
| MT <span style="border: 1px solid black; border-radius: 50%; padding: 2px;">21</span>   | MASTER TAP REFERENCE (ADDR AND/OR PSID/SITE ID) <span style="border: 1px solid black; border-radius: 50%; padding: 2px;">22</span> |  | CURB BOX LOCATION <span style="border: 1px solid black; border-radius: 50%; padding: 2px;">23</span>       | TAP LOCATION <span style="border: 1px solid black; border-radius: 50%; padding: 2px;">24</span>  | RISER CODE <span style="border: 1px solid black; border-radius: 50%; padding: 2px;">25</span>    |  |  |  |   |

PRESSURE TESTED PER GAS STANDARD

SRV LINE M-PL/CV \_\_\_\_\_ MINS @ \_\_\_\_\_ PSIG  Soap Test

SRV LINE PL/CV-MTR 26 \_\_\_\_\_ MINS @ \_\_\_\_\_ PSIG  Soap Test 27

BY (SIGNATURE; THEN PRINT NAME & EMPLOYEE NUM & COMP NAME)

ADDITIONAL INFORMATION 28

29

30 PERSONS MAKING WELDS, FUSIONS, AND MECHANICAL FITTING JOINTS

|   |   |
|---|---|
| EMPL NUM & CO _____ <input type="checkbox"/> W <input type="checkbox"/> EF <input type="checkbox"/> SF <input type="checkbox"/> BF <input type="checkbox"/> M | EMPL NUM & CO _____ <input type="checkbox"/> W <input type="checkbox"/> EF <input type="checkbox"/> SF <input type="checkbox"/> BF <input type="checkbox"/> M |
| EMPL NUM & CO _____ <input type="checkbox"/> W <input type="checkbox"/> EF <input type="checkbox"/> SF <input type="checkbox"/> BF <input type="checkbox"/> M | EMPL NUM & CO _____ <input type="checkbox"/> W <input type="checkbox"/> EF <input type="checkbox"/> SF <input type="checkbox"/> BF <input type="checkbox"/> M |

POST INSTALL LOCATING 31  PAINT  FLAGGED  LOCATED

OFFICE USE ONLY: REVIEWED BY AND DATE 32

SKETCH THE SERVICE LINE IN THE SPACE ABOVE; INDICATE NORTH COMPLETE BOTH SIDES OF FORM



**Gas Standard**

|                               |                           |  |
|-------------------------------|---------------------------|--|
| Effective Date:<br>06/01/2016 | Service Line Record (SLR) | Standard Number:<br><b>GS 3020.012</b> |
| Supersedes:<br>N/A            |                           | Page 8 of 27                           |

**EXHIBIT A  
(2 OF 12)**

Form GS 3020.012-1 (rev 01/16) FORM WILL BE SCANNED - USE BLACK INK

SERVICE LINE RECORD (SLR)  
COMPLETE BOTH SIDES OF FORM

33

| MATERIAL |             |      |          |     |             |      |          |
|----------|-------------|------|----------|-----|-------------|------|----------|
| SSN      | DESCRIPTION | SIZE | QTY INST | SSN | DESCRIPTION | SIZE | QTY INST |
| A        | B           | C    | D        |     |             |      |          |
|          |             |      |          |     |             |      |          |
|          |             |      |          |     |             |      |          |
|          |             |      |          |     |             |      |          |
|          |             |      |          |     |             |      |          |
|          |             |      |          |     |             |      |          |
|          |             |      |          |     |             |      |          |
|          |             |      |          |     |             |      |          |

FOR MORE INFORMATION, CONSULT GS 3020.012

REFERENCE CODES

|  |   |  |
|--|---|--|
| <p><b>OF PRESSURE</b></p> <p>LP LOW PRESSURE<br/>IP INTERMEDIATE PRESSURE<br/>MP MEDIUM PRESSURE<br/>HP HIGH PRESSURE</p> <p><b>MASTER TAP</b></p> <p>LEAVE BLANK IF ONLY 1 CUST ON SL (KY, MD, OH, PA, VA)</p> <p>USE DASH (-) IF ONLY 1 CUST ON SL (MA)</p> <p>* PRIMARY REF BY CB<br/>+ OTHER DOWNSTR. CUST<br/>P SPLIT SERVICE; PRIM SL<br/>S SPLIT SERVICE; SEC SL</p> <p><b>MAIN REFERENCE (LOCATION)</b></p> <p>EXAMPLE: 010 S NCU</p> <p>WHERE:<br/>010 = DISTANCE IN FEET<br/>S = SOUTH OF<br/>NCU = REF OBJECT; NORTH CURB</p> <p>FOR ROOFTOP, ADD "RT"</p> <p><b>DESIGNATING CB &amp; OTHER LOCATIONS</b></p> <p>EXAMPLE: 32 FFB S RRB<br/>32 FT FRONT OF FRONT BLDG EDGE<br/>S FEET RIGHT OF RIGHT BLDG EDGE</p> <p><b>RISER CODES</b></p> <p>USE RISER CODE PROVIDED BY VENTYX OR WMS; OR CONTAINED IN DIS CONTROL TABLES</p> <p><b>INSTALLATION METHOD</b></p> <p>OC OPEN CUT<br/>TO TIE OVER<br/>PI PLASTIC INSERT<br/>TT TRENCHLESS TECH</p> | <p><b>OBJECT CODES</b></p> <p>B BLDG EDGE<br/>BK BACK<br/>C CORNER<br/>CEL CENTER OF EB LANE<br/>CLP CENTER OF PAVEMENT<br/>CLR CENTER OF FIT OF WAY<br/>CNL CENTER OF NB LANE<br/>COP CENTER OF PROPERTY<br/>CSL CENTER OF SB LANE<br/>CU CURB<br/>CWL CENTER OF WB LANE<br/>D DRIVEWAY EDGE<br/>EP EDGE OF PAVEMENT<br/>ES EDGE OF SIDEWALK<br/>F FRONT<br/>G GARAGE EDGE<br/>L LEFT<br/>M METER<br/>P PORCH EDGE<br/>PAD TRAILER PAD<br/>PL PROPERTY LINE<br/>R RIGHT<br/>W WATER VALVE</p> <p><b>MATERIAL CODES</b></p> <p>CI CAST IRON<br/>CU COPPER<br/>OT OTHER<br/>P PLASTIC<br/>PI PLASTIC INSERT<br/>S STEEL<br/>ST STEEL, TREATED<br/>WI WROUGHT IRON</p> <p><b>DATE FORMAT</b></p> <p>ALL DATES TO BE IN MM-DD-YYYY FORMAT</p> <p>EXAMPLE: 01-31-2007<br/>EXAMPLE: 11-12-2019</p> <p><b>JOINT TYPES</b></p> <p>BF BUTT FUSION<br/>EF ELECTROFUSION<br/>SF SOCKET FUSION<br/>M MECHANICAL FITTING<br/>W WELDED (STEEL)</p> | <p><b>EPV MANUF &amp; MODEL</b></p> <p>UMAC 300<br/>UMAC 400<br/>UMAC 700<br/>UMAC 1300<br/>UMAC 1800<br/>UMAC 2600<br/>UMAC 3500<br/>UMAC 10,000</p> <p>IF NOT ON LIST, WRITE IN MANUF &amp; MODEL USED</p> <p><b>SPECIAL CONDITIONS</b></p> <p>A ANODE INSTALLED<br/>B BURIED REGULATOR<br/>C CUST ANODE; CO INSTALL<br/>E ELECTRONIC MARKER<br/>F COMPR FITTING ON TIES<br/>G GAS FLOW LIMITER/EPV<br/>H TAP BLW HARD SURFACE<br/>I INSULATOR INSTALLED<br/>J FIT INSTALLED<br/>K EPV TAGGED<br/>L LOC WIRE TIED TO PLASTIC MAIN WIRE<br/>M MULT SRV, 1 SL 1 MTR<br/>N MTR BARRIER INSTALLED<br/>P PLASTIC VALVE<br/>Q FARM TAP<br/>S TEST STATION<br/>T TAP TIE IS MESH PLASTIC<br/>V VLV BRASS MUELLER<br/>W INSTA-TITE METER MOVED OUT<br/>* SEE ADDL INFORMATION</p> <p><b>SIZE CODES (LARGER SIZES SIMILAR)</b></p> <p>005 1/2"<br/>007 3/4"<br/>010 1"<br/>012 1-1/8"<br/>015 1-1/2"<br/>020 2"<br/>030 3"<br/>040 4"</p> |
|--|---|--|



**Distribution Operations**

**Gas Standard**

|                               |                                  |  |
|-------------------------------|----------------------------------|--|
| Effective Date:<br>06/01/2016 | <b>Service Line Record (SLR)</b> | Standard Number:<br><b>GS 3020.012</b> |
| Supersedes:<br>N/A            |                                  | Page 9 of 27                           |

**EXHIBIT A  
 (3 OF 12)**

| Key | Item              | Description   |
|-----|-------------------|---|
| 1   | Job Order         | Enter the WMS job order number  |
| 2   | Form Completed By | Enter the name of the individual completing the form.   |
| 3   | Function          | Check box used to indicate the function involved: New, Replace, Abandon, Repair, or Survey. Check one box only.   |
| 4   | Service Address   | Enter the actual address of the structure for which the service line has been installed.<br><br>The Service Address can be verified by reference to the WMS Job Order or the DIS Inquiry screens.         |
| 5   | City              | Enter the three character City Abbreviation code obtainable from the on-line DIS City Name Abbreviation Table (Table 17).<br><br>Note: City abbreviation shall be related to the Zip Code city reference. |
| 6   | PSID/Site ID      | For KY, MD, OH, PA, VA: Enter the PSID number, which can be obtained from the WMS Job Order or the DIS Inquiry Screens.<br><br>For MA: Enter the CIS Site ID.   |
| 7   | Location Number   | Enter the 4-digit location number (TCC) applicable to the Operations Center and the location of the service line.   |
| 8   | Taxing District   | Enter the Taxing District Number.<br><br>Note: The Taxing District is where the gas is actually consumed.   |



**Distribution Operations**

**Gas Standard**

|                               |                                  |  |
|-------------------------------|----------------------------------|--|
| Effective Date:<br>06/01/2016 | <b>Service Line Record (SLR)</b> | Standard Number:<br><b>GS 3020.012</b> |
| Supersedes:<br>N/A            |                                  | Page 10 of 27                          |

**EXHIBIT A  
 (4 OF 12)**

| Key | Item                      | Description  |
|-----|---------------------------|--|
| 9   | Main Number               | Enter the Main Number.   |
| 10  | Operating Pressure        | Enter the operating pressure designation: LP, IP, MP, or HP.   |
| 11  | Map Number                | Enter the Operating Map Number.  |
| 12  | Main Size-Material        | Enter the applicable Main Size and Material codes, using the reference codes on the back side of the SLR.  |
| 13  | Main Reference (Location) | Enter codes for main location using the reference codes on the back side of the SLR.<br><br>If the main location is a rooftop, indicate "RT" followed by the riser valve location. The riser valve location is coded similar to a curb box location.   |
| 14  | Special Condition Codes   | Indicate any/all special features that apply to the service line (i.e., anode installed, buried regulator, etc.) using the reference codes on the back side of the SLR.<br><br>Include separate codes for each EFV installed, i.e. a service line with 2 EFVs would include "GG".<br><br><u>For CKY only</u> , Code H is used to indicate "Main/tap under hard surface." |
| 15  | EFV Installed             | Check box used to indicate if at least one EFV is installed. Check one box only.   |
| 16  | EFV Manufacturer & Model  | Enter the manufacturer and model of the EFV(s) installed, i.e. UMAC 700. If more than one EFV is installed, list all EFVs installed on the service line.   |



**Distribution Operations**

**Gas Standard**

|                               |                                  |  |
|-------------------------------|----------------------------------|--|
| Effective Date:<br>06/01/2016 | <b>Service Line Record (SLR)</b> | Standard Number:<br><b>GS 3020.012</b> |
| Supersedes:<br>N/A            |                                  | Page 11 of 27                          |

**EXHIBIT A  
(5 OF 12)**

| Key | Item                                 | Description   |
|-----|--------------------------------------|---|
| 17  | GPS Coordinates<br>(of tap location) | <p>Enter the GPS coordinates for the location of the tap. If a high accuracy GPS device (sub-decimeter) is available, use this device to obtain the coordinates. Otherwise, use the identify function of ArcReader, a smartphone, or other GPS device to obtain the coordinates.</p> <p>If the coordinates come from a high accuracy (sub-decimeter) GPS device, mark "HA" after the coordinates.</p> <p>Example shown in the same format as used by Ventyx (MDT): -82.924542 40.127884</p> |
| 18  | Main to Property or Curb Valve       | Fields related to the SERV1 ("Company") segment of the service line. For CPA locations with Customer owned service lines, this is the Company-owned segment of the service line.  |
| 18A | Length                               | Enter the shortest distance, in feet, from the main to the property line or curb valve as measured in a straight line. DO NOT measure offsets. If service line has an offset, place an asterisk (*) directly in front of service length, (e.g. *25) and show length of offset in the sketch.  |
| 18B | Size                                 | Enter the code for the size of this segment of the service line, using the reference codes on the back side of the SLR.   |
| 18C | Material                             | Enter the code for the material of this segment of the service line, using the reference codes on the back side of the SLR.   |
| 18D | Depth                                | Enter the depth of cover, in inches, for this segment of the service line.  |
| 18E | Operating Pressure                   | Enter the operating pressure, with units of measure, for this segment of the service line (e.g. 7"wc, 2#)   |



**Distribution Operations**

**Gas Standard**

|                               |                                  |  |
|-------------------------------|----------------------------------|--|
| Effective Date:<br>06/01/2016 | <b>Service Line Record (SLR)</b> | Standard Number:<br><b>GS 3020.012</b> |
| Supersedes:<br>N/A            |                                  | Page 12 of 27                          |

**EXHIBIT A  
 (6 OF 12)**

| Key | Item                                 | Description  |
|-----|--------------------------------------|--|
| 18F | Date Installed or Abandoned          | Enter the date that this segment of the service line was installed or abandoned (e.g. 5/1/1995). This date does not change when a service line is repaired or surveyed.  |
| 18G | Install Method                       | Enter the code for the installation method, using the reference codes on the back side of the SLR.   |
| 18H | Repair Date                          | Enter the date that this segment of the service line was repaired (e.g. 5/1/1995).   |
| 18i | Repair Kind                          | Enter the kind of repair on this segment of the service line. Examples:<br>VALVE = curb valve changed<br>TEE = replaced or repaired tee<br>REC = plastic reconnect was made<br>CUBOX = curb box<br>FACDAM = facility damage<br>LEAK = leak repair<br>REINSP = negative reinspection  |
| 19  | Property Line or Curb Valve to Meter | Fields related to the SERV2 ("Customer") segment of the service line. For CPA locations with Customer owned service lines, this is the Customer-owned segment of the service line.   |
| 19A | Length                               | Enter the shortest distance, in feet, from the property line or curb valve to the meter as measured in a straight line. DO NOT measure offsets. If service line has an offset, place an asterisk (*) directly in front of service length, (e.g. *25) and show length of offset in the sketch.<br><br>For rooftop service lines, enter the length of service line from the outlet of the punch to riser ell. If less than a foot, indicate "1". |



**Distribution Operations**

**Gas Standard**

|                               |                                  |  |
|-------------------------------|----------------------------------|--|
| Effective Date:<br>06/01/2016 | <b>Service Line Record (SLR)</b> | Standard Number:<br><b>GS 3020.012</b> |
| Supersedes:<br>N/A            |                                  | Page 13 of 27                          |

**EXHIBIT A  
(7 OF 12)**

| Key | Item                        | Description   |
|-----|-----------------------------|---|
| 19B | Size                        | Enter the code for the size of this segment of the service line, using the reference codes on the back side of the SLR.   |
| 19C | Material                    | Enter the code for the material of this segment of the service line, using the reference codes on the back side of the SLR.   |
| 19D | Depth                       | Enter the depth of cover, in inches, for this segment of the service line.  |
| 19E | Operating Pressure          | Enter the operating pressure, with units of measure, for this segment of the service line (e.g. 7"wc, 2#)   |
| 19F | Date Installed or Abandoned | Enter the date that this segment of the service line was installed or abandoned (e.g. 5/1/1995). This date does not change when a service line is repaired of surveyed.   |
| 19G | Install Method              | Enter the code for the installation method, using the reference codes on the back side of the SLR.  |
| 19H | Repair Date                 | Enter the date that this segment of the service line was repaired (e.g. 5/1/1995).  |
| 19i | Repair Kind                 | Enter the kind of repair on this segment of the service line. Examples:<br>VALVE = curb valve changed<br>TEE = replaced or repaired tee<br>REC = plastic reconnect was made<br>CUBOX = curb box<br>FACDAM = facility damage<br>LEAK = leak repair<br>REINSP = negative reinspection |





**Distribution Operations**

**Gas Standard**

|                               |                                  |  |
|-------------------------------|----------------------------------|--|
| Effective Date:<br>06/01/2016 | <b>Service Line Record (SLR)</b> | Standard Number:<br><b>GS 3020.012</b> |
| Supersedes:<br>N/A            |                                  | Page 14 of 27                          |

**EXHIBIT A  
(8 OF 12)**

| Key | Item                 | Description  |
|-----|----------------------|--|
| 20  | Retired Pipe         | <u>CMA Only</u> : Fields related to retired pipe   |
| 20A | Length               | <u>CMA Only</u> : Enter the total length, in feet, of pipe retired as part of the work.  |
| 20B | Size                 | <u>CMA Only</u> : Enter the code for the size of this segment of the service line, using the reference codes on the back side of the SLR.  |
| 20C | Material             | <u>CMA Only</u> : Enter the code for the material of this segment of the service line, using the reference codes on the back side of the SLR.  |
| 20D | Depth                | <u>CMA Only</u> : Enter the depth of cover, in inches, for this segment of the service line.   |
| 20E | Date Installed       | <u>CMA Only</u> : Enter the date that the retired pipe was installed (e.g. 5/1/1995).  |
| 20F | Date Abandoned       | <u>CMA Only</u> : Enter the date that the retired pipe was abandoned (e.g. 5/1/1995).  |
| 21  | Master Tap (MT)      | Enter the master tap code for the service line, using the reference codes on the back side of the SLR.<br><br><u>CKY, CMD, COH, CPA, CGV</u> : If the tap serves only one customer or this SLR is for the primary customer, leave blank.<br><br><u>CMA Only</u> : If the tap serves only one customer or this SLR is for the primary customer, enter a dash (-). |
| 22  | Master Tap Reference | Leave blank if the service line serves only one customer or if the SLR is for the primary customer. Enter the PSID (preferred for KY, MD, OH, PA, VA) or CIS Site ID (preferred for MA) or the address of the master tap, if the service line is not the only customer on the service line and the SLR is not for the primary customer.                          |



**Distribution Operations**

**Gas Standard**

|                               |                                  |  |
|-------------------------------|----------------------------------|--|
| Effective Date:<br>06/01/2016 | <b>Service Line Record (SLR)</b> | Standard Number:<br><b>GS 3020.012</b> |
| Supersedes:<br>N/A            |                                  | Page 15 of 27                          |

**EXHIBIT A  
 (9 OF 12)**

| Key | Item              | Description  |
|-----|-------------------|--|
| 23  | Curb Box Location | <p>For one customer downstream of one curb valve, enter codes for Curb Box Location using reference codes on back side of the SLR. The straight line method shall be used to depict curb box locations.</p> <p>Locations that cannot be abbreviated shall be noted by "See Sketch" being placed in block and the sketch shall depict the location in the best manner possible.</p> <p>The default for the front of the customer building shall be the side of the customer building facing the street listed as the street address in company systems. If the front of the building needs to be indicated as a different side of the building than the default, the side of the building being used as the front of the building shall be clearly indicated in the sketch as "F".</p> <p>For service lines installed with no curb valve or excess flow valve, enter "NCV."</p> <p>For service lines installed with one or more excess flow valves, enter "EFV-NCV."</p> <p>If more than one customer is downstream from one curb valve, enter codes for Curb Box Location for the customer designated as the primary customer using reference codes on the back side of the SLR. On the SLR(s) for the other customers enter the PSID/CIS Site ID of primary customer.</p> |



**Distribution Operations**

**Gas Standard**

|                               |                                  |  |
|-------------------------------|----------------------------------|--|
| Effective Date:<br>06/01/2016 | <b>Service Line Record (SLR)</b> | Standard Number:<br><b>GS 3020.012</b> |
| Supersedes:<br>N/A            |                                  | Page 16 of 27                          |

**EXHIBIT A  
 (10 OF 12)**

| Key | Item            | Description  |
|-----|-----------------|--|
| 24  | Tap Location    | <p>For one customer downstream of the tap, enter codes for Tap Location using reference codes on back side of the SLR. The straight line method shall be used to depict curb box locations.</p> <p>Locations that cannot be abbreviated shall be noted by "See Sketch" being placed in block and the sketch shall depict the location in the best manner possible.</p> <p>The default for the front of the customer building shall be the side of the customer building facing the street listed as the street address in company systems. If the front of the building needs to be indicated as a different side of the building than the default, the side of the building being used as the front of the building shall be clearly indicated in the sketch as "F".</p> <p>If the SLR is for the primary customer of a master tap, enter the Tap Location using reference codes on the back side of the SLR. On the SLR(s) for the other customers (not primary) enter the PSID/CIS Site ID of primary customer.</p> |
| 25  | Riser Code      | Enter the riser code provided by Ventyx (MDT) or contained in the DIS control tables.  |
| 26  | Pressure Tested | Enter the pressure test information for one or both segments of the service line, as applicable to the work being performed.   |



**Distribution Operations**

**Gas Standard**

|                               |                                  |  |
|-------------------------------|----------------------------------|--|
| Effective Date:<br>06/01/2016 | <b>Service Line Record (SLR)</b> | Standard Number:<br><b>GS 3020.012</b> |
| Supersedes:<br>N/A            |                                  | Page 17 of 27                          |

**EXHIBIT A  
 (11 OF 12)**

| Key | Item                   | Description   |
|-----|------------------------|---|
| 27  | By                     | <p>For SLRs filled out using the paper form, Form GS 3020.012-1, "Service Line Record," the individual performing the pressure tests shall sign the form and print name, employee number, and company (e.g. Jane Doe, U123456, CPA).</p> <p>For SLRs filled out using the electronic SLR, Form GS 3020.012-1 (Electronic), "Service Line Record," the individual performing the pressure tests shall type name, employee number, and company (e.g. Jane Doe, U123456, CPA). No signature is required.</p>   |
| 28  | Additional Information | Any additional information about the tap and/or the service line may be entered.  |
| 29  | Sketch                 | <p>Illustrate, at minimum, the customer building(s), street(s), location of tap, service line segments, location of curb box. Indicate distances (in feet), offsets involved, and/or unusual configurations.</p> <p>Sketches shall be clear and accurate simple line drawings in "plan" view (as seen from above, looking down on the location). It is preferred that sketches be oriented as if the person viewing the sketch on the SLR is facing the default front of the customer building. Sketches shall not be assumed to be to scale.</p> <p>The default for the front of the customer building shall be the side of the customer building facing the street listed as the street address in company systems. If the front of the building needs to be indicated as a different side of the building than the default, the side of the building being used as the front of the building shall be clearly indicated in the sketch as "F".</p> <p>Any other information required by the Operations Center, i.e. swing ties, shall be indicated.</p> <p>Indicate the direction of north with an arrow and "N".</p> |



**Distribution Operations**

**Gas Standard**

|                               |                                  |  |
|-------------------------------|----------------------------------|--|
| Effective Date:<br>06/01/2016 | <b>Service Line Record (SLR)</b> | Standard Number:<br><b>GS 3020.012</b> |
| Supersedes:<br>N/A            |                                  | Page 18 of 27                          |

**EXHIBIT A  
 (12 OF 12)**

| Key | Item   | Description   |
|-----|--|---|
| 30  | Persons Making Welds, Fusions, and Mechanical Fitting Joints | Fields related to documenting joints for material tracking and traceability purposes.<br><br>For company work, enter the employee number and company and check the box(es) for each type of joint that the individual made.<br><br>Contractors making joint shall enter their unique employee number and a recognizable abbreviation of their company, if their company name does not fit in the space provided. Check the box(es) for each type of joint that the individual made.<br><br>Example (Company): U567890 COH<br>Example (Contractor): 123456 Infrasource<br>Example (Contractor): 123456 NPL |
| 31  | Post Install Locating  | Indicate the type of post-installation locating used.   |
| 32  | Office Use Only: Reviewed By and Date                        | If the Operations Center has a review process in place prior to submitting SLRs to Opentext, the company employee reviewing the SLR for accuracy shall print or type their name and the date the SLR was reviewed.<br><br>If the Operations Center does not have a review process, leave blank.   |
| 33  | Material   | Fields for documenting materials installed.   |
| 33A | SSN  | Enter the stock symbol number, with dashes, for the material (e.g. 16-03-015 for a 1x1 UMAC 700 EFV).   |
| 33B | Description  | Enter a brief description of the material (e.g. EFV).   |
| 33C | Size   | Enter the size of the material (e.g. 010, 012, or 2x1).   |
| 33D | Quantity Installed   | Enter the number of the items for the applicable stock symbol number. Items measured by length, such as pipe, should be entered in feet used.   |



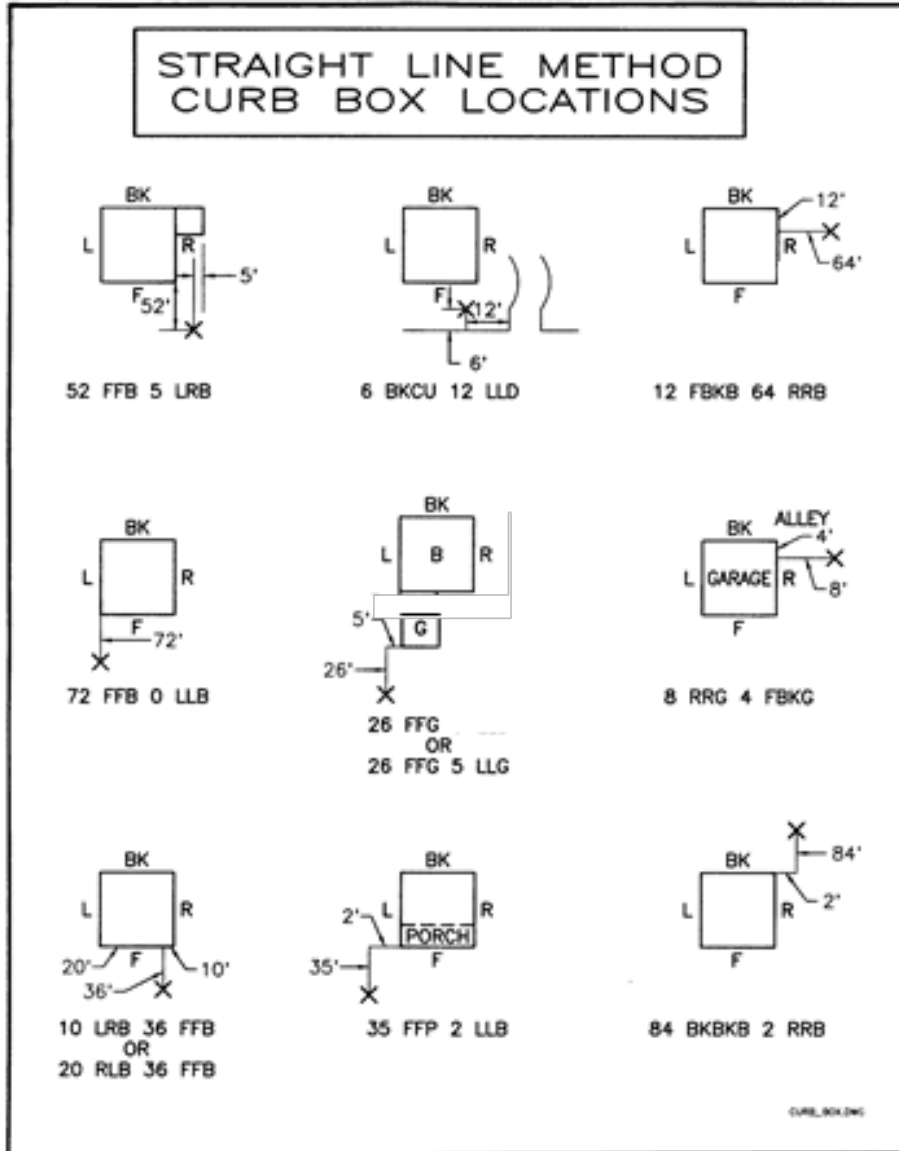
Distribution Operations

Gas Standard

|                               |                                  |  |
|-------------------------------|----------------------------------|--|
| Effective Date:<br>06/01/2016 | <b>Service Line Record (SLR)</b> | Standard Number:<br><b>GS 3020.012</b> |
| Supersedes:<br>N/A            |                                  | Page 19 of 27                          |

**EXHIBIT B  
(1 OF 1)**

Examples of Straight Line Method



Note: Using a driveway as a reference should only be done where there is no line of sight to the building from the curb valve location.



Gas Standard

|                               |                                  |  |
|-------------------------------|----------------------------------|--|
| Effective Date:<br>06/01/2016 | <b>Service Line Record (SLR)</b> | Standard Number:<br><b>GS 3020.012</b> |
| Supersedes:<br>N/A            |                                  | Page 20 of 27                          |

**EXHIBIT C  
(1 OF 6)**

Examples of Non-Straight Line Method (For Documenting Legacy Piping Only)

**Split Service with Company Curb Valves (Primary)**

Form GS 3020.0 PRINTING BLACK INK

JOB ORDER # 01-123456-00 FORM COMPLETED BY: \_\_\_\_\_

NEW (N)  REPLACE (R)  ABANDON (A)  REPAIR (F)  SURVEY (S)

|   |   |                           |  |                                    |   |                             |              |             |            |
|---|---|---------------------------|--|------------------------------------|---|-----------------------------|--------------|-------------|------------|
| SERVICE ADDRESS<br><u>11 Cherry St.</u>   |   |                           |  | CITY<br><u>Anywhere</u>            |   |                             |              |             |            |
| PSID/SITE ID<br><u>300123456</u>  |   | LOC NUM                   | TAXING DISTRICT                        | MAIN NUM                           | OP PRESS  |                             |              |             |            |
| MAP NUM   | MAIN SIZE-MATL                                  | MAIN REFERENCE (LOCATION) |  | SPECIAL CONDITION CODES            |   |                             |              |             |            |
| EFV INSTALLED <input type="checkbox"/> YES <input type="checkbox"/> NO  | EFV MANUF & MODEL                               |                           |  | GPS COORD                          |   |                             |              |             |            |
| MAIN TO PROPERTY LINE OR CURB VALVE   | LENGTH  | SIZE                      | MATERIAL                               | DEPTH (IN)                         | OP PRESS  | DATE INSTL/ABN              | INSTALL METH | REPAIR DATE | REPAIR END |
|   | LENGTH  | SIZE                      | MATERIAL                               | DEPTH (IN)                         | OP PRESS  | DATE INSTL/ABN              | INSTALL METH | REPAIR DATE | REPAIR END |
| PROPERTY LINE OR CURB VALVE TO METER  | LENGTH  | SIZE                      | MATERIAL                               | DEPTH (IN)                         | OP PRESS  | DATE INSTL/ABN              | INSTALL METH | REPAIR DATE | REPAIR END |
| RETIRED PIPE  | LENGTH  | SIZE                      | MATERIAL                               | DEPTH (INCHES)                     | DATE INSTALLED  |                             | DATE ABN     |             |            |
| MT<br><u>T</u>  | MASTER TAP REFERENCE (ADDR AND/OR PSID/SITE ID) |                           | CURB BOX LOCATION<br><u>3RRB 12FFB</u> |                                    | TAP LOCATION  |                             | RISER CODE   |             |            |
| PRESSURE TESTED PER GAS STANDARD  |   |                           |  |                                    | BY (SIGNATURE; THEN PRINT NAME & EMPLOYEE NUM & COMP NAME)  |                             |              |             |            |
| <input type="checkbox"/> SRV LINE M-PL/CV   |   | MINS @                    | PSIG                                   | <input type="checkbox"/> Soap Test |   | <u>J. Doe J. Doe 123456</u> |              |             |            |
| <input type="checkbox"/> SRV LINE PL/CV-MTR   |   | MINS @                    | PSIG                                   | <input type="checkbox"/> Soap Test |   |                             |              |             |            |
| ADDITIONAL INFORMATION  |   |                           |  |                                    |   |                             |              |             |            |
|   |   |                           |  |                                    |   |                             |              |             |            |
| PERSONS MAKING WELDS, FUSIONS, AND MECHANICAL FITTING JOINTS  |   |                           |  |                                    |   |                             |              |             |            |
| EMPL NUM & CO <input type="checkbox"/> W <input type="checkbox"/> EF <input type="checkbox"/> SF <input type="checkbox"/> BF <input type="checkbox"/> M |   |                           |  |                                    | EMPL NUM & CO <input type="checkbox"/> W <input type="checkbox"/> EF <input type="checkbox"/> SF <input type="checkbox"/> BF <input type="checkbox"/> M |                             |              |             |            |
| EMPL NUM & CO <input type="checkbox"/> W <input type="checkbox"/> EF <input type="checkbox"/> SF <input type="checkbox"/> BF <input type="checkbox"/> M |   |                           |  |                                    | EMPL NUM & CO <input type="checkbox"/> W <input type="checkbox"/> EF <input type="checkbox"/> SF <input type="checkbox"/> BF <input type="checkbox"/> M |                             |              |             |            |
| POST INSTALL LOCATING <input type="checkbox"/> PAINT <input type="checkbox"/> FLAGGED <input type="checkbox"/> LOCATED                                  |   |                           |  |                                    | OFFICE USE ONLY: REVIEWED BY AND DATE   |                             |              |             |            |

SKETCH THE SERVICE LINE IN THE SPACE ABOVE; INDICATE NORTH COMPLETE BOTH SIDES OF FORM



Gas Standard

|                               |                                  |  |
|-------------------------------|----------------------------------|--|
| Effective Date:<br>06/01/2016 | <b>Service Line Record (SLR)</b> | Standard Number:<br><b>GS 3020.012</b> |
| Supersedes:<br>N/A            |                                  | Page 21 of 27                          |

**EXHIBIT C  
(2 OF 6)**

Split Service with Company Curb Valves (Secondary)

PRINT IN BLACK INK

Form GS 3020.012

JOB ORDER # 01-123456-00 FORM COMPLETED BY: \_\_\_\_\_

NEW (N)  REPLACE (R)  ABANDON (A)  REPAIR (F)  SURVEY (S)

|  |   |                               |   |                         |                |
|--|---|-------------------------------|---|-------------------------|----------------|
| SERVICE ADDRESS<br><u>13 Cherry St.</u>  |   |                               |   | CITY<br><u>Anywhere</u> |                |
| PSID/SITE ID<br><u>300123457</u>   | LOC NUM   | TAXING DISTRICT<br><u>123</u> | MAIN NUM  | OP PRESS                |                |
| MAP NUM  | MAIN SIZE-MATL  | MAIN REFERENCE (LOCATION)     | SPECIAL CONDITION CODES   |                         |                |
| EFV INSTALLED <input type="checkbox"/> YES <input type="checkbox"/> NO   | EFV MANUF & MODEL   |                               | GPS COORD   |                         |                |
| MAIN TO PROPERTY LINE OR CURB VALVE  | LENGTH  | SIZE                          | MATERIAL  | DEPTH (IN)              | OP PRESS       |
| PROPERTY LINE OR CURB VALVE TO METER   | LENGTH  | SIZE                          | MATERIAL  | DEPTH (IN)              | OP PRESS       |
| RETIRED PIPE   | LENGTH  | SIZE                          | MATERIAL  | DEPTH (INCHES)          | DATE INSTALLED |
| MT<br><u>S</u>   | MASTER TAP REFERENCE (ADDR AND/OR PSID/SITE ID)<br><u>300123456</u> |                               | CURB BOX LOCATION<br><u>5LLB 10FFB</u>  |                         | RISER CODE     |
| PRESSURE TESTED PER GAS STANDARD<br><input type="checkbox"/> SRV LINE M-PL/CV _____ MINS @ _____ PSIG <input type="checkbox"/> Soap Test<br><input type="checkbox"/> SRV LINE PL/CV-MTR _____ MINS @ _____ PSIG <input type="checkbox"/> Soap Test |   |                               | BY (SIGNATURE; THEN PRINT NAME & EMPLOYEE NUM & COMP NAME)<br><u>J. Doe J. Doe 123456</u> |                         |                |
| ADDITIONAL INFORMATION   |   |                               |   |                         |                |

|  |                                |                                  |                                  |                                       |                            |               |                            |                             |                             |                             |                            |
|--|--------------------------------|----------------------------------|----------------------------------|---------------------------------------|----------------------------|---------------|----------------------------|-----------------------------|-----------------------------|-----------------------------|----------------------------|
| PERSONS MAKING WELDS, FUSIONS, AND MECHANICAL FITTING JOINTS |                                |                                  |                                  |                                       |                            |               |                            |                             |                             |                             |                            |
| EMPL NUM & CO  | <input type="checkbox"/> W     | <input type="checkbox"/> EF      | <input type="checkbox"/> SF      | <input type="checkbox"/> BF           | <input type="checkbox"/> M | EMPL NUM & CO | <input type="checkbox"/> W | <input type="checkbox"/> EF | <input type="checkbox"/> SF | <input type="checkbox"/> BF | <input type="checkbox"/> M |
| EMPL NUM & CO  | <input type="checkbox"/> W     | <input type="checkbox"/> EF      | <input type="checkbox"/> SF      | <input type="checkbox"/> BF           | <input type="checkbox"/> M | EMPL NUM & CO | <input type="checkbox"/> W | <input type="checkbox"/> EF | <input type="checkbox"/> SF | <input type="checkbox"/> BF | <input type="checkbox"/> M |
| POST INSTALL LOCATING  | <input type="checkbox"/> PAINT | <input type="checkbox"/> FLAGGED | <input type="checkbox"/> LOCATED | OFFICE USE ONLY: REVIEWED BY AND DATE |                            |               |                            |                             |                             |                             |                            |

SKETCH THE SERVICE LINE IN THE SPACE ABOVE; INDICATE NORTH COMPLETE BOTH SIDES OF FORM





Gas Standard

|                               |                                  |  |
|-------------------------------|----------------------------------|--|
| Effective Date:<br>06/01/2016 | <b>Service Line Record (SLR)</b> | Standard Number:<br><b>GS 3020.012</b> |
| Supersedes:<br>N/A            |                                  | Page 22 of 27                          |

**EXHIBIT C  
(3 OF 6)**

Form GS 3020.012 Split Service with Customer Valves (Primary) PRINT IN BLACK INK

JOB ORDER # 01-123457-00 FORM COMPLETED BY: J. Doe

NEW (N)  REPLACE (R)  ABANDON (A)  REPAIR (F)  SURVEY (S)

|  |   |                           |                                 |                                    |  |                             |              |                 |            |
|--|---|---------------------------|---------------------------------|------------------------------------|--|-----------------------------|--------------|-----------------|------------|
| SERVICE ADDRESS<br><u>29 Main St.</u>                                  |   |                           |                                 | CITY<br><u>Anywhere</u>            |  |                             |              |                 |            |
| PSID/SITE ID<br><u>400123456</u>                                       |   | LOC NUM                   | TAXING DISTRICT<br><u>123</u>   | MAIN NUM                           | OP PRESS   |                             |              |                 |            |
| MAP NUM  | MAIN SIZE-MATL                                  | MAIN REFERENCE (LOCATION) |                                 | SPECIAL CONDITION CODES            |  |                             |              |                 |            |
| EFV INSTALLED <input type="checkbox"/> YES <input type="checkbox"/> NO | EFV MANUF & MODEL                               |                           |                                 | GPS COORD                          |  |                             |              |                 |            |
| MAIN TO PROPERTY LINE OR CURB VALVE                                    | LENGTH  | SIZE                      | MATERIAL                        | DEPTH (IN)                         | OP PRESS   | DATE INSTL (MM/YY)          | INSTALL MTHD | REPAIR DATE     | REPAIR KWD |
|  |   |                           |                                 |                                    |  |                             |              | <u>01-22-01</u> | <u>TEE</u> |
| PROPERTY LINE OR CURB VALVE TO METER                                   | LENGTH  | SIZE                      | MATERIAL                        | DEPTH (IN)                         | OP PRESS   | DATE INSTL (MM/YY)          | INSTALL MTHD | REPAIR DATE     | REPAIR KWD |
| RETIRED PIPE   | LENGTH  | SIZE                      | MATERIAL                        | DEPTH (INCHES)                     |  | DATE INSTALLED              |              | DATE ABN        |            |
| MIT *  | MASTER TAP REFERENCE (ADDR AND/OR PSID/SITE ID) |                           | CURB BOX LOCATION<br><u>NLV</u> |                                    | TAP LOCATION   | RISER CODE                  |              |                 |            |
| PRESSURE TESTED PER GAS STANDARD                                       |   |                           |                                 |                                    | BY (SIGNATURE; THEN PRINT NAME & EMPLOYEE NUM & COMP NAME) |                             |              |                 |            |
| <input type="checkbox"/> SRV LINE M-PL/CV                              |   | MINS @                    | PSIG                            | <input type="checkbox"/> Soap Test |  | <u>J. Doe J. Doe 123456</u> |              |                 |            |
| <input type="checkbox"/> SRV LINE PL/CV-MTR                            |   | MINS @                    | PSIG                            | <input type="checkbox"/> Soap Test |  |                             |              |                 |            |
| ADDITIONAL INFORMATION <u>CUSTOMER VALVE LOCATION 2 RRB 2 FFB</u>      |   |                           |                                 |                                    |  |                             |              |                 |            |

|  |   |                                       |   |
|--|---|---------------------------------------|---|
| PERSONS MAKING WELDS, FUSIONS, AND MECHANICAL FITTING JOINTS |   |                                       |   |
| EMPL NUM & CO  | <input type="checkbox"/> W <input type="checkbox"/> EF <input type="checkbox"/> SF <input type="checkbox"/> BF <input type="checkbox"/> M | EMPL NUM & CO                         | <input type="checkbox"/> W <input type="checkbox"/> EF <input type="checkbox"/> SF <input type="checkbox"/> BF <input type="checkbox"/> M |
| EMPL NUM & CO  | <input type="checkbox"/> W <input type="checkbox"/> EF <input type="checkbox"/> SF <input type="checkbox"/> BF <input type="checkbox"/> M | EMPL NUM & CO                         | <input type="checkbox"/> W <input type="checkbox"/> EF <input type="checkbox"/> SF <input type="checkbox"/> BF <input type="checkbox"/> M |
| POST INSTALL LOCATING  | <input type="checkbox"/> PAINT <input type="checkbox"/> FLAGGED <input type="checkbox"/> LOCATED  | OFFICE USE ONLY: REVIEWED BY AND DATE |   |

SKETCH THE SERVICE LINE IN THE SPACE ABOVE; INDICATE NORTH COMPLETE BOTH SIDES OF FORM



Gas Standard

|                               |                                  |  |
|-------------------------------|----------------------------------|--|
| Effective Date:<br>06/01/2016 | <b>Service Line Record (SLR)</b> | Standard Number:<br><b>GS 3020.012</b> |
| Supersedes:<br>N/A            |                                  | Page 23 of 27                          |

**EXHIBIT C  
(4 OF 6)**

Form GS 3020.01 **Split Service with Customer Valves (Secondary)** PRINT IN BLACK INK

JOB ORDER # 01-123457-00 FORM COMPLETED BY: J. Doe

NEW (N)  REPLACE (R)  ABANDON (A)  REPAIR (F)  SURVEY (S)

|  |   |   |      |   |                |                             |   |
|--|---|---|------|---|----------------|-----------------------------|---|
| SERVICE ADDRESS<br><u>31 Main St.</u>  |   |   |      | CITY<br><u>Anywhere</u>                                     |                |                             |   |
| PSID/SITE ID<br><u>400123457</u>   |   | LOC NUM   |      | TAXING DISTRICT<br><u>123</u>                               |                | MAIN NUM                    |   |
| MAP NUM  |   | MAIN SIZE-MATL  |      | MAIN REFERENCE (LOCATION)                                   |                | SPECIAL CONDITION CODES     |   |
| EFV INSTALLED <input type="checkbox"/> YES <input type="checkbox"/> NO   |   | EFV MANUF & MODEL   |      |   | GPS COORD      |                             |   |
| MAIN TO PROPERTY LINE OR CURB VALVE  |   | LENGTH  | SIZE | MATERIAL  | DEPTH (IN)     | OP PRESS                    | DATE INSTL/ABN  |
| PROPERTY LINE OR CURB VALVE TO METER   |   | LENGTH  | SIZE | MATERIAL  | DEPTH (IN)     | OP PRESS                    | DATE INSTL/ABN  |
| RETIRED PIPE   |   | LENGTH  | SIZE | MATERIAL  | DEPTH (INCHES) | DATE INSTALLED              | DATE ABN  |
| MT<br><u>+</u>   | MASTER TAP REFERENCE (ADDR AND/OR PSID/SITE ID)<br><u>400123456</u> |   |      | CURB BOX LOCATION<br><u>NCV</u>                             |                | TAP LOCATION                |   |
| PRESSURE TESTED PER GAS STANDARD   |   |   |      | BY (SIGNATURE); THEN PRINT NAME & EMPLOYEE NUM & COMP NAME) |                |                             |   |
| <input type="checkbox"/> SRV LINE M-PL/CV  |   | MINS @ _____ PSIG   |      | <input type="checkbox"/> Soap Test                          |                | <u>J. Doe J. Doe 123456</u> |   |
| <input type="checkbox"/> SRV LINE PL/CV-MTR  |   | MINS @ _____ PSIG   |      | <input type="checkbox"/> Soap Test                          |                |                             |   |
| ADDITIONAL INFORMATION <u>CUSTOMER VALVE LOCATION 3BBK 2LLB</u>  |   |   |      |   |                |                             |   |
|  |   |   |      |   |                |                             |   |
| PERSONS MAKING WELDS, FUSIONS, AND MECHANICAL FITTING JOINTS   |   |   |      |   |                |                             |   |
| EMPL NUM & CO  |   | <input type="checkbox"/> W <input type="checkbox"/> EF <input type="checkbox"/> SF <input type="checkbox"/> BF <input type="checkbox"/> M |      |   | EMPL NUM & CO  |                             | <input type="checkbox"/> W <input type="checkbox"/> EF <input type="checkbox"/> SF <input type="checkbox"/> BF <input type="checkbox"/> M |
| EMPL NUM & CO  |   | <input type="checkbox"/> W <input type="checkbox"/> EF <input type="checkbox"/> SF <input type="checkbox"/> BF <input type="checkbox"/> M |      |   | EMPL NUM & CO  |                             | <input type="checkbox"/> W <input type="checkbox"/> EF <input type="checkbox"/> SF <input type="checkbox"/> BF <input type="checkbox"/> M |
| POST-INSTALL LOCATING <input type="checkbox"/> PAINT <input type="checkbox"/> FLAGGED <input type="checkbox"/> LOCATED |   |   |      | OFFICE USE ONLY: REVIEWED BY AND DATE                       |                |                             |   |
| SKETCH THE SERVICE LINE IN THE SPACE ABOVE; INDICATE NORTH   |   |   |      | COMPLETE BOTH SIDES OF FORM                                 |                |                             |   |



Gas Standard

|                               |                                  |  |
|-------------------------------|----------------------------------|--|
| Effective Date:<br>06/01/2016 | <b>Service Line Record (SLR)</b> | Standard Number:<br><b>GS 3020.012</b> |
| Supersedes:<br>N/A            |                                  | Page 24 of 27                          |

**EXHIBIT C  
(5 OF 6)**

**Multiple Service with Company and Customer Valves (Primary)**

JOB ORDER # \_\_\_\_\_ FORM COMPLETED BY: \_\_\_\_\_

NEW (N)  REPLACE (R)  ABANDON (A)  REPAIR (F)  SURVEY (S)

|   |   |                   |          |  |   |                             |              |             |             |
|---|---|-------------------|----------|--|---|-----------------------------|--------------|-------------|-------------|
| SERVICE ADDRESS<br><b>21 Main St.</b>   |   |                   |          | CITY<br><b>Anywhere</b>                                    |   |                             |              |             |             |
| PSID/SITE ID<br><b>40011222</b>   |   | LOC NUM           |          | TAXING DISTRICT<br><b>123</b>                              |   | MAIN NUM                    |              |             |             |
| MAP NUM   |   | MAIN SIZE-MATL    |          | MAIN REFERENCE (LOCATION)                                  |   | SPECIAL CONDITION CODES     |              |             |             |
| EFV INSTALLED <input type="checkbox"/> YES <input type="checkbox"/> NO  |   | EFV MANUF & MODEL |          |  |   | GPS COORD                   |              |             |             |
| MAIN TO PROPERTY LINE OR CURB VALVE   | LENGTH  | SIZE              | MATERIAL | DEPTH (IN)   | OP PRESS  | DATE INSTL/ABN              | INSTALL MTHD | REPAIR DATE | REPAIR QNTD |
|   | LENGTH  | SIZE              | MATERIAL | DEPTH (IN)   | OP PRESS  | DATE INSTL/ABN              | INSTALL MTHD | REPAIR DATE | REPAIR QNTD |
| PROPERTY LINE OR CURB VALVE TO METER  | LENGTH  | SIZE              | MATERIAL | DEPTH (INCHES)   | DATE INSTALLED  | DATE ABN                    |              |             |             |
| RETIRED PIPE  | LENGTH  | SIZE              | MATERIAL | DEPTH (INCHES)   | DATE INSTALLED  | DATE ABN                    |              |             |             |
| MT *  | MASTER TAP REFERENCE (ADDR AND/OR PSID/SITE ID) |                   |          | CURB BOX LOCATION<br><b>18 FFB 22 RLB</b>                  |   | TAP LOCATION                |              | RISER CODE  |             |
| PRESSURE TESTED PER GAS STANDARD  |   |                   |          | BY (SIGNATURE); THEN PRINT NAME & EMPLOYEE NUM & COMP NAME |   |                             |              |             |             |
| <input type="checkbox"/> SRV LINE M-PL/CV   |   | MINS @ _____      |          | PSIG <input type="checkbox"/> Soap Test                    |   | <b>J. Doe J. Doe 123456</b> |              |             |             |
| <input type="checkbox"/> SRV LINE PL/CV-MTR   |   | MINS @ _____      |          | PSIG <input type="checkbox"/> Soap Test                    |   |                             |              |             |             |
| ADDITIONAL INFORMATION<br><b>CUSTOMER VALVE LOCATION 3FM</b>  |   |                   |          |  |   |                             |              |             |             |
|   |   |                   |          |  |   |                             |              |             |             |
| PERSONS MAKING WELDS, FUSIONS, AND MECHANICAL FITTING JOINTS  |   |                   |          |  |   |                             |              |             |             |
| EMPL NUM & CO <input type="checkbox"/> W <input type="checkbox"/> EF <input type="checkbox"/> SF <input type="checkbox"/> BF <input type="checkbox"/> M |   |                   |          |  | EMPL NUM & CO <input type="checkbox"/> W <input type="checkbox"/> EF <input type="checkbox"/> SF <input type="checkbox"/> BF <input type="checkbox"/> M |                             |              |             |             |
| EMPL NUM & CO <input type="checkbox"/> W <input type="checkbox"/> EF <input type="checkbox"/> SF <input type="checkbox"/> BF <input type="checkbox"/> M |   |                   |          |  | EMPL NUM & CO <input type="checkbox"/> W <input type="checkbox"/> EF <input type="checkbox"/> SF <input type="checkbox"/> BF <input type="checkbox"/> M |                             |              |             |             |
| POST INSTALL LOCATING <input type="checkbox"/> PAINT <input type="checkbox"/> FLAGGED <input type="checkbox"/> LOCATED                                  |   |                   |          |  | OFFICE USE ONLY: REVIEWED BY AND DATE   |                             |              |             |             |
| SKETCH THE SERVICE LINE IN THE SPACE ABOVE; INDICATE NORTH  |   |                   |          |  | COMPLETE BOTH SIDES OF FORM   |                             |              |             |             |



Gas Standard

|                               |                                  |  |
|-------------------------------|----------------------------------|--|
| Effective Date:<br>06/01/2016 | <b>Service Line Record (SLR)</b> | Standard Number:<br><b>GS 3020.012</b> |
| Supersedes:<br>N/A            |                                  | Page 25 of 27                          |

**EXHIBIT C  
(6 OF 6)**

**Multiple Service with Company and Customer Valves (Secondary)**

JOB ORDER # 01253700 FORM COMPLETED BY: J. Doe

NEW (N)  REPLACE (R)  ABANDON (A)  REPAIR (F)  SURVEY (S)

|  |  |   |   |                         |                |
|--|--|---|---|-------------------------|----------------|
| SERVICE ADDRESS<br><b>25 MAIN ST.</b>  |  |   |   | CITY<br><b>Anywhere</b> |                |
| PSID/SITE ID<br><b>40011223</b>  |  | LOC NUM   | TAXING DISTRICT<br><b>123</b>   | MAIN NUM                |                |
| MAP NUM  | MAIN SIZE-MATL   | MAIN REFERENCE (LOCATION)   |   | SPECIAL CONDITION CODES |                |
| EFV INSTALLED <input type="checkbox"/> YES <input type="checkbox"/> NO   | EFV MANUF & MODEL  |   | GPS COORD   |                         |                |
| MAIN TO PROPERTY LINE OR CURB VALVE  | LENGTH   | SIZE  | MATERIAL  | DEPTH (IN)              | OF PRESS       |
| PROPERTY LINE OR CURB VALVE TO METER   | LENGTH   | SIZE  | MATERIAL  | DEPTH (IN)              | OF PRESS       |
| RETIRED PIPE   | LENGTH   | SIZE  | MATERIAL  | DEPTH (INCHES)          | DATE INSTALLED |
| MT<br><b>+</b>   | MASTER TAP REFERENCE (ADDR AND/OR PSID/SITE ID)<br><b>40011222</b> |   | CURB BOX LOCATION<br><b>40011222</b>  |                         | RISER CODE     |
| PRESSURE TESTED PER GAS STANDARD<br><input type="checkbox"/> SRV LINE M-PL/CV _____ MINS @ _____ PSIG <input type="checkbox"/> Soap Test<br><input type="checkbox"/> SRV LINE PL/CV-MTR _____ MINS @ _____ PSIG <input type="checkbox"/> Soap Test |  |   | BY (SIGNATURE); THEN PRINT NAME & EMPLOYEE NUM & COMP NAME)<br><u>J. Doe</u> <b>J. Doe 123456</b> |                         |                |
| ADDITIONAL INFORMATION<br><b>CUSTOMER VALVE LOCATION 4EM</b>   |  |   |   |                         |                |
|  |  |   |   |                         |                |
| <b>PERSONS MAKING WELDS, FUSIONS, AND MECHANICAL FITTING JOINTS</b>  |  |   |   |                         |                |
| EMPL NUM & CO  |  | <input type="checkbox"/> W <input type="checkbox"/> EF <input type="checkbox"/> SF <input type="checkbox"/> BF <input type="checkbox"/> M |   | EMPL NUM & CO           |                |
| EMPL NUM & CO  |  | <input type="checkbox"/> W <input type="checkbox"/> EF <input type="checkbox"/> SF <input type="checkbox"/> BF <input type="checkbox"/> M |   | EMPL NUM & CO           |                |
| POST INSTALL LOCATING <input type="checkbox"/> PAINT <input type="checkbox"/> FLAGGED <input type="checkbox"/> LOCATED   |  | OFFICE USE ONLY: REVIEWED BY AND DATE   |   |                         |                |

SKETCH THE SERVICE LINE IN THE SPACE ABOVE; INDICATE NORTH COMPLETE BOTH SIDES OF FORM



Distribution Operations

Gas Standard

|                               |                                  |  |
|-------------------------------|----------------------------------|--|
| Effective Date:<br>06/01/2016 | <b>Service Line Record (SLR)</b> | Standard Number:<br><b>GS 3020.012</b> |
| Supersedes:<br>N/A            |                                  | Page 26 of 27                          |

**EXHIBIT D  
(1 OF 2)**

Examples of Completed SLRs

**New Installation**

JOB ORDER # 16-3874575-00 FORM COMPLETED BY: J. Doe

NEW (N)  REPLACE (R)  ABANDON (A)  REPAIR (F)  SURVEY (S)

|   |   |  |   |                         |                |  |             |             |             |
|---|---|--|---|-------------------------|----------------|--|-------------|-------------|-------------|
| SERVICE ADDRESS<br><u>3931 Marmaduke Dr.</u>                                      |   |  |   | CITY<br><u>Anywhere</u> |                |  |             |             |             |
| PSID/SITE ID<br><u>560995800</u>  | LOC NUM<br><u>1234</u>  | TAXING DISTRICT<br><u>123</u>              | MAIN NUM<br><u>35040007</u>   | OP PRESS<br><u>MP</u>   |                |  |             |             |             |
| MAP NUM<br><u>1234567M</u>  | MAIN SIZE-MATL<br><u>020 P</u>  | MAIN REFERENCE (LOCATION)<br><u>2 BKCU</u> | SPECIAL CONDITION CODES<br><u>KLGE</u>  |                         |                |  |             |             |             |
| EFV INSTALLED <input checked="" type="checkbox"/> YES <input type="checkbox"/> NO | EFV MANUF & MODEL<br><u>UMAC 700</u>  |  | GPS COORD<br><u>-81.157852 34.106491</u>  |                         |                |  |             |             |             |
| MAIN TO PROPERTY LINE OR CURB VALVE   | LENGTH  | SIZE                                       | MATERIAL  | DEPTH (IN)              | OP PRESS       | DATE INSTL/ABN   | INSTALL MTH | REPAIR DATE | REPAIR KIND |
|   | <u>1</u>  | <u>010</u>                                 | <u>P</u>  | <u>36</u>               | <u>MP</u>      | <u>3-30-16</u>   | <u>OC</u>   |             |             |
| PROPERTY LINE OR CURB VALVE TO METER  | LENGTH  | SIZE                                       | MATERIAL  | DEPTH (IN)              | OP PRESS       | DATE INSTL/ABN   | INSTALL MTH | REPAIR DATE | REPAIR KIND |
|   | <u>63</u>   | <u>010</u>                                 | <u>P</u>  | <u>36</u>               | <u>MP</u>      | <u>3-30-16</u>   | <u>OC</u>   |             |             |
| RETIRED PIPE  | LENGTH  | SIZE                                       | MATERIAL  | DEPTH (INCHES)          | DATE INSTALLED |  | DATE ABN    |             |             |
| MT  | MASTER TAP REFERENCE (ADDR AND/OR PSID/SITE ID)   |  |   | CURB BOX LOCATION       |                | TAP LOCATION   |             | RISER CODE  |             |
|   |   |  |   | <u>NCV-EFV</u>          |                | <u>50FFB 14B</u>   |             | <u>EC10</u> |             |
| PRESSURE TESTED PER GAS STANDARD  |   |  |   |                         |                | BY (SIGNATURE); THEN PRINT NAME & EMPLOYEE NUM & COMP NAME |             |             |             |
| <input checked="" type="checkbox"/> SRV LINE M-PL/CV                              |   | <u>10</u>                                  | MINS @  | <u>90</u>               | PSIG           | <input checked="" type="checkbox"/> Soap Test              |             |             |             |
| <input checked="" type="checkbox"/> SRV LINE PL/CV-MTR                            |   | <u>10</u>                                  | MINS @  | <u>90</u>               | PSIG           | <input checked="" type="checkbox"/> Soap Test              |             |             |             |
| ADDITIONAL INFORMATION<br><u>J. Doe J. Doe 123456</u>                             |   |  |   |                         |                |  |             |             |             |
| PERSONS MAKING WELDS, FUSIONS, AND MECHANICAL FITTING JOINTS                      |   |  |   |                         |                |  |             |             |             |
| EMPL NUM & CO<br><u>1234 MILLER</u>   | <input type="checkbox"/> W <input checked="" type="checkbox"/> EF <input checked="" type="checkbox"/> SF <input type="checkbox"/> BF <input type="checkbox"/> M | EMPL NUM & CO                              | <input type="checkbox"/> W <input type="checkbox"/> EF <input type="checkbox"/> SF <input type="checkbox"/> BF <input type="checkbox"/> M |                         |                |  |             |             |             |
| EMPL NUM & CO   | <input type="checkbox"/> W <input type="checkbox"/> EF <input type="checkbox"/> SF <input type="checkbox"/> BF <input type="checkbox"/> M                       | EMPL NUM & CO                              | <input type="checkbox"/> W <input type="checkbox"/> EF <input type="checkbox"/> SF <input type="checkbox"/> BF <input type="checkbox"/> M |                         |                |  |             |             |             |
| POST INSTALL LOCATING   | <input checked="" type="checkbox"/> PAINT <input checked="" type="checkbox"/> FLAGGED <input checked="" type="checkbox"/> LOCATED                               | OFFICE USE ONLY: REVIEWED BY AND DATE      |   |                         |                |  |             |             |             |



|                               |                                  |  |
|-------------------------------|----------------------------------|--|
| Effective Date:<br>06/01/2016 | <b>Service Line Record (SLR)</b> | Standard Number:<br><b>GS 3020.012</b> |
| Supersedes:<br>N/A            |                                  | Page 27 of 27                          |

**EXHIBIT D  
(2 OF 2)**

Form GS 3020.012-1 (rev 01/16) FORM WILL BE SCANNED - USE BLACK INK

### SERVICE LINE RECORD (SLR) COMPLETE BOTH SIDES OF FORM

| MATERIAL   |              |      |           |         |              |       |           |
|------------|--------------|------|-----------|---------|--------------|-------|-----------|
| SSN        | DESCRIPTION  | SIZE | CITY INST | SSN     | DESCRIPTION  | SIZE  | CITY INST |
| 0945-041   | PIPE         | 010  | 63        | 4253303 | Warning tape |       | 63        |
| 44-84-1247 | Difer        | 010  | 1         | 7447578 | Wire         | 12AWG | 66        |
| 16-03-015  | EFV          | 700  | 1         |         |              |       |           |
| 74-80-100  | TAP TREE     | 2x1  | 1         |         |              |       |           |
| 43-04-153  | COUPLING SJ  | 010  | 2         |         |              |       |           |
| 44 84 0823 | Wall Bracket | 9"   | 1         |         |              |       |           |
| 44 84 256  | meter rest   |      | 1         |         |              |       |           |
| 44 84 080  | Stabilizer   |      | 1         |         |              |       |           |

FOR MORE INFORMATION, CONSULT GS 3020.012

#### REFERENCE CODES

|   |   |   |
|---|---|---|
| <p><b>OR. PRESSURE</b></p> <p>LP LOW PRESSURE<br/>IP INTERMEDIATE PRESSURE<br/>MP MEDIUM PRESSURE<br/>HP HIGH PRESSURE</p> <p><b>MASTER TAP</b></p> <p>LEAVE BLANK IF ONLY 1 CUST ON SL (CY, MD, OH, PA, VA)</p> <p>USE DASH (-) IF ONLY 1 CUST ON SL (WA)</p> <p>* PRIMARY REF BY CB<br/>+ OTHER DOWNSIDE CUST<br/>P SPLIT SERVICE; P/SM SL<br/>S SPLIT SERVICE; SEC SL</p> <p><b>MAIN REFERENCE LOCATION</b></p> <p>EXAMPLE: 600 S PAV</p> <p>WHERE:<br/>010 = DISTANCE IN FEET<br/>S = SOUTH OF<br/>NLU = REF OBJECT; NORTH CURB</p> <p>FOR ROOFTOP, ADD "RT"</p> <p><b>DESIGNATING OR. &amp; OTHER LOCATIONS</b></p> <p>EXAMPLE: 32 FFB 3 RNB<br/>32 FT FRONT OF FRONT BLDG EDGE<br/>3 FT RT RIGHT OF RIGHT BLDG EDGE</p> <p><b>RISER CODES</b></p> <p>USE RISER CODE PROVIDED BY VENTIL OR WWS; OR CONTAINED IN DIS CONTROL TABLES</p> <p><b>INSTALLATION METHOD</b></p> <p>OC OPEN CUT<br/>TO TIE OVER<br/>PI PLASTIC INSERT<br/>TT TRENCHLESS TECH</p> | <p><b>OBJECT CODES</b></p> <p>B BLDG EDGE<br/>BK BACK<br/>C CORNER<br/>CEL CENTER OF EB LANE<br/>CLP CENTER OF PAVEMENT<br/>CLR CENTER OF RT OF WAY<br/>CPL CENTER OF NB LANE<br/>CPL CENTER OF PROPERTY<br/>CSL CENTER OF SB LANE<br/>CU CURB<br/>CWL CENTER OF WB LANE<br/>D DRIVEWAY EDGE<br/>EP EDGE OF PAVEMENT<br/>ES EDGE OF SIDEWALK<br/>F FRONT<br/>G GARAGE EDGE<br/>L LEFT<br/>M METER<br/>P PORCH EDGE<br/>PAD TRASH PAD<br/>PL PROPERTY LINE<br/>R RIGHT<br/>W WATER VALVE</p> <p><b>MATERIAL CODES</b></p> <p>CI CAST IRON<br/>CU COPPER<br/>OT OTHER<br/>P PLASTIC<br/>PI PLASTIC INSERT<br/>S STEEL<br/>ST STEEL, TREATED<br/>WA WROUGHT IRON</p> <p><b>DATE FORMAT</b></p> <p>ALL DATES TO BE IN MM-DD-YYYY FORMAT</p> <p>EXAMPLE: 08-11-2007<br/>EXAMPLE: 11-11-2009</p> <p><b>JOINT TYPES</b></p> <p>BF BUTT FUSION<br/>EF ELECTROFUSION<br/>SF SOCKET FUSION<br/>ME MECHANICAL FITTING<br/>W WELDED (STEEL)</p> | <p><b>KEY MODEL &amp; MODEL</b></p> <p>UMAC 300<br/>UMAC 400<br/>UMAC 700<br/>UMAC 1000<br/>UMAC 1800<br/>UMAC 2800<br/>UMAC 3500<br/>UMAC 50,000</p> <p>IF NOT ON LIST, WRITE IN MARKUP &amp; MODEL USED</p> <p><b>SPECIAL CONDITIONS</b></p> <p>A ANCOE INSTALLED<br/>B BURIED REGULATOR<br/>C CUST AMODE; CO INSTALL<br/>E ELECTRONIC MARKER<br/>F COPPER FITTING ON TIE<br/>G GAS FLOW LIMITER/TV<br/>H TAP BLW HARD SURFACE<br/>I INSULATOR INSTALLED<br/>J HT INSTALLED<br/>K EPV TAPPED<br/>L LOC WIRE TIED TO PLASTIC MAIN WIRE<br/>M MUYT SHV, 1.5L 1 METR<br/>N METR BARBIEZ INSTALLED<br/>P PLASTIC VALVE<br/>Q FARM TAP<br/>S TEST STATION<br/>T TAP TREE IS MECH PLASTIC<br/>V VLV BRASS BUSTLER<br/>W INSTA-TITE<br/>W METER MOVED CUT<br/>* SEE ADDL INFORMATION</p> <p><b>SIZE CODES &amp; ANGLE SIZES (MILAE)</b></p> <p>005 1/2"<br/>007 3/4"<br/>010 1"<br/>012 1-1/4"<br/>015 1-1/2"<br/>020 2"<br/>030 3"<br/>040 4"</p> |
|---|---|---|





**Distribution Operations**

**Gas Standard**

|                               |   |  |
|-------------------------------|---|--|
| Effective Date:<br>04/01/2011 | <b>Service Line<br/>Valve Requirements and Location</b> | Standard Number:<br><b>GS 3020.020</b> |
| Supersedes:<br>03/01/2010     |   | Page 1 of 2                            |

Companies Affected:

|  |   |   |
|--|---|---|
| <input checked="" type="checkbox"/> NIPSCO | <input checked="" type="checkbox"/> CGV | <input checked="" type="checkbox"/> CMD |
|  | <input checked="" type="checkbox"/> CKY | <input checked="" type="checkbox"/> COH |
|  | <input type="checkbox"/> CMA            | <input checked="" type="checkbox"/> CPA |

**REFERENCE** 49 CFR 192.363, 192.365  
CKY: 807 KAR 5:022, Section 9(17)(a)1

**1. GENERAL**

Each service line must have a valve installed in it, such as a curb or meter valve, that is properly rated for the pressure and temperature of its application.

A valve incorporated in a meter bar, that allows the meter to be bypassed, may not be used as a service line valve.

A soft seat service line valve may not be used if its ability to control the flow of gas could be adversely affected by exposure to anticipated heat.

Each service-line valve on a high-pressure service line, installed aboveground or in an area where the blowing of gas would be hazardous, must be designed and constructed to minimize the possibility of the removal of the core of the valve with other than specialized tools.

For excess flow valve (EFV) installation requirements and guidance, refer to Gas Standard GS 3020.100, "Service Lines Excess Flow Valves."

**2. CURB VALVES**

A curb valve is an underground service line valve installed near the customer's property line. Curb valves should not be installed or retained except where required by at least one of the following conditions.

- a. There is not an accessible above ground shut-off device located outside of the building.
- b. The entire service line (from main to meter) is not plastic pipe.
- c. The service tap location at the main cannot be verified.
- d. The service line size is 3 inches in diameter or larger.
- e. State tariff or regulations require one.

Curb valves may be installed on each leg of split services running toward the property being served, but not parallel with the front property line. Their installation is recommended for

*This document is considered CONTROLLED only when viewed electronically on the Company's intranet. Printed or other electronic copies may not be current, and the intranet version should be used to verify.*



**Distribution Operations**

**Gas Standard**

|                               |   |  |
|-------------------------------|---|--|
| Effective Date:<br>04/01/2011 | <b>Service Line<br/>Valve Requirements and Location</b> | Standard Number:<br><b>GS 3020.020</b> |
| Supersedes:<br>03/01/2010     |   | Page 2 of 2                            |

operations that use pressure drop testing to identify leak sources on customer service lines. In addition, the orientation of the curb valve will indicate which customer the valve controls and the position of the valve operation.

Where it is considered necessary to provide for added control of the piping system, such as a shopping center or other major complex, a curb valve may be installed.

The curb valve on all service lines 2 inches in diameter and larger shall have a 2 inch square operator connection.

**3. LOCATION**

Each service line must have a shutoff valve in a readily accessible location that, if feasible, is outside of the building. The valve must be installed upstream of the regulator or, if there is no regulator, upstream of the meter.

Each underground service-line valve (i.e., curb valve), if installed, should be located at or near the customer's property line or easement, and shall be installed so that the open/closed position is easily recognized.

The curb valve must be located in a covered, durable curb box or standpipe that: 1) allows for ready operation of the valve, and 2) is supported independently of the service line. The curb box should be centered over the curb valve and the height of the box should be adjusted to the finished surface level. The curb valve and curb box support, used for plastic service lines, shall be installed on well-compacted soil.

**4. RECORDS**

All applicable Company records, including hardcopy forms and computer databases, shall be updated with the existence and location references for all buried service line valves. This information shall be maintained for the life of the service line valve.





Distribution Operations

|                               |  |  |
|-------------------------------|--|--|
| Effective Date:<br>03/01/2010 | <b>Service Line<br/>Connections to Main Piping</b> | Standard Number:<br><b>GS 3020.030</b> |
| Supersedes:<br>N/A            |  | Page 1 of 5                            |

Companies Affected:

|  |   |   |
|--|---|---|
| <input checked="" type="checkbox"/> NIPSCO<br>Effective Date: 09/01/2012 | <input checked="" type="checkbox"/> CGV | <input checked="" type="checkbox"/> CMD |
|  | <input checked="" type="checkbox"/> CKY | <input checked="" type="checkbox"/> COH |
|  | <input checked="" type="checkbox"/> CMA | <input checked="" type="checkbox"/> CPA |

**REFERENCE** 49 CFR 192.367

**1. GENERAL**

This standard covers the general requirements for connecting a service line to the transmission line or distribution main. As used in this standard, the term “mains” also refers to transmission lines.

Refer to Gas Standard GS 3020.100, “Service Lines Excess Flow Valves” for the excess flow valve requirements.

All materials must have the proper pressure rating for their application.

The Company’s Representative, whether employee or contractor:

- a. shall inspect each project/job site to ensure that all work complies with Company procedures and is done in accordance with all governmental regulations; and
- b. has the authority to order the removal or correction of any portion of construction, welds, fusions, mechanical joints, coatings, backfill, etc. that do not meet the Company's requirements.

**1.1 Location of Connection to the Main**

Service line connections to mains by service tees must be located on the top of the main or, if not practical, on the side of the main.

All other service line connections shall be placed on the top half of the main, not being placed any lower than the three or nine o'clock position without prior approval by the Operating Center Manager, Engineering Manager, or other responsible management person. If the service connection is placed on the lower half of the main, a suitable protective device shall be installed to minimize the possibility of dust and moisture being carried from the main into the service line. The service line piping shall be brought to a higher elevation than the main as near as practical after the connection. Appurtenances, such as excess flow valves (EFVs) or curb valves shall be installed on the higher-elevation piping.

*This document is considered CONTROLLED only when viewed electronically on the Company's intranet. Printed or other electronic copies may not be current, and the intranet version should be used to verify.*



Distribution Operations

|                               |  |  |
|-------------------------------|--|--|
| Effective Date:<br>03/01/2010 | <b>Service Line<br/>Connections to Main Piping</b> | Standard Number:<br><b>GS 3020.030</b> |
| Supersedes:<br>N/A            |  | Page 2 of 5                            |

**1.2 Type of Connection to the Main**

Connections to the main should be welded for steel mains and fused for plastic mains. Oxy-Acetylene welding on pressurized mains is prohibited.

The use of mechanical saddles for steel and plastic mains is permitted as an alternative, and shall be limited to mains with **MAOP's** of 99 psig or less depending on the fittings' pressure rating.

Service line connections smaller than 2" in diameter should be made by a service tee that shall be a shut-off type tee, and have the minimum tap-hole size specified in Table 1. Service connections 2" in diameter and larger may be made with standard main fittings, such as a 3-way tee, a side-tap branch connection, a spherical tee, or an in-line tee. Refer to Gas Standard GS 1680.010, "Tie-Ins and Tapping Pressurized Pipelines" for additional information.

**Table 1 – Service Tee Minimum Tap-Hole Sizes**

| <u>Main Pressure</u> | <u>Steel Service Line with Steel Service Tee</u> |                                |                                    |                             |
|----------------------|--|--------------------------------|------------------------------------|-----------------------------|
|                      | <u>Pipe Size</u>                                 |                                |                                    |                             |
|                      | <u>3/4" IPS</u>                                  | <u>1" IPS<sup>(1)(2)</sup></u> | <u>1 1/4" IPS<sup>(2)(3)</sup></u> | <u>2" IPS<sup>(3)</sup></u> |
| Low Pressure         |  | 3/4"                           | 3/4"                               | 1"                          |
| 1 to 10 psig         |  | 3/8"                           | 3/4"                               | 7/8"                        |
| 2 to 60 psig         |  | 3/8"                           | 3/4"                               | 7/8"                        |
| 61 to 99 psig        |  | 3/8"                           | 3/4"                               | 7/8"                        |
| 100 to 300 psig      | 1/4" or 5/16"                                    | 3/8"                           | 3/4"                               | 7/8"                        |
| Over 300 psig        | 1/4" or 5/16"                                    | 3/8"                           | 5/8"                               | 7/8"                        |

| <u>Main Pressure</u> | <u>Plastic Service Line with Plastic Service Tee</u> |                             |                                 |                             |
|----------------------|--|-----------------------------|---------------------------------|-----------------------------|
|                      | <u>Pipe Size</u>                                     |                             |                                 |                             |
|                      | <u>1/2" CTS<sup>(4)</sup></u>                        | <u>1" CTS<sup>(5)</sup></u> | <u>1 1/4" IPS<sup>(6)</sup></u> | <u>2" IPS<sup>(7)</sup></u> |
| Low Pressure         |  | 3/4"                        | 3/4"                            | 1-1/4"                      |
| 1 to 10 psig         | 3/8"   | 3/4"                        | 3/4"                            | 1-1/4"                      |
| 2 to 60 psig         | 3/8"   | 3/4"                        | 3/4"                            | 1-1/4"                      |
| 61 to 99 psig        | 3/8"   | 3/4"                        | 3/4"                            | 1-1/4"                      |

Notes:

(1) For steel 1" service lines at all Main Pressures except Low Pressure, a 3/8" solid punch (Continental) may be substituted for a 3/8" punch-valve when the pipe wall exceeds 0.280".

(2) Continental: 1416 (1" body) & 9928 (saddle tee) - 3/4" Punch-Valve (3/8" max. for 1-1/4" saddle)



Distribution Operations

|                               |  |  |
|-------------------------------|--|--|
| Effective Date:<br>03/01/2010 | <b>Service Line<br/>Connections to Main Piping</b> | Standard Number:<br><b>GS 3020.030</b> |
| Supersedes:<br>N/A            |  | Page 3 of 5                            |

1521 (1-1/4" body w/ 1" valve) - use Mueller #78875 or Skinner #11 cutter for 3/4" LP taps

1302 (3/4" body) - 3/8" Punch-Valve - use only for minimum Main Pressure of 2 psig or greater

(3) Continental: 9923 (2" body) - 1-7/8" max. cutter size (Mueller or TD Williamson)  
 Mueller: No-Blo 1-1/4" body or 2" body

(4) Dresser 388 - 1/2" cutter

(5) Central E/F - 0.75" cutter; Dresser 388 – 1/2" cutter

(6) Central E/F - 0.75" cutter

(7) Central E/F - 1 1/4" cutter for 2" mains, 1 1/2" cutter for over 2" main size; Continental Super Eliminator 1 1/2" cutter

**1.3 Connection of the Service Line to the Service Tee**

It is preferred for connections of the service lines to the service tees to be fused for plastic piping and welded for steel piping.

Mechanical connections, such as made by stab-style or compression fittings, may be used depending on the type of materials involved and circumstances of installation.

If using compression fittings, the compression-type service line connection to the service tee must be resistant to pullout, especially from contraction of the piping.

**2. PLASTIC SERVICE LINES**

The connection between a plastic service line and the service tee at the main is particularly susceptible to excessive bending and shear stresses. It is important to provide proper compaction of the backfill under the service line at this location to avoid damage to it or the connection to the tee. Protective plastic sleeves or bridging may also be used where excess stresses are anticipated on the connection. See Gas Standard GS 3020.010, "Service Line Installation" for further information.

Buried electronic markers should be installed for all plastic service line connections to mains. Electronic markers can provide a secondary means to locate the main, and can provide for accurate location of pipeline connection features. The electronic markers shall be installed according to Gas Standard GS 3010.050, "Installation of Pipe in a Ditch."

**2.1 Connecting to Plastic Mains**

The preferred connection for 2" in diameter or less plastic service lines to plastic mains is to fuse a plastic service tee to the main, and fuse the service line, or fittings fused to the service line, to the service tee. The use of a protective sleeve over the outlet of the tee is recommended, especially where compaction of the backfill under the connection



Distribution Operations

|                               |  |  |
|-------------------------------|--|--|
| Effective Date:<br>03/01/2010 | <b>Service Line<br/>Connections to Main Piping</b> | Standard Number:<br><b>GS 3020.030</b> |
| Supersedes:<br>N/A            |  | Page 4 of 5                            |

may not be adequate.

Mechanical connection saddle tees should only be used as an alternative, such as for dissimilar plastics or where installation conditions will not allow for fusion. Service lines are connected to mechanical tees by mechanical fittings, typically integral to the tee.

**2.2 Connecting to Steel Mains**

The preferred connection for less than 2” diameter plastic service lines to steel mains is to weld a steel service tee to the main, and mechanically connect the service line, or fittings connected to the service line, to the service tee, such as by a pull-out resistant compression fitting. Bolt-on mechanical saddle tees should only be used as an alternative to a welded tee. Welding a steel-to-plastic transition fitting in-line is preferred for 2” diameter or greater service lines, and may be used for less than 2” diameter lines. Refer to Gas Standard GS 1680.020, “Plastic to Steel Transition Connections” for installation requirements.

Plastic service line connections to service tees by mechanical joints can experience excessive stress due to bending of the piping. Bending of plastic piping can overstress the joints and lead to premature failures. Proper backfill compaction and service line support is extremely important.

**2.3 Connecting to Cast Iron or Ductile Iron Mains**

Each service line connected to a cast iron or ductile iron main must be connected by a mechanical clamp or by drilling and tapping the main.

Refer to Gas Standard GS 1680.010, “Tie-Ins and Tapping Pressurized Pipelines” for tapping requirements on cast iron and ductile iron mains. Reinforcement of the tap may be required for larger tap hole sizes.

**3. STEEL SERVICE LINES**

New steel service lines shall not be installed on plastic, cast iron, or ductile iron mains. This will avoid creating isolated steel services and their corrosion control requirements.

The preferred connection for 2” in diameter or less steel service lines to steel mains is to weld a steel service tee to the main, and weld the service line to the tee along with any other required fittings. The use of mechanical saddle tees should only be an alternative, and is limited to systems with an **MAOP** of 99 psig or less, depending on the pressure rating of the required fittings.

All service tee connections to steel mains shall be welded for either tee sizes greater than 2” in diameter or on systems with an **MAOP** greater than 99 psig.



Distribution Operations

|                               |  |  |
|-------------------------------|--|--|
| Effective Date:<br>03/01/2010 | <b>Service Line<br/>Connections to Main Piping</b> | Standard Number:<br><b>GS 3020.030</b> |
| Supersedes:<br>N/A            |  | Page 5 of 5                            |

All service line connections to service tees on systems with an **MAOP** greater than 125 psig shall be welded.

**4. RECORDS**

**4.1 Company Forms/Database**

Where there is no curb valve, the tap location shall be provided on the appropriate Company form and in applicable computer databases.

**4.2 Records Retention**

The service line tap information shall be retained for the life of the service line.



**Distribution Operations**

**Gas Standard**

|                               |  |  |
|-------------------------------|--|--|
| Effective Date:<br>06/01/2016 | <b>Meter Set Assembly Location and<br/>Installation Requirements</b> | Standard Number:<br><b>GS 3020.035</b> |
| Supersedes:<br>N/A            |  | Page 1 of 12                           |

Companies Affected:

|                                 |   |   |
|---------------------------------|---|---|
| <input type="checkbox"/> NIPSCO | <input checked="" type="checkbox"/> CGV | <input checked="" type="checkbox"/> CMD |
|                                 | <input checked="" type="checkbox"/> CKY | <input checked="" type="checkbox"/> COH |
|                                 | <input checked="" type="checkbox"/> CMA | <input checked="" type="checkbox"/> CPA |

**REFERENCE** 49 CFR Part 192.353, 192.355, 192.357, 192.467, 192.479, 24 CFR Part 3280

**1. GENERAL**

Each meter and service regulator, whether inside or outside a building, must be installed in a readily accessible location and be protected from corrosion and other damage, including, if installed outside a building, vehicular damage that may be reasonably anticipated.

For the purpose of this standard, "readily accessible" means having direct access (e.g., located outdoors), without the need to remove/open any panel, door, or similar obstruction, and with ample space for maintenance or replacement of the meter and/or regulator.

The purpose of this standard is to provide guidance for the location and installation of meter set assemblies.

For the purpose of this standard, a meter set assembly also includes, where installed, first/second/third cut (as required) service regulators.

**2. MATERIALS**

Company approved drawings should be used to fabricate meter set assemblies. In cases where a Company approved drawing is not available, use only Company stocked materials (i.e., items stocked by warehousing partner) or materials identified on Company approved drawings. Materials used shall meet or exceed the maximum allowable operating pressure (MAOP) or design pressure of the inlet and outlet pressure systems, respectively. Contact local Field Engineering for design assistance regarding high pressure meter set assemblies with no corresponding Company approved drawing, if necessary.

The use of close all-thread nipples is prohibited.

Connections made of lead or other easily damaged material shall not be used in the installation of meters or regulators.

**3. PROTECTION FROM ATMOSPHERIC CORROSION**

All above ground piping that is part of the meter set assembly shall be coated or painted with an approved material in accordance with GS 1420.050 "Coating Methods for Fabricated Stations & Settings."

*This document is considered CONTROLLED only when viewed electronically on the Company's intranet. Printed or other electronic copies may not be current, and the intranet version should be used to verify.*



**Distribution Operations**

**Gas Standard**

|                               |  |  |
|-------------------------------|--|--|
| Effective Date:<br>06/01/2016 | <b>Meter Set Assembly Location and<br/>Installation Requirements</b> | Standard Number:<br><b>GS 3020.035</b> |
| Supersedes:<br>N/A            |  | Page 2 of 12                           |

Refer to the applicable GS 1450.010 “Atmospheric Corrosion” and GS 1650.020 “Inspection of Risers and Meter Set Assemblies for Abnormal Operating Conditions” for inspection, documentation and remediation requirements with respect to atmospheric corrosion.

**4. METER SET ASSEMBLY LOCATION**

The preferred location of a meter set assembly is outside a building.

The meter set assembly should be installed in a location where damage from outside forces is not reasonably expected to occur. Examples include, but are not limited to, vehicular traffic, snow and ice, construction equipment, and falling objects. Avoid installing the meter set assembly under fire escapes.

Outside meter set assemblies shall be located such that potential damage from snow accumulation and/or falling ice and snow is limited. Locating the meter set assembly along an outside building wall under a roof gable or overhang should be sufficient protection.

The following factors should be considered when selecting a suitable location for the meter set assembly.

- a. Type of road (e.g. private, residential, federal or state highway, limited access highway).
- b. Road attributes (e.g. curb/no curb, guide rail/no guide rail, etc.).
- c. Function of driveway (e.g., residential, commercial, industrial).
- d. Type of off-road activity (e.g., four-wheeling, snowmobiling, farming operations).
- e. Natural barriers, (e.g. swales, earth embankments, terrain, etc.).
- f. Weather-related conditions (e.g., ice, snow, snow removal).

When it is not possible to install the meter set assembly as outlined in this section, protection shall be provided as indicated in GS 3020.040 “Meter Set Assembly Protection Residential and Small Commercial.”

When it is necessary to install a meter set assembly inside a building, refer to Section 6 “Meters and Regulators Installed Inside a Building” below for meter and regulator location requirements.

**5. MANIFOLD METER INSTALLATIONS**

A master meter valve shall be installed on the riser, except as noted below. Individual meter valves controlling each meter shall also be installed.

Exception: For an existing manifold of less than six (6) meters served by a Low Pressure system, no master meter valve is required.



**Distribution Operations**

**Gas Standard**

|                               |  |  |
|-------------------------------|--|--|
| Effective Date:<br>06/01/2016 | <b>Meter Set Assembly Location and<br/>Installation Requirements</b> | Standard Number:<br><b>GS 3020.035</b> |
| Supersedes:<br>N/A            |  | Page 3 of 12                           |

If a single service regulator is installed serving multiple meters, a master meter valve shall be installed upstream of the service regulator on the riser in addition to individual meter valves controlling each meter.

If individual service regulators are installed for each meter, the meter valves shall be installed upstream of each service regulator in addition to the master meter valve installed on the riser.

On new or replaced manifold meter settings, each meter shall be identified with a weather proof tag at the meter valve, meter bar, or house piping, as close as practical to the meter, indicating the apartment number or address that it serves. On existing meter manifolds, when gas is turned on to one or more of the meters on the manifold, the meter shall be identified with a weather proof tag at the meter valve, meter bar, or house piping as close as practical to the meter indicating the apartment number or address that it serves.

**6. METERS AND REGULATORS INSTALLED INSIDE A BUILDING**

Meters installed inside a building must be located in a ventilated space and not less than three (3) feet from any source of ignition or heat which might damage the meter.

Each service regulator installed within a building must be located as near as practical to the point of service line entrance. Refer to Section 8 below for regulator venting requirements.

Where feasible, the upstream regulator in a series must be located outside the building, unless it is located in a separate metering or regulating building.

For meter set assemblies installed inside a warehouse, manufacturing, or similar building, consider protection from mobile equipment (e.g., forklifts) and potential falling objects.

**7. METER CLEARANCE**

The distance between the meter and any obstruction to the sides, rear, top, or bottom should be a minimum of six (6) inches but in no case shall the meter touch the ground. Distance between the meter and any obstruction from the front should be a minimum of 36 inches, with the exception of meter protection.

It is preferred not to install a meter set assembly under a deck/porch. However, if no other options are practical, a meter set assembly shall have sufficient access to allow for future maintenance and operation of the meter and operation of the shut-off valve. For such installations, follow the requirements contained in Section 8 below for regulator vent line installation.

**8. SERVICE REGULATOR VENT REQUIREMENTS**

Meter set assemblies with service regulator(s) shall comply with the requirements of this section. This section is not applicable for meter set assemblies supplied from low pressure pipelines or those without service regulator(s).





Distribution Operations

Gas Standard

|                               |  |  |
|-------------------------------|--|--|
| Effective Date:<br>06/01/2016 | <b>Meter Set Assembly Location and<br/>Installation Requirements</b> | Standard Number:<br><b>GS 3020.035</b> |
| Supersedes:<br>N/A            |  | Page 4 of 12                           |

Service regulator vents and relief vents shall terminate outdoors where gas from the vent can escape freely into the atmosphere and away from any opening(s) into a building.

Consideration should be given as to the location of the service regulator and/or relief device to avoid sources of ignition and the possibility of vent terminal freeze-ups. Regulator vent skirts or a vent line extending the vent terminal away from the potential source of moisture should be considered if the potential for vent terminal blockage due to freeze-up is evident.

The regulator and/or relief device vent; vent line, if so equipped; screen; and cap, if present; shall be properly sized, installed, and free of blockage, restrictions or valves, with no external leakage.

Consideration should be given for protection of regulator or relief vents that are located remote from the meter set assembly. Refer to guidance in GS 3020.040 "Meter Set Assembly Protection Residential and Small Commercial."

### 8.1 Aboveground Vent Lines

When a regulator and/or relief device is located inside a building, each regulator and/or relief device shall have a separate metallic relief vent line vented to the outdoors so in the event gas is discharged, it will not create a hazard. Under no circumstance shall the relief vent lines of separate regulators and/or relief devices be manifolded.

If tubing is used for the relief vent line, it shall be metallic and one size larger than the relief opening. In no case shall corrugated tubing be used as a regulator relief vent line.

Relief vent lines shall be as short as possible, and when in excess of ten (10) feet in length or contain more than two (2) elbows, shall be increased one nominal pipe size for each additional ten (10) feet of length. Each elbow in the vent line will contribute approximately three (3) feet in effective length, including the termination elbow.

Service regulators installed outdoors of a building requiring a relief vent line, may be equipped with a PVC vent line conforming to UL 651, schedule 40 or schedule 80 rigid PVC conduit, secured with PVC compatible joining cement/adhesive. Under no circumstance shall the relief vent line be combined with another regulator relief vent line. The same sizing guidance provided above applies.

### 8.2 Belowground Vent Lines

That portion of the regulator vent line that is exposed shall be installed in accordance with the requirements set forth in Section 8.1 of this standard. Under no circumstance shall the relief vent lines of separate regulators and/or relief devices be manifolded.

When no other alternatives exist and it becomes necessary to install a portion of the regulator vent line underground, that portion of the belowground vent line shall be constructed of:



**Distribution Operations**

**Gas Standard**

|                               |  |  |
|-------------------------------|--|--|
| Effective Date:<br>06/01/2016 | <b>Meter Set Assembly Location and<br/>Installation Requirements</b> | Standard Number:<br><b>GS 3020.035</b> |
| Supersedes:<br>N/A            |  | Page 5 of 12                           |

- a. Steel pipe in accordance with the requirements in the 3020 Series of the Gas Standards and protected against corrosion in reference to the 1400 series of the Gas Standards, or
- b. Polyethylene pipe installed in accordance with the 3020 Series of the Gas Standards.

Relief vent lines shall be as short as possible, and when in excess of ten (10) feet in length or contain more than two (2) elbows (including the termination elbow), shall be increased one nominal pipe size for each additional ten (10) feet of length. Each elbow in the vent line will contribute approximately three (3) feet in effective length. All elbows and fittings shall be welded by a qualified welder in accordance with the applicable Company Welding Manual.

Record the location of belowground vent lines within the sketch area on Form GS 3020.012-1 "Service Line Record" in accordance with GS 3020.012 "Service Line Records."

**8.3 Service Regulator Vent Terminal Requirements**

NOTE: All measurements shall be taken from the service regulator vent terminal (relief opening) (see Exhibits A and B).

Except as noted below, the vent terminal:

- a. Shall be installed outdoors above grade, at a minimum height of 12 inches above grade.
- b. In flood-prone areas (refer to Columbia Gas Emergency Manual Form 6.14), a minimum height in excess of 12 inches may be required to prevent the entry of water into the vent terminal.
- c. Shall be installed to protect it from the entry of insects by a screen or an approved vent cap, and be installed so as to prevent the entry of rainwater.
- d. Shall be located not less than three (3) feet radially and not directly below any rotating electrical equipment (e.g., an air conditioning unit).
- e. Should be installed with a minimum of three (3) feet radial separation from an electric meter, electric panel, electric outlet, electric pedestal, electrical equipment disconnect, or pad mounted transformer, etc. When it is not possible to install the regulator vent terminal with a three (3) foot radial separation, a minimum of one (1) foot radial separation shall be maintained between the regulator vent terminal and any of the electric equipment listed above.
- f. Shall be located three (3) feet radially from, and not below, any first floor opening into a building, such as a door, window(s) (that can be opened) or other gravity air opening(s) into a building (including clothes dryer exhaust terminals, and appliance air intakes).



**Distribution Operations**

**Gas Standard**

|                               |  |  |
|-------------------------------|--|--|
| Effective Date:<br>06/01/2016 | <b>Meter Set Assembly Location and<br/>Installation Requirements</b> | Standard Number:<br><b>GS 3020.035</b> |
| Supersedes:<br>N/A            |  | Page 6 of 12                           |

- g. Shall be located not less than ten (10) feet radially from, and not below any forced air inlet into a building (excluding appliance air intakes).

NOTE: It may be acceptable for reduced clearances from building openings and potential sources of ignition when approved self-operated diaphragm service regulators equipped with over pressure protection and vent limiting devices are installed.

**9. METER ALIGNMENT AND SUPPORT**

Each meter set assembly shall be installed in such a manner as to minimize stress on both the piping and the meter and/or service regulator. A meter set assembly shall be supported by at least one of the following methods:

- a. Wall bracket (see Exhibit C).
- b. Support stakes (see Exhibit D).
- c. Other methods approved by leadership.

NOTE: Corrosion control methods should be considered when supporting a meter set assembly. Refer to GS 1420.050 "Coating Methods for Fabricated Stations and Settings" for guidance on coatings to be used above ground and at the soil-to-air interface for the support structure, as well as the meter set assembly. Refer to GS 1420.530 "Installation of Insulators" for guidance on insulating the setting from the support structure, if necessary.

**10. MOBILE HOME/MANUFACTURED HOME METER SET ASSEMBLY – ADDITIONAL REQUIREMENTS**

- a. The meter set assembly (including service regulator if necessary), shall be rigidly supported at the service riser and at the house line outlet on the mobile/manufactured home (manufactured home). See Exhibit E.
- b. The meter set assembly shall be connected to the mobile/manufactured home gas supply connection by a listed gas supply connector for manufactured homes, not less than ¾ inch I.D. tubing size, with a rated capacity equal to, or greater than the connected Btu/h rating of the connected appliances. The gas supply connection shall not be located beneath an exit door of the manufactured home and the connector end must be located outside of the skirting. See Exhibit E.
- c. The gas pressure serving a manufactured home shall not exceed 14 inches water column.
- d. All manufactured homes utilizing fuel gas for any purpose shall be equipped with a natural gas piping system that is acceptable for LP-gas.



**Distribution Operations**

**Gas Standard**

|                               |  |  |
|-------------------------------|--|--|
| Effective Date:<br>06/01/2016 | <b>Meter Set Assembly Location and<br/>Installation Requirements</b> | Standard Number:<br><b>GS 3020.035</b> |
| Supersedes:<br>N/A            |  | Page 7 of 12                           |

### **11. CHECK METER SETTING FOR INSULATION**

A visual check shall be made to ascertain that an insulator between the house lines and service line is installed. When the service line or gas carrying portion of the riser is metallic, the meter insulator shall be electrically tested with an approved instrument (refer to GS 1430.250 "Verifying Electrical Continuity and Isolation") to ensure that the insulator is working properly. If none exists or the existing one is ineffective, a new insulator shall be installed in accordance with GS 1420.530 "Installation of Insulators."

### **12. PREVENTING ELECTRICAL SHOCK**

Personnel working at a customer's premise need to be aware of potential electrical shock hazards. To reduce the risk of an electric shock, employees shall make contact with the gas piping on both the inlet and outlet side of the meter set assembly with a volt meter, or at a minimum, with a non-contact voltage detector prior to any contact with the meter set assembly. Refer to HS&E Safety Notice, "Electrical Hazard - Electrical Current on a Meter Setting."

If voltage is detected, discontinue work at the site and contact the Integration Center to generate an order for service personnel to further investigate the voltage. Refer to GS 6500.100 "Residential and Small Commercial Meter Requirements" for additional guidance.

### **13. METER AND/OR REGULATOR BURIED ENCLOSURES**

The preference is to install customer meters and/or regulators above ground. However, if the installation of the meter and/or regulator in a buried enclosure is necessary, the installation should be planned in a location outside of anticipated vehicular traffic. If vehicular traffic cannot be avoided, the enclosure that houses a customer meter and/or regulator shall be able to support that traffic. Contact local Field Engineering or Gas Transmission and M&R Design for design assistance if the enclosure cannot be located outside of anticipated vehicular traffic.

### **14. RECORDS**

The meter set assembly location and the location of belowground vent lines shall be recorded on Form GS 3020.012-1 "Service Line Record" in accordance with GS 3020.012 "Service Line Records."

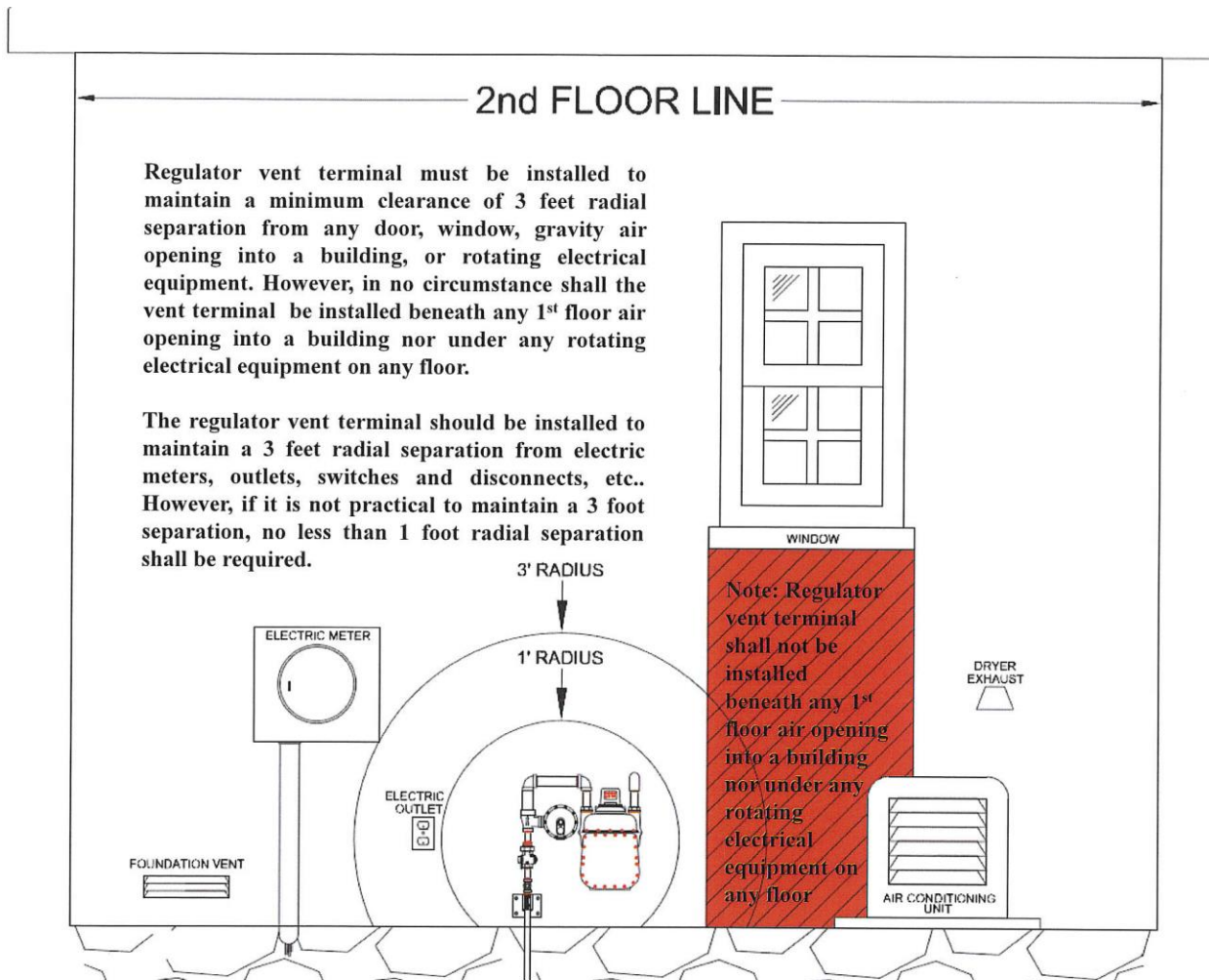


Distribution Operations

Gas Standard

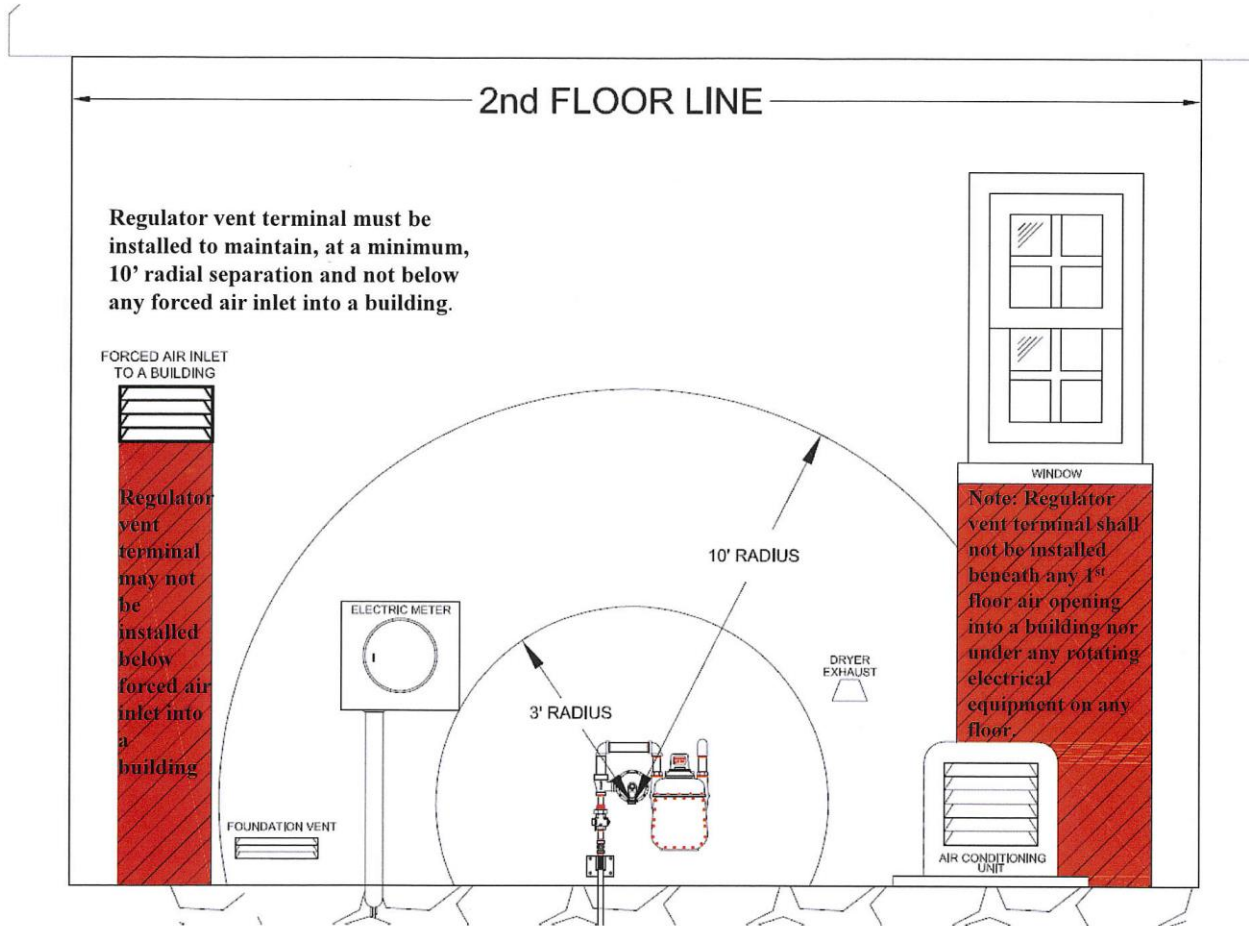
|                               |  |  |
|-------------------------------|--|--|
| Effective Date:<br>06/01/2016 | <b>Meter Set Assembly Location and<br/>Installation Requirements</b> | Standard Number:<br><b>GS 3020.035</b> |
| Supersedes:<br>N/A            |  | Page 8 of 12                           |

**EXHIBIT A**



|                               |  |  |
|-------------------------------|--|--|
| Effective Date:<br>06/01/2016 | <b>Meter Set Assembly Location and<br/>Installation Requirements</b> | Standard Number:<br><b>GS 3020.035</b> |
| Supersedes:<br>N/A            |  | Page 9 of 12                           |

**EXHIBIT B**





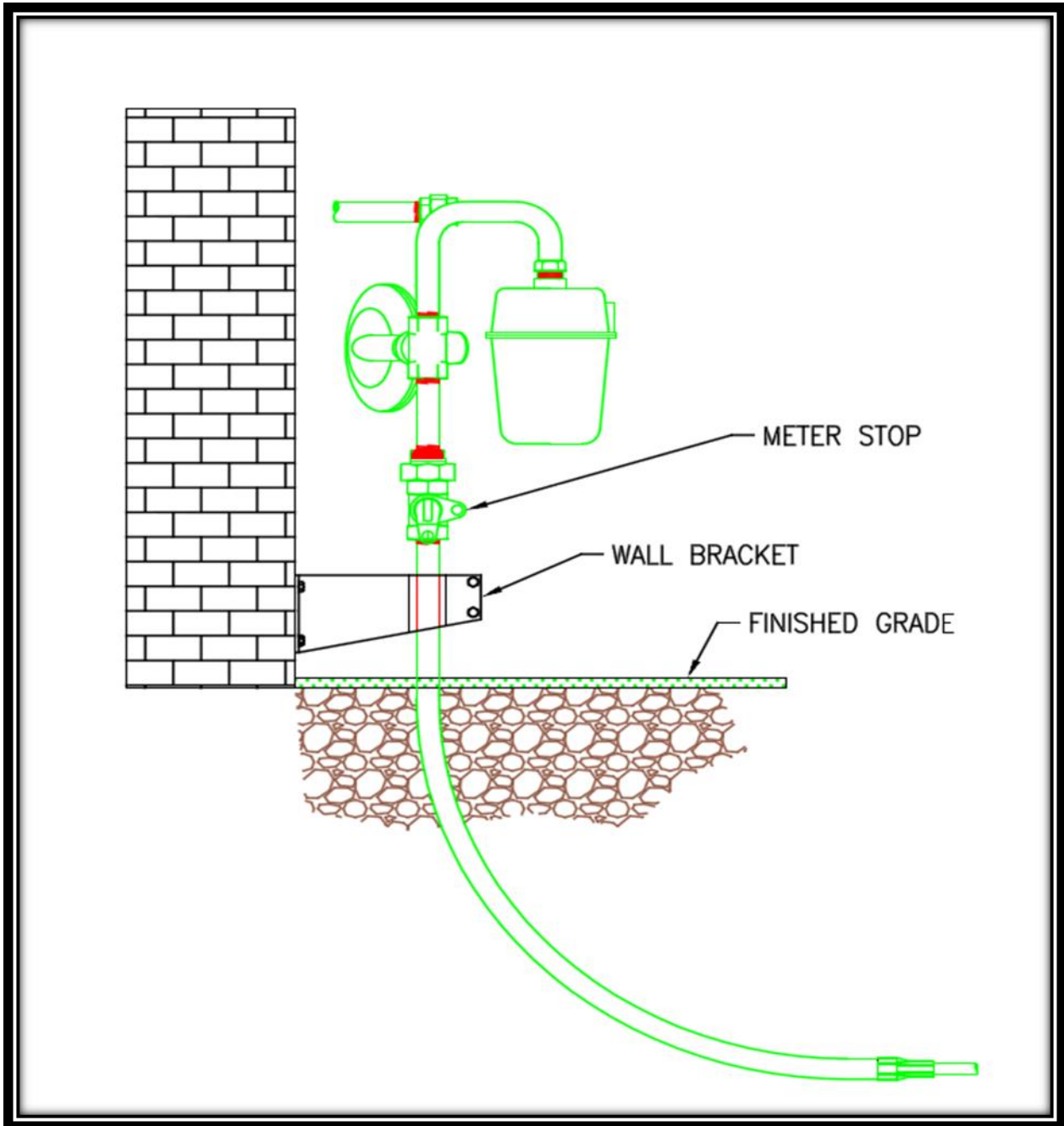


Distribution Operations

Gas Standard

|                               |  |  |
|-------------------------------|--|--|
| Effective Date:<br>06/01/2016 | <b>Meter Set Assembly Location and<br/>Installation Requirements</b> | Standard Number:<br><b>GS 3020.035</b> |
| Supersedes:<br>N/A            |  | Page 10 of 12                          |

EXHIBIT C



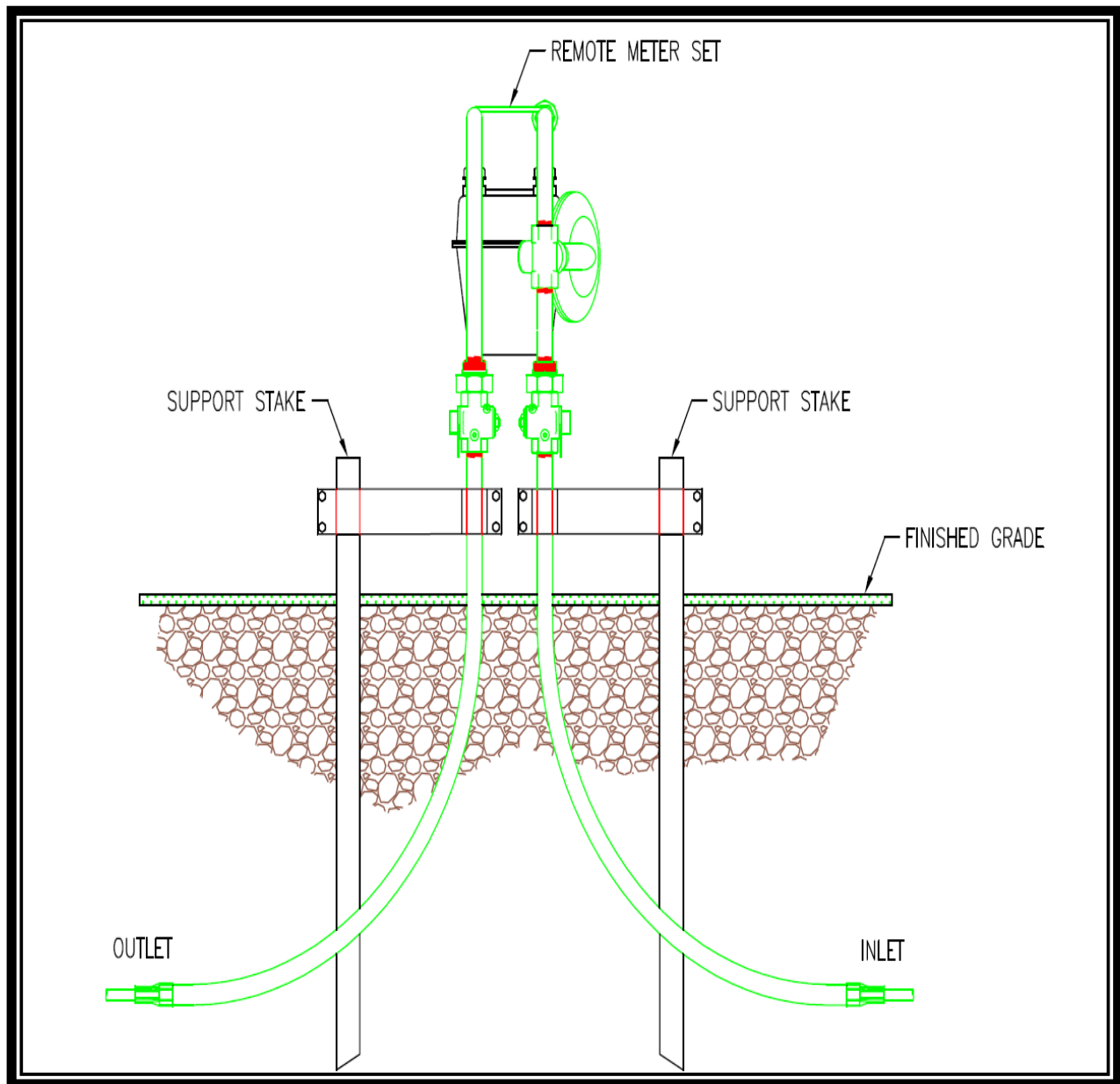


Distribution Operations

Gas Standard

|                               |  |  |
|-------------------------------|--|--|
| Effective Date:<br>06/01/2016 | <b>Meter Set Assembly Location and<br/>Installation Requirements</b> | Standard Number:<br><b>GS 3020.035</b> |
| Supersedes:<br>N/A            |  | Page 11 of 12                          |

**EXHIBIT D**





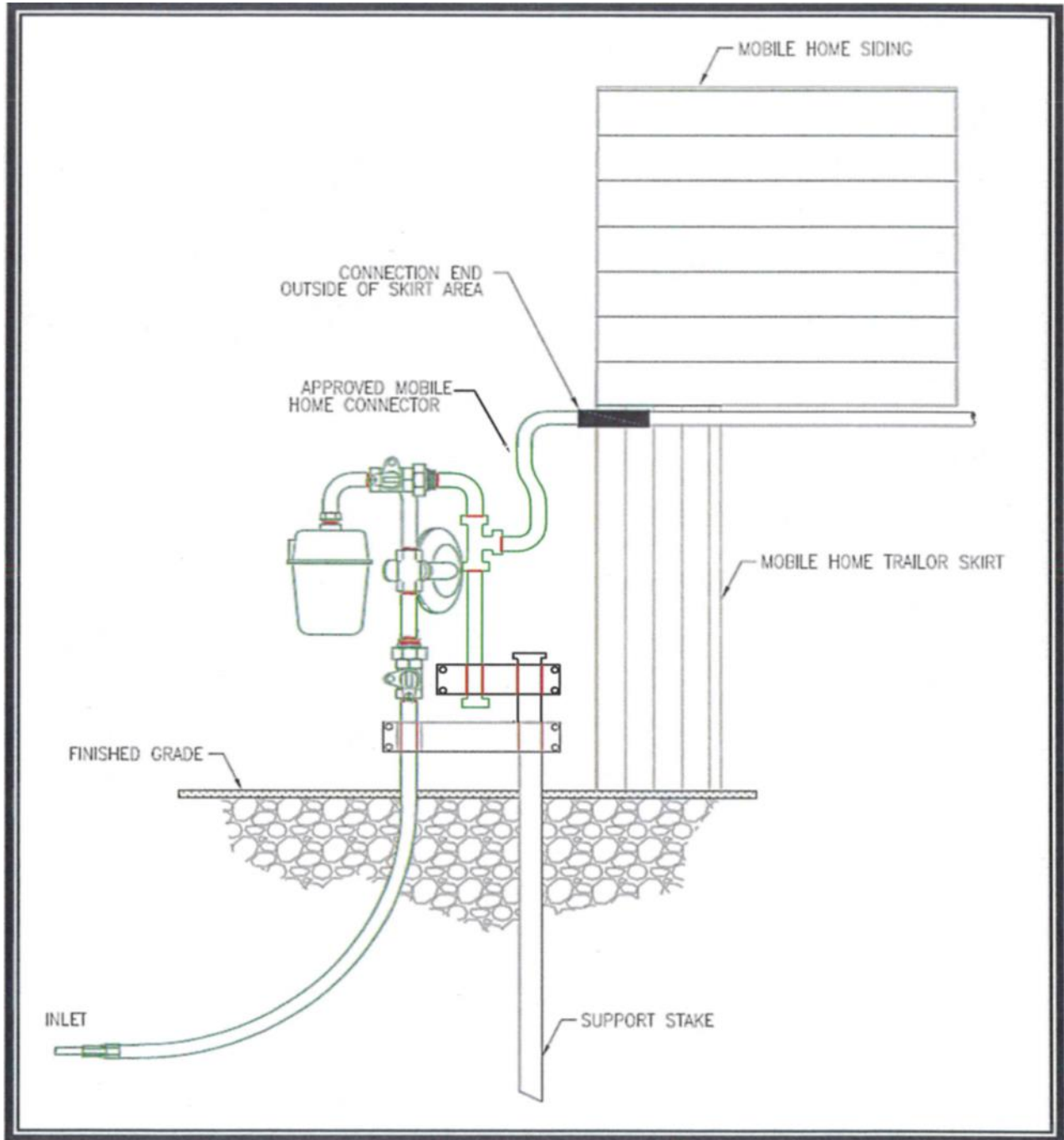


Distribution Operations

Gas Standard

|                               |  |  |
|-------------------------------|--|--|
| Effective Date:<br>06/01/2016 | <b>Meter Set Assembly Location and<br/>Installation Requirements</b> | Standard Number:<br><b>GS 3020.035</b> |
| Supersedes:<br>N/A            |  | Page 12 of 12                          |

EXHIBIT E





**Distribution Operations**

**Gas Standard**

|                               |   |  |
|-------------------------------|---|--|
| Effective Date:<br>06/01/2016 | <b>Meter Set Assembly Protection<br/>Residential and Small Commercial</b> | Standard Number:<br><b>GS 3020.040</b> |
| Supersedes:<br>N/A            |   | Page 1 of 7                            |

Companies Affected:

|                                 |   |   |
|---------------------------------|---|---|
| <input type="checkbox"/> NIPSCO | <input type="checkbox"/> CGV            | <input checked="" type="checkbox"/> CMD |
|                                 | <input checked="" type="checkbox"/> CKY | <input checked="" type="checkbox"/> COH |
|                                 | <input checked="" type="checkbox"/> CMA | <input checked="" type="checkbox"/> CPA |

**REFERENCE** Title 49 CFR 192.353

**1. GENERAL**

Each meter and service regulator, whether inside or outside a building, shall be installed in a readily accessible location and be protected from corrosion and other damage, including, if installed outside a building, vehicular damage that may be reasonably anticipated.

For the purpose of this standard, "readily accessible" means having direct access (e.g., located outdoors), without the need to remove/open any panel, door, or similar obstruction, and with ample space for maintenance or replacement of the meter and/or regulator.

This standard sets forth the requirements for protecting new, replaced, and existing residential and small commercial outside meter set assemblies. For the purpose of this standard, a meter set assembly also includes, where installed, first/second/third cut (as required) service regulators.

For large commercial and industrial meter set assembly and/or service regulator protection requirements, refer to the following applicable gas standards.

|  |   |
|--|---|
| GS 2300.030, "Metering Station Design-8C to 23M Rotary Meters" | GS 2300.040, "Metering Station Design-Turbine Meters" |
|--|---|

For existing meter protection that does not meet the requirements of this gas standard (e.g., no meter protection; inadequate meter protection, such as smaller bollards or inadequate bollard spacing), document and remediate according to the applicable version of GS 1650.020 "Inspection of Risers and Meter Set Assemblies for AOCs" or GS 1650.020(VA) "Inspection Program for Risers and Meter Set Assemblies for AOCs." If no version of GS 1650.020 is applicable, report meter set assembly protection concerns to local leadership.

**2. LOCATION**

For meter set assembly location requirements, refer to GS 3020.035 "Meter Set Assembly Location and Installation Requirements."

When it is not possible to install the meter set assembly as outlined in GS 3020.035 "Meter

*This document is considered CONTROLLED only when viewed electronically on the Company's intranet. Printed or other electronic copies may not be current, and the intranet version should be used to verify.*



**Distribution Operations**

**Gas Standard**

|                               |   |  |
|-------------------------------|---|--|
| Effective Date:<br>06/01/2016 | <b>Meter Set Assembly Protection<br/>Residential and Small Commercial</b> | Standard Number:<br><b>GS 3020.040</b> |
| Supersedes:<br>N/A            |   | Page 2 of 7                            |

Set Assembly Location and Installation Requirements,” protection shall be provided as indicated in Section 3 below.

**3. INSTALLATION OF METER SET ASSEMBLY PROTECTION**

**3.1 Protection from Vehicular Damage - Bollards**

Except for an engineered meter set assembly protection design, bollards shall be installed to protect the meter set assembly as set forth in this section.

See Exhibits A, B, C, D and E for typical bollard application, spacing and installation requirements.

**3.2 Protection from Snow and Ice**

Where a roof overhang does not cover the meter set assembly, consideration shall be given to providing additional protection (e.g., protective meter enclosure) in locations where it is reasonably anticipated that snow or ice accumulation could negatively impact the meter set.

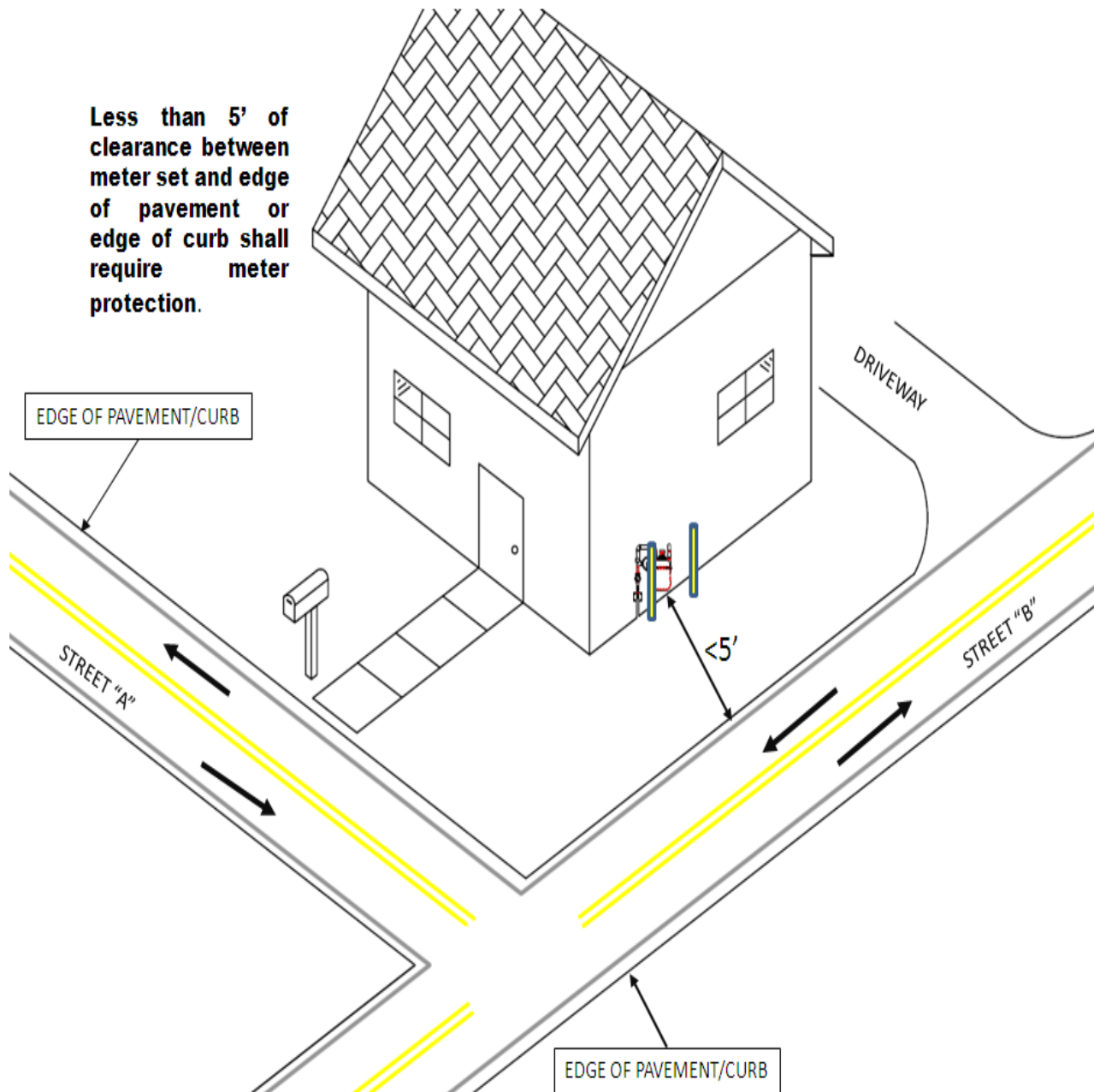


Distribution Operations

Gas Standard

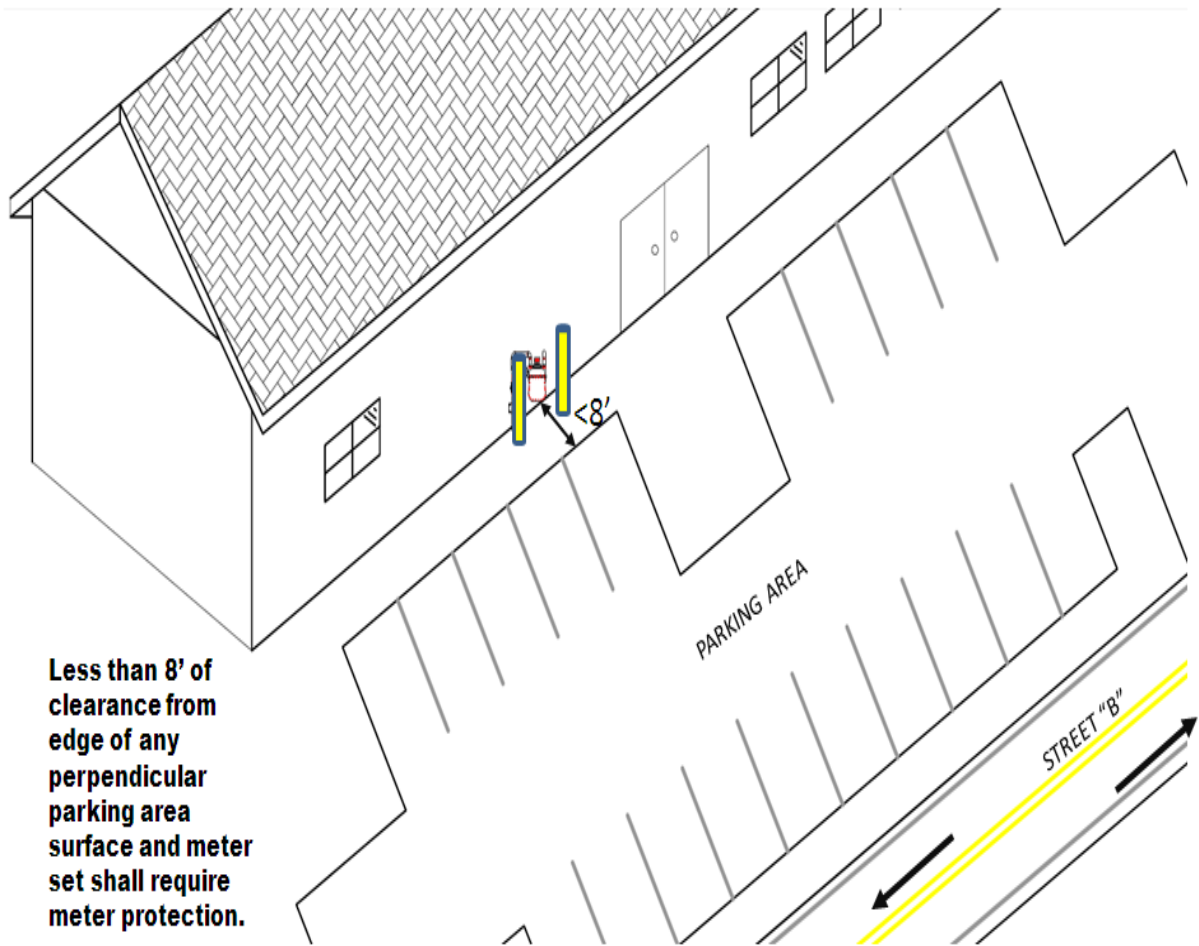
|                               |   |  |
|-------------------------------|---|--|
| Effective Date:<br>06/01/2016 | <b>Meter Set Assembly Protection<br/>Residential and Small Commercial</b> | Standard Number:<br><b>GS 3020.040</b> |
| Supersedes:<br>N/A            |   | Page 3 of 7                            |

**EXHIBIT A**



|                               |   |  |
|-------------------------------|---|--|
| Effective Date:<br>06/01/2016 | <b>Meter Set Assembly Protection<br/>Residential and Small Commercial</b> | Standard Number:<br><b>GS 3020.040</b> |
| Supersedes:<br>N/A            |   | Page 4 of 7                            |

**EXHIBIT B**





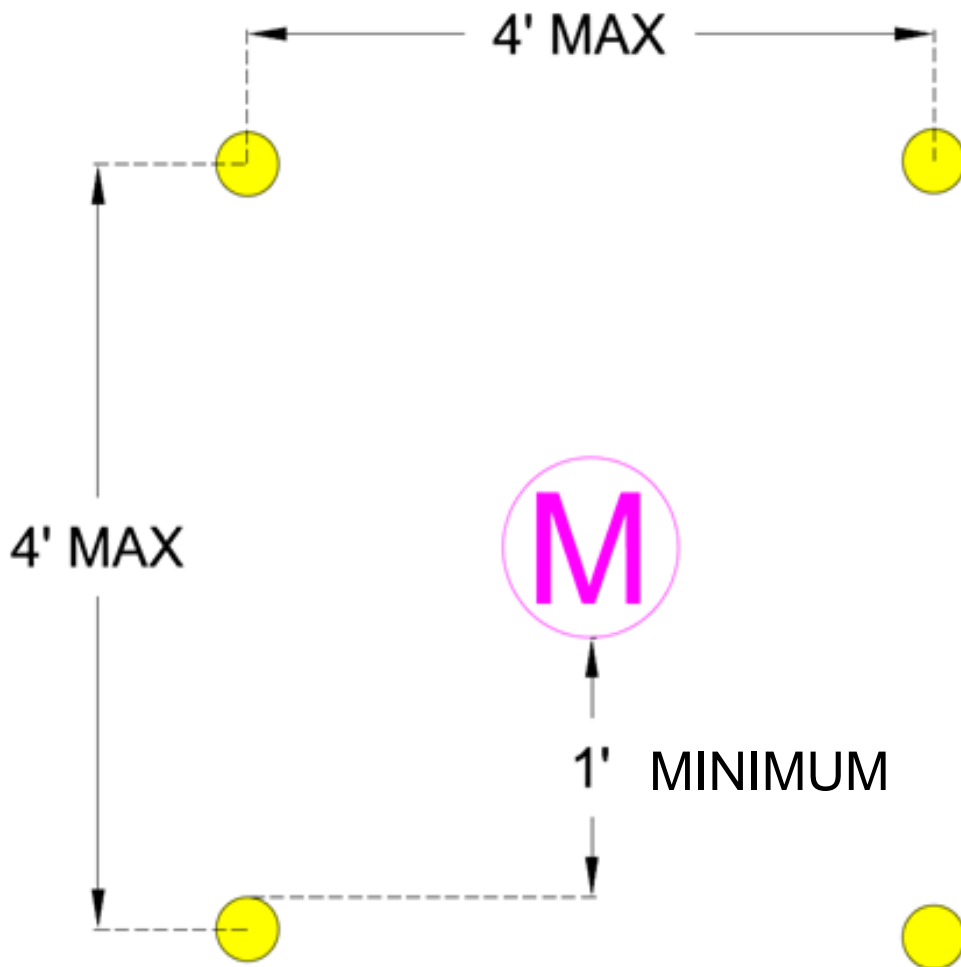
Distribution Operations

Gas Standard

|                               |   |  |
|-------------------------------|---|--|
| Effective Date:<br>06/01/2016 | <b>Meter Set Assembly Protection<br/>Residential and Small Commercial</b> | Standard Number:<br><b>GS 3020.040</b> |
| Supersedes:<br>N/A            |   | Page 5 of 7                            |

EXHIBIT C

Typical Remote Meter Set



NOTE: Actual site location will dictate if bollards need to be spaced closer than 4' apart (e.g., farm field or wooded area where snowmobiles or all-terrain vehicle may be anticipated in the area.)

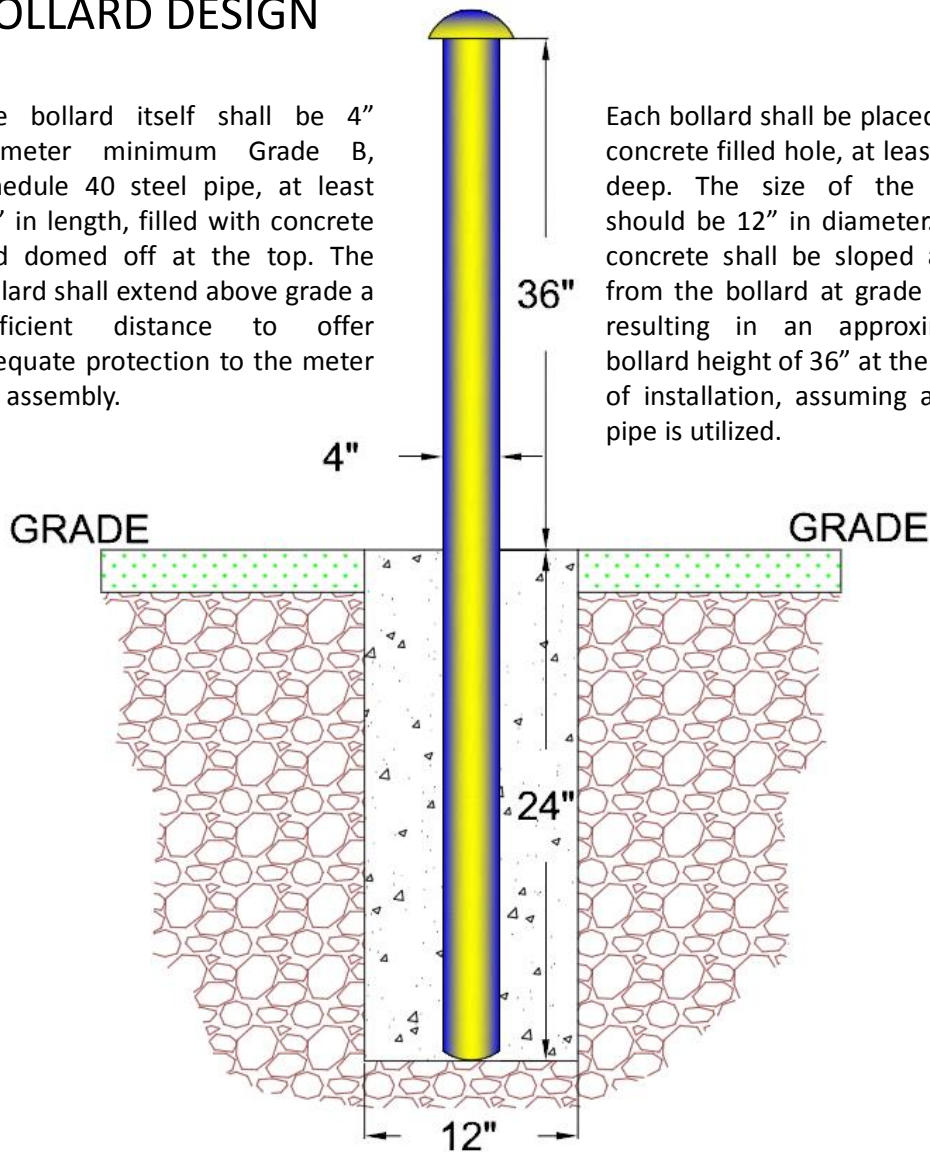
|                               |   |  |
|-------------------------------|---|--|
| Effective Date:<br>06/01/2016 | <b>Meter Set Assembly Protection<br/>Residential and Small Commercial</b> | Standard Number:<br><b>GS 3020.040</b> |
| Supersedes:<br>N/A            |   | Page 6 of 7                            |

**EXHIBIT D**

**STANDARD  
BOLLARD DESIGN**

The bollard itself shall be 4" diameter minimum Grade B, schedule 40 steel pipe, at least 60" in length, filled with concrete and domed off at the top. The bollard shall extend above grade a sufficient distance to offer adequate protection to the meter set assembly.

Each bollard shall be placed in a concrete filled hole, at least 24" deep. The size of the hole should be 12" in diameter. The concrete shall be sloped away from the bollard at grade level resulting in an approximate bollard height of 36" at the time of installation, assuming a 60" pipe is utilized.







**Distribution Operations**

**Gas Standard**

|                               |   |  |
|-------------------------------|---|--|
| Effective Date:<br>06/01/2016 | <b>Meter Set Assembly Protection<br/>Residential and Small Commercial</b> | Standard Number:<br><b>GS 3020.040</b> |
| Supersedes:<br>N/A            |   | Page 7 of 7                            |

**EXHIBIT E**

Bollard Installation Requirements

- Meter settings located less than 5 feet from a roadway, driveway or driving surface edge or road side edge of curb, shall be protected by the installation of at least 2 bollards.
- Meter settings exposed to perpendicular vehicle parking shall have at least 2 bollards installed if the curb edge or edge of driving surface is less than 8 feet from the meter set.
- Maximum spacing of bollards is 4 feet on center.
- If more than 2 bollards are required to protect the meter set assembly, the maximum spacing of the bollards shall not exceed 4 feet.
- Bollards shall be installed no closer than 1 foot from the front of the meter set assembly and shall be positioned to allow adequate room for operation and maintenance activities.

NOTES: A deviation from the standard 4” diameter bollard may be considered in residential, low speed, locations (e.g., where meter protection is required due to close proximity to a driveway). Any deviation from the above requirements shall be approved by local leadership overseeing the installation of the bollards and documented on the Service Line Record (see GS 3020.012 “Installation of Service Lines – Records”).





Distribution Operations

Gas Standard

|                               |   |  |
|-------------------------------|---|--|
| Effective Date:<br>05/14/2014 | <b>Service Line Requirements by<br/>Material Type</b> | Standard Number:<br><b>GS 3020.050</b> |
| Supersedes:<br>11/01/2013     |   | Page 1 of 3                            |

Companies Affected:

|  |   |   |
|--|---|---|
| <input checked="" type="checkbox"/> NIPSCO | <input checked="" type="checkbox"/> CGV | <input checked="" type="checkbox"/> CMD |
|  | <input checked="" type="checkbox"/> CKY | <input checked="" type="checkbox"/> COH |
|  | <input checked="" type="checkbox"/> CMA | <input checked="" type="checkbox"/> CPA |

**REFERENCE** 49 CFR 192.371, 192.373, 192.375, 192.377

## 1. GENERAL

This standard covers the installation requirements specific to various materials. The requirements involve materials of: steel, plastic, cast and ductile iron, and copper.

For general service line installation requirements, refer to the applicable GS 3020.010 "Service Line Installation."

## 2. STEEL SERVICE LINES

Each steel service line to be operated at less than 100 psig must be constructed of pipe designed for a minimum of 100 psig. Steel service lines should be designed at less than 20% of SMYS to avoid it being classified as a **Transmission Line**. Table 1 below provides the design information for commonly installed steel grades and diameters.

For pressures greater than 100 psig, the steel service line must be designed with the appropriate steel grade and wall thickness at the design pressure for its diameter. For additional information, refer to GS 2110.020 "Steel Pipe Design."

Wrinkle bends are prohibited in all steel pipe installations. For additional guidance on making directional changes in steel pipelines, refer to GS 3010.030 "Bends and Elbows."

Screwed fittings shall not be used underground, unless an exception listed below applies.

- a. when connecting to saddles, tap fittings and curb valves,
- b. pipe plugs and caps,
- c. any screwed connection that is integral to an approved fitting.

Anyone joining steel shall be qualified in the discipline being used; i.e. welding or mechanical joining.

*This document is considered CONTROLLED only when viewed electronically on the Company's intranet. Printed or other electronic copies may not be current, and the intranet version should be used to verify.*



|                               |   |  |
|-------------------------------|---|--|
| Effective Date:<br>05/14/2014 | <b>Service Line Requirements by<br/>Material Type</b> | Standard Number:<br><b>GS 3020.050</b> |
| Supersedes:<br>11/01/2013     |   | Page 2 of 3                            |

**Table 1 – Steel Service Line Design (@100 psig)**

| Diameter (nominal) | Steel Grade * | Outside Diameter (inches) | Wall Thickness (inches) | % SMYS | Design P at 20% SMYS (psig) |
|--------------------|---------------|---------------------------|-------------------------|--------|-----------------------------|
| 1/2"               | Grade B       | 0.840                     | 0.109                   | 1.1%   | 1,817                       |
| 3/4"               | Grade B       | 1.050                     | 0.113                   | 1.3%   | 1,507                       |
| 1"                 | Grade B       | 1.315                     | 0.133                   | 1.4%   | 1,416                       |
| 1 1/4"             | Grade B       | 1.660                     | 0.140                   | 1.7%   | 1,181                       |
| 2"                 | Grade X42     | 2.375                     | 0.154                   | 1.8%   | 1,089                       |
| 3"                 | Grade X42     | 3.500                     | 0.188                   | 2.2%   | 902                         |
| 4"                 | Grade X42     | 4.500                     | 0.188                   | 2.8%   | 702                         |

\* API Grade or equivalent

### 3. PLASTIC SERVICE LINES

Only polyethylene plastic shall be installed for new or replacement service lines. Medium-density plastic shall be limited to 60 psig MAOP systems. High-density plastic shall be limited to 99 psig MAOP systems. Any deviation from these requirements shall be appropriately designed and be approved by the Engineering Manager.

Refer to GS 3010.060 or GS 3010.060(IN) "Installation of Plastic Pipe" for general requirements regarding the installation of plastic service lines.

Plastic service lines outside of a building must be installed below ground level, except for one of the following conditions.

1. It is installed as a temporary service according to the requirements of GS 3010.060 or GS 3010.060(IN) "Installation of Plastic Pipe."
2. It is terminated above ground outside of a building where:
  - a. the above ground part of the plastic service line is protected against deterioration and external damage, such as by an anodeless riser; and
  - b. the plastic service line is not used to support external loads.

Plastic service lines inside of a building must be protected against external damage. The plastic pipe may terminate aboveground in buildings, including in basements, by a wall head adapter, where the plastic is inserted through an approved casing.

The most common method of providing protection from external damage to a plastic service line that is above ground or within a building is to completely enclose it in a metal pipe



**Distribution Operations**

**Gas Standard**

|                               |   |  |
|-------------------------------|---|--|
| Effective Date:<br>05/14/2014 | <b>Service Line Requirements by<br/>Material Type</b> | Standard Number:<br><b>GS 3020.050</b> |
| Supersedes:<br>11/01/2013     |   | Page 3 of 3                            |

(casing) of sufficient strength. The metal pipe should have adequate protection against corrosion for its environment, and should extend a minimum of 6 inches below grade for outside installations.

Joints made in plastic service lines, either by fusion or mechanical fittings, shall be made by a qualified person.

**4. CAST IRON AND DUCTILE IRON SERVICE LINES**

Cast iron or ductile iron shall not be installed for new or replacement service lines.

**5. COPPER SERVICE LINES**

Copper shall not be installed for new or replacement service lines.

**6. RECORDS**

The type of service line material shall be indicated in the Company's records and retained for the life of the service line, according to the applicable GS 3020.010 "Installation of Service Lines."



**Gas Standard**

Distribution Operations

|                               |                                     |  |
|-------------------------------|-------------------------------------|--|
| Effective Date:<br>03/01/2010 | <b>New Service Lines Not in Use</b> | Standard Number:<br><b>GS 3020.090</b> |
| Supersedes:<br>N/A            |                                     | Page 1 of 1                            |

Companies Affected:

|   |   |   |
|---|---|---|
| <input checked="" type="checkbox"/> NIPSCO<br>Effective: 09/01/2012 | <input checked="" type="checkbox"/> CGV | <input checked="" type="checkbox"/> CMD |
|   | <input checked="" type="checkbox"/> CKY | <input checked="" type="checkbox"/> COH |
|   | <input checked="" type="checkbox"/> CMA | <input checked="" type="checkbox"/> CPA |

**REFERENCE** 49 CFR 192.379

**1. GENERAL**

Each service line that is not placed in service upon completion of installation must comply with one of the following until the customer is supplied with gas.

- a. A valve shall be closed to prevent the flow of gas to the customer and must have a locking device or other means designed to prevent the opening of the valve by persons other than those authorized by the Company.
- b. A mechanical device or fitting that will prevent the flow of gas must be installed in the service line or in the meter assembly.
- c. The customer's piping must be physically disconnected from the gas supply and the open pipe ends sealed.

**2. RECORDS**

The status of the service line shall be indicated in the Company's records or database. Upon establishing service to the customer, the status shall be updated accordingly.

*This document is considered CONTROLLED only when viewed electronically on the Company's intranet. Printed or other electronic copies may not be current, and the intranet version should be used to verify.*



**Distribution Operations**

**Gas Standard**

|                               |   |  |
|-------------------------------|---|--|
| Effective Date:<br>01/01/2016 | <b>Installation of Excess Flow Valves</b> | Standard Number:<br><b>GS 3020.100</b> |
| Supersedes:<br>01/01/2015     |   | Page 1 of 18                           |

Companies Affected:

|  |   |   |
|--|---|---|
| <input checked="" type="checkbox"/> NIPSCO | <input checked="" type="checkbox"/> CGV | <input checked="" type="checkbox"/> CMD |
|  | <input checked="" type="checkbox"/> CKY | <input checked="" type="checkbox"/> COH |
|  | <input type="checkbox"/> CMA            | <input checked="" type="checkbox"/> CPA |

**REFERENCE** 49 CFR 192.381, 192.383

**1. GENERAL**

This standard covers the installation of excess flow valves (EFVs) in service lines. An EFV is a cartridge valve inside the pipe that immediately closes (“trips”) when the flow exceeds its designed limit at a certain pressure. Its intent is to stop the flow (with negligible bleed-by on certain models) when a line ruptures or is damaged, normally severed by an excavator, creating a very high flow rate. A small amount of leakage, such as due to corrosion, is normally much less than the EFV tripping limit, so it will not protect against these leaks.

The bleed-by feature of a closed EFV will allow a small amount of gas to pass through, acting as a warning and allowing for resetting after repairs have been completed. This is the standard type used by the Company.

A properly-sized EFV will have a trip limit less than the capacity of the service line and greater than the maximum load on the line. This will ensure the EFV will trip when the service line is severed, but not trip for the maximum demand of the connected equipment.

Excess flow valves are available for medium density plastic, high density plastic and steel services lines. Standard EFV model and service line size combinations have been determined to meet most load and service line installation conditions and are available from stock. Manufacturers can supply EFVs pre-installed in the outlet of a service tee or in a short stick of pipe for field installation. Refer to material standard VAL 0260, “Excess Flow Valves – UMAC” for approved EFV manufacturers, sizes and stock codes that are pre-installed in a short stick of pipe.

**2. EXCESS FLOW VALVE INSTALLATION**

The excess flow valve shall be installed as close to the service tap as practical. This will provide protection for the greatest amount of the service line. See Exhibits A and B. Follow the manufacturer’s instructions for EFV installation.

**2.1 Installation Criteria**

An EFV shall be installed on single-family residential, multi-unit residential and non-residential service lines:

*This document is considered CONTROLLED only when viewed electronically on the Company's intranet. Printed or other electronic copies may not be current, and the intranet version should be used to verify.*

|                               |   |  |
|-------------------------------|---|--|
| Effective Date:<br>01/01/2016 | <b>Installation of Excess Flow Valves</b> | Standard Number:<br><b>GS 3020.100</b> |
| Supersedes:<br>01/01/2015     |   | Page 2 of 18                           |

- a. that are newly installed or replaced;

NOTE: For the purpose of this gas standard, a “replaced service line” means a gas service line where the fitting that connects the service line to the main is replaced or the piping connected to this fitting is replaced.

- b. that are supplied by a main or transmission line that operates continuously throughout the year at a pressure not less than 10 psi gauge;
- c. that are not connected to a gas supply with known contaminants that could interfere with the operation of the EFV, and
- d. for which an EFV meeting the performance standards in Section 2.1.1 is commercially available.

### 2.1.1 EFV Performance Standards

EFVs for required installations must be manufactured and tested by the manufacturer according to an industry specification, or the manufacturer’s written specification, to ensure that each valve will:

- a. function properly up to the maximum operating pressure at which the valve is rated;
- b. function properly at all temperatures reasonably expected in the operating environment of the service line;
- c. at 10 psi (69 kPa) gage:
  - i. close at, or not more than 50 percent above, the rated closure flow rate specified by the manufacturer; and
  - ii. upon closure, reduce gas flow for an excess flow valve designed to allow pressure to equalize across the valve, to no more than 5 percent of the manufacturer’s specified closure flow rate, up to a maximum of 20 cubic feet per hour (0.57 cubic meters per hour); and
- d. not close when the pressure is less than the manufacturer’s minimum specified operating pressure and the flow rate is below the manufacturer’s minimum specified closure flow rate.

### 2.2 Required Installations

An EFV shall be installed on all 2 inch and smaller service lines that meet the requirements in Section 2.1. An exception may be granted to this requirement by an



Distribution Operations

Gas Standard

|                               |   |  |
|-------------------------------|---|--|
| Effective Date:<br>01/01/2016 | <b>Installation of Excess Flow Valves</b> | Standard Number:<br><b>GS 3020.100</b> |
| Supersedes:<br>01/01/2015     |   | Page 3 of 18                           |

engineering manager. The reason for the exception must be documented on the service line order. For each installation the total demand and installation conditions must be reviewed to select the proper EFV model. See Section 3 for EFV sizing guidelines.

### 2.2.1 Service Disconnections/Reconnections

An EFV shall be installed when an existing service line is being replaced. An EFV shall also be installed when a service line is disconnected and then reconnected at the main.

### 2.3 Planned Uprates

When service lines are replaced or installed on a pressure system operating at less than 10 psig and it is planned to be uprated to greater than 10 psig, EFVs can be installed before the uprate. It should be recognized that they may not activate if outside of their functioning parameters.

An important consideration also is the pressure drop through the EFV until the system is uprated. This is a particular concern on low pressure systems. The drop may limit available pressure to serve the customer, especially during the higher flow needs of winter heating. Consideration should be given to:

- a. the system's operating pressure,
- b. the load on the service line, and
- c. the length of time until the uprate.

Field Engineering should be consulted to determine the feasibility of the EFV installation. Also, refer to Gas Standards' Informational Memo IM-08-01 for additional guidance.

## 3. EFV SIZING

A properly-sized EFV must trip when the flow is higher than the customer's load and less than full flow of a service line exhausting to atmosphere. Select the proper EFV model based on the following.

- a. The EFV rated trip limit at 10 psig must be greater than the customer's load (or meter size). See Section 3.2 for EFV trip flow requirements.
- b. The maximum trip limit must be less than the flow of a severed service line. Follow the guidelines in Section 3.1 for maximum service length to choose the proper EFV model for the given service line.



**Distribution Operations**

**Gas Standard**

|                               |   |  |
|-------------------------------|---|--|
| Effective Date:<br>01/01/2016 | <b>Installation of Excess Flow Valves</b> | Standard Number:<br><b>GS 3020.100</b> |
| Supersedes:<br>01/01/2015     |   | Page 4 of 18                           |

**3.1 Maximum Service Length**

There is a maximum length of a service for the installed EFV to function properly. Due to the pressure drop through the length of the service, the maximum flow rate decreases as the length increases. Therefore, a service line can be a certain length so that the maximum flow through it is less than the tripping limit of the EFV. This length is mainly critical only for service sizes less than 1", such as 1/2" CTS or 3/4" IPS, and at lower operating pressures, such as, 10 to 15 psig. The maximum service length protected for some common EFV models and sizes at various inlet pressures are shown in Table 1a. The same information for high pressure applications, such as, a high pressure service off of a transmission pipeline is shown in Table 1b. Refer to the manufacturer's literature for other models and pressures.

If the service line length is at or greater than the lengths shown in Table 1a or 1b for its pipe size and the EFV model, the service size must be increased so it will have greater capacity than the EFV to ensure that it trips, even though the smaller service would have met the customer's load demand.





**Gas Standard**

|                               |   |  |
|-------------------------------|---|--|
| Effective Date:<br>01/01/2016 | <b>Installation of Excess Flow Valves</b> | Standard Number:<br><b>GS 3020.100</b> |
| Supersedes:<br>01/01/2015     |   | Page 5 of 18                           |

**Table 1a - Maximum PE Service Lengths for Excess Flow Valves (ft.)**

| Inlet Pressure (psig) | Series 300 | Series 350 | Series 550 |          | Series 700 |          | Series 1100 |        | Series 1800 |            | Series 2600 |        | Series 5500 | Series 10,000 |        |        |       |       |        |       |       |
|-----------------------|------------|------------|------------|----------|------------|----------|-------------|--------|-------------|------------|-------------|--------|-------------|---------------|--------|--------|-------|-------|--------|-------|-------|
|                       | 1/2" CTS   | 3/4" IPS   | 1/2" CTS   | 3/4" IPS | 1/2" CTS   | 3/4" IPS | 1" CTS      | 1" IPS | 1-1/4" CTS  | 1-1/4" IPS | 1" CTS      | 1" IPS | 1-1/4" CTS  | 1-1/4" IPS    | 2" IPS | 2" IPS |       |       |        |       |       |
| 10                    | 145        | 3,131      | 140        | 3,037    | 69         | 1,497    | 2,105       | 2,091  | 2,655       | 6,287      | 258         | 527    | 669         | 1,584         | 8,667  | 127    | 329   | 779   | 4,260  | 1332  | 667   |
| 15                    | 219        | 4,741      | 234        | 5,061    | 119        | 2,579    | 3,174       | 2,996  | 3,804       | 9,008      | 410         | 837    | 1,063       | 2,517         | 13,768 | 272    | 705   | 1,671 | 9,140  | 2,262 | 1,102 |
| 20                    | 280        | 6,061      | 327        | 7,064    | 162        | 3,508    | 4,100       | 4,042  | 5,133       | 12,155     | 542         | 1,107  | 1,405       | 3,327         | 18,201 | 383    | 993   | 2,351 | 12,863 | 3,149 | 1,554 |
| 30                    | 406        | 8,783      | 486        | 10,514   | 248        | 5,354    | 5,831       | 5,653  | 7,179       | 16,997     | 859         | 1,754  | 2,227       | 5,274         | 28,852 | 570    | 1,477 | 3,497 | 19,129 | 5,266 | 2,318 |
| 40                    | 545        | 11,971     | 629        | 13,603   | 337        | 7,296    | 7,709       | 7,625  | 9,683       | 22,926     | 1,161       | 2,371  | 3,011       | 7,129         | 38,996 | 786    | 2,038 | 4,825 | 26,396 | 7,067 | 3,015 |
| 50                    | 677        | 14,642     | 796        | 17,215   | 422        | 9,131    | 9,931       | 9,004  | 11,434      | 27,072     | 1,445       | 2,951  | 3,747       | 8,873         | 48,537 | 989    | 2,565 | 6,072 | 33,219 | 8,722 | 3,865 |

**NOTES:**

- For plastic pipe shown:
 

|                         |                           |
|-------------------------|---------------------------|
| 1/2" CTS is 0.090" wall | 1-1/4" CTS is 0.121" wall |
| 3/4" IPS is SDR-11      | 1-1/4" IPS is SDR 11      |
| 1" CTS is 0.099" wall   |                           |
| 1" IPS is SDR-11        |                           |
- Maximum service lengths for 1" CTS (0.101") PE are nearly the same as 1" CTS (0.099"), so these lengths can be used.
- Steel service lines have similar wall thicknesses to the PE IPS listed in each size, so the lengths shown can be applied.

|                               |   |  |
|-------------------------------|---|--|
| Effective Date:<br>01/01/2016 | <b>Installation of Excess Flow Valves</b> | Standard Number:<br><b>GS 3020.100</b> |
| Supersedes:<br>01/01/2015     |   | Page 6 of 18                           |

**Table 1b - Maximum Service Lengths for Excess Flow Valves for High Pressure Applications (ft.)**

| Inlet Pressure (psig) | Series 300   | Series 700 | Series 1100 | Series 1800 | Series 2600 |
|-----------------------|--------------|------------|-------------|-------------|-------------|
|                       | 1" Pipe Size |            |             |             |             |
| 60                    | 50,354       | 21,517     | 10,584      | 3,335       | 2,322       |
| 100                   | 83,525       | 36,453     | 17,306      | 5,738       | 3,927       |
| 200                   | 213,683      | 91,385     | 38,849      | 13,132      | 9,147       |
| 300                   | 321,422      | 147,135    | 57,329      | 19,511      | 13,675      |
| 400                   | 458,864      | 199,225    | 76,411      | 26,096      | 18,348      |
| 500                   | 615,439      | 246,766    | 96,981      | 33,192      | 23,382      |

**3.2 EFV Trip Flows**

Excess flow valves must be given a trip (label) rating by the manufacturer, and are required to trip at no more than 50% over it. Figure 1 is a copy of a typical trip flow chart provided by one manufacturer for a Series 1800 flow valve that shows its trip flow range at various inlet pressures.

Table 2a provides the manufacturer's trip rate and the maximum at which it is allowed to trip at various inlet pressures. Table 2b provides the same information for high pressure applications, such as, steel services off of a transmission pipeline.

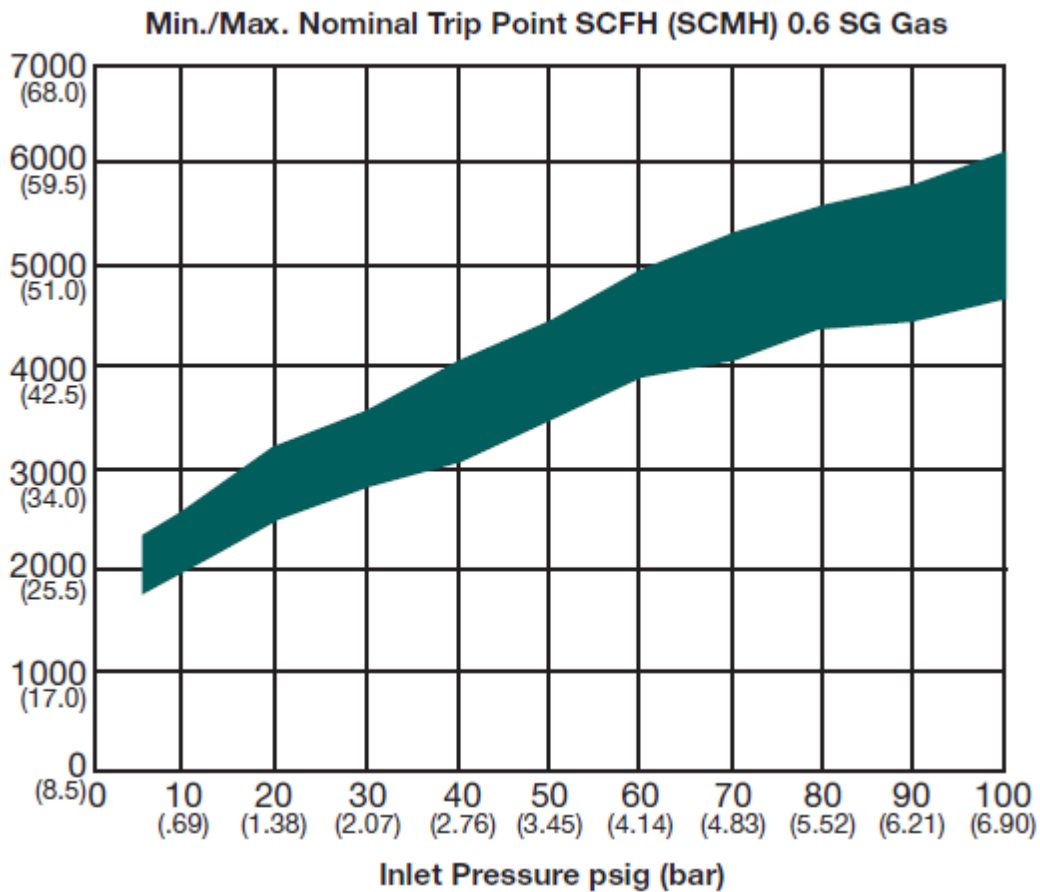
For services with an existing EFV installed where the load will be increased the trip flow and protected length of the EFV needs to be reviewed. The excess flow valve may need to be replaced with a different model that has a higher trip flow. However, the existing EFV may still be adequate after consideration is given to the minimum system pressure if known.



Distribution Operations

Gas Standard

|                               |   |  |
|-------------------------------|---|--|
| Effective Date:<br>01/01/2016 | <b>Installation of Excess Flow Valves</b> | Standard Number:<br><b>GS 3020.100</b> |
| Supersedes:<br>01/01/2015     |   | Page 7 of 18                           |



**Figure 1 – Trip Flow Range for Series 1800 Excess Flow Valve**



**Distribution Operations**

**Gas Standard**

|                               |   |  |
|-------------------------------|---|--|
| Effective Date:<br>01/01/2016 | <b>Installation of Excess Flow Valves</b> | Standard Number:<br><b>GS 3020.100</b> |
| Supersedes:<br>01/01/2015     |   | Page 8 of 18                           |

Table 2a - Excess Flow Valve Trip Ranges (CFH, 0.6 SG gas)

| Inlet P<br>(psig) | Series 300 |       | Series 350 |      | Series 550 |       | Series 700 |       | Series 1100 |       | Series 1800 |       | Series 2600 |       |
|-------------------|------------|-------|------------|------|------------|-------|------------|-------|-------------|-------|-------------|-------|-------------|-------|
|                   | Rating     | Max.  | Rating     | Max. | Rating     | Max.  | Rating     | Max.  | Rating      | Max.  | Rating      | Max.  | Rating      | Max.  |
| 10                | 450        | 675   | 400        | 600  | 550        | 825   | 700        | 1,050 | 1,100       | 1,650 | 2,000       | 3,000 | 2,600       | 3,900 |
| 15                | 490        | 735   | 430        | 645  | 600        | 900   | 760        | 1,140 | 1,230       | 1,845 | 2,250       | 3,375 | 2,700       | 4,050 |
| 20                | 540        | 810   | 460        | 690  | 660        | 990   | 830        | 1,245 | 1,310       | 1,965 | 2,500       | 3,750 | 3,000       | 4,500 |
| 30                | 620        | 930   | 530        | 795  | 760        | 1,140 | 960        | 1,440 | 1,530       | 2,295 | 2,800       | 4,200 | 3,600       | 5,400 |
| 40                | 680        | 1,020 | 600        | 900  | 840        | 1,260 | 1,060      | 1,590 | 1,670       | 2,505 | 3,100       | 4,650 | 4,000       | 6,000 |
| 50                | 740        | 1,110 | 650        | 975  | 920        | 1,380 | 1,200      | 1,800 | 1,870       | 2,805 | 3,400       | 5,100 | 4,400       | 6,600 |

| Inlet P<br>(psig) | Series 5500 |        | Series 10,000 |        |
|-------------------|-------------|--------|---------------|--------|
|                   | Rating      | Max.   | Rating        | Max.   |
| 10                | 5,500       | 8,250  | 10,000        | 15,000 |
| 15                | 6,200       | 9,300  | 10,500        | 15,750 |
| 20                | 6,800       | 10,200 | 11,000        | 16,500 |
| 30                | 7,500       | 11,250 | 12,500        | 18,750 |
| 40                | 8,400       | 12,600 | 14,000        | 21,000 |
| 50                | 9,300       | 13,950 | 15,000        | 22,500 |



**Distribution Operations**

**Gas Standard**

|                               |   |  |
|-------------------------------|---|--|
| Effective Date:<br>01/01/2016 | <b>Installation of Excess Flow Valves</b> | Standard Number:<br><b>GS 3020.100</b> |
| Supersedes:<br>01/01/2015     |   | Page 9 of 18                           |

Table 2b - Excess Flow Valve Trip Ranges (CFH, 0.6 SG gas) High Pressure Application

| Inlet Pressure (psig) | Series 300 |       | Series 700 |       | Series 1100 |       | Series 1800 |        | Series 2600 |        |
|-----------------------|------------|-------|------------|-------|-------------|-------|-------------|--------|-------------|--------|
|                       | Rating     | Max.  | Rating     | Max.  | Rating      | Max.  | Rating      | Max.   | Rating      | Max.   |
| 60                    | 800        | 1,200 | 1,300      | 1,950 | 2,030       | 3,045 | 3,800       | 5,700  | 4,900       | 7,350  |
| 100                   | 1,000      | 1,500 | 1,600      | 2,400 | 2,550       | 3,835 | 4,700       | 7,050  | 6,200       | 9,300  |
| 200                   | 1,210      | 1,815 | 1,960      | 2,940 | 3,329       | 4,993 | 6,135       | 9,202  | 8,093       | 12,139 |
| 300                   | 1,490      | 2,235 | 2,320      | 3,480 | 4,142       | 6,213 | 7,635       | 11,452 | 10,072      | 15,108 |
| 400                   | 1,670      | 2,505 | 2,680      | 4,020 | 4,829       | 7,243 | 8,900       | 13,350 | 11,740      | 17,610 |
| 500                   | 1,810      | 2,727 | 3,040      | 4,560 | 5,401       | 8,101 | 9,955       | 14,932 | 13,132      | 19,698 |

**3.3 Multi-Unit Residential**

The EFV must be sized for all customers on the service line. A simple way to determine the EFV model is to choose the one with a trip flow rating that is greater than the sum of the meters' capacities. For instance, a duplex house with two domestic (Class 250) meters will need an EFV with a trip flow rating greater than 500 CFH. This will assure that the EFV will not trip with both loads at their maximum. While the meter-capacity sizing is a conservative guideline, services to larger numbers of smaller units, such as a four-unit apartment, could have meters with excess capacity so that the total connected load will probably be less than the sum of the meters' capacity.

It should be noted that activation of an EFV installed on a service line to a multi-unit dwelling will require re-lighting all customer in the dwelling. The EFV activation could be as intended when the service line is severed, but it could also be accidental if a serviceworker turns a meter on too quickly. In this case, all other in-service customers on the service line would immediately have to be turned off and then re-lit after the EFV resets.

See Exhibit C for additional guidance.

**3.4 Non-Residential**

Many non-residential customers have the same service and meter setting as a single-family residential customer. An EFV would be installed on those service lines in the



|                               |   |  |
|-------------------------------|---|--|
| Effective Date:<br>01/01/2016 | <b>Installation of Excess Flow Valves</b> | Standard Number:<br><b>GS 3020.100</b> |
| Supersedes:<br>01/01/2015     |   | Page 10 of 18                          |

same manner.

Some non-residential customers are also in multi-unit buildings, such as a shopping plaza, and should be treated similar to the multi-unit residential situation.

A consideration for non-residential buildings is changing use of the building. When the service is installed, the use may only require a domestic meter and have an adequately sized EFV. A future change of use, such as converting to a restaurant, bakery, dry cleaners, or laundrette, may require a larger meter without a change to the service line. The larger load may then be greater than the EFV capacity, and it would have to be replaced.

See Exhibit C for additional guidance.

### **3.5 Determining Meter Capacity**

The tables in Exhibit C provide the recommended meter capacities by K&S number or meter code to use for sizing an excess flow valve. The meter capacities in the tables are based on a 2" w.c. differential across the meter so the larger capacity of the meter is considered in the sizing process. Using this meter capacity to size the EFV for up to 2 psig delivery pressures will help minimize the need to change an EFV later due to a capacity increase.

For delivery pressures above 2 psig consult engineering for EFV sizing. For higher delivery pressures other factors need to be considered, such as, the compressibility factor.

For delivery pressures of 5 or 10 psig a compressibility factor of 1.3 and 1.6 respectively would apply. For example a 3M rotary meter delivering gas at 5 or 10 psig would have a capacity of 3900 and 4800 CFH respectively. This calculated capacity should be used to determine the proper size of EFV to avoid unintended closures.

## **4. RECORDS**

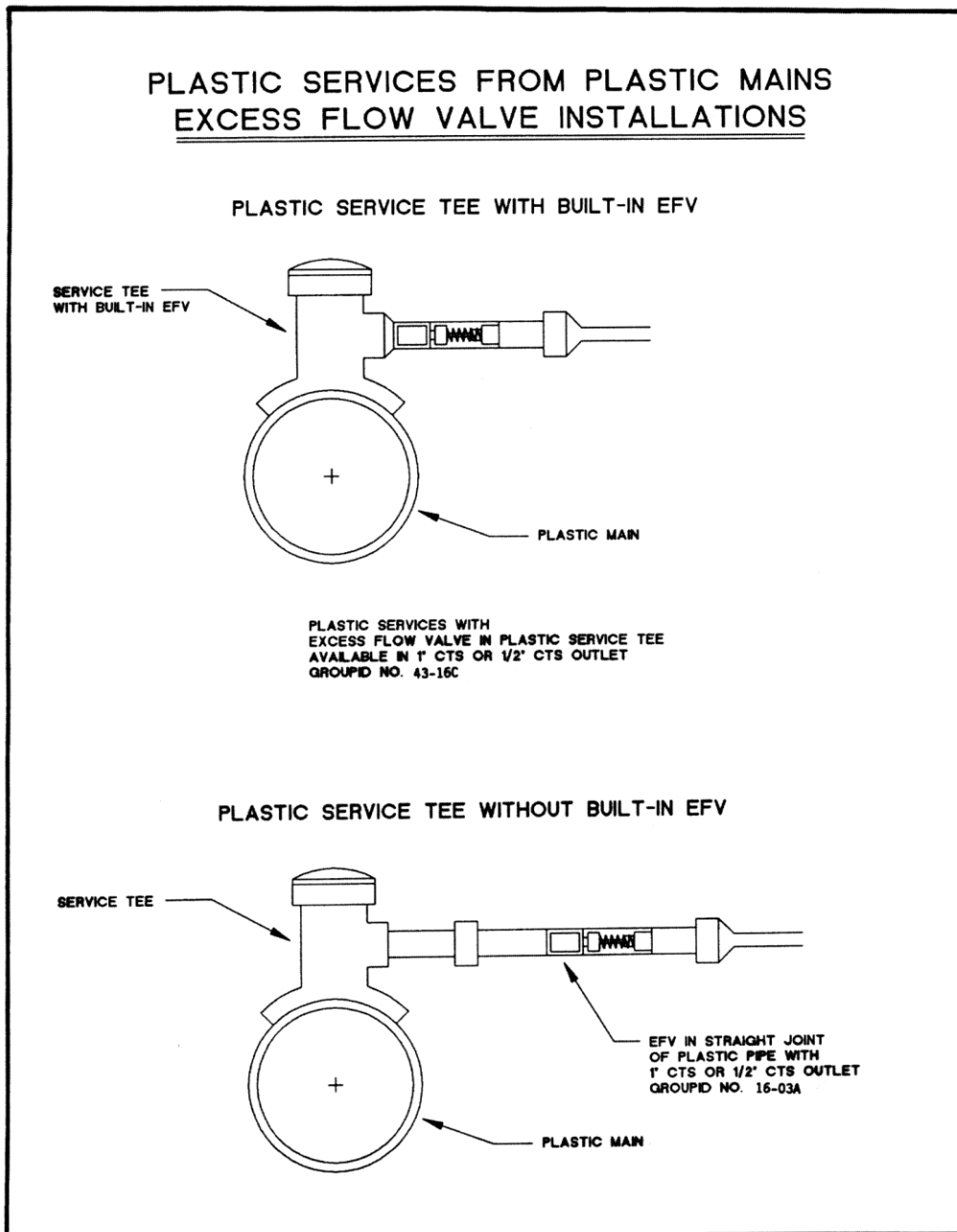
All records used by the Company, such as the hardcopy service line order and/or applicable computer database, shall be updated for all service lines containing an excess flow valve to indicate its presence.

The manufacturer's or Company-supplied tag shall be installed on the meter setting to indicate that an excess flow valve is installed.

|                               |   |  |
|-------------------------------|---|--|
| Effective Date:<br>01/01/2016 | <b>Installation of Excess Flow Valves</b> | Standard Number:<br><b>GS 3020.100</b> |
| Supersedes:<br>01/01/2015     |   | Page 11 of 18                          |

**EXHIBIT A**

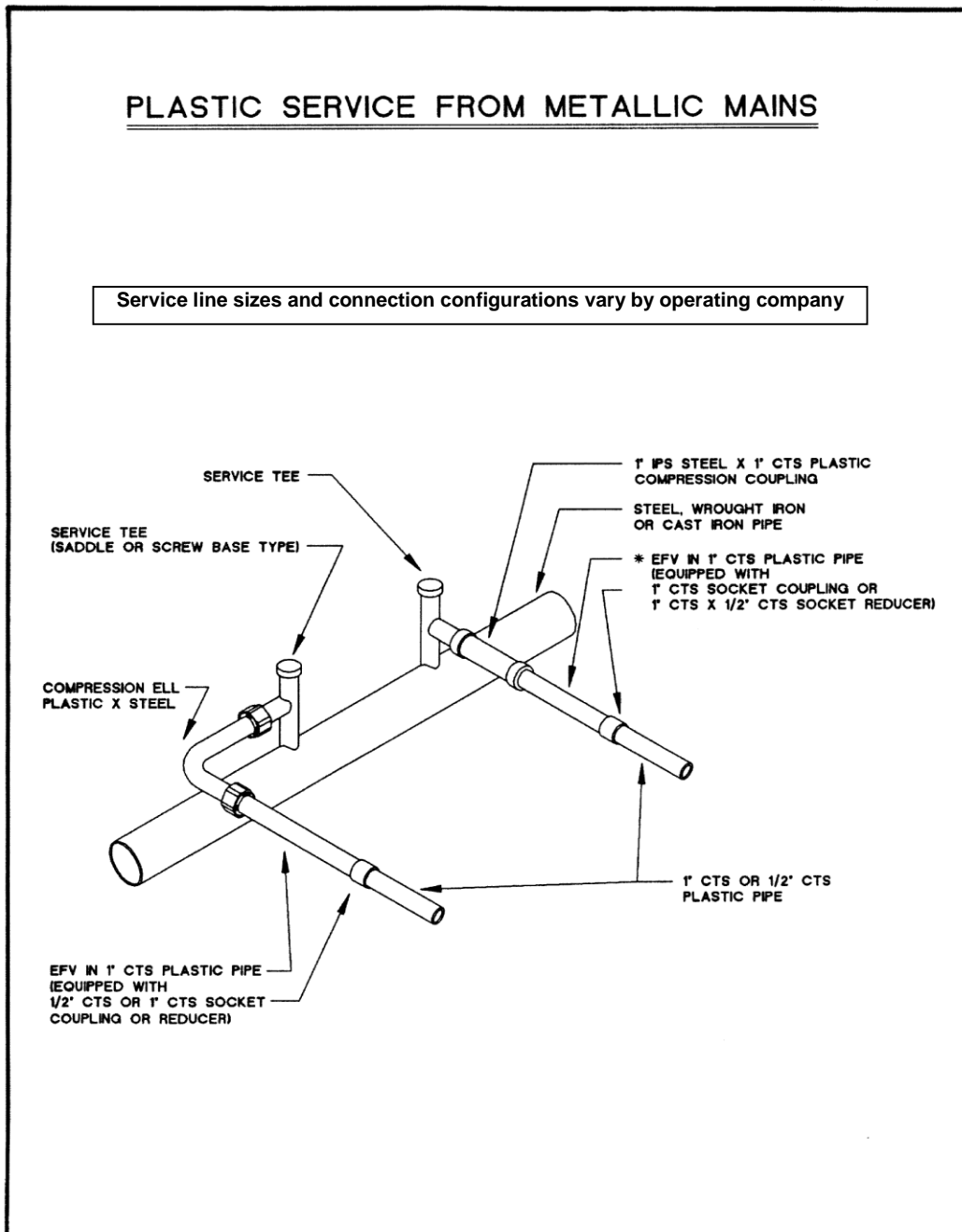
**Plastic Service Line Connections to Plastic Mains**



|                               |   |  |
|-------------------------------|---|--|
| Effective Date:<br>01/01/2016 | <b>Installation of Excess Flow Valves</b> | Standard Number:<br><b>GS 3020.100</b> |
| Supersedes:<br>01/01/2015     |   | Page 12 of 18                          |

**EXHIBIT B**

**Plastic Service Line Connections to Metallic Mains**







**Distribution Operations**

**Gas Standard**

|                               |   |  |
|-------------------------------|---|--|
| Effective Date:<br>01/01/2016 | <b>Installation of Excess Flow Valves</b> | Standard Number:<br><b>GS 3020.100</b> |
| Supersedes:<br>01/01/2015     |   | Page 13 of 18                          |

**EXHIBIT C  
(1 OF 6)**

Follow the guidance on page 2 of this Exhibit to determine if the correct size of excess flow valve is available for installation on a service line serving a large volume residential or commercial customer with a single or multiple meters. The following general conditions should also be noted.

- a. The minimum operating pressure of the attached main is 10 psig or higher.
- b. EFV's may be installed on services on mains operating at less than 10 psig if an up rate of the system is planned and engineering is consulted for guidance.
- c. The entire service line is 2" IPS size or smaller.
- d. Meter type is diaphragm and rotary, no turbine meters allowed.
- e. For services with meter delivery pressures above 2 psig consult with engineering for EFV sizing. The capacity of the meter after applying a pressure factor may be higher than that of an available EFV and one would not be installed. See Section 3.5.

Excess flow valves used by the Company have a bleed-by feature that allows a small amount of gas to pass through a closed valve acting as a warning and allowing for resetting once repairs are completed. Time to reset an excess flow valve may be excessive on a longer service line, particularly if the pipe size is 1-1/4" or larger. For services smaller than 1-1/4" and up to 100 feet in length allow at least 5 minutes to reset and 8 to 15 minutes for services up to 200 feet in length. For 2" services up to 100 feet in length as much as 30 minutes may be needed to reset the excess flow valve. To reduce reset time a valve can be installed downstream of the EFV or the plastic pipe can be squeezed-off. Once the EFV is reset the valve or squeezer can be opened slowly to pack the remainder of the service line.

Because there is no industry standard on EFV sizes and trip rates, the guidance provided in this Exhibit is based on NiSource's current EFV provider. This manufacturer provides for pipe sizes from 1/2 inch to 2 inch that have trip ratings from 400 to 10,000 CFH. See Table 1 of this Exhibit for standard EFV sizes, trip ratings and maximum length of service for each.

Table 2 of this Exhibit provides meter connection capacities listed by K&S (kind and size) number or meter code. The capacities in this table are based on a 2" w.c. pressure drop across the meter and should be used only for sizing excess flow valves.

Note that there are two versions of Table 1 and Table 2 in this Exhibit. One set each for the Columbia Companies (excluding CMA) and NIPSCO.



Distribution Operations

Gas Standard

|                               |   |  |
|-------------------------------|---|--|
| Effective Date:<br>01/01/2016 | <b>Installation of Excess Flow Valves</b> | Standard Number:<br><b>GS 3020.100</b> |
| Supersedes:<br>01/01/2015     |   | Page 14 of 18                          |

**EXHIBIT C  
(2 OF 6)**

**EFV SIZING FOR SERVICES SERVING MULTIPLE METERS AND COMMERCIAL SERVICES OFF MAINS THAT OPERATE AT 10 PSIG OR HIGHER**

\*FOR SERVICES WITH METER DELIVERY PRESSURES GREATER THAN 2 PSIG – CONTACT ENGINEERING\*

SERVICE LINES SERVING A SINGLE METER (Residential LV and Commercial)

1. Determine the meter connection capacity using [Table 2].
2. Using [Table 1] determine the largest capacity EFV for the given pipe size and length.
3. If the meter connection capacity cannot be met for the given pipe size and length use the EFV that satisfies the meter connection capacity.
4. If the meter connection capacity in [Table 2] is shown as N/A or is larger than the maximum EFV capacity (Series) for the pipe size– STOP, do not install an EFV.

SERVICE LINES SERVING MULTIPLE METERS (Residential and Commercial, including manifolds and split services)

1. Using [Table 2] determine the capacity of each meter setting served by the service line.
2. If there is an unused space on a manifold or split use the capacity of the largest meter that can be connected for this space.
3. Total the capacities for ALL meters and unused spaces.
4. Using the [Table 1] determine the largest capacity EFV for the given pipe size and length.
5. If the total meter connection capacity cannot be met for the given pipe size and length use the EFV that satisfies the meter connection capacity.
6. If any meter connection capacity is listed as N/A or the total capacity is larger than the EFV capacity (Series) for the pipe size– STOP, do not install an EFV.

NOTE: When segments of a service line use different pipe sizes, use the smallest pipe size for EFV sizing.



**Gas Standard**

Distribution Operations

|                               |   |  |
|-------------------------------|---|--|
| Effective Date:<br>01/01/2015 | <b>Installation of Excess Flow Valves</b> | Standard Number:<br><b>GS 3020.100</b> |
| Supersedes:<br>07/01/2011     |   | Page 15 of 18                          |

**EXHIBIT C  
(3 OF 6)**

| Pipe Size  | EFV Series (Label Color) | Table 1 (Columbia Only) - Maximum Service Line Length in Feet |
|------------|--------------------------|---|
| 1/2" CTS   | 300                      | 145   |
| 3/4" IPS   | 700                      | 537   |
|            | 300                      | 3131  |
| 1" CTS     | 2600                     | 127   |
|            | 1800                     | 258   |
|            | 1100                     | 1024  |
|            | 700                      | 2105  |
| 1 1/4" IPS | 5500                     | 243   |
|            | 2600                     | 779   |
|            | 1800                     | 1584  |
| 2" IPS     | 10000                    | 667   |
|            | 5500                     | 1332  |
|            | 2600                     | 4260  |



**Gas Standard**

Distribution Operations

|                               |   |  |
|-------------------------------|---|--|
| Effective Date:<br>01/01/2015 | <b>Installation of Excess Flow Valves</b> | Standard Number:<br><b>GS 3020.100</b> |
| Supersedes:<br>07/01/2011     |   | Page 16 of 18                          |

**EXHIBIT C  
(4 OF 6)**

| Pipe Size  | EFV Series (Label Color) | Table 1 (NIPSCO Only) - Maximum Service Line Length in Feet |
|------------|--------------------------|---|
| 1/2" CTS   | 350                      | 140   |
|            | 550                      | 69  |
| 1" CTS     | 2600                     | 127   |
|            | 1800                     | 258   |
|            | 1100                     | 1024  |
|            | 700                      | 2105  |
| 1" IPS     | 1800                     | 527   |
|            | 1100                     | 2091  |
|            | 700                      | 4298  |
| 1 1/4" IPS | 2600                     | 779   |
|            | 1800                     | 1584  |
| 2" IPS     | 10000                    | 667   |
|            | 5500                     | 1332  |
|            | 2600                     | 4260  |



**Gas Standard**

Distribution Operations

|                               |   |  |
|-------------------------------|---|--|
| Effective Date:<br>01/01/2015 | <b>Installation of Excess Flow Valves</b> | Standard Number:<br><b>GS 3020.100</b> |
| Supersedes:<br>07/01/2011     |   | Page 17 of 18                          |

**EXHIBIT C  
(5 of 6)**

**Table 2 - Columbia Meter Connection Capacities (CFH) by Meter K&S (for EFV sizing only)**

| Description        | K&S | CAP  | Description               | K&S | CAP  | Description               | K&S | CAP  | Description                  | K&S | CAP  |
|--------------------|-----|------|---------------------------|-----|------|---------------------------|-----|------|------------------------------|-----|------|
| AL 175             | 602 | 540  | Roots/Dress 1.5M/175      | 690 | 2300 | Sprague 240W/R            | 759 | 540  | Rockwell R175 TC             | 816 | 540  |
| American 5B225     | 604 | 540  | Roots/Dress 3M/175        | 705 | 9000 | Metris 250                | 760 | 540  | Rockwell R200                | 817 | 540  |
| AL 800             | 605 | 2300 | Roots/Dress 5M/175        | 706 | 9000 | Sprague 250               | 761 | 540  | Rockwell R250                | 818 | 540  |
| AT 210             | 606 | 540  | Roots/Dress 7M/175        | 707 | 9000 | Romet 23000175            | 762 | N/A  | Rockwell R310                | 819 | 540  |
| Invalid            | 607 | 540  | Roots/Dress 16M/175       | 708 | N/A  | Metris 250                | 763 | 540  | Rockwell R415                | 820 | 1400 |
| AL250/AC250        | 608 | 540  | Roots/Dress 11M/175       | 709 | N/A  | Schlumberger 250          | 764 | 540  | Rockwell R750                | 821 | 2300 |
| AL 250B            | 609 | 2300 | Roots/Conn 38M125/175     | 711 | N/A  | Schlumberger 400A TC      | 765 | 1400 | Rockwell 800-1600            | 822 | 2300 |
| AL 500B            | 610 | 9000 | Roots/Conn 23M/125        | 712 | N/A  | Schlumberger 800 TC       | 766 | 2300 | Rockwell R275                | 823 | 540  |
| AL 1000            | 611 | 2300 | Roots/Conn 56M/125        | 713 | N/A  | Schlumberger 1000A TC     | 767 | 2300 | Rockwell 3000                | 824 | 9000 |
| AL 800             | 612 | 2300 | Sprague 1A                | 718 | 540  | EMCO/Rockwell 00/150      | 768 | 540  | Rockwell R750                | 821 | 2300 |
| AL 1400            | 613 | 9000 | Roots/Conn 16M/600        | 719 | N/A  | RW Turbo T18/125          | 777 | N/A  | Rockwell 800-1600            | 822 | 2300 |
| AR 250             | 614 | 540  | Metris MB 250             | 731 | 540  | RW Turbo T-18/440         | 778 | N/A  | Rockwell R275                | 823 | 540  |
| AL 5000            | 615 | 9000 | Roots/Dress 1.5M/125      | 733 | 2300 | RW Turbo T-30/125         | 779 | N/A  | Rockwell 3000                | 824 | 9000 |
| AL 425             | 616 | 1400 | Roots/Conn 3M/125         | 734 | 9000 | RW Turbo T-30/1440        | 781 | N/A  | Equimeter 1000               | 825 | 2300 |
| AL 2300            | 617 | 9000 | Roots/Conn 5M/125         | 735 | 9000 | EMCO/Rockwell 2-1/2       | 784 | 1400 | RW 4, 5000 & A5000           | 826 | 9000 |
| AC 630             | 619 | 1400 | Roots/Conn 7M/125         | 736 | 9000 | EMCO/Rockwell 3           | 788 | N/A  | RW Turbo T-30/175            | 827 | N/A  |
| Amer. RPM 1.5M/285 | 621 | 9000 | R/C 10M or 11M/125        | 737 | N/A  | EMCO/Rockwell 4           | 792 | N/A  | Rockwell 10,000              | 828 | 9000 |
| Amer. RPM 3.5M/285 | 623 | 9000 | Sprague 4A & 675          | 738 | 1400 | RW Turbo T-18/720         | 793 | N/A  | Superior AL 175A             | 829 | 540  |
| Amer. RPM 5.5M/285 | 624 | 9000 | Roots/Conn 16M/125        | 739 | N/A  | RW Turbo T-30/720         | 794 | N/A  | Superior AL 250              | 830 | 540  |
| Amer. RPM 7M285    | 625 | 9000 | Roots/Dress 2M175 TQM/B3  | 741 | 2300 | RW Turbo T-140/720        | 795 | N/A  | Superior AL 340              | 831 | 540  |
| Amer. RPM 11M/285  | 626 | N/A  | Roots/Dress 8C175 TQM/B3  | 742 | N/A  | RW Turbo T-60/175         | 797 | N/A  | National 175A                | 833 | 540  |
| Amer. RPM 16M/285  | 627 | N/A  | Roots/Dress 11C175 TQM/B3 | 743 | 2300 | RW Turbo T-18/175         | 798 | N/A  | RW Turbo T-27/175            | 835 | N/A  |
| Ironcase 10B       | 630 | 540  | Roots/Dress 15M175 TQM/B3 | 744 | 2300 | RW Turbo T-140/220        | 799 | N/A  | RW Turbo T-27/720            | 837 | N/A  |
| Ironcase 35B       | 646 | 1400 | Roots/Dress 3M175 TQM/B3  | 745 | N/A  | EMCO/Rockwell 5, A5       | 800 | 9000 | RW Turbo T-57/175            | 841 | N/A  |
| Ironcase 80B       | 654 | 2300 | Sprague 5, 5A 7, 1000     | 746 | 2300 | RW Turbo T-60/1440        | 801 | N/A  | RW Turbo T-57/720            | 842 | N/A  |
| Ironcase 250B      | 658 | 9000 | Roots/Dress 5M175 TQM/B3  | 747 | 9000 | RW Turbo T-60/720         | 807 | N/A  | RW Turbo T-90/175            | 845 | N/A  |
| Ironcase 500B      | 662 | 9000 | Roots/Dress 7M175 TQM/B3  | 748 | 9000 | RW Turbo AAT-60/175       | 808 | N/A  | RW Turbo T-90/720            | 846 | N/A  |
| Romet 16000/175    | 682 | N/A  | Roots/Dress 11M175 TQM/B3 | 749 | N/A  | RW Turbo AAT-60/720       | 809 | N/A  | RW Turbo T-230/220           | 847 | N/A  |
| Romet 1000/125     | 683 | 2300 | Roots/Dress 16M175 TQM/B3 | 750 | N/A  | RW Turbo AAT-18/175       | 810 | N/A  | Lancaster 250 5 dial digital | 869 | 540  |
| Romet 2000/175     | 685 | 9000 | Schlumberger 675A         | 751 | 1400 | RW Turbo AAT-18/720       | 811 | N/A  | Lancaster 240/250            | 870 | 540  |
| Romet 3000/175     | 686 | 9000 | Sprague 175               | 755 | 540  | RW Turbo AAT-30/175       | 812 | N/A  | Roots 3M740 HPC              | 900 | N/A  |
| Romet 5000/175     | 687 | 9000 | Sprague 175W/R            | 756 | 540  | RW Turbo AAT-30/720 or 35 | 813 | N/A  |                              |     |      |
| Romet 7000/175     | 688 | 9000 | Sprague 175R/M            | 757 | 540  | Rockwell R175             | 814 | 540  |                              |     |      |
| Romet 11000/175    | 689 | N/A  | Sprague 240               | 758 | 540  | Rockwell 175-S            | 815 | 540  |                              |     |      |

Note: Meters capacities shown are at a 2" W.C. drop. For meters that use the same meter setting without modification the capacity at a 2" W.C. drop for the largest meter was used for all. For example: a 425 meter has a capacity of 900 cfh and a 630 meter has a capacity of 1300 cfh. Since both could be hung on the same setting the higher capacity, (1300) was used for the 425 meter so that in the event a customer needed additional capacity and that it could be served simply by changing out the meter it would not be necessary to dig up and change the EFV. Only if the meter setting needed physical changes would the EFV possibly need changed.



**Gas Standard**

Distribution Operations

|                               |   |  |
|-------------------------------|---|--|
| Effective Date:<br>01/01/2015 | <b>Installation of Excess Flow Valves</b> | Standard Number:<br><b>GS 3020.100</b> |
| Supersedes:<br>07/01/2011     |   | Page 18 of 18                          |

**EXHIBIT C  
 (6 OF 6)**

**Table 2 (NIPSCO) – Meter Connection Capacities (CFH) by Meter Code  
 (for EFV sizing only)**

| Description | Code | Capacity          | Description | Code | Capacity          |
|-------------|------|-------------------|-------------|------|-------------------|
| AC250       | A3   | 540 <sup>1</sup>  | 1.5M        | QC   | 2800 <sup>4</sup> |
| AL425       | A6   | 1000 <sup>1</sup> | 2M          | QB   | 3700 <sup>4</sup> |
| 400A        | B6   | 1000 <sup>1</sup> | 3M          | QD   | 4300 <sup>4</sup> |
| AC630       | A7   | 1480 <sup>1</sup> | 5M          | QE   | 9000 <sup>4</sup> |
| AL800       | A8   | 2100 <sup>2</sup> | 7M          | QF   | NA                |
| AL3000      | R8   | 5000 <sup>3</sup> | 11M         | QG   | NA                |
| AL5000      | R9   | 8400 <sup>3</sup> | 16M         | QH   | NA                |
| AL10000     | R4   | NA                |             |      |                   |

Notes

- Capacity at 2 PSIG delivery pressure at 2" W.C. drop across meter with pressure factor applied.
- Not used at 2 PSIG delivery pressure at NIPSCO. Capacity shown is at 5 PSIG delivery pressure at 2" W.C. drop across meter with pressure factor applied.
- Not used at 2 PSIG delivery pressure at NIPSCO. Capacity at 10 PSIG delivery pressure at 2" W.C. drop across meter with pressure factor applied.
- Not used at 2 PSIG delivery pressure at NIPSCO. Capacity shown is badged capacity plus 10% with pressure factor for a 10 PSIG delivery pressure applied.



**Distribution Operations**

**Gas Standard**

|                               |  |   |
|-------------------------------|--|---|
| Effective Date:<br>05/31/1996 | <b>Underwater Pipeline Inspections</b> | Standard Number:<br><b>GS 5200.200(CG)</b><br>P&P 665-2 |
| Supersedes:<br>N/A            |  | Page 1 of 3   |

Companies Affected:

|                                     |   |   |
|-------------------------------------|---|---|
| <input type="checkbox"/> NIPSCO     | <input type="checkbox"/> CGV            | <input type="checkbox"/> CMD            |
| <input type="checkbox"/> NIFL       | <input checked="" type="checkbox"/> CKY | <input checked="" type="checkbox"/> COH |
| <input type="checkbox"/> Kokomo Gas | <input type="checkbox"/> CMA            | <input type="checkbox"/> CPA            |

**REFERENCE** Code of Federal Regulations - Title 49 - Part 192 - §§ 192.613 and 192.709

**1. GENERAL REQUIREMENTS**

Underwater pipeline inspections shall be conducted at least once every five (5) calendar years on pipeline crossings of waters where a substantial likelihood of commercial navigation exists and where the pipeline requires weighting to achieve negative buoyancy.

These pipeline crossings shall also be reviewed by means of an on-site inspection annually. The annual on-site review shall consist of a visual inspection of the waterway banks to determine if detrimental erosion has occurred or if the pipeline has become exposed to the extent that it could collect debris.

Following the annual review, a supplemental underwater pipeline inspection should be considered, where appropriate.

A licensed diver may be required to conduct the underwater pipeline inspection. Depending upon the waterway width and depth, the annual review may be conducted from the banks, utilizing a small boat or walking/wading.

It is the responsibility of the District Operations Manager (or equivalent) to ensure that those pipeline crossings which require underwater inspections are identified and the requirements set forth in this procedure are met.

**2. SUPPLEMENTAL INSPECTIONS**

Supplemental underwater inspections should be considered when:

- a. severe flooding is experienced;
- b. evidence of erosion is observed;
- c. operating conditions are such that additional inspections are prudent; or,
- d. the pipeline is or becomes exposed and could collect debris.

*This document is considered CONTROLLED only when viewed electronically on the Company's intranet. Printed or other electronic copies may not be current, and the intranet version should be used to verify.*



**Distribution Operations**

**Gas Standard**

|                               |  |   |
|-------------------------------|--|---|
| Effective Date:<br>05/31/1996 | <b>Underwater Pipeline Inspections</b> | Standard Number:<br><b>GS 5200.200(CG)</b><br>P&P 665-2 |
| Supersedes:<br>N/A            |  | Page 2 of 3   |

**3. SCHEDULING OF INSPECTIONS**

It is suggested that pipeline crossings which require underwater inspections be coordinated on a District or Company-wide basis to take advantage of economy of scale. It is also recommended that WMS Repetitive Tasks be established to schedule and document the underwater pipeline inspections and annual reviews.

**4. INSPECTION PROCEDURE**

**4.1 Pre-Inspection Activities**

The following items shall be addressed prior to conducting pipeline inspections where underwater inspection techniques are required:

- a. Notify the nearest Army Corps of Engineers Office of proposed inspection on navigable waters, where required.
- b. Locate the pipeline where it enters and leaves the water.
- c. Locate any existing boat launching ramps near the crossing.
- d. Research records of previous inspections so that the conditions of the crossing can be evaluated. Note and communicate any unusual conditions previously encountered to the diving personnel, when applicable.
- e. Consider having the diving personnel perform a pipe-to-soil corrosion survey on the pipeline.

Note: Items a, b, c and e listed above may be performed by a contractor.

**4.2 Inspection Information**

When utilized, the divers shall inspect for the following during the inspection, where applicable:

- a. leakage;
- b. exposed piping and its condition, including coating;
- c. debris adjacent to or caught on the pipe;
- d. stability of banks; and
- e. the probability of the pipe being struck by barge or boat traffic.

**5. REMEDIAL ACTION**

The District Operations Manager (or equivalent) or designee shall review the inspection reports and determine if the segment of pipeline is in satisfactory condition. If it is





**Distribution Operations**

**Gas Standard**

|                               |  |   |
|-------------------------------|--|---|
| Effective Date:<br>05/31/1996 | <b>Underwater Pipeline Inspections</b> | Standard Number:<br><b>GS 5200.200(CG)</b><br>P&P 665-2 |
| Supersedes:<br>N/A            |  | Page 3 of 3   |

determined that the segment of pipeline is in an unsatisfactory condition but no immediate hazard exists, a program to recondition or phase out the segment involved shall be initiated.

**6. RECORD KEEPING**

When utilized, contracted divers shall furnish a written report for each crossing indicating the pipeline condition, amount of pipe exposed (if any), the condition of the waterway bottom, etc.

Records for pipeline crossings requiring underwater inspections shall be maintained at a location(s) determined by the District Operations Manager (or equivalent).



**Distribution Operations**

**Gas Standard**

|                               |  |  |
|-------------------------------|--|--|
| Effective Date:<br>11/01/2013 | <b>Removal of Liquids from Pipelines</b> | Standard Number:<br><b>GS 5300.100</b> |
| Supersedes:<br>N/A            |  | Page 1 of 19                           |

Companies Affected:

|                                 |   |   |
|---------------------------------|---|---|
| <input type="checkbox"/> NIPSCO | <input checked="" type="checkbox"/> CGV | <input checked="" type="checkbox"/> CMD |
|                                 | <input checked="" type="checkbox"/> CKY | <input checked="" type="checkbox"/> COH |
|                                 | <input checked="" type="checkbox"/> CMA | <input checked="" type="checkbox"/> CPA |

**REFERENCE** Code of Federal Regulations - Title 40 - Part 761  
Code of Federal Regulations - Title 49 - Part 172

**1. WATER**

Water problems in pipelines are normally associated with flooding. However, localized water problem areas are often identified from customers' complaints of no gas or low pressure. In some instances, water problems may be reported by Company employees who notice abnormal pressure fluctuations.

**1.1 Locating**

Normally water will accumulate in low points of the piping system. Pinpointing the exact location of water pockets may require a series of dew point tests or excavations to establish the location for removal of water. When the source of water is from surface drainage, or ground water, leakage information may be utilized in an attempt to find the point of entry. Surface potential surveys may also assist in locating suspected points of entry.

In relatively level terrain, it may be necessary to make a series of excavations and pipeline taps to determine the exact location of water pockets. Or, as an alternative, a systematic analysis of the dew points along the system can frequently be used to determine not only the water pockets, but also to pinpoint the leakage area.

The latter method can be accomplished by taking test readings at various tap points with a dew point analyzer, hygrometer, or other moisture detecting equipment. The test points are chosen where easy access to the gas can be gained.

When it is determined that pinpointing of a water entry point is desirable and the Operating Center does not have a hygrometer, Field Engineering may be contacted for assistance and equipment.

**1.2 Removal**

Removal of water from a main or service line can be accomplished by:

- a. pumping a drip (Exhibit A)
- b. siphoning low pressure systems (Exhibit B)

*This document is considered CONTROLLED only when viewed electronically on the Company's intranet. Printed or other electronic copies may not be current, and the intranet version should be used to verify.*



**Distribution Operations**

**Gas Standard**

|                               |  |  |
|-------------------------------|--|--|
| Effective Date:<br>11/01/2013 | <b>Removal of Liquids from Pipelines</b> | Standard Number:<br><b>GS 5300.100</b> |
| Supersedes:<br>N/A            |  | Page 2 of 19                           |

- c. purging the main or service (Exhibit C)
- d. tapping the bottom of the pipe
- e. pigging the main (with a soft pig)
- f. isolating sections of a main or a service line and blowing out the water.

Equipment that might cause ignition shall not be used, nor shall open flames or smoking be permitted in area during water removal operations.

**1.3 Disposal**

Water shall be collected and disposed of in accordance with Section 2.8.

Disposal of water used for hydrostatic testing of a pipeline shall be in accordance with GS 1500.010 "Pressure Testing."

**2. HYDROCARBON LIQUIDS**

The supplier of natural gas is required by contract to provide clean, dry gas, free of liquid or solid contaminants. This is usually accomplished by installing scrubbers, filters, siphons, drips and other liquid entrapment and collection devices at or upstream of the point of sale, in which case the supplier will be responsible for their installation, operation, maintenance and disposal of the liquid.

However, on occasion the supplier's facilities may fail or a pressure reduction may cause hydrocarbons in the vapor state to "drop out." Liquids may then appear in distribution facilities such as regulators, meters and piping system low points. It may then be necessary for the Company to install equipment to remove the liquids at additional points in the distribution system.

**2.1 PCB Contaminated Hydrocarbon Liquids**

In some distribution systems low levels of polychlorinated biphenyls (PCBs) have been found in hydrocarbon liquids. Locations where previous tests have been negative may handle collectible quantities as if they were not contaminated until future tests prove otherwise. In distribution systems where liquids have been previously tested positive they should be handled as if they were PCB contaminated until tested as outlined in Section 2.4.

In distribution facilities where liquids have accumulated the liquids shall be collected and representative samples analyzed per Sections 2.3 and 2.4 for the presence of PCBs prior to disposal.

**2.2 Handling**

When working around hydrocarbon liquids, care shall always be exercised because of



**Distribution Operations**

**Gas Standard**

|                               |  |  |
|-------------------------------|--|--|
| Effective Date:<br>11/01/2013 | <b>Removal of Liquids from Pipelines</b> | Standard Number:<br><b>GS 5300.100</b> |
| Supersedes:<br>N/A            |  | Page 3 of 19                           |

their potentially volatile nature. Equipment that might cause ignition shall not be used, nor shall any open flame or smoking be permitted in the area.

Employees shall be instructed to wash their hands and any exposed skin before eating, drinking, smoking or using toilet facilities after handling liquids.

**2.2.1 Non-Contaminated Liquids**

If there is a likelihood of splashing or spilling, eye protection and other protective equipment shall be worn as needed.

**2.2.2 Contaminated Liquids**

In addition to section 2.2.1 employees handling hydrocarbon liquids suspected to be contaminated shall wear impervious disposable gloves.

Locations where tests have indicated the presence of PCB contaminated liquids shall stock at least one two-person disposable protective equipment kit. These protective kits should be used whenever the operation to be performed can result in spraying or otherwise enveloping an employee in the contaminated liquid.

**2.3 Collection**

Depending upon volume, liquids can be temporarily collected in any convenient size metal, glass, or plastic container. Metal, then glass, is preferable over plastic. Once a container has been used to collect liquids contaminated with PCBs, it shall either be disposed of in accordance with Section 2.8.3 of this procedure or identified and used exclusively as a PCB container. All PCB containers must be marked.

**2.4 Sampling and Lab Analysis**

Representative samples shall be taken:

- a. whenever liquids are initially found in a distribution facility that has historically been dry.
- b. when a large volume of liquids, such as a drum full, is removed at one time from a facility.
- c. when storage drums, in which small collections of liquids have been accumulated over a period of time become at least half full.
- d. when required by a disposal transporter. Tests may be required for PCBs, pH, BS&W (bottom sediment and water), flash point and EP toxicity.

The following sampling instructions shall be used, as applicable:



**Distribution Operations**

**Gas Standard**

|                               |  |  |
|-------------------------------|--|--|
| Effective Date:<br>11/01/2013 | <b>Removal of Liquids from Pipelines</b> | Standard Number:<br><b>GS 5300.100</b> |
| Supersedes:<br>N/A            |  | Page 4 of 19                           |

- a. The pipeline facility shall be drained as completely as practical into a collection container so that any subsequent sampling will be representative of the next period of collection.
- b. Let the collection container stand open to atmosphere for at least fifteen (15) minutes to allow any entrapped gas to escape and to permit liquids (such as oils and water) to separate.
- c. If solids are present throughout the liquid, it will be necessary to agitate the contents prior to sampling in order to obtain a representative sample.
- d. Using a disposable pipette, syringe or other sampling device, fill a small glass bottle with at least 1 fl. oz. of sample. The cap of the bottle shall either be teflon lined or aluminum foil used between the cap and the bottle.
- e. To avoid cross contamination of samples the sampling device shall not be reused unless a second sample is taken for quality assurance. Care shall be taken to insure that the outside of the glass bottles and caps are not contaminated.
- f. Tightly secure cap of sample container, seal with tape and then place inside of a plastic zip lock type bag. Place the plastic bag(s) into a second zip lock bag. The zip lock bag shall be packed inside of a cardboard box with shipping material to prevent breakage. Special labeling is not required as long as the amount of liquid per package does not exceed 16 fl. oz.
- g. Contact Health, Safety and Environmental (HSE) for the appropriate testing laboratory address.
- h. Complete Form GS 5300.100-1, "Request for Liquid Sample Analysis," Exhibit D. Send one copy of Form GS 5300.100-1 to the Environmental Compliance Manager

Note: A hydrocarbon liquid shall be considered to be PCB contaminated if laboratory tests indicate presence of PCBs at a detectable level. This may be expressed as "no detectable level" rather than expressly "not contaminated" by laboratory.

**2.5 On Site Storage**

All operating areas shall have an adequate number of sealable 55 gallon drums available to store hydrocarbon liquids that they may accumulate. All drums containing hydrocarbon liquids shall be labeled "FLAMMABLE LIQUIDS."

A container once used for PCB contaminated liquid collection shall not be used for any other purpose unless it has been decontaminated as per Section 2.9 to avoid cross contamination. Such containers shall be labeled.

Containers shall be stored in an outdoor location that will minimize deterioration of the containers and any introduction of rain water. It is suggested that the containers be on an elevated platform, such as a pallet to avoid corrosion.



**Distribution Operations**

**Gas Standard**

|                               |  |  |
|-------------------------------|--|--|
| Effective Date:<br>11/01/2013 | <b>Removal of Liquids from Pipelines</b> | Standard Number:<br><b>GS 5300.100</b> |
| Supersedes:<br>N/A            |  | Page 5 of 19                           |

Note: Since there may be a pressure buildup in a closed container from entrapped gases, caution shall be used when reopening.

**2.6 Spills**

In the event of a hydrocarbon liquid spill, immediate efforts shall be made to contain the spill. If a spill is suspected to contain PCBs the local HSE representative shall be consulted before attempting any cleanup activity.

Additionally any spill of a hazardous or polluting nature shall be reported immediately in accordance with HSE 4400.020(CG) "Environmental Occurrence Reporting."

**2.7 Transportation**

No containers except sample containers shall be carried in the passenger portion of a vehicle. Containers shall be secured and protected while being transported.

PCB contaminated liquids in excess of 10 gallons or any hydrocarbon liquids in excess of 110 gallons shall not be transported in one vehicle at one time.

**2.8 Disposal**

Liquids removed at a facility jointly occupied by the Company and a supplier, regardless of who operates the facility, shall be disposed of by the supplier. Hydrocarbon liquids found in distribution facilities shall be disposed of by the Company.

**2.8.1 Non-Contaminated Liquids**

Non-contaminated liquids may be disposed of through a company that collects used oil.

**2.8.2 Contaminated Liquids**

Contaminated liquids shall be disposed of by transporting to a location designated by HSE for storage and ultimate disposal. Transportation shall be in accordance with Section 2.7.

**2.8.3 Disposable Equipment**

Until associated sample results are known, disposable personal protective clothing, rags, soil and other debris that has come in contact with the liquid shall be collected in sealed plastic bags and placed in a close-able metal container, such as a trash can.

If the sample is determined to be contaminated, the equipment shall be disposed of in the same manner as contaminated liquids.



**Distribution Operations**

**Gas Standard**

|                               |  |  |
|-------------------------------|--|--|
| Effective Date:<br>11/01/2013 | <b>Removal of Liquids from Pipelines</b> | Standard Number:<br><b>GS 5300.100</b> |
| Supersedes:<br>N/A            |  | Page 6 of 19                           |

If the sample is determined to be non-contaminated, the equipment maybe disposed of as ordinary trash.

**2.8.4 Manifests and Certificates**

For contaminated liquids collected in distribution facilities it is necessary to utilize a manifest system to insure proper disposal and provide proof of compliance with environmental regulations. A manifest is a multi-copy document which is supplied and completed by the transporter.

The Operating Center shall send all copies of the manifest and certificates of disposal to the HSE department. A copy of Form GS 5300.100-3, "Pipeline Liquids - Disposal History", Exhibit F, if used, shall also be forwarded.

HSE shall:

- a. conduct investigations for manifest not received within 30 days.
- b. advise appropriate management and regulatory agencies of manifest not received.
- c. maintain all manifests for at least three years.

**2.9 Decontamination**

Containers used to collect PCB contaminated liquids may be re-used. If re-used for other than contaminated liquids they shall be decontaminated by flushing at least three times with kerosene. Each rinse shall use a volume equal to approximately ten percent of the container. The kerosene may be re-used until its PCB concentration exceeds 50 p.p.m. at which time it shall be disposed of as instructed in Section 2.8.2. Empty non-contaminated or decontaminated containers may be disposed of as municipal solid waste.

**3. INSTALLATION OF A DRIP**

If required, drips usually are most effective when installed at the lowest point of the main. A typical drip installation is shown on Exhibit A. Drips are Property Unit Items and as such their installation shall be covered on a Work Order.

**4. INSTALLATION OF A SIPHON**

Siphon fittings are recommended only for temporary installations.

Exhibit B illustrates a typical siphon installation. When new siphons are installed, siphon tubes shall not be left protruding into the main.

Where periodic liquid problems exist or occur, consideration should be given to the installation of a permanent drip.



**Distribution Operations**

**Gas Standard**

|                               |  |  |
|-------------------------------|--|--|
| Effective Date:<br>11/01/2013 | <b>Removal of Liquids from Pipelines</b> | Standard Number:<br><b>GS 5300.100</b> |
| Supersedes:<br>N/A            |  | Page 7 of 19                           |

**5. RECORDS**

Each operating area shall maintain a record of all drip and siphon locations. In addition to location the record may include liquid removal schedule, type liquid removed, and type installation.

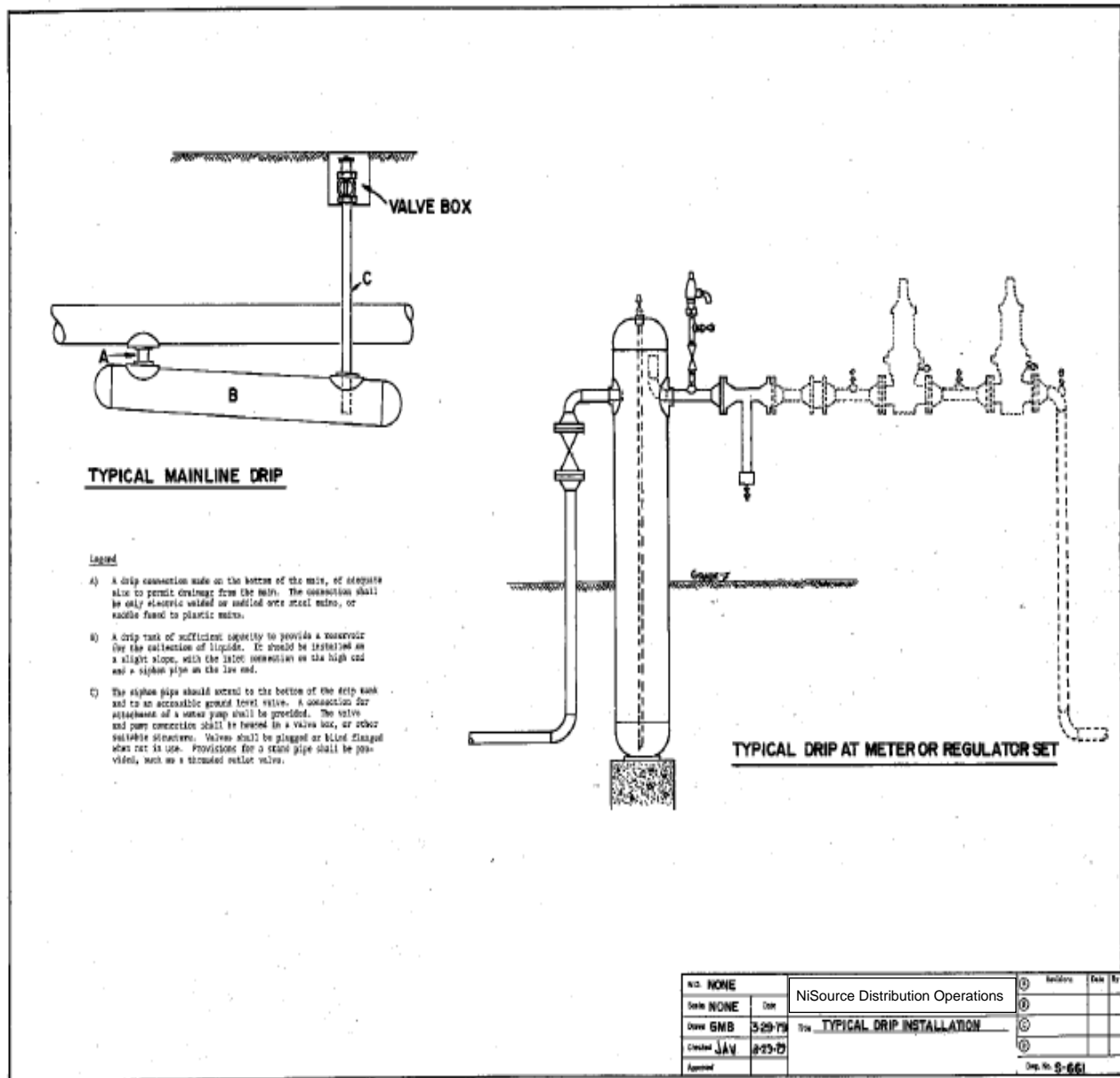
Operating Areas may use Form GS 5300.100-2 "Report of Liquid Found," Exhibit E and Form GS 5300.100-3 "Pipeline Liquids - Disposal History," Exhibit F to provide a detailed record of liquid removal and disposal. If used, Form GS 5300.100-2 would be completed when the liquid was removed from the pipeline facility and Form GS 5300.100-2 would remain with the storage drum, be noted each time liquids are added and upon disposal attached to the manifest to be forwarded to the Environmental Compliance Manager.

Operating Centers requesting an oil or other distillate samples analysis are required to complete GS 5300.100-1, "Request for Liquid Sample Analysis," Exhibit D, maintain a numbering control and file for returned copies.



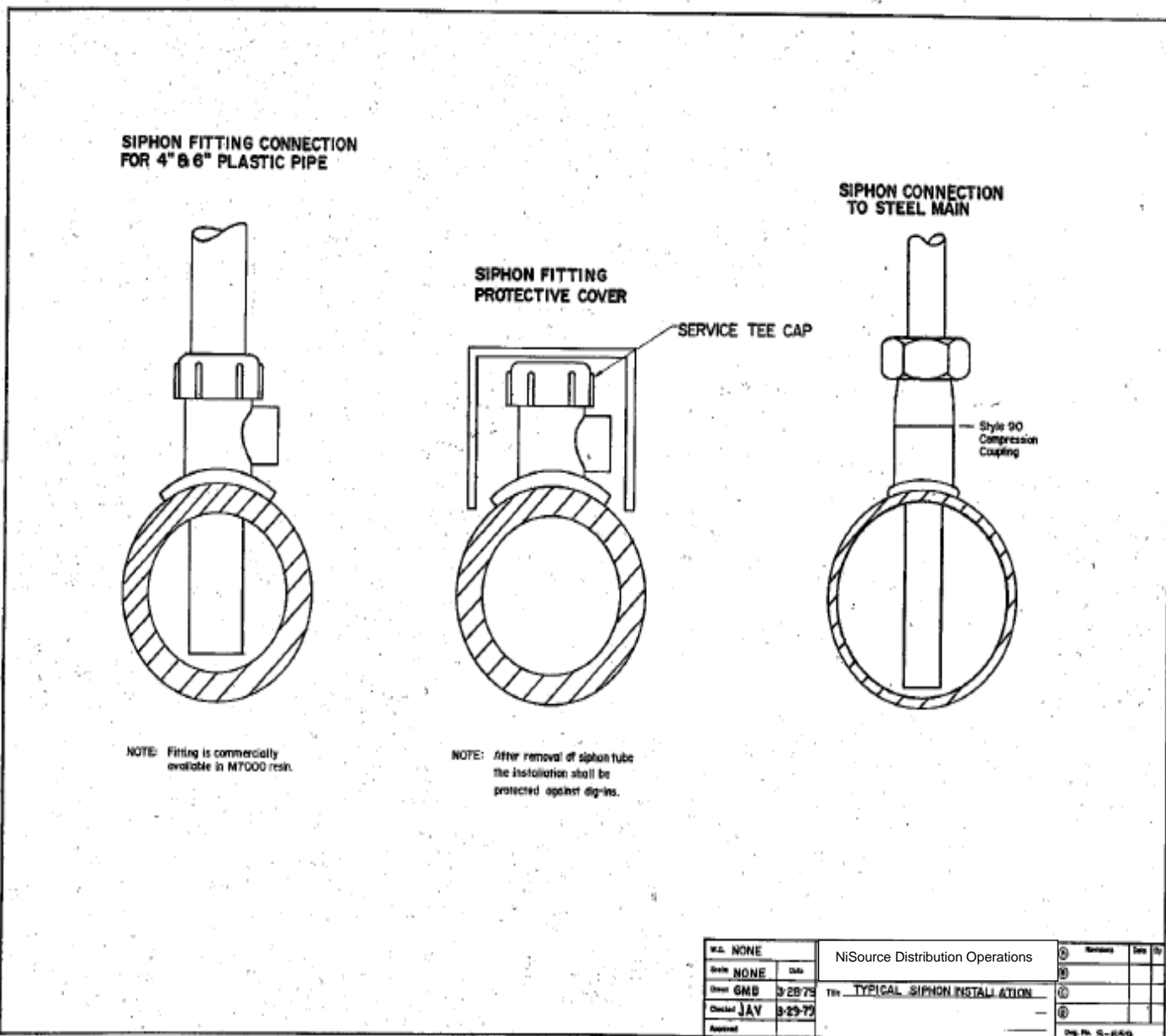
|                               |  |  |
|-------------------------------|--|--|
| Effective Date:<br>11/01/2013 | <b>Removal of Liquids from Pipelines</b> | Standard Number:<br><b>GS 5300.100</b> |
| Supersedes:<br>N/A            |  | Page 8 of 19                           |

**EXHIBIT A**



|                               |  |  |
|-------------------------------|--|--|
| Effective Date:<br>11/01/2013 | <b>Removal of Liquids from Pipelines</b> | Standard Number:<br><b>GS 5300.100</b> |
| Supersedes:<br>N/A            |  | Page 9 of 19                           |

**EXHIBIT B**



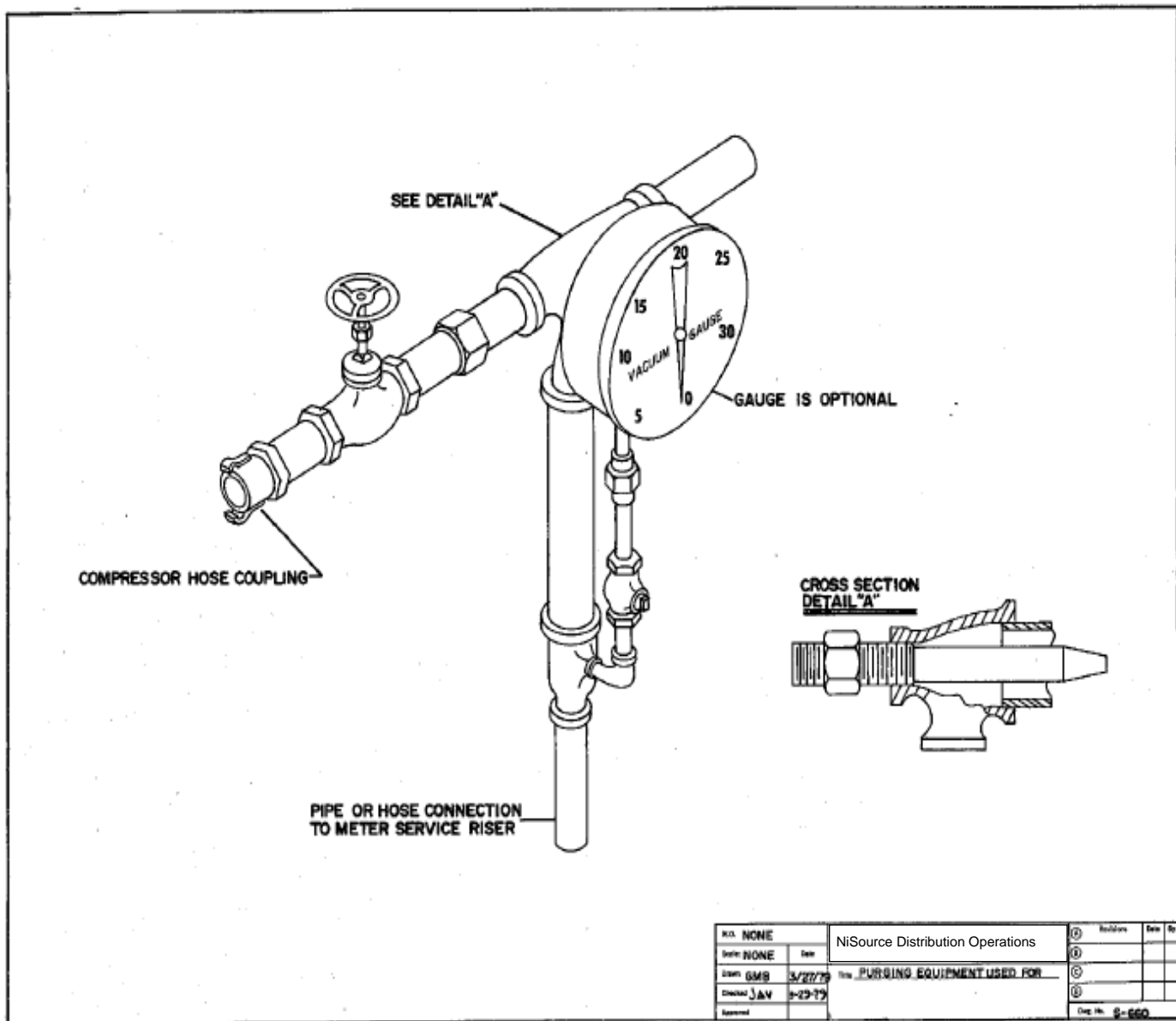


**Distribution Operations**

**Gas Standard**

|                               |  |  |
|-------------------------------|--|--|
| Effective Date:<br>11/01/2013 | <b>Removal of Liquids from Pipelines</b> | Standard Number:<br><b>GS 5300.100</b> |
| Supersedes:<br>N/A            |  | Page 10 of 19                          |

**EXHIBIT C**



|              |                                  |   |           |                 |    |
|--------------|----------------------------------|---|-----------|-----------------|----|
| REV. NONE    | NiSource Distribution Operations | ① | Revisions | Date            | By |
| Drawn: NONE  |                                  | ② |           |                 |    |
| Drawn: GMB   | 3/27/79                          | ③ |           |                 |    |
| Checked: JAV | 3-29-79                          | ④ |           |                 |    |
| Approved:    |                                  | ⑤ |           |                 |    |
|              |                                  |   |           | Orig. No. 8-650 |    |

4113 05-1070



**Distribution Operations**

**Gas Standard**

|                               |  |  |
|-------------------------------|--|--|
| Effective Date:<br>11/01/2013 | <b>Removal of Liquids from Pipelines</b> | Standard Number:<br><b>GS 5300.100</b> |
| Supersedes:<br>N/A            |  | Page 11 of 19                          |

**EXHIBIT D  
(1 of 3)**

Instructions for Completion of Form GS 5300.100-1 "Request for Liquid Sample Analysis"

The following items are keyed to Form GS 5300.100-1. Items 1, 11, 13 and 18 shall be completed by Operating area and 17 should be completed by the Testing Laboratory. Items 12, 14, 15, 16

| <u>Key</u> | <u>Item</u>                          | <u>Description</u>   |
|------------|--------------------------------------|--|
| 1          | Company                              | Check appropriate Company block  |
| 2          | Cost Center Area                     | Self-explanatory   |
| 3          | Operating Center                     | Self-explanatory   |
| 4          | Sample Identification No.            | A three part number consisting of the Area Location Number, the year, and a sequential number for the analysis in each Operating Center e.g. 2123/88/004 would denote the fourth analysis in 1988 in the Binghamton District and it would be from the Olean Area.  |
| 5          | Address or Location of Sample Source | Indicate source of sample, such as: <ul style="list-style-type: none"> <li>a. District Regulation No. XYZ</li> <li>b. Drip corner of Main and High Streets</li> <li>c. Storage Container I.D. No. 1234 at Staunton Service Center</li> <li>d. Tie-in at 4th Ave. and 10th Street under WO# 107-557-Loc-1234</li> </ul> |
| 6          | Municipality, County, State          | Self-explanatory.  |
| 7          | Oper. Map Number                     | Indicate Operation (or CPG Inventory) map number which contains area in which liquid was found.<br><br>Map number is not required if sample was taken from storage container at service center.  |



**Distribution Operations**

**Gas Standard**

|                               |  |  |
|-------------------------------|--|--|
| Effective Date:<br>11/01/2013 | <b>Removal of Liquids from Pipelines</b> | Standard Number:<br><b>GS 5300.100</b> |
| Supersedes:<br>N/A            |  | Page 12 of 19                          |

**EXHIBIT D  
(2 of 3)**

| <u>Key</u> | <u>Item</u>             | <u>Description</u>   |
|------------|-------------------------|--|
| 8          | Date Taken              | Indicate date sample was taken.  |
| 9          | By                      | Name of person who took sample.  |
| 10         | From                    | Indicate storage container I.D. No., if applicable.                      |
| 11         | Check Test(s) Requested | Self-explanatory.  |
| 12         | Test Results            | Completed by Testing Laboratory.   |
| 13         | Remarks                 | Include any information that is felt to be pertinent to sample analysis. |
| 14         | Laboratory Name         | Completed by Testing Laboratory.   |
| 15         | Test Performed By       | Completed by Testing Laboratory.   |
| 16         | Lab Report No.          | Completed by Testing Laboratory.   |
| 17         | Date                    | Completed by Testing Laboratory.   |
| 18         | Send Lab Report To      | Self-explanatory.  |



Distribution Operations

Gas Standard

|                               |  |  |
|-------------------------------|--|--|
| Effective Date:<br>11/01/2013 | <b>Removal of Liquids from Pipelines</b> | Standard Number:<br><b>GS 5300.100</b> |
| Supersedes:<br>N/A            |  | Page 13 of 19                          |

**EXHIBIT D**  
**(3 of 3)**

NiSource Distribution  
Operations

REQUEST FOR LIQUID SAMPLE ANALYSIS

|  |  |   |                      |                                |
|--|--|---|----------------------|--------------------------------|
| COMPANY <input type="checkbox"/> COH <input type="checkbox"/> CMA <input type="checkbox"/> CVA (1)<br><input type="checkbox"/> CKY <input type="checkbox"/> CMG <input type="checkbox"/> CPA |  | Cost Center (2)   | Operating Center (3) | SAMPLE IDENTIFICATION NO. (4)  |
| SAMPLE SOURCE DATA   | ADDRESS OR LOCATION OF SAMPLE SOURCE (5)                   |   |                      |                                |
|  | MUNICIPALITY: (6)  |   | STATE (6)            | OPER. MAP NUMBER (7)           |
|  | DATE TAKEN: (8)  | BY: (9)   | FROM: (10)           |                                |
| CHECK TEST(S) REQUESTED (11)   | TEST   | TEST RESULTS (12)<br>(To be completed by Testing Laboratory)  |                      |                                |
|  | PCB  | Aroclor 1242  | PPM; 1254            | PPM; 1260 PPM                  |
|  | PH   |   |                      |                                |
|  | BS&W   | % BY VOLUME   |                      |                                |
|  | FLASH POINT  | *F  |                      |                                |
|  | EP TOXICITY  |   |                      |                                |
|  | OTHER _____  |   |                      |                                |
| REMARKS (13)   |  |   |                      |                                |
| Note: Attach either Form C 2854, "Report of Liquid Found", or C 2855, "Pipeline Liquids-Disposal History", as applicable.  |  |   |                      |                                |
| LABORATORY NAME (14)   |  | TEST PERFORMED BY: (15)                                       | LAB REPORT NO. (16)  | DATE: (17)                     |
| SEND LAB REPORT TO (18)  | NAME (General Office):<br>Environmental Compliance Manager | MAILING ADDRESS:<br>4 Technology Drive, Westborough, MA 01581 |                      | TELEPHONE NO.:<br>508-836-7248 |
|  | NAME: From Operating Center                                | MAILING ADDRESS:  |                      | TELEPHONE NO.:                 |



**Gas Standard**

|                               |  |  |
|-------------------------------|--|--|
| Effective Date:<br>11/01/2013 | <b>Removal of Liquids from Pipelines</b> | Standard Number:<br><b>GS 5300.100</b> |
| Supersedes:<br>N/A            |  | Page 14 of 19                          |

**EXHIBIT E  
(1 of 2)**

Instructions for Completion of Form GS 5300.100-2  
 "Report of Liquid Found"

The following are keyed to Form Form GS 5300.100-2.

| Key | Item  | Description  |
|-----|---|--|
| 1   | Company   | Self Explanatory   |
| 2   | <span style="border: 1px solid black; padding: 2px;">Cost Center</span> | Self Explanatory   |
| 3   | Report No.  | A sequential Report Number designated by each district.  |
| 4   | Date  | Self Explanatory   |
| 5   | Location  | Location where liquid was removed.   |
| 6   | "Reg.-Meas. Station"  | Check appropriate box and provide station number, if appropriate.  |
| 7   | Date of Last Inspection   | Self Explanatory   |
| 8   | Location of Liquid Found  | Check appropriate box. Use additional column if liquid is found in more than one piece of equipment. If "other" is checked, explain under remarks.                             |
| 9   | Description of Liquid Removed   | Check appropriate box.   |
| 10  | Amount of Liquid Found  | Check appropriate box and furnish approximate volume.  |
| 11  | Source of Liquid if Known   | Check appropriate box.   |
| 12  | Transferred to Storage Container  | Check "yes," if liquid is drained into storage container from collection container. Give date of transfer.   |
| 13  | Location and ID Marking on Storage Container                            | Provide location and ID number of storage container from Form <span style="border: 1px solid black; padding: 2px;">GS 5300.100-3</span> "Pipeline Liquids - Disposal History." |
| 14  | Remarks   | Enter any additional information which may describe the origin and nature of the liquid removed and any problems noted when liquids were removed.                              |



Distribution Operations

Gas Standard

|                               |  |  |
|-------------------------------|--|--|
| Effective Date:<br>11/01/2013 | <b>Removal of Liquids from Pipelines</b> | Standard Number:<br><b>GS 5300.100</b> |
| Supersedes:<br>N/A            |  | Page 15 of 19                          |

**EXHIBIT E**  
**(2 of 2)**

NiSource Distribution Operations

**REPORT OF LIQUID FOUND**

|   |  |  |  |
|---|--|--|--|
| COMPANY<br>(1) <input type="checkbox"/> COH <input type="checkbox"/> CMA <input type="checkbox"/> CVA<br><input type="checkbox"/> CPA <input type="checkbox"/> CMD <input type="checkbox"/> CKY |  | DISTRICT<br>(2)  | REPORT NO.<br>(3)  |
| LOCATION<br>(5)   |  | DATE<br>(4)  |  |
| <input type="checkbox"/> REG. STATION   | NUMBER<br>(6)  | DATE OF LAST INSPECTION (MO/YR)<br>(7)   |  |
| <input type="checkbox"/> MEAS. STATION  |  |  |  |
| LOCATION OF LIQUID FOUND (8)  | <input type="checkbox"/> METER <input type="checkbox"/> REG.<br><input type="checkbox"/> DRIP <input type="checkbox"/> OTHER*                  | <input type="checkbox"/> METER <input type="checkbox"/> REG.<br><input type="checkbox"/> DRIP <input type="checkbox"/> OTHER*                  | <input type="checkbox"/> METER <input type="checkbox"/> REG.<br><input type="checkbox"/> DRIP <input type="checkbox"/> OTHER*                  |
| DESCRIPTION OF LIQUID REMOVED (9)   | <input type="checkbox"/> WATER <input type="checkbox"/> HEAVY OIL<br><input type="checkbox"/> LIGHT OIL <input type="checkbox"/> OTHER*        | <input type="checkbox"/> WATER <input type="checkbox"/> HEAVY OIL<br><input type="checkbox"/> LIGHT OIL <input type="checkbox"/> OTHER*        | <input type="checkbox"/> WATER <input type="checkbox"/> HEAVY OIL<br><input type="checkbox"/> LIGHT OIL <input type="checkbox"/> OTHER*        |
| AMOUNT OF LIQUID FOUND (10)   | <input type="checkbox"/> OZ _____ <input type="checkbox"/> QTS _____<br><input type="checkbox"/> PTS _____ <input type="checkbox"/> GALS _____ | <input type="checkbox"/> OZ _____ <input type="checkbox"/> QTS _____<br><input type="checkbox"/> PTS _____ <input type="checkbox"/> GALS _____ | <input type="checkbox"/> OZ _____ <input type="checkbox"/> QTS _____<br><input type="checkbox"/> PTS _____ <input type="checkbox"/> GALS _____ |
| SOURCE OF LIQUID IF KNOWN (11)  | <input type="checkbox"/> LOC PROD <input type="checkbox"/> BKN MAIN<br><input type="checkbox"/> TRANS. CO. <input type="checkbox"/> OTHER*     | <input type="checkbox"/> LOC PROD <input type="checkbox"/> BKN MAIN<br><input type="checkbox"/> TRANS. CO. <input type="checkbox"/> OTHER*     | <input type="checkbox"/> LOC PROD <input type="checkbox"/> BKN MAIN<br><input type="checkbox"/> TRANS. CO. <input type="checkbox"/> OTHER*     |
| TRANSFERRED TO STORAGE CONTAINER (12) <input type="checkbox"/> YES <input type="checkbox"/> NO  |  | IF YES, GIVE DATE OF TRANSFER  |  |
| LOCATION AND ID. MARKING ON STORAGE CONTAINER<br>(13)   |  |  |  |

\* REMARKS (ALSO BRIEFLY INDICATE EQUIPMENT DAMAGE AND CONDITION, INTERRUPTION OF SERVICE ETC, IF APPLICABLE) (14)

Form GS 5300.100-2





Distribution Operations

Gas Standard

|                               |  |  |
|-------------------------------|--|--|
| Effective Date:<br>11/01/2013 | <b>Removal of Liquids from Pipelines</b> | Standard Number:<br><b>GS 5300.100</b> |
| Supersedes:<br>N/A            |  | Page 16 of 19                          |

**EXHIBIT F  
(1 of 4)**

Instructions for Completion of Form GS 5300.100-3  
"Pipeline Liquids - Disposal History"

The following are keyed to Form GS 5300.100-3 of this Exhibit.

| <u>Key</u> | <u>Item</u>  | <u>Description</u>   |
|------------|--|--|
| 1          | Company  | Self-explanatory.  |
| 2          | <span style="border: 1px solid black; padding: 2px;">Operating Center</span> | Self-explanatory.  |
| 3          | Storage Container ID Marking   | Provide the permanent identification number assigned to and marked on the storage container. A suggested format may be area location number/container number. For example 1231/005 would be from container number 5 from the Findlay Area, Lake Erie District. |
| 4          | Container Description  | Provide capacity and type material of container, example "55 gallon steel drum."   |
| 5          | Location of Container During Storage   | Provide general location of container, such as Findlay Service Center.   |
| 6          | Date Sample Taken  | Self-explanatory.  |
| 7          | Date Results Received  | Self-explanatory.  |
| 8          | Laboratory   | Initials or name of laboratory which tested sample.  |
| 9          | Transporter Name, Address, Phone Number and Driver's Name                    | Self-explanatory.  |
| 10         | Transporter EPA ID Number  | Self-explanatory.  |
| 11         | Shipping Date  | Date on which transporter picked up storage container for disposal.  |
| 12         | Loading Location   | Complete only if container was moved to different site for pick-up.  |



Distribution Operations

Gas Standard

|                               |  |  |
|-------------------------------|--|--|
| Effective Date:<br>11/01/2013 | <b>Removal of Liquids from Pipelines</b> | Standard Number:<br><b>GS 5300.100</b> |
| Supersedes:<br>N/A            |  | Page 17 of 19                          |

**EXHIBIT F  
(2 of 4)**

| <u>Key</u>   | <u>Item</u>                        | <u>Description</u>   |
|--|------------------------------------|--|
| 13   | Disposal Facility Name and Address | Self-explanatory.  |
| 14   | Facility EPA ID Number             | Indicate the EPA ID number for the disposal facility.                |
| 15   | Type of Disposal                   | Check appropriate block.   |
| 16   | Date of Transporter Arrival        | Record anticipated arrival date of transporter at disposal facility. |
| 17   | Date of Manifest Return            | Date when signed manifest is received from disposal facility.        |
| 18   | "Certificate of Disposal"          | Check appropriate box.   |
| 19   | "Date Certificate Received"        | Self-explanatory.  |
| <p>The following items may be found from the corresponding Form <span style="border: 1px solid black; padding: 2px;">GS 5300.100-2</span><br/>                     "Report of Liquid Found" for each liquid collection emptied into the storage container.</p> |                                    |  |
| 20   | Report Number                      | Item 3, Exhibit E  |
| 21   | Date                               | Item 4, Exhibit E  |
| 22   | Quantity of Liquid                 | Item 10, Exhibit E   |
| 23   | Collection Location                | Items 5, 6 & 8, Exhibit E  |
| 24   | Description of Liquid              | Item 9, Exhibit E  |



Distribution Operations

Gas Standard

|                               |  |  |
|-------------------------------|--|--|
| Effective Date:<br>11/01/2013 | <b>Removal of Liquids from Pipelines</b> | Standard Number:<br><b>GS 5300.100</b> |
| Supersedes:<br>N/A            |  | Page 18 of 19                          |

**EXHIBIT F**  
**(3 of 4)**

|  |  |   |  |
|--|--|---|--|
| <div style="border: 1px solid black; display: inline-block; padding: 2px;">NiSource Distribution Operations</div>  |  | PIPELINE LIQUIDS—<br>DISPOSAL HISTORY                         |  |
| COMPANY <input type="checkbox"/> COH <input type="checkbox"/> CMA <input type="checkbox"/> CVA <input type="checkbox"/> CKY <input type="checkbox"/> CMD <input type="checkbox"/> CKY <input type="checkbox"/> Cost Center |  |   |  |
| (1)  |  | (2)   |  |
| STORAGE CONTAINER ID MARKING (3)   |  | CONTAINER DESCRIPTION (4)                                     |  |
| LOCATION OF CONTAINER DURING STORAGE (5)   |  |   |  |
| SEE REVERSE SIDE FOR RECORD OF LIQUID COLLECTION   |  |   |  |
| SAMPLING RECORD  |  |   |  |
| DATE SAMPLE TAKEN / (6) /  |  | DATE RESULTS RECEIVED / (7) /                                 |  |
| LABORATORY (8)   |  |   |  |
| COMPLETE THE FOLLOWING IF DISPOSAL IS REQUIRED   |  |   |  |
| TRANSPORT RECORD   |  |   |  |
| TRANSPORTER NAME   |  | (9)   |  |
| ADDRESS  |  | (9)   |  |
|  |  | CITY: STATE: ZIP:   |  |
| PHONE NUMBER   |  | ( ) (9)   |  |
| TRANSPORTER EPA ID NUMBER  |  | (10)  |  |
| DRIVER'S NAME  |  | (9)   |  |
| SHIPPING DATE  |  | / / (11)  |  |
| LOADING LOCATION<br>(if other than storage location)   |  | (12)  |  |
| DISPOSAL RECORD  |  |   |  |
| DISPOSAL FACILITY NAME   |  | (13)  |  |
| ADDRESS  |  | (13)  |  |
|  |  | CITY: STATE: ZIP:   |  |
| FACILITY EPA ID NUMBER   |  | (14)  |  |
| TYPE OF DISPOSAL (15) <input type="checkbox"/> INCINERATION <input type="checkbox"/> LANDFILL <input type="checkbox"/> OTHER (explain) _____   |  |   |  |
| DATE OF TRANSPORTER ARRIVAL  |  | / (16) /  |  |
| DATE OF MANIFEST RETURN  |  | / (17) /  |  |
| DID THE FACILITY ISSUE A CERTIFICATE OF DISPOSAL?  |  | <input type="checkbox"/> YES <input type="checkbox"/> NO (18) |  |
| IF YES, GIVE DATE CERTIFICATE RECEIVED   |  | / / (19)  |  |
| Form GS 5300.100-3   |  |   |  |





**Distribution Operations**

**Gas Standard**

|                               |                            |  |
|-------------------------------|----------------------------|--|
| Effective Date:<br>01/15/2013 | <b>Upgrading - General</b> | Standard Number:<br><b>GS 5500.200</b> |
| Supersedes:<br>04/30/1990     |                            | Page 1 of 2                            |

Companies Affected:

|                                 |   |   |
|---------------------------------|---|---|
| <input type="checkbox"/> NIPSCO | <input checked="" type="checkbox"/> CGV | <input checked="" type="checkbox"/> CMD |
|                                 | <input checked="" type="checkbox"/> CKY | <input checked="" type="checkbox"/> COH |
|                                 | <input type="checkbox"/> CMA            | <input checked="" type="checkbox"/> CPA |

**REFERENCE** Code of Federal Regulations - Title 49 - Part 192 - Subpart K - Upgrading

**1. GENERAL**

Standard Series 5500 shall be followed whenever necessary to increase the Maximum Allowable Operating Pressure (MAOP) of an existing distribution system. This series provides a method for increasing the MAOP without taking the distribution system out of service. However, a system having its MAOP increased should be examined to determine if it can be economically taken out of service and pressure tested. If so, all upgrading steps must be followed except the incremental pressure increases and leakage inspections. The test pressure shall be in accordance with the GS 1500.010 "Pressure Testing" Series of standards..

GS 1660.020 "Maximum Allowable Operating Pressure (MAOP)" describes the criteria necessary to document a MAOP change.

**2. RESPONSIBILITY**

The Field is responsible for initiating any upgrading investigation to determine the feasibility of increasing the MAOP, changing the system design pressure designation, and for evaluating the system to determine the safety and economics of upgrading. Field Engineers are also responsible to notify personnel associated with the transmission integrity management program (TRIMP) of planned and completed upgrades which involve an existing transmission line or a distribution line where the new upgraded MAOP would result in a hoop stress greater than 20% of the Specified Minimum Yield Strength of the pipe.

The appropriate Field Leader and other field employees shall advise the Field Engineer of any existing or anticipated conditions where the existing MAOP may not meet operating requirements.

**3. UPGRADING JUSTIFICATION**

Upgrading justification is based on the need to increase distribution system capacity and/or to provide adequate service pressure to customers. This need may be caused by:

- a. Pipeline network changes as a result of facilities replacements, abandonments or modifications.
- b. Contractual and/or operational conditions that affect the source(s) of supply.

*This document is considered CONTROLLED only when viewed electronically on the Company's intranet. Printed or other electronic copies may not be current, and the intranet version should be used to verify.*



**Distribution Operations**

**Gas Standard**

|                               |                           |  |
|-------------------------------|---------------------------|--|
| Effective Date:<br>01/15/2013 | <b>Uprating - General</b> | Standard Number:<br><b>GS 5500.200</b> |
| Supersedes:<br>04/30/1990     |                           | Page 2 of 2                            |

- c. Additional volume or pressure requirements caused by existing or new customers.

**4. LIMITATIONS**

A new MAOP established under this operating procedure shall not exceed the maximum that would be allowed for a new segment of pipeline constructed of the same material in the same location.



**Distribution Operations**

**Gas Standard**

|                               |  |  |
|-------------------------------|--|--|
| Effective Date:<br>01/01/2014 | <b>Upgrading - Preliminary Investigation</b> | Standard Number:<br><b>GS 5500.300</b> |
| Supersedes:<br>N/A            |  | Page 1 of 9                            |

Companies Affected:

|                                 |   |   |
|---------------------------------|---|---|
| <input type="checkbox"/> NIPSCO | <input checked="" type="checkbox"/> CGV | <input checked="" type="checkbox"/> CMD |
|                                 | <input checked="" type="checkbox"/> CKY | <input checked="" type="checkbox"/> COH |
|                                 | <input type="checkbox"/> CMA            | <input checked="" type="checkbox"/> CPA |

**REFERENCE** 49 CFR Part 192 - Subpart K

**1. SCOPE**

This standard describes the steps and investigations to determine the feasibility and estimated cost of increasing the MAOP of a pipeline or segment of a pipeline.

**2. GENERAL**

Uncoated steel pipelines may not be upgraded without a signed waiver from the Vice President of Engineering and Construction and the Vice President of Pipeline Safety and Compliance.

**3. INTERMEDIATE PRESSURE (I.P.) UPRATINGS**

Responsibilities for I.P. upratings are as follows:

**3.1 Field Engineer**

- a. Shall supply maps to the Field Operations and/or Construction Leaders and Corrosion Technician which show the systems to be upgraded. These maps shall indicate the location of all points of separation, tie-ins, valving, and temporary and/or permanent pressure control equipment.
- b. Shall review with assistance from Field Operations and corrosion personnel the design, pressure tests, operating and maintenance history of the pipeline segments to be upgraded including fittings.
- c. Shall review recommendations of the Field Operations and/or Construction Leaders and Corrosion Technician.
- d. Should review upgrading cost estimates and evaluate against other alternatives.
- e. Shall submit recommendations to the Operations Center Manager and /or Construction Manager.

*This document is considered CONTROLLED only when viewed electronically on the Company's intranet. Printed or other electronic copies may not be current, and the intranet version should be used to verify.*



**Distribution Operations**

**Gas Standard**

|                               |   |  |
|-------------------------------|---|--|
| Effective Date:<br>01/01/2014 | <b>Uprating - Preliminary Investigation</b> | Standard Number:<br><b>GS 5500.300</b> |
| Supersedes:<br>N/A            |   | Page 2 of 9                            |

**3.2 Field Operations and/or Construction Leaders**

- a. Shall review all cleared and open leak orders for the area under investigation. If there has not been a leak inspection within the last twelve (12) months, a leak inspection shall be conducted. The leak orders shall be posted on the Field Engineer's map, showing date order was written or repairs were made, material used in repair, condition of main, classification of order and any other pertinent data. If the leak history indicates the mains are in acceptable condition, subsequent steps b. and c. shall be followed. However, if in the opinion of the Field Operations and/or Construction Leaders any mains are not acceptable for uprating, the Field Engineer shall be advised.
- b. Shall review the history of the pipeline and make an on-site inspection of the area to review conditions that deserve special attention during the proposed uprate. This may include observation of structures or facilities in close proximity to the main or past or current construction activity by third parties that could affect the pipeline's condition.
- c. Shall make visual inspection at locations selected by the Corrosion Technician.
- d. Shall determine the number of meters involved. (This can be obtained from on-site inspection, service line orders, meter reading route books, register sheets, and any other means to insure that all customers within the area to be uprated are included.)
- e. Shall review latest customer service line and main line leakage survey records and, if none was performed within the past twelve months, schedule a survey for all mains and customer service lines in the uprate area according to GS 1708.020 "Leakage Surveys" prior to any pressure elevation in the system.
- f. Shall make an investigation to determine the number of unmetered gas lights that may be in the system.
- g. Shall investigate to see if there are any service regulators with inadequate relief capacity or any other service regulators including mercury regulators that must be replaced.
- h. Shall provide the Field Engineer a general recommendation of the effect of the uprating on customer-owned facilities.
- i. Shall provide cost data for the uprating, installation of new pipe or pipeline components and any required replacement of pipe and pipeline components (i.e., prone-to-fail risers).
- j. Shall make a recommendation on the feasibility of the uprating to the Field Engineer.





**Distribution Operations**

**Gas Standard**

|                               |  |  |
|-------------------------------|--|--|
| Effective Date:<br>01/01/2014 | <b>Upgrading - Preliminary Investigation</b> | Standard Number:<br><b>GS 5500.300</b> |
| Supersedes:<br>N/A            |  | Page 3 of 9                            |

**3.3 Corrosion Technician**

- a. Shall evaluate the effect of the uprate on cathodic protection to include recommendations and costs for establishing or maintaining protection.
- b. Shall, when leakage history so indicates, determine if there are “areas of active corrosion” and recommend locations for visual inspection.

**4. MEDIUM PRESSURE (M.P.) UPRATINGS**

Responsibilities for M.P. upratings are as follows:

**4.1 Field Engineer**

- a. Shall review operation maps to determine the type of main(s) material. Cast (ductile) iron shall not be uprated to M.P. unless the prior approvals of Vice President-Engineering and Construction and the Vice President of Pipeline Safety and Compliance are received. Guidance regarding cast (ductile) iron can be found in GS 1780.010 “Cast Iron – General.”
- b. Shall investigate all valves on mains to determine body rating, flange rating, and location. (If this information is not available from local records, the valves shall be exposed and the information secured. If the rating cannot be determined by visual inspection, uprating plans and estimates shall include removal or replacement of the valves.)
- c. Shall review recommendations of GS 2400.010 or GS 2400.010(OH) “Critical Valve Design Guidelines,” and make recommendations for the installation of additional valves, if deemed appropriate.
- d. Shall supply maps to the Field Operations and/or Construction Leaders and Corrosion Technician which show the systems to be uprated. These maps shall indicate the location of all points of separation, tie-ins, valves, and temporary and/or permanent pressure control equipment. .
- e. Shall review with assistance from Field Operations and corrosion personnel the design, pressure tests, operating and maintenance history of the pipeline segments to be uprated including fittings.
- f. Shall consult with the Field Operations and/or Construction Leaders to determine if it is feasible to take the system out of service and conduct a pressure test in accordance with GS 1500.010 or GS 1500.010(OH) “Pressure Testing.”
- g. Shall investigate Regulator station and Measurement setting valves, fittings, and appurtenances for any equipment that must be replaced.
- h. Shall review recommendations of the Field Operations and/or Construction Leaders and Corrosion Technician.
- i. Should review uprating cost estimates and evaluate against other



**Distribution Operations**

**Gas Standard**

|                               |   |  |
|-------------------------------|---|--|
| Effective Date:<br>01/01/2014 | <b>Uprating - Preliminary Investigation</b> | Standard Number:<br><b>GS 5500.300</b> |
| Supersedes:<br>N/A            |   | Page 4 of 9                            |

alternatives.

- j. Shall submit recommendations to the Operating Center Manager and/or Construction Manager.

**4.2 Field Operations and/or Construction Leaders**

- a. Shall review all cleared and open leak orders for the area under investigation. If there has not been a leak inspection within the last twelve (12) months, a leak inspection shall be conducted. The leak orders shall be posted on the Field Engineer's map, showing date order was written or repairs were made, material used in repair, condition of main, classification of order and any other pertinent data. If the leak history indicates the mains are in acceptable condition, the subsequent steps shall be followed. However, if in the opinion of the Field Operations and/or Construction Leaders any mains are not acceptable for uprating, the Field Engineer shall be advised.
- b. Shall review the history of the pipeline and make an on-site inspection of the area to review conditions that deserve special attention during the proposed uprate. This may include observation of structures or facilities in close proximity to the main or past or current construction activity by third parties that could affect the pipeline's condition.
- c. Shall make visual inspection at locations selected by the Corrosion Technician.
- d. Shall determine the presence of bends and dead ends that may contain mechanical couplings. He shall prepare cost estimates to reinforce or anchor.
- e. Shall, on mains joined by mechanical couplings, investigate leakage records to determine incidents of coupling leakage resulting in repair.
- f. Shall review service line information to determine service lines not meeting the minimum standards for M.P. service. Uprating cost data shall be supplied to the Field Engineer. The minimum standards include a shut off device at the main (i.e. shut off service tee, Shortstopp tee, etc.).
- g. Shall determine the number of meters involved. (This can be obtained from on-site inspection, service line orders, meter reading route books, register sheets, and any other means to insure that all customers within the area to be uprated are included.)
- h. Shall review latest customer service line and main line leakage survey records and, if none was performed within the past twelve months, schedule a survey for all mains and customer service lines in the uprate area according to GS 1708.020 "Leakage Surveys" prior to any pressure elevation in the system.
- i. Shall make an investigation to determine the number of unmetered gas



|                               |   |  |
|-------------------------------|---|--|
| Effective Date:<br>01/01/2014 | <b>Uprating - Preliminary Investigation</b> | Standard Number:<br><b>GS 5500.300</b> |
| Supersedes:<br>N/A            |   | Page 5 of 9                            |

lights that may be in the system.

- j. Shall provide the Field Engineer with a general recommendation of the effect of the uprating on customer-owned facilities.
- k. Shall investigate, when I.P. is converted to M.P., to see if there are any service regulators with inadequate relief capacity or any other obsolete service regulators including mercury regulators that must be replaced.
- l. Shall provide cost data for the uprating, installation of new pipe or pipeline components and any required replacement of pipe and pipeline components.
- m. Shall make recommendation on the feasibility of the uprating to the Field Engineer.

**4.3 Corrosion Technician**

- a. Shall evaluate the effect of the uprate on cathodic protection to include recommendations and costs for establishing or maintaining protection.
- b. Shall, when leakage history so indicates, determine if there are "areas of active corrosion" and recommend locations for visual inspection.

**5. HIGH PRESSURE (H.P.) UPRATINGS**

For steel pipeline where X-ray records cannot be reviewed and the proposed uprated pressures is in excess of 150 PSIG, a random selected sampling of 10 or 25% whichever is less of the existing welds will be examined by X-ray to determine the quality of the weld. The weld shall pass the current requirements of API 1104.

Responsibilities for H.P. uprating are as follows:

**5.1 Field Engineer**

- a. Shall review operation maps to determine the type of main material. Cast (ductile) iron and screw collar mains shall not be uprated to H.P. Approval for plastic mains being considered for H.P. is required of the Vice President of Engineering and Construction and the Vice President of Pipeline Safety and Compliance. Steel mains joined by mechanical couplings shall be reviewed to determine the maximum allowable operating pressure (MAOP) of the joint. Local records shall be researched to determine the pipe grade, wall thickness, type of longitudinal joints and original test pressure. When this information is not available locally, field investigations to determine the pipe grade, wall thickness, longitudinal joint type can be conducted. If field investigations are not conducted or fail to determine any of the pipe properties the Field Engineer can request a search of Vital Records. When information is not available, the Field Engineer shall assume that the pipe has the following properties:



**Distribution Operations**

**Gas Standard**

|                               |   |  |
|-------------------------------|---|--|
| Effective Date:<br>01/01/2014 | <b>Uprating - Preliminary Investigation</b> | Standard Number:<br><b>GS 5500.300</b> |
| Supersedes:<br>N/A            |   | Page 6 of 9                            |

1. Specified Minimum Yield Strength (SMYS) of 24,000 psi.
2. Longitudinal joint factor of 0.60, for 4 inch or less; 0.80, for over 4 inch.
3. Design factor 0.40.
4. Wall thickness equal to the least nominal wall thickness permitted for that diameter pipe.
5. That all pipe 4 inch and less is Furnace Butt Welded pipe and shall not be used at a pressure in excess of 300 psig.

From this information, the Field Engineer can establish a limit for the MAOP of the system.

- b. Shall investigate the following:
  1. All valves on mains to determine body rating, flange rating, and location. (If the rating information is not available from local records, the valve shall be exposed and the information secured. If the rating cannot be determined by visual inspection, uprating plans and estimates shall include removal or replacement of the valve.)
  2. The recommendations of GS 2400.010 or GS 2400.010(KY) "Critical Valve Design Guidelines," and make recommendations for the installation of additional valves, if deemed appropriate.
  3. Regulator station and Measurement settings valves, fittings, and appurtenances. Any equipment found not suitable for newly constructed facilities of a like design shall be identified for removal or reinforcement.
  4. All branch connections and side taps. Connections not suitable for newly constructed facilities of a like design shall be identified for removal or reinforcement. Field fabricated or mitered tees, elbows, etc., shall not be considered suitable for H.P. systems.
- c. Shall specify pressure testing for systems to operate at or above 100 psig, if the original test pressure was not at a level suitable for the new MAOP. The test pressure shall be in accordance with GS 1500.010 or GS 1500.010(OH) "Pressure Testing," except that natural gas may be used as the testing medium, if available, and if it is desirable to keep the system continuously in service. However, natural gas may not be used as a test medium if the stress level of any portion of the system will exceed 30% of SMYS during the test.

Note: Since this will result in a test pressure of 1.5 times the new MAOP, all materials must be capable of withstanding the test pressure.



**Distribution Operations**

**Gas Standard**

|                               |   |  |
|-------------------------------|---|--|
| Effective Date:<br>01/01/2014 | <b>Uprating - Preliminary Investigation</b> | Standard Number:<br><b>GS 5500.300</b> |
| Supersedes:<br>N/A            |   | Page 7 of 9                            |

If the system supply pressure is not capable of providing the desired test pressure a waiver of this test requirement may be requested from the Vice President-Engineering and Construction and Vice President of Pipeline Safety and Compliance.

When using natural gas as the test medium, the pressure shall be increased according to GS 5500.400 or GS 5500.400(OH) and the test performed according to GS 5500.500 or GS 5500.500(VA) except that the leak survey required 7 to 15 days after the completed uprate shall be at the newly established MAOP.

- d. Shall supply maps to the Field Operations and/or Construction Leaders and Corrosion Technician which show the systems to be uprated. These maps shall indicate the location of all points of proposed separation, tie-ins, existing and proposed main line valves, points where visual inspections are to be made and temporary and/or permanent pressure regulator control equipment.
- e. Shall review with assistance from Field Operations and corrosion personnel the design, pressure tests, operating and maintenance history of the pipeline segments to be uprated including fittings.
- f. Shall consult with the Field Operations and/or Construction Leaders to determine if it is feasible to take the system out of service and conduct a pressure test in accordance with GS 1500.010 or GS 1500.010(OH) "Pressure Testing."
- g. Shall review recommendations of the Field Operations and/or Construction Leaders and Corrosion Technician.
- h. Should review uprating cost estimates and evaluate against other alternatives.
- i. Shall submit recommendations to the Operations Center Manager and /or Construction Manager.

**5.2 Field Operations and/or Construction Leaders**

- a. Shall review all cleared and open leak orders for the area under investigation. If there has not been a leakage inspection made within the last 12 months, a leak inspection shall be conducted. The leak orders shall be posted on the Field Engineer's map, showing date order was written or repairs were made, materials used in repair, condition of main, classification of order and other pertinent data. If the leak history indicates that the mains are in acceptable condition, the subsequent steps shall be followed. If in the opinion of the Field Operations and/or Construction Leaders any mains are not acceptable for uprating the Field Engineer shall be advised.
- b. Shall review the history of the pipeline and make an on-site inspection of



**Distribution Operations**

**Gas Standard**

|                               |   |  |
|-------------------------------|---|--|
| Effective Date:<br>01/01/2014 | <b>Uprating - Preliminary Investigation</b> | Standard Number:<br><b>GS 5500.300</b> |
| Supersedes:<br>N/A            |   | Page 8 of 9                            |

the area. The purpose of this review and inspection is to determine whether there has been any third party excavation activity that might have removed any of the pipeline's cover or caused damage to the facility. If the area has experienced development activity since construction of NiSource facilities, the depth and alignment shall be checked using a locator. Where the depth is less than that required for new construction, random visual examinations (test holes) shall be made to look for damages. Any pipe section found to lack cover or been subject to damage shall be recommended for corrective action. Consideration shall also be given to the proximity of structures or facilities that have been installed after the main installation and any apparent clearance not in accord with "new construction" standards shall be recommended for corrective action.

- c. Shall make visual inspection at locations selected by the Corrosion Technician.
- d. Shall determine the presence of bends, offsets, tie-ins, and dead ends that may contain mechanical couplings and prepare cost estimates to remove, reinforce or anchor.
- e. Shall, on mains joined by mechanical couplings, investigate leakage records to determine incidents of coupling leakage resulting in repair.
- f. Shall review service line information to determine service lines not meeting the minimum standards for H.P. service lines. Uprating cost data shall be supplied the Field Engineer. Refer to GS 3020.010 "Service Line Installation" for minimum standards.
- g. Shall determine the number of meters involved. (This can be obtained from on-site inspection, service line orders, meter reading route books, register sheets, and any other means to insure that all customers within the area to be uprated are included.)
- h. Shall review latest customer service line and main line leakage survey records and, if none was performed within the past twelve months, schedule a survey for all mains and customer service lines in the uprate area according to GS 1708.020 "Leakage Surveys" prior to any pressure elevation in the system.
- i. Shall make an investigation to determine the number of unmetered gas lights that may be in the system.
- j. Shall, when an I.P. or M.P. system is being proposed for uprating to H.P., determine the adequacy of existing regulation and need for additional pressure control requirements for each customer including replacements of mercury regulators. Refer to GS 6400.420(CG) "High Pressure Service Regulator and Meter Setting Selection."
- k. Shall provide the Field Engineer a general recommendation of the effect of the uprating on customer-owned facilities.



**Distribution Operations**

**Gas Standard**

|                               |  |  |
|-------------------------------|--|--|
| Effective Date:<br>01/01/2014 | <b>Upgrading - Preliminary Investigation</b> | Standard Number:<br><b>GS 5500.300</b> |
| Supersedes:<br>N/A            |  | Page 9 of 9                            |

- l. Shall provide cost data for the upgrading, installation of new pipe or pipeline components and any required replacement of pipe and pipeline components.
- m. Shall make a recommendation on the feasibility of the upgrading to the Field Engineer.

**5.3 Corrosion Technician**

- a. Shall evaluate the effect of the uprate on cathodic protection to include recommendations and costs for establishing or maintaining protection.
- b. Shall, when leakage history so indicates, determine if there are any areas of active corrosion and recommend locations for visual inspection.





|                               |                                      |  |
|-------------------------------|--------------------------------------|--|
| Effective Date:<br>01/01/2014 | <b>Upgrading - Preparatory Steps</b> | Standard Number:<br><b>GS 5500.400</b> |
| Supersedes:<br>N/A            |                                      | Page 1 of 14                           |

Companies Affected:

|                                 |   |   |
|---------------------------------|---|---|
| <input type="checkbox"/> NIPSCO | <input checked="" type="checkbox"/> CGV | <input checked="" type="checkbox"/> CMD |
|                                 | <input checked="" type="checkbox"/> CKY | <input checked="" type="checkbox"/> COH |
|                                 | <input checked="" type="checkbox"/> CMA | <input checked="" type="checkbox"/> CPA |

**REFERENCE** 49 CFR Part 192 – Subpart K

**1. SCOPE**

This standard set forth the requirements and responsibilities to develop a plan and procedure to increase the MAOP of a pipeline or segment of a pipeline. This standard also set forth the responsibilities to complete preparatory steps for the upgrading procedure to be completed

**2. DEFINITIONS**

L.P. – Low Pressure - operating pressure at or below 14 inches of water

I.P. – Intermediate Pressure – operating pressure between 14 inches of water and 10 PSIG

M.P. – Medium Pressure – operating pressure between 10 PSIG and 60 PSIG

H.P. – High Pressure – operating pressures greater than 60 PSIG

Class Location Factor –

- a. Class 1 Location Factor = 1.1
- b. Class 2 Location Factor = 1.25
- c. Class 3 Location Factor = 1.5
- d. Class 4 Location Factor = 1.5

**3. FIELD ENGINEER**

After receiving approval from the Operations Center Manager (or equivalent) of the proposed uprate, a Type 0001 “Miscellaneous Maintenance and Jobbing Work Order”, Exhibit A, shall be submitted to Engineering. Upon approval of the 0001 Work Order, the Field Engineer will proceed with the upgrading as follows:

- a. Notify the following personnel in writing, as appropriate:

Operations Center Manager



|                               |                                     |  |
|-------------------------------|-------------------------------------|--|
| Effective Date:<br>01/01/2014 | <b>Uprating - Preparatory Steps</b> | Standard Number:<br><b>GS 5500.400</b> |
| Supersedes:<br>N/A            |                                     | Page 2 of 14                           |

Marketing / Sales

Leader Field Operations

Leader Front Line Corrosion and Leakage

- b. Develop a detailed work map or sketch outlining the area to be uprated, indicating:
  1. All points of separation and tie-ins.
  2. Valves that are to be removed, replaced, or added.
  3. Size of mains that are to be replaced prior to uprating.
  4. Taxing District boundaries
  5. Gas flow control fittings, such as Shortstopp, Mueller fittings, etc., that are to be removed, replaced or reinforced.
  6. Branch connections and side taps that are to be removed, replaced or reinforced.
  7. Temporary pressure regulation locations.
  8. District regulator station changes.
- c. Establish target dates for beginning and completing the uprating.
- d. Furnish a copy of the Form C-1445, "Uprate Certificate," (Exhibit B), with the Field Engineer's portion completed to the Leader Field Operations.
- e. Set forth the testing procedure and test pressures, as follows:



|                               |                                     |  |
|-------------------------------|-------------------------------------|--|
| Effective Date:<br>01/01/2014 | <b>Uprating - Preparatory Steps</b> | Standard Number:<br><b>GS 5500.400</b> |
| Supersedes:<br>N/A            |                                     | Page 3 of 14                           |

Minimum Pressure Level Requirements for Uprating Steel Pipelines

| From Present MAOP | To Future MAOP               | Pressure Levels at which System is to be Uprated*  |  |
|-------------------|------------------------------|--|--|
|                   |                              | Pipe with a previous pressure test which qualifies the pipe for the new MAOP (Class location factor times the new MAOP)                        | Pipe without a previous pressure test which qualifies the pipe for the new MAOP (Class location factor times the new MAOP)   |
| L.P.              | I.P.                         | 2 psig, then 10 psig or the MAOP of the I.P. system whichever is lower.  | For I.P. systems less than 1 PSIG – 2 PSIG then 10 PSIG.<br><br>For I.P. System greater than 1 PSIG - 2 psig, then at increments that are equal to 25% of the total pressure increase until 90 PSIG is achieved. |
| L.P.              | M.P.                         | 2 psig, then at increments that are equal to 10 psig or 25% of the total pressure increase, whichever produces the fewer number of increments. | 2 psig, then at increments that are equal to 25% of the total pressure increase until 90 PSIG is achieved.   |
| L.P.              | H.P.<br>(Less Than 100 psig) | 2 psig, then at increments that are equal to 25% of the total pressure increase.   | 2 psig, then at increments that are equal to 25% of the total pressure increase. The total pressure increase is equal to the desired MAOP times the class location factor, but not less than 90 PSIG.            |
| I.P.              | I.P.                         | 2 psig, then 10 psig or the MAOP of the higher pressured I.P. system whichever is lower  | For I.P. systems less than 1 PSIG – 2 PSIG then 10 PSIG.<br><br>For I.P. System greater than 1 PSIG - 2 psig, then at increments that are equal to 25% of the total pressure increase until 90 PSIG is achieved. |
| I.P.              | M.P.                         | At increments that are equal to 10 psig or 25% of the total pressure increase, whichever produces the fewer number of increments.              | At increments that are equal to 25% of the total pressure increase until 90 PSIG is achieved.  |



|                               |                                     |  |
|-------------------------------|-------------------------------------|--|
| Effective Date:<br>01/01/2014 | <b>Uprating - Preparatory Steps</b> | Standard Number:<br><b>GS 5500.400</b> |
| Supersedes:<br>N/A            |                                     | Page 4 of 14                           |

| From Present MAOP | To Future MAOP                                    | Pressure Levels at which System is to be Uprated*  |   |
|-------------------|---|--|---|
|                   |   | Pipe with a previous pressure test which qualifies the pipe for the new MAOP (Class location factor times the new MAOP)            | Pipe without a previous pressure test which qualifies the pipe for the new MAOP (Class location factor times the new MAOP)  |
| I.P.              | H.P.<br>(Less Than 100 psig)                      | At increments that are equal to 25% of the total pressure increase.  | 2 psig, then at increments that are equal to 25% of the total pressure increase. The total pressure increase is equal to the desired MAOP times the class location factor, but not less than 90 PSIG.   |
| M.P.              | H.P.<br>(Less Than 100 psig)                      | At increments that are equal to 10 psig or 25% of the total pressure increase, whichever produces the fewer number of increments.  | At increments that are equal to 10 PSIG or 25% of the total pressure increase, whichever produces the fewer number of increments. The total pressure increase is equal to the desired MAOP times the class location factor, but not less than 90 PSIG.  |
| All               | H.P.<br>(At or above 100 psig and up to 30% SMYS) | At increments that are equal to 10 psig or 25% of the total pressure increase, which ever produces the fewer number of increments. | <p>Take the facility out of service and test in accordance with <a href="#">GS 1500.010</a> "Pressure Testing" or using gas as the test medium, elevate at pressure increments that are equal to 10 psig or 25% of the total required increase to the required test pressure. The total pressure increase is equal to the desired MAOP times the class location factor.</p> <p>Note: If the gas supply pressure is not adequate to achieve the necessary test pressure for the new MAOP and it is not practical to use alternate methods to achieve this level a waiver may be requested from the Vice President - Engineering.</p> |



|                               |                                     |  |
|-------------------------------|-------------------------------------|--|
| Effective Date:<br>01/01/2014 | <b>Uprating - Preparatory Steps</b> | Standard Number:<br><b>GS 5500.400</b> |
| Supersedes:<br>N/A            |                                     | Page 5 of 14                           |

Minimum Pressure Level Requirements for Uprating Plastic Pipelines

| From Present<br><u>MAOP</u> | To Future<br><u>MAOP</u>     | <u>Pressure Levels at which System is to be Uprated*</u>   |  |
|-----------------------------|------------------------------|--|--|
|                             |                              | <u>Pipe with a previous pressure test which qualifies the pipe for the new MAOP (1.5 times the new MAOP)</u>                                   | <u>Pipe without a previous pressure test which qualifies the pipe for the new MAOP (1.5 times the new MAOP)</u>  |
| L.P.                        | I.P.                         | 2 psig, then at increments that are equal to 10 psig or 25% of the total pressure increase, whichever produces the fewer number of increments. | 2 psig, then at increments that are equal to 10 psig or 25% of the total pressure increase, whichever produces the fewer number of increments. The total pressure increase is equal to the desired MAOP times 1.5. Minimum test pressure is 90 PSIG. |
| L.P.                        | M.P.                         |  |  |
| L.P.                        | H.P.<br>(Less Than 100 psig) |  |  |
| I.P.                        | I.P.                         | 2 psig, then 10 psig or the MAOP of the higher pressured I.P. system whichever is lower  | For I.P. systems less than 1 PSIG – 2 PSIG then 10 PSIG.<br><br>For I.P. System greater than 1 PSIG - 2 psig, then at increments that are equal to 25% of the total pressure increase until 90 PSIG is achieved.                                     |
| I.P.                        | M.P.                         | At increments that are equal to 10 psig or 25% of the total pressure increase, whichever produces the fewer number of increments.              | At increments that are equal to 10 psig or 25% of the total pressure increase, whichever produces the fewer number of increments. The total pressure increase is equal to the desired MAOP times 1.5. The minimum test pressure is 90 PSIG           |
| I.P.                        | H.P.<br>(Less Than 100 psig) |  |  |
| M.P.                        | H.P.<br>(Less Than 100 psig) |  |  |



|                               |                                     |  |
|-------------------------------|-------------------------------------|--|
| Effective Date:<br>01/01/2014 | <b>Uprating - Preparatory Steps</b> | Standard Number:<br><b>GS 5500.400</b> |
| Supersedes:<br>N/A            |                                     | Page 6 of 14                           |

| From Present<br><u>MAOP</u> | To Future<br><u>MAOP</u>                              | <u>Pressure Levels at which System is to be Uprated*</u>  |   |
|-----------------------------|---|---|---|
|                             |   | <u>Pipe with a previous pressure test which qualifies the pipe for the new MAOP (1.5 times the new MAOP)</u>                      | <u>Pipe without a previous pressure test which qualifies the pipe for the new MAOP (1.5 times the new MAOP)</u>   |
| All                         | H.P.<br><br>(At or above 100 psig and up to 30% SMYS) | At increments that are equal to 10 psig or 25% of the total pressure increase, whichever produces the fewer number of increments. | Take the facility out of service and test in accordance with GS 1500.010 "Pressure Testing," or; using gas as the test medium, elevate at pressure increments that are equal to 10 psig or 25% of the total pressure increase. The total pressure increase is equal to the desired MAOP times 1.5.<br><br>If the gas supply pressure is not adequate to achieve the necessary test pressure at 150% of the new MAOP and it is not practical to use alternate methods to achieve this level a waiver may be requested from the Vice President - Engineering. |

**\*NOTES:**

- (A) When the piping system is to be uprated at specific pressure increments using natural gas as the test media so that service is maintained to connected customers, normal pressure drop may make it difficult to attain a uniform pressure test level throughout the system. Therefore, uprating should be done during the period when load requirements are minimum, which is usually during the summer months. In making the determination of minimum flow, consideration must be given to any large customers (commercial and industrial) supplied by the system. It may be necessary to coordinate the uprating with scheduled shut down or reduction in the daily gas use of these large customers. The systems shall be checked for leaks at each specified pressure in accordance with the written uprate plan before pressure is raised to the next pressure increment and at the final uprating pressure required to establish the desired MAOP set at the gas source(s).
- (B) In no case shall the maximum uprating test pressure exceed 30 percent of Specified Minimum Yield Strength (SMYS) when using natural gas as the test medium.
- (C) When uprating to a pressure within the M.P. range, it may be desirable to uprate the system to 60 psig even though it may operate at some pressure less than 60 psig.

|                               |                                     |  |
|-------------------------------|-------------------------------------|--|
| Effective Date:<br>01/01/2014 | <b>Uprating - Preparatory Steps</b> | Standard Number:<br><b>GS 5500.400</b> |
| Supersedes:<br>N/A            |                                     | Page 7 of 14                           |

#### 4. WRITTEN PLAN

The Leader Field Operations after receiving notification by the Field Engineer shall be responsible for all aspects of the preparatory work necessary to perform the uprating. Together with the Field Engineer they shall prepare a detailed written plan, which shall be reviewed by Leader Field Engineering. The following preparatory work shall be included in the written plan:

- a. The schedule for installing necessary service regulators.
- b. The schedule for clearance of all open leak orders prior to any pressure increases to be made to the system. Certain Grade 3 and above ground non-hazardous service leaks may be exempted by the Operations Center Manager (or designee).
- c. The schedule for locating, marking, and inspecting all critical valves.
- d. The schedule for locating, marking, and cleaning out of all curb and valve boxes, and line strapping fittings.
- e. The schedule for installation of temporary regulation.
- f. The preparation of Work Orders, as applicable, for Plant work to accomplish the uprating. These Work Orders may include tie-ins, points of separation, main replacements, installation of valves, district regulator changes and measurement changes and related retirements.

Note: The 186-0001 Work Order previously approved shall be used only as a vehicle for establishing a permanent record of the uprating work performed. Any labor and/or material charged to the 186-0001 Work Order shall be transferred to an appropriate Work Order or expense accounts. All related Work Orders involved in the uprate work shall be listed on this reference Work Order.

- g. The preparation of a materials list, showing all items necessary to accomplish the uprating. A copy should be provided to the warehouse.
- h. The schedule of all service line connections uprates and/or service line replacements where required and abandonment of all idle services. Coordinate this work with the Service Department to determine if the service regulators can be installed simultaneously and, thus, eliminate an extra shutdown and minimize inconvenience to the customer.
- i. The schedule for all main line construction as specified by the Work Orders.
- j. For M.P. and H.P. upratings, the schedule for repair or replacement of those parts of the system found to be inadequate for the higher operating pressure (i.e., anchorage on bends and dead ends, mechanical couplings, valves and fittings).
- k. The schedule for the installation or modification of any cathodic protection requirements.

|                               |                                     |  |
|-------------------------------|-------------------------------------|--|
| Effective Date:<br>01/01/2014 | <b>Uprating - Preparatory Steps</b> | Standard Number:<br><b>GS 5500.400</b> |
| Supersedes:<br>N/A            |                                     | Page 8 of 14                           |

- l. The establishment of a pressure control plan to accomplish the uprating by:
  - 1. Incremental pressure increases, as specified by the Field Engineer.
  - 2. Scheduling the necessary temporary and/or permanent pressure regulation modifications or additions.
  - 3. Establishing locations for monitoring pressure during pressure increases.
- m. The provision for system isolation in preparation for the final pressure elevation sequence. (The final system shall be separated from different pressure level systems by cutting out portions of mains. In NO instance may a valve be used for the permanent separation unless it has been blind plated.)
- n. The preparation of a contingency plan in the event of an outage, line breaks, over pressuring, etc. The contingency plan should include identification and function of valves, line stopping fittings, etc. that could be operated in an emergency and alternate source of supply. Non-critical valves shall be checked for accessibility and operability.
- o. Where there are not adequate valves to control an emergency, consideration shall be given to installing valves, line stopping fittings and/or installing line stopping equipment on existing fittings.

**5. REVIEW OF WRITTEN PLAN**

A meeting shall be scheduled to review the total written plan with all personnel involved in carrying out the uprating plan. Each person involved in the uprating will be familiar with the necessary procedures for their area of responsibility in the uprating.

**6. DIS - SERVICE LINE DATA UPDATING**

To ensure that the DIS - Service Line Data is updated to reflect the changes resulting from a pending or completed uprate of an entire or partial system, Exhibit C is provided. The Field Engineer will coordinate with the DIS On-Line team to ensure the changes are made in a timely manner.

DIS On-Line team will coordinate with the DIS – Control (Table) Administrator.

DIS On-Line team is responsible for assigning the System Number which is part of the Main Number.

The DIS – Control (Table) Administrator is responsible for updating the Market System Table with such information as the System Name, Number, Operating Pressure Code, MAOP and MOP.

The Field Engineer is responsible for submitting a Request IT (RIT) to the DIS On-Line team containing a list of each affected customer to be updated as it pertains to Main Number, Operating Pressure Code and Service Regulator Code.

|                               |                                      |  |
|-------------------------------|--------------------------------------|--|
| Effective Date:<br>01/01/2014 | <b>Upgrading - Preparatory Steps</b> | Standard Number:<br><b>GS 5500.400</b> |
| Supersedes:<br>N/A            |                                      | Page 9 of 14                           |

Note: Main Number and Operating Pressure Code can possibly be updated as a group, rather than individually updating each customer record, by updating the associated Network Analysis Study. The Operations Engineer should contact the DIS On-Line team to coordinate this effort.

**7. APPROVALS**

The Manager of Engineering (or equivalent) shall approve the written plan and the reference upgrading job order.





|                               |                                      |  |
|-------------------------------|--------------------------------------|--|
| Effective Date:<br>01/01/2014 | <b>Upgrading - Preparatory Steps</b> | Standard Number:<br><b>GS 5500.400</b> |
| Supersedes:<br>N/A            |                                      | Page 10 of 14                          |

**EXHIBIT A  
(1 of 2)**

Session A - [24 x 80]

File Edit Transfer Appearance Communication Assist Window Help

PrintScreen Copy Paste Send Recv Display Color Map Record Stop Play Quit Clipbrd Index

```

T708                JOB ORDER INQUIRY - GENERAL CAPITAL HEADER                01/26/00

JOB ORDER NUM: 96-0133031-00 *JOB TYPE: 0001 *LOC NUM: 1325 SPEC BUD:
JOB SUMMARY: UPRATE MAOP                JOB STATUS: EX EXECUTED
----- SCHEDULING INFORMATION -----
COMMIT DATE: 07/19/96                TARGET DATE:                START DATE:
SCHED CMT:
PROJECT ID: 96 - 11644                PROJECT NAME: CALDWELL & BOLIVAR UPRATE
RELATED ORDER NUMBERS: WMS JO NUM:                DIS NUM:
GENERATED FROM: WMS JO NUM:                DIS NUM:
----- MISCELLANEOUS INFORMATION -----
NEAREST INTER: -                -                *DIR:                DIST:                FT
ORIG BY: RLUCKYD                CREATE DATE: 03/06/96                SKETCH(Y/N): N *RETIREMENT CODE:
*LAND SERVICE REQUEST CODE: N                *METHOD OF TIE IN: 4 *CO/CONTRACT CODE: A
----- DIG AND BACKFILL/REIMBURSING/CUSTOMER ADVANCES INFORMATION -----
BASIS:                EST AMOUNT:                DATE PYMNT REC:
----- BILL TO INFORMATION -----
NAME:
ADDRESS:
ASSIGNED DATE:

NEXT: _                DATA:
PF10-JO CREAT CMNTS                PF14-COST SUMMARY                PF15-LAND SERVICE                PF16-FACILITY INQ
PF17-PROJECT ID INQ                PF18-GENERAL HEADER                PF21-ECON EVAL
    
```

MA a A 21/008



|                               |                                      |  |
|-------------------------------|--------------------------------------|--|
| Effective Date:<br>01/01/2014 | <b>Upgrading - Preparatory Steps</b> | Standard Number:<br><b>GS 5500.400</b> |
| Supersedes:<br>N/A            |                                      | Page 11 of 14                          |

**EXHIBIT A  
(2 of 2)**

```

T708          JOB ORDER INQUIRY - JO CREATION COMMENTS          01/26/00

JOB ORDER NUM: 96-0133031-00 *JOB TYPE: 0001 *LOC NUM: 1325 SPEC BUD:
JOB SUMMARY: UPRATE MAOP          JOB STATUS: EX EXECUTED

          COMMENTS

NO CHARGES WILL BE MADE THIS JOB ORDER-TO BE USED DOR REFERENCE ONLY.
NOTE:LEAK INSPECTION,REPAIR INFORMATION,TEST CHARTS,MAPS OF AREA
UPRATE CERTIFICATE AND OTHE PERTINENT DATA SHOULD BE ATTACHED TO AND BE
KEPT WITH THE COMPLETION AS PERMANENT RECORD.

NEXT:      DATA:
PF1-HELP  PF2-MAIN MENU  PF3-RETURN  PF4-CODES

MA a          A          21/008
    
```



|                               |                                       |  |
|-------------------------------|---------------------------------------|--|
| Effective Date:<br>01/01/2014 | <h2>Uprating - Preparatory Steps</h2> | Standard Number:<br><b>GS 5500.400</b> |
| Supersedes:<br>N/A            |                                       | Page 12 of 14                          |

**EXHIBIT B  
(1 of 2)**

| UPRATE CERTIFICATE  |  |   |                        |                |                           |                          |  |  |  |            |       |       |               |       |       |               |       |       |                  |       |       |                 |       |       |                    |       |       |      |       |       |             |       |       |                   |  |  |              |       |       |             |       |       |  |  |  |                         |       |       |  |  |  |                        |       |       |  |  |  |
|---|--|---|------------------------|----------------|---------------------------|--------------------------|--|--|--|------------|-------|-------|---------------|-------|-------|---------------|-------|-------|------------------|-------|-------|-----------------|-------|-------|--------------------|-------|-------|------|-------|-------|-------------|-------|-------|-------------------|--|--|--------------|-------|-------|-------------|-------|-------|--|--|--|-------------------------|-------|-------|--|--|--|------------------------|-------|-------|--|--|--|
| Company   |  | District  |                        |                |                           |                          |  |  |  |            |       |       |               |       |       |               |       |       |                  |       |       |                 |       |       |                    |       |       |      |       |       |             |       |       |                   |  |  |              |       |       |             |       |       |  |  |  |                         |       |       |  |  |  |                        |       |       |  |  |  |
| Existing  | Main No. (System No.)                                    | System Name   |                        |                |                           |                          |  |  |  |            |       |       |               |       |       |               |       |       |                  |       |       |                 |       |       |                    |       |       |      |       |       |             |       |       |                   |  |  |              |       |       |             |       |       |  |  |  |                         |       |       |  |  |  |                        |       |       |  |  |  |
|   | MAOP Work Sheet File No.                                 | MAOP  |                        |                |                           |                          |  |  |  |            |       |       |               |       |       |               |       |       |                  |       |       |                 |       |       |                    |       |       |      |       |       |             |       |       |                   |  |  |              |       |       |             |       |       |  |  |  |                         |       |       |  |  |  |                        |       |       |  |  |  |
| Proposed  | Main No. (System No.)                                    | System Name   |                        |                |                           |                          |  |  |  |            |       |       |               |       |       |               |       |       |                  |       |       |                 |       |       |                    |       |       |      |       |       |             |       |       |                   |  |  |              |       |       |             |       |       |  |  |  |                         |       |       |  |  |  |                        |       |       |  |  |  |
|   | MAOP Work Sheet File No.                                 | MAOP  |                        |                |                           |                          |  |  |  |            |       |       |               |       |       |               |       |       |                  |       |       |                 |       |       |                    |       |       |      |       |       |             |       |       |                   |  |  |              |       |       |             |       |       |  |  |  |                         |       |       |  |  |  |                        |       |       |  |  |  |
| Operation Map No(s)   |  | Map(s) Attached<br><input type="checkbox"/> Yes <input type="checkbox"/> No                 | Uprate Work Order No.: |                |                           |                          |  |  |  |            |       |       |               |       |       |               |       |       |                  |       |       |                 |       |       |                    |       |       |      |       |       |             |       |       |                   |  |  |              |       |       |             |       |       |  |  |  |                         |       |       |  |  |  |                        |       |       |  |  |  |
| Does the system contain: <table style="width: 100%; border: none;"> <tr> <td style="text-align: center;">Plastic Pipe</td> <td style="text-align: center;">Cast or Ductile Iron Pipe</td> <td style="text-align: center;">Furnace Butt Welded Pipe</td> </tr> <tr> <td style="text-align: center;"><input type="checkbox"/> Yes <input type="checkbox"/> No</td> <td style="text-align: center;"><input type="checkbox"/> Yes <input type="checkbox"/> No</td> <td style="text-align: center;"><input type="checkbox"/> Yes <input type="checkbox"/> No</td> </tr> </table>   |  |   |                        | Plastic Pipe   | Cast or Ductile Iron Pipe | Furnace Butt Welded Pipe | <input type="checkbox"/> Yes <input type="checkbox"/> No | <input type="checkbox"/> Yes <input type="checkbox"/> No | <input type="checkbox"/> Yes <input type="checkbox"/> No |            |       |       |               |       |       |               |       |       |                  |       |       |                 |       |       |                    |       |       |      |       |       |             |       |       |                   |  |  |              |       |       |             |       |       |  |  |  |                         |       |       |  |  |  |                        |       |       |  |  |  |
| Plastic Pipe  | Cast or Ductile Iron Pipe                                | Furnace Butt Welded Pipe  |                        |                |                           |                          |  |  |  |            |       |       |               |       |       |               |       |       |                  |       |       |                 |       |       |                    |       |       |      |       |       |             |       |       |                   |  |  |              |       |       |             |       |       |  |  |  |                         |       |       |  |  |  |                        |       |       |  |  |  |
| <input type="checkbox"/> Yes <input type="checkbox"/> No  | <input type="checkbox"/> Yes <input type="checkbox"/> No | <input type="checkbox"/> Yes <input type="checkbox"/> No                                    |                        |                |                           |                          |  |  |  |            |       |       |               |       |       |               |       |       |                  |       |       |                 |       |       |                    |       |       |      |       |       |             |       |       |                   |  |  |              |       |       |             |       |       |  |  |  |                         |       |       |  |  |  |                        |       |       |  |  |  |
| Operations Engineer _____   |  |   |                        |                |                           |                          |  |  |  |            |       |       |               |       |       |               |       |       |                  |       |       |                 |       |       |                    |       |       |      |       |       |             |       |       |                   |  |  |              |       |       |             |       |       |  |  |  |                         |       |       |  |  |  |                        |       |       |  |  |  |
| <b>PRE-UPRATE Checklist:</b>  |  | This section shall be completed only for a system taken out of service and pressure tested: |                        |                |                           |                          |  |  |  |            |       |       |               |       |       |               |       |       |                  |       |       |                 |       |       |                    |       |       |      |       |       |             |       |       |                   |  |  |              |       |       |             |       |       |  |  |  |                         |       |       |  |  |  |                        |       |       |  |  |  |
| Leak Survey conducted within past 12 months   | _____ verify by (signature)                              | _____ Test pressure maintained for _____ hrs.   |                        |                |                           |                          |  |  |  |            |       |       |               |       |       |               |       |       |                  |       |       |                 |       |       |                    |       |       |      |       |       |             |       |       |                   |  |  |              |       |       |             |       |       |  |  |  |                         |       |       |  |  |  |                        |       |       |  |  |  |
| Required leak order repaired  | _____  | _____ Test medium   |                        |                |                           |                          |  |  |  |            |       |       |               |       |       |               |       |       |                  |       |       |                 |       |       |                    |       |       |      |       |       |             |       |       |                   |  |  |              |       |       |             |       |       |  |  |  |                         |       |       |  |  |  |                        |       |       |  |  |  |
| Cathodic protection system reviewed   | _____  | _____ Service regulators upgraded   |                        |                |                           |                          |  |  |  |            |       |       |               |       |       |               |       |       |                  |       |       |                 |       |       |                    |       |       |      |       |       |             |       |       |                   |  |  |              |       |       |             |       |       |  |  |  |                         |       |       |  |  |  |                        |       |       |  |  |  |
| Required Service Regulators installed   | _____  | Reverse side shall be completed for a system maintained in service                          |                        |                |                           |                          |  |  |  |            |       |       |               |       |       |               |       |       |                  |       |       |                 |       |       |                    |       |       |      |       |       |             |       |       |                   |  |  |              |       |       |             |       |       |  |  |  |                         |       |       |  |  |  |                        |       |       |  |  |  |
| <b>POST-UPRATE Checklist:</b> <table style="width: 100%; border: none;"> <thead> <tr> <th></th> <th style="text-align: center;"><u>Updated</u></th> <th style="text-align: center;"><u>Not Affected</u></th> <th></th> <th style="text-align: center;"><u>Updated</u></th> <th style="text-align: center;"><u>Not Affected</u></th> </tr> </thead> <tbody> <tr> <td>DIS Tables</td> <td>_____</td> <td>_____</td> <td>Network Model</td> <td>_____</td> <td>_____</td> </tr> <tr> <td>Market/System</td> <td>_____</td> <td>_____</td> <td>Reg. - Inv. Card</td> <td>_____</td> <td>_____</td> </tr> <tr> <td>Taxing District</td> <td>_____</td> <td>_____</td> <td>Critical Valve Map</td> <td>_____</td> <td>_____</td> </tr> <tr> <td>Town</td> <td>_____</td> <td>_____</td> <td>MAOP Record</td> <td>_____</td> <td>_____</td> </tr> <tr> <td>Service Line Data</td> <td></td> <td></td> <td>Peak Day Map</td> <td>_____</td> <td>_____</td> </tr> <tr> <td>Main Number</td> <td>_____</td> <td>_____</td> <td></td> <td></td> <td></td> </tr> <tr> <td>Operating Pressure Code</td> <td>_____</td> <td>_____</td> <td></td> <td></td> <td></td> </tr> <tr> <td>Service Regulator Code</td> <td>_____</td> <td>_____</td> <td></td> <td></td> <td></td> </tr> </tbody> </table> |  |   |                        |                | <u>Updated</u>            | <u>Not Affected</u>      |  | <u>Updated</u>   | <u>Not Affected</u>                                      | DIS Tables | _____ | _____ | Network Model | _____ | _____ | Market/System | _____ | _____ | Reg. - Inv. Card | _____ | _____ | Taxing District | _____ | _____ | Critical Valve Map | _____ | _____ | Town | _____ | _____ | MAOP Record | _____ | _____ | Service Line Data |  |  | Peak Day Map | _____ | _____ | Main Number | _____ | _____ |  |  |  | Operating Pressure Code | _____ | _____ |  |  |  | Service Regulator Code | _____ | _____ |  |  |  |
|   | <u>Updated</u>   | <u>Not Affected</u>   |                        | <u>Updated</u> | <u>Not Affected</u>       |                          |  |  |  |            |       |       |               |       |       |               |       |       |                  |       |       |                 |       |       |                    |       |       |      |       |       |             |       |       |                   |  |  |              |       |       |             |       |       |  |  |  |                         |       |       |  |  |  |                        |       |       |  |  |  |
| DIS Tables  | _____  | _____   | Network Model          | _____          | _____                     |                          |  |  |  |            |       |       |               |       |       |               |       |       |                  |       |       |                 |       |       |                    |       |       |      |       |       |             |       |       |                   |  |  |              |       |       |             |       |       |  |  |  |                         |       |       |  |  |  |                        |       |       |  |  |  |
| Market/System   | _____  | _____   | Reg. - Inv. Card       | _____          | _____                     |                          |  |  |  |            |       |       |               |       |       |               |       |       |                  |       |       |                 |       |       |                    |       |       |      |       |       |             |       |       |                   |  |  |              |       |       |             |       |       |  |  |  |                         |       |       |  |  |  |                        |       |       |  |  |  |
| Taxing District   | _____  | _____   | Critical Valve Map     | _____          | _____                     |                          |  |  |  |            |       |       |               |       |       |               |       |       |                  |       |       |                 |       |       |                    |       |       |      |       |       |             |       |       |                   |  |  |              |       |       |             |       |       |  |  |  |                         |       |       |  |  |  |                        |       |       |  |  |  |
| Town  | _____  | _____   | MAOP Record            | _____          | _____                     |                          |  |  |  |            |       |       |               |       |       |               |       |       |                  |       |       |                 |       |       |                    |       |       |      |       |       |             |       |       |                   |  |  |              |       |       |             |       |       |  |  |  |                         |       |       |  |  |  |                        |       |       |  |  |  |
| Service Line Data   |  |   | Peak Day Map           | _____          | _____                     |                          |  |  |  |            |       |       |               |       |       |               |       |       |                  |       |       |                 |       |       |                    |       |       |      |       |       |             |       |       |                   |  |  |              |       |       |             |       |       |  |  |  |                         |       |       |  |  |  |                        |       |       |  |  |  |
| Main Number   | _____  | _____   |                        |                |                           |                          |  |  |  |            |       |       |               |       |       |               |       |       |                  |       |       |                 |       |       |                    |       |       |      |       |       |             |       |       |                   |  |  |              |       |       |             |       |       |  |  |  |                         |       |       |  |  |  |                        |       |       |  |  |  |
| Operating Pressure Code   | _____  | _____   |                        |                |                           |                          |  |  |  |            |       |       |               |       |       |               |       |       |                  |       |       |                 |       |       |                    |       |       |      |       |       |             |       |       |                   |  |  |              |       |       |             |       |       |  |  |  |                         |       |       |  |  |  |                        |       |       |  |  |  |
| Service Regulator Code  | _____  | _____   |                        |                |                           |                          |  |  |  |            |       |       |               |       |       |               |       |       |                  |       |       |                 |       |       |                    |       |       |      |       |       |             |       |       |                   |  |  |              |       |       |             |       |       |  |  |  |                         |       |       |  |  |  |                        |       |       |  |  |  |





|                               |  |  |
|-------------------------------|--|--|
| Effective Date:<br>01/01/2014 | <h2>Upgrading - Preparatory Steps</h2> | Standard Number:<br><b>GS 5500.400</b> |
| Supersedes:<br>N/A            |  | Page 14 of 14                          |

**EXHIBIT C**

| Type Update Action  | DIS Control Table Administrator |                            | DIS Customer SID Information Update |                     |                        |
|---|---------------------------------|----------------------------|-------------------------------------|---------------------|------------------------|
|   | Assign System No.               | Update Market/System Table | Main Number                         | Operating Pres Code | Service Regulator Code |
| Entire HP System Upgraded to HP - No Connection to Another System                       |                                 | (1)                        |                                     |                     |                        |
| Entire MP System Upgraded to MP - No Connection to Another System                       |                                 | (1)                        |                                     |                     |                        |
| Entire IP System Upgraded to IP - No Connection to Another System                       |                                 | (1)                        |                                     |                     |                        |
| Entire HP System Upgraded to HP - Connected to Another System                           |                                 | (2)                        | X                                   |                     |                        |
| Entire MP System Upgraded to MP - Connected to Another System                           |                                 | (2)                        | X                                   |                     |                        |
| Entire IP System Upgraded to IP - Connected to Another System                           |                                 | (2)                        | X                                   |                     |                        |
| Entire IP System Upgraded to MP - Just Raise Pressure - No Connection to Another System |                                 | (1)                        |                                     | X                   | (5)                    |
| Entire MP System Upgraded to HP - Just Raise Pressure - No Connection to Another System |                                 | (1)                        |                                     | X                   | X                      |
| Entire MP System Upgraded to MP - Connected to Existing MP System                       |                                 | (2)                        | X                                   |                     | (5)                    |
| Entire MP System Upgraded to HP - Connected to Existing HP System                       |                                 | (2)                        | X                                   | X                   | X                      |
| Part IP System Upgraded to MP - Create a New MP System                                  | X                               | X                          | X                                   | X                   | (5)                    |
| Part MP System Upgraded to HP - Create a New HP System                                  | X                               | X                          | X                                   | X                   | X                      |
| Part IP System Upgraded to MP - Connected to Existing MP System                         |                                 |                            | X                                   | X                   | (5)                    |
| Part LP System Upgraded to IP or MP - Create a New IP or MP System                      | (3)                             | (3)                        | (4)                                 | (4)                 | (4)                    |
| Entire LP System Upgraded to IP or MP - No Connection to an Existing System             |                                 | (3)                        |                                     | (4)                 | (4)                    |
| Entire LP System Upgraded to IP or MP - Connect to Existing System                      |                                 | (2)                        | (4)                                 | (4)                 | (4)                    |
| Part LP System Upgraded to IP or MP - Connect to Existing System                        |                                 |                            | (4)                                 | (4)                 | (4)                    |
| Part HP System Upgraded to HP - Connected to an Existing System                         |                                 |                            | X                                   | (4)                 | (4)                    |

(1) Change MR0P  
 (2) Delete System Number  
 (3) Must be done prior to working any orders to install regulators and updating any SID information on DIS. This should be done just before starting the work.  
 (4) All these fields should be updated at the same time - if not, may not be able to enter Regulator Code.  
 (5) If regulator change required



**Distribution Operations**

**Gas Standard**

|                               |  |  |
|-------------------------------|--|--|
| Effective Date:<br>01/01/2014 | <b>Uprating – Completion of Pressure Elevation</b> | Standard Number:<br><b>GS 5500.500</b> |
| Supersedes:<br>N/A            |  | Page 1 of 3                            |

Companies Affected:

|                                 |   |   |
|---------------------------------|---|---|
| <input type="checkbox"/> NIPSCO | <input type="checkbox"/> CGV            | <input checked="" type="checkbox"/> CMD |
|                                 | <input checked="" type="checkbox"/> CKY | <input checked="" type="checkbox"/> COH |
|                                 | <input checked="" type="checkbox"/> CMA | <input checked="" type="checkbox"/> CPA |

**REFERENCE** 49 CFR Part 192 - Subpart K

**1. SCOPE**

This standard describes the procedures and responsibilities to conduct an uprating of a pipeline to a new higher MAOP. The standard also addresses procedures and responsibilities to complete paperwork and record management including Service Line Data updates.

**2. NOTIFICATION**

The Field Operations and/or Construction Leaders shall notify the Service, Customer Contact, Marketing and Dispatching personnel and all leaders in the operating area when pressure increases are scheduled and completed.

**3. RESPONSIBILITIES**

**3.1 Field Operations and/or Construction Leaders**

The Field Operations and/or Construction Leader's responsibility during and after elevating pressure is as follows:

- a. Elevate pressure as prescribed in the written plan. A pressure recording gauge shall be used to record pressure of all tests.
- b. During the first pressure increase, check for pressure increases in adjacent distribution systems which may result from unknown main tie-ins.
- c. A leakage survey of mains and service lines shall be started immediately after each elevation of pressure and completed before the next pressure elevation. All leaks, except those Grade 3 leaks and/or above ground non-hazardous service leaks exempted by the Operations Center Manager (or designee), shall be repaired at each pressure level prior to continuing to the next pressure level. The pressure may be held at the established level while repairing leaks. Grade 3 leaks or above ground non-hazardous service leaks not repaired shall be monitored during successive pressure increases.
- d. Between 7 and 15 days after the uprating is completed an additional leakage survey at the new MAOP shall be made on both mains and service

*This document is considered CONTROLLED only when viewed electronically on the Company's intranet. Printed or other electronic copies may not be current, and the intranet version should be used to verify.*



**Distribution Operations**

**Gas Standard**

|                               |   |  |
|-------------------------------|---|--|
| Effective Date:<br>01/01/2014 | <b>Upgrading – Completion of Pressure Elevation</b> | Standard Number:<br><b>GS 5500.500</b> |
| Supersedes:<br>N/A            |   | Page 2 of 3                            |

lines up to the Meter Set Assembly or regulator setting. Any leaks found shall be classified and cleared in accordance with Gas Standard Series 1714 "Leakage".

- e. A record of each leakage survey shall be made and reported on a job order associated with the upgrading
- f. Complete the 0001 and related Work Orders in accordance with GS 2810.020(CG) "Work Order Completion Reports."
- g. Prepare a new Form GS 1660.020-01, "MAOP Worksheet," secure the Field Engineer approval, and file in accordance with GS 1660.020 "Documentation of Maximum Allowable Operating Pressure (MAOP)." Copies of the 0001 Work Order, leak inspection repair information, test charts, maps, uprate certificate and other pertinent data shall be included.
- h. Assure that WMS Report No. WLB4210 "Regulator Station Inventory Record Card," is revised for all affected permanent Plant pressure regulation stations and GMB stations in accordance with GS 1750.810(CG) "Records and Reports for Regulation."

**4. DIS - SERVICE LINE DATA UPDATING**

To ensure that the DIS - Service Line Data is updated including the leak survey information to reflect the changes resulting from a pending or completed uprate of an entire or partial system, Exhibit A is provided. The Field Engineer will coordinate with the DIS On-Line Team to ensure the changes are made in a timely manner.

The DIS On-Line Team is responsible for assigning the System Number which is part of the Main Number.

The DIS – Control (Table) Administrator is responsible for upgrading the Market System Table with such information as the System Name, Number, Operating Pressure Code, MAOP and MOP.

The Field Engineer is responsible for submitting a Request IT (RIT) to the DIS On-Line Team containing a list of each affected customer to be updated as it pertains to Main Number, Operating Pressure Code and Service Regulator Code.

Note: Main Number and Operating Pressure Code can possibly be updated as a group, rather than individually updating each customer record, by updating the Network Analysis Study. The Field Engineer should contact the DIS On-Line Team to coordinate this effort.



**Gas Standard**

|                               |  |  |
|-------------------------------|--|--|
| Effective Date:<br>01/01/2014 | <b>Uprating – Completion of Pressure Elevation</b> | Standard Number:<br><b>GS 5500.500</b> |
| Supersedes:<br>N/A            |  | Page 3 of 3                            |

**EXHIBIT A**

| Type Update Action   | DIS Control Table Administrator Assign System No. | Update Market/System Table | DIS Customer SLD Information Main Number | Operating Pres Code | Service Regulator Code |
|--|---|----------------------------|--|---------------------|------------------------|
| Entire HP System Updated to HP - No Connection to Another System                       |   | (1)                        |  |                     |                        |
| Entire MP System Updated to MP - No Connection to Another System                       |   | (1)                        |  | X                   | (5)                    |
| Entire IP System Updated to IP - No Connection to Another System                       |   | (1)                        |  | X                   | (5)                    |
| Entire HP System Updated to HP - Connected to Another System                           |   | (2)                        | X  | X                   | (5)                    |
| Entire MP System Updated to MP - Connected to Another System                           |   | (2)                        | X  | X                   | (5)                    |
| Entire IP System Updated to IP - Connected to Another System                           |   | (2)                        | X  | X                   | (5)                    |
| Entire IP System Updated to MP - Just Raise Pressure - No Connection to Another System |   | (1)                        |  | X                   | (5)                    |
| Entire MP System Updated to HP - Just Raise Pressure - No Connection to Another System |   | (1)                        |  | X                   | (5)                    |
| Entire MP System Updated to MP - Connected to Existing MP System                       |   | (2)                        | X  | X                   | (5)                    |
| Entire HP System Updated to HP - Connected to Existing HP System                       |   | (2)                        | X  | X                   | (5)                    |
| Part IP System Updated to HP - Create a New HP System                                  | X   | X                          | X  | X                   | (5)                    |
| Part MP System Updated to HP - Create a New HP System                                  | X   | X                          | X  | X                   | (5)                    |
| Part IP System Updated to MP - Connected to Existing MP System                         | (3)   | (3)                        | (4)                                      | (4)                 | (4)                    |
| Part LP System Updated to IP or MP - Create a New IP or MP System                      |   | (3)                        | (4)                                      | (4)                 | (4)                    |
| Entire LP System Updated to IP or MP - No Connection to an Existing System             |   | (3)                        | (4)                                      | (4)                 | (4)                    |
| Entire IP System Updated to IP or MP - Connect to Existing System                      |   | (2)                        | (4)                                      | (4)                 | (4)                    |
| Part LP System Updated to IP or MP - Connect to Existing System                        |   | (4)                        | (4)                                      | (4)                 | (4)                    |
| Part HP System Updated to HP - Connected to an Existing System                         |   | X                          | X  | X                   | (4)                    |

(1) Change MAOP  
 (2) Delete System Number  
 (3) Must be done prior to working any orders to install regulators and updating any SLD information on DIS. This should be done just before starting the work.  
 (4) All these fields should be updated at the same time - if not, may not be able to enter Regulator Code.  
 (5) If regulator change required





Distribution Operations

|                               |  |   |
|-------------------------------|--|---|
| Effective Date:<br>09/10/1990 | <b>Gas Facilities on Customer Premises</b> | Standard Number:<br><b>GS 6000.010(CG)</b><br>P&P 700-3 |
| Supersedes:<br>N/A            |  | Page 1 of 7   |

Companies Affected:

|                                 |   |   |
|---------------------------------|---|---|
| <input type="checkbox"/> NIPSCO | <input checked="" type="checkbox"/> CGV | <input checked="" type="checkbox"/> CMD |
|                                 | <input checked="" type="checkbox"/> CKY | <input checked="" type="checkbox"/> COH |
|                                 | <input type="checkbox"/> CMA            | <input checked="" type="checkbox"/> CPA |

**REFERENCE** Code of Federal Regulations - Title 24 - Part 3280  
 Code of Federal Regulations - Title 49 - Part 192  
 National Fuel Gas Code (NFPA 54 - ANSI Z223.1)  
 NFPA 501A

**1. GENERAL**

This procedure provides for the installation, inspection and testing of customer service lines and house lines and the installation and venting of customer appliances.

Gas facilities installed on a customer's premises by Company personnel shall be installed in compliance with the standards and codes identified in this Gas Standard.

Gas facilities installed on a customer's premises by other than Company personnel shall be installed with materials and workmanship which meet the requirements specified in this Gas Standard and shall be subject to inspection or testing by the Company before the Company will establish service.

At customer's request, Company personnel may give advice in the installation of gas facilities by others; however, the Company will not assume responsibility for maintenance of, or for any imperfect material or faulty workmanship associated with, such facilities.

**2. CUSTOMER SERVICE LINE**

The customer service line consists of that part of the service line from the curb valve or property line to the meter set assembly regard-less of ownership. Unless state tariff requires otherwise this portion of the service line is installed by the customer.

Customer owned service lines shall be sized, installed, inspected and tested in accordance with CDC's - "Standards For Gas Piping on Customers' Premises," Exhibit A.

Company owned customer service lines are installed and tested according to the Series 3020 of Gas Standards and [GS 1500.010](#) or [GS 1500.010\(OH\)](#) "Pressure Testing," respectively.

*This document is considered CONTROLLED only when viewed electronically on the Company's intranet. Printed or other electronic copies may not be current, and the intranet version should be used to verify.*



Distribution Operations

|                               |  |   |
|-------------------------------|--|---|
| Effective Date:<br>09/10/1990 | <b>Gas Facilities on Customer<br/>Premises</b> | Standard Number:<br><b>GS 6000.010(CG)</b><br>P&P 700-3 |
| Supersedes:<br>N/A            |  | Page 2 of 7   |

**3. METER SET ASSEMBLIES**

The Company will furnish and connect a meter for each customer. The meter remains the property of the Company.

When the customer installs the customer service line, the meter set assembly shall be installed in accordance with CDC's "Standards For Gas Piping on Customers' Premises," Exhibit A.

When the Company installs the customer service line, the meter set assembly shall be installed in accordance with CDC's "Standards For Gas Piping on Customers' Premises," Exhibit A, and/or other applicable gas standards.

**4. CUSTOMER HOUSE LINES**

Customer house lines shall be sized, installed, inspected and tested in accordance with the National Fuel Gas Code, Exhibit B.

**5. APPLIANCE INSTALLATION AND VENTING**

The installation and venting of appliances on customers' premises shall be done in accordance with the National Fuel Gas Code, Exhibit B.

**6. MOBILE HOME HOUSE PIPING SYSTEM**

The installation of mobile home house piping shall be done in accordance with Title 24 - Part 3280, "Manufactured Home Construction and Safety Standards" - Subpart H, "Heating, Cooling and Fuel Burning Systems," Exhibit C.

**7. MOBILE HOME PARKS**

Customer owned piping systems within mobile home parks shall be designed and constructed in accordance with NFPA 501 A, "Fire Safety Criteria for Manufactured Home Installations, Sites and Communities," Exhibit D.

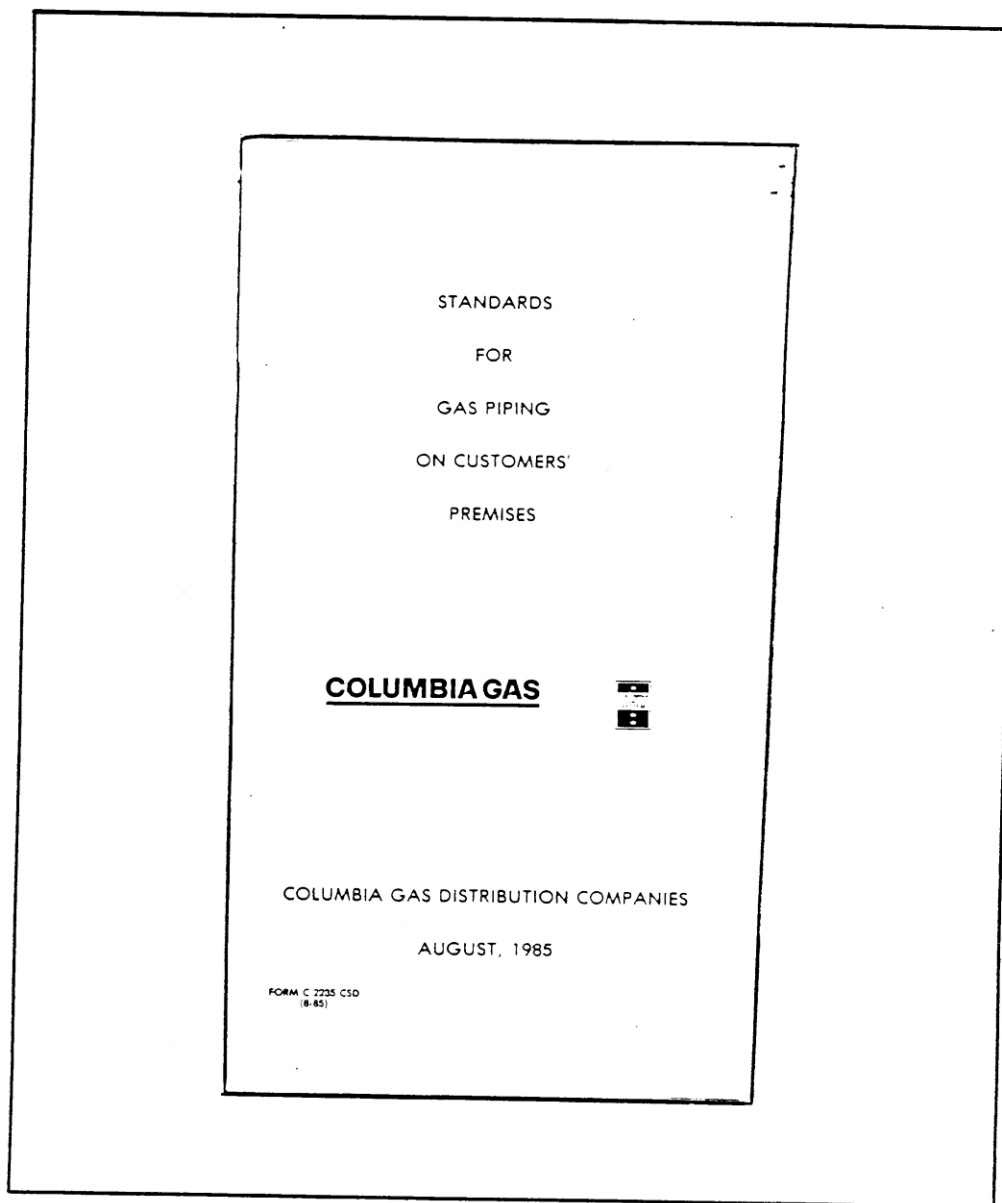


**Gas Standard**

Distribution Operations

|                               |  |   |
|-------------------------------|--|---|
| Effective Date:<br>09/10/1990 | <b>Gas Facilities on Customer<br/>Premises</b> | Standard Number:<br><b>GS 6000.010(CG)</b><br>P&P 700-3 |
| Supersedes:<br>N/A            |  | Page 3 of 7   |

**EXHIBIT A**



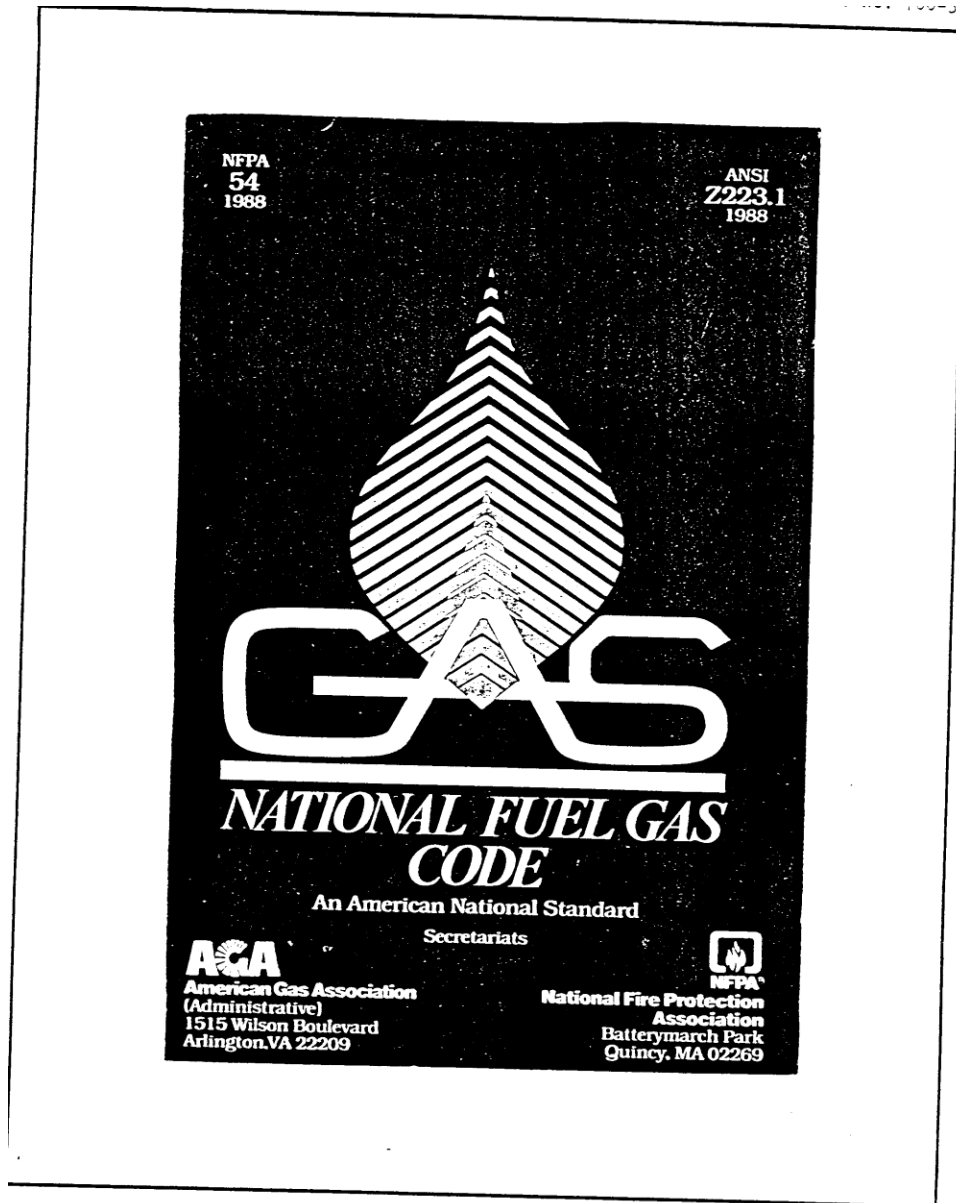


**Gas Standard**

Distribution Operations

|                               |  |   |
|-------------------------------|--|---|
| Effective Date:<br>09/10/1990 | <b>Gas Facilities on Customer Premises</b> | Standard Number:<br><b>GS 6000.010(CG)</b><br>P&P 700-3 |
| Supersedes:<br>N/A            |  | Page 4 of 7   |

**EXHIBIT B**



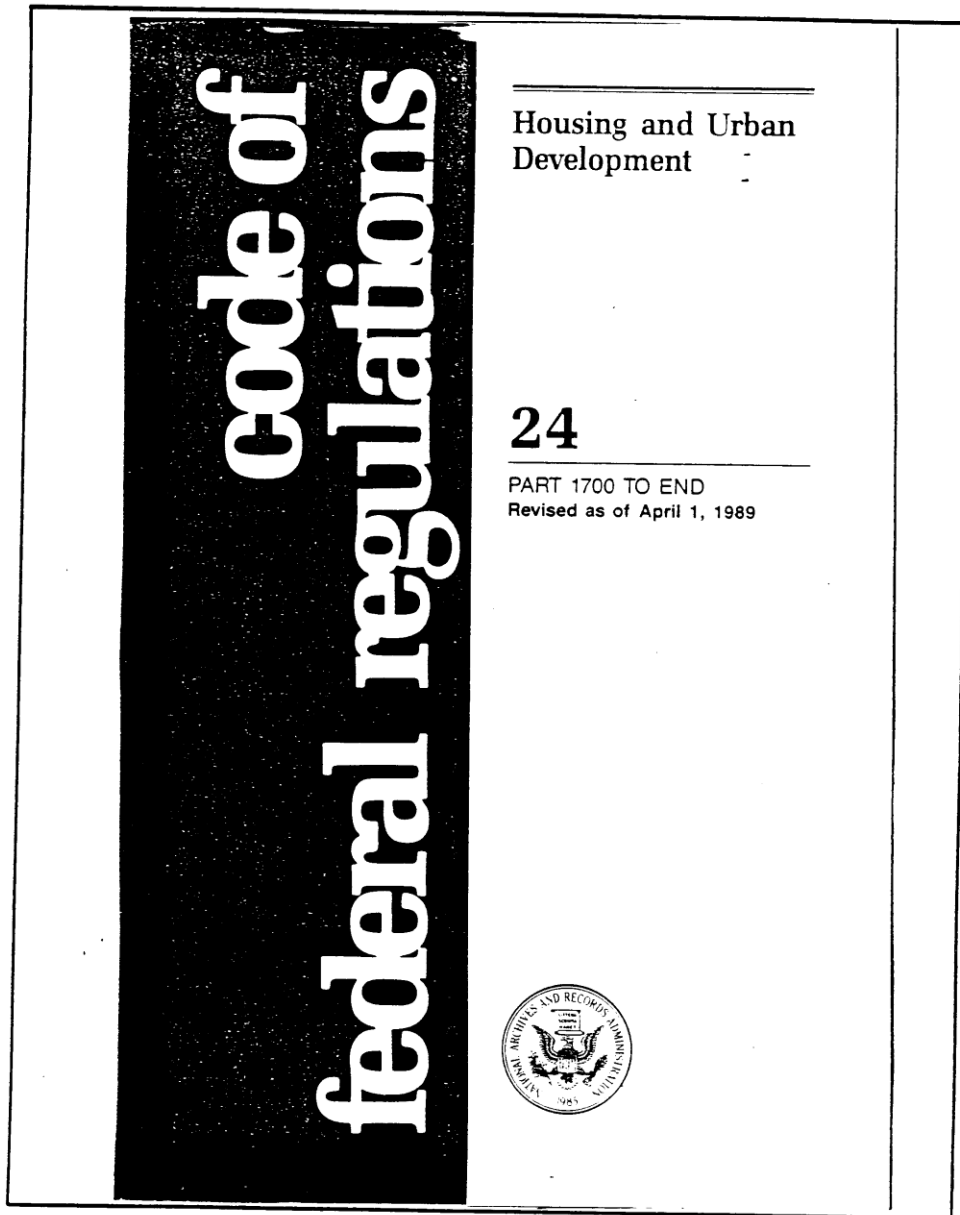


**Gas Standard**

Distribution Operations

|                               |  |   |
|-------------------------------|--|---|
| Effective Date:<br>09/10/1990 | <b>Gas Facilities on Customer Premises</b> | Standard Number:<br><b>GS 6000.010(CG)</b><br>P&P 700-3 |
| Supersedes:<br>N/A            |  | Page 5 of 7   |

**EXHIBIT C  
(1 of 2)**





Distribution Operations

Gas Standard

|                               |  |   |
|-------------------------------|--|---|
| Effective Date:<br>09/10/1990 | <b>Gas Facilities on Customer Premises</b> | Standard Number:<br><b>GS 6000.010(CG)</b><br>P&P 700-3 |
| Supersedes:<br>N/A            |  | Page 6 of 7   |

**EXHIBIT C**  
**(2 of 2)**

| Section   | Description                                  | Reference  |  |
|---|--|--|--|
| PART 3280—MANUFACTURED HOME CONSTRUCTION AND SAFETY STANDARDS | 3280 101 Scope                               | Office of Asst. Sec. for Housing, HUD<br>2280 714 Analyzers, cooling<br>2280 715 Circulating air systems<br>3280 801 Electrical systems<br>3280 802 Definitions<br>3280 803 Power supply<br>3280 804 Gas piping<br>3280 805 Interconnecting means and branch circuit<br>3280 806 Branch circuits required<br>3280 807 Recreational outlets<br>3280 808 Wiring methods and materials<br>3280 809 Grounding<br>3280 810 Calculations<br>3280 811 Gas piping<br>3280 812 Outdoor units, fixtures, air con<br>3280 813 Venting equipment, etc.<br>3280 814 Gas piping<br>3280 815 Polarization<br>3280 816 Examination of equipment for safety<br>3280 817<br>3280 818<br>3280 819<br>3280 901 Scope<br>3280 902 Definitions<br>3280 903 General requirements for design<br>3280 904 Structure to withstand transport<br>3280 905<br>3280 906<br>3280 907<br>3280 908<br>3280 909<br>3280 910<br>3280 911<br>3280 912<br>3280 913<br>3280 914<br>3280 915<br>3280 916<br>3280 917<br>3280 918<br>3280 919<br>3280 920<br>3280 921<br>3280 922<br>3280 923<br>3280 924<br>3280 925<br>3280 926<br>3280 927<br>3280 928<br>3280 929<br>3280 930<br>3280 931<br>3280 932<br>3280 933<br>3280 934<br>3280 935<br>3280 936<br>3280 937<br>3280 938<br>3280 939<br>3280 940<br>3280 941<br>3280 942<br>3280 943<br>3280 944<br>3280 945<br>3280 946<br>3280 947<br>3280 948<br>3280 949<br>3280 950<br>3280 951<br>3280 952<br>3280 953<br>3280 954<br>3280 955<br>3280 956<br>3280 957<br>3280 958<br>3280 959<br>3280 960<br>3280 961<br>3280 962<br>3280 963<br>3280 964<br>3280 965<br>3280 966<br>3280 967<br>3280 968<br>3280 969<br>3280 970<br>3280 971<br>3280 972<br>3280 973<br>3280 974<br>3280 975<br>3280 976<br>3280 977<br>3280 978<br>3280 979<br>3280 980<br>3280 981<br>3280 982<br>3280 983<br>3280 984<br>3280 985<br>3280 986<br>3280 987<br>3280 988<br>3280 989<br>3280 990<br>3280 991<br>3280 992<br>3280 993<br>3280 994<br>3280 995<br>3280 996<br>3280 997<br>3280 998<br>3280 999<br>3280 1000 |  |
|   | 3280 102 Definitions                         |  |  |
|   | 3280 103 Light and ventilation               |  |  |
|   | 3280 104 Ceiling height                      |  |  |
|   | 3280 105 Exit facilities                     |  |  |
|   | 3280 106 Exit facilities, excess windows and |  |  |
|   | 3280 107 Interlock safety                    |  |  |
|   | 3280 108 Interlock passage                   |  |  |
|   | 3280 109 Space planning                      |  |  |
|   | 3280 110 Minimum clearances                  |  |  |
|   | 3280 111 Minimum clearances                  |  |  |
|   | 3280 112 Toilet compartments                 |  |  |
|   | 3280 113 Hallways                            |  |  |
|   | 3280 114 Open and glazed openings            |  |  |
|   | 3280 201 Scope                               |  |  |
| 3280 202 Definitions  |  |  |  |
| 3280 203 Protective requirements and fire                     |  |  |  |
| 3280 204 Kitchen cabinet protection                           |  |  |  |
| 3280 205 Fireproofing   |  |  |  |
| 3280 206 Requirements for foam plastic                        |  |  |  |
| 3280 207 Insulation materials                                 |  |  |  |
| 3280 208 Fire testing   |  |  |  |
| 3280 209 Fire testing   |  |  |  |
| 3280 301 Scope  |  |  |  |
| 3280 302 Definitions  |  |  |  |
| 3280 303 Minimum standards                                    |  |  |  |
| 3280 304 Fuel supply systems                                  |  |  |  |
| 3280 305 Gas piping systems                                   |  |  |  |
| 3280 306 Oil piping systems                                   |  |  |  |
| 3280 307 Heat producing appliances                            |  |  |  |
| 3280 308 Fuel storage   |  |  |  |
| 3280 309 Ventilation  |  |  |  |
| 3280 310 Ventilation of appliances                            |  |  |  |
| 3280 311 Insulation   |  |  |  |
| 3280 312 Accessibility  |  |  |  |
| 3280 401 Structural load tests                                |  |  |  |
| 3280 501 Scope  |  |  |  |
| 3280 502 Definitions  |  |  |  |
| 3280 503 General requirements                                 |  |  |  |
| 3280 504 Materials  |  |  |  |
| 3280 505 Joints and connections                               |  |  |  |
| 3280 506 Traps and cleanouts                                  |  |  |  |
| 3280 507 Plumbing fixtures                                    |  |  |  |
| 3280 508 Water distribution systems                           |  |  |  |
| 3280 509 Drainage systems                                     |  |  |  |
| 3280 510 Tests and venting                                    |  |  |  |
| 3280 511 Tests and inspection                                 |  |  |  |
| 3280 512 Tests and inspection                                 |  |  |  |
| 3280 601 Scope  |  |  |  |
| 3280 602 Definitions  |  |  |  |
| 3280 603 General requirements                                 |  |  |  |
| 3280 604 Materials  |  |  |  |
| 3280 605 Joints and connections                               |  |  |  |
| 3280 606 Traps and cleanouts                                  |  |  |  |
| 3280 607 Plumbing fixtures                                    |  |  |  |
| 3280 608 Water distribution systems                           |  |  |  |
| 3280 609 Drainage systems                                     |  |  |  |
| 3280 610 Tests and venting                                    |  |  |  |
| 3280 611 Tests and inspection                                 |  |  |  |
| 3280 612 Tests and inspection                                 |  |  |  |
| 3280 701 Scope  |  |  |  |
| 3280 702 Definitions  |  |  |  |
| 3280 703 Minimum standards                                    |  |  |  |
| 3280 704 Fuel supply systems                                  |  |  |  |
| 3280 705 Gas piping systems                                   |  |  |  |
| 3280 706 Oil piping systems                                   |  |  |  |
| 3280 707 Heat producing appliances                            |  |  |  |
| 3280 708 Fuel storage   |  |  |  |
| 3280 709 Ventilation  |  |  |  |
| 3280 710 Ventilation of appliances                            |  |  |  |
| 3280 711 Insulation   |  |  |  |
| 3280 712 Accessibility  |  |  |  |
| 3280 801 Scope  |  |  |  |
| 3280 802 Definitions  |  |  |  |
| 3280 803 General requirements                                 |  |  |  |
| 3280 804 Materials  |  |  |  |
| 3280 805 Joints and connections                               |  |  |  |
| 3280 806 Traps and cleanouts                                  |  |  |  |
| 3280 807 Plumbing fixtures                                    |  |  |  |
| 3280 808 Water distribution systems                           |  |  |  |
| 3280 809 Drainage systems                                     |  |  |  |
| 3280 810 Tests and venting                                    |  |  |  |
| 3280 811 Tests and inspection                                 |  |  |  |
| 3280 812 Tests and inspection                                 |  |  |  |
| 3280 901 Scope  |  |  |  |
| 3280 902 Definitions  |  |  |  |
| 3280 903 General requirements                                 |  |  |  |
| 3280 904 Materials  |  |  |  |
| 3280 905 Joints and connections                               |  |  |  |
| 3280 906 Traps and cleanouts                                  |  |  |  |
| 3280 907 Plumbing fixtures                                    |  |  |  |
| 3280 908 Water distribution systems                           |  |  |  |
| 3280 909 Drainage systems                                     |  |  |  |
| 3280 910 Tests and venting                                    |  |  |  |
| 3280 911 Tests and inspection                                 |  |  |  |
| 3280 912 Tests and inspection                                 |  |  |  |
| 3280 1001 Scope   |  |  |  |
| 3280 1002 Definitions   |  |  |  |
| 3280 1003 General requirements                                |  |  |  |
| 3280 1004 Materials   |  |  |  |
| 3280 1005 Joints and connections                              |  |  |  |
| 3280 1006 Traps and cleanouts                                 |  |  |  |
| 3280 1007 Plumbing fixtures                                   |  |  |  |
| 3280 1008 Water distribution systems                          |  |  |  |
| 3280 1009 Drainage systems                                    |  |  |  |
| 3280 1010 Tests and venting                                   |  |  |  |
| 3280 1011 Tests and inspection                                |  |  |  |
| 3280 1012 Tests and inspection                                |  |  |  |



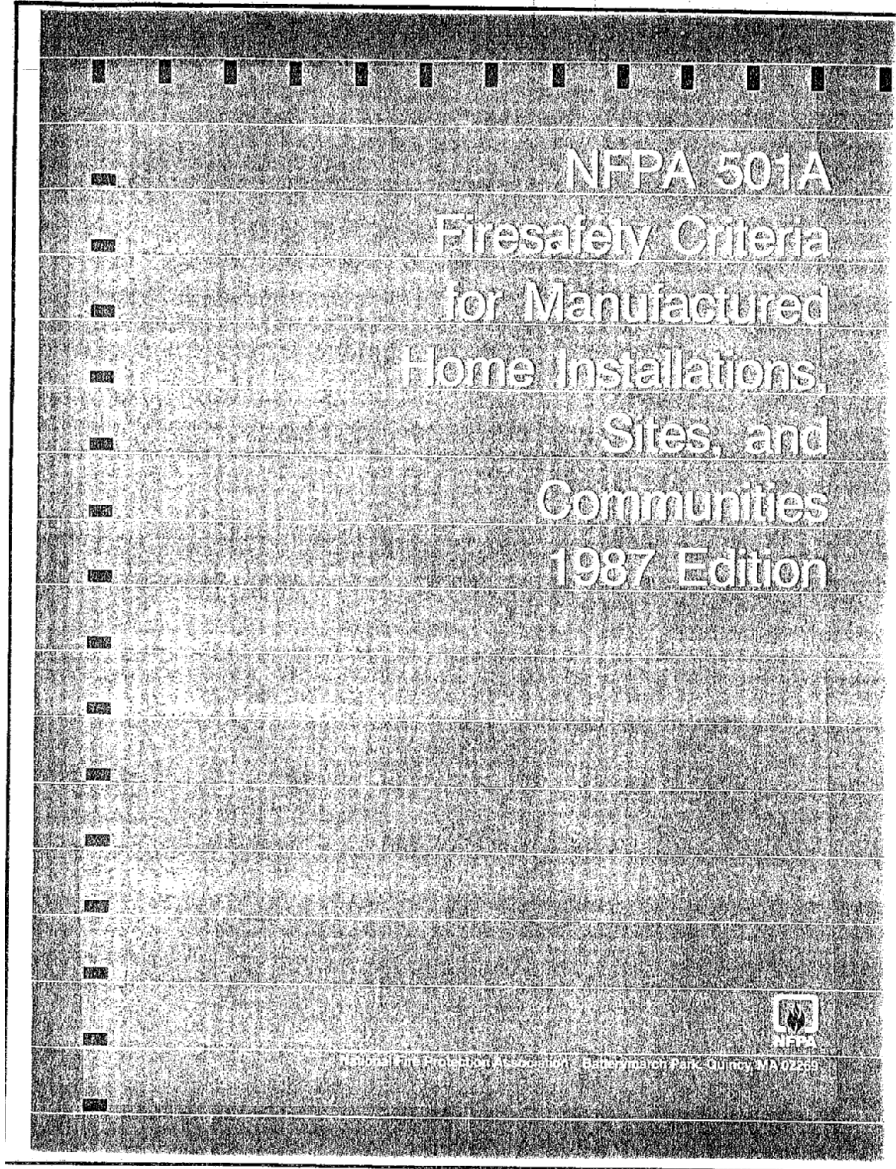


**Gas Standard**

Distribution Operations

|                               |  |   |
|-------------------------------|--|---|
| Effective Date:<br>09/10/1990 | <b>Gas Facilities on Customer Premises</b> | Standard Number:<br><b>GS 6000.010(CG)</b><br>P&P 700-3 |
| Supersedes:<br>N/A            |  | Page 7 of 7   |

**EXHIBIT D**





Distribution Operations

|                               |                           |   |
|-------------------------------|---------------------------|---|
| Effective Date:<br>07/01/2008 | <b>Customer Emergency</b> | Standard Number:<br><b>GS 6100.010(CG)</b><br>P&P 721-1 |
| Supersedes:<br>N/A            |                           | Page 1 of 1   |

Companies Affected:

|                                 |   |   |
|---------------------------------|---|---|
| <input type="checkbox"/> NIPSCO | <input checked="" type="checkbox"/> CGV | <input checked="" type="checkbox"/> CMD |
|                                 | <input checked="" type="checkbox"/> CKY | <input checked="" type="checkbox"/> COH |
|                                 | <input type="checkbox"/> CMA            | <input checked="" type="checkbox"/> CPA |

**REFERENCE**    None

**1. GENERAL REQUIREMENTS**

Service requests of the following nature are considered by the Company to be a "customer emergency" and are to be worked immediately, regardless of the time of day or day of the week. There will be no charge for this service.

- a. Odor of gas
- b. Odor of fumes
- c. Carbon Monoxide
- d. To restore gas service after a leak has been repaired if seasonal temperatures could cause damage.
- e. To correct inadequate gas service resulting from the Company's operations or equipment.

**NOTE:** Every effort is to be made with the customer to establish gas service during the normal work schedule. However, when a customer is moving into the community from out of town and has not had an opportunity to contact our office to request a turn-on, and if being without gas service creates a potential health hazard, the order should be considered an emergency. For Pennsylvania and Maryland, establish gas service in reference to medical certificates following Pennsylvania Act 201 of 2004 or Maryland COMAR procedures.





**Gas Standard**

Distribution Operations

|                               |  |   |
|-------------------------------|--|---|
| Effective Date:<br>06/17/1996 | <b>Charges for Customer Authorized Service</b> | Standard Number:<br><b>GS 6200.010(CG)</b><br>P&P 722-1 |
| Supersedes:<br>N/A            |  | Page 1 of 7   |

Companies Affected:

|                                     |   |   |
|-------------------------------------|---|---|
| <input type="checkbox"/> NIPSCO     | <input type="checkbox"/> CGV            | <input type="checkbox"/> CMD            |
| <input type="checkbox"/> NIFL       | <input checked="" type="checkbox"/> CKY | <input checked="" type="checkbox"/> COH |
| <input type="checkbox"/> Kokomo Gas | <input type="checkbox"/> CMA            | <input type="checkbox"/> CPA            |

**REFERENCE** None

**1. GENERAL REQUIREMENTS**

The individual state rates will be applied to all work done at the request of the customer in accordance with Company policy. Those cases where a separate Service Agreement has been signed by the Company are accepted from this charge policy.

When the primary reason for the service call is appliance repair, the time for the labor charge shall start when the service person reaches the customer premises and end when the service person leaves the premises after the work is completed.

When labor charges are applied and the primary reason for the service call is other than appliance repair, the time for the labor charge shall start at the time the actual appliance repair is started and end when the appliance repair is completed.

The service performed within this policy will carry a 30 day labor warranty, but on parts and materials the Company will honor only the manufacturer's warranty

Where special arrangements are made to do customer premises work and, upon arriving at the customer's premise, we cannot gain access to perform the previously scheduled service work, a "Call Back" charge may be made. The "Call Back" charge will be equal to the first hour minimum charge in effect for that time of day.

Replaced parts are to be left on the customer's premises unless the customer requests otherwise.

**2. LABOR RATES**

The rates to be charged for customer authorized service shall be made in accordance with one of the two applicable rate schedules as follows:

Schedule A - this rate schedule shall be applied when the customer has requested the

*This document is considered CONTROLLED only when viewed electronically on the Company's intranet. Printed or other electronic copies may not be current, and the intranet version should be used to verify.*



Distribution Operations

|                               |  |   |
|-------------------------------|--|---|
| Effective Date:<br>06/17/1996 | <b>Charges for Customer Authorized Service</b> | Standard Number:<br><b>GS 6200.010(CG)</b><br>P&P 722-1 |
| Supersedes:<br>N/A            |  | Page 2 of 7   |

Company to do appliance service work for which there is a charge and the Company has issued a service order for this purpose.

Schedule B - this rate shall apply when appliance service was performed during a service call when the reason for the service call was other than appliance service.

The applicable time intervals for the customer authorized service charge shall be made in accordance with Exhibit A. The rates for these time intervals are set or adjusted as determined by the Presidents of each Operating Distribution Company.

**3. MATERIAL CHARGES**

All parts initially charged to Account 879 will be billed to the customer at the invoice cost plus shipping charges and 10% markup.

All materials in stock (charged to Account 154) shall be marked up at the prevailing stores expense overhead rate when sold to the customer.

**4. CUSTOMER'S EQUIPMENT PARTS REPAIRED**

Parts removed from customer's equipment and sent for repair will be charged at the repair cost with no material markup. Labor charge will be made for time involved.

**5. DIS ORDER**

The billable DIS Order should be forwarded to the appropriate Customer Service Center for processing.

A computer-generated DIS Order will be generated for customer requested service. The computer-generated DIS Order shall be completed when the order is worked. The reverse side of Form C-2652, "DIS Order," shall be completed showing the detail of labor and material and attached to the computer-generated DIS Order, when applicable. See Exhibit B.



Distribution Operations

|                               |  |   |
|-------------------------------|--|---|
| Effective Date:<br>06/17/1996 | <b>Charges for Customer Authorized Service</b> | Standard Number:<br><b>GS 6200.010(CG)</b><br>P&P 722-1 |
| Supersedes:<br>N/A            |  | Page 3 of 7   |

**EXHIBIT A  
(1 of 2)**

**CHARGES FOR CUSTOMER AUTHORIZED SERVICE**

**SCHEDULE A**

Schedule A is applicable for work completed when appliance service is the primary reason for the order.

I. For Work Done During Regular Working Hours:

| TIME INTERVAL   | PERSONNEL RATES                                   |
|---|---|
| Up to the first hour charge for:                                  | One service person at ***.                        |
|   | Each additional service person at ***.            |
| After the first hour charge to the nearest ¼ hour thereafter for: | One service person at *** per ¼ hour.             |
|   | Each additional service person at *** per ¼ hour. |

II. For Work Done Outside Regular Working Hours (Including Holidays):

| TIME INTERVAL   | PERSONNEL RATES                                   |
|---|---|
| Up to the first hour charge for:                                  | One service person at ***.                        |
|   | Each additional service person at ***.            |
| After the first hour charge to the nearest ¼ hour thereafter for: | One service person at *** per ¼ hour.             |
|   | Each additional service person at *** per ¼ hour. |

\*\*\*Personnel Rates are set or adjusted as determined by the Presidents of each Operating Company.



Distribution Operations

|                               |  |   |
|-------------------------------|--|---|
| Effective Date:<br>06/17/1996 | <b>Charges for Customer Authorized Service</b> | Standard Number:<br><b>GS 6200.010(CG)</b><br>P&P 722-1 |
| Supersedes:<br>N/A            |  | Page 4 of 7   |

**EXHIBIT A  
(2 of 2)**

**SCHEDULE B**

Schedule B is applicable for work completed when appliance service **is not** the primary reason for the call.

I. For Work Done During Regular Hours:

| TIME INTERVAL | PERSONNEL RATES                                   |
|---------------|---|
| Each ¼ Hour   | One service person at *** per ¼ hour.             |
|               | Each additional service person at *** per ¼ hour. |

II. For Work Done Outside Regular Working Hours (Including Holidays):

| TIME INTERVAL | PERSONNEL RATES                                   |
|---------------|---|
| Each ¼ Hour   | One service person at *** per ¼ hour.             |
|               | Each additional service person at *** per ¼ hour. |

\*\*\*Personnel Rates are set or adjusted as determined by the Presidents of each Operating Distribution Company.



**Gas Standard**

Distribution Operations

|                               |  |   |
|-------------------------------|--|---|
| Effective Date:<br>06/17/1996 | <b>Charges for Customer Authorized Service</b> | Standard Number:<br><b>GS 6200.010(CG)</b><br>P&P 722-1 |
| Supersedes:<br>N/A            |  | Page 5 of 7   |

**EXHIBIT B  
(1 of 3)**

```

COH - DIS ORDER PAGE 1 OF 2 TAKEN 02/27/1996,1433 TO BE WORKED 02/27/1996

LABAMBA FOR: SERVICE ORDER TYPE: AP
1980 N HIGH ST B PRINT SEQ # 00039 UN/BK 04/86 SADC M5
COLUMBUS OH 432011165 ORDER SEQ # 25 DSK 4 PSID 300133904
FRANKLIN COUNTY OVERFLOW
PHONES: HOME 614-555-5004 WORK 614-555-5004 OTHER
ACC: ACTIVE COMMERCIAL HEAT ACCT CLASS: 879- - - -03311- 1325 0250010
COLUMBUS
COLUMBUS CITY (S.D.)
M/L: A 34100056 LP .0 .0 0805 15FFB N3W1
SL : * 00006 0305 00/00/46
EFV: 37LRB 9FFB METER VALVE
CSL: 000 00/00/00
MSA: ROCKWELL ROTOSEAL R11 806 COH 01-1991 1997 HAS00037 ROT 6
----- 0.2 LADIES RESTROOM ON NO 0 00
IN CEILING ABOVE REMOTE DOOR - FRONT
PROPERTY RENTED-PROP OWNER INFO ON FILE PRESS COMP CD IS 2 TEMP COMP CD IS 0
CAUTION MTR RDG: ON: CVO: MVO: REMV CD:
ORDER INSTR:
REPAIR RANGE

BET STRS: &
CORNER STR: SUBDIV:
APPL CONN: A-C C HEAT DRYER GRILL RANGE W HEAT OTHER
MKT APPL:

PREMISE AUDIT DATE: 00/00/0000
WORK COMPLETED: YES NO FUTHER ACTION REQUIRED: YES
CUSTOMER TO BE CHARGED: YES NO LABOR & MATERIAL DETAIL ATTACHED: YES
REMARKS:

I HAVE FOLLOWED ALL APPLICABLE COMPANY PRACTICES,
POLICIES AND PROCEDURES IN COMPLETING THIS ORDER. SIGNED:
AR TM: LV TM: DATE: 04/06 READING 0037587MOS CALC: 0
    
```



Gas Standard

Distribution Operations

|                               |  |   |
|-------------------------------|--|---|
| Effective Date:<br>06/17/1996 | <b>Charges for Customer Authorized Service</b> | Standard Number:<br><b>GS 6200.010(CG)</b><br>P&P 722-1 |
| Supersedes:<br>N/A            |  | Page 6 of 7   |

**EXHIBIT B**  
**(2 of 3)**

|  |   |  |  |
|--|---|--|--|
| <b>DIS ORDER</b>   |   | No. 358251   |  |
| COMPANY  | DATE TAKEN  | TIME TAKEN   | DATE TO BE WORKED <input type="checkbox"/> AM <input type="checkbox"/> PM  |
| CUSTOMER NAME  |   | <input type="checkbox"/> PLANT <input type="checkbox"/> OTHER  | ORDER TYPE   |
| SERVICE ADDRESS  |   | PRINT SEQUENCE   | SADC   |
| CITY   | STATE   | ZIP CODE   | ORDER SEQUENCE PSID  |
| COUNTY   | EMPLOYEE ASSIGNED TO:   |  |  |
| PHONE NUMBERS  |   |  |  |
| <b>HOME</b>  |   | <b>WORK</b>  |  |
| ACCT. STATUS   | REVENUE CLASS   | ACCT. CLASS  | LOC. NO. TAXING DISTRICT   |
| ACCOUNTABILITY CODE  | MAIN NUMBER   | OPERATING PRESS. MAOP  | MOP MAIN CODE MAP NUMBER   |
| MT. CODE   | MASTER TAP LOCATION   | LENGTH OF SERVICE  | SERVICE TYPE SPECIAL CODE DATE INSTALL   |
| CURB BOX LOCATION OR PSID  |   | CUST. VALVE LOCATION OR PSID   |  |
| METER NAME/MODEL   | KIND/SIZE   | METER OWNERSHIP  | TEST/SET DATE YEAR TEST DUE SERIAL NO. TYPE DIALS  |
| CAPACITY   | COMP. PRESS. COMP. TEMP. DELIVERY PRESS. TEST LOC.                              | LOCATION CODE  | SHUT OFF CODE THEFT DEVICE REG. CODE B/REG.  |
| METER INSTRUCTIONS #1  |   | METER INSTRUCTIONS #2  |  |
| METER INSTRUCTIONS #3  |   | METER READING  | OUT: ON: OFF:  |
| ORDER INSTRUCTIONS   |   |  |  |
| APPLIANCE CONNECTED:<br><input type="checkbox"/> A-C <input type="checkbox"/> C-HEAT <input type="checkbox"/> DRYER <input type="checkbox"/> GRILL <input type="checkbox"/> RANGE <input type="checkbox"/> W-HEATER <input type="checkbox"/> OTHER |   |  | FURTHER ACTION REQUIRED <input type="checkbox"/> YES <input type="checkbox"/> NO   |
| NEW METER INFORMATION  | KIND/SIZE SERIAL NO. DIALS READING  | IN   | RELATED FORMS ATTACHED <input type="checkbox"/> YES <input type="checkbox"/> NO  |
| CUSTOMER ID #1   | CUSTOMER ID #2  |  |  |
| CUSTOMER SIGNATURE   | CUSTOMER TO BE CHARGED <input type="checkbox"/> YES <input type="checkbox"/> NO |  | LABOR AND MATERIALS DETAIL ON REVERSE  |
| DPI NEEDED <input type="checkbox"/> YES <input type="checkbox"/> NO  | DPI NUMBER & CLASS  | WORK COMPLETE <input type="checkbox"/> YES <input type="checkbox"/> NO   | HOUSE LINE: <input type="checkbox"/> APPROVED <input type="checkbox"/> DISAPPROVED<br>SERV. LINE: <input type="checkbox"/> APPROVED <input type="checkbox"/> DISAPPROVED |
| CONSUMPTION HISTORY  |   | GAS OFF AT <input type="checkbox"/> METER <input type="checkbox"/> CURB <input type="checkbox"/> YES <input type="checkbox"/> NO |  |
| CURRENT YEAR   |   | PREVIOUS YEAR  |  |
| PER CONS   | CODE DAYS   | PER CONS   | CODE DAYS  |
| 1st  |   | 12th   |  |
| 2nd  |   | 13th   |  |
| 3rd  |   | 14th   |  |
| 4th  |   | READING  | <input type="checkbox"/> REMOTE <input type="checkbox"/> METER   |
| 5th  |   |  |  |
| REMARKS  |   |  |  |
| PROPERTY OWNER INFORMATION   |   |  |  |
| P.O. NAME  |   |  |  |
| P.O. ADDRESS   |   |  |  |
| P.O. CITY, STATE, ZIP CODE   |   |  |  |
| P.O. TELEPHONE   |   |  |  |
| I HAVE FOLLOWED ALL APPLICABLE COMPANY PRACTICES, POLICIES AND PROCEDURES IN COMPLETING THIS ORDER. SIGNED:  |   |  |  |
| ARRIVAL TIME   | LEAVE TIME  | TIME MADE SAFE   | DATE   |
| FORM C 2852 CSD  |   |  |  |



Gas Standard

Distribution Operations

|                               |  |   |
|-------------------------------|--|---|
| Effective Date:<br>06/17/1996 | <b>Charges for Customer Authorized Service</b> | Standard Number:<br><b>GS 6200.010(CG)</b><br>P&P 722-1 |
| Supersedes:<br>N/A            |  | Page 7 of 7   |

**EXHIBIT B**  
**(3 of 3)**

CUSTOMER PREMISE WORK

| DETAIL OF PARTS AND MATERIAL USED |                  |                 |              |            |       | DETAIL OF LABOR    |       |        |
|-----------------------------------|------------------|-----------------|--------------|------------|-------|--------------------|-------|--------|
| QUAN- TITY                        | SIZE OR PART NO. | DESCRIPTION     | DATE ORDERED | DATE REC'D | COST  | EMPLOYEE           | HOURS | AMOUNT |
| 1                                 | 14357-307        | Hi-Temp. Switch |              |            | 10 00 | I. B. Service      | 1     | 55 00  |
|                                   |                  | Mark-up 10%     |              |            | 1 00  |                    |       |        |
|                                   |                  |                 |              |            |       | BILLING CHARGES    |       |        |
|                                   |                  |                 |              |            |       | MATERIAL AND LABOR |       | 55 00  |
|                                   |                  |                 |              |            |       | PARTS              |       | 11 00  |
|                                   |                  |                 |              |            |       | OTHER COSTS        |       |        |
|                                   |                  |                 |              |            |       | SALES TAX          |       | 60     |
| TOTAL                             |                  |                 |              |            | 11 00 | TOTAL              |       | 66 60  |

|   |                        |    |                                |    |                    |
|---|------------------------|----|--------------------------------|----|--------------------|
| CUSTOMER PREMISES WORK<br>I hereby authorize the GAS COMPANY to perform the necessary services required and to bill me for any costs involved.<br>Signed <u>D. B. Pleased</u><br>CUSTOMER | TIME ARRIVED           | AM | TIME COMPLETED                 | AM | DATE COMPLETED     |
|   | 10:05                  | PM | 10:55                          | PM | 4   10   96        |
|   | SERVICEMAN'S SIGNATURE |    |                                |    | ACCOUNT NUMBER     |
|   | <u>IB Service</u>      |    |                                |    | 879-3412           |
| 2ND DAY-ARRIVED   |                        | AM | 2ND DAY-COMPLETED              | AM | 2ND DAY DATE COMP. |
|   |                        | PM |                                | PM |                    |
| PURCHASE ORDER NO.  |                        |    | SERVICEMAN'S SIGNATURE-2ND DAY |    | ACCOUNT NUMBER     |

REPORT:

Unit was off on generator high temperature switch.

Replaced switch and unit is working OK now.

Unit Model AY 36-120

Serial No. 0023167



Distribution Operations

|                               |   |   |
|-------------------------------|---|---|
| Effective Date:<br>09/01/1998 | <b>Service on Gas Appliances and/or House Lines</b> | Standard Number:<br><b>GS 6200.030(KY)</b><br>P&P 722-3(32) |
| Supersedes:<br>N/A            |   | Page 1 of 2   |

Companies Affected:

|                                     |   |                              |
|-------------------------------------|---|------------------------------|
| <input type="checkbox"/> NIPSCO     | <input type="checkbox"/> CGV            | <input type="checkbox"/> CMD |
| <input type="checkbox"/> NIFL       | <input checked="" type="checkbox"/> CKY | <input type="checkbox"/> COH |
| <input type="checkbox"/> Kokomo Gas | <input type="checkbox"/> CMA            | <input type="checkbox"/> CPA |

**REFERENCE**    None

**1. APPLIANCE SERVICE AND/OR HOUSE LINE INSPECTION AND REPAIR – NO CHARGE**

The following safety checks and repairs will be made on the customer’s appliances and house lines at no charge when performed in conjunction with other customer premise work such as turning gas on, changing meters.

- a. Light Pilot Light
- b. Primary air shutter adjustments
- c. Combustion/Ventilation air checks
- d. Inspection of appliance vent
- e. Appliance Safety Control (where applicable)

**2. APPLIANCE SERVICE AND/OR HOUSE LINE INSPECTION AND REPAIR FOR WHICH CUSTOMERS MAY BE CHARGED**

At the customer’s request, when not in conjunction with a meter/service order that requires this work, the following inspections and repairs will be performed on the customer’s premise at the present tariff rate:

- a. Safety Inspection on appliances as outlined in [GS 6500.150\(CG\)](#).
- b. Light Appliances and/or minor appliance repairs (other than heating equipment). Every effort should be made to refer these calls to qualified contractor.
- c. Safety inspection follow-up on a Red Tagged appliance.
- d. House line test on other than a Priority call
- e. Contractor and/or customer request to assist in turning gas off at the meter

*This document is considered CONTROLLED only when viewed electronically on the Company's intranet. Printed or other electronic copies may not be current, and the intranet version should be used to verify.*





**Gas Standard**

Distribution Operations

|                               |   |   |
|-------------------------------|---|---|
| Effective Date:<br>09/01/1998 | <b>Service on Gas Appliances and/or<br/>House Lines</b> | Standard Number:<br><b>GS 6200.030(KY)</b><br>P&P 722-3(32) |
| Supersedes:<br>N/A            |   | Page 2 of 2   |

- f. Contractor and/or customer request to assist in turning gas on at the meter

The customer or customer's representative must be present during these inspections or provide proper authorization for billing purposes.



**Gas Standard**

Distribution Operations

|                               |                      |   |
|-------------------------------|----------------------|---|
| Effective Date:<br>08/15/1977 | <b>Bypass Valves</b> | Standard Number:<br><b>GS 6400.020(CG)</b><br>P&P 724-2 |
| Supersedes:<br>N/A            |                      | Page 1 of 2   |

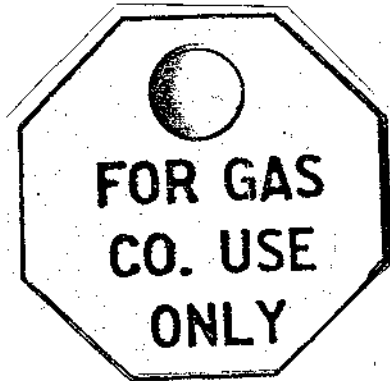
Companies Affected:

|                                     |   |   |
|-------------------------------------|---|---|
| <input type="checkbox"/> NIPSCO     | <input checked="" type="checkbox"/> CGV | <input checked="" type="checkbox"/> CMD |
| <input type="checkbox"/> NIFL       | <input checked="" type="checkbox"/> CKY | <input checked="" type="checkbox"/> COH |
| <input type="checkbox"/> Kokomo Gas | <input type="checkbox"/> CMA            | <input checked="" type="checkbox"/> CPA |

**REFERENCE**    None

**1. GENERAL REQUIREMENTS**

The inlet valve in regulator or meter bypass lines on customer retail measurement stations shall have a seal or locking device installed to discourage use by unauthorized people. A tag as shown below shall be attached to the bypass valve stating "For Gas Company Use Only." These tags and fasteners are available from the Stationery Warehouse by using a Stationery Supply Requisition, Form No. C-233 (Exhibit A).



Actual Size - Color White

*This document is considered CONTROLLED only when viewed electronically on the Company's intranet. Printed or other electronic copies may not be current, and the intranet version should be used to verify.*



Gas Standard

Distribution Operations

|                                       |                        |  |
|---------------------------------------|------------------------|--|
| <p>Effective Date:<br/>08/15/1977</p> | <h1>Bypass Valves</h1> | <p>Standard Number:<br/><b>GS 6400.020(CG)</b><br/>P&amp;P 724-2</p> |
| <p>Supersedes:<br/>N/A</p>            |                        | <p>Page 2 of 2</p>   |

EXHIBIT A

(GAS)

### STATIONERY SUPPLY REQUISITION

NOTE: Order requisition forms by number/parts. All other case forms and tables show number of pieces desired. SEND THE ORIGINAL (PINK) AND DUPLICATE (WHITE) COPIES OF ORDER TO CENTRAL STOCK ROOM.

Date of Requisition: 6/7/77

Department: Service

Approved by: Jim Russo

Title: AREA MANAGER

Ship To: COLUMBIA GAS OF OHIO, INC  
ATTN: JIM GASCO  
US RT 500 E  
ATHENS, OHIO

| FORMING | QUANTITY | DESCRIPTION   |
|---------|----------|---|
|         |          | "FOR GAS CO. USE ONLY"<br>PLASTIC TAG WITH FASTENER |

FILED BY: \_\_\_\_\_ DATE: \_\_\_\_\_ ORIGINAL

Misc. Items: \_\_\_\_\_  
Temporarily Out of Stock: \_\_\_\_\_  
Item: \_\_\_\_\_  
With Order: \_\_\_\_\_  
No. Requisition Needed: \_\_\_\_\_



Distribution Operations

|                               |   |   |
|-------------------------------|---|---|
| Effective Date:<br>10/31/1991 | <b>Installation and Operations<br/>Requirements for Large Volume<br/>CAB and GMB Meter Set<br/>Assemblies</b> | Standard Number:<br><b>GS 6400.030(CG)</b><br>P&P 724-3 |
| Supersedes:<br>N/A            |   | Page 1 of 30  |

Companies Affected:

|                                     |   |   |
|-------------------------------------|---|---|
| <input type="checkbox"/> NIPSCO     | <input checked="" type="checkbox"/> CGV | <input type="checkbox"/> CMD            |
| <input type="checkbox"/> NIFL       | <input checked="" type="checkbox"/> CKY | <input checked="" type="checkbox"/> COH |
| <input type="checkbox"/> Kokomo Gas | <input type="checkbox"/> CMA            | <input type="checkbox"/> CPA            |

**REFERENCE** Columbia Gas System - Gas Facilities Committee - documents No. 1 - Standard Paint Color Manual and No. 6 – “Gas Measurement Standards and Calculations.”

**1. GENERAL**

CDC will furnish and connect a meter for each customer, and this meter will remain the property of Company.

A Company representative will confer with the customer in planning a new meter set assembly or the modification of an existing one. The Company shall reserve the right to determine the type and size of the measurement equipment to be installed.

A meter, as received from the manufacturer or meter shop, shall be transported (ends properly capped, holes plugged, displacement meter shipped upright, etc.), and handled in a manner that will not appreciably affect its certified accuracy.

When a piping system that contains a meter set assembly is to be hydro-statically tested, the meter shall be removed and a spool or blind flange shall temporarily be installed.

**2. LOCATION OF A METER SET ASSEMBLY**

The meter set assembly shall be located where it will be accessible for reading, inspection, maintenance and/or replacement and convenient to both Company and customer, and shall not be subjected to adverse operating conditions, e.g., high or low ambient temperatures that affect meter operation, vibration, etc. When locating the meter set assembly, the following shall be considered: ventilation, protection when in a traffic area, safe access and vandalism. The meter set assembly shall not be installed closer than three feet to known sources of ignition, e.g., electrical panel or meter, furnace, incinerator, etc., or any source of heat which might damage the meter.

The Company reserves the right to determine the final location of the meter set assembly.

*This document is considered CONTROLLED only when viewed electronically on the Company's intranet. Printed or other electronic copies may not be current, and the intranet version should be used to verify.*



Distribution Operations

|                               |   |   |
|-------------------------------|---|---|
| Effective Date:<br>10/31/1991 | <b>Installation and Operations<br/>Requirements for Large Volume<br/>CAB and GMB Meter Set<br/>Assemblies</b> | Standard Number:<br><b>GS 6400.030(CG)</b><br>P&P 724-3 |
| Supersedes:<br>N/A            |   | Page 2 of 30  |

**2.1 Customer Accounting Billing (CAB) Customers - Low Pressure Metering**

For customer owned customer service line installations the meter set assembly shall be located in accordance with Form C 2235, "Standards for Customer Owned Service Lines," Exhibit A. For Company owned customer service lines the meter set assembly shall be located in accordance with [GS 3020.010](#) "Service Line Installation."

**2.2 Customer Accounting Billing (CAB) Customers - Fixed Pressure Factor Metering (FPFM)**

As applicable, these meter set assemblies shall be located as specified for a CAB low pressure account or a Gas Measurement Billing (GMB) account.

**2.3 Gas Measurement Billing (GMB) Customers**

When possible, the meter set assembly shall be located as near as practical to the customer's property line at the point where the gas service line enters the customer's property.

**3. PROTECTION OF A METER SET ASSEMBLY**

The Company representative shall determine if a meter set assembly is in an area where it may be exposed to damage and what type of protection is required.

The Marketing Representative shall be consulted for assistance when the type of protection selected will require negotiating with the customer. Those cases where a decision on the type of protection needed will require special engineering or the budgeting of monies should be referred to the Engineering - Measurement and Regulation Manager.

Types of protection are: building, fencing, and pipe posts or equivalent. It is recommended that installations on public grounds be housed or fenced.

**3.1 Building**

Where necessary, the customer shall be required to provide and maintain a building, per Company specifications, to house the meter set assembly installed on the property. A building shall be selected or designed that will enable access to and allow sufficient clearance around the meter set assembly for scheduled maintenance and chart changing.

A building housing a meter set assembly shall be locked. A customer owned building may



Distribution Operations

|                               |   |   |
|-------------------------------|---|---|
| Effective Date:<br>10/31/1991 | <b>Installation and Operations<br/>Requirements for Large Volume<br/>CAB and GMB Meter Set<br/>Assemblies</b> | Standard Number:<br><b>GS 6400.030(CG)</b><br>P&P 724-3 |
| Supersedes:<br>N/A            |   | Page 3 of 30  |

be locked using a dual locking system as shown in Exhibit B.

### 3.2 Fencing

In those situations where it is determined that fencing is adequate protection, the customer shall be required to install and maintain a suit-able fence, such as a chain link type. The fence will be installed at a sufficient distance around the meter set assembly to allow easy access to and provide working space around the metering and regulating equipment and shall be locked as shown in Exhibit B.

### 3.3 Pipe Posts or Equivalent Barriers

Pipe posts or equivalent barriers shall be installed and maintained by the customer to protect the meter set assembly when there is a high probability from vehicular damage. This protection may be necessary even though a building or fencing is required. Barriers shall be located to allow easy access to the meter.

## 4. INSTALLATION

### 4.1 Standard Meter Set Assemblies

Refer to CDC standard drawings of CAB and GMB meter set assemblies. These standard drawings can be obtained from the Engineering - Facilities Planning and Design Section.

### 4.2 Prevention of Corrosion

The meter set assembly shall be installed in such a manner that the bottom of the meter will be a minimum of six inches above finished grade. An insulated fitting shall be installed to provide electrical separation between the house and service line.

### 4.3 Bypass Piping

A valved bypass shall be installed around a meter setting when any anticipated interruption of gas to a customer may cause an undue hard-ship. Anticipated interruptions are periodically scheduled maintenance, testing, etc. Permanent bypasses may be installed or provisions made for the use of temporary bypasses. Bypasses may contain a regulator if the service pressure to the customer must be controlled.

The bypass valve shall be a positive shut-off type and the bypass shall be locked or



Distribution Operations

|                               |   |   |
|-------------------------------|---|---|
| Effective Date:<br>10/31/1991 | <b>Installation and Operations<br/>Requirements for Large Volume<br/>CAB and GMB Meter Set<br/>Assemblies</b> | Standard Number:<br><b>GS 6400.030(CG)</b><br>P&P 724-3 |
| Supersedes:<br>N/A            |   | Page 4 of 30  |

sealed.

#### **4.4 Shut-Off Valve**

For GMB customers a positive shut-off type valve shall be installed on all inlet risers and on the outlet risers of meters that are periodically scheduled for testing. If lubricated type valves are used, care should be taken to prevent over lubricating the meter inlet riser valve, as excessive valve lubricant entering the meter may cause meter damage or stoppage.

#### **4.5 Spacing**

The meters in a multiple meter set assembly shall be spaced so that installation, maintenance, testing and removal of a meter can be accomplished without disturbing the adjacent meter(s). If a meter(s) is housed in a building, the door opening shall be adequately sized to permit meter changes.

#### **4.6 Meter Support**

When a meter is supported by the piping, the piping shall be aligned and supported (metal pipe stand or masonry material) to prevent undue strain on the meter, regulator, piping or fittings.

When a meter is installed to rest on a permanent base such as a concrete pad or metal stand, the base shall be able to carry the weight without settlement. Consideration should be given to the possibility of frost heave when installing a permanent base.

#### **4.7 Identification**

##### **4.7.1 Customer Accounting Billing (CAB) Customers**

On multiple meter installations, each meter valve shall be plainly and properly identified by the installing agent with a weather proof tag, designating the part of the building it supplies.

##### **4.7.2 Gas Measurement Billing (GMB) Customers**

Each meter or meter run in a meter set assembly shall be identified with its assigned ID number on a weather proof tag (metal tag, plastic tag, history card, etc.) attached in a conspicuous location. Refer to [GS 6400.200\(CG\)](#)





Distribution Operations

|                               |   |   |
|-------------------------------|---|---|
| Effective Date:<br>10/31/1991 | <b>Installation and Operations<br/>Requirements for Large Volume<br/>CAB and GMB Meter Set<br/>Assemblies</b> | Standard Number:<br><b>GS 6400.030(CG)</b><br>P&P 724-3 |
| Supersedes:<br>N/A            |   | Page 5 of 30  |

“Measuring Station Numbering System - Gas Measurement Billing (GMB).”

To facilitate operation of meter set assemblies where the piping, instrument lines or valving are difficult to trace, a drawing of the facility shall be kept at the station.

**4.8 Instrumentation**

Temperature wells, pressure taps and other auxiliary connections shall be installed in accordance with CDC standard drawings.

When an instrument is installed, the input drive of the instrument (cubic feet per revolution) shall be checked to assure that it matches the output drive of the meter (cubic feet per revolution).

The static pressure range of an instrument installed on a meter shall be selected so that the operating pressure remains between 10% and 90% of the pressure element range.

Each recording gauge installed on a permanent un-housed meter setting shall be protected from the elements with some type of enclosure or covering. The valve handle on the pressure supply line to the instrument shall be removed or secured to prevent tampering if the meter setting is unprotected by a building, fence or other enclosure.

A shut-off valve shall be installed in each pressure sensing line as near as practical to the point of take-off. Instrument piping which extends to remote locations (adjacent room or building) shall be coded so that it can be quickly traced and the shut-off valve identified and closed in an emergency.

**4.9 Blow-down Valve**

It is recommended that a blow-down valve be installed on the meter's downstream piping when a meter has a periodic test or maintenance schedule to enable the depressurization of the meter and piping. The blow-down valve shall be sized to prevent over-speeding of the meter. Recommended sizes are the following:





Distribution Operations

|                               |  |   |
|-------------------------------|--|---|
| Effective Date:<br>10/31/1991 | <b>Installation and Operations<br/>                 Requirements for Large Volume<br/>                 CAB and GMB Meter Set<br/>                 Assemblies</b> | Standard Number:<br><b>GS 6400.030(CG)</b><br>P&P 724-3 |
| Supersedes:<br>N/A            |  | Page 6 of 30  |

| Meter Inlet Piping Size | Valve Size |
|-------------------------|------------|
| 2"                      | 1/4"       |
| 3"                      | 1/2"       |
| 4"                      | 1/2"       |
| 6"                      | 1"         |
| 8"                      | 1"         |
| 12"                     | 1"         |

When exhausting of the blow-down gas would create a hazardous condition, it shall be burned off in accordance with the guidance established in CDC's "Measurement Informational Guide."

**4.10 Test Connections**

A diaphragm meter setting shall be provided with adequately sized test connections to enable testing the meter to its maximum capacity when it is periodically scheduled for on-site recertification of accuracy. Test connections shall be located on the inlet and outlet meter piping and as close to the meter as practical. When the meter inlet and outlet piping has been reduced below the size of the meter connections, the test connections shall be located prior to reduction on the larger size piping.

Rotary and turbine meters do not require test connections.

**4.11 Meter Working Pressure**

A meter shall not be operated at a pressure that is higher than the manufacturer's stamped working pressure as identified on the meter badge.

**4.12 Drips, Separators and Scrubbers**

When the amount of pipeline debris is such that it affects the accuracy of a meter or causes it to malfunction, a drip, separator, scrubber or comparable device shall be installed upstream to the meter. Additional meter protection may be achieved through the use of a strainer or filter installed in the meter upstream piping.

**5. OPERATION**

To prevent damage to a meter, prior to installing it, the inlet piping to the meter setting shall



Distribution Operations

|                               |   |   |
|-------------------------------|---|---|
| Effective Date:<br>10/31/1991 | <b>Installation and Operations<br/>Requirements for Large Volume<br/>CAB and GMB Meter Set<br/>Assemblies</b> | Standard Number:<br><b>GS 6400.030(CG)</b><br>P&P 724-3 |
| Supersedes:<br>N/A            |   | Page 7 of 30  |

be blown to the atmosphere to remove any collection of debris.

**5.1 Pressurizing and Depressurizing Meter Setting**

To pressurize or depressurize the meter, the inlet or out-let valve shall be opened or closed slowly to prevent damage to the rotating parts of the meter caused by excessive acceleration. (It is recommended that the rate of pressurizing and depressurizing the meter should not exceed 5 psi per second.)

**5.2 Flow Imbalance**

Small flow imbalances across a multiple meter set assembly may be corrected through the use of restriction plates installed downstream of the meter or by throttling the downstream valve. Throttling should not affect the sensing of the correct meter temperature or reflect disturbances to the meter.

**5.3 Bypassing of Combination Meter Set Assemblies**

The bypassing of a combination meter set assembly, which consists of a meter, control regulator and monitor regulator installed in series, shall be performed with caution to avoid over speeding the meter, over or under pressurizing the downstream pipe-line, or interrupting the gas delivery to the customer. A downstream pressure gauge shall be monitored during the bypassing operation. To avoid false readings, this pressure gauge shall not be installed on the meter set assembly piping, especially not on the setting bypass piping.

In fixed pressure factor measurement (FPFM) accounts the bypassed gas shall be regulated as near as possible to the specified delivery pressure for the account.

When bypassing a meter set assembly, it shall be done by a trained employee. When only a valve is installed in the bypass, a second employee shall be available to operate this bypass valve to maintain the customer's delivery pressure.

**5.4 Billing Adjustments**

If during the bypassing operation, the bypassed gas or index build-up would result in a billing adjustment in excess of one Mscf (one thousand standard cubic feet) an estimate of the gas bypassed shall be made.



Distribution Operations

|                               |   |   |
|-------------------------------|---|---|
| Effective Date:<br>10/31/1991 | <b>Installation and Operations<br/>Requirements for Large Volume<br/>CAB and GMB Meter Set<br/>Assemblies</b> | Standard Number:<br><b>GS 6400.030(CG)</b><br>P&P 724-3 |
| Supersedes:<br>N/A            |   | Page 8 of 30  |

**5.4.1 Customer Accounting Billing (CAB) Customers**

The mechanism to make this adjustment is the same as for a faulty or dead meter. Refer to the appropriate state procedures. Note on the form the time of day bypassing started, ended, specified delivery pressure, method used to calculate the estimated amount of gas bypassed and the signature of the employee performing the work. Do not turn the index forward to make this compensation.

**5.4.2 Gas Measurement Billing (GMB) Customers**

Refer to [GS 6400.150\(CG\)](#) "Estimating and Reporting Bypassed Gas and Index Build-up."

**5.5 Shut-off, Purging and Turn On of Combination Meter Set Assemblies**

**5.5.1 CAB Meter Set Assemblies - Self-Operated Regulator(s)**

The recommended method of shutting off, purging and turning on meter set assemblies containing a meter and self-operated regulator(s) is detailed in Exhibit C.

**5.5.2 CAB Meter Set Assemblies - Pilot Operated Regulator**

The recommended method of shutting off, purging and turning on meter set assemblies containing a meter and a pilot operated control regulator is detailed in Exhibit D.

**5.5.3 GMB Meter Set Assemblies - Self-Operated Regulator(s)**

The recommended method of shutting off, purging and turning on a GMB meter set assembly containing a meter and self-operated regulator(s) is detailed in Exhibit E.

**5.6 Painting and Housekeeping**

CDC owned meter set assemblies shall be painted in accordance with the Gas Facilities Committee's Document No. 1, "Standard Paint Color Manual."

Meter set assemblies shall be painted prior to being placed in service. Subsequently, they shall be maintained in accordance with good house-keeping practices.



Distribution Operations

|                               |   |   |
|-------------------------------|---|---|
| Effective Date:<br>10/31/1991 | <b>Installation and Operations<br/>Requirements for Large Volume<br/>CAB and GMB Meter Set<br/>Assemblies</b> | Standard Number:<br><b>GS 6400.030(CG)</b><br>P&P 724-3 |
| Supersedes:<br>N/A            |   | Page 9 of 30  |

A building and a fenced area and its accesses shall be kept clear of any material unrelated to the station's operation (paint cans, brushes, thinner, lumber, ladders, etc.) to prevent a potential operating hazard of fire or explosion or unsafe working conditions.

**6. PREVENTION OF ACCIDENTAL IGNITION**

Appropriate action shall be taken to minimize the danger of accidental ignition of gas in any structure or area where the presence of gas constitutes a hazard of fire or explosion, including the following:

- a. Prior to introducing any source of ignition in any structure or area, tests shall be conducted to assure that a hazardous atmosphere is not present.
- b. Gas and electric welding and cutting shall be done in accordance with applicable safety procedures.
- c. An insulated meter setting which is installed inside a building and is insulated above ground shall have bonding cables installed to provide a path for the current around the insulated portion whenever the work performed (breaking of metallic continuity, e.g., parting of a flange, piping, tubing, etc.) may cause an electrical arcing. Bonding clamps are not required during work on customer's premises unless local conditions dictate otherwise. The method of connecting the bonding cables is shown in Exhibit F. A #8 AWG flexible wire is the minimum size bonding wire to be used for bonding. A #2 AWG flexible wire is the minimum size wire to be used when bonding in stray current areas, or in the proximity of high voltage power lines.
- d. Smoking, matches and open lights shall be prohibited in and around a structure or fenced area containing gas facilities. These areas shall be identified by a sign, Form C 1904, "Caution Decal for Regulator Buildings," Exhibit G.
- e. Flashlights or hand lanterns used in such locations shall be a type approved for the use in hazardous areas.

**7. SAFETY PRECAUTIONS**

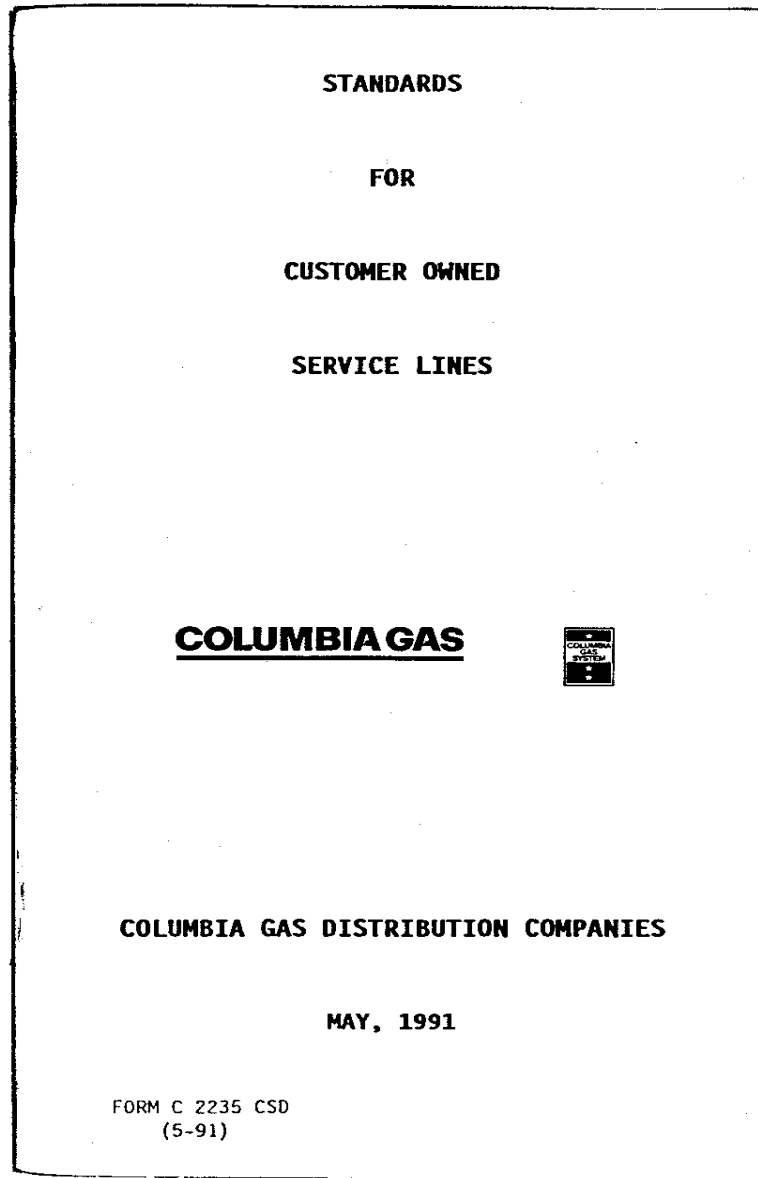
Safety practices as described in Policy and Procedure Reference Series 400 and GS Series 4000 shall be followed.



Distribution Operations

|                               |   |   |
|-------------------------------|---|---|
| Effective Date:<br>10/31/1991 | <b>Installation and Operations<br/>Requirements for Large Volume<br/>CAB and GMB Meter Set<br/>Assemblies</b> | Standard Number:<br><b>GS 6400.030(CG)</b><br>P&P 724-3 |
| Supersedes:<br>N/A            |   | Page 10 of 30   |

**EXHIBIT A**

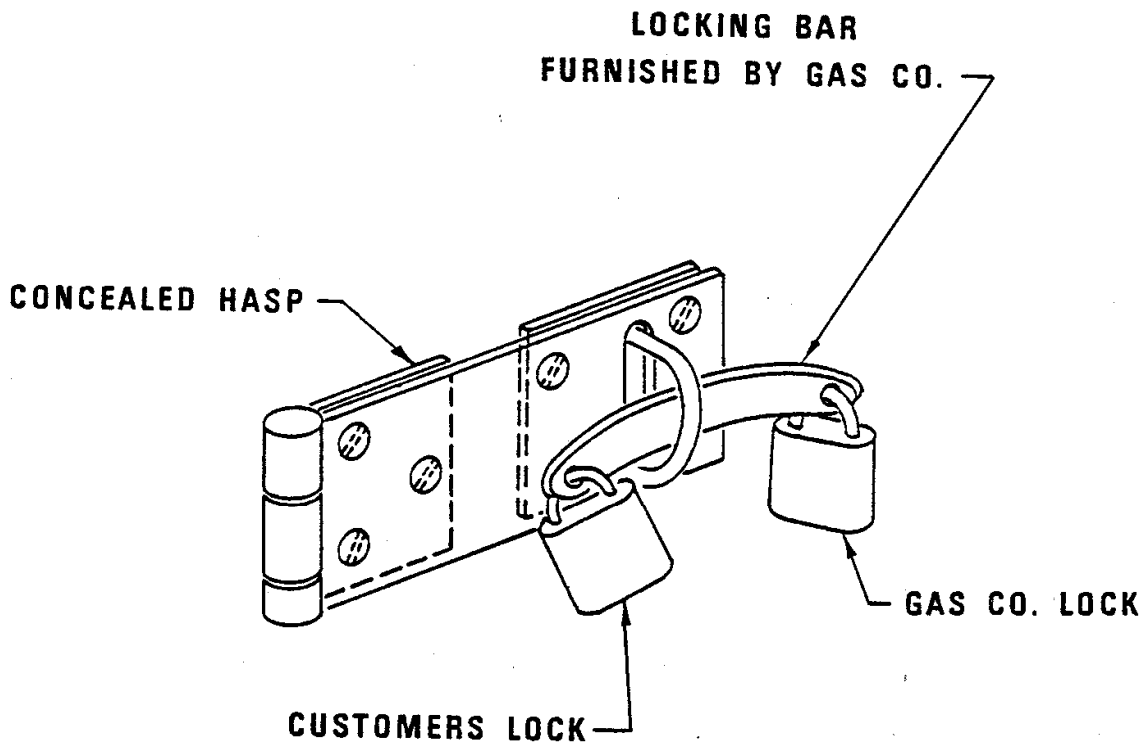




Distribution Operations

|                               |   |   |
|-------------------------------|---|---|
| Effective Date:<br>10/31/1991 | <b>Installation and Operations<br/>Requirements for Large Volume<br/>CAB and GMB Meter Set<br/>Assemblies</b> | Standard Number:<br><b>GS 6400.030(CG)</b><br>P&P 724-3 |
| Supersedes:<br>N/A            |   | Page 11 of 30   |

**EXHIBIT B**



**COMPANY & CUSTOMER DUAL LOCKING SYSTEM**

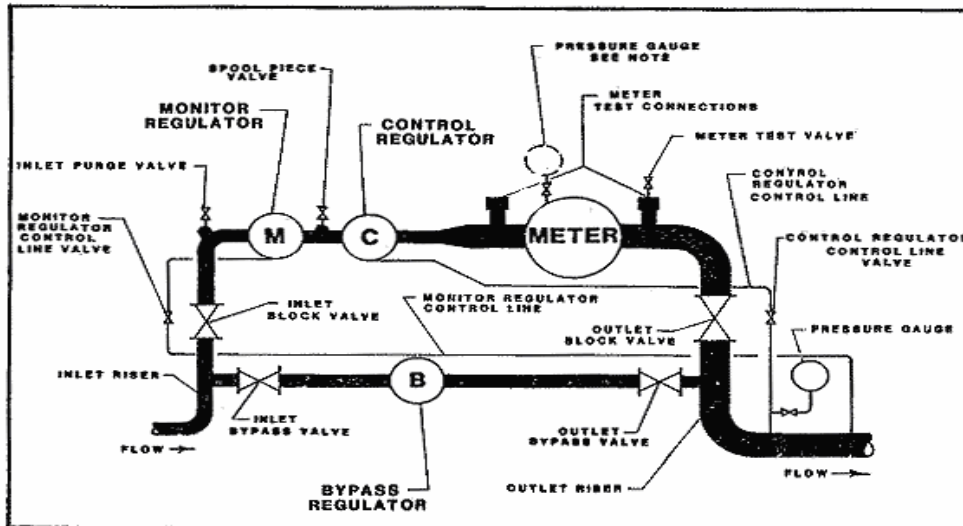


Distribution Operations

|                               |   |   |
|-------------------------------|---|---|
| Effective Date:<br>10/31/1991 | <b>Installation and Operations<br/>Requirements for Large Volume<br/>CAB and GMB Meter Set<br/>Assemblies</b> | Standard Number:<br><b>GS 6400.030(CG)</b><br>P&P 724-3 |
| Supersedes:<br>N/A            |   | Page 12 of 30   |

**EXHIBIT C  
(1 of 6)**

**PROCEDURE TO SHUT OFF, PURGE AND TURN ON A  
METER SET ASSEMBLY CONTAINING  
A METER AND SELF-OPERATED REGULATOR(S)**



It may become necessary to bypass the entire setting when preparing to work on a meter and/or regulator in a combination meter set assembly. If a bypass regulator is installed, usually one person is capable of performing the bypassing operation and the subsequent meter/regulator work. If only a valve is installed in the bypass, usually one person will operate this valve and maintain the customer service pressure while a second person performs the necessary meter/regulator maintenance work.

If, during the inspection or maintenance of a meter or regulator, the bypassed gas or index build-up would result in a billing adjustment in excess of one Mscf (one thousand standard cubic feet), an estimate of the gas bypassed is required. Refer to [GS 6400.150\(CG\)](#) "Estimating and Reporting Bypassed Gas and Index Build-up." In CAB stations the mechanism to make this adjustment is the same as for a faulty or dead meter. Refer to the appropriate state [Procedure No. 860-12, "Billing of Consumption Resulting From a Faulty or Dead Meter or Remote Index - \(General\)."](#) Note on the form the time bypassing started, ended, specified delivery pressure, method used to calculate the estimated amount of gas bypassed and the signature of the employee performing the work. Do not turn index forward to make this compensation.



Distribution Operations

|                               |   |   |
|-------------------------------|---|---|
| Effective Date:<br>10/31/1991 | <b>Installation and Operations<br/>Requirements for Large Volume<br/>CAB and GMB Meter Set<br/>Assemblies</b> | Standard Number:<br><b>GS 6400.030(CG)</b><br>P&P 724-3 |
| Supersedes:<br>N/A            |   | Page 13 of 30   |

**EXHIBIT C  
(2 of 6)**

The depressurization, purging and pressurization of a meter shall be done slowly to prevent damage to the moving parts of the meter caused by excessive acceleration.

Shutting Off The Meter Set Assembly

Shut Off  
Steps

Procedure

1. Install a pressure gauge on the control regulator control line or at a point on the downstream piping to enable the continuous observation and monitoring of the customer's service pressure. Note and maintain this pressure while bypassing. Do not install this pressure gauge on the outlet side of the bypass because false pressure readings may result at some flowing conditions.

Write down the time of day, meter index reading and the rate of flow (cubic feet per hour) passing through the meter at the beginning of bypassing.

$$\text{Cubic Feet Per Hour} = \frac{\text{Cubic Feet per Revolution of Timed Index Dial} \times 3600}{\text{Seconds Obtained Per Revolution of Index Dial (Read on Watch)}}$$

2. Back off the spring adjustment screw on the bypass regulator until the inner valve of the regulator will assume a closed position. The outlet bypass valve is normally left in an open position. Slowly open the inlet bypass valve.
3. While observing the pressure gauge reflecting the customer's service pressure, turn the spring adjustment screw down on the bypass regulator until gas is passing through the bypass. This will usually occur at a slightly higher customer service pressure.
4. Slowly turn the inlet block valve to a closed position while observing the pressure gauge to assure that the customer's service pressure is being maintained.
5. Slowly turn the outlet block valve to a closed position.





Distribution Operations

|                               |  |   |
|-------------------------------|--|---|
| Effective Date:<br>10/31/1991 | <b>Installation and Operations<br/>                 Requirements for Large Volume<br/>                 CAB and GMB Meter Set<br/>                 Assemblies</b> | Standard Number:<br><b>GS 6400.030(CG)</b><br>P&P 724-3 |
| Supersedes:<br>N/A            |  | Page 14 of 30   |

**EXHIBIT C  
 (3 of 6)**

6. Close control and monitor regulator control line valves, if so equipped, then disconnect the control lines at the regulator(s) and depressurize lines. The regulators are now in an open position.
7. Slowly open meter test valve and depressurize the entire setting.
8. Observe the pressure gauge, and if necessary, adjust the bypass regulator to the specified delivery pressure. Normally, this will require backing off the spring adjustment screw.

Purging The Meter Set Assembly

Purging Steps

Procedure

9. The meter/regulator is ready for inspection and/or maintenance.  
  
 Prior to purging it is assumed that the work has been completed on the meter and/or regulator. The meter set assembly is being bypassed and the downstream pressure monitored using a pressure gauge. The purging process shall proceed through the meter (upstream to downstream).
10. Check to assure that the following setting valves are closed: inlet block valve, outlet block valve, control regulator control line valve, monitor regulator control line valve and spool piece valve.
11. Open the inlet purge valve and the meter test valve.
12. Back off the spring adjustment screw on the monitor regulator until the inner valve of the regulator will assume a closed position when pressure is again applied to the monitor regulator control line.



Distribution Operations

|                               |   |   |
|-------------------------------|---|---|
| Effective Date:<br>10/31/1991 | <b>Installation and Operations<br/>Requirements for Large Volume<br/>CAB and GMB Meter Set<br/>Assemblies</b> | Standard Number:<br><b>GS 6400.030(CG)</b><br>P&P 724-3 |
| Supersedes:<br>N/A            |   | Page 15 of 30   |

**EXHIBIT C  
(4 of 6)**

13. Open the monitor regulator control line valve and purge until a strong gas odor is noted at the outlet (union or fitting) of the monitor regulator control line. Reconnect control line to monitor regulator and pressurize the regulator with the bypassed regulated downstream pressure. The regulator is now in a closed position.
14. If the control regulator has an external control line, open the control regulator control line valve and purge until a strong gas odor is noted at the outlet (union or fitting) of the control line. Reconnect control line to control regulator and pressurize the regulator with the bypassed regulated downstream pressure. Turn adjustment screw down on the control regulator until the inner valve is wide open.
15. If no external control line is used on the control regulator, turn adjustment screw down until the inner valve is wide open.
16. Slowly crack open the inlet block valve and bleed gas through the inlet purge valve until a strong gas odor is noted, then close the inlet purge valve. Completely open inlet block valve.
17. Slowly turn the adjustment screw down on monitor regulator and purge gas through the control regulator and the meter until a strong gas odor is noted at the meter test valve.
18. Slowly crack open the outlet block valve until an increase in the gas flow rate is detected at the meter test valve. Purge the outlet riser.



Distribution Operations

|                               |  |   |
|-------------------------------|--|---|
| Effective Date:<br>10/31/1991 | <b>Installation and Operations<br/>                 Requirements for Large Volume<br/>                 CAB and GMB Meter Set<br/>                 Assemblies</b> | Standard Number:<br><b>GS 6400.030(CG)</b><br>P&P 724-3 |
| Supersedes:<br>N/A            |  | Page 16 of 30   |

**EXHIBIT C  
 (5 of 6)**

Turning On The Meter Set Assembly

Turn On  
 Steps

Procedure

19. Close the meter test valve and allow the meter and piping to pressurize to the downstream pressure.
20. Completely open the outlet block valve.

Purging is now completed and the combination meter set assembly is ready to be turned on.

Note: When the measurement setting does not have a recording gauge (fixed pressure factor measurement and low pressure settings), the meter inlet pressure tap should be used for gauging the regulator specified delivery pressure [refer to [GS 6400.090\(CG\)](#) "Fixed Pressure Factor Metering (FPFM)]," Section 6, second paragraph). The customer delivery pressure at the outlet piping may be used to gauge the regulator set pressure for GMB measurement settings (recording pressure gauge installed).

21. Install a pressure gauge on the upstream meter pressure tap for fixed pressure factor measurement and low pressure settings (see above note).
22. Back off the spring adjustment screw on the bypass regulator until the down-stream pressure is 0.1 to 0.2 psi below the specified delivery pressure.
23. Slowly turn the adjustment screw down on the monitor regulator until the regulated pressure as observed on the pressure gauge is approximately 22 percent higher than the final specified delivery pressure (SDP). At this point the bypass regulator should have closed and all gas should be passing through the meter.

$$\text{Monitor Regulator Set Point} = 0.22 \times \text{Control Regulator Set Point (SDP)} + \text{Control Regulator Set Point (SDP)}$$

24. Slowly close the inlet bypass valve. Do not close the outlet bypass valve.



Distribution Operations

|                               |   |   |
|-------------------------------|---|---|
| Effective Date:<br>10/31/1991 | <b>Installation and Operations<br/>Requirements for Large Volume<br/>CAB and GMB Meter Set<br/>Assemblies</b> | Standard Number:<br><b>GS 6400.030(CG)</b><br>P&P 724-3 |
| Supersedes:<br>N/A            |   | Page 17 of 30   |

**EXHIBIT C  
(6 of 6)**

25. Slowly back off the spring adjustment screw on the control regulator until the specified delivery pressure is established. Lock or seal the inlet bypass valve.
26. The meter set assembly has been returned to service. Refer to [GS 6400.090\(CG\)](#) for the necessary twenty-four (24) hour initial inspection and seven (7) day initial inspection.
27. Write down the time of day and the rate of flow passing through the meter (cubic feet per hour) when bypassing completed. Determine the amount of gas bypassed (standard cubic feet) during the maintenance or test period. Assume FPFM setting operating at 10 psig.

| <u>Flow Rate (cfh)</u> | <u>Time</u> |            |
|------------------------|-------------|------------|
| End of bypassing       | 650         | 11:30 A.M. |
| Beginning of bypassing | 800         | 9:00 A.M.  |

Time difference 2 hrs. 30 min.

$$\text{Average flow rate} = \frac{650 + 800}{2} = 725 \text{ cfh at 10 psig}$$

Period of time measurement bypassed = 2.5 hours

Amount of gas bypassed = 725 x 2.5 = 1812.5 cu. ft.

$$\text{Standard cubic feet bypassed} = 1812.5 \times \frac{10 + 14.4}{14.73} = 3002 \text{ scf}$$

Since 3002 scf is greater than 1000 scf, a billing adjustment is required.

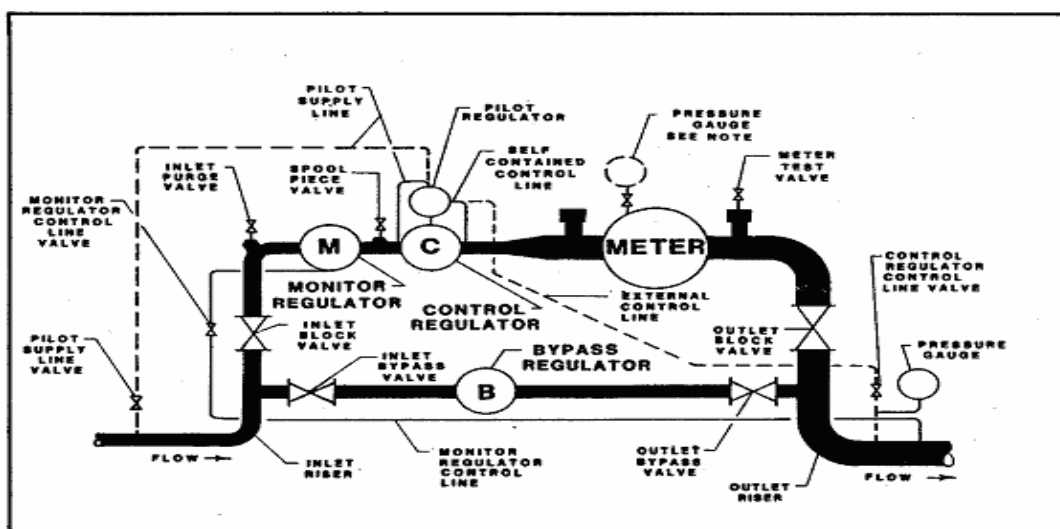


Distribution Operations

|                               |   |   |
|-------------------------------|---|---|
| Effective Date:<br>10/31/1991 | <b>Installation and Operations<br/>Requirements for Large Volume<br/>CAB and GMB Meter Set<br/>Assemblies</b> | Standard Number:<br><b>GS 6400.030(CG)</b><br>P&P 724-3 |
| Supersedes:<br>N/A            |   | Page 18 of 30   |

**EXHIBIT D  
(1 of 6)**

**PROCEDURE TO SHUT OFF, PURGE AND TURN ON A  
METER SET ASSEMBLY CONTAINING A METER,  
A SELF-OPERATED MONITOR REGULATOR AND  
A PILOT OPERATED CONTROL REGULATOR**



It may become necessary to bypass the entire setting when preparing to work on a meter and/or regulator in a combination meter set assembly. If a bypass regulator is installed, usually one person is capable of performing the bypassing operation and the subsequent meter/regulator work. If only a valve is installed in the bypass, usually one person will operate this valve and maintain the customer service pressure while a second person performs the necessary meter/regulator maintenance work.

If, during the inspection or maintenance of a meter or regulator, the bypassed gas or index build-up would result in a billing adjustment in excess of one Mscf (one thousand standard cubic feet), an estimate of the gas bypassed is required. Refer to [GS 6400.150\(CG\)](#) "Estimating and Reporting Bypassed Gas and Index Build-up." In CAB stations, the mechanism to make this adjustment is the same as for a faulty or dead meter. Refer to the appropriate state **Procedure No. 860-12, "Billing of Consumption Resulting from a Faulty or Dead Meter or Remote Index - (General)."** Note on the form the time bypassing started, ended, specified delivery pressure, method used to calculate the estimated amount of gas bypassed and the signature of the employee performing the work. Do not turn index forward to make this compensation.



Distribution Operations

|                               |  |   |
|-------------------------------|--|---|
| Effective Date:<br>10/31/1991 | <b>Installation and Operations<br/>                 Requirements for Large Volume<br/>                 CAB and GMB Meter Set<br/>                 Assemblies</b> | Standard Number:<br><b>GS 6400.030(CG)</b><br>P&P 724-3 |
| Supersedes:<br>N/A            |  | Page 19 of 30   |

**EXHIBIT D  
 (2 of 6)**

The depressurization, purging and pressurization of a meter set assembly shall be done slowly to prevent damage to the moving parts of the meter caused by excessive acceleration.

Shutting Off The Meter Set Assembly

Shut Off  
 Steps

Procedure

1. Install a pressure gauge on the control regulator control line or at a point on the downstream piping to enable the continuous observation and monitoring of the customer's service pressure. Note and maintain this pressure while bypassing. Do not install this pressure gauge on the outlet side of the bypass because false pressure readings may result at some flowing conditions.

Write down the time of day, meter index reading and the rate of flow (cubic feet per hour) passing through the meter at the beginning of bypassing.

$$\text{Cubic Feet Per Hour} = \frac{\text{Cubic Feet Per Revolution of Timed Index Dial} \times 3600}{\text{Seconds Obtained Per Revolution of Index Dial (Read on Watch)}}$$

2. Back off the spring adjustment screw on the bypass regulator until the inner valve of the regulator will assume a closed position. The outlet bypass valve is normally left in an open position. Slowly open the inlet bypass valve.
3. While observing the pressure gauge reflecting the customer's service pressure, turn the spring adjustment screw down on the bypass regulator until gas is passing through the bypass. This will usually occur at a slightly higher customer service pressure.
4. Slowly turn the inlet block valve to a closed position while observing the pressure gauge to assure that the customer's service pressure is being maintained.
5. Slowly turn the outlet block valve to a closed position. Close the external pilot supply line valve (if so equipped).



Distribution Operations

|                               |  |   |
|-------------------------------|--|---|
| Effective Date:<br>10/31/1991 | <b>Installation and Operations<br/>                 Requirements for Large Volume<br/>                 CAB and GMB Meter Set<br/>                 Assemblies</b> | Standard Number:<br><b>GS 6400.030(CG)</b><br>P&P 724-3 |
| Supersedes:<br>N/A            |  | Page 20 of 30   |

**EXHIBIT D  
 (3 of 6)**

6. Close control and monitor regulator control line valves, if so equipped, then unscrew the control lines at the regulator connections and depressurize the lines. If the pilot operated control regulator is of the self-contained type (no external control line and valve), screw down the pressure adjustment screw on the pilot regulator and slowly open the pilot supply line valve, if so equipped. The valves of the monitor and control regulators are now in an open position.
7. Slowly open meter test valve and depressurize the entire setting. Close the external pilot supply line valve, then unscrew the line at the pilot regulator connection and depressurize the line (if so equipped).
8. Observe the pressure gauge, and if necessary, adjust the bypass regulator to the specified delivery pressure. Normally, this will require backing off the spring adjustment screw.
9. The meter/regulator is ready for inspection or maintenance.

Prior to purging it is assumed that the work has been completed on the meter and/or regulator. The meter set assembly is being bypassed and the down-stream pressure monitored using a pressure gauge. The purging process shall proceed through the meter (upstream to downstream).

Purging The Meter Set Assembly

Purging  
 Steps

Procedure

10. Check to assure that the following setting valves are closed: inlet block valve, outlet block valve, monitor regulator control line valve, control regulator control line valve (if so equipped), pilot supply line valve (if so equipped), inlet purge valve and spool piece valve.
11. Open meter test valve.



Distribution Operations

|                               |   |   |
|-------------------------------|---|---|
| Effective Date:<br>10/31/1991 | <b>Installation and Operations<br/>Requirements for Large Volume<br/>CAB and GMB Meter Set<br/>Assemblies</b> | Standard Number:<br><b>GS 6400.030(CG)</b><br>P&P 724-3 |
| Supersedes:<br>N/A            |   | Page 21 of 30   |

**EXHIBIT D  
(4 of 6)**

12. Back off the spring adjustment screw on the monitor regulator. Open the monitor regulator control line valve and purge until a strong gas odor is noted at the outlet of the monitor regulator control line. Reconnect monitor regulator control line and pressurize (open valve) the regulator with the regulated downstream pressure. The monitor regulator is now in a closed position.
13. If the control regulator has an external control line, open the control regulator control line valve and purge until a strong gas odor is noted at the outlet (union or fitting) of the control line. Reconnect the control line to the control regulator and pressurize with the bypassed regulated downstream pressure. The regulator is in a closed position. If the control regulator has an external pilot supply line, slowly open the valve and purge until a strong gas odor is noted at the outlet of the supply line. Reconnect the supply line to the pilot regulator and pressurize the line to the upstream pressure. Turn adjustment screw down on the control pilot regulator until the inner valve will assume a wide open position. Step 6 has the inner valve of a self contained control regulator in an open position.
14. Slowly crack open, the inlet block valve and pressurize the inlet piping to the monitor regulator. Completely open the inlet block valve.
15. Slowly turn adjustment screw down on monitor regulator and purge gas through the pilot operated control regulator and the meter until a strong gas odor is noted at the meter test valve.
16. Slowly crack open the outlet block valve until an increase in the gas flow rate is detected at the meter test valve. Purge the outlet riser.
17. Close the meter test valve and allow the meter and piping to pressurize to the downstream pressure.
18. Completely open the outlet block valve.

Purging is now completed and the combination meter set assembly is ready to be turned on.





Distribution Operations

|                               |   |   |
|-------------------------------|---|---|
| Effective Date:<br>10/31/1991 | <b>Installation and Operations<br/>Requirements for Large Volume<br/>CAB and GMB Meter Set<br/>Assemblies</b> | Standard Number:<br><b>GS 6400.030(CG)</b><br>P&P 724-3 |
| Supersedes:<br>N/A            |   | Page 22 of 30   |

**EXHIBIT D  
(5 of 6)**

Turning On The Meter Set Assembly

Turn On  
Steps

Procedure

Note: When the measurement setting does not have a recording gauge (fixed pressure factor measurement and low pressure settings), the meter inlet pressure tap should be used for gauging the regulator specified delivery pressure [refer to [GS 6400.090\(CG\)](#) "Fixed Pressure Factor Metering (FPFM)"]. The customer delivery pressure at the outlet piping may be used to gauge the regulator set pressure for GMB measurement settings (recording pressure gauge installed).

19. Install a pressure gauge on the upstream meter pressure tap for fixed pressure factor measurement and low pressure settings (see above note).
20. Back off the spring adjustment screw on the bypass regulator until the downstream pressure is 0.1 to 0.2 psi below the specified delivery pressure.
21. Slowly turn the adjustment screw down on the monitor regulator until the regulated pressure is approximately 22 percent higher than the final specified delivery pressure (SDP). At this point the bypass regulator should have closed and all gas should be passing through the meter.

$$\text{Monitor Regulator Set Point} = 0.22 \times \text{Control Regulator Set Point (SDP)} + \text{Control Regulator Set Point (SDP)}$$

22. Slowly close the inlet bypass valve. Do not close the outlet bypass valve.
23. Slowly back off the spring adjustment screw on the pilot of the control regulator until the specified delivery pressure is established. Lock or seal the inlet bypass valve.
24. The meter set assembly has been returned to service. Refer to [GS 6400.090\(CG\)](#) for the necessary twenty-four (24) hour initial inspection and seven (7) day initial inspection.



Distribution Operations

|                               |   |   |
|-------------------------------|---|---|
| Effective Date:<br>10/31/1991 | <b>Installation and Operations<br/>Requirements for Large Volume<br/>CAB and GMB Meter Set<br/>Assemblies</b> | Standard Number:<br><b>GS 6400.030(CG)</b><br>P&P 724-3 |
| Supersedes:<br>N/A            |   | Page 23 of 30   |

**EXHIBIT D  
(6 of 6)**

25. Write down the time of day and the rate of flow passing through the meter (cubic feet per hour) when bypassing is completed.
26. Determine the amount of gas bypassed during the maintenance or test period. Assume FPFM setting operating at 2 psig.

|                        | <u>Flow Rate (cfh)</u> | <u>Time</u> |
|------------------------|------------------------|-------------|
| End of bypassing       | 8200                   | 1:45 P.M.   |
| Beginning of bypassing | 8000                   | 1:00 P.M.   |

Time Difference 0 hr. 45 min.

$$\text{Average flow rate} = \frac{8200 + 8000}{2} = 8100 \text{ cfh at 2 psig}$$

$$\text{Period of time measurement bypassed} = \frac{45}{60} = 0.75 \text{ hours}$$

$$\text{Amount of gas bypassed} = 8100 \times 0.75 = 6075 \text{ cu. ft.}$$

$$\text{Standard cubic feet bypassed} = 6075 \times \frac{2 + 14.4}{14.73} = 6763 \text{ scf.}$$

Since 6763 scf is greater than 1000 scf, a billing adjustment is required.

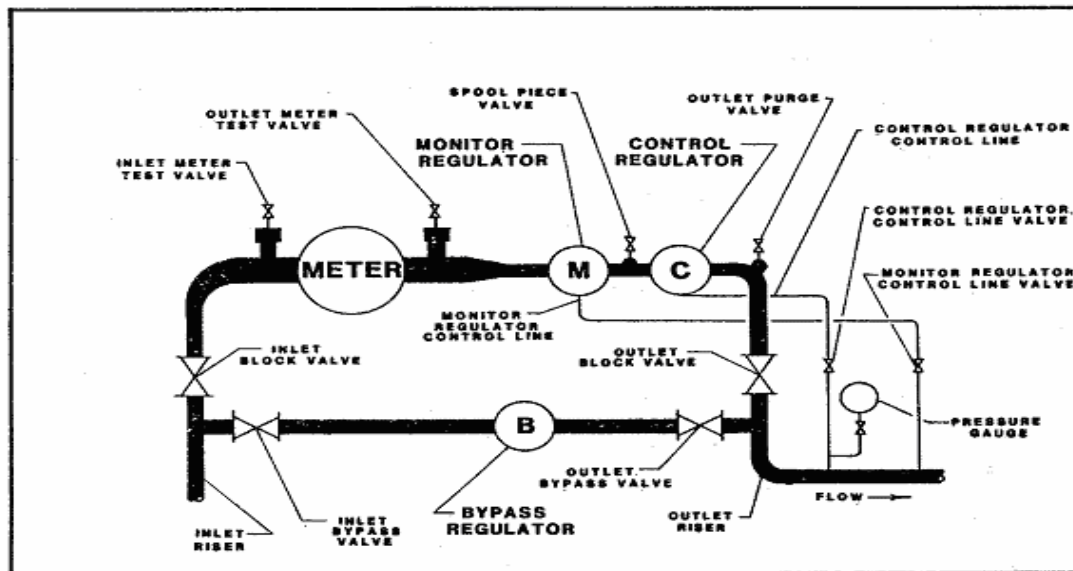


Distribution Operations

|                               |   |   |
|-------------------------------|---|---|
| Effective Date:<br>10/31/1991 | <b>Installation and Operations<br/>Requirements for Large Volume<br/>CAB and GMB Meter Set<br/>Assemblies</b> | Standard Number:<br><b>GS 6400.030(CG)</b><br>P&P 724-3 |
| Supersedes:<br>N/A            |   | Page 24 of 30   |

**EXHIBIT E  
(1 of 5)**

**PROCEDURE TO SHUT OFF, PURGE AND TURN ON A GAS  
MEASUREMENT BILLING (GMB) METER SET  
ASSEMBLY CONTAINING A METER AND  
SELF-OPERATED REGULATORS**



It may become necessary to bypass the entire setting when preparing to work on a meter and/or regulator in a combination meter set assembly. If a bypass regulator is installed, usually one person is capable of performing the bypassing operation and the subsequent meter/regulator work. If only a valve is installed in the bypass, usually one person will operate this valve and maintain the customer service pressure while a second person performs the necessary meter/regulator maintenance work.

If, during the inspection or maintenance of a meter or regulator, the bypassed gas or index build-up would result in a billing adjustment in excess of one Mscf (one thousand standard cubic feet), an estimate of the gas bypassed is required. Refer to [GS 6400.150\(CG\)](#) "Estimating and Reporting Bypassed Gas and Index Build-up."

The depressurization, purging and pressurization of a meter set assembly shall be done slowly to prevent damage to the moving parts of the meter caused by excessive acceleration.



Distribution Operations

|                               |  |   |
|-------------------------------|--|---|
| Effective Date:<br>10/31/1991 | <b>Installation and Operations<br/>                 Requirements for Large Volume<br/>                 CAB and GMB Meter Set<br/>                 Assemblies</b> | Standard Number:<br><b>GS 6400.030(CG)</b><br>P&P 724-3 |
| Supersedes:<br>N/A            |  | Page 25 of 30   |

**EXHIBIT E  
 (2 of 5)**

Shutting Off The Meter Set Assembly

Shut Off  
 Steps

Procedure

1. Install a pressure gauge on the control regulator control line or at a point on the downstream piping to enable the continuous observation and monitoring of the customer's service pressure. Note and maintain this pressure while bypassing. Do not install this pressure gauge on the outlet side of the bypass because false pressure readings may result at some flowing conditions.

Write on meter test report time of day, meter index reading (corrected and uncorrected), gas temperature, pressure and flow rate at the beginning of bypassing.

$$\text{Cubic Feet Per Hour} = \frac{\text{Cubic Feet Per Revolution of Timed Index Dial} \times 3600}{\text{Seconds Obtained Per Revolution of Index Dial (Read on Watch)}}$$

2. Back off the spring adjustment screw on the bypass regulator until the inner valve of the regulator will assume a closed position. The outlet bypass valve is normally left in an open position. Slowly open the inlet bypass valve.
3. While observing the pressure gauge reflecting the customer's service pressure, turn the spring adjustment screw down on the bypass regulator until gas is passing through the bypass. This will usually occur at a slightly higher customer service pressure.
4. Slowly turn the inlet block valve to a closed position while observing the pressure gauge to assure that the customer's service pressure is being maintained.
5. Slowly turn the outlet block valve to a closed position.
6. Close control and monitor regulator control line valves, if so equipped, then unscrew the control lines at the regulator connections and depressurize the lines. When a self-operated regulator is installed without a control line, screw down the spring adjustment screw. The valves of the monitor and control regulators are now in an open position.



Distribution Operations

|                               |  |   |
|-------------------------------|--|---|
| Effective Date:<br>10/31/1991 | <b>Installation and Operations<br/>                 Requirements for Large Volume<br/>                 CAB and GMB Meter Set<br/>                 Assemblies</b> | Standard Number:<br><b>GS 6400.030(CG)</b><br>P&P 724-3 |
| Supersedes:<br>N/A            |  | Page 26 of 30   |

**EXHIBIT E  
 (3 of 5)**

7. Slowly open outlet purge valve and depressurize the entire setting.
8. Observe the pressure gauge, and if necessary, adjust the bypass regulator to the customer's delivery pressure.
9. The meter/regulator is ready for inspection and/or maintenance.

Prior to purging it is assumed that the work has been completed on the meter and/or regulator. The meter set assembly is being bypassed and the downstream pressure monitored using a pressure gauge. The purging process shall proceed through the meter (upstream to downstream).

Purging The Meter Set Assembly

Purging Steps

Procedure

10. Check to assure that the following setting valves are closed: inlet block valve, outlet block valve, control regulator control line valve (if so equipped), monitor regulator control line valve, spool piece valve and outlet purge valve.
11. Open the inlet meter test valve and the outlet meter test valve.
12. Open the monitor control line valve and purge until a strong gas odor is noted at the outlet (union or fitting) of the monitor control line. Reconnect control line to monitor regulator and pressurize the regulator with the bypassed regulated downstream pressure. Back off the spring adjustment screw to assure that the inner valve of the regulator is in a closed position.
13. If the control regulator has an external control line, open the control line valve and purge until a strong gas odor is noted at the outlet (union or fitting) of the control line. Reconnect control line to control regulator and pressurize the regulator with the bypassed regulated downstream pressure. The regulator is in a closed position. Turn spring adjustment screw down on the control regulator until the inner valve is wide open.



Distribution Operations

|                               |  |   |
|-------------------------------|--|---|
| Effective Date:<br>10/31/1991 | <b>Installation and Operations<br/>                 Requirements for Large Volume<br/>                 CAB and GMB Meter Set<br/>                 Assemblies</b> | Standard Number:<br><b>GS 6400.030(CG)</b><br>P&P 724-3 |
| Supersedes:<br>N/A            |  | Page 27 of 30   |

**EXHIBIT E  
 (4 of 5)**

14. If no external control line is used on the control regulator, turn spring adjustment screw down until the inner valve is wide open. See Step 6.
15. Slowly crack open the inlet block valve and purge gas through the inlet meter test valve, meter and outlet meter test valve. Close the inlet test valve as soon as a strong gas odor is noted at the valve. Slowly close the outlet meter test valve to control the pressurizing of the meter. When the meter is pressurized to full line pressure, completely open the inlet block valve.
16. Turn spring adjustment screw down on monitor regulator and purge gas through the control regulator until a strong gas odor is noted at the outlet purge valve.
17. Slowly crack open the outlet block valve until an increase in the gas flow rate is detected at the outlet purge valve. Purge the outlet riser.
18. Close the outlet purge valve and allow the regulator and piping to pressurize to the regulated downstream pressure. Completely open outlet block valve.

Purging is now completed and the meter set assembly is ready to be turned on.

Turning On The Meter Set Assembly

Turn On  
 Steps

Procedure

Note: The customer delivery pressure at the outlet piping may be used to gauge the regulator set pressure for GMB measurement settings (recording pressure gauge installed).

19. Back off the spring adjustment screw on the bypass regulator until the downstream pressure is 0.1 to 0.2 psig below the customer delivery pressure.



Distribution Operations

|                               |   |   |
|-------------------------------|---|---|
| Effective Date:<br>10/31/1991 | <b>Installation and Operations<br/>Requirements for Large Volume<br/>CAB and GMB Meter Set<br/>Assemblies</b> | Standard Number:<br><b>GS 6400.030(CG)</b><br>P&P 724-3 |
| Supersedes:<br>N/A            |   | Page 28 of 30   |

**EXHIBIT E  
(5 of 5)**

20. Slowly turn the adjustment screw down on the monitor regulator until the regulated pressure is approximately 22 percent higher than the final customer delivery pressure (CDP). At this point the bypass regulator should have closed and all the gas should be passing through the meter.

$$\text{Monitor Regulator Set Point} = 0.22 \times \text{Control Regulator Set Point (CDP)} + \text{Control Regulator Set Point (CDP)}$$

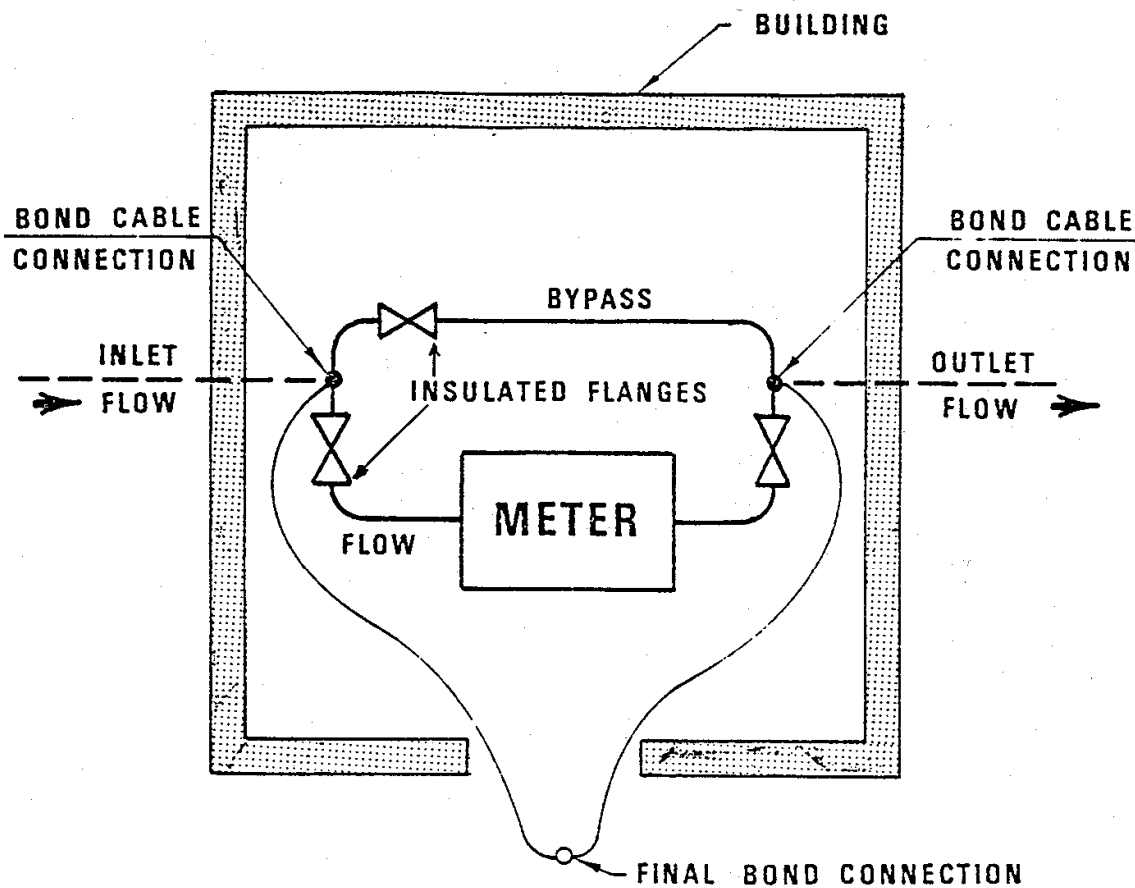
21. Slowly close the inlet bypass valve. Do not close the outlet bypass valve.
22. Slowly back off the spring adjustment screw of the self-operated control regulator until the customer delivery pressure is established. Lock or seal the inlet bypass valve.
23. The meter set assembly is now turned on.
24. Write on meter test report time of day, meter index reading (correct and incorrect), gas temperature, pressure and flow rate at end of bypassing.



Distribution Operations

|                               |   |   |
|-------------------------------|---|---|
| Effective Date:<br>10/31/1991 | <b>Installation and Operations<br/>Requirements for Large Volume<br/>CAB and GMB Meter Set<br/>Assemblies</b> | Standard Number:<br><b>GS 6400.030(CG)</b><br>P&P 724-3 |
| Supersedes:<br>N/A            |   | Page 29 of 30   |

EXHIBIT F



BONDING CABLE CONNECTIONS FOR  
INSULATED METER SETTINGS





Distribution Operations

|                               |   |   |
|-------------------------------|---|---|
| Effective Date:<br>10/31/1991 | <b>Installation and Operations<br/>Requirements for Large Volume<br/>CAB and GMB Meter Set<br/>Assemblies</b> | Standard Number:<br><b>GS 6400.030(CG)</b><br>P&P 724-3 |
| Supersedes:<br>N/A            |   | Page 30 of 30   |

EXHIBIT G





Distribution Operations

|                               |  |   |
|-------------------------------|--|---|
| Effective Date:<br>12/08/2006 | <b>Meter Change Policy - Diaphragm</b> | Standard Number:<br><b>GS 6400.040(CG)</b><br>P&P 724-4 |
| Supersedes:<br>N/A            |  | Page 1 of 2   |

Companies Affected:

|                                     |   |   |
|-------------------------------------|---|---|
| <input type="checkbox"/> NIPSCO     | <input checked="" type="checkbox"/> CGV | <input checked="" type="checkbox"/> CMD |
| <input type="checkbox"/> NIFL       | <input checked="" type="checkbox"/> CKY | <input checked="" type="checkbox"/> COH |
| <input type="checkbox"/> Kokomo Gas | <input type="checkbox"/> CMA            | <input checked="" type="checkbox"/> CPA |

**REFERENCE**    None

**1. GENERAL REQUIREMENTS**

Each operating Company shall establish a sampling program or a periodic meter change program in conformance with applicable state rules and regulations. Exhibit A provides the meter program for each state and meter classification.

Meters that are removed from service should be returned to a meter shop for testing. Larger meters may be field tested prior to disposal, with the meter test information being forwarded to appropriate personnel for data entry.

**2. REASONS FOR CHANGING METERS**

- a. Program Changes - Those meters scheduled for program change.
- b. Meter Change (Cause) - Those meters which are changed for leakage, do not register properly, do not pass gas, are noisy, or are in a damaged condition.
- c. Meter Change (Inactive) - The inactive meter may remain in place for up to 12 months, at which time an order to remove the meter will be issued. The meter may continue to remain in place if circumstances indicate it is appropriate.
- d. Meter Change (Size) - Meters that are not properly sized for the current load requirements.

**3. METER DATABASE MAINTENANCE**

In order to maintain the accuracy of the meter database, Meter Change Orders shall be executed in a timely and appropriate manner.

*This document is considered CONTROLLED only when viewed electronically on the Company's intranet. Printed or other electronic copies may not be current, and the intranet version should be used to verify.*



Distribution Operations

|                               |  |   |
|-------------------------------|--|---|
| Effective Date:<br>12/08/2006 | <b>Meter Change Policy - Diaphragm</b> | Standard Number:<br><b>GS 6400.040(CG)</b><br>P&P 724-4 |
| Supersedes:<br>N/A            |  | Page 2 of 2   |

**EXHIBIT A**

DIAPHRAGM METER TEST/CHANGE PROGRAM SCHEDULE

| <u>COMPANY</u>     | <u>RATED CAPACITY, [CFH]</u> | <u>TEST/CHANGE PERIOD, [YEARS]</u> |
|--------------------|------------------------------|------------------------------------|
| CKY 0 – 1500       |                              | Sampling*                          |
|                    | Over 1500                    | 2**                                |
| CMD All meters     |                              | Per state commission regulations   |
| COH 1000 and Under |                              | Sampling                           |
|                    | Over 1000                    | Sampling                           |
| CPA All meters     |                              | Per state commission regulations   |
| CGV 0 – 1000       |                              | Sampling                           |
|                    | Over 1000                    | Sampling                           |

\* On February 26, 2001, CKY was granted authority to deviate from Kentucky Public Service Commission regulation 807 KAR 5:006, Section 25(5)(b) (Case #2000-429).

\*\* On January 7, 1986, CKY was granted a deviation from Kentucky Public Service Commission regulation 807 KAR 5:022, Section 8(5)(a)1 and 3 (Case #9491).



Distribution Operations

|                               |                                     |   |
|-------------------------------|-------------------------------------|---|
| Effective Date:<br>04/02/1986 | <b>Remote Meter Reading Devices</b> | Standard Number:<br><b>GS 6400.060(CG)</b><br>P&P 724-6 |
| Supersedes:<br>N/A            |                                     | Page 1 of 2   |

Companies Affected:

|                                     |   |   |
|-------------------------------------|---|---|
| <input type="checkbox"/> NIPSCO     | <input checked="" type="checkbox"/> CGV | <input checked="" type="checkbox"/> CMD |
| <input type="checkbox"/> NIFL       | <input checked="" type="checkbox"/> CKY | <input checked="" type="checkbox"/> COH |
| <input type="checkbox"/> Kokomo Gas | <input type="checkbox"/> CMA            | <input checked="" type="checkbox"/> CPA |

**REFERENCE**    None

**1. GENERAL**

Remote meter reading devices are available for installation in those instances where it is difficult to obtain a reading of the customer's meter. The customer will be billed for the installation of the remote meter reading device. This installation will normally be made for the convenience of the customer and should be explained in this manner when suggested to a customer. These devices should be used only on domestic size low pressure meter installations (connections under 2 inch).

**2. COST TO THE CUSTOMER**

Unless a charge for the installation of a remote meter reading device has been established in the Rules and Regulations or Tariff on file with a state commission, the customer will be billed for the installation of a remote meter reading device at the flat rate of \$40.00 per device.

**3. ACCOUNTING FOR THE REMOTE METER READING DEVICE**

When purchased, these devices will be charged to account 893-3246. The units that will be shipped from the meter shop will already be charged out to 893-3246 on a pro rated percentage by location.

**4. ACCOUNTING FOR THE INSTALLATION OF THE REMOTE METER READING DEVICE**

Labor and material charges for the initial installation of the remote reading devices will be charged as follows:

- a. Labor and material involved in changing the meter shall be charged to Account 878-3212-Loc. No.
- b. Labor and material involved in installing the remote meter reading device shall be charged to Account 879-3414-Loc. No.

*This document is considered CONTROLLED only when viewed electronically on the Company's intranet. Printed or other electronic copies may not be current, and the intranet version should be used to verify.*



**Gas Standard**

Distribution Operations

|                               |                                     |   |
|-------------------------------|-------------------------------------|---|
| Effective Date:<br>04/02/1986 | <b>Remote Meter Reading Devices</b> | Standard Number:<br><b>GS 6400.060(CG)</b><br>P&P 724-6 |
| Supersedes:<br>N/A            |                                     | Page 2 of 2   |

Labor and material charges for the replacement of a remote meter reading device shall be charged to Account 893-3246-Loc. No.



**Gas Standard**

Distribution Operations

|                               |                      |   |
|-------------------------------|----------------------|---|
| Effective Date:<br>12/07/1993 | <b>Meter Records</b> | Standard Number:<br><b>GS 6400.070(CG)</b><br>P&P 724-7 |
| Supersedes:<br>N/A            |                      | Page 1 of 29  |

Companies Affected:

|                                     |   |   |
|-------------------------------------|---|---|
| <input type="checkbox"/> NIPSCO     | <input checked="" type="checkbox"/> CGV | <input checked="" type="checkbox"/> CMD |
| <input type="checkbox"/> NIFL       | <input checked="" type="checkbox"/> CKY | <input checked="" type="checkbox"/> COH |
| <input type="checkbox"/> Kokomo Gas | <input type="checkbox"/> CMA            | <input checked="" type="checkbox"/> CPA |

**REFERENCE None**

**1. GENERAL**

This procedure provides the methods to:

- a. record meter data that identifies meters removed from or placed on customer premises,
- b. record test data for the analysis of meter performance, and
- c. record the permanent history of the meter's use.

**2. METER RECORDS**

**2.1 Meter Record Card**

The Meter Record Card, (Exhibit A), is a two part card which is completed and attached to the meter at the time of the meter's removal from the customer premise. The two parts of the Meter Record Card are called the Tag section and Meter Record section. The following Meter Record Card form numbers are applicable to each Company, as indicated:

| <u>Form Number</u>        | <u>Company</u>              | <u>Form Color</u>    |
|---------------------------|-----------------------------|----------------------|
| C 1759 CKY                | Pink with Black Ink         |                      |
| C 1760 CMD                | Blue with Black Ink         |                      |
| C 1762                    | CPA (except York & Hanover) | White with Black Ink |
| C 1763 CPA (York-Hanover) |                             | White with Green Ink |
| C 1766 COS                |                             | White with Red Ink   |

*This document is considered CONTROLLED only when viewed electronically on the Company's intranet. Printed or other electronic copies may not be current, and the intranet version should be used to verify.*



Distribution Operations

|                               |                      |   |
|-------------------------------|----------------------|---|
| Effective Date:<br>12/07/1993 | <b>Meter Records</b> | Standard Number:<br><b>GS 6400.070(CG)</b><br>P&P 724-7 |
| Supersedes:<br>N/A            |                      | Page 2 of 29  |

C 2385

COH

Buff with Black Ink

Instructions for completion of side one of the Meter Record Card by the person removing the meter are contained in Exhibit A. Special emphasis should be given to the accuracy of the meter removal code to assure appropriate repairs are made and statistical information on meter performance is appropriate.

**2.2 Meter Shop Use of the Meter Record Card**

The meter shop employee, before performing the in-test on the meter, shall verify the meter number and reading shown on the Meter Record Card. The verification shall be by a check mark on the Tag section. If a significant difference exists between the dial reading and the Meter Record Card recorded reading, the Meter Shop shall:

- a. notify the appropriate Area Office using Form C 2203, "Incorrect Meter Readings," (Exhibit C).
- b. insert the correct reading above the erroneous lined out reading on the Tag and Meter Record sections.

Side 2 of the Meter Record Card will be completed by the Meter Shop during processing.

Should an index be changed at the Meter Shop, the old reading on the Tag section will be lined out and the new index reading inserted above the old reading. The reading on Side 1 of the Meter Record section shall carry the reading of the old index removed from the meter. Following completion of the repair of the meter, the Meter Record section of the card will then be detached from the Tag section and forwarded to the Meter Shop Superintendent/Supervisor. The Tag section will remain on the meter.

Repaired meters will have the Tag section of the Meter Record Card affixed to the meter prior to release by the Meter Shop.

It is the responsibility of the Meter Shop Superintendent/Supervisor, to have a completed tag accompany each new meter shipped to an Area, if requested.

Should a location receive a meter from the Meter Shop with an improper color tag, the meter shall be accompanied by Form C 74, "Material Transfer," (Exhibit D). A notation should be placed on a foreign tag indicating the meter was accompanied by a Transfer.



Distribution Operations

|                               |                      |   |
|-------------------------------|----------------------|---|
| Effective Date:<br>12/07/1993 | <b>Meter Records</b> | Standard Number:<br><b>GS 6400.070(CG)</b><br>P&P 724-7 |
| Supersedes:<br>N/A            |                      | Page 3 of 29  |

**2.3 Report of Meters Requiring Fast Meter Adjustments**

On the last workday of each month, the Bethel Park, PA and Portsmouth, VA Meter Shop Superintendent/Supervisor will prepare Form C-1772, "Report of Meters Requiring Fast Meter Adjustments," (Exhibit E) using information provided in the Meter Record Section. The Columbus, OH Meter Shop will enter the necessary information in a CMS computer program. A report will be forwarded to the Area Offices for preparation of the necessary adjustments. For those offices without any fast meter adjustments, a report will be forwarded showing "None."

**2.4 Processing Meter Record Cards**

The Meter Record sections will be forwarded to the Meter Shop Superintendent/Supervisor for processing. After all data is entered into the computer, the Meter Record sections will be retained for two years by the Meter Shop.

**2.5 Area Office Use of Tag Section for Stock Control**

When a serviceman removes a meter from an "OK" meter storage shelf, verifies kind, size and reading, and places it on his/her service truck, he/she will insert the Service Truck Number and date on the Tag section attached to the meter in the space "Received By Truck No.", remove the Tag section from the meter and forward to the Service Supervisor or to a designated clerk. The Tag section will then become a part of a file called "Meters Issued to Servicemen." The Tag section will remain in this file until such time as the serviceman turns in a "set or "change order" for the meter. The Tag section will then be checked against the Meter Order for verification after which it will be attached to the Meter Order and forwarded to the Area Office.

Upon receipt of the Meter Order and Tag section, Office personnel will verify the data on the Meter Order and Tag section and execute the order.

In the event a serviceman should wish to return a meter to the "OK" meter shelf, it will be necessary to retrieve the Tag section from the "Meters Issued to Servicemen" file, reattach the Tag section to the meter, and remove the Service Truck Number before returning the meter to the shelf.

On a monthly basis the Service Supervisor or designee shall review all Tag sections in the "Meters Issued to Servicemen" file to determine the present location of the meters. If it is determined that the meter has not been set and all further investigations fail to reveal its location, such as remaining on a service truck, it must be presumed lost, in which case Form C-74, "Material Transfer," to remove meter from records will be





Distribution Operations

|                               |                      |   |
|-------------------------------|----------------------|---|
| Effective Date:<br>12/07/1993 | <b>Meter Records</b> | Standard Number:<br><b>GS 6400.070(CG)</b><br>P&P 724-7 |
| Supersedes:<br>N/A            |                      | Page 4 of 29  |

prepared (See Exhibit D).

**2.6 Preparation of Kentucky Public Service Commission Report**

**2.6.1 Low Pressure Meters Intested in the Meter Shop or Field Tested**

By the 15th day of the following month the Meter Shop will submit to CKY monthly such information pertaining to meter accuracy of all meters intested in the Meter Shop that is required for the preparation of the Kentucky Public Service Commission report (Exhibit F). Low pressure meters tested in the field will be reported to the Area and District Office by the Meter Inspector for incorporation into the report.

Upon receipt of this information, the District Office will complete the report and forward it to the Kentucky Public Service Commission. A copy of the District's report will be mailed to the Engineering, Measurement and Regulation Manager.

**2.6.2 Excess Pressure Meters Field Tested**

Meter Inspectors will report the number of excess pressure meters field tested during the month to the CKY District. The CKY District will fill out the form (Exhibit G) and send it to the Engineering, Measurement and Regulation Manager, by the fifth working day of the succeeding month, so that a report can be prepared and sent to the Public Service Commission of Kentucky not later than the twentieth day of the succeeding month.

**3. METER ACCOUNTING**

**3.1 Meter Purchases**

On receipt of any new meter by the Meter Shop, Form C 2068, "Notification of New Meter Purchases," (Exhibit H) shall be completed and distributed to the Managers of Engineering - Measurement and Regulation and Accounting, Tax and Risk Management - Asset Accounting.

**3.2 Material Transfers Used as Meter Transfers**

The "Material Transfer," either Form C-74 or C-74-1 (Exhibit D), will be used for recording meter movements. When a large quantity of different types of meters are transferred, use Form C-74-1. These transfers will carry a Meter Transfer (MT)



Distribution Operations

|                               |                      |   |
|-------------------------------|----------------------|---|
| Effective Date:<br>12/07/1993 | <b>Meter Records</b> | Standard Number:<br><b>GS 6400.070(CG)</b><br>P&P 724-7 |
| Supersedes:<br>N/A            |                      | Page 5 of 29  |

number which will be assigned by the Meter Shops.

A meter transfer will be required in those cases when the movement of the meter affects plant investments. These are: meters retired, meters sold, meters lost, meters found, meters transferred to or from excess pressure measuring stations (including Exchange Stations or Direct Purchase Stations), and meters transferred from one CDC Company to another (Exhibit D).

The Area Offices or Warehouses that issue meter transfers for any reason will contact the Meter Shop Superintendent/Supervisor to obtain an MT number. The Meter Shop Superintendent/Supervisor will be responsible for notifying Asset Accounting of meter transfers made during any fiscal month, starting on the 16th day of any month and ending on the 15th day of the following month. Notification will be by use of Form C 25, "Report of Transfers Held," (Exhibit I).

### 3.2.1 Junking Meters

When hardcase meters are junked in the Columbus and Portsmouth Meter Shops, the year each meter was purchased will be determined from the book entitled, "Serial Numbers of Displacement and Turbine Meters by Year of Manufacture," and entered on Form C-74-1, "Material Transfer." The transfers will indicate a movement from "Meter Investment" to the proper Stores Account at the appropriate location and will show an estimated value based on the total weight (Exhibit D).

The Pittsburgh Meter Shop will generate a computer report that is forwarded to Accounting, Tax and Risk Management - Asset Accounting monthly to transfer the meters to junk.

### 3.2.2 Material Transfer - Routing

- a. Junk Meters - The original and two copies of transfers will be required for junked meters and copies distributed as follows:
  - (1) White copy to Accounting, Tax and Risk Management - Asset Accounting.
  - (2) Pink copy to Purchasing Agent (also copy of Bill of Lading when transferring junked tin meters to Buyer).
  - (3) Blue copy to Meter Shop.



Distribution Operations

|                               |                      |   |
|-------------------------------|----------------------|---|
| Effective Date:<br>12/07/1993 | <b>Meter Records</b> | Standard Number:<br><b>GS 6400.070(CG)</b><br>P&P 724-7 |
| Supersedes:<br>N/A            |                      | Page 6 of 29  |

When only a few meters are junked, the year of meter purchase will be determined by Asset Accounting.

When a large number of meters are junked by the Meter Shop, one transfer will be made for the total number of meters junked and a Form C-74-1, "Material Transfer," will be prepared. The Meter Shop will complete the form listing the kind and size meter, code number, quantity, and year purchased. Asset Accounting will determine the unit price and total price for all meters listed on the Form C-74-1.

- b. All Other Meters - An original and three copies of the transfer will be required for all other movement of meters, and copies distributed as follows:
  - (1) White copy to Accounting, Tax and Risk Management - Asset Accounting.
  - (2) Pink copy to receiving location.
  - (3) Blue copy to Meter Shop.
  - (4) Buff copy to originator.

When a meter is lost or sold, the year the meter was purchased will be determined by Asset Accounting.

**3.2.3 Meters on Loan**

Form C-212, "Material Loaned Receipt," (Exhibit J) shall be prepared in duplicate for each meter to be loaned. The original copy is given to the customer, the duplicate filed by the local warehouse and accounted for as a meter in stock. The time limit on loaned meters will vary; however, loans for periods more than ninety (90) days should be infrequent and only to satisfy unusual circumstances.

**3.2.4 Annual Meter Inventory**

The inventory of all stock meters shall be taken on December 31, or the closest working day to it, and recorded on Form C-2003, "Meters In Stock (Supply and Budget Control)," Exhibit K for each Area Office. The inventory will show the total number of meters by make, size and meter code and the listing recorded in numerical sequence by meter code (Exhibit B).



**Gas Standard**

Distribution Operations

|                               |                      |   |
|-------------------------------|----------------------|---|
| Effective Date:<br>12/07/1993 | <b>Meter Records</b> | Standard Number:<br><b>GS 6400.070(CG)</b><br>P&P 724-7 |
| Supersedes:<br>N/A            |                      | Page 7 of 29  |

The Area Office meter inventories shall be sent to the District Operation Managers or equivalent and consolidated into a District Report. The sum of the meter totals of the Area Office meter inventories shall be checked to make certain that it is the same as the total figure on the District Report.

Two copies of each Area Office inventory summarized to a District level will be sent, no later than January 15, to the Manager, Measurement and Regulation, who will then forward one copy to Accounting, Tax and Risk Management - Asset Accounting.



Distribution Operations

|                               |                      |   |
|-------------------------------|----------------------|---|
| Effective Date:<br>12/07/1993 | <b>Meter Records</b> | Standard Number:<br><b>GS 6400.070(CG)</b><br>P&P 724-7 |
| Supersedes:<br>N/A            |                      | Page 8 of 29  |

**EXHIBIT A  
(1 of 2)**

**Instructions for the completion of the Meter Record Card**  
(See page 2 of this Exhibit.)

The following instructions are for the person removing the meter from the customer premise (side 1 of Meter Record Card).

| <u>Key</u> | <u>Item</u>        | <u>Description</u>   |
|------------|--------------------|--|
| 1          | Meter Number       | Insert "Meter Number" on both the Tag and Meter Record Sections (include all letter and numeric characters). The Meter Record Section block is completed by starting from the right side of the block. |
| 2          | Kind/Size          | Insert 3 digit code number from Exhibit B.   |
| 3          | Area Office        | Insert 4 digit Area Office Number  |
| 4          | Class              | Complete using one of the 1 digit codes indicated.   |
| 5          | Reason for Removal | Complete using one of the 1 digit codes indicated.   |
| 6          | Location           | Complete using one of the 1 digit codes indicated.   |
| 7          | PSID               | Enter PSID from DIS Order.   |
| 8          | Service Address    | Self-explanatory.  |
| 9          | Meter Removed By   | Self-explanatory.  |
| 10         | Date               | Enter date meter removed.  |
| 11         | Reading            | Enter meter reading on both Tag and Meter Record Sections. (Start from the right side on the Meter Record Section block.)  |
| 12         | Other              | If Code 00 is used in Key 4 above, insert comments as required.  |



Gas Standard

Distribution Operations

|                               |                        |   |
|-------------------------------|------------------------|---|
| Effective Date:<br>12/07/1993 | <h1>Meter Records</h1> | Standard Number:<br><b>GS 6400.070(CG)</b><br>P&P 724-7 |
| Supersedes:<br>N/A            |                        | Page 9 of 29  |

EXHIBIT A  
(2 of 2)

**Meter Record Card**

|                       |   |                     |                   |                    |                     |  |   |                                       |
|-----------------------|---|---------------------|-------------------|--------------------|---------------------|--|---|---------------------------------------|
| (SIDE 1)              | METER NO. (1)<br>KIND/SIZE (2)<br>RECEIVED BY TRUCK NO. (1)    DATE (2) * | <b>METER RECORD</b> | METER NUMBER* (1) | KIND/SIZE CODE (2) | AREA OFFICE NO. (3) | CLASS (4)<br>1-HEAT<br>2-NON-HEAT<br>3-EXCESS PRESSURE | REASON FOR REMOVAL (5)<br>1-DLE 8-DRP<br>2-PROGRAM 7-DPG<br>3-CAPACITY 8-INDEX GLASS<br>4-NOISY 9-DAMAGED<br>5-LEAK 0-OTHER (Explain below) | LOCATION (6)<br>1-INSIDE<br>2-OUTSIDE |
| PSID (7)              |   | SERVICE ADDRESS (8) |                   |                    |                     |  |   |                                       |
| METER REMOVED BY: (9) |   |                     |                   |                    | DATE (10)           | READING (11)   |   |                                       |
| OTHER (12)            |   |                     |                   |                    |                     |  |   |                                       |

\* Only the last 9 characters of the Meter Number will be entered into DIS

Tag Section

Meter Record Section

|   |   |  |   |  |
|---|---|--|---|--|
| COLUMBIA GAS DISTRIBUTION COMPANIES<br>COLUMBIA GAS OF KENTUCKY, INC.<br><small>FORM G-179-CPS (6-83)</small> | <b>CLASS OF REPAIR</b><br>1-TEST 8-DIAPHRAGM<br>2-ADJUST. 9-RETIRED<br>3-PARTIAL 7-NEW<br>4-GENERAL | <b>YEAR OF PUR.</b><br>(ENTER LAST TWO DIGITS) | <b>YR. LAST REPAIRED</b><br>(ENTER LAST TWO DIGITS) | <b>INTEST CONDITION</b><br>1-DOES NOT REGISTER<br>2-DOES NOT PASS GAS<br>3-NO TEST<br>4-LEAK<br>9-OK |
| INTEST ACCURACY %<br>CAPACITY    CHECK  | OUTTEST ACCURACY %<br>CAPACITY    CHECK   | INTEST METERMAN NUMBER                         |   | DATE<br>MO.    DAY    YR.  |
| OTHER DATA  |   | OUTTEST METERMAN NUMBER                        |   | DATE<br>MO.    DAY    YR.  |

\*See Section 2.5 of procedure.  
 Note: Side 2 of Meter Record Card is completed by Meter Shop Employees.  
 See Section 2.2 of procedure.



**Gas Standard**

Distribution Operations

|                               |                      |   |
|-------------------------------|----------------------|---|
| Effective Date:<br>12/07/1993 | <b>Meter Records</b> | Standard Number:<br><b>GS 6400.070(CG)</b><br>P&P 724-7 |
| Supersedes:<br>N/A            |                      | Page 10 of 29   |

**EXHIBIT B  
(1 of 5)**

TIN METERS  
KIND AND SIZE CODES  
 (Alphabetical Listing)

| <u>Size</u> *    | <u>Code</u> | <u>Size</u> *     | <u>Code</u> |
|------------------|-------------|-------------------|-------------|
| <u>American</u>  |             | <u>McDonald</u>   |             |
| 5                | 004         | 5                 | 304         |
| 10               | 012         | 10                | 308         |
| 11C              | 016         | 20                | 312         |
| 20M              | 020         | 30                | 316         |
| 20A              | 022         | 60                | 324         |
| 25C              | 024         |                   |             |
| 30               | 028         | <u>Metric</u>     |             |
| 40C              | 032         | 5                 | 338         |
| 60               | 040         | 10                | 342         |
| W-75             | 044         | 20                | 346         |
| W-210            | 045         | 30                | 354         |
| W-250            | 046         | 60                | 358         |
| W-300            | 047         |                   |             |
|                  |             | <u>Ohio</u>       |             |
|                  |             | 10                | 372         |
| <u>Cleveland</u> |             | <u>Pittsburgh</u> |             |
| 5                | 054         | 10                | 388         |
| 10               | 058         | 20                | 392         |
| 20               | 062         | 30                | 396         |
| 30               | 066         |                   |             |
| 45               | 070         | <u>Rock/Pitt</u>  |             |
| 60               | 074         | 5                 | 384         |
| 150              | 078         |                   |             |
| <u>Emco</u>      |             | <u>Standard</u>   |             |
| 10               | 100         | 5                 | 416         |
| <u>Griffin</u>   |             | <u>Superior</u>   |             |
| 5                | 122         | 5                 | 434         |
| 10               | 124         | 10                | 438         |
| 20               | 128         | 11C               | 442         |



**Gas Standard**

Distribution Operations

|                               |                      |   |
|-------------------------------|----------------------|---|
| Effective Date:<br>12/07/1993 | <b>Meter Records</b> | Standard Number:<br><b>GS 6400.070(CG)</b><br>P&P 724-7 |
| Supersedes:<br>N/A            |                      | Page 11 of 29   |

**EXHIBIT B  
(2 of 5)**

TIN METERS  
KIND AND SIZE CODES  
 (Alphabetical Listing)

| <u>Size</u> *    | <u>Code</u> | <u>Size</u> * | <u>Code</u> |
|------------------|-------------|---------------|-------------|
| <u>H &amp; M</u> |             |               |             |
| 5                | 178         | 20            | 446         |
| 10               | 186         | 25C           | 430         |
| 20               | 190         | 30            | 458         |
|                  |             | 40C           | 462         |
|                  |             | 60            | 466         |
| <u>Maryland</u>  |             |               |             |
| 5                | 250         |               |             |
| 10               | 258         |               |             |
| 20               | 270         |               |             |
| 30               | 278         |               |             |

\* Sizes shown will include suffix letters A, B and M.

HARDCASE METERS  
KIND AND SIZE CODES  
 (Alphabetical Listing)

| <u>Size</u>                | <u>Code</u> | <u>Size</u>                             | <u>Code</u> |
|----------------------------|-------------|---|-------------|
| <u>American (Aluminum)</u> |             | <u>American (Turbine) con't</u>         |             |
| 80B                        | 600         | 8GT-60M/125                             | 958         |
| AL175                      | 602         | 8GT-60M/300                             | 959         |
| AC175                      | 603         | 8GT-60M/720                             | 960         |
| 5B225                      | 604         | 8GT-60M/1440                            | 961         |
| AL250                      | 608         | 12GT-150M/175                           | 962         |
| 250B                       | 609         | <u>Emco or Rockwell (Iron or Steel)</u> |             |
| AL425                      | 616         | 0                                       | 772         |
| 500B                       | 610         | 1                                       | 776         |
| AL800                      | 612         | 2                                       | 780         |
| AL1000                     | 611         | 1600DU500                               | 782         |
| AL1400                     | 613         | 2-1/2                                   | 784         |
| AL2300                     | 617         | 3                                       | 788         |
| AL5000                     | 615         | 4                                       | 792         |
|                            |             | 4-1/2                                   | 796         |





Distribution Operations

|                               |                      |   |
|-------------------------------|----------------------|---|
| Effective Date:<br>12/07/1993 | <b>Meter Records</b> | Standard Number:<br><b>GS 6400.070(CG)</b><br>P&P 724-7 |
| Supersedes:<br>N/A            |                      | Page 12 of 29   |

**EXHIBIT B  
(3 of 5)**

**HARDCASE METERS  
KIND AND SIZE CODES  
(Alphabetical Listing)**

| <u>Size</u>                          | <u>Code</u> | <u>Size</u>                | <u>Code</u> |
|--------------------------------------|-------------|----------------------------|-------------|
| <u>American (Rotary, Aluminum)</u>   |             | 5                          | 800         |
| 3.5M, CVM125                         | 664         | <u>Ironcase (American)</u> |             |
| 5.3M, CVM125                         | 665         | A                          | 618         |
| 11M, CVM125                          | 667         | 5B                         | 622         |
| <u>American (Rotary, Production)</u> |             | 10B                        | 630         |
| CVMP 3.5M/125                        | 871         | 20B                        | 634         |
| CVMP 3.5M/300                        | 872         | 25B                        | 638         |
| CVMP 3.5M/575                        | 873         | 30B                        | 642         |
| CVMP 3.5M/720                        | 874         | 35B                        | 646         |
| CVMP 3.5M/1440                       | 875         | 60B                        | 650         |
| CVMP 5.3M/125                        | 876         | 80B                        | 654         |
| CVMP 5.3M/300                        | 877         | 250B                       | 658         |
| CVMP 5.3M/575                        | 878         | 500B                       | 662         |
| CVMP 5.3M/720                        | 879         | DU5000/350                 | 620         |
| CVMP 11M/125                         | 880         | <u>Ironclad</u>            |             |
| CVMP 11M/300                         | 881         | 1                          | 672         |
| CVMP 11M/575                         | 882         | 2                          | 676         |
| CVMP 11M/720                         | 883         | 3                          | 680         |
| CVMP 11M/1440                        | 884         | 4                          | 684         |
| <u>American (Turbine)</u>            |             | <u>Lancaster</u>           |             |
| 4GT-16M/125                          | 950         | 240/250                    | 870         |
| 4GT-16M/300                          | 951         | <u>National</u>            |             |
| 4GT-16M/720                          | 952         | 175A                       | 833         |
| 4GT-16M/1440                         | 953         | <u>Rockwell (Aluminum)</u> |             |
| 6GT-30M/125                          | 954         | 00/150                     | 768         |
| 6GT-30M/300                          | 955         | R-175                      | 814         |
| 6GT-30M/720                          | 956         | 175-S                      | 815         |
| 6GT-30M/1440                         | 957         | R-175/TC                   | 816         |
|                                      |             | R-200                      | 817         |



Distribution Operations

|                               |                      |   |
|-------------------------------|----------------------|---|
| Effective Date:<br>12/07/1993 | <b>Meter Records</b> | Standard Number:<br><b>GS 6400.070(CG)</b><br>P&P 724-7 |
| Supersedes:<br>N/A            |                      | Page 13 of 29   |

**EXHIBIT B  
(4 of 5)**

**HARDCASE METERS  
KIND AND SIZE CODES  
(Alphabetical Listing)**

| <u>Size</u>                      | <u>Code</u> | <u>Size</u>                     | <u>Code</u> |
|----------------------------------|-------------|---------------------------------|-------------|
| <u>Rockwell (Aluminum) con't</u> |             | <u>Roots/Conn/Dresser con't</u> |             |
| 250                              | 818         | 7M125/175                       | 707         |
| 310                              | 819         | 7M600                           | 716         |
| 415                              | 820         | 8X12                            | 699         |
| 750                              | 821         | 8X24                            | 700         |
| 800-1600                         | 822         | 10X15                           | 691         |
| 3000                             | 824         | 10X30                           | 701         |
| 4/5000/A5000                     | 826         | 10M/11M125/175                  | 709         |
| 10,000                           | 828         | 12X18                           | 702         |
|                                  |             | 12X36                           | 703         |
|                                  |             | 14X21                           | 714         |
| <u>Rockwell/Rotoseal</u>         |             | 14X42                           | 704         |
| R3/2A/2B                         | 803         | 16M125/175                      | 708         |
| R5                               | 805         | 16M400                          | 717         |
| R8                               | 804         | 8M400/16M600                    | 719         |
| R11                              | 806         | 19M400/38M600                   | 728         |
| RP3/125                          | 856         | 23M125                          | 712         |
| RP3/250                          | 857         | 11.5M400/23M600                 | 720         |
| RP3/575                          | 858         | 38M125                          | 711         |
| RP3/720                          | 859         | 56M125                          | 713         |
| RP3/1440                         | 860         | 102M125                         | 727         |
| RP5/125                          | 861         | 102M300                         | 721         |
| RP8/125                          | 862         | 3.6M600                         | 722         |
| RP11/125                         | 863         | 8C125                           | 723         |
|                                  |             | <u>Sprague</u>                  |             |
| <u>Rockwell Turbo</u>            |             | 1                               | 718         |
| T-18                             | 798         | 2                               | 726         |
| T-30                             | 827         | 3                               | 730         |
| T-60                             | 797         | 4A/675                          | 738         |
| T-140                            | 799         | 5A/1000, 5                      | 746         |
| TP-4/275                         | 850         | 175                             | 755         |
| TP-4/720                         | 851         | 175W/R                          | 756         |
| TP-4/1440                        | 852         | 175R/M                          | 757         |
| TP-9/275                         | 853         |                                 |             |
| TP-9/720                         | 854         |                                 |             |



**Gas Standard**

Distribution Operations

|                               |                      |   |
|-------------------------------|----------------------|---|
| Effective Date:<br>12/07/1993 | <b>Meter Records</b> | Standard Number:<br><b>GS 6400.070(CG)</b><br>P&P 724-7 |
| Supersedes:<br>N/A            |                      | Page 14 of 29   |

**EXHIBIT B  
(5 of 5)**

HARDCASE METERS  
KIND AND SIZE CODES  
(Alphabetical Listing)

| <u>Size</u>                  | <u>Code</u> | <u>Size</u>     | <u>Code</u> |
|------------------------------|-------------|-----------------|-------------|
| <u>Rockwell Turbo cont;d</u> |             |                 |             |
| TP-9/1440                    | 855         | 240             | 758         |
|                              |             | 240W/R          | 759         |
| <u>Roots/Conn/Dresser</u>    |             |                 |             |
| 1.5M125/175                  | 690         | 250             | 761         |
| 2M900                        | 710         | 250W/R          | 763         |
| 3M125/175                    | 705         | <u>Superior</u> |             |
| 3M1200                       | 729         | AL175A          | 829         |
| 3.5X10                       | 692         | AL250           | 830         |
| 4X8                          | 693         | AI340           | 831         |
| 4X12                         | 694         | <u>Tobey</u>    |             |
| 4.6M900/7M1200               | 715         | A/B             | 832         |
| 5X10                         | 695         | 1               | 836         |
| 5X15                         | 696         | 2               | 840         |
| 5M125/175                    | 706         | 4               | 848         |
| 6X10                         | 697         |                 |             |
| 6X18                         | 698         |                 |             |



Gas Standard

Distribution Operations

|                               |                        |   |
|-------------------------------|------------------------|---|
| Effective Date:<br>12/07/1993 | <h2>Meter Records</h2> | Standard Number:<br><b>GS 6400.070(CG)</b><br>P&P 724-7 |
| Supersedes:<br>N/A            |                        | Page 15 of 29   |

EXHIBIT C

| <b>COLUMBIA GAS</b><br>Distribution Companies   |             | INCORRECT METER READING |         |                      |                       |
|---|-------------|-------------------------|---------|----------------------|-----------------------|
| COMPANY<br><input type="checkbox"/> CKY <input type="checkbox"/> COH <input type="checkbox"/> CMD <input type="checkbox"/> CPA <input type="checkbox"/> COS |             | AREA OFFICE             | DATE    |                      |                       |
| METER NO.   | KIND & SIZE | PSID                    | ADDRESS | READING ON METER TAG | CORRECT INDEX READING |
|   |             |                         |         |                      |                       |
|   |             |                         |         |                      |                       |
|   |             |                         |         |                      |                       |
|   |             |                         |         |                      |                       |
|   |             |                         |         |                      |                       |
|   |             |                         |         |                      |                       |
|   |             |                         |         |                      |                       |
|   |             |                         |         |                      |                       |
|   |             |                         |         |                      |                       |
|   |             |                         |         |                      |                       |
|   |             |                         |         |                      |                       |
|   |             |                         |         |                      |                       |
|   |             |                         |         |                      |                       |
|   |             |                         |         |                      |                       |
|   |             |                         |         |                      |                       |
|   |             |                         |         |                      |                       |
|   |             |                         |         |                      |                       |
|   |             |                         |         |                      |                       |
|   |             |                         |         |                      |                       |
|   |             |                         |         |                      |                       |
|   |             |                         |         |                      |                       |
|   |             |                         |         |                      |                       |
|   |             |                         |         |                      |                       |

Meter Shop \_\_\_\_\_ Signed \_\_\_\_\_

COPIES: Original forwarded to Area Office.  
 Copy retained in Meter Shop File.  
 FORM C 2303 CPS (6-83)



Distribution Operations

|                               |                      |   |
|-------------------------------|----------------------|---|
| Effective Date:<br>12/07/1993 | <b>Meter Records</b> | Standard Number:<br><b>GS 6400.070(CG)</b><br>P&P 724-7 |
| Supersedes:<br>N/A            |                      | Page 16 of 29   |

**EXHIBIT D  
(1 of 7)**

To A Measuring Station

COLUMBIA GAS DISTRIBUTION COMPANIES  
**COH 34**

F Meter Investment  
 Columbus Ohio  
 O LOCATION \_\_\_\_\_ LOC NO \_\_\_\_\_ DATE \_\_\_\_\_  
 M \_\_\_\_\_

MATERIAL TRANSFER  
**Central 1300**

T Bordens Truck Mill  
 O MS #7-5409  
 O LOCATION \_\_\_\_\_ LOC NO \_\_\_\_\_

| TYPE | DESCRIPTION OF MATERIAL | QUANTITY | STOCK SYMBOL NUMBER | UNIT PRICE | AMOUNT |
|------|-------------------------|----------|---------------------|------------|--------|
| T18  | Turbine Serial 123456   | 1        |                     |            | ea.    |

| DEBIT | CREDIT | CO (2) | GEN (2) | AUX (4) | CE (4) | PROJ (3) | ACTV (3) | FAC (6) | MCC (4) | TCC (4) | LSB (2) | STOCKS OVER |
|-------|--------|--------|---------|---------|--------|----------|----------|---------|---------|---------|---------|-------------|
|       |        | 34     | 101     |         |        |          | 10010    | G38100  |         |         |         |             |
|       |        | 34     | 101     |         |        |          | 10010    | G38510  |         |         |         |             |

ISSUED BY \_\_\_\_\_ CHARGE ACCOUNT \_\_\_\_\_  
 DATE \_\_\_\_\_  
 TRANSFER NO \_\_\_\_\_

From A Measuring Station

COLUMBIA GAS DISTRIBUTION COMPANIES  
**COH**

F Ajax Shoe Co.  
 Columbus Ohio  
 O LOCATION \_\_\_\_\_ LOC NO \_\_\_\_\_ DATE \_\_\_\_\_  
 M \_\_\_\_\_

MATERIAL TRANSFER  
**Central 1300**

T Meter Investment  
 O Columbus Ohio  
 O LOCATION \_\_\_\_\_ LOC NO \_\_\_\_\_

| TYPE | DESCRIPTION OF MATERIAL | QUANTITY | STOCK SYMBOL NUMBER | UNIT PRICE | AMOUNT |
|------|-------------------------|----------|---------------------|------------|--------|
| T18  | Turbine Serial 123457   | 1        |                     |            | ea.    |

| DEBIT | CREDIT | CO (2) | GEN (2) | AUX (4) | CE (4) | PROJ (3) | ACTV (3) | FAC (6) | MCC (4) | TCC (4) | LSB (2) | STOCKS OVER |
|-------|--------|--------|---------|---------|--------|----------|----------|---------|---------|---------|---------|-------------|
|       |        | 34     | 101     |         |        |          | 10010    | G38500  |         |         |         |             |
|       |        | 34     | 101     |         |        |          | 10010    | G38510  |         |         |         |             |

ISSUED BY \_\_\_\_\_ CHARGE ACCOUNT \_\_\_\_\_  
 DATE \_\_\_\_\_  
 TRANSFER NO \_\_\_\_\_



**Gas Standard**

Distribution Operations

|                               |                      |   |
|-------------------------------|----------------------|---|
| Effective Date:<br>12/07/1993 | <b>Meter Records</b> | Standard Number:<br><b>GS 6400.070(CG)</b><br>P&P 724-7 |
| Supersedes:<br>N/A            |                      | Page 17 of 29   |

**EXHIBIT D  
(2 of 7)**

**Meter Sold**

COLUMBIA GAS DISTRIBUTION COMPANIES

ACCOUNT NO. COH 34 Sold

WORK ORDER NO. Meter Investment MATERIAL TRANSFER JB Jones Productions

FROM Columbus, Ohio Meter Shop TO Zanesville, Ohio

LOCATION 7300

---

| QTY    | DESCRIPTION OF MATERIAL              | QUANTITY | STOCK SYMBOL NUMBER | UNIT PRICE | TOTAL   | REMARKS |
|--------|--------------------------------------|----------|---------------------|------------|---------|---------|
| 10,000 | Rockwell Serial #V-1234<br>Year 1965 | 1        |                     | ea         | 1600 00 |         |

---

| DEBIT | CREDIT | CO (M) | GEN (S) | AUX (S) | CE (S) | PROJ (S) | ACTN (S) | FAC (S) | MCC (S) | TCC (S) | SEC (S) | STOCK COVER |
|-------|--------|--------|---------|---------|--------|----------|----------|---------|---------|---------|---------|-------------|
|       |        | 34     | 108     |         | 0058   |          | 00568    | 003810  |         | 10049   |         |             |
|       |        | 34     | 143     |         | 9900   |          |          | 100100  |         |         |         |             |

ISSUED BY: \_\_\_\_\_ CHARGE ACCOUNT: \_\_\_\_\_

MAILED BY: \_\_\_\_\_ DATE: \_\_\_\_\_

USED FOR: \_\_\_\_\_ TRANSFER NO: \_\_\_\_\_

**From CDC to TCO**

COLUMBIA GAS DISTRIBUTION COMPANIES

ACCOUNT NO. COH 34

WORK ORDER NO. Columbus Meter Shop MATERIAL TRANSFER Columbia Gas Transmission

FROM Columbus, Ohio 7750 TO Bangs Ohio

LOCATION 7750

---

| QTY | DESCRIPTION OF MATERIAL          | QUANTITY | STOCK SYMBOL NUMBER | UNIT PRICE | TOTAL | REMARKS |
|-----|----------------------------------|----------|---------------------|------------|-------|---------|
| 102 | Roots/Conn Meter<br>Serial #5678 | 1        |                     | ea         |       |         |

---

| DEBIT | CREDIT | CO (M) | GEN (S) | AUX (S) | CE (S) | PROJ (S) | ACTN (S) | FAC (S) | MCC (S) | TCC (S) | SEC (S) | STOCK COVER |
|-------|--------|--------|---------|---------|--------|----------|----------|---------|---------|---------|---------|-------------|
|       |        | 34     | 108     |         | 0058   |          | 00888    | 003810  |         | 0000    |         |             |
|       |        | 51     | 154     |         |        |          | 01025    |         |         |         |         |             |

ISSUED BY: \_\_\_\_\_ CHARGE ACCOUNT: \_\_\_\_\_

MAILED BY: \_\_\_\_\_ DATE: \_\_\_\_\_

USED FOR: \_\_\_\_\_ TRANSFER NO: \_\_\_\_\_

Contact TCC for this info.



**Gas Standard**

Distribution Operations

|                               |                        |   |
|-------------------------------|------------------------|---|
| Effective Date:<br>12/07/1993 | <h2>Meter Records</h2> | Standard Number:<br><b>GS 6400.070(CG)</b><br>P&P 724-7 |
| Supersedes:<br>N/A            |                        | Page 18 of 29   |

**EXHIBIT D  
(3 of 7)**

Tin Case Meters Junked

COLUMBIA GAS DISTRIBUTION COMPANIES  
COH 34

ACCOUNT OR METER OWNER NO. Meter Investment ACCOUNTS RECEIVABLE  
Columbus Meter Shop MATERIAL TRANSFER AMG Resources Corp.  
Columbus, Ohio 1300 011 Metallic Division  
NEWVILLE Island, Pa.

| SIZE | DESCRIPTION OF MATERIAL | QUANTITY | STOCK SYMBOL NUMBER | UNIT PRICE | PER | AMOUNT |
|------|-------------------------|----------|---------------------|------------|-----|--------|
|      |                         |          |                     |            |     |        |
|      |                         |          |                     |            |     |        |
|      |                         |          |                     |            |     |        |
|      |                         |          |                     |            |     |        |
|      |                         |          |                     |            |     |        |
|      |                         |          |                     |            |     |        |
|      |                         |          |                     |            |     |        |
|      |                         |          |                     |            |     |        |
|      |                         |          |                     |            |     |        |
|      |                         |          |                     |            |     |        |

| DEBIT  | CHARGE ACCOUNT | CO (2) | GEN (2) | AUX (4) | CE (4) | PROV (5) | ACTY (5) | PAC (6) | HCC (4) | CC (4) | LOC (2) | STOCKS OVER |
|--------|----------------|--------|---------|---------|--------|----------|----------|---------|---------|--------|---------|-------------|
| DEBIT  |                | 34     | 108     |         | 0058   |          | 00568    | WP3810  |         | 0049   |         |             |
| CREDIT |                | 34     | 143     | 9900    |        |          | 10870    | 100100  |         |        |         |             |

ISSUED BY: \_\_\_\_\_ CHARGE ACCOUNT: \_\_\_\_\_  
MTR REC'D BY: \_\_\_\_\_ DATE: \_\_\_\_\_  
USED FOR: \_\_\_\_\_ TRANSFER NO: \_\_\_\_\_

Junk Meter (yard)

COLUMBIA GAS DISTRIBUTION COMPANIES  
COH 34

ACCOUNT OR METER OWNER NO. Columbus Meter Shop ACCOUNTS RECEIVABLE  
Columbus, Ohio MATERIAL TRANSFER Junk Yard  
Columbus, Ohio 1300 011

| SIZE   | DESCRIPTION OF MATERIAL                         | QUANTITY | STOCK SYMBOL NUMBER | UNIT PRICE | PER | AMOUNT |
|--------|---|----------|---------------------|------------|-----|--------|
| 10,000 | Rockwell Serial #12345<br>year 1950<br>254 lbs. | 1        |                     |            | ea  |        |
|        |   |          |                     |            |     |        |
|        |   |          |                     |            |     |        |
|        |   |          |                     |            |     |        |
|        |   |          |                     |            |     |        |
|        |   |          |                     |            |     |        |
|        |   |          |                     |            |     |        |
|        |   |          |                     |            |     |        |
|        |   |          |                     |            |     |        |
|        |   |          |                     |            |     |        |

| DEBIT  | CHARGE ACCOUNT | CO (2) | GEN (2) | AUX (4) | CE (4) | PROV (5) | ACTY (5) | PAC (6) | HCC (4) | CC (4) | LOC (2) | STOCKS OVER |
|--------|----------------|--------|---------|---------|--------|----------|----------|---------|---------|--------|---------|-------------|
| DEBIT  |                | 34     | 108     |         | 0058   |          | 00568    | WP3810  |         | 0049   |         |             |
| CREDIT |                | 34     | 154     |         |        |          |          |         |         | 1300   |         |             |

ISSUED BY: \_\_\_\_\_ CHARGE ACCOUNT: \_\_\_\_\_  
MTR REC'D BY: \_\_\_\_\_ DATE: \_\_\_\_\_  
USED FOR: \_\_\_\_\_ TRANSFER NO: \_\_\_\_\_







**Gas Standard**

Distribution Operations

|                               |   |   |
|-------------------------------|---|---|
| Effective Date:<br>12/07/1993 | <h2 style="margin: 0;">Meter Records</h2> | Standard Number:<br><b>GS 6400.070(CG)</b><br>P&P 724-7 |
| Supersedes:<br>N/A            | Page 20 of 29                             |   |

**EXHIBIT D  
(5 of 7)**

**For Transfer of Meters Purchased in Prior Years  
To Another CDC Company**

COLUMBIA GAS DISTRIBUTION COMPANIES  
COH

FROM: Columbia Gas of Ohio  
 TO: Columbia Gas of Pa.  
 REASON: Meter Investment  
 MATERIAL TRANSFER 1300

LOCATION: \_\_\_\_\_ DATE: \_\_\_\_\_

| QTY | DESCRIPTION OF METER           | SERIAL | SIZE (IN) | TYPE | PRICE | PER |
|-----|--------------------------------|--------|-----------|------|-------|-----|
| 4   | Rockwell Turbine Serial 123567 |        |           |      |       | ea  |

| TRAN CODE | LOC | CO | GEN | AUX | CE | PRO | ACT   | PAC    | HCC | TCC  | LOS | STOR OVER |
|-----------|-----|----|-----|-----|----|-----|-------|--------|-----|------|-----|-----------|
| DEBIT     |     | 34 | 108 |     |    |     | 00999 | WP3810 |     | 1993 |     |           |
| CREDIT    |     | 37 | 107 |     |    |     | 00998 | WP3810 |     | 1993 |     |           |

ISSUED BY: \_\_\_\_\_ CHARGE ACCOUNT: \_\_\_\_\_  
 RECORDED BY: \_\_\_\_\_ DATE: \_\_\_\_\_  
 TRANSFER NO: \_\_\_\_\_

Current year

---

**For Transfer of Meters Purchased in the Same Year  
They Are Transferred To Another CDC Company**

COLUMBIA GAS DISTRIBUTION COMPANIES  
COH

FROM: Columbia Gas of Ohio  
 TO: Columbia Gas of Pa.  
 REASON: Meter Investment  
 MATERIAL TRANSFER 1300

LOCATION: \_\_\_\_\_ DATE: \_\_\_\_\_

| QTY | DESCRIPTION OF METER          | SERIAL | SIZE (IN) | TYPE | PRICE | PER |
|-----|-------------------------------|--------|-----------|------|-------|-----|
| 1   | Rockwell Turbine Serial 12345 |        |           |      |       | ea  |

| TRAN CODE | LOC | CO | GEN | AUX | CE | PRO  | ACT   | PAC    | HCC | TCC  | LOS | STOR OVER |
|-----------|-----|----|-----|-----|----|------|-------|--------|-----|------|-----|-----------|
| DEBIT     |     | 34 | 107 |     |    | 2020 | 00567 | WP0000 |     | 0049 |     |           |
| CREDIT    |     | 37 | 107 |     |    | 2020 | 00567 | WP0000 |     | 0049 |     |           |

ISSUED BY: \_\_\_\_\_ CHARGE ACCOUNT: \_\_\_\_\_  
 RECORDED BY: \_\_\_\_\_ DATE: \_\_\_\_\_  
 TRANSFER NO: \_\_\_\_\_



**Gas Standard**

**Distribution Operations**

|                               |                        |   |
|-------------------------------|------------------------|---|
| Effective Date:<br>12/07/1993 | <h1>Meter Records</h1> | Standard Number:<br><b>GS 6400.070(CG)</b><br>P&P 724-7 |
| Supersedes:<br>N/A            |                        | Page 21 of 29   |

**EXHIBIT D  
(6 of 7)**

**To Columbia Propane**

COLUMBIA GAS DISTRIBUTION COMPANIES  
COH 34

ACCOUNT OR WORK ORDER NO. Columbus Meter Shop MATERIAL TRANSFER TO Columbia Propane

R \_\_\_\_\_ DIST \_\_\_\_\_

O LOCATION \_\_\_\_\_ LOC NO \_\_\_\_\_ DATE \_\_\_\_\_ TRANSFER NO \_\_\_\_\_

| SIZE | DESCRIPTION OF MATERIAL              | QUANTITY | STOCK SYMBOL NUMBER | UNIT PRICE | PER | AMOUNT |
|------|--------------------------------------|----------|---------------------|------------|-----|--------|
| 250  | American Serial T123456<br>year 1993 | 1        |                     |            | ea  |        |

| DEBIT | CREDIT | CO (7) | GEN (3) | AUX (4) | CE (4) | PROJ (8) | ACTIV (5) | FAC (8) | HOC (4) | TCC (4) | LOC (2) | STOCK COVER |
|-------|--------|--------|---------|---------|--------|----------|-----------|---------|---------|---------|---------|-------------|
|       |        | 34     | 108     |         | 0055   |          | 00888     | WP0000  |         |         | 3810    |             |
|       |        | 16     | 107     |         | 2020   |          | 00713     | WP0071  |         |         | 9321    |             |

ISSUED BY \_\_\_\_\_ CHARGE ACCOUNT \_\_\_\_\_

MAT'L REC'D BY \_\_\_\_\_ DATE \_\_\_\_\_ TRANSFER NO \_\_\_\_\_

USED FOR \_\_\_\_\_

**From Columbia Propane**

COLUMBIA GAS DISTRIBUTION COMPANIES

ACCOUNT OR WORK ORDER NO. Columbia Propane MATERIAL TRANSFER TO Columbus Meter Shop

R \_\_\_\_\_ DIST \_\_\_\_\_

O LOCATION \_\_\_\_\_ LOC NO \_\_\_\_\_ DATE \_\_\_\_\_ TRANSFER NO \_\_\_\_\_

| SIZE | DESCRIPTION OF MATERIAL               | QUANTITY | STOCK SYMBOL NUMBER | UNIT PRICE | PER | AMOUNT |
|------|---------------------------------------|----------|---------------------|------------|-----|--------|
| 250  | American Serial #T123456<br>year 1993 | 1        |                     |            | ea  |        |

| DEBIT | CREDIT | CO (7) | GEN (3) | AUX (4) | CE (4) | PROJ (8) | ACTIV (5) | FAC (8) | HOC (4) | TCC (4) | LOC (2) | STOCK COVER |
|-------|--------|--------|---------|---------|--------|----------|-----------|---------|---------|---------|---------|-------------|
|       |        | 16     | 108     |         | 0055   |          | 00714     | WP0822  |         |         | 9321    |             |
|       |        | 34     | 107     |         | 2020   |          | 00889     | WP3810  |         |         | 0000    |             |

ISSUED BY \_\_\_\_\_ CHARGE ACCOUNT \_\_\_\_\_

MAT'L REC'D BY \_\_\_\_\_ DATE \_\_\_\_\_ TRANSFER NO \_\_\_\_\_

USED FOR \_\_\_\_\_







Gas Standard

Distribution Operations

|                               |                      |   |
|-------------------------------|----------------------|---|
| Effective Date:<br>12/07/1993 | <b>Meter Records</b> | Standard Number:<br><b>GS 6400.070(CG)</b><br>P&P 724-7 |
| Supersedes:<br>N/A            |                      | Page 24 of 29   |

EXHIBIT F

Form 66 (4-1-68) REPORT OF METERS, CONSUMERS AND REFUNDS  
3-70 TO KENTUCKY PUBLIC SERVICE COMMISSION  
FRANKFORT, KENTUCKY  
TYPE OF METERS COVERED BY THIS REPORT GAS  
THIS REPORT TO BE MADE MONTHLY

Name of Utility Columbia Gas of Ky., Inc. Address 166 Walnut St., Lexington, Ky. 40507  
Ashland, Lynchiana, Frankfort, Georgetown, Irvine, Lexington,  
Towns Covered by this Report Mt. Sterling, Winchester, Mayaville, Paris

Period Covered by this Report January 1, 1982 to January 31, 1982

|                                     | Metered        | Unmetered     | Total          |
|-------------------------------------|----------------|---------------|----------------|
| Number Residential Customers Served | <u>102,925</u> | <u>      </u> | <u>102,925</u> |
| Number Commercial Customers Served  | <u>10,913</u>  | <u>      </u> | <u>10,913</u>  |
| Number Industrial Customers Served  | <u>94</u>      | <u>      </u> | <u>94</u>      |
| Number Other Customers Served       | <u>7</u>       | <u>      </u> | <u>7</u>       |
| Total Number - All Classes          | <u>113,939</u> | <u>      </u> | <u>113,939</u> |


| Meters from Service Percent of Accuracy | SLOW |   |   |           |          |          |          |          |        |        | FAST     |          |          |          |           |   | Total |
|---|------|---|---|-----------|----------|----------|----------|----------|--------|--------|----------|----------|----------|----------|-----------|---|-------|
|   | D.R. | + | + | 5.1 to 10 | 4.1 to 5 | 3.1 to 4 | 2.1 to 3 | 1.1 to 2 | 0 to 1 | 0 to 1 | 1.1 to 2 | 2.1 to 3 | 3.1 to 4 | 4.1 to 5 | 5.1 to 10 | + |       |
| <u>Yrs. Since Last Test</u>             |      |   |   |           |          |          |          |          |        |        |          |          |          |          |           |   |       |
| <u>Less Than 2 Years</u>                |      |   |   |           |          | 2        |          | 1        | 19     | 26     |          | 2        |          |          |           |   | 50    |
| <u>2 to 4 Years</u>                     |      |   |   |           |          |          | 3        | 5        | 91     | 5      | 2        |          |          |          |           |   | 106   |
| <u>4 to 6 Years</u>                     |      |   |   |           |          | 1        |          | 2        | 6      | 4      | 1        |          |          |          |           |   | 14    |
| <u>6 to 8 Years</u>                     |      |   |   |           |          |          |          | 1        | 3      | 2      |          |          |          |          |           |   | 6     |
| <u>8 to 10 Years</u>                    |      |   | 2 |           |          |          | 2        | 1        | 9      | 12     | 10       |          |          |          | 1         | 1 | 39    |
| <u>Over 10 Years</u>                    |      |   | 5 | 1         |          | 1        | 2        | 2        | 56     | 84     | 10       | 3        | 1        |          |           |   | 165   |
| <u>Time Unknown</u>                     |      |   |   |           |          |          |          |          |        |        |          |          |          |          |           |   |       |
| <u>TOTAL</u>                            |      | 8 |   | 2         |          | 7        | 4        | 12       | 101    | 133    | 23       | 5        | 1        | 1        | 1         |   | 298   |


(\*Do not register)

New Meters tested this period 80 Total Meters tested this period 378  
Include D.R. Meters.

| Condition of Meters | Number     | %           |
|---------------------|------------|-------------|
| More than 1% Fast   | <u>8</u>   | <u>2.7</u>  |
| More than 1% Slow   | <u>13</u>  | <u>4.5</u>  |
| Within Limits       | <u>269</u> | <u>92.8</u> |

Number of Tests Made at Customers' Request During Period 4  
Number of Tests Made at Commission's Request During Period NONE  
Number of Meters on Which Refunds Were Made During Period 4  
Total Amount of Refunds Made During Period \$93.25  
Number of Customers Billed for Slow Meters During Period NONE  
Total Amount Billed on Slow Meters During Period NONE

Report Covering Meter Tests Approved by:   
Title District Service Manager

Reports Covering Customers and Refunds Approved by:   
Title District Office Manager



Distribution Operations

|                               |                        |   |
|-------------------------------|------------------------|---|
| Effective Date:<br>12/07/1993 | <h2>Meter Records</h2> | Standard Number:<br><b>GS 6400.070(CG)</b><br>P&P 724-7 |
| Supersedes:<br>N/A            |                        | Page 25 of 29   |

EXHIBIT G

GAS UTILITY REPORT OF METERS TESTED  
TO  
THE PUBLIC SERVICE COMMISSION OF KENTUCKY  
FRANKFORT, KENTUCKY

Name of Utility Columbia Gas of Kentucky, Inc. Operating District ALL  
 Period Covered By This Report October 1, 1981 to October 31, 1981  
 Number of Orifice Gauges Tested 0 Orifice Plates Checked 0 Specific Gravities 0  
 Number of Displacement Meters Tested This Period:  
 Over 2X Slow 4; Over 2X Fast 2; Did Not Register 0; Zero to 2X Slow 0;  
 Zero to 2X Fast 0; Correct 9; Total 15

SUMMARY OF METERS FOR PERIOD COVERED BY THIS REPORT

| Types of Meters                                   | No. of Meters in Service |         | No. of Meters in Service Tested |         |
|---|--------------------------|---------|---------------------------------|---------|
|   | Displacement             | Orifice | Displacement                    | Orifice |
| Foreign Owned Meters                              | 0                        | 0       | 0                               | 0       |
| Purchase and Royalty Meters                       | 0                        | 0       | 0                               | 0       |
| Company Meters (Fuel, Town Border<br>Check, etc.) | 5                        | 0       | 0                               | 0       |
| <u>Sales Meters</u>                               |                          |         |                                 |         |
| Commercial  | 154                      | 0       | 5                               | 0       |
| Industrial  | 107                      | 0       | 10                              | 0       |
| Wholesale   | 4                        | 0       | 0                               | 0       |
| TOTAL METERS                                      | 270                      | 0       | 15                              | 0       |

Fast Due for Test: Orifice 0 Orifice Plates 0 Displacement Meters 0  
 Number of Tests Made at Customer's Request as per this Report 0  
 Number of Tests Made at Commission's Request as per this Report 0  
 Number of Refunds Due to Fast Meters This Period 0  
 Total Amount of Refund Due to Fast Meters Bills adjusted during current month.  
 Number of Refunds Due to Slow Meters This Period 0  
 Total Amount of Refund Due to Slow Meters Bills adjusted during current month.  
 Approved By [Signature] Title Manager, Measurement and Regulation

NOTE: This report is prepared by the Gas Measurement Department and pertains only to meters which measure gas at pressures in excess of normal distribution line pressures. Any report on Domestic and Low Pressure Meters will be made by the Distribution Department.




**Gas Standard**

Distribution Operations

|                               |                      |   |
|-------------------------------|----------------------|---|
| Effective Date:<br>12/07/1993 | <b>Meter Records</b> | Standard Number:<br><b>GS 6400.070(CG)</b><br>P&P 724-7 |
| Supersedes:<br>N/A            |                      | Page 26 of 29   |

**EXHIBIT H**

**NOTIFICATION OF NEW METER PURCHASES**



**COLUMBIA GAS**  
Distribution Companies

COMPANY:

 CKY     CMD     COH     CPA     COS  

MANUFACTURER:

 AMERICAN     DRESSER     EQUIMETER     SCHLUMBERGER     ROMET     OTHER

|                        |                |                              |
|------------------------|----------------|------------------------------|
| PURCHASE ORDER NUMBER: | DELIVERY DATE: |                              |
| QUANTITY               | KIND & SIZE    | MANUFACTURER'S SERIAL NUMBER |
|                        |                |                              |
|                        |                |                              |
|                        |                |                              |
|                        |                |                              |
|                        |                |                              |
|                        |                |                              |
|                        |                |                              |
|                        |                |                              |

COMPILED BY:  
FORM C-2083 CPS  
03/92



Distribution Operations

|                               |                        |   |
|-------------------------------|------------------------|---|
| Effective Date:<br>12/07/1993 | <h1>Meter Records</h1> | Standard Number:<br><b>GS 6400.070(CG)</b><br>P&P 724-7 |
| Supersedes:<br>N/A            |                        | Page 27 of 29   |

EXHIBIT I

**COLUMBIA GAS DISTRIBUTION COMPANIES**

METER TRANSFERS     VOUCHER NO. \_\_\_\_\_  
 MATERIAL TRANSFERS     FORM NO. \_\_\_\_\_  
 MERCHANDISE TRANSFERS

REPORT OF \_\_\_\_\_

(COMPANY) \_\_\_\_\_ DISTRICT \_\_\_\_\_

ISSUED DURING MONTH ENDED \_\_\_\_\_ 19\_\_\_\_ NOS. \_\_\_\_\_ TO \_\_\_\_\_

NOS. ASSIGNED NOT USED: WRITTEN HELD DISTRICT OFFICE: OUTSTANDING GENERAL OFFICE:

| NUMBER | NUMBER | NUMBER | NUMBER | NUMBER | NUMBER | NUMBER | NUMBER | NUMBER | NUMBER | NUMBER | NUMBER |
|--------|--------|--------|--------|--------|--------|--------|--------|--------|--------|--------|--------|
|        |        |        |        |        |        |        |        |        |        |        |        |
|        |        |        |        |        |        |        |        |        |        |        |        |
|        |        |        |        |        |        |        |        |        |        |        |        |
|        |        |        |        |        |        |        |        |        |        |        |        |
|        |        |        |        |        |        |        |        |        |        |        |        |
|        |        |        |        |        |        |        |        |        |        |        |        |
|        |        |        |        |        |        |        |        |        |        |        |        |
|        |        |        |        |        |        |        |        |        |        |        |        |
|        |        |        |        |        |        |        |        |        |        |        |        |
|        |        |        |        |        |        |        |        |        |        |        |        |
|        |        |        |        |        |        |        |        |        |        |        |        |
|        |        |        |        |        |        |        |        |        |        |        |        |
|        |        |        |        |        |        |        |        |        |        |        |        |
|        |        |        |        |        |        |        |        |        |        |        |        |
|        |        |        |        |        |        |        |        |        |        |        |        |
|        |        |        |        |        |        |        |        |        |        |        |        |
|        |        |        |        |        |        |        |        |        |        |        |        |
|        |        |        |        |        |        |        |        |        |        |        |        |
|        |        |        |        |        |        |        |        |        |        |        |        |
|        |        |        |        |        |        |        |        |        |        |        |        |
|        |        |        |        |        |        |        |        |        |        |        |        |
|        |        |        |        |        |        |        |        |        |        |        |        |
|        |        |        |        |        |        |        |        |        |        |        |        |
|        |        |        |        |        |        |        |        |        |        |        |        |
|        |        |        |        |        |        |        |        |        |        |        |        |

\_\_\_\_\_ SIGNED \_\_\_\_\_ DISTRICT STORE KEEPER  
 \_\_\_\_\_ 19\_\_\_\_  
 SENT TO GENERAL OFFICE \_\_\_\_\_  
 MUST BE SENT IN WITH FINAL TRANSFER





### Gas Standard

Distribution Operations

|                               |                        |   |
|-------------------------------|------------------------|---|
| Effective Date:<br>12/07/1993 | <h2>Meter Records</h2> | Standard Number:<br><b>GS 6400.070(CG)</b><br>P&P 724-7 |
| Supersedes:<br>N/A            |                        | Page 28 of 29   |

### EXHIBIT J

FORM C-212 CSD  
(8-83)

COLUMBIA GAS DISTRIBUTION COMPANIES  
**MATERIAL LOANED RECEIPT**

| QUANTITY | SIZE | DESCRIPTION |
|----------|------|-------------|
|          |      |             |
|          |      |             |
|          |      |             |
|          |      |             |
|          |      |             |
|          |      |             |
|          |      |             |
|          |      |             |
|          |      |             |
|          |      |             |
|          |      |             |
|          |      |             |
|          |      |             |
|          |      |             |
|          |      |             |
|          |      |             |
|          |      |             |
|          |      |             |
|          |      |             |
|          |      |             |
|          |      |             |
|          |      |             |

WE HAVE RECEIVED THE ABOVE MATERIAL FROM THE \_\_\_\_\_ WAREHOUSE OF COLUMBIA GAS OF \_\_\_\_\_, INC.  
AND AGREE TO RETURN IT IN GOOD CONDITION WITHIN \_\_\_\_\_ DAYS. WE ALSO AGREE TO PAY FOR ALL DAMAGES OCCURRING TO THE ABOVE MATERIAL WHILE  
IT IS IN OUR POSSESSION.

LOAN APPROVED BY \_\_\_\_\_ DISTRICT \_\_\_\_\_ NO. \_\_\_\_\_ SIGNED BY \_\_\_\_\_ TITLE \_\_\_\_\_  
DIST. MGR. (CDD/DV. Supt. (TCO) \_\_\_\_\_ COMPANY \_\_\_\_\_





Distribution Operations

|                               |   |   |
|-------------------------------|---|---|
| Effective Date:<br>01/01/1987 | <b>Accounting for Meter and Regulator Installations for Customer Accounting Billing</b> | Standard Number:<br><b>GS 6400.080(CG)</b><br>P&P 724-8 |
| Supersedes:<br>N/A            |   | Page 1 of 6   |

Companies Affected:

|                                     |   |   |
|-------------------------------------|---|---|
| <input type="checkbox"/> NIPSCO     | <input checked="" type="checkbox"/> CGV | <input checked="" type="checkbox"/> CMD |
| <input type="checkbox"/> NIFL       | <input checked="" type="checkbox"/> CKY | <input checked="" type="checkbox"/> COH |
| <input type="checkbox"/> Kokomo Gas | <input type="checkbox"/> CMA            | <input checked="" type="checkbox"/> CPA |

**REFERENCE**    None

**1. GENERAL**

Charges and credits for materials, labor and expenses incurred in connection with C.A.B. meter and regulator installations, replacements and retirements are to be made to the appropriate permanent Blanket Work Orders.

When replacing a meter or regulator and there is not a major change in the setting, the charges and credits are to be made to the appropriate operating or maintenance expense account.

A “New Regulator-Conversion” is a new regulator installation installed for an existing customer being served from a main being updated.

**2. METER SETTING INSTALLATIONS**

**2.1 Blanket Budget and Work Order Numbers**

- a. Blanket Budget No. 569 for new installations, 579 for replacements and 580 for removals or abandonment’s will normally cover all work in connection with Fixed Capital entries for C.A.B. customer meter setting installations
- b. Permanent Blanket Work Order Numbers have been assigned to each meter installation category under Blanket Budget Numbers 569, 579 and 580. Since these Work Order numbers are assigned on a permanent basis, it will not be necessary to issue annual Blanket Work Orders.
- c. Individual Districts and area locations shall be identified by the use of a three digit work order location number. This number is the same as the last three digits of the applicable Field Operations Location Number.
- d. When a meter setting with under 2 inch connections is replaced with a meter setting with 2 inch or over connections, the removal is to be reported under the

*This document is considered CONTROLLED only when viewed electronically on the Company's intranet. Printed or other electronic copies may not be current, and the intranet version should be used to verify.*



Distribution Operations

|                               |   |   |
|-------------------------------|---|---|
| Effective Date:<br>01/01/1987 | <b>Accounting for Meter and<br/>Regulator Installations for<br/>Customer Accounting Billing</b> | Standard Number:<br><b>GS 6400.080(CG)</b><br>P&P 724-8 |
| Supersedes:<br>N/A            |   | Page 2 of 6   |

580 Blanket Work Order to cover that size retirement. The 2 inch or over setting is to be shown as a new meter installation and charged to the Blanket Work Order 569 for 2 inch or over connections.

**2.2 Meter Settings and Installation Costs**

At the time of installation the meter setting and the related installation costs are to be charged as follows:

- a. Meter settings without regulators and installation costs
  - 1) New -
    - Under 2 inch meter connections - 107-569-Loc. - W.O. 61
    - 2 inch & over meter connections - 107-569-Loc. - W.O. 62
  - 2) Replacement - Charge Account
    - Under 2 inch meter connections - 107-579-Loc. - W.O. 65
    - 2 inch & over meter connections - 107-579-Loc. - W.O. 66
- b. Meter settings with regulators and installation costs
  - 1) Cost of setting
    - (a) New -
      - Meter Setting - Under 2 inch meter connections  
107-569-Loc. - W.O. 61
      - Meter Setting – 2 inch & over meter connections  
107-569-Loc. - W.O. 62
      - Regulator - Under 2 inch by Company & Plumber  
107-571-Loc. - W.O. 81
      - Regulator - Under 2 inch Conversions by Company & Contractor  
107-571-Loc. - W.O. 82



Distribution Operations

|                               |   |   |
|-------------------------------|---|---|
| Effective Date:<br>01/01/1987 | <b>Accounting for Meter and<br/>Regulator Installations for<br/>Customer Accounting Billing</b> | Standard Number:<br><b>GS 6400.080(CG)</b><br>P&P 724-8 |
| Supersedes:<br>N/A            |   | Page 3 of 6   |

Regulator – 2 inch only by Company & Plumber  
107-593-Loc. - W.O. 83

(b) Replacement -

Meter Setting - Under 2 inch meter connections  
107-579-Loc. - W.O. 65

Meter Setting – 2 inch & over meter connections  
107-579-Loc. - W.O. 66

Regulator - Under 2 inch by Company & Plumber  
107-581-Loc. - W.O. 85

Regulator - Under 2 inch by Contractor  
107-581-Loc. - W.O. 86

Regulator – 2 inch only by Company & Plumber  
107-597-Loc. - W.O. 87

(c) Retirement -

Meter Setting - Under 2 inch meter connections  
108-580-Loc. - W.O. 71

Meter Setting – 2 inch & over meter connections  
108-580-Loc. - W.O. 72

Regulator - Under 2 inch by Company & Plumber  
108-582-Loc. - W.O. 91

Regulator – 2 inch only by Company & Plumber  
108-598-Loc. - W.O. 92

2) Installation Costs

(a) New -

50% to 107-569-Loc. - W.O. 61 or W.O. 62

50% to 107-571-Loc. - W.O. 81 or W.O. 82 OR



Distribution Operations

|                               |   |   |
|-------------------------------|---|---|
| Effective Date:<br>01/01/1987 | <b>Accounting for Meter and<br/>Regulator Installations for<br/>Customer Accounting Billing</b> | Standard Number:<br><b>GS 6400.080(CG)</b><br>P&P 724-8 |
| Supersedes:<br>N/A            |   | Page 4 of 6   |

- 107-593-Loc. - W.O. 83
- (b) Replacement -
  - 50% to 107-579-Loc. - W.O. 65 or W.O. 66
  - 50% to 107-581-Loc. - W.O. 85 or W.O. 86 OR
  - 107-597-Loc. - W.O. 87

**3. SERVICE REGULATOR INSTALLATIONS**

**3.1 Blanket Budgets and Work Orders**

- a. House Regulator Blanket Budgets No. 571 and 593 for new installations, 581 and 579 for replacements, and 582 and 598 for retirements will normally cover all work in connection with fixed capital entries for regulator installations.
- b. Permanent Blanket Work Order Numbers have been assigned to each regulator installation, replacement, or retirement category under the appropriate Blanket Budgets. Since the numbers are assigned on a permanent basis, it will not be necessary to issue annual Blanket Work Orders.
- c. Individual Districts and area locations shall be identified by use of a three digit work location number. This number is the same as the last three digits of the applicable Field Operations Location Number.

**3.2 Regulator and Installation Costs**

- a. Service Regulators will be charged to account 154, Plant Materials and Operating Supplies, at the time of purchase. The regulator and installation costs are to be charged or credited to the appropriate Permanent Blanket Work Order at the time the regulator is installed, replaced or retired.
- b. Service regulator(s) and regulator installation(s) cost, when installed at a location other than at the meter location, shall be charged as follows:
  - 1. New -
    - Under 2 inch by Company & Plumber - 107-571-Loc. - W.O. 81
    - Under 2 inch Conversions by Company & Contractor -107-571-Loc. - W.O. 82
    - 2 inch only by Company & Plumber - 107-593-Loc. - W.O. 83



Distribution Operations

|                               |  |   |
|-------------------------------|--|---|
| Effective Date:<br>01/01/1987 | <h2 style="margin: 0;">Accounting for Meter and Regulator Installations for Customer Accounting Billing</h2> | Standard Number:<br><b>GS 6400.080(CG)</b><br>P&P 724-8 |
| Supersedes:<br>N/A            |  | Page 5 of 6   |

- 2. Replacement -
  - Under 2 inch by Company & Plumber - 107-581-Loc. - W.O. 85
  - Under 2 inch by Contractor - 107-581-Loc. - W.O. 86
  - 2 inch only by Company & Plumber - 107-597-Loc. - W.O. 87
- 3. Retirement -
  - Under 2 inch by Company & Plumber - 108-582-Loc. - W.O. 91
  - 2 inch only by Company & Plumber - 108-598-Loc. - W.O. 92
- c. When replacing a regulator with connections 2 inch and under, and there is a major change in the setting, a difference in size or a considerable variation in cost, all charges and credits are to be made to the appropriate blanket work order(s).
- d. Low pressure regulators with connections 3 inch and over will require specific construction and retirement work orders to be issued for new or replaced installations. Budget Number 593-Loc.-specific W.O. number will be issued for new, Budget 597-Loc.-specific work order for replacements, Budget 598-Loc.-work order for retirements.
- e. When a 2 inch low pressure regulator which is regulating gas to a meter at normal distribution pressure or at a fixed pressure, is replaced by a 2 inch or larger regulator which will regulate gas above normal distribution pressure (G.M.B. accounts) all charges and credits for retirement are to be made to the appropriate blanket work order and a specific work order 107-587-Loc.-W.O. number is to be issued to record the charges and credits for the replacements.

**3.3 Material Transfers**

- a. Material Transfers, Form C-74 or C-74-1, are to be issued for meter installations and for service regulators and installations at the time they are installed or removed.
- b. Although it is required that material transfers be pre-pared at the time of material issue, it is not intended that each transfer be numbered and submitted to the General Office. The individual transfers should be summarized for each work order. Accordingly, only the summary transfers would be numbered and submitted to the General Office. Copies of the individual transfers together with a copy of the numbered summary transfers should be filed in the Local and



Distribution Operations

|                               |   |   |
|-------------------------------|---|---|
| Effective Date:<br>01/01/1987 | <b>Accounting for Meter and<br/>Regulator Installations for<br/>Customer Accounting Billing</b> | Standard Number:<br><b>GS 6400.080(CG)</b><br>P&P 724-8 |
| Supersedes:<br>N/A            |   | Page 6 of 6   |

District or Division files to substantiate the completion reports for the blanket and specific work orders.

**3.4 Blanket Work Order Completion Report**

- a. A Blanket Work Order Completion Report, Form C-447-1, (Exhibit A), is to be prepared monthly for each area. All installations, replacements, and retirements or abandonment's are to be reported on the completion report by Taxing District number. The Completion Report should cover the same period as the material transfers issued for the current month.
- b. In compiling the Completion Report, the installations, replacements and retirements are to be listed from the material transfers processed for the corresponding period.
- c. It is important that the installations, replacements and retirements be reported accurately on the Blanket Work Order Completion Reports, as they are the basis for recording installations in Fixed Capital.
- d. House Regulators and installations handled through individual work orders are not to be listed on the Blanket Work Order Completion Report, but are to be reported on individual completion reports.
- e. The Blanket Work Order Completion Reports are to be submitted no later than the third working day of the following month to the Plant Accounting Section of the Finance Department.

**3.5 Regulator Record Card**

A House Regulator Card, Form C-316 (Exhibit B), is to be pre-pared for each company-owned house regulator at the time of installation showing kind, size, date installed and taxing district. These cards are to be filed in the local office in an active file and maintained on an up-to-date basis. These cards will be the detail for house regulators and installations and will be the only basis for allocating costs to each taxing district. Cards for regulators which are removed or retired should be removed from the file and disposed of in accordance with the Destruction of Records Schedule.

New York will use regulator card, Form C-316-1 (Exhibit B) that has additional information printed on the reverse side of the card for conformance to New York commission requirements.





Distribution Operations

|                               |  |   |
|-------------------------------|--|---|
| Effective Date:<br>10/01/2004 | <b>Fixed Pressure Factor Metering<br/>(FPFM)</b> | Standard Number:<br><b>GS 6400.090(CG)</b><br>P&P 724-9 |
| Supersedes:<br>N/A            |  | Page 1 of 4   |

Companies Affected:

|                                     |   |   |
|-------------------------------------|---|---|
| <input type="checkbox"/> NIPSCO     | <input checked="" type="checkbox"/> CGV | <input checked="" type="checkbox"/> CMD |
| <input type="checkbox"/> NIFL       | <input checked="" type="checkbox"/> CKY | <input checked="" type="checkbox"/> COH |
| <input type="checkbox"/> Kokomo Gas | <input type="checkbox"/> CMA            | <input checked="" type="checkbox"/> CPA |

**REFERENCE** Pennsylvania Code, Chapter 59.15.  
 Columbia Gas System Manual of Approved Procedures for Operations,  
 Supplement No. 26, "Gas Measurement-Standards and Calculations"

**1. GENERAL REQUIREMENTS**

Fixed Pressure Factor Metering (FPFM) is a method of measuring gas at elevated pressures using only conventional type meter indexes and temperature compensated meters. In FPFM, a pressure multiplier, developed by using the Boyle's Law equation, is applied by either computer or instrument to correct the meter dial registration to base pressure conditions.

FPFM eliminates the need for installing electrical or mechanical instruments used to correct for pressure and temperature. Therefore, measurement accuracy is dependent on the ability of the upstream regulation to maintain a constant specified delivery pressure to the meter.

Due to the economies that can be realized through FPFM as compared to installing a Gas Measurement Billing (GMB) station, its use is preferred given appropriate design conditions.

**2. METHODS OF FIXED PRESSURE FACTOR METERING (FPFM)**

The two methods of accomplishing FPFM are by:

- a. Fixed Pressure Compensation by Computer (FPCC), and
- b. Fixed Pressure Compensating Index (FPCI).

**2.1 Fixed Pressure Compensation by Computer (FPCC)**

FPCC is a method whereby the delivery pressure to a customer may be one-half pound (14" w.c.) or one to twenty psig, in one-psi increments (i.e., 1/2, 1, 2, 3, etc.). The delivery pressure is entered into the DIS system, and the billing computer then applies appropriate pressure, temperature, and supercompressibility multipliers to

*This document is considered CONTROLLED only when viewed electronically on the Company's intranet. Printed or other electronic copies may not be current, and the intranet version should be used to verify.*



Distribution Operations

|                               |  |   |
|-------------------------------|--|---|
| Effective Date:<br>10/01/2004 | <b>Fixed Pressure Factor Metering<br/>(FPFM)</b> | Standard Number:<br><b>GS 6400.090(CG)</b><br>P&P 724-9 |
| Supersedes:<br>N/A            |  | Page 2 of 4   |

calculate an accurate volume for billing.

**2.2 Fixed Pressure Compensating Index/Instrument (FPCI)**

FPCI is accomplished by an instrument that applies the appropriate pressure and supercompressibility multipliers so that the index will register meter volumes corrected to predetermined base pressure conditions. One method to accomplish FPCI is by the use of specially geared indexes, but this method is no longer a desired practice.

**3. INSTALLATION CRITERIA**

All FPFM installations shall be designed in accordance with the company's M&R Standard Drawing Manual, the Large Volume Design/Process Manual, or as specified by Engineering or M&R Operations.

FPFM installations are limited to the following conditions:

- a. Maximum 20 psig delivery pressure,
- b. Delivery pressure must be maintained to +/- 1% of the desired absolute pressure (psia) during flow, and
- c. Company-owned facilities, which do not provide gas to any external customers, can deliver over 20 psig, in 5-psi increments, to 100 psig. For these installations, a delivery in psig must be maintained to +/- 2% of the desired absolute pressure during flow.

Due to the increased operational costs of FPFM (as compared to standard low pressure service) an economic evaluation should be completed prior to the installation of FPFM.

**4. ESTABLISHING AN FPFM BILLING ACCOUNT**

When an FPFM meter set assembly is installed and is ready to be placed into operation, a DIS order shall be completed indicating the pressure compensation code and the temperature compensation code. Form C 2245 (Exhibit A) shall be completed indicating the specified delivery pressure and forwarded appropriately.

In situations where FPFM is treated for billing purposes as a GMB account (for special rate conditions) the meter readings shall be recorded and communicated to the Gas Volume Measurement section.

Inspection schedules for FPFM accounts remain the same regardless of how they are treated with respect to meter reading and billing.



Distribution Operations

|                               |  |   |
|-------------------------------|--|---|
| Effective Date:<br>10/01/2004 | <b>Fixed Pressure Factor Metering<br/>(FPFM)</b> | Standard Number:<br><b>GS 6400.090(CG)</b><br>P&P 724-9 |
| Supersedes:<br>N/A            |  | Page 3 of 4   |

**5. PRESSURE VERIFICATION FOR INSTALLATION OR DELIVERY PRESSURE CHANGE**

Whenever a new FPFM meter set is installed, the meter and/or control service regulator shall be clearly labeled with the FPFM delivery pressure.

An initial inspection shall be performed to determine that the regulator delivers the proper pressure.

If a pressure verification inspection cannot be made because there is not adequate flow, the inspection should be made as soon as practical at a time when there is a gas load representative of normal usage.

**6. REGULATOR PRESSURE VERIFICATION SCHEDULE**

Verification of the service regulator set pressure (specified delivery pressure) on FPFM accounts shall be performed as per:

- a. Accounts that are 2 psig or under AND have a meter capacity of 1.5 Mcfh or under, shall be verified at time of meter change or test.
- b. Accounts that are greater than 2 psig OR have a meter capacity greater than 1.5 Mcfh shall be verified every 5 years or according to specific state commission regulations, if more frequent.
- c. After pressure verification, ensure that the FPFM pressure is correct in the billing computer.

If the specified delivery pressure is not within the established tolerance, appropriate repairs and/or adjustments shall be made to the service regulator. The "As found" and "As left" pressures shall be recorded on Form C 2245 (see Exhibit A) for use in making any billing adjustments that may be required.



Distribution Operations

|                               |  |   |
|-------------------------------|--|---|
| Effective Date:<br>10/01/2004 | <b>Fixed Pressure Factor Metering<br/>(FPFM)</b> | Standard Number:<br><b>GS 6400.090(CG)</b><br>P&P 724-9 |
| Supersedes:<br>N/A            |  | Page 4 of 4   |

**EXHIBIT A**

FORM C 2245  
(06-04)

**FIXED PRESSURE COMPENSATION BY COMPUTER  
(FPCC)**

|  |  |          |          |
|--|--|----------|----------|
| NAME   |  | PSID     |          |
| ADDRESS  |  |          |          |
| CITY   |  | STATE    | ZIP CODE |
| TYPE OF PRESSURE CHECK<br><input type="checkbox"/> NEW <input type="checkbox"/> CHANGE <input type="checkbox"/> VERIFICATION |  |          |          |
| ACTUAL GAS DELIVERY PRESSURE (PSIG)*<br>ENTER IN THE APPROPRIATE DATA FORMAT   |  | AS FOUND |          |
|  |  | AS LEFT  |          |
| INSTALLED / VERIFIED BY (FIELD)  |  |          | DATE     |
| ENTERED BY (ACCOUNT PROCESSING)  |  |          | DATE     |

\*PRESSURE TO BE 1/2, 1, 2, 3, ..., 20 PSIG (MAXIMUM)  
 THIS FORM IS TO BE FORWARDED FOR ACCOUNT PROCESSING.



**Gas Standard**

Distribution Operations

|                               |   |  |
|-------------------------------|---|--|
| Effective Date:<br>01/01/2006 | <b>Witness Testing of Points of Delivery (POD) Measuring Stations</b> | Standard Number:<br><b>GS 6400.100(CG)</b><br>P&P 724-10 |
| Supersedes:<br>N/A            |   | Page 1 of 2  |

Companies Affected:

|                                     |   |   |
|-------------------------------------|---|---|
| <input type="checkbox"/> NIPSCO     | <input checked="" type="checkbox"/> CGV | <input checked="" type="checkbox"/> CMD |
| <input type="checkbox"/> NIFL       | <input checked="" type="checkbox"/> CKY | <input checked="" type="checkbox"/> COH |
| <input type="checkbox"/> Kokomo Gas | <input type="checkbox"/> CMA            | <input checked="" type="checkbox"/> CPA |

**REFERENCE** Columbia Gas LDC's Measurement Information Guide

**1. GENERAL**

The Columbia Gas distribution companies of NiSource, Inc, (NDO-CG) have contracts with companies to deliver gas supplies into their distribution systems, and further, have the contractual right to on-site witness test the calibration, operation, and maintenance of the measurement facilities at these points of delivery (POD's) to assure measurement accuracy. On-site witness testing will be performed to prevent and/or correct over-bill situations.

**2. ON-SITE WITNESS TESTING SCHEDULE**

Energy Supply Service-Gas Control will provide to NDO-CG systems Operation management (or designee) an annual listing of the measuring stations delivering volumes to NDO-CG. The System Operations management (or designee) will review the list of stations, and determine which stations are to be witness-tested each year. The determination will be based on a consideration of all supply measuring stations not already maintained by ND)-CG and accumulatively contribute up to, and including, 70% of the total annual volume, according to the following guidelines:

- a. Those stations with delivery volumes greater than or equal to 2% of the total annual throughput shall be witness tested.
- b. The remainder of the stations will have a 20% witnessed by random sampling.
- c. Those stations that are suspect due to past performance, if not already included in other criteria.

**3. WITNESS TESTING PROCEDURE**

Witness test shall be performed by persons familiar with measurement and regulation equipment, and test procedures for POD's. M&R personnel shall witness, verify, and document on-site tests as conducted by the POD operator. All tests and test information

*This document is considered CONTROLLED only when viewed electronically on the Company's intranet. Printed or other electronic copies may not be current, and the intranet version should be used to verify.*



Distribution Operations

|                               |   |  |
|-------------------------------|---|--|
| Effective Date:<br>01/01/2006 | <b>Witness Testing of Points of<br/>Delivery (POD) Measuring Stations</b> | Standard Number:<br><b>GS 6400.100(CG)</b><br>P&P 724-10 |
| Supersedes:<br>N/A            |   | Page 2 of 2  |

from all measuring equipment shall be documented in accordance with the Measurement Informational Guide.

**4. OVER BILLS AND REFUNDS**

Every attempt should be made to identify, correct, and document any on-site discrepancies that may result in an over-bill situation. In the event that a discrepancy is found which has caused, or may in the future cause, an over-bill situation for NDO-CG, a copy of all documentation shall be forwarded to Energy Supply Services – Procurement so a refund from the appropriate party may be obtained.



Distribution Operations

|                               |  |  |
|-------------------------------|--|--|
| Effective Date:<br>07/12/2005 | <b>Schedules for Testing and<br/>                 Inspecting Gas Measurement<br/>                 Facilities; Certification and<br/>                 Tolerances for Gas Measurement<br/>                 Testing Equipment</b> | Standard Number:<br><b>GS 6400.110(CG)</b><br>P&P 724-11 |
| Supersedes:<br>N/A            |  | Page 1 of 7  |

Companies Affected:

|                                     |   |   |
|-------------------------------------|---|---|
| <input type="checkbox"/> NIPSCO     | <input checked="" type="checkbox"/> CGV | <input checked="" type="checkbox"/> CMD |
| <input type="checkbox"/> NIFL       | <input checked="" type="checkbox"/> CKY | <input checked="" type="checkbox"/> COH |
| <input type="checkbox"/> Kokomo Gas | <input type="checkbox"/> CMA            | <input checked="" type="checkbox"/> CPA |

**REFERENCE** Columbia Gas LDCs' "M&R Handbook"

**1. DEFINITIONS**

A "Gas Measurement Facility" is defined as a meter that uses a mechanical or electronic correcting device to compensate for elevated pressure.

A "Gas Measurement Station" is defined as all equipment and piping, in conjunction with one or more Gas Measurement Facility(s), providing service to a single customer.

"Gas Measurement Testing Equipment" is defined as devices used for checking the accuracy of, or used for calibrating, all sensing or measuring equipment at Gas Measurement Stations.

**2. REQUIREMENTS**

All new Gas Measurement Facilities shall be tested and/or inspected on location prior to being placed in service, or as soon as possible thereafter.

In no event shall testing and/or inspections occur less frequently or by less stringent standards or procedures than may be required in contracts and agreements, by tariffs, or by state regulatory commissions.

Personnel performing the testing and/or inspection of the Gas Measurement Facilities shall be responsible for recommending to the supervisor more frequent tests and/or inspections as warranted by local operating conditions. The supervisor or designee shall be responsible for determining if more frequent testing and/or inspection are warranted, and if so, they shall ensure that the tests and/or inspections are properly scheduled. The reason for the more-frequent test and/or inspection should be documented.

**2.1 Active Meters**

The minimum test and/or inspection schedules for active meters, instruments and

*This document is considered CONTROLLED only when viewed electronically on the Company's intranet. Printed or other electronic copies may not be current, and the intranet version should be used to verify.*



Distribution Operations

|                               |  |  |
|-------------------------------|--|--|
| Effective Date:<br>07/12/2005 | <b>Schedules for Testing and Inspecting Gas Measurement Facilities; Certification and Tolerances for Gas Measurement Testing Equipment</b> | Standard Number:<br><b>GS 6400.110(CG)</b><br>P&P 724-11 |
| Supersedes:<br>N/A            |  | Page 2 of 7  |

auxiliary equipment installed at Gas Measurement Stations are shown in Exhibit A. These schedules apply to all measuring facilities owned or maintained by the company.

**2.2 Inactive Meters**

All inactive meters may be excluded from stated minimum test schedules during the period of shut off. When inactive meters are activated, or as soon as possible thereafter, a test/inspection shall be performed if any required tests/inspections were due during the inactive period.

All inactive meters (including inactive meters in parallel runs) shall be reviewed after a period of 12 months to determine if the meter should be removed. If an inactive meter is removed, the inlet and outlet piping shall be blind plated and inlet meter riser and bypass valves locked and sealed.

All inactive meters shall be checked during a scheduled visit (e.g., at time of leakage inspection) at least annually for no registration of gas. Any registration shall be reported for billing and to the supervisor for investigation.

**2.3 Tolerances**

The "Operating Tolerances" for the test and/or inspection of meters and auxiliary measurement equipment are the acceptable tolerances permitted, and are the allowable accuracy deviations from 100%. These tolerances are located in the "M&R Handbook." Adjustments shall be made to the equipment when these tolerances are exceeded. In no case shall the tolerances be left outside those tolerances permitted by the appropriate state regulatory commission or by a gas purchase contract.

The "Billing Tolerances" for the test and/or inspection of gas measurement equipment are the allowable accuracy deviations from 100%. These tolerances are located in the "M&R Handbook." Billing adjustments shall be made by the Gas Volume Measurement Section when these tolerances are exceeded.

**3. RESPONSIBILITY**

**3.1 Tests, Inspections, and Reported Results**

The supervisor or designee shall be responsible for:





Distribution Operations

|                               |  |  |
|-------------------------------|--|--|
| Effective Date:<br>07/12/2005 | <b>Schedules for Testing and Inspecting Gas Measurement Facilities; Certification and Tolerances for Gas Measurement Testing Equipment</b> | Standard Number:<br><b>GS 6400.110(CG)</b><br>P&P 724-11 |
| Supersedes:<br>N/A            |  | Page 3 of 7  |

- a. Maintaining compliance with test and inspection schedules, operating and billing tolerances.
- b. Assuring that tests and/or inspections are being conducted in accordance with approved procedures.
- c. Reviewing completed forms and Gas Measurement DIS Orders to assure that all data is complete.
- d. Verifying all test data for conformance to required standards and taking any necessary corrective action.
- e. Proper routing and maintenance of all forms and Gas Measurement DIS Orders to the supervisor responsible for posting.
- f. Communicating the necessary information to the Gas Volume Measurement Section, when billing adjustments are required.

**3.2 Certification of Gas Measurement Testing Equipment**

The supervisor or designee shall be responsible to ensure company certification of Gas Measurement Testing Equipment in accordance with the schedule shown in Exhibit B. Certification shall be performed by a check against a certified reference standard, or "once-removed" certified unit. A dated record of all scheduled (e.g., via WMS RT) and performed (e.g., via WMS JO) tests shall be maintained. The schedules, shown in Exhibit B, shall be in effect, except where state regulatory requirements are more stringent. In such instances, the more stringent schedule shall take precedence.

All meter testing equipment shall be tested against a certified reference standard. Damaged or malfunctioning test equipment shall be certified after it is repaired.



Distribution Operations

|                               |  |  |
|-------------------------------|--|--|
| Effective Date:<br>07/12/2005 | <b>Schedules for Testing and Inspecting Gas Measurement Facilities; Certification and Tolerances for Gas Measurement Testing Equipment</b> | Standard Number:<br><b>GS 6400.110(CG)</b><br>P&P 724-11 |
| Supersedes:<br>N/A            |  | Page 4 of 7  |

**EXHIBIT A  
(1 of 2)**

**MINIMUM REQUIREMENTS FOR TESTING AND/OR INSPECTING  
DIAPHRAGM, ROTARY, AND TURBINE METERS; INSTRUMENTS; AND  
AUXILIARY MEASUREMENT EQUIPMENT**

| DEVICE TYPE AND TEST <sup>(NOTES)</sup>   | SCHEDULE   |
|---|--|
| 1. DIAPHRAGM METERS<br>a. Accuracy Test   | Every 3 years for all sizes<br><u>Exception for CKY:</u><br>Every 2 years for meters over 1,500 cfh badged capacity            |
| 2. ROTARY METERS<br>a. Oil Change<br><br>b. Differential Test <sup>(1)</sup><br>c. Accuracy Test <sup>(1, 2)</sup><br>d. Temperature Compensating (TC) Element (if applicable)  | At the first scheduled inspection following installation, then<br>As needed<br>Annually<br>As needed<br>Annually               |
| 3. TURBINE METERS<br>a. Lubrication<br>b. Spin Time Tests – Adjusting & Non-Adjusting Meters <sup>(3)</sup><br>c. Module Change <sup>(3)</sup>  | Annually<br>Annually<br>As Needed  |
| 4. PRESSURE & TEMPERATURE CORRECTING DEVICES<br>a. Pressure Check at Operating Pressure<br>b. 3-point Pressure Test, at:<br>operating pressure,<br>a point 0-10% of scale, and<br>a point 90-100% of scale<br>c. Temperature Check at Operating Temperature<br>d. 3-point Temperature Test, at:<br>operating temperature,<br>a point 32°-42°F, and<br>a point 90°-120°F | Annually<br>As Needed, such as upon operating check failure<br><br>Annually<br>As Needed, such as upon operating check failure |
| 5. AUXILIARY EQUIPMENT<br>a. Inspect Straightening Vanes and Strainers <sup>(4)</sup><br>b. Inspect Inline Filters <sup>(5, 6)</sup><br>c. Inspect Limit Flow Controller Setpoints  | Every 4 years<br>Annually<br>As Needed   |
| 6. STATION PIPING<br>a. Inspect Station Piping for Leakage  | Annually   |



Distribution Operations

|                               |  |  |
|-------------------------------|--|--|
| Effective Date:<br>07/12/2005 | <b>Schedules for Testing and Inspecting Gas Measurement Facilities; Certification and Tolerances for Gas Measurement Testing Equipment</b> | Standard Number:<br><b>GS 6400.110(CG)</b><br>P&P 724-11 |
| Supersedes:<br>N/A            |  | Page 5 of 7  |

**EXHIBIT A  
(2 of 2)**

**MINIMUM REQUIREMENTS FOR TESTING AND/OR INSPECTING DIAPHRAGM, ROTARY, AND TURBINE METERS; INSTRUMENTS; AND AUXILIARY MEASUREMENT EQUIPMENT**

NOTES:

- (1) All states accept a differential pressure test as verification that the initial accuracy of the rotary meter has not appreciably changed. Differential tests should be compared to the manufacturers' factory test and/or the tests performed during the initial installation.
- (2) Rotary and turbine meters shall be prover-tested after any repairs that might significantly affect meter accuracy.
- (3) If successful spin time tests cannot be achieved, the spin time test shall be repeated after field repairs/maintenance is performed. If minimum spin times still cannot be achieved, the module shall be scheduled for replacement.
- (4) Straightening vanes and strainers shall be visually inspected at the time of the first scheduled instrument testing after turn on. If the integrity of the straightening vanes and/or strainer element is compromised and cannot be restored, it shall be replaced. Common Y-type strainers should be given a visual internal inspection through the inspection blow-down fitting on the main plug. If the strainer cannot be cleared, replace the entire strainer.
- (5) Filters may either be visually inspected or inspected by conducting a differential test. If the differential pressure across the filter unit exceeds 5 psi, the filter element(s) shall be replaced.
- (6) Filters shall be inspected within a few days after placing the station in service, and on an annual schedule thereafter, unless gas conditions indicate more



**Gas Standard**

Distribution Operations

|                               |  |  |
|-------------------------------|--|--|
| Effective Date:<br>07/12/2005 | <b>Schedules for Testing and Inspecting Gas Measurement Facilities; Certification and Tolerances for Gas Measurement Testing Equipment</b> | Standard Number:<br><b>GS 6400.110(CG)</b><br>P&P 724-11 |
| Supersedes:<br>N/A            |  | Page 6 of 7  |

frequent inspection is warranted. If the integrity of the filter unit is compromised and cannot be restored, it shall be replaced.



Distribution Operations

|                               |  |  |
|-------------------------------|--|--|
| Effective Date:<br>07/12/2005 | <b>Schedules for Testing and Inspecting Gas Measurement Facilities; Certification and Tolerances for Gas Measurement Testing Equipment</b> | Standard Number:<br><b>GS 6400.110(CG)</b><br>P&P 724-11 |
| Supersedes:<br>N/A            |  | Page 7 of 7  |

**EXHIBIT B**

**SCHEDULE FOR CERTIFICATION OF GAS MEASUREMENT TESTING EQUIPMENT**

| <b>TYPE OF EQUIPMENT</b>                   | <b>REQUIRED ACCURACY</b>                          | <b>SCHEDULE*</b>             |
|--|---|------------------------------|
| Electronic Digital Pressure Indicator      | ± 0.05% of Reading<br>± 0.01% Full Scale          | Continuous and annually      |
| Electronic Digital Thermometer             | ± 0.2° F  | Continuous and annually      |
| Deadweight Tester                          | ± 0.1% of Indicated Pressure                      | Continuous and every 3 years |
| Field Transfer Prover (Diaphragm & Rotary) | ± 0.3% of Reference Standard Meter                | Continuous and every 5 years |
| Spring Pressure Check Gauge                | ± 5% for Portable<br>± 2% for Permanently Mounted | Continuous and annually      |
| Dewpoint Tester                            | N/A   | New                          |
| Water Sensor Vapor Probe                   | ± 2° C  | Continuous and every 3 years |
| Electronic Digital Manometer               | ± 0.05% of Full Scale                             | Continuous and annually      |

\*NOTE: A continuous schedule requires a visual inspection for defects, damage, and abnormal operation prior to, or during, each use.  
Equipment suspected to be operating abnormally should be checked against a similar device to determine if calibration is needed.  
Equipment that does not meet the required accuracy shall be calibrated to a reference standard.



Distribution Operations

|                               |   |  |
|-------------------------------|---|--|
| Effective Date:<br>04/30/1996 | <b>Gas Measurement Forms and DIS<br/>Orders</b> | Standard Number:<br><b>GS 6400.130(CG)</b><br>P&P 724-13 |
| Supersedes:<br>N/A            |   | Page 1 of 8  |

Companies Affected:

|                                     |   |   |
|-------------------------------------|---|---|
| <input type="checkbox"/> NIPSCO     | <input checked="" type="checkbox"/> CGV | <input checked="" type="checkbox"/> CMD |
| <input type="checkbox"/> NIFL       | <input checked="" type="checkbox"/> CKY | <input checked="" type="checkbox"/> COH |
| <input type="checkbox"/> Kokomo Gas | <input type="checkbox"/> CMA            | <input checked="" type="checkbox"/> CPA |

**REFERENCE** Measurement Informational Guide

**1. GENERAL REQUIREMENTS**

**1.1 Gas Measurement Forms**

The term "Gas Measurement forms" shall include:

- a. Form C-3133, "Measuring Station Inspection Record," Exhibit A, and
- b. Form C-926, "Meter Reading and Measuring Station Log," Exhibit B.

**1.2 Gas Measurement DIS Orders**

**1.2.1 Turning Gas On or Transfer Billing**

The following DIS Orders are used to turn gas on or to transfer billing:

- a. Connect (CN)
- b. Reconnect (RC)
- c. On Non-Pay (NP)
- d. Old Set (OS)
- e. New Set (NS)

**1.2.2 Investigating Customer Account Billing**

The following DIS Orders are used to investigate customer account billing:

- a. Read Meter (RD)
- b. Re-Read Meter (RR)
- c. High Bill (HB)

*This document is considered CONTROLLED only when viewed electronically on the Company's intranet. Printed or other electronic copies may not be current, and the intranet version should be used to verify.*



Distribution Operations

|                               |   |  |
|-------------------------------|---|--|
| Effective Date:<br>04/30/1996 | <b>Gas Measurement Forms and DIS Orders</b> | Standard Number:<br><b>GS 6400.130(CG)</b><br>P&P 724-13 |
| Supersedes:<br>N/A            |   | Page 2 of 8  |

d. Consumption History (CH)

**1.2.3 Investigating Emergency Situations**

The Priority (PR) DIS Order is used to investigate emergency situations, such as carbon monoxide symptoms, odor of gas, etc.

**1.2.4 Obtaining a Final Reading, Turn Off Gas Service and Issue a Final Bill**

The Disconnect (DC) DIS Order is used to obtain a final reading, turn off gas service and issue a final bill. A Remove Active (RA) DIS Order may also be used for this purpose.

**1.2.5 Performing Inspections, Tests, Maintenance and Equipment Changeouts**

The following DIS Orders are used to perform inspections, tests, maintenance and measurement equipment changeouts:

- a. Test On Premise (TP)
- b. Meter Change (MC)
- c. Equipment Change (EC)
- d. By-Passed Gas (BG)

Note: When a field transfer prover test is performed, an “as found” printout of the detailed test data shall be filed with the hard copy of the Test On Premise (TP) Order.

**1.2.6 Performing Witness Testing at Gas Purchase Points**

The Witness Test (WT) DIS Order is used to perform witness testing at gas purchase points.

**1.2.7 Miscellaneous DIS Orders**

The following are the remaining miscellaneous DIS Orders:

- a. Consult - New Set (CL)
- b. Consult - Existing Lines (SC)
- c. Inspect Lines - New Set (IS)



Distribution Operations

|                               |   |  |
|-------------------------------|---|--|
| Effective Date:<br>04/30/1996 | <b>Gas Measurement Forms and DIS Orders</b> | Standard Number:<br><b>GS 6400.130(CG)</b><br>P&P 724-13 |
| Supersedes:<br>N/A            |   | Page 3 of 8  |

- d. Inspect Lines - Existing (SI)
- e. Remove Active (RA)
- f. Remove Inactive (RI)
- g. Service Order (SO)
- h. CSL Follow-up (CS)
- i. Carbon Monoxide (CO)

**2. 2. MAINTENANCE RESPONSIBILITY**

**2.1 Gas Measurement Forms**

The supervisor is responsible for assuring that a Measuring Station Inspection Record is completed and on-site for each meter. For rotary meter CAB accounts, the Measuring Station Inspection Record shall be filed at the local office.

**2.2 Gas Measurement DIS Orders**

The supervisor is responsible for ensuring that the Gas Measurement DIS Orders are reviewed to assure compliance with schedules, procedures and rulings, then executed and filed.

**3. FILING AND RETENTION**

Completed Gas Measurement forms shall be retained for one year. Gas Measurement DIS Orders shall be indexed and retained for a period of seven (7) years.

**4. COMPLETION OF GAS MEASUREMENT DIS ORDERS AND GAS MEASUREMENT FORMS**

The Measuring Station Inspection Record shall be used to record all inspections and tests. This form is intended to provide a reference at the measurement station.

The Meter Reading and Measuring Station Log may be used to schedule, plan and record all inspections, tests, required maintenance, chart changing and meter/instrument readings.

Gas Measurement DIS Orders shall be completed and executed each time a measuring station or CAB meter setting is visited, except for visits solely for the purposes of chart changing and/or meter/instrument readings. Any physical change, adjustment, test, inspection or maintenance requires the completion and execution of a Gas Measurement





**Gas Standard**

Distribution Operations

|                               |   |  |
|-------------------------------|---|--|
| Effective Date:<br>04/30/1996 | <b>Gas Measurement Forms and DIS<br/>Orders</b> | Standard Number:<br><b>GS 6400.130(CG)</b><br>P&P 724-13 |
| Supersedes:<br>N/A            |   | Page 4 of 8  |

DIS Order. Gas Measurement DIS Orders shall be executed in DIS no later than five (5) working days after the completion of the order.

Refer to the Measurement Informational Guide for information and examples related to the completion of Gas Measurement forms and DIS Orders.





**Gas Standard**

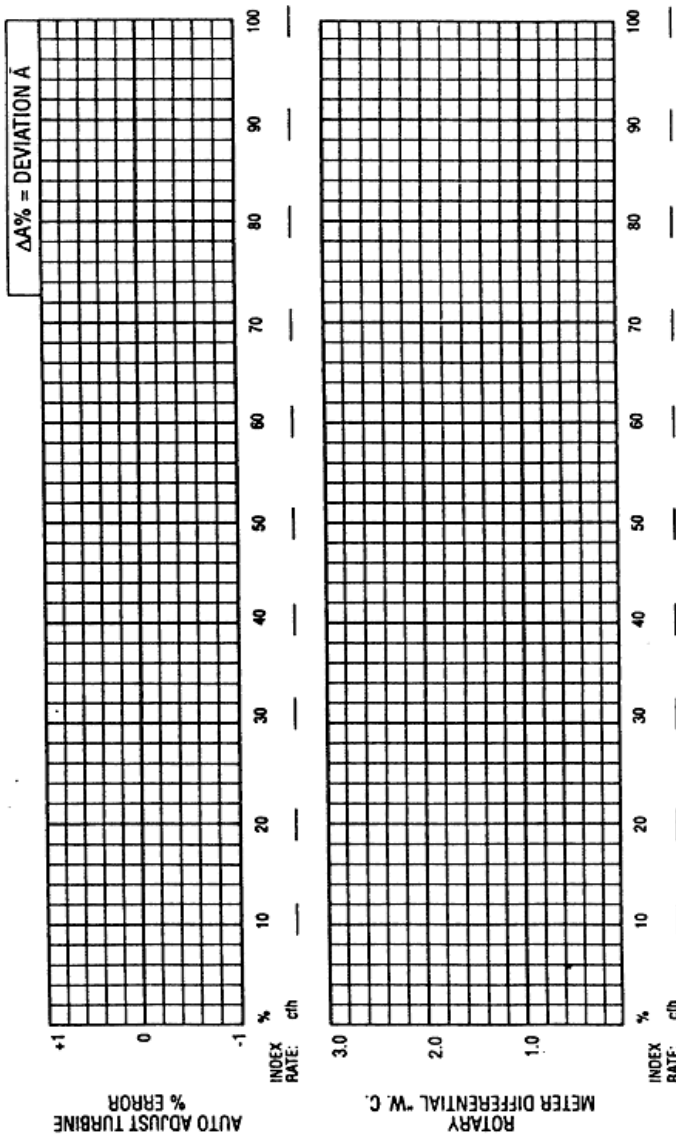
Distribution Operations

|                               |   |  |
|-------------------------------|---|--|
| Effective Date:<br>04/30/1996 | <h2>Gas Measurement Forms and DIS Orders</h2> | Standard Number:<br><b>GS 6400.130(CG)</b><br>P&P 724-13 |
| Supercedes:<br>N/A            |   | Page 6 of 8  |

**EXHIBIT A  
(2 of 2)**

BACK OF FORM

AVERAGE OPERATING PRESSURE OF \_\_\_\_\_  
PSIA  
PSIG





**Gas Standard**

Distribution Operations

|                               |   |  |
|-------------------------------|---|--|
| Effective Date:<br>04/30/1996 | <b>Gas Measurement Forms and DIS Orders</b> | Standard Number:<br><b>GS 6400.130(CG)</b><br>P&P 724-13 |
| Supercedes:<br>N/A            |   | Page 7 of 8  |

**EXHIBIT B  
(1 of 2)**

FRONT OF FORM

| METER READING AND MEASURING STATION LOG   |              |          |         |              |   |              |                    |                    |      |  |
|---|--------------|----------|---------|--------------|---|--------------|--------------------|--------------------|------|--|
| MEASURING STATION NUMBER  |              |          |         |              |   |              |                    |                    | PSID |  |
| From _____  |              |          |         |              | To _____  |              |                    |                    |      |  |
| Meter Serial No. _____  |              |          |         |              | Service Address _____   |              |                    |                    |      |  |
| Meter: K & S, WP _____  |              |          |         |              | Customer Contact _____  |              |                    |                    |      |  |
| Capacity (2" W.C.) _____ Cfh  |              |          |         |              | Station Status: <input type="checkbox"/> Active <input type="checkbox"/> Inactive   |              |                    |                    |      |  |
| Meter Install Date _____  |              |          |         |              | Base Pressure _____ Meter Class <input type="checkbox"/> I <input type="checkbox"/> II  |              |                    |                    |      |  |
| INSTRUMENTS   |              |          |         |              |   |              |                    |                    |      |  |
| Manufacturer _____  |              |          |         |              | Model _____ Chart Type _____  |              |                    |                    |      |  |
| Instrument Serial No. _____   |              |          |         |              | Chart CGS # _____ Chart Rotation: Hrs. <input type="checkbox"/> Days <input type="checkbox"/>   |              |                    |                    |      |  |
| Pressure Range _____ PSIG <input type="checkbox"/> PSIA <input type="checkbox"/>  |              |          |         |              | Mcf per revolution/Scallop _____  |              |                    |                    |      |  |
| Temperature Range _____   |              |          |         |              | EM ID: _____  |              |                    |                    |      |  |
| Telemetering: <input type="checkbox"/> Yes <input type="checkbox"/> No  |              |          |         |              | Power Supply: <input type="checkbox"/> AC <input type="checkbox"/> Solar <input type="checkbox"/> Batt.   |              |                    |                    |      |  |
| EFC Phone No. ( ) _____   |              |          |         |              |   |              |                    |                    |      |  |
| (As Left) Results of Last Prover Test   |              |          |         |              |   |              |                    |                    |      |  |
| Test Flow Rates   |              |          | ▶       | CHECK        | MID   | OPEN         |                    |                    |      |  |
| (As Left) Final Accuracy %  |              |          |         |              |   |              |                    |                    |      |  |
| Mileage Allowed _____ Mcf   |              |          |         |              | at _____ PSIG/PSIA  |              |                    |                    |      |  |
| REGULATION  |              |          |         |              |   |              |                    |                    |      |  |
| SIZE S.W.P.   | MANUFACTURER | FUNCTION | ORIFICE | SPRING COLOR | SPRING RANGE  | INLET PRESS. | CONTROL SET PRESS. | MONITOR SET PRESS. |      |  |
|   |              |          |         |              |   |              |                    |                    |      |  |
|   |              |          |         |              |   |              |                    |                    |      |  |
| GI = Gauge Inspection (1 point)<br>MT = Meter Accuracy Test (Prover)<br>MC = Meter/Module Change<br>DT = Differential Test<br>GC = Gauge Calibration (3 points)<br>SI = Strainer Inspection<br>FI = Filter Inspection<br>VI = Vane Inspection<br>TD = Turbine Deviation Test<br>BT = BTU Test<br>ML = Meter Lubrication |              |          |         |              | OC = Oil Change<br>ST = Spin Tests<br>CI = Controller Inspection<br>LK = Station Leakage Test<br>BC = Battery Change<br>/ = Work Due<br>X = Work Completed<br>MR = Meter Read/Chart Change<br>OI = Orifice Meter Inspection<br>QT = Gas Quality Test<br>WT = Witness Test |              |                    |                    |      |  |
| REMARKS:  |              |          |         |              |   |              |                    |                    |      |  |





Distribution Operations

|                               |   |  |
|-------------------------------|---|--|
| Effective Date:<br>07/15/1981 | <b>Mailing of Meter Charts, Records and Reports - Gas Measurement Billing (GMB)</b> | Standard Number:<br><b>GS 6400.140(CG)</b><br>P&P 724-14 |
| Supersedes:<br>N/A            |   | Page 1 of 12   |

Companies Affected:

|                                     |   |   |
|-------------------------------------|---|---|
| <input type="checkbox"/> NIPSCO     | <input checked="" type="checkbox"/> CGV | <input checked="" type="checkbox"/> CMD |
| <input type="checkbox"/> NIFL       | <input checked="" type="checkbox"/> CKY | <input checked="" type="checkbox"/> COH |
| <input type="checkbox"/> Kokomo Gas | <input type="checkbox"/> CMA            | <input checked="" type="checkbox"/> CPA |

**REFERENCE** None

**1. GENERAL REQUIREMENTS**

Meter charts, records and reports for GMB facilities owned by CDC shall be mailed to the CDC Gas Measurement Section in Columbia, Ohio (see Section 3).

Meter charts, records and reports for dual purpose measuring facilities owned by TCO which involve a direct sale to a CDC GMB customer shall be mailed to the CDC Gas Measurement Section in Columbus, Ohio (see Section 3).

Meter charts, records and reports for measurement facilities owned by TCO, except dual purpose measuring facilities, shall be mailed to the TCO Gas Measurement Section in Charleston, W. Virginia (see Section 4).

It is imperative that meter charts, records and reports be mailed promptly to the appropriate Gas Measurement Section because late and/or incorrect mailing may result in billing delays.

The return address of the mailing location shall be included on all mail.

**2. APPLICABLE METER CHARTS, RECORDS AND REPORTS**

**2.1 Meter Charts**

1. Circular recording charts installed on diaphragm, rotary, turbine and orifice meter gauges, temperature recording gauges and gravimeters.
2. Strip charts from those calorimeters which are used for billing purposes.

**2.2 Meter Reading Records**

1. All displacement meter reading records, "Meter Reading Card" Form CS 6-199, and "Displacement Meter Reading Record" Form CS 6-175. These card forms are included as Exhibit A.

*This document is considered CONTROLLED only when viewed electronically on the Company's intranet. Printed or other electronic copies may not be current, and the intranet version should be used to verify.*



Distribution Operations

|                               |   |  |
|-------------------------------|---|--|
| Effective Date:<br>07/15/1981 | <b>Mailing of Meter Charts, Records<br/>and Reports - Gas Measurement<br/>Billing (GMB)</b> | Standard Number:<br><b>GS 6400.140(CG)</b><br>P&P 724-14 |
| Supersedes:<br>N/A            |   | Page 2 of 12   |

**2.3 Metering Equipment Change Report**

Send a duplicate copy to the Gas Measurement Section of all Metering Equipment Change Reports (MECR), Form CS 6-2-3. This form is included as Exhibit B. Refer to [GS 6400.170\(CG\)](#) "Metering Equipment Change Report (MECR) - Gas Measurement Billing (GMB)."

**2.4 Meter Test and Inspection Reports**

Send a duplicate copy to the Gas Measurement Section of those meter test and inspection reports which affect billing, such as:

- a. Field tolerances which exceed those shown in the fourth column of Form CS 6-9, "Field Tolerances for Meters and Metering Equipment" (Exhibit C).
- b. Estimates necessitated due to bypassed gas, index build-up or metering equipment out of service or registering inaccurately. Refer to [GS 6400.230\(CG\)](#) "Furnishing Gas Estimates for Billing - Gas Measurement Billing (GMB)."
- c. An abnormal operating condition exists that may affect billing.

**3. MAILING TO THE COLUMBIA GAS DISTRIBUTION COMPANIES (CDC) GAS MEASUREMENT SECTION**

Meter charts, records and reports are to be mailed to:

COLUMBIA GAS DISTRIBUTION COMPANIES  
Gas Measurement Section  
Room 326  
99 North Front Street  
Columbus, Ohio 43215

To facilitate the mailing, two (2) types of envelopes, pre-printed with the above address, are available from the Columbia Gas Distribution Companies, Stationery Warehouse, 4188 Fisher Road, Columbus, Ohio, 43228. These are:

1. A 12" x 12" envelope for all meter charts and those meter records or reports which must be attached to the charts, Form C 540-1, included as Exhibit D.
2. A 6" x 9-1/2" envelope for meter records and reports, Form C 1659, included as Exhibit E.



Distribution Operations

|                               |   |  |
|-------------------------------|---|--|
| Effective Date:<br>07/15/1981 | <b>Mailing of Meter Charts, Records<br/>and Reports - Gas Measurement<br/>Billing (GMB)</b> | Standard Number:<br><b>GS 6400.140(CG)</b><br>P&P 724-14 |
| Supersedes:<br>N/A            |   | Page 3 of 12   |

Note: All Columbus mailing envelopes are not postage pre-paid. Therefore, arrangements for providing the necessary postage shall be made.

**4. MAILING TO THE COLUMBIA GAS TRANSMISSION CORPORATION (TCO) GAS MEASURE-MENT SECTION**

Meter charts, records and reports are to be mailed to:

COLUMBIA GAS TRANSMISSION CORPORATION  
Gas Measurement Section  
P. O. Box 1273  
Charleston, West Virginia 25325

To facilitate mailing to the TCO Gas Measurement Section, two (2) types of postage pre-paid envelopes, pre-printed with the above address, are available from the Columbia Gas Distribution Companies, Stationery Warehouse, 4188 Fisher Road, Columbus, Ohio, 43228.

These are:

- \*(1) A 12-1/4" x 12-1/4" envelope for all meter charts and those meter records and reports which must be attached to the charts, included as Exhibit F.
- (2) A 5" x 11-1/2" envelope for meter records and reports, Form 1409-GM5, included as Exhibit G.

\*No form number assigned to these envelopes, therefore, when ordering, state Columbia Gas Transmission Corporation Chart Envelopes, and size.

**5. MAILING WITHIN THE DISTRICT**

The meter inspector is responsible for forwarding the original (first copy) of all Metering Equipment Change Reports and Meter Test and Inspection Reports to the District Service Manager or Division Service Supervisor for review and filing. Refer to [GS 6400.170\(CG\)](#) "Metering Equipment Change Report (MECR) - Gas Measurement Billing (GMB)."

When operating conditions warrant, meter reports may be processed and filed by a specified individual at a central location designated by CDC or TCO Management. Refer to [GS 6400.130\(CG\)](#) "Maintaining District Meter Reports - Gas Measurement Billing (GMB)."





|                               |   |  |
|-------------------------------|---|--|
| Effective Date:<br>07/15/1981 | <b>Mailing of Meter Charts, Records<br/>and Reports - Gas Measurement<br/>Billing (GMB)</b> | Standard Number:<br><b>GS 6400.140(CG)</b><br>P&P 724-14 |
| Supersedes:<br>N/A            |   | Page 4 of 12   |

EXHIBIT A  
(1 of 3)

| COLUMBIA GAS SYSTEM |                         | METER READING CARD |                  |                |                  |       | FIXED METERING<br>PRESSURE |         |      |
|---------------------|-------------------------|--------------------|------------------|----------------|------------------|-------|----------------------------|---------|------|
| STATION NAME        |                         |                    |                  |                |                  |       | PSIG                       |         |      |
| PLACED BY:          |                         |                    | REMOVED BY:      |                |                  |       |                            |         |      |
| CHART TYPE          | STATION ID NUMBER       |                    |                  |                | PLACED           |       |                            | REMOVED |      |
| 712                 | AREA ALPHA<br>ID PREFIX | STATION<br>NUMBER  | SEQ.             | MONTH          | DATE             | MONTH | DATE                       | MONTH   | DATE |
|                     |                         |                    |                  |                |                  |       |                            |         |      |
| 1                   | PERCENT ACCURACY        | SEQ.               | PERCENT ACCURACY | SEQ.           | PERCENT ACCURACY | SEQ.  | PERCENT ACCURACY           | SEQ.    | YEAR |
|                     |                         |                    |                  |                |                  |       |                            |         |      |
|                     | REMOVED READING         |                    | REMOVED READING  |                | REMOVED READING  |       | REMOVED READING            |         |      |
|                     | PLACED READING          |                    | PLACED READING   |                | PLACED READING   |       | PLACED READING             |         |      |
|                     | DIFFERENCE              |                    | DIFFERENCE       |                | DIFFERENCE       |       | DIFFERENCE                 |         |      |
| 2                   | TRACE LENGTH            |                    |                  | PRESSURE VALUE |                  |       |                            |         |      |
|                     |                         |                    |                  |                |                  |       |                            |         |      |
|                     |                         |                    |                  |                |                  |       |                            |         |      |

Front Side

|          |
|----------|
| REMARKS: |
|          |
|          |
|          |
|          |
|          |
|          |
|          |
|          |
|          |
|          |
|          |
|          |
|          |
|          |
|          |
|          |
|          |
|          |
|          |
|          |

Back Side

COLOR - PINK  
SIZE - 4" x 6" (As Shown)



Gas Standard

Distribution Operations

|                               |   |  |
|-------------------------------|---|--|
| Effective Date:<br>07/15/1981 | <b>Mailing of Meter Charts, Records<br/>and Reports - Gas Measurement<br/>Billing (GMB)</b> | Standard Number:<br><b>GS 6400.140(CG)</b><br>P&P 724-14 |
| Supersedes:<br>N/A            |   | Page 5 of 12   |

**EXHIBIT A  
(2 of 3)**

**CHART TYPE** GMB

**METER READ BY** GMB

**PERCENT ACCURACY** SEQ. 1

**ALL READINGS IN MCP** 1

**PERCENT ACCURACY** IN MCP 50

**PRESSURE COMP.** 50

**PRESSURE AND TEMP. COMP.** 60

**STATION NAME**

**STATION NUMBER**

**SEQ.**

**MONTH** **DAY** **HOUR** **MONTH** **DAY** **HOUR**

**YEAR** **M**

| CONTRACT BASE (PRESENT) |           | AT METERING PRESS./TEMP. |           | VELOC. INDEX |           |
|-------------------------|-----------|--------------------------|-----------|--------------|-----------|
| MILLIONS                | THOUSANDS | MILLIONS                 | THOUSANDS | MILLIONS     | THOUSANDS |
| PRESENT                 |           | PRESENT                  |           | PRESENT      |           |
| PREVIOUS                |           | PREVIOUS                 |           | PREVIOUS     |           |
| DIFFERENCE              |           | DIFFERENCE               |           | DIFFERENCE   |           |

| DISPLACEMENT METER READING RECORD |                  |
|-----------------------------------|------------------|
| PRESENT PRESS. PSIG               | STANDARD INDEX   |
| TEMPERATURE                       | AIR CONDITIONING |
| PRESENT                           | LOW PRESSURE     |
| PREVIOUS                          |                  |
| DIFFERENCE                        |                  |

FORM CG 6-178 CSD  
112-701

COLUMBIA GAS SYSTEM

SEE OTHER SIDE

Front Side

COLOR - YELLOW

SIZE - 5-1/2" x 8" (As Shown)



**Gas Standard**

Distribution Operations

|                               |   |  |
|-------------------------------|---|--|
| Effective Date:<br>07/15/1981 | <b>Mailing of Meter Charts, Records<br/>and Reports - Gas Measurement<br/>Billing (GMB)</b> | Standard Number:<br><b>GS 6400.140(CG)</b><br>P&P 724-14 |
| Supersedes:<br>N/A            |   | Page 6 of 12   |

**EXHIBIT A  
(3 of 3)**

**FOR USE IN DEVELOPING ESTIMATES BROUGHT ABOUT BY TESTS, BYPASSING, INSTRUMENT FAILURE, ETC.**

REAR INDEX REGISTRATION \_\_\_\_\_  
 VEEDER \_\_\_\_\_

FOR ESTIMATE \_\_\_\_\_ # AVG. PRESS. \_\_\_\_\_ PRESSURE MULTIPLIER FACTOR \_\_\_\_\_  
 (PRESSURE BASE \_\_\_\_\_ PSIA)  
 FOR ESTIMATE \_\_\_\_\_ °F. AVG. TEMP. \_\_\_\_\_ TEMPERATURE MULTIPLIER FACTOR \_\_\_\_\_  
 SUPERCOMPRESSIBILITY FACTOR \_\_\_\_\_

TOTAL ESTIMATE \_\_\_\_\_ MCF

| NO. 1 DETAIL: PERIOD |         | NO. 2 DETAIL: PERIOD |         | TO   |     |
|----------------------|---------|----------------------|---------|------|-----|
| EST                  | PERCENT | EST                  | PERCENT | DEAD | MCF |
| EXP                  |         | TST                  |         | FAST |     |
| ADJ                  |         | ADJ                  |         | SLOW |     |
|                      |         |                      |         | TEST |     |
|                      |         |                      |         | TEST |     |

REMARKS \_\_\_\_\_

APPROVED \_\_\_\_\_ SIGNED \_\_\_\_\_ DIVISION MEASUREMENT SUPERVISOR  
 APPROVED \_\_\_\_\_ SIGNED \_\_\_\_\_ INDUSTRIAL SALES REPRESENTATIVE  
 APPROVED \_\_\_\_\_ SIGNED \_\_\_\_\_ CUSTOMER REPRESENTATIVE

Back Side  
 COLOR - YELLOW  
 SIZE - 5-1/2" x 8" (As Shown)



Gas Standard

Distribution Operations

|                               |   |  |
|-------------------------------|---|--|
| Effective Date:<br>07/15/1981 | <b>Mailing of Meter Charts, Records<br/>and Reports - Gas Measurement<br/>Billing (GMB)</b> | Standard Number:<br><b>GS 6400.140(CG)</b><br>P&P 724-14 |
| Supersedes:<br>N/A            |   | Page 7 of 12   |

EXHIBIT B

FORM CG 6-2-3 (2-81) CSG COLUMBIA GAS SYSTEM  
**METERING EQUIPMENT CHANGE REPORT 35603**

STATION ID NO. \_\_\_\_\_ DATE \_\_\_\_\_ AREA ID.-ALPHA PREFIX-STAT.NO.-SEQ. \_\_\_\_\_

MEAS. GAS FROM \_\_\_\_\_  
MEAS. GAS TO \_\_\_\_\_ STATION NAME (IF APPLICABLE) \_\_\_\_\_

MUNICIPALITY, TWP. OR DIST. \_\_\_\_\_ COUNTY \_\_\_\_\_ STATE \_\_\_\_\_

TYPE OF CHANGE  INSTALLED  TURNED ON  REMOVED  TURNED OFF

TIME \_\_\_\_\_ HR. \_\_\_\_\_ MIN. \_\_\_\_\_ AM/PM \_\_\_\_\_ HR. \_\_\_\_\_ MIN. \_\_\_\_\_ AM/PM

ORIFICE PLATE SIZE \_\_\_\_\_ " X " \_\_\_\_\_ " X "

OTHER OTHER \_\_\_\_\_

OTHER METERS KIND, SIZE, WP. \_\_\_\_\_

SERIAL NUMBER \_\_\_\_\_

TYPE OF INDEX CIRCULAR DIAL  DIGITAL  CIRCULAR DIAL  DIGITAL

INDEX PROVING HAND \_\_\_\_\_ CU.FT./REV. \_\_\_\_\_ CU.FT./REV. \_\_\_\_\_

INTERMEDIATE GEAR RATIO (DIAPHRAGM METERS ONLY) \_\_\_\_\_ - 1 \_\_\_\_\_ - 1 \_\_\_\_\_

INDEX OR COUNTER READING (INCORRECTED) MILLIONS THOUSANDS MILLIONS THOUSANDS

INSTRUMENTS MFG. & TYPE \_\_\_\_\_

MODEL & SERIAL NO. \_\_\_\_\_

CHART NUMBER CGS# \_\_\_\_\_ CGS# \_\_\_\_\_

STATIC PRESSURE RANGE \_\_\_\_\_ PSIG \_\_\_\_\_ PSIG

DIFFERENTIAL PRESSURE RANGE \_\_\_\_\_ INCHES \_\_\_\_\_ INCHES

TEMPERATURE RANGE \_\_\_\_\_ OF \_\_\_\_\_ OF

CHART REV. OR SCALLOP MCF/SCAL REY  MCF/SCAL REY

CHART ROTATION; 24 HR 7 DAY, ETC. (CLOCKWISE) HR/DAY \_\_\_\_\_ HR/DAY \_\_\_\_\_

INTEGRATING INDEX READING (CORRECTED) MILLIONS THOUSANDS MILLIONS THOUSANDS

PRESS. BASE PSIA \_\_\_\_\_

METER STATUS AS LEFT ACTIVE  SOLOP

IF STATION NAME CHANGE SHOW FORMER NAME \_\_\_\_\_

REMARKS \_\_\_\_\_

SIGNED \_\_\_\_\_

INSTALLLED \_\_\_\_\_ DUPLICATE \_\_\_\_\_ REMOVED \_\_\_\_\_

COLOR - ORIGINAL - LIGHT BLUE  
DUPLICATE - LIGHT BLUE  
TRIPLICATE - LIGHT BLUE

SIZE - 6" x 8" (As Shown)



Distribution Operations

|                               |   |  |
|-------------------------------|---|--|
| Effective Date:<br>07/15/1981 | <b>Mailing of Meter Charts, Records and Reports - Gas Measurement Billing (GMB)</b> | Standard Number:<br><b>GS 6400.140(CG)</b><br>P&P 724-14 |
| Supersedes:<br>N/A            |   | Page 8 of 12   |

EXHIBIT C

FORM CS 6-9 CSO 19-80 COLUMBIA GAS SYSTEM  
**FIELD TOLERANCES FOR METERS AND METERING EQUIPMENT**

| DIAPHRAGM DISPLACEMENT, ROTARY & TURBINE METERS |  | WHERE THE FOLLOWING TOLERANCES ARE "EXCEEDED"   |  |
|---|--|---|--|
|   |  | ADJUST EQUIPMENT  | CHANGE CHART - Mark Test/Inspection Report "Out of Tolerance". Send Duplicate Copy of Report to "Chart Processing Office". |
| Provee  | Diaphragm Meters (I) (C)<br>a. Meter Accuracy at any test rate<br>b. Max spread between test rates     | 100% ± 2.0%<br>2.0%<br>± 1.0% (15% min. test rate)                                    | ± 2.0% of any test rate<br>-----<br>± 2.0% at any test rate  |
| Test  | Rotary & Turbine Meters  |   |  |
|   | Rotary Meter Differential Tests  | 50% in excess of differential curve established at time of installation.              |  |
|   | Turbine Meter Spin Tests   | Spin time lower than manufacturer's published minimum (Refer to M & R Field Handbook) |  |
| Pressure Recorders                              | a. At Zero<br>b. At Operating Pressure<br>c. At Other Points   | ± 2.0% of Element Range<br>ZERO<br>± 2.0% of Element Range                            | ± 2.0% of Test Instrument Reading<br>-----<br>-----  |
| Integrating Indicia                             | Pressure Element<br>a. At Operating Pressure<br>b. At Intermediate Points<br>c. 0.10% of Element Range | ± 1.0% of Required Value<br>± 1.0% of Required Value<br>± 2.0% of Required Value      | ± 2.0% of Required Value at Operating Pressure and/or Temperature  |
| Temperature Recorders                           | Temperature Element<br>a. At Operating Temperature   | ± 1.0% of Required Value  | Note: No Chart Involved, Test Report Only  |
|   | Fluid Accumulation in Diaphragm Meters   | Drain & Report Amount Drained   | 4 Qts. or more   |

(1) More stringent tolerances are required for CDC meters in New York, Kentucky, and Maryland (Refer to State Rules).  
(2) In most instances diaphragm meter proofs can be adjusted within ± 1.0% and can be held to a max tolerance of 1.5% spread between flows. Where practical these more stringent tolerances are recommended.  
NOTE: Tolerances on entire card will be in effect except where regulatory body or contract tolerances are more stringent. In such instances the more stringent tolerances shall supersede.

Front Side

FORM CS 6-9 CSO 19-80 COLUMBIA GAS SYSTEM  
**FIELD TOLERANCES FOR METERS AND METERING EQUIPMENT**

| ORIFICE METERS        |   | WHERE THE FOLLOWING TOLERANCES ARE "EXCEEDED"   |  |
|-----------------------|---|---|--|
|                       |   | ADJUST EQUIPMENT  | CHANGE CHART - Mark Test/Inspection Report "Out of Tolerance". Send Duplicate Copy of Report to "Chart Processing Office". |
| Differential Gauge    | a. Zero Test (Under Pressure)<br>b. Calibration—Full Scale  | ZERO<br>± 1% of Manometer reading, but not less than either:<br>(a) 0.1" Water Column when using a Water Manometer or PW Tester<br>(b) 0.2" Water Column when using a Mercury Manometer | ± 0.3" WC<br>± 1% of Test Instrument reading, but not less than ± 0.3" Water Column  |
| Static Element        | a. At Zero<br>b. At Operating Pressure<br>c. At Other Points  | ± 2.0% of Element Range<br>ZERO<br>± 2.0% of Test Instrument Reading  | ± 2.0% of Test Instrument Reading  |
| Gauge Line Leakage    | a. Differential Change<br>b. Static Pressure Change   | 6" Water Column per minute<br>1% of Element Range per minute III  | -----  |
| Temperature Recorders | a. At Operating Temperature   | ± 1.0% of Element Range   | ± 3.0°F  |
| Gravimeters           | a. On Predetermined Sample or Test Instrument (Banana, Kimmey, or Other)<br>NOTE: Complete calibration required when an adjustment greater than .012 is required to bring it in agreement with the known specific gravity or where two consecutive adjustments of the beam weight are made in the same direction. | ± .005  | ± .007   |
| Calorimeters          | a. Mechanical Balance (Old AB style)<br>b. Cold Balance<br>c. Predetermined Gas Sample  | ZERO<br>ZERO<br>3 Btu   | -----<br>-----<br>10 Btu when used for billing   |

(1) If practical, all gauge line leakage shall be eliminated.  
NOTE: Tolerances on entire card will be in effect except where regulatory body or contract tolerances are more stringent. In such instances, the more stringent tolerances shall supersede.

Back Side

Color - Yellow Plastisized Card  
Size - 3-1/2" x 5-1/2" (As Shown)

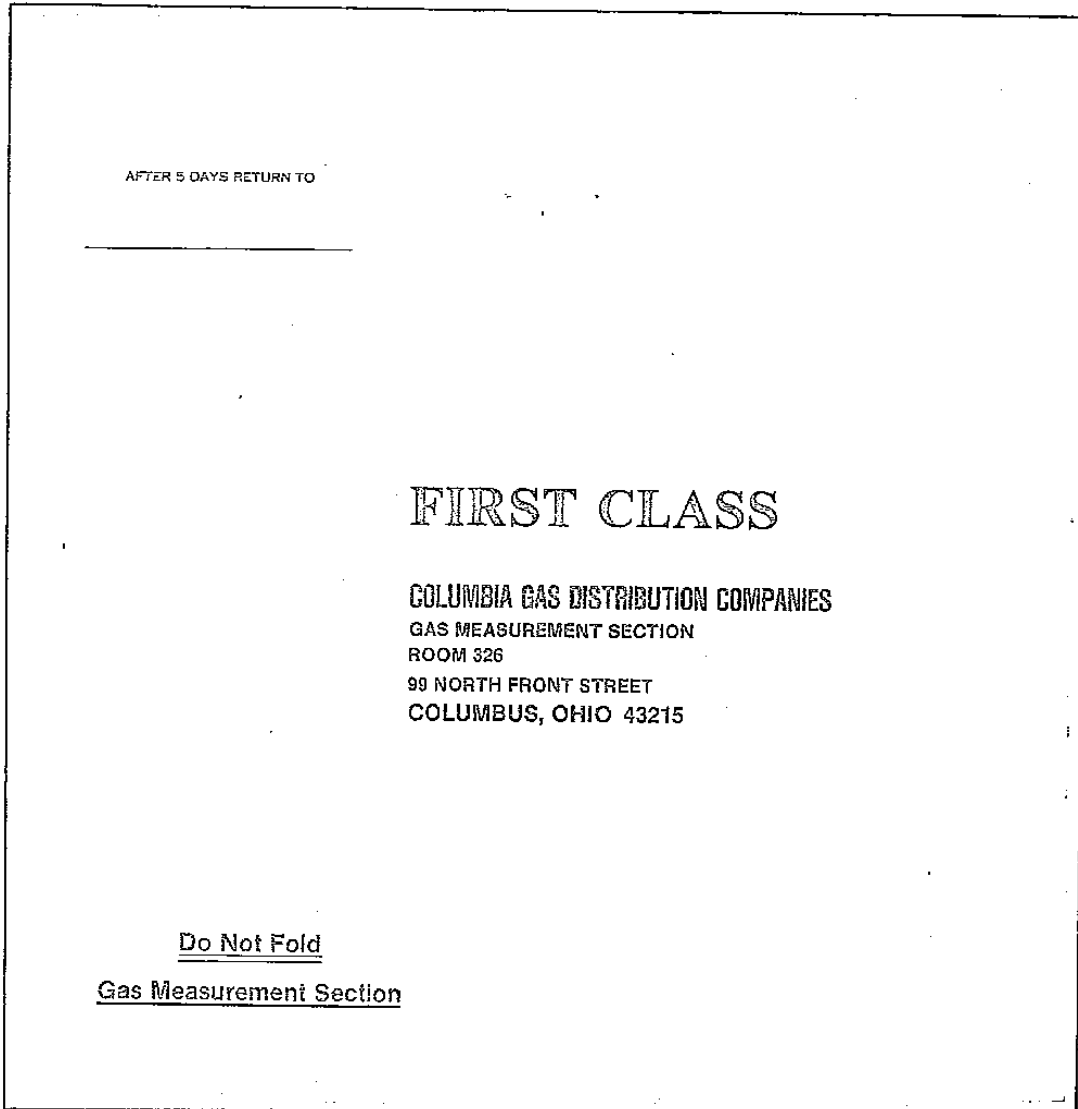


**Gas Standard**

Distribution Operations

|                               |   |  |
|-------------------------------|---|--|
| Effective Date:<br>07/15/1981 | <b>Mailing of Meter Charts, Records<br/>and Reports - Gas Measurement<br/>Billing (GMB)</b> | Standard Number:<br><b>GS 6400.140(CG)</b><br>P&P 724-14 |
| Supersedes:<br>N/A            |   | Page 9 of 12   |

**EXHIBIT D**



DESCRIPTION: COLUMBIA GAS DISTRIBUTION COMPANIES  
CHART ENVELOPES  
FORM C 540-1  
SIZE 12" x 12"  
COLOR MANILA

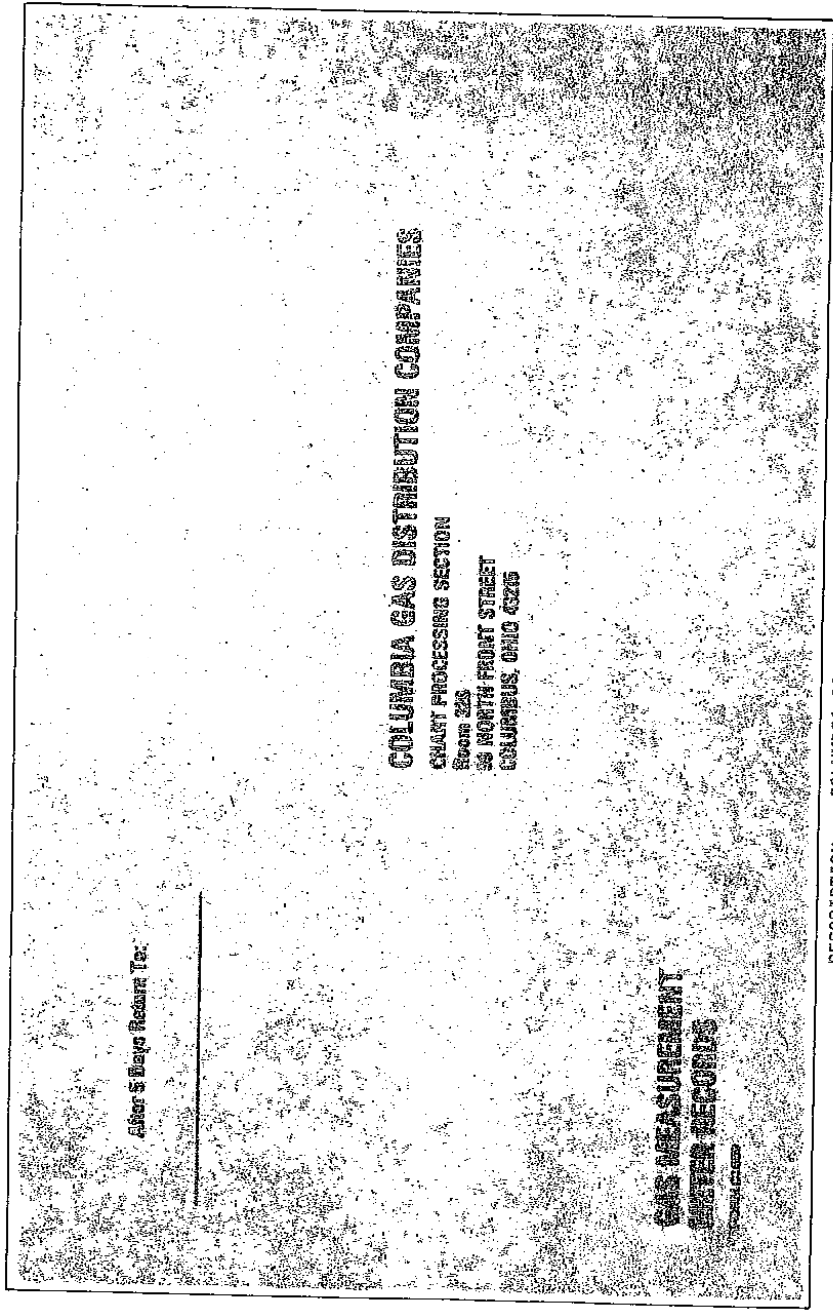


**Gas Standard**

Distribution Operations

|                               |   |  |
|-------------------------------|---|--|
| Effective Date:<br>07/15/1981 | <b>Mailing of Meter Charts, Records<br/>and Reports - Gas Measurement<br/>Billing (GMB)</b> | Standard Number:<br><b>GS 6400.140(CG)</b><br>P&P 724-14 |
| Supersedes:<br>N/A            |   | Page 10 of 12  |

**EXHIBIT E**



DESCRIPTION: COLUMBIA GAS DISTRIBUTION COMPANIES  
METER RECORD ENVELOPE  
FORM C 1859  
SIZE 6" x 9-1/2"  
COLOR MARILLA

After 5 Days Return To:

**GAS MEASUREMENT  
METER RECORDS**

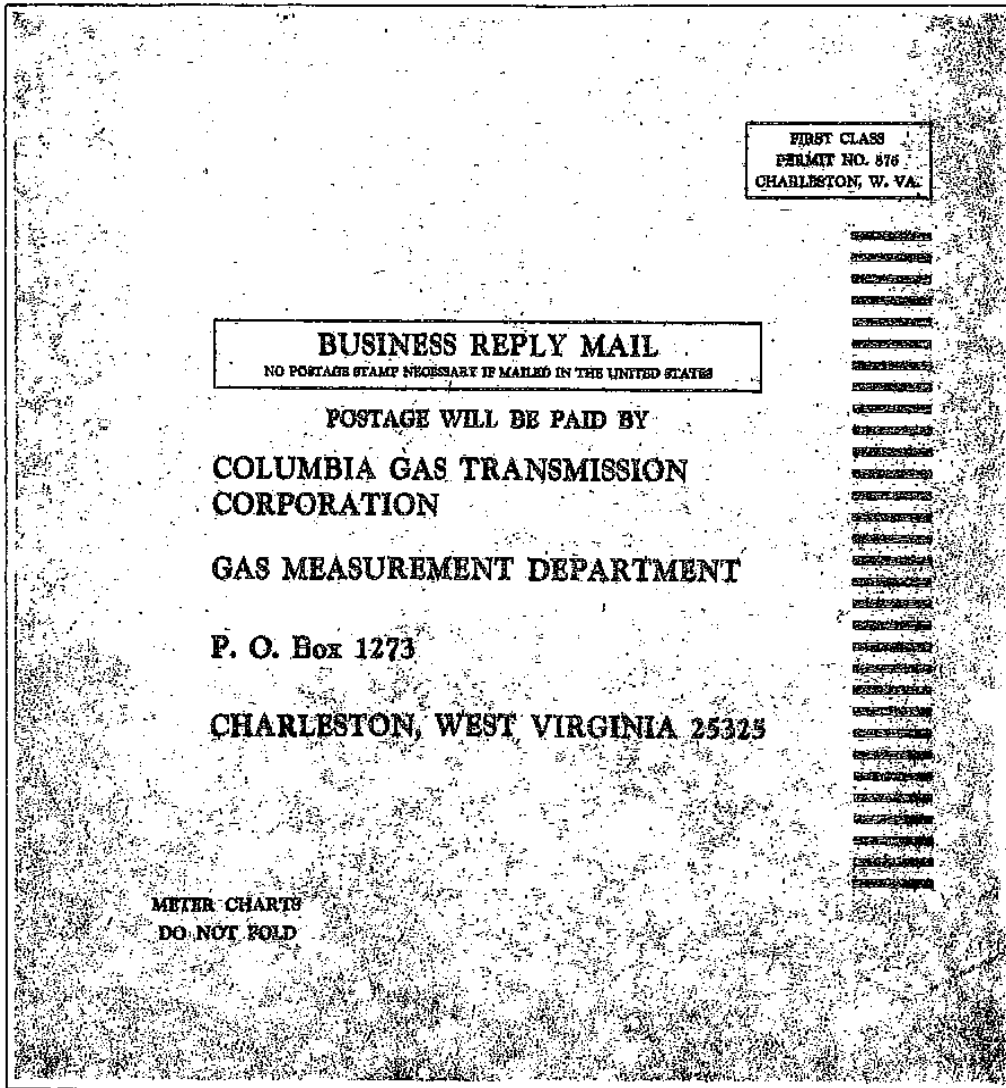


Gas Standard

Distribution Operations

|                               |   |  |
|-------------------------------|---|--|
| Effective Date:<br>07/15/1981 | <b>Mailing of Meter Charts, Records<br/>and Reports - Gas Measurement<br/>Billing (GMB)</b> | Standard Number:<br><b>GS 6400.140(CG)</b><br>P&P 724-14 |
| Supersedes:<br>N/A            |   | Page 11 of 12  |

EXHIBIT F



DESCRIPTION: COLUMBIA GAS TRANSMISSION CORPORATION  
CHART ENVELOPES  
SIZE 12-1/4" x 12-1/4"  
COLOR MANILLA



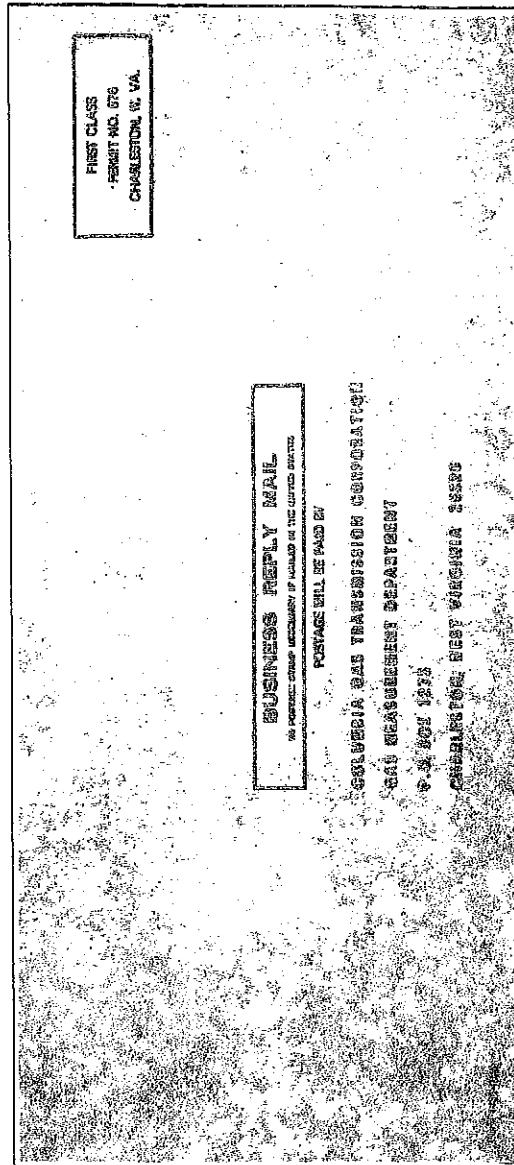


**Gas Standard**

Distribution Operations

|                               |   |  |
|-------------------------------|---|--|
| Effective Date:<br>07/15/1981 | <b>Mailing of Meter Charts, Records<br/>and Reports - Gas Measurement<br/>Billing (GMB)</b> | Standard Number:<br><b>GS 6400.140(CG)</b><br>P&P 724-14 |
| Supersedes:<br>N/A            |   | Page 12 of 12  |

**EXHIBIT G**



DESCRIPTION: COLUMBIA GAS TRANSMISSION CORPORATION  
METER RECORD ENVELOPE  
FORM 1409-GMS  
SIZE 5" x 11-1/2"  
COLOR MANILLA



Distribution Operations

|                               |   |  |
|-------------------------------|---|--|
| Effective Date:<br>07/16/1980 | <b>Estimating and Reporting<br/>Bypassed Gas and Index Build-up</b> | Standard Number:<br><b>GS 6400.150(CG)</b><br>P&P 724-15 |
| Supersedes:<br>N/A            |   | Page 1 of 17   |

Companies Affected:

|                                     |   |   |
|-------------------------------------|---|---|
| <input type="checkbox"/> NIPSCO     | <input checked="" type="checkbox"/> CGV | <input checked="" type="checkbox"/> CMD |
| <input type="checkbox"/> NIFL       | <input checked="" type="checkbox"/> CKY | <input checked="" type="checkbox"/> COH |
| <input type="checkbox"/> Kokomo Gas | <input type="checkbox"/> CMA            | <input checked="" type="checkbox"/> CPA |

**REFERENCE**    None

**1. GENERAL REQUIREMENTS**

While the purpose of this procedure is primarily to outline methods for estimating bypassed gas, index build-up, etc., incorrect or lost registration should be reported in the same manner with a full explanation of the as-found condition, how corrected, and, if possible, whom to contact for an estimate verification.

Four forms are used to record information when meters are tested. These forms: CS 6-183, "Meter Test (as Found Transfer Prover);" CS 6-21, "Meter Test Report (As Found - Orifice Prover);" CS 6-23, "Integrating Index Test Report" and CS 6-16, "Orifice Meter Test Report (as Found)." Through-out the Policy and Procedure these forms will be referred to as Test Report. Copies of the Test Reports are included in Exhibit B. Completed examples of the Test Reports are included in Exhibit C.

When a chart or a copy of a Test Report indicating bypassed gas or index build-up is sent to the Finance, Gas Measurement Section for pro-cessing, the original of the Test Report sent to the District or Division Service Supervisor shall be noted "CSGM" (Copy Sent To Gas Measurement) or "C&CSGM" (Chart and Copy Sent To Gas Measurement).

There may be occasions when it is advisable to have a large estimate verified by the local Industrial Engineer or Gas Utilization Representative.

The bypassing of a measuring station shall be done in accordance with [GS 6400.180\(CG\)](#) "Bypassing of Measuring Stations."

**2. DETERMINING WHEN A GAS ESTIMATE IS REQUIRED**

**2.1 Conditions When an Estimate is Required**

- a. If, during the testing, inspection or repairing of a diaphragm, rotary or turbine meter or associated instrumentation, the bypassed gas or index

*This document is considered CONTROLLED only when viewed electronically on the Company's intranet. Printed or other electronic copies may not be current, and the intranet version should be used to verify.*



Distribution Operations

|                               |   |  |
|-------------------------------|---|--|
| Effective Date:<br>07/16/1980 | <b>Estimating and Reporting<br/>Bypassed Gas and Index Build-up</b> | Standard Number:<br><b>GS 6400.150(CG)</b><br>P&P 724-15 |
| Supersedes:<br>N/A            |   | Page 2 of 17   |

build-up would result in a billing adjustment in excess of one Mscf (one thousand standard cubic feet).

- b. If an orifice meter is bypassed or the orifice gauge is taken out of service.

**2.2 Conditions when an Estimate is not Required**

- a. If the station can be taken out of service.
- b. If the delivery can be measured within prescribed minimum and maximum rates of flow through parallel meter(s).

**3. METHODS OF ESTIMATING BYPASSED GAS FOR DIAPHRAGM, ROTARY AND TURBINE METERS**

Estimates of bypassed gas for diaphragm, rotary and turbine meters shall be shown in the Remarks section of the Test Report form as an uncorrected volume for an indicated time period. The estimated bypassed gas, as determined from the “before test” and “after test” flow data taking into account any unusual flow conditions, shall be stated in the following manner (See Exhibit C, Examples 2, 4a., & b., and 5).

Estimate \_\_\_\_ cu. ft. (uncorrected) at \_\_\_\_  
psig. and \_\_\_\_ OF. bypassed from \_\_\_\_ a.m./p.m.  
\_\_\_\_ a.m./p.m.

**3.1 Single or Multiple Meters with All Gas Bypassed**

- a. Determine hourly index rate(s) of flow through the meter(s) under the normal operating mode of station.
- b. Record the “before test” index reading(s), hourly index rate(s), static pressure and flowing temperature (if available) on Test Report.
- c. Place the station on bypass and record the time at which the bypass was opened, then proceed with planned work.
- d. After work is completed and station is back in service, record the time at which the bypass was closed.
- e. Determine the hourly index rate(s) of flow through the meter(s) under normal operating mode of station.
- f. Record “after test” index reading(s), hourly index rate(s), static pressure and flowing temperature (if available) on Test Report.



Distribution Operations

|                               |  |  |
|-------------------------------|--|--|
| Effective Date:<br>07/16/1980 | <h2 style="margin: 0;">Estimating and Reporting<br/>Bypassed Gas and Index Build-up</h2> | Standard Number:<br><b>GS 6400.150(CG)</b><br>P&P 724-15 |
| Supersedes:<br>N/A            |  | Page 3 of 17   |

- g. Record estimate of bypassed gas on Test Report.

**3.2 Multiple Meters with a Portion of the Gas Bypassed**

This type of bypassing operation is usually encountered at the larger measuring stations where the meters are operating near maximum capacity. The two methods presented cover steady and varying load conditions. Both procedures should only be used by an experienced measurement person or under the direction of a super-visor because of the difficulty in performing the bypassing operation and in estimating bypassed gas.

**3.2.1 Steady Load**

- a. Determine the hourly index rate of flow through each meter with bypass closed and note on scratch paper.
- b. Record the “before test” index reading, hourly index rate, static pressure and flowing temperature (if avail-able) of meter to be tested (or repaired) on Test Report.
- c. Open the bypass, shut off meter to be tested, and note the time on scratch paper. Then partially close bypass to the point that each remaining meter is operating at approximately the same rate as it was when all meters where in service. Note the hourly index rate of each meter on scratch paper.
- d. After the test is completed and bypass closed, note the time on scratch paper. Then determine the hourly index rate on each meter and note on scratch paper. A comparison of the “before test” and “after test” index rates should verify a steady load condition.
- e. Record the “after test” index reading, hourly index rate, static pressure and flowing temperature (if avail-able) of meter tested on Test Report.
- f. Record on Test Report the estimate of bypassed gas for the meter tested.

**3.2.2 Varying Load - Ratio Method**

- g. Perform steps (1) through (5) as shown in 3.2.1.
- h. Determine the amount of gas registered on the meter or meters remaining in service by subtracting the “before test” from the “after



Distribution Operations

|                               |  |  |
|-------------------------------|--|--|
| Effective Date:<br>07/16/1980 | <h2 style="margin: 0;">Estimating and Reporting<br/>Bypassed Gas and Index Build-up</h2> | Standard Number:<br><b>GS 6400.150(CG)</b><br>P&P 724-15 |
| Supersedes:<br>N/A            |  | Page 4 of 17   |

test” bypassed gas index readings. Add the registration if more than one meter remained in service.

- i. Establish ratio of gas hourly index rate bypassed to gas hourly index rate measured through meter or meters left in service during test by comparing rate from steps (1) through (3) in 3.2.1. Divide hourly index rate through bypass by the total of the hourly index rates of the meters left in service.
- j. Multiply the ratio obtained in step (3) by the total index registration of meter or meters left in service to obtain estimate of gas bypassed during test. Record bypassed gas on Test Report.

**3.3 Integrating Instruments**

Inspecting, testing, calibrating or repairing integrating instruments, i.e., BPI, BVI, BPI - CI, Mercor III, Emcorector, Temcorector, etc., do not usually require that the meter be taken out of service.

Depending on the type of instrument and the nature of the work being performed, the uncorrected counter may or may not remain in service. When the uncorrected counter is disengaged or out of service during a particular work function, the gas shall be considered as bypassed. This bypassed gas must be accounted for in essentially the same manner as when a meter is bypassed.

To avoid the possibility of double billing, be explicit in reporting uncorrected registration or bypassed gas at meters using integrating indexes. For example, show a bypassed gas estimate on either the Integrating Index Test Report or the Meter Test Report with a cross reference if one estimate is for both the instrument test and the meter test. If a test on a meter and an integrating index require a separate bypassing operation, include a bypassed gas estimate on each Test Report. The bypassing time periods should verify them as a separate bypassing operation. In each case send both Test Reports, stapled together, to the Gas Measurement Section.

Since different techniques are required to test the various integrating instruments, the following instructions shall be used to properly account for any possible lost registration.

**3.3.1 Corrected Counter Disengaged, Uncorrected Counter Engaged**

- k. When the uncorrected counter or index remains engaged and registers all the flow during the test, report “before test” and “after



Distribution Operations

|                               |   |  |
|-------------------------------|---|--|
| Effective Date:<br>07/16/1980 | <b>Estimating and Reporting<br/>Bypassed Gas and Index Build-up</b> | Standard Number:<br><b>GS 6400.150(CG)</b><br>P&P 724-15 |
| Supersedes:<br>N/A            |   | Page 5 of 17   |

test" index readings, hourly index rates, registration during test, pressure and temperature (if avail-able) in the appropriate blocks on the Test Report. No remarks are necessary. (See Exhibit C, Example 6 and 7.)

- I. Engage the corrected counter at completion of. Test at same reading as when taken out of service. Do not manually advance this counter to account for bypassed registration.

**3.3.2 Both Corrected and Uncorrected Counters Disengaged**

- m. Record "before test" and "after Test" index readings, hourly index rates, etc., in the appropriate blocks on the Test Report. Under the Remarks section, estimate bypassed gas in the same manner as if the meter had been bypassed.
- n. Return instrument to service with both the corrected and uncorrected counters or index set at the same reading as when removed from service.

**3.3.3 Corrected and Uncorrected Counters Engaged and Instruments Not Taken Out of Service**

When the instrument is tested at the operating pressure and/or temperature while remaining in service, with both corrected and uncorrected counters engaged, no adjustment is required. A notation in the Remarks section of the Test Report should state, Instrument tested while in continuous service, no adjustment required.

**4. METHODS OF REPORTING BYPASSED GAS AND INDEX BUILD-UP**

**4.1 Station Out of Service or Gas Measured by Parallel Meter(s)**

- c. Test Report and chart should be noted as to action taken; i.e., Station out of service, \_\_\_\_ a.m./p.m. to \_\_\_\_ a.m./p.m., no gas bypassed or, All gas measured by parallel meter(s) \_\_\_\_ a.m./p.m. to \_\_\_\_ a.m./p.m.
- d. Do not send a copy of the Test Report to the Gas Measurement Section unless the equipment is found out of tolerance.



Distribution Operations

|                               |   |  |
|-------------------------------|---|--|
| Effective Date:<br>07/16/1980 | <b>Estimating and Reporting<br/>Bypassed Gas and Index Build-up</b> | Standard Number:<br><b>GS 6400.150(CG)</b><br>P&P 724-15 |
| Supersedes:<br>N/A            |   | Page 6 of 17   |

**4.2 Meter and/or Recording Instrument Found Within Tolerance; Bypassed Gas or Index Build-up Less Than One Mscf**

- e. Note under Remarks on back of chart, meter and/or gauge test, no billing adjustment, date and initial. Do not change chart.
- f. Do not send a copy of the Test Report to the Gas Measurement Section.

**4.3 Meter and/or Recording Instrument Found Out of Tolerance**

- g. Remove chart and note under Remarks, meter and/or gauge out of tolerance, see Test Report, date and initial.
- h. Send chart and copy of Test Report to the Gas Measurement Section.

**4.4 Meter and/or Recording Instrument Found Within Tolerance; the Combined Net Result of Bypassed Gas and Index Build-up Less Than One Mscf**

- i. Note under Remarks on chart, meter and/or gauge test, no billing adjustment, date and initial. Do not change chart.
- j. Do not send a copy of the Test Report to the Gas Measurement Section.

**4.5 Meter and/or Recording Instrument where the Combined Net Result of Bypassed Gas and Index Build-up is in Excess of One Mscf**

- k. Note under Remarks on chart, meter and/or gauge test, see Test Report, date and initial. Do not change chart.
- l. Send a copy of the Test Report to the Gas Measurement Section.

**4.6 Meters where no Charts are Used (Meters with Integrating Indexes or Meters with Standard Indexes Billed by the Gas Measurement Section)**

Show all applicable comments as explained in 4.1 through 4.5 above under Remarks on the Test Report and, when required, forward a copy of the Test Report to the Gas Measurement Section.

**5. REPORTING INFORMATION FOR BYPASSED ORIFICE METERS**

If it becomes necessary to estimate the gas bypassed as a result of taking an orifice meter or gauge out of service, indicate the following information under the Remarks Section on the back printing of the Recording Chart and also on Form CS 6-16, Orifice Meter Test Report (As Found).



Distribution Operations

|                               |   |  |
|-------------------------------|---|--|
| Effective Date:<br>07/16/1980 | <b>Estimating and Reporting<br/>Bypassed Gas and Index Build-up</b> | Standard Number:<br><b>GS 6400.150(CG)</b><br>P&P 724-15 |
| Supersedes:<br>N/A            |   | Page 7 of 17   |

- a. Whether the orifice meter was bypassed or the gauge taken out of service.
- b. Date and time for which estimate will be required.
- c. Whether estimate is to be made as if orifice meter were in continuous service or whether all bypassed gas was measured by parallel meter(s).

Send a copy of the Test Report to the Gas Measurement Section. Only send the chart to the Gas Measurement Section if the orifice (primary element or secondary element) meter was found out of tolerance.





Distribution Operations

|                               |   |  |
|-------------------------------|---|--|
| Effective Date:<br>07/16/1980 | <b>Estimating and Reporting<br/>Bypassed Gas and Index Build-up</b> | Standard Number:<br><b>GS 6400.150(CG)</b><br>P&P 724-15 |
| Supersedes:<br>N/A            |   | Page 8 of 17   |

**EXHIBIT A**

EXAMPLE OF  
RATIO METHOD OF ESTIMATING BYPASSED GAS

Statement of Conditions and Work to be Performed:

A measurement station has a 16M Roots and a 38M Roots meter installed. It is necessary to make repairs to the 38M Roots meter. The gas delivery through the station varies and the delivery through the 38M Roots is such that it cannot be diverted through the 16M Roots meter. It is necessary to open the bypass and estimate the bypassed gas for six hours; the time required to make the repair.

Estimation of Bypassed Gas:

|  | Meter Kind |            | Total         |                 |        |        |
|--|------------|------------|---------------|-----------------|--------|--------|
|  | <u>16M</u> | <u>38M</u> | <u>Bypass</u> | <u>Delivery</u> |        |        |
| Hourly index rate (before bypassing), cfh      |            |            | 7,600         | 17,500          | x      | 25,100 |
| Hourly index rate (at initial (bypassing), cfh |            |            | 8,000         | 0               | 17,100 | 25,100 |
| Hourly index rate (during bypassing), cfh      |            |            | Varies        | 0               | Varies | Varies |
| Hourly index rate (after bypassing), cfh       |            |            | 12,000        | 25,650          |        | 37,650 |
| Index reading (after-test), Mcf                |            |            | 36,272        | 34,280          |        |        |
| Index reading (before-test), Mcf               |            |            | 36,200        | 34,280          |        |        |
| Registration during test, Mcf                  |            |            | 72            | 0               |        |        |

Estimated bypassed gas =Ratio of bypassed gas hourly index rate to 16M hourly index rate times 16M registration during test.

$$= \frac{17,100}{8,000} \times 72,000$$

= 153.8 Mcf uncorrected gas

See Exhibit C, Example 5.



Distribution Operations

|                               |   |  |
|-------------------------------|---|--|
| Effective Date:<br>07/16/1980 | <b>Estimating and Reporting<br/>Bypassed Gas and Index Build-up</b> | Standard Number:<br><b>GS 6400.150(CG)</b><br>P&P 724-15 |
| Supersedes:<br>N/A            |   | Page 9 of 17   |

**EXHIBIT B  
(1 of 4)**

FORM GS-100 (REV. 12-72) COLUMBIA GAS SYSTEM  
**METER TEST REPORT (AS FOUND) - TRANSFER PROVER**

|   |                     |                           |                                  |
|---|---------------------|---------------------------|----------------------------------|
| STATION NAME _____  |                     | TIME _____ A.M. / P.M.    |                                  |
| Prover Size and Manufacturer _____  |                     | CARD TYPE 1               |                                  |
| Serial No. _____  | Voltage O. C. _____ | Date: _____               |                                  |
| Transfer Mtr. Diff. Req'd _____ in.   | Actual _____ in.    | Station No. _____         | MONTH _____ DAY _____ YEAR _____ |
| Test Cycle Count Req'd _____  | Actual _____        | Index Reading (NCF) _____ | Inspection or Test Code _____    |
| <b>TEST NUMBER</b> →  | <b>1</b>            | <b>2</b>                  | <b>3</b>                         |
| Flare Range Selector  | ADR                 |                           |                                  |
| Coast Selector or Field Panel   | ADR                 |                           |                                  |
| Power Panel   | AD                  |                           |                                  |
| Base Count Req'd  | R                   |                           |                                  |
| Unadjusted Count Reading  | R                   |                           |                                  |
| Unadjusted Accuracy or Preset %   | DR                  |                           |                                  |
| Pressure Correction %   | DR                  |                           |                                  |
| Temp. Correction %  | DR                  |                           |                                  |
| Power Correction %  | R                   |                           |                                  |
| Adjusted Preset %   | AD                  |                           |                                  |
| Final Accuracy %  | ADR                 |                           |                                  |
| Air Flow Rate CFH   | ADR                 |                           |                                  |
| Equal Gas Flow Rate CFH   | ADR                 |                           |                                  |
| Piping Leakage Inspection Code _____<br>Strainer Inspection Code _____<br>As Found _____<br>As Left _____<br>Repair Code _____  |                     |                           |                                  |
| Meter Kind and Size _____<br>Read Last Prover Test _____ M<br>Amt. Registered _____ M<br>Date Last Prover Test _____ 19____<br>Reduced Capacity _____ CFH<br>Present Rate _____ CFH<br>Meter Capacity _____ CFH<br>Working Pressure _____ PSI<br>Rotary Meter Diff.: Act. _____ in. Req'd _____ in.<br>Counter Reading _____ M<br>Oil Level _____ Checked <input type="checkbox"/> Changed <input type="checkbox"/> |                     |                           |                                  |
| LEGEND: A - AMERICAN; D - DRESSER; R - ROCKWELL<br>REG. ON SLOW MOTION TEST YES <input type="checkbox"/> NO <input type="checkbox"/><br>CHARTS _____<br>Coast Rev. or Cycle _____<br>Chert Number _____<br>Range Press. _____ Temp. _____ °F  |                     |                           |                                  |
| FOUND CONDITIONS: VALVES _____ DIAPHRAGM _____<br>REMARKS: *(EXPLAIN) _____<br>Witnessed By _____ Test By _____<br>ORIGINAL   |                     |                           |                                  |

| GAS PASSED DURING TEST | CORRECTED |           | UNCORRECTED |           | TEMP. FLOW | PRESS. IN. OZ. LBS. | HOURLY RATE |
|------------------------|-----------|-----------|-------------|-----------|------------|---------------------|-------------|
|                        | MILLIONS  | THOUSANDS | MILLIONS    | THOUSANDS |            |                     |             |
| Index (After Test)     |           |           |             |           |            |                     |             |
| Index (Before Test)    |           |           |             |           |            |                     |             |
| Reg. During Test       |           |           |             |           |            |                     |             |

COLOR - ORIGINAL - GREEN  
DUPLICATE - GREEN  
TRIPLICATE - GREEN



Distribution Operations

|                               |   |  |
|-------------------------------|---|--|
| Effective Date:<br>07/16/1980 | <b>Estimating and Reporting<br/>Bypassed Gas and Index Build-up</b> | Standard Number:<br><b>GS 6400.150(CG)</b><br>P&P 724-15 |
| Supersedes:<br>N/A            |   | Page 10 of 17  |

**EXHIBIT B  
(2 of 4)**

FORM CS-21 CSD (3-72) COLUMBIA GAS SYSTEM  
**METER TEST REPORT (AS FOUND) - ORIFICE PROVER**

STATION NAME: \_\_\_\_\_ TIME: \_\_\_\_\_ A.M. / P.M.

|   |  |
|---|--|
| BAT-Orifice Size: PCV<br>Cu. Ft. Run: PCV<br>Ambient Temp. °F: PV<br>Relative Humidity %: PV<br>Specific Gravity: PCV<br>Prover Diff. (P <sub>1</sub> -P <sub>2</sub> ) "H <sub>2</sub> O: PV<br>Meter Press. (P <sub>3</sub> ) "H <sub>2</sub> O: PCV<br>Prover Press. (P <sub>1</sub> ) "H <sub>2</sub> O: PCV<br>Press. Diff. (Mtr. & Prover): PV<br>Prover Press. (P <sub>2</sub> ) "H <sub>2</sub> O: V<br>Barometer "Hg: PV<br>Prover Press. (P <sub>2</sub> ) "Hg: V<br>Abs. Press. (Bar.-P <sub>2</sub> ) "Hg: V<br>Meter Temp. °F: PCV<br>Prover Temp. °F (Tp): PCV<br>Temp. Diff. (Mtr. & Prover): PV<br>Table Time (See Book): PCV<br>Flow Temp. Corr. (sec): PV<br>Gravity Corr. (sec): PV<br>Required Time (sec): PCV<br>Watch Time (sec): PCV<br>Time Diff. (Watch & Req'd): PCV<br>Unadjusted Accuracy %: PCV<br>Press. Diff. Adj. %: PV<br>Temp. Diff. Adj. %: PCV<br>Super Adj. %: C<br>Final Accuracy %: PCV<br>Index Rate: PCV<br>L.P. Index Rate (Gas): PCV | CARD TYPE 1<br>Date: MONTH DAY YEAR<br>Station No. _____ SEQ. _____<br>Index Reading (MCF) _____<br>Inspection or Test Code _____<br>Piping Leakage Inspection Code _____<br>Strainer Inspection Code _____<br>AS FOUND: 10% 50% 100%<br>AS LEFT: _____<br>Repair Code _____<br>Meter Kind and Size _____<br>Read Last Prover Test _____ M<br>Amt. Registered _____ M<br>Date Last Prover Test _____ 19____<br>Reduced Capacity _____ CFH<br>Present Rate _____ CFH<br>Meter Capacity _____ CFH<br>Working Pressure _____ PSI<br>Rotary Meter Diff. Act. _____ in. Req'd _____ in.<br>Counter Reading _____ M<br>Oil Level Checked <input type="checkbox"/> Changed <input type="checkbox"/><br>REG. ON SLOW MOTION TEST YES <input type="checkbox"/> *NO <input type="checkbox"/><br>TEST GAGES _____<br>Test Gage Press. _____ In. Oz. Lbs.<br>Recorder _____<br>Test Thermometer _____ °F<br>Recorder _____<br>By-pass Valve <input type="checkbox"/> Seal. <input type="checkbox"/> Oper. <input type="checkbox"/> None <input type="checkbox"/> |
|---|--|

LEGEND: (P-Pressure V-Vacuum) Flange Tap. C-Critical Orifice Prover

Chart Rev. or Cycle \_\_\_\_\_  
Chart Number \_\_\_\_\_  
Range Press. \_\_\_\_\_ Temp. \_\_\_\_\_ °F

|                     | CORRECTED |           | UNCORRECTED |           | TEMP FLOW | PRESS. IN. OZ. LBS. | HOURLY RATE |
|---------------------|-----------|-----------|-------------|-----------|-----------|---------------------|-------------|
|                     | MILLIONS  | THOUSANDS | MILLIONS    | THOUSANDS |           |                     |             |
| Index (After Test)  |           |           |             |           |           |                     |             |
| Index (Before Test) |           |           |             |           |           |                     |             |
| Reg. During Test    |           |           |             |           |           |                     |             |

FOUND CONDITIONS: VALVES \_\_\_\_\_ DIAPHRAGM \_\_\_\_\_  
REMARKS: \*(EXPLAIN) \_\_\_\_\_  
Witnessed By \_\_\_\_\_ Test By \_\_\_\_\_  
ORIGINAL

COLOR - ORIGINAL - PINK  
DUPLICATE - PINK  
TRIPLICATE - PINK



**Gas Standard**

Distribution Operations

|                               |   |  |
|-------------------------------|---|--|
| Effective Date:<br>07/16/1980 | <b>Estimating and Reporting<br/>Bypassed Gas and Index Build-up</b> | Standard Number:<br><b>GS 6400.150(CG)</b><br>P&P 724-15 |
| Supersedes:<br>N/A            |   | Page 11 of 17  |

**EXHIBIT B  
(3 of 4)**

FORM CG 6-23 CSD  
(1-79)

COLUMBIA GAS SYSTEM  
**INTEGRATING INDEX TEST REPORT**

STATION NAME \_\_\_\_\_ TIME: \_\_\_\_\_ A.M.  
P.M.

|                           |                          |                           |                      |             |           |            |
|---------------------------|--------------------------|---------------------------|----------------------|-------------|-----------|------------|
| <b>INDEX</b>              |                          | INDEX NO. _____           | DATE _____           | MONTH _____ | DAY _____ | YEAR _____ |
| Pressure Range _____ Lbs. | Base Pressure _____ Lbs. | Rev. of Index Shaft _____ | STATION NUMBER _____ | _____       | _____     | _____      |
| Temp. Range _____ °F.     | Base Temp. _____ °F.     |                           |                      |             |           |            |

|                  |  | CORRECTED |           | UNCORRECTED |           | VEEDER INDEX UNCORRECTED |           |
|------------------|--|-----------|-----------|-------------|-----------|--------------------------|-----------|
|                  |  | MILLIONS  | THOUSANDS | MILLIONS    | THOUSANDS | MILLIONS                 | THOUSANDS |
| PRESENT READING  |  |           |           |             |           |                          |           |
| PREVIOUS READING |  |           |           |             |           |                          |           |
| DIFFERENCE       |  |           |           |             |           |                          |           |

VERIFICATION OF CORRECTED COUNTER BUILDUP SINCE PREV. INSP. ON \_\_\_\_\_

ESTIMATED AVG. PRESS. \_\_\_\_\_ AVG. TEMP. \_\_\_\_\_ COMPARISON O. K.  YES  NO

UNCORRECTED DIFF. x PRESS. MULT. x TEMP. FACTOR \_\_\_\_\_

| TEST DATA |      |       |       |       |       |      |       |       |       |
|-----------|------|-------|-------|-------|-------|------|-------|-------|-------|
| PRESS.    | ACT. | REQ'D | DIFF. | %ACC. | TEMP. | ACT. | REQ'D | DIFF. | %ACC. |
|           |      |       |       |       |       |      |       |       |       |
|           |      |       |       |       |       |      |       |       |       |

| METER   |  |
|---|--|
| Meter Kind and Size _____   | Reduced Capacity _____ CFH   |
| Read Last Prover Test _____ M   | Present Rate _____ CFH   |
| Amt. Registered _____ M   | Meter Capacity _____ CFH   |
| Date Last Prover Test _____ 19  | Working Pressure _____ PSI   |
| Rotary Meter Diff.: Act. _____ in. Req'd _____ in.                          | REG. ON SLOW MOTION TEST YES <input type="checkbox"/> *NO <input type="checkbox"/>   |
| Oil Level Checked <input type="checkbox"/> Changed <input type="checkbox"/> | By-pass Valve Lubr. <input type="checkbox"/> Seal. <input type="checkbox"/> Oper. <input type="checkbox"/> None <input type="checkbox"/> |

| GAS PASSED DURING TEST |  | CORRECTED |           | UNCORRECTED |           | TEMP. FLOW | PRESS. LBS. | HOURLY RATE |
|------------------------|--|-----------|-----------|-------------|-----------|------------|-------------|-------------|
|                        |  | MILLIONS  | THOUSANDS | MILLIONS    | THOUSANDS |            |             |             |
| Index (After-Test)     |  |           |           |             |           |            |             |             |
| Index (Before Test)    |  |           |           |             |           |            |             |             |
| Reg. During Test       |  |           |           |             |           |            |             |             |

REMARKS:

| ESTIMATE OF UNMEASURED BYPASSED GAS |             |      |    | OUT OF TOLERANCE | <input type="checkbox"/> CSGM | <input type="checkbox"/> |
|-------------------------------------|-------------|------|----|------------------|-------------------------------|--------------------------|
| CU. FT. DIAL                        | AVG. PRESS. | FROM | TO | REMARKS (OVER)   | <input type="checkbox"/>      | * EXPLAIN                |

Witnessed By: \_\_\_\_\_ Test By: \_\_\_\_\_

ORIGINAL

COLOR - ORIGINAL - WHITE  
DUPLICATE - WHITE  
TRIPLICATE - WHITE



**Gas Standard**

Distribution Operations

|                               |   |  |
|-------------------------------|---|--|
| Effective Date:<br>07/16/1980 | <h2>Estimating and Reporting<br/>Bypassed Gas and Index Build-up</h2> | Standard Number:<br><b>GS 6400.150(CG)</b><br>P&P 724-15 |
| Supersedes:<br>N/A            |   | Page 12 of 17  |

**EXHIBIT B  
(4 of 4)**

FORM CG 6-16 CSD (3-72) COLUMBIA GAS SYSTEM

### ORIFICE METER TEST REPORT (AS FOUND)

|   |      |  |            |
|---|------|--|------------|
| STATION NAME _____  |      | CARD TYPE <b>3</b>   |            |
| TIME: HR. _____ MIN. _____ A.M. / P.M.  |      | MONTH _____ DAY _____ YEAR _____   | Seq. _____ |
| GAGE LINE LEAKAGE _____   |      | Date _____   |            |
| DIFF. CHANGED _____ %/MIN.  |      | Station No. _____  |            |
| STATIC CHANGED _____ #/MIN.   |      | Inspection or Test Code _____  |            |
| DIFFERENTIAL ELEMENT _____  |      | Orifice Plate Inspection Code _____  |            |
| Make _____  |      | Piping Leakage Inspection Code _____   |            |
| Chart Rotation: 24 Hr. <input type="checkbox"/> 7 Day <input type="checkbox"/> 8 Day <input type="checkbox"/> |      | Meter Tube Inspection Code _____   |            |
| 31 Day <input type="checkbox"/> Other _____   |      | STATIC ELEMENT   |            |
| Chart No. _____   |      | Range _____ Psia   |            |
| Gage Range _____ Oper. Diff. _____  |      | TEST GAGE RECORDER   |            |
| Pen Arc _____ Pen. Lag _____  |      | Oper. Press. _____ Psia  |            |
| Zero: Under Press. _____ Atm. Press. _____  |      | Deadwt. <input type="checkbox"/> Merc. Man. <input type="checkbox"/>   |            |
| Friction: Under Press. _____ Atm. Press. _____  |      | Test Gage <input type="checkbox"/>   |            |
| Manometer Fluid: Water <input type="checkbox"/> Mercury <input type="checkbox"/>                              |      | TEMPERATURE ELEMENT  |            |
| UP TEST   |      | TEST RECORDER  |            |
| DOWN TEST   |      | Range _____ °F   |            |
| Man.  | Gage | ORIFICE PLATE  |            |
| Man.  | Gage | No. _____ Size _____ " x "   |            |
|   |      | I. D. _____ " Avg. _____ "   |            |
|   |      | Plate Thickness _____ " O. D. _____ "  |            |
|   |      | Edges Sharp Yes <input type="checkbox"/> No * <input type="checkbox"/>   |            |
|   |      | Plate Clean Yes <input type="checkbox"/> No * <input type="checkbox"/>   |            |
|   |      | Buckle Within Tol. Yes <input type="checkbox"/> No * <input type="checkbox"/>  |            |
|   |      | METER TUBES  |            |
|   |      | Foreign Material in Tubes Yes * <input type="checkbox"/> No <input type="checkbox"/>   |            |
|   |      | Straightening Vanes Clean Yes <input type="checkbox"/> No * <input type="checkbox"/>   |            |
|   |      | Auto Valve Test <input type="checkbox"/> Leaks Yes * <input type="checkbox"/> No <input type="checkbox"/>                              |            |
|   |      | Auto Valve Opens At _____ " Closes At _____ "  |            |
|   |      | Tap Holes Clean Yes <input type="checkbox"/> No * <input type="checkbox"/>   |            |
|   |      | Correct Gasket Yes <input type="checkbox"/> No * <input type="checkbox"/>  |            |
|   |      | By Pass Valve Seal <input type="checkbox"/> Lub. <input type="checkbox"/> Oper. <input type="checkbox"/> None <input type="checkbox"/> |            |
| REMARKS _____   |      |  |            |
| * (Explain) _____   |      |  |            |
| _____   |      |  |            |
| _____   |      |  |            |
| _____   |      |  |            |
| Witnessed By _____  |      | Test By _____  |            |
| ORIGINAL  |      |  |            |

COLOR - ORIGINAL - WHITE  
DUPLICATE - WHITE  
TRIPLICATE - WHITE



Distribution Operations

|                               |   |  |
|-------------------------------|---|--|
| Effective Date:<br>07/16/1980 | <b>Estimating and Reporting<br/>Bypassed Gas and Index Build-up</b> | Standard Number:<br><b>GS 6400.150(CG)</b><br>P&P 724-15 |
| Supersedes:<br>N/A            |   | Page 13 of 17  |

**EXHIBIT C  
(1 of 5)**

EXAMPLES SHOWING REQUIRED BYPASSING INFORMATION  
FOR  
DIAPHRAGM, ROTARY AND TURBINE METERS

The following examples, 1 through 8, show the information required for those conditions indicated when estimating bypassed gas at a station where diaphragm, rotary or turbine meters are installed. That part of the form shown is an enlargement of the bottom part of three Test Report forms, Form Numbers CS 6-183, Meter Test Report (As Found - Transfer Prover); CS 6-21, Meter Test Report (As Found - Orifice Prover); and CS 6-23, Integrating Index Test Report.

Example 1. Dual meters; all tests within tolerance, less than one Mscf index build-up, all gas measured, do not send copy to the Gas Measurement Section.

| GAS PASSED DURING TEST | CORRECTED |           | UNCORRECTED |           |   |   | TEMP FLOW | PRESS. IN. OF LBS. | HOURLY RATE |
|------------------------|-----------|-----------|-------------|-----------|---|---|-----------|--------------------|-------------|
|                        | MILLIONS  | THOUSANDS | MILLIONS    | THOUSANDS |   |   |           |                    |             |
| Index (After Test)     |           |           | 7           | 6         | 5 | 4 | 1         | 78.0               | 2000        |
| Index (Before Test)    |           |           | 7           | 6         | 5 | 4 | 0         | 75.0               | 1500        |
| Reg. During Test       |           |           |             |           |   |   | 1         |                    |             |

FOUND CONDITIONS: VALVES \_\_\_\_\_ DIAPHRAGM \_\_\_\_\_

REMARKS: \*(EXPLAIN) All gas measured by parallel meter, 11 am to 2 pm

Witnessed By \_\_\_\_\_ Test By \_\_\_\_\_

Example 2. Single meter; meter test out of tolerance, bypassed gas, index build-up, send chart and copy of the Test Report to the Gas Measurement Section.

| GAS PASSED DURING TEST | CORRECTED |           | UNCORRECTED |           |   |   | TEMP FLOW | PRESS. IN. OF LBS. | HOURLY RATE |
|------------------------|-----------|-----------|-------------|-----------|---|---|-----------|--------------------|-------------|
|                        | MILLIONS  | THOUSANDS | MILLIONS    | THOUSANDS |   |   |           |                    |             |
| Index (After Test)     |           |           | 2           | 4         | 6 | 4 | 2         | 44                 | 3400        |
| Index (Before Test)    |           |           | 2           | 4         | 6 | 0 | 6         | 65.2               | 2600        |
| Reg. During Test       |           |           |             |           | 3 | 6 |           |                    |             |

FOUND CONDITIONS: VALVES \_\_\_\_\_ DIAPHRAGM \_\_\_\_\_

REMARKS: \*(EXPLAIN) Estimate 9,000 cu. ft. (uncorrected) at 64.9# and 44°F bypassed from 9 am to 12 noon. "Meter out of tolerance." - C & CSGM

Witnessed By \_\_\_\_\_ Test By \_\_\_\_\_



Distribution Operations

|                               |   |  |
|-------------------------------|---|--|
| Effective Date:<br>07/16/1980 | <b>Estimating and Reporting<br/>Bypassed Gas and Index Build-up</b> | Standard Number:<br><b>GS 6400.150(CG)</b> |
| Supersedes:<br>N/A            |   | P&P 724-15<br><br>Page 14 of 17            |

**EXHIBIT C  
(2 of 5)**

EXAMPLES SHOWING REQUIRED BYPASSING INFORMATION  
FOR  
DIAPHRAGM, ROTARY AND TURBINE METERS

Example 3. Single meter; all tests within tolerance, bypassed gas and index build-up less than one Mscf, do not send copy of Test Report to the Gas Measurement Section.

| GAS PASSED DURING TEST | CORRECTED |           | UNCORRECTED |           |   |   | TEMP. FLOW | PRESS. IN. O <sub>2</sub> -LBS. | HOURLY RATE |
|------------------------|-----------|-----------|-------------|-----------|---|---|------------|---------------------------------|-------------|
|                        | MILLIONS  | THOUSANDS | MILLIONS    | THOUSANDS |   |   |            |                                 |             |
| Index (After Test)     |           |           | 0           | 2         | 6 | 8 | 6          | 36.0                            | 50          |
| Index (Before Test)    |           |           | 0           | 2         | 6 | 8 | 4          | 36.0                            | 100         |
| Reg. During Test       |           |           |             |           |   |   | 2          |                                 |             |

FOUND CONDITIONS: VALVES \_\_\_\_\_ DIAPHRAGM \_\_\_\_\_  
REMARKS: \*(EXPLAIN) Bypass gas & index build-up less than 1 Mscf, 9 am to 11:30 am

Witnessed By \_\_\_\_\_ Test By \_\_\_\_\_

Example 4a. Single meter; all tests within tolerance, bypassed gas in excess of one Mscf, erratic flow pattern, send copy of Test Report to the Gas Measurement Section.

| GAS PASSED DURING TEST | CORRECTED |           | UNCORRECTED |           |   |   | TEMP. FLOW | PRESS. IN. O <sub>2</sub> -LBS. | HOURLY RATE |
|------------------------|-----------|-----------|-------------|-----------|---|---|------------|---------------------------------|-------------|
|                        | MILLIONS  | THOUSANDS | MILLIONS    | THOUSANDS |   |   |            |                                 |             |
| Index (After Test)     |           |           | 2           | 4         | 6 | 1 | 6          | 78                              | 0           |
| Index (Before Test)    |           |           | 2           | 4         | 6 | 0 | 0          | 72                              | 5000        |
| Reg. During Test       |           |           |             |           |   | 1 | 6          |                                 |             |

FOUND CONDITIONS: VALVES \_\_\_\_\_ DIAPHRAGM \_\_\_\_\_  
REMARKS: \*(EXPLAIN) Estimate 6250 cu. ft. (uncorrected) at 25.3 # & 72°F bypassed from 11 am to 4 pm (load on approx. 1/4 of time) CSGM

Witnessed By \_\_\_\_\_ Test By \_\_\_\_\_

Example 4b. Single meter; all tests within tolerance, bypassed gas in excess of one Mscf, erratic flow pattern, send copy of Test Report to the Gas Measurement Section.

| GAS PASSED DURING TEST | CORRECTED |           | UNCORRECTED |           |   |   | TEMP. FLOW | PRESS. IN. O <sub>2</sub> -LBS. | HOURLY RATE |
|------------------------|-----------|-----------|-------------|-----------|---|---|------------|---------------------------------|-------------|
|                        | MILLIONS  | THOUSANDS | MILLIONS    | THOUSANDS |   |   |            |                                 |             |
| Index (After Test)     |           |           | 3           | 4         | 8 | 6 | 2          | 7                               | 4000        |
| Index (Before Test)    |           |           | 3           | 4         | 8 | 6 | 2          | 7                               | 0           |
| Reg. During Test       |           |           |             |           |   |   | 0          |                                 |             |

FOUND CONDITIONS: VALVES \_\_\_\_\_ DIAPHRAGM \_\_\_\_\_  
REMARKS: \*(EXPLAIN) Estimate 12,000 cu. ft. (uncorrected) at 78 # bypassed from 12 noon to 4 pm (gas used at max. rate for 3 hours) CSGM

Witnessed By \_\_\_\_\_ Test By \_\_\_\_\_





**Gas Standard**

Distribution Operations

|                               |   |  |
|-------------------------------|---|--|
| Effective Date:<br>07/16/1980 | <b>Estimating and Reporting<br/>Bypassed Gas and Index Build-up</b> | Standard Number:<br><b>GS 6400.150(CG)</b><br>P&P 724-15 |
| Supersedes:<br>N/A            |   | Page 15 of 17  |

**EXHIBIT C  
(3 of 5)**

EXAMPLES SHOWING REQUIRED BYPASSING INFORMATION  
FOR  
DIAPHRAGM, ROTARY AND TURBINE METERS

Example 5. Dual meters; part of load measured and part bypassed. Bypassed gas in excess of one Mscf and calculated using the ratio method. Send copy of Test Report to the Gas Measurement Section.

NOTE: This procedure is very seldom used and can become quite involved. Meterman should retain record of computation until billing has been cleared. (See Exhibit A.)

| GAS PASSED DURING TEST | CORRECTED |           |          |           | UNCORRECTED |           |          |           | TEMP FLOW | PRESS. LBS. | HOURLY RATE |      |        |
|------------------------|-----------|-----------|----------|-----------|-------------|-----------|----------|-----------|-----------|-------------|-------------|------|--------|
|                        | MILLIONS  | THOUSANDS | MILLIONS | THOUSANDS | MILLIONS    | THOUSANDS | MILLIONS | THOUSANDS |           |             |             |      |        |
| Index (After Test)     |           |           |          |           | 3           | 4         | 2        | 8         | 0         | 5           | 46          | 44.0 | 25,650 |
| Index (Before Test)    |           |           |          |           | 3           | 4         | 2        | 8         | 0         | 5           | 44          | 42.0 | 17,500 |
| Reg. During Test       |           |           |          |           |             |           |          |           |           | 0           |             |      |        |

FOUND CONDITIONS: VALVES \_\_\_\_\_ DIAPHRAGM \_\_\_\_\_  
REMARKS: \*(EXPLAIN) Repaired meter (see over) - Estimate 153,800 cu. ft. (uncorrected) at 43 # & 45°F bypassed from 9 am to 3 pm (Ratio Method) CSGM  
Witnessed By \_\_\_\_\_ Test By \_\_\_\_\_

Example 6. Integrating index test; test within tolerance, corrected counter disengaged, uncorrected counter engaged, index build-up less than one Mscf, do not send copy of Test Report to the Gas Measurement Section.

| GAS PASSED DURING TEST              | CORRECTED   |           |          |           | UNCORRECTED |           |          |   | TEMP FLOW | PRESS. LBS.                               | HOURLY RATE |                               |   |      |     |
|-------------------------------------|-------------|-----------|----------|-----------|-------------|-----------|----------|---|-----------|---|-------------|-------------------------------|---|------|-----|
|                                     | MILLIONS    | THOUSANDS | MILLIONS | THOUSANDS | MILLIONS    | THOUSANDS | MILLIONS | THOUSANDS                               |           |   |             |                               |   |      |     |
| Index (After-Test)                  | 0           | 7         | 5        | 2         | 4           | 6         | 2        | 8                                       | 6         | 5   | 2           | 6                             | - | 31.2 | 200 |
| Index (Before Test)                 | 0           | 7         | 5        | 2         | 4           | 6         | 2        | 8                                       | 6         | 5   | 2           | 4                             | - | 31.2 | 600 |
| Reg. During Test                    |             |           |          |           |             |           |          |   |           |   |             |                               |   |      |     |
| REMARKS:                            |             |           |          |           |             |           |          |   |           |   |             |                               |   |      |     |
| ESTIMATE OF UNMEASURED BYPASSED GAS |             |           |          |           |             |           |          |   |           | OUT OF TOLERANCE <input type="checkbox"/> |             | CSGM <input type="checkbox"/> |   |      |     |
| CU. FT. DIAL                        | AVG. PRESS. | FROM      | TO       |           |             |           |          | REMARKS (OVER) <input type="checkbox"/> |           | *EXPLAIN                                  |             |                               |   |      |     |
| Witnessed By:                       |             |           |          |           |             | Test By:  |          |   |           |   |             |                               |   |      |     |

ORIGINAL





Distribution Operations

|                               |   |  |
|-------------------------------|---|--|
| Effective Date:<br>07/16/1980 | <b>Estimating and Reporting<br/>Bypassed Gas and Index Build-up</b> | Standard Number:<br><b>GS 6400.150(CG)</b><br>P&P 724-15 |
| Supersedes:<br>N/A            |   | Page 16 of 17  |

**EXHIBIT C  
(4 of 5)**

EXAMPLES SHOWING REQUIRED BYPASSING INFORMATION  
FOR  
DIAPHRAGM, ROTARY AND TURBINE METERS

Example 7. Integrating index test; test within tolerance, corrected counter disengaged, uncorrected counter engaged, index build-up in excess of one Mscf, send copy of Test Report to the Gas Measurement Section.

| GAS PASSED DURING TEST              | CORRECTED |   |   |             |   |   | UNCORRECTED |      |  |           |  |    | TEMP. FLOW | PRESS. LBS. | HOURLY RATE |                  |   |                          |                          |                                     |  |
|-------------------------------------|-----------|---|---|-------------|---|---|-------------|------|--|-----------|--|----|------------|-------------|-------------|------------------|---|--------------------------|--------------------------|-------------------------------------|--|
|                                     | MILLIONS  |   |   | THOUSANDS   |   |   | MILLIONS    |      |  | THOUSANDS |  |    |            |             |             |                  |   |                          |                          |                                     |  |
| Index (After-Test)                  | 0         | 6 | 1 | 2           | 4 | 3 |             |      |  |           |  |    | 2          | 8           | 6           | 5                | 6 | 6                        | 46.2                     | 1800                                |  |
| Index (Before Test)                 | 0         | 6 | 1 | 2           | 4 | 3 |             |      |  |           |  |    | 2          | 8           | 6           | 5                | 2 | 0                        | 46.2                     | 1200                                |  |
| Reg. During Test                    |           |   |   |             |   |   |             |      |  |           |  |    |            |             |             |                  | 4 | 6                        |                          |                                     |  |
| REMARKS:                            |           |   |   |             |   |   |             |      |  |           |  |    |            |             |             |                  |   |                          |                          |                                     |  |
| ESTIMATE OF UNMEASURED BYPASSED GAS |           |   |   |             |   |   |             |      |  |           |  |    |            |             |             |                  |   |                          |                          |                                     |  |
| CU. FT. DIAL                        |           |   |   | AVG. PRESS. |   |   |             | FROM |  |           |  | TO |            |             |             | OUT OF TOLERANCE |   | <input type="checkbox"/> | CSGM                     | <input checked="" type="checkbox"/> |  |
| REMARKS (OVER)                      |           |   |   |             |   |   |             |      |  |           |  |    |            |             |             |                  |   |                          | <input type="checkbox"/> | * EXPLAIN                           |  |
| Witnessed By:                       |           |   |   |             |   |   |             |      |  | Test By:  |  |    |            |             |             |                  |   |                          |                          |                                     |  |

ORIGINAL

Example 8. Integrating index test; test out of tolerance, corrected counter disengaged, meter on bypass, no index build-up, send copy of the Test Report to the Gas Measurement Section.

| GAS PASSED DURING TEST                                    | CORRECTED |   |   |             |   |   | UNCORRECTED |      |  |           |  |    | TEMP. FLOW | PRESS. LBS. | HOURLY RATE |                  |   |                                     |                          |                                     |  |
|---|-----------|---|---|-------------|---|---|-------------|------|--|-----------|--|----|------------|-------------|-------------|------------------|---|-------------------------------------|--------------------------|-------------------------------------|--|
|   | MILLIONS  |   |   | THOUSANDS   |   |   | MILLIONS    |      |  | THOUSANDS |  |    |            |             |             |                  |   |                                     |                          |                                     |  |
| Index (After-Test)  | 0         | 6 | 1 | 2           | 4 | 3 |             |      |  |           |  |    | 2          | 8           | 6           | 5                | 6 | 6                                   | 46.2                     | 1800                                |  |
| Index (Before Test)                                       | 0         | 6 | 1 | 2           | 4 | 3 |             |      |  |           |  |    | 2          | 8           | 6           | 5                | 6 | 6                                   | 46.2                     | 1200                                |  |
| Reg. During Test  |           |   |   |             |   |   |             |      |  |           |  |    |            |             |             |                  |   |                                     |                          |                                     |  |
| REMARKS:  |           |   |   |             |   |   |             |      |  |           |  |    |            |             |             |                  |   |                                     |                          |                                     |  |
| Meter out of service while repairing and calibrating BVI. |           |   |   |             |   |   |             |      |  |           |  |    |            |             |             |                  |   |                                     |                          |                                     |  |
| ESTIMATE OF UNMEASURED BYPASSED GAS                       |           |   |   |             |   |   |             |      |  |           |  |    |            |             |             |                  |   |                                     |                          |                                     |  |
| CU. FT. DIAL  |           |   |   | AVG. PRESS. |   |   |             | FROM |  |           |  | TO |            |             |             | OUT OF TOLERANCE |   | <input checked="" type="checkbox"/> | CSGM                     | <input checked="" type="checkbox"/> |  |
| REMARKS (OVER)  |           |   |   |             |   |   |             |      |  |           |  |    |            |             |             |                  |   |                                     | <input type="checkbox"/> | * EXPLAIN                           |  |
| Witnessed By:   |           |   |   |             |   |   |             |      |  | Test By:  |  |    |            |             |             |                  |   |                                     |                          |                                     |  |

ORIGINAL



Distribution Operations

|                               |   |  |
|-------------------------------|---|--|
| Effective Date:<br>07/16/1980 | <b>Estimating and Reporting<br/>Bypassed Gas and Index Build-up</b> | Standard Number:<br><b>GS 6400.150(CG)</b><br>P&P 724-15 |
| Supersedes:<br>N/A            |   | Page 17 of 17  |

**EXHIBIT C  
(5 of 5)**

**EXAMPLES SHOWING REQUIRED BYPASSING INFORMATION  
FOR  
ORIFICE METERS**

---

The following examples, 1 through 3, show how to report estimated bypassed gas when performing work on an orifice meter or orifice meter gauge. The appropriate bypassing information for the respective orifice meter shall be recorded in the Remarks section of Form Number CS 6-16, Orifice Meter Test Report (As Found), and also in the Remarks block on the back of the orifice meter chart.

- Example 1. Gauge out of service - 3/6/76, 3 pm to 4:15 pm - Estimate as in continuous service.
- Example 2. Orifice meter bypassed - 3/6/76, 3 pm to 4:15 pm - Estimate as in continuous service.
- Example 3. Orifice meter out of service - 3/6/76, 3 pm to 4:15 pm - All gas measured by parallel meter(s).



Distribution Operations

|                               |  |  |
|-------------------------------|--|--|
| Effective Date:<br>07/15/1981 | <b>Metering Equipment Change<br/>Report (MECR) - Gas Measurement<br/>Billing (GMB)</b> | Standard Number:<br><b>GS 6400.170(CG)</b><br>P&P 724-17 |
| Supersedes:<br>N/A            |  | Page 1 of 7  |

Companies Affected:

|                                     |   |   |
|-------------------------------------|---|---|
| <input type="checkbox"/> NIPSCO     | <input checked="" type="checkbox"/> CGV | <input checked="" type="checkbox"/> CMD |
| <input type="checkbox"/> NIFL       | <input checked="" type="checkbox"/> CKY | <input checked="" type="checkbox"/> COH |
| <input type="checkbox"/> Kokomo Gas | <input type="checkbox"/> CMA            | <input checked="" type="checkbox"/> CPA |

**REFERENCE** Columbia Gas System Manual of Approved Procedures for Operations, Supplement No. 20.

**1. GENERAL REQUIREMENTS**

The Metering Equipment Change Report (MECR), Form CS 6-2-3 (Exhibit A), is used as the prime source of information for updating the master files of a GMB account by the Finance-Gas Measurement Section. It provides a uniform and controlled system of notifying the Gas Measurement Section and other concerned personnel of any movement or changes to measuring equipment that affects billing. The reports are consecutively numbered to enable their convenient and accurate referencing for verification of information.

**2. DETERMINING WHEN A METERING EQUIPMENT CHANGE REPORT (MECR) IS REQUIRED**

**2.1 Conditions When an MECR Report is Required**

The MECR Report shall be completed by the meter inspector when any item of metering or auxiliary measuring equipment that affects billing is installed, replaced, modified or removed.

A listing of specific conditions that require the completion of the MECR Report is shown in Exhibit B.

**2.2 Conditions When an MECR Report is Not Required**

- a. Changes to auxiliary non-measurement equipment, e.g., differential limit flow controllers, meter run shut-off valves, restriction plate, equalizing plates, etc.
- b. A billing address change.
- c. Replacement of a diaphragm meter valve plate mechanism.

*This document is considered CONTROLLED only when viewed electronically on the Company's intranet. Printed or other electronic copies may not be current, and the intranet version should be used to verify.*



Distribution Operations

|                               |  |  |
|-------------------------------|--|--|
| Effective Date:<br>07/15/1981 | <b>Metering Equipment Change<br/>Report (MECR) - Gas Measurement<br/>Billing (GMB)</b> | Standard Number:<br><b>GS 6400.170(CG)</b><br>P&P 724-17 |
| Supersedes:<br>N/A            |  | Page 2 of 7  |

**2.3 Other Conditions**

It is not necessary to complete an MECR Report when a new station is built until the station is placed in service, then one report will cover both the “install” and “turn-on.” If the turn-on is delayed for a period of three (3) months, the meter inspector shall complete the MECR Report reporting the station as connected and the meter as Shut Off-Left on Premises (SOLOP). When the station is placed in service, a second MECR Report shall be completed.

**3. COMPLETION OF MECR REPORT**

The following information shall be completed by the meter inspector prior to routing the MECR Report to the Gas Measurement Section for processing (see Section 4): (1) station name, (2) are ID, alpha prefix, station number and meter sequence number, (3) date (effective date of change), (4) time (effective time of change), and (5) signature of person completing the form.

Only the pertinent data applicable to the changes made need be completed in the body of the report. When changing meters, gauges, orifice plates, etc. or when making modifications; e.g., 7 day to 31 day, 10M scallop to 1M scallop, etc., the date and time shown on both the “removed” and the “installed” side of the report should be the same and reflect the time the work was completed. This procedure is followed in order to show no “break in service” to the customer and to allow for final processing of gas usage (bypassed gas, lost registration, erroneous registration, etc.) prior to the effective time of the change.

**4. ROUTING AND DISPOSITION OF COPIES**

**4.1 Original Copy (District or Division)**

The meter inspector shall route the original of the MECR Report to the Meter Records Section for posting (updating measuring station records), review and filing.

**4.2 Duplicate Copy (Office)**

- a. CDC Operated Measurement Stations - The meter inspector shall route the duplicate copy of the MECR Report through the area accounting office to the Finance-Gas Measurement Section when it is completed for the conditions listed 1 through 4 in Exhibit B. It may be forwarded directly to the Gas Measurement Section for other conditions in Exhibit B.
- b. TCO Operated Measurement Stations - When an MECR Report is



Distribution Operations

|                               |  |  |
|-------------------------------|--|--|
| Effective Date:<br>07/15/1981 | <b>Metering Equipment Change<br/>Report (MECR) - Gas Measurement<br/>Billing (GMB)</b> | Standard Number:<br><b>GS 6400.170(CG)</b><br>P&P 724-17 |
| Supersedes:<br>N/A            |  | Page 3 of 7  |

completed by Columbia Gas Transmission Corporation personnel operating Columbia Gas Distribution Companies owned measurement facilities, the duplicate copy of the MECR Report shall be routed through the area accounting office to the CDC Finance-Gas Measurement Section when it is completed for the conditions listed 1 through 11 in Exhibit B. It may be forwarded directly to the Gas Measurement Section for other conditions in Exhibit B.

Note: Special handling of the duplicate copy may be required by the area accounting office when it is used in conjunction with the processing of Form C-1275, "Excess Pressure Customer Billing Notification," (Exhibit C). Refer to applicable Company accounting procedures.

**4.3 Triplicate Copy (Meter Inspector)**

The meter inspector shall retain the triplicate copy for future reference.

**4.4 Additional Copies**

Under certain conditions, additional copies of the MECR Report may be necessary; for instance:

- a. The Continuing Property Records (CPR) Section of the Rates and Depreciation Department, Columbia Gas Distribution Companies, shall receive copies of the MECR Report for all:
  - 1. Measuring equipment installations
  - 2. Measuring equipment removals
  - 3. Measuring equipment replacements
  - 4. All facility name changes
  - 5. Where metering data is being telemetered into a Gas Control Center, it is necessary to notify them of changes in orifice plate sizes, the adding or removing of multiple meter runs from service, etc.
- b. Chart changers should be notified of changes that would affect their operations.

In such cases, a "machine copy" (Xerox or other) can be utilized.



Distribution Operations

|                               |  |  |
|-------------------------------|--|--|
| Effective Date:<br>07/15/1981 | <b>Metering Equipment Change<br/>Report (MECR) - Gas Measurement<br/>Billing (GMB)</b> | Standard Number:<br><b>GS 6400.170(CG)</b><br>P&P 724-17 |
| Supersedes:<br>N/A            |  | Page 4 of 7  |

**5. ADDITIONAL INSTRUCTIONS**

If two MECR Reports are required to process a particular change, cross reference the reports under "remarks" to alert the Finance-Gas Measurement Section, and to prevent the closing out of an account accidentally.

Insofar as possible, complete the MECR Report at the measuring station site. Show on the MECR Report both the "removed" and "installed" readings when replacing indexes, corrected or uncorrected counters, or rotary meter veeder counters. Include the model number of Mercury and Palmer Gauges in the appropriate "Instruments" block. Include the working pressure of all meters, except orifice meters, in the appropriate "Meter" block.

The recording chart shall be removed or changed when any item of metering or auxiliary equipment that affects billing is installed, re-placed, modified or removed. The date and time on both the "removed" and "placed" chart shall be the same as shown on the MECR Report. The duplicate copy of the MECR Report shall be attached to the chart (but not stapled) and both mailed to the appropriate Gas Measurement Section.



Gas Standard

Distribution Operations

|                               |  |  |
|-------------------------------|--|--|
| Effective Date:<br>07/15/1981 | <b>Metering Equipment Change Report (MECR) - Gas Measurement Billing (GMB)</b> | Standard Number:<br><b>GS 6400.170(CG)</b><br>P&P 724-17 |
| Supersedes:<br>N/A            |  | Page 5 of 7  |

EXHIBIT A

FORM CS 6-2-3 (2-81) CSD COLUMBIA GAS SYSTEM  
**METERING EQUIPMENT CHANGE REPORT 35603**

STATION ID NO. \_\_\_\_\_ DATE \_\_\_\_\_ AREA ID.-ALPHA PREFIX-STAT.NO.-SEQ. \_\_\_\_\_

MEAS. GAS FROM \_\_\_\_\_  
MEAS. GAS TO \_\_\_\_\_ STATION NAME (IF APPLICABLE) \_\_\_\_\_

MUNICIPALITY, TWP. OR DIST. \_\_\_\_\_ COUNTY \_\_\_\_\_ STATE \_\_\_\_\_

TYPE OF CHANGE     INSTALLED     TURNED ON     REMOVED     TURNED OFF

TIME    HR.    MIN.    AM/PM    HR.    MIN.    AM/PM

ORIFICE  
PLATE SIZE    " X "  
OTHER

OTHER METERS  
KIND, SIZE, WP.  
SERIAL NUMBER  
TYPE OF INDEX    CIRCULAR DIAL  DIGITAL     CIRCULAR DIAL  DIGITAL   
INDEX PROVING HAND    CU.FT./REV.    CU.FT./REV.  
INTERMEDIATE GEAR RATIO (DIAPHRAGM METERS ONLY)    - 1    - 1  
INDEX OR COUNTER READING (UNCORRECTED)    MILLIONS THOUSANDS    MILLIONS THOUSANDS

INSTRUMENTS  
MFG. & TYPE  
MODEL & SERIAL NO.  
CHART NUMBER    CGS #    CGS #  
STATIC PRESSURE RANGE    PSIG    PSIG  
DIFFERENTIAL PRESSURE RANGE    INCHES    INCHES  
TEMPERATURE RANGE    OF    OF  
CHART REV. OR SCALLOP    MCF/SCAL REV     MCF/SCAL REV   
CHART ROTATION: 24 HR 7 DAY, ETC. (CLOCKDRIVEN)    HR/DAY    HR/DAY  
INTEGRATING INDEX READING (CORRECTED)    MILLIONS THOUSANDS    MILLIONS THOUSANDS  
PRESS. BASE    PSIA

METER STATUS AS LEFT    ACTIVE     SOLOP

IF STATION NAME CHANGE SHOW FORMER NAME \_\_\_\_\_

REMARKS \_\_\_\_\_

SIGNED \_\_\_\_\_ REVIEWED BY \_\_\_\_\_

INSTALLED    ORIGINAL    REMOVED

"Place left inside edge of orifice on left end of scale and mark both edges on scale."  
"Place left inside edge of orifice on left end of scale and mark both edges on scale."

COLOR - ORIGINAL - LIGHT BLUE  
DUPLICATE - LIGHT BLUE  
TRIPPLICATE - LIGHT BLUE

SIZE - 6" x 8" (As Shown)



Distribution Operations

|                               |  |  |
|-------------------------------|--|--|
| Effective Date:<br>07/15/1981 | <b>Metering Equipment Change<br/>Report (MECR) - Gas Measurement<br/>Billing (GMB)</b> | Standard Number:<br><b>GS 6400.170(CG)</b><br>P&P 724-17 |
| Supersedes:<br>N/A            |  | Page 6 of 7  |

**EXHIBIT B**

The following is a list of specific conditions that require the completion of the Metering Equipment Change Report (MECR), Form CS 6-2-3 CSD:

1. New account - installation of a measuring station.
2. Change in alpha prefix, station number, or meter sequence number.
3. Name change of customer.
4. Ownership change without name change (if requested by local office).
5. Complete removal of a measuring station.
6. Installation of an additional meter within an existing measuring station.
7. Removal of a meter no longer required, but not a complete removal of the entire station.
8. Turn-on of a meter subsequent to time of installation or turn-on of an idle meter.
9. Meter turn-off; i.e., Shut Off-Left On Premises (SOLOP).
10. Installation, turn-on, turn-off or removal of a sub-meter set in conjunction with an excess pressure account.
11. Installation, turn-on, turn-off or removal of a meter set on "combined billing" with an excess pressure account or a separate gas measurement low pressure account or a pressure compensated/ fixed factor station billed through chart processing.
12. Meter change.
13. Replacement of meter indexes or counters.
14. Replacement of a turbine meter module or CVM rotary meter cartridge.
15. Installation of a new instrument or replacement of an existing instrument on an existing meter within a measuring station.
16. Installation or removal of a temperature recorder.
17. Removal of an instrument no longer required.
18. Change in chart revolution on meter driven gauges.
19. Change in chart rotation on clock driven gauges.
20. Change in chart scallop.
21. Change in pressure or temperature element range.
22. Change in type of chart calibration; e.g., Metric to Mercury.
23. Replacement of corrected or uncorrected counters on integrating indexes.
24. Changes in base pressure or base temperature of an integrating index.
25. Change in orifice plate size.
26. Installation, removal or range change of a gravitometer.
27. Installation or removal of a calorimeter used for billing.
28. Replacement of orifice meter tube.





Gas Standard

Distribution Operations

|                               |  |  |
|-------------------------------|--|--|
| Effective Date:<br>07/15/1981 | <b>Metering Equipment Change Report (MECR) - Gas Measurement Billing (GMB)</b> | Standard Number:<br><b>GS 6400.170(CG)</b><br>P&P 724-17 |
| Supersedes:<br>N/A            |  | Page 7 of 7  |

EXHIBIT C

FORM C 3275 CGO 10/78 COLUMBIA GAS DISTRIBUTION COMPANIES EXCESS PRESSURE CUSTOMER BILLING NOTIFICATION GAS MEASUREMENT SECTION (FIG. 4)

|  |  |                                  |   |                                |   |   |          |
|--|--|----------------------------------|---|--------------------------------|---|---|----------|
| ACTION   |  | <input type="checkbox"/> NEW SET | <input type="checkbox"/> DISCONNECT/CONNECT | <input type="checkbox"/> FINAL | <input type="checkbox"/> CHANGE - OTHER | EFFECTIVE DATE  |          |
| LINES  | 1 - 21   | A - C and 1 - 21                 | A - C                                       | A and 1 - 21                   |   |   |          |
| PRESENT CUSTOMER BILLING NAME & IDENTIFICATION |  |                                  |   |                                |   |   |          |
| A  | FINAL BILL ADDRESS: STREET   |                                  |   |                                |   | GC  | D        |
| B  | CITY   |                                  |   |                                |   | STATE   | ZIP CODE |
| C  | CUSTOMER BILLING NAME  |                                  |   |                                |   | UN  | BK       |
| 1  | MAILING ADDRESS: STREET  |                                  |   |                                |   | ACCT  | C        |
| 2  | CITY   |                                  |   |                                |   | STATE   | ZIP CODE |
| 3  | SERVICE ADDRESS: STREET  |                                  |   |                                |   | CITY  | STATE    |
| 4  | PROPERTY OWNER: NAME & ADDRESS   |                                  |   |                                |   | STATE   | ZIP CODE |
| 5  | MEASUREMENT STATION: NUMBER  |                                  |   |                                |   | GAS IN LINE OWNED BY: DISTRIBUTION CO. TRANSMISSION CO.   |          |
| 6  | GROUP/COMPANY - DISTRICT - LOCAL OFFICE:   |                                  |   |                                |   | GC  | D        |
| 7  | UNIT - BOOK - ACCOUNT NUMBER: (New Account No. assigned by Gen. Office)  |                                  |   |                                |   | UN  | BK       |
| 8  | COUNTY: NAME   |                                  |   |                                |   | ACCT  | C        |
| 9  | COMMUNITY: NAME  |                                  |   |                                |   | <input type="checkbox"/> MASTER METERED<br><input type="checkbox"/> NOT MASTER METERED  |          |
| 10   | MARKET AREA CODE:  |                                  |   |                                |   | NUMBER  |          |
| 11   | RATE: SCHEDULE OR CONTRACT TITLE   |                                  |   |                                |   | <input type="checkbox"/> CONTRACT GEN. SERVICE<br><input type="checkbox"/> AIR COND. UNDER 10 TON<br><input type="checkbox"/> AIR COND. OVER 10 TON |          |
| 12   | CIS BILLING RATE CODE:   |                                  |   |                                |   | NUMBER  |          |
| 13   | REVENUE CLASS: TITLE   |                                  |   |                                |   | <input type="checkbox"/> PUBLIC AUTHORITY   |          |
| 14   | STANDARD INDUSTRIAL CLASSIFICATION CODE:   |                                  |   |                                |   | NUMBER  |          |
| 15   | MEASUREMENT PRESSURE BASE:   |                                  |   |                                |   | PSIA  |          |
| 16   | ADD ON TAXES TYPE: <input type="checkbox"/> EXCISE <input type="checkbox"/> SCHOOL <input type="checkbox"/> SALES LOCAL/STATE <input type="checkbox"/> |                                  |   |                                |   | PERCENT   |          |
| 17   | PERCENT:   |                                  |   |                                |   |   |          |
| 18   | GAS CONSUMPTION EXEMPT FROM ADD ON TAX:  |                                  |   |                                |   | DOLLARS   |          |
| 19   | BILL AMOUNT TAXABLE LIMITATION:  |                                  |   |                                |   | NUMBER  |          |
| 20   | LIVING UNITS SUBJECT TO MINIMUM CHARGE IN SINGLE METERED MULTIPLE FAMILY DWELLING:   |                                  |   |                                |   | NUMBER  |          |
| ADDITIONAL DATA OR INSTRUCTIONS*               |  |                                  |   |                                |   |   |          |
| INITIATED BY LOCATION DATE APPROVED BY         |  |                                  |   |                                |   |   |          |
| GAS MEASUREMENT SECTION: PROCESSED BY DATE     |  |                                  |   |                                |   |   |          |

\* SEE FIELD INSTRUCTIONS ON REVERSE

COLOR - ORIGINAL - WHITE  
 DUPLICATE - PINK  
 TRIPPLICATE - BLUE  
 4TH COPY - YELLOW  
 5TH COPY - WHITE  
 6TH COPY - WHITE

SIZE - 8-1/2" X 11"



Distribution Operations

|                               |  |  |
|-------------------------------|--|--|
| Effective Date:<br>05/07/1980 | <b>Bypassing of Measuring Stations</b> | Standard Number:<br><b>GS 6400.180(CG)</b><br>P&P 724-18 |
| Supersedes:<br>N/A            |  | Page 1 of 5  |

Companies Affected:

|                                     |   |   |
|-------------------------------------|---|---|
| <input type="checkbox"/> NIPSCO     | <input checked="" type="checkbox"/> CGV | <input checked="" type="checkbox"/> CMD |
| <input type="checkbox"/> NIFL       | <input checked="" type="checkbox"/> CKY | <input checked="" type="checkbox"/> COH |
| <input type="checkbox"/> Kokomo Gas | <input type="checkbox"/> CMA            | <input checked="" type="checkbox"/> CPA |

**REFERENCE**    None

**1. GENERAL REQUIREMENTS**

Bypasses must be operated in a correct manner to insure uninterrupted service to the customer and to prevent damage to metering equipment. It is very important that meter index registrations and the flow rate be noted before and after any bypassing of measuring equipment and all bypassed gas accounted for (Refer to [GS 6400.150\(CG\)](#) “Estimating and Reporting Bypassed Gas and Index Build-Up”). In some cases, it may be necessary to verify large estimates with a plant representative or secure the aid of the local Industrial Engineer or gas utilization representative.

A sketch of the bypass piping configuration showing the location of valves and a suitable method of sequencing the valves should be posted in any measuring station where the valving arrangements are complicated. It is important that Measurement and Regulation (M & R) personnel familiarize themselves with the aforementioned valving sketch and become knowledgeable of any particular operating conditions before any actual bypassing of gas is performed. Operating conditions that may be encountered are:

- a. In some locations, the regulation, refer to [GS 1750.010](#) “Pressure Regulator Station Inspection and Maintenance.” as well as the measurement must be bypassed making it necessary to either regulate manually or make other arrangements, such as installing a regulator in the bypass, or as a last resort, turning off the gas to the customer.
- b. During bypassing, slight variations in the delivered pressure may affect the operation of the customer's equipment. The customer shall be advised in advance of the bypassing operation so that any necessary measures can be taken.
- c. There are local conditions that require the Company to contact the customer with regard to bypassing gas.

*This document is considered CONTROLLED only when viewed electronically on the Company's intranet. Printed or other electronic copies may not be current, and the intranet version should be used to verify.*



Distribution Operations

|                               |  |  |
|-------------------------------|--|--|
| Effective Date:<br>05/07/1980 | <b>Bypassing of Measuring Stations</b> | Standard Number:<br><b>GS 6400.180(CG)</b><br>P&P 724-18 |
| Supersedes:<br>N/A            |  | Page 2 of 5  |

**2. OPERATING METERS OVER CAPACITY AT MULTIPLE METER STATIONS**

- a. Diaphragm, rotary and turbine meters can be operated over capacity for a period of one hour to permit continued measurement (gauges and indexes remain in operation) during a bypassing operation, as long as there is no adverse pressure drop at the outlet of the measuring station.
  - 1. Diaphragm meters, depending on the meter operating pressure, can be operated at differential pressures exceeding 2" w.c. Refer to Exhibit A to determine maximum differential pressure and dial rate allowed.
  - 2. The "old style" Roots meter may be operated to 150 percent of its rated capacity.
  - 3. The new "in-line" Roots meter may be operated to 120 percent of its rated capacity.
  - 4. The turbine meter may be operated to 120 percent of its rated capacity.
- b. Differential orifice gauges may be temporarily removed from service and gas delivered through an orifice meter in excess of the gauge range. When this procedure is followed, the estimating and re-reporting of bypassed gas should be in accordance with [GS 6400.150\(CG\)](#) "Estimating and Reporting Bypassed Gas and Index Build-Up."

**3. PRACTICES TO BE OBSERVED IN BYPASSING**

- a. Notify customer representative, if required.
- b. If a blind plate is installed in the bypass the inlet and outlet valves of the bypass must be closed before removing the plate. Then slowly bleed down the piping on both sides of the plate to atmospheric pressure, remove the plate, purge the bypass, and then re-pressure
- c. Mount a pressure indicating gauge on the outlet of the measuring station. If the station is regulated on the outlet, mount the gauge between the measurement outlet and regulator inlet.
- d. If meter runs are automatically operated, the differential limit flow controllers that operate the meter run shut-off valves shall be removed from service prior to bypassing. This is accomplished by shutting off the supply and venting the line to the halve diaphragm head to atmosphere. The controller(s) should then be placed in the "out of service" position.
- e. In stations where the meters are operating, observe the drop in the differential pressure for orifice meters, or a decrease in meter flow rate for other types of



Distribution Operations

|                               |   |  |
|-------------------------------|---|--|
| Effective Date:<br>05/07/1980 | <h2 style="margin: 0;">Bypassing of Measuring Stations</h2> | Standard Number:<br><b>GS 6400.180(CG)</b><br>P&P 724-18 |
| Supersedes:<br>N/A            |   | Page 3 of 5  |

meters as the bypass is opened. When bypassing, particular care must be taken if there is little or no flow through the station to assure uninterrupted service to the customer.

- f. While slowly turning off the inlet valve of the meter being by-passed, observe the pressure indicating gauge installed on the station outlet to assure that pressures continue to be sufficient to operate the customer's equipment, then, shut off the meter outlet valve.
- g. In multiple orifice meter stations where no bypass is installed, it may be necessary to remove the orifice plate from one orifice meter to make it useable as a bypass so work can be done on a parallel orifice meter.
- h. When placing meters back in service, observe same precautions as when bypassing. Be sure air is purged from meter(s) and piping. Crack meter valve(s) and re-pressure gradually. The differential pressure or flow rate is indicative of that portion of the gas flowing through the meter(s) as they are turned on. As the bypass is closed, observe that there is an increase in delivery through the meter(s) and observe the pressure indicating gauge previously installed on the station outlet to see that the pressure remains normal.
- i. Place the automatic valve differential limit controllers back in service, being careful not to inadvertently turn off a meter that necessarily needs to be open to flow.
- j. Seal or lock the bypass valve in a closed position, or if necessary, install a blind plate. The use of a blind gasket when in-stalling a blind plate is prohibited. The blind plate shall be identified (stamped, marked or tagged) "Blind Plate" in a conspicuous location.
- k. Make a complete check of all piping and valves to verify that all equipment has been placed back in service and is operating properly.



Distribution Operations

|                               |  |  |
|-------------------------------|--|--|
| Effective Date:<br>05/07/1980 | <b>Bypassing of Measuring Stations</b> | Standard Number:<br><b>GS 6400.180(CG)</b><br>P&P 724-18 |
| Supersedes:<br>N/A            |  | Page 4 of 5  |

**EXHIBIT A  
(1 of 2)**

EXAMPLE PROBLEM

Two meters having a maximum capacity of 5000 cfh, meters A and B, are installed in a multiple meter run station that has a bypass. Both meters are to be accuracy tested. The line pressure is 25 psig.

It should first be determined if the station's total delivery can be measured within prescribed maximum rates of flow through a parallel meter. This is accomplished by obtaining the sum of the respective index rates. The known information is the following:

Meter pressure = 25 psig

Index rate of meter A = 2050 cfh

Index rate of meter B = 1950 cfh

Step 1. Calculate the relative density.

$$\text{Relative density} = 0.60 \times \frac{25 + 14.4}{14.4} = 1.64$$

Step 2. Proceed to capacity curve (page 2 of this Exhibit) and at a density of 1.64 locate point A where the density curve intersects the load limiting curve. A horizontal dotted line to the left of point A shows a pressure drop reading of approximately 3.73 inches of water and a vertical line downward from point A reveals a flow rate of 4150 for the 5000 cfh meter.

Step 3. The sum of the index rates for meters A and B (2050 + 1950 = 4000 cfh) is less than 4150 cfh, therefore, the delivery through either meters A or B can be turned off and the total station delivery bypassed through one meter.

Step 4. At 25 psig, the 3,73 inches water column pressure drop was not a problem.

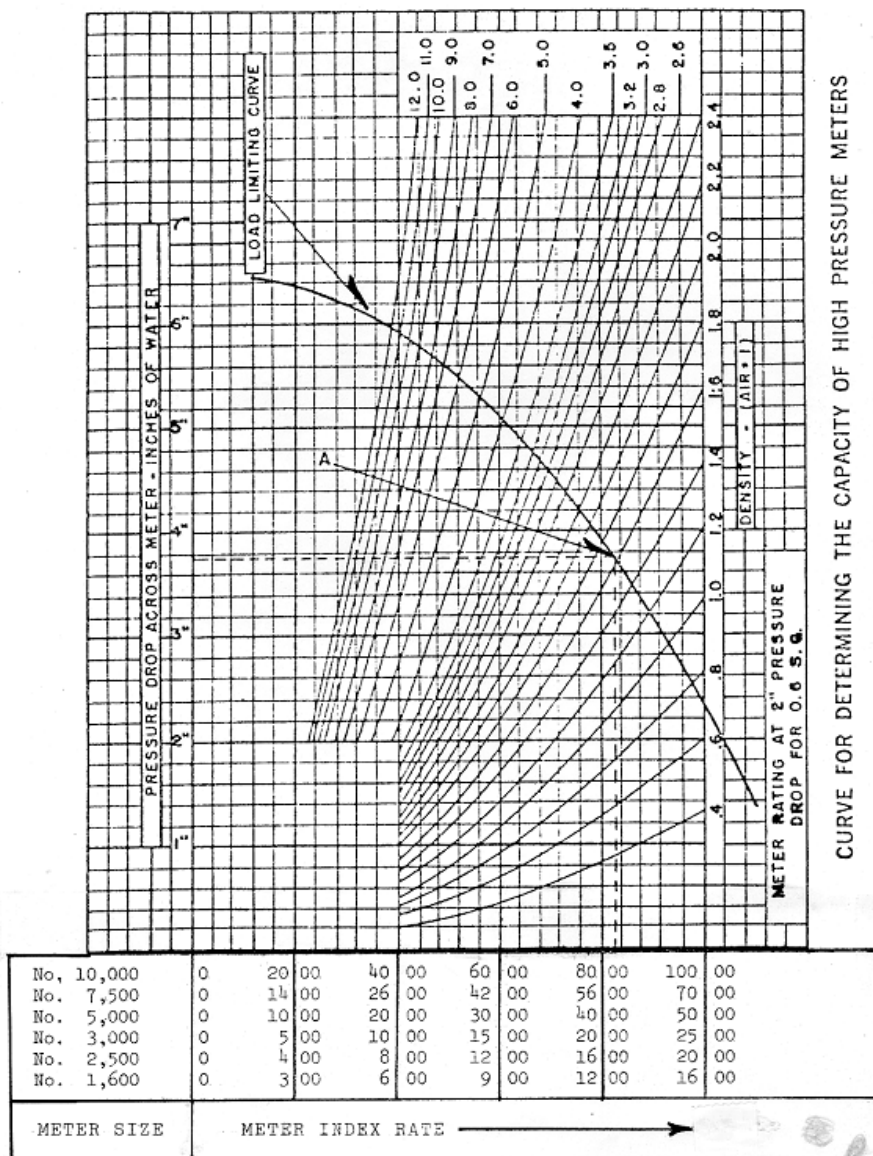


**Gas Standard**

Distribution Operations

|                               |   |  |
|-------------------------------|---|--|
| Effective Date:<br>05/07/1980 | <h2 style="margin: 0;">Bypassing of Measuring Stations</h2> | Standard Number:<br><b>GS 6400.180(CG)</b><br>P&P 724-18 |
| Supersedes:<br>N/A            |   | Page 5 of 5  |

**EXHIBIT A  
(2 of 2)**



CURVE FOR DETERMINING THE CAPACITY OF HIGH PRESSURE METERS



Distribution Operations

|                               |                              |  |
|-------------------------------|------------------------------|--|
| Effective Date:<br>05/18/1994 | <b>Sealing Meter Indexes</b> | Standard Number:<br><b>GS 6400.190(CG)</b><br>P&P 724-19 |
| Supersedes:<br>N/A            |                              | Page 1 of 2  |

Companies Affected:

|                                     |   |   |
|-------------------------------------|---|---|
| <input type="checkbox"/> NIPSCO     | <input checked="" type="checkbox"/> CGV | <input checked="" type="checkbox"/> CMD |
| <input type="checkbox"/> NIFL       | <input checked="" type="checkbox"/> CKY | <input checked="" type="checkbox"/> COH |
| <input type="checkbox"/> Kokomo Gas | <input type="checkbox"/> CMA            | <input checked="" type="checkbox"/> CPA |

**REFERENCE**    None

**1. GENERAL REQUIREMENTS**

A sealed meter index is a deterrent to gas theft and a broken or missing seal provides evidence of possible meter tampering and the altering of registration. All new, repaired or field tested meters shall have the indexes sealed.

Meter Readers, Chart Changers, Service personnel, Measurement and Regulation personnel and others involved with measurement shall report any broken or missing seals or any physical evidence of possible meter tampering to their supervisor for further investigation.

**2. METHODS OF SEALING METER INDEXES**

Only approved seals shall be used for sealing meter indexes. See Material Catalog Groupid M-40.

**2.1 Wire and Seal**

The sealing of a diaphragm meter index shall be accomplished by threading a seal wire through a drilled hole in one of the bolts on the meter hand hole plate and through one or two drilled screws on the meter index cover. The sealing of a rotary or turbine meter index shall be accomplished by threading a seal wire through a drilled hole in a conveniently located meter body bolt and through one or two drilled screws on the meter index cover. In each case, the two ends of the sealing wire shall be threaded through an approved seal, pulled taut then, sealed.

**2.2 Meter Security Seal**

Meter security seals press fit into a special screw retainer collar designed by the meter manufacturer or designed to the manufacturer's specifications.

*This document is considered CONTROLLED only when viewed electronically on the Company's intranet. Printed or other electronic copies may not be current, and the intranet version should be used to verify.*





Distribution Operations

|                               |                              |  |
|-------------------------------|------------------------------|--|
| Effective Date:<br>05/18/1994 | <b>Sealing Meter Indexes</b> | Standard Number:<br><b>GS 6400.190(CG)</b><br>P&P 724-19 |
| Supersedes:<br>N/A            |                              | Page 2 of 2  |

**2.3 Posi-Cap Seal**

A special tool is required to apply the Posi-Cap seal which fits snugly over the screw heads that retain the index cover. Once installed, they cannot be removed without damaging the cap.

**2.4 Putty Seal**

On those meters where the index cover is fastened to the meter with bevel head screws, the screw heads shall be puttied flush and painted.

**2.5 Other Methods of Sealing Meters**

Other methods of sealing meters to prevent meter tampering may be used when approved by Engineering - Measurement and Regulation Manager.





**Gas Standard**

Distribution Operations

|                               |   |  |
|-------------------------------|---|--|
| Effective Date:<br>01/06/1984 | <b>Measuring Station Numbering System - Gas Measurement Billing (GMB)</b> | Standard Number:<br><b>GS 6400.200(CG)</b><br>P&P 724-20 |
| Supersedes:<br>N/A            |   | Page 1 of 3  |

Companies Affected:

|                                     |   |   |
|-------------------------------------|---|---|
| <input type="checkbox"/> NIPSCO     | <input checked="" type="checkbox"/> CGV | <input checked="" type="checkbox"/> CMD |
| <input type="checkbox"/> NIFL       | <input checked="" type="checkbox"/> CKY | <input checked="" type="checkbox"/> COH |
| <input type="checkbox"/> Kokomo Gas | <input type="checkbox"/> CMA            | <input checked="" type="checkbox"/> CPA |

**REFERENCE**    None

**1. GENERAL REQUIREMENTS**

A measurement facility owned by a Columbia Gas Distribution Company shall be assigned a station identification (ID) number. The station ID number is an alpha numeric number which consists of the area ID, alpha prefix, station number, and meter sequence number, e.g., 7-F-4284-1. This number is used by the Finance-Gas Measurement Section to identify the measurement transactions within a station for billing purposes and is used to identify individual meters for the purpose of monitoring compliance with test and inspection schedules, filing, etc.

The “station number” portion of the station ID number is common to all meters within a station and is recorded in the plant accounts and in the continuing property records. It is intended that the station number be applicable for all time to the same meter installation, and that it will remain unchanged, regardless of the number of meter changes, change of customer's name, change of customer, etc. When the entire meter installation is retired, the particular station number will be retired and never be re-issued.

To prevent duplication of station numbers within the Columbia Gas System, the overall control of these station numbers will be with the Finance Department, Gas Measurement Manager, Columbia Gas Transmission Corporation. A block of numbers will be assigned for use by Columbia Gas Distribution Companies upon request from the Supply Planning and Services Department, Measurement and Regulation Manager, Columbia Gas Distribution Companies, to the Finance Department, Gas Measurement Manager, Columbia Gas Transmission Corporation.

**2. ASSIGNMENT OF A NEW MEASURING STATION ID NUMBER**

**2.1 Station Number**

An individual designated by the Supply Planning and Service Department, Measurement and Regulation Manager, assigns the station number when Form C-1459, “Measuring and/or Regulation Station Request,” is submitted. Refer to

*This document is considered CONTROLLED only when viewed electronically on the Company's intranet. Printed or other electronic copies may not be current, and the intranet version should be used to verify.*



Distribution Operations

|                               |   |  |
|-------------------------------|---|--|
| Effective Date:<br>01/06/1984 | <b>Measuring Station Numbering<br/>System - Gas Measurement Billing<br/>(GMB)</b> | Standard Number:<br><b>GS 6400.200(CG)</b><br>P&P 724-20 |
| Supersedes:<br>N/A            |   | Page 2 of 3  |

[GS 6400.100\(CG\)](#) "Measuring and/or Regulation Station Request," for instructions for filling out this form.

**2.2 Area ID Number**

A geographical area ID number is added as a prefix when the station number is assigned and identifies the operating area in which the station is installed. The geographical area ID number will be assigned as follows: the number 6 to identify New York, Pennsylvania and Maryland; the number 7 to identify Ohio; and the number 8 to identify Kentucky, West Virginia and Virginia.

**2.3 Alpha Prefix**

The Finance-Gas Measurement Section assigns the alphabetic character(s), referred to as "alpha prefix," to the station number which shall determine the closing date billing cycle. The Gas Measurement Section provides the assigned "alpha prefix" to the meter inspector and/or area service supervisor after Form CS 6-2-3, "Metering equipment Change Report," and Form C-1275, "Gas Measurement Billing Account Change Request (formerly Excess Pressure Customer Billing Notification)," have been received indicating that a station has been placed in service. Refer to [GS 6400.220\(CG\)](#) "Meter Reading and Chart Changing Schedule -Gas Measurement Billing (GMB)."

**2.4 Meter Sequence Number**

The meter sequence number is assigned as a suffix to the station number by the meter inspector and shall be used to identify the following:

- a. Separate temperature recorders are designated by the meter sequence number "O."
- b. Stations consisting of a single meter run are designated by the meter sequence number "1."
- c. In multiple meter run stations where the meter runs are sequenced "on" or "off" by automatic valves, the pilot meter run (meter run without automatic valve) shall be designated by meter sequence number "1," the first automatic meter run by meter sequence number "2," the second automatic meter run by meter sequence number "3," etc.
- d. In multiple meter run stations without automatic valves and where only one



Distribution Operations

|                               |   |  |
|-------------------------------|---|--|
| Effective Date:<br>01/06/1984 | <b>Measuring Station Numbering<br/>System - Gas Measurement Billing<br/>(GMB)</b> | Standard Number:<br><b>GS 6400.200(CG)</b><br>P&P 724-20 |
| Supersedes:<br>N/A            |   | Page 3 of 3  |

meter has a recording gauge, that meter shall be designated by the meter sequence number "1," the adjacent meter by meter sequence number "2," etc.

In multiple meter run stations without automatic valves and where each meter run has a recording gauge, BPI, BVI, etc. installed, the meter sequence number shall be determined by standing at the inlet riser and facing in the same direction as flow through the meters. The extreme left hand meter shall be designated by meter sequence number "1," and the adjacent meter by meter sequence number "2," etc. The assignment of the meter sequence number using this procedure is not retroactive.

- e. Where auxiliary meters are installed on Sales Accounts, the first auxiliary meter will be designated by meter sequence number "6," the second by meter sequence number "7," etc. Note: An auxiliary meter can be one of the following: (1) a sub meter (deduct meter); (2) an add-on low pressure meter for combined billing; or (3) some other low pressure meter requiring special accounting by the Gas Measurement Billing Section.
- f. Stations not conforming to any of the above situations shall be referred to the Gas Measurement Billing Section.

**3. TAGGING METERS WITH STATION ID NUMBER**

Each meter or meter run in a station shall be identified with its assigned ID number on a tag (metal tag, plastic tag, history card, etc.) attached in a conspicuous location.

**4. RECORDING MEASURING STATION ID NUMBERS ON CHARTS AND FORMS**

The meter inspector/chart changer shall transcribe the station ID number from the tag to the station ID number block provided on the chart(s) (backprinting), record(s) or form(s) which is used to record and report the measurement transactions for the respective meter. The station ID number transcribed shall be verified by the meter inspector/ chart changer while on location to make certain that it has been copied accurately.



Distribution Operations

|                               |  |  |
|-------------------------------|--|--|
| Effective Date:<br>08/03/2009 | <b>Meter Reading and Chart Changing<br/>Schedule - Gas Measurement<br/>Billing (GMB)</b> | Standard Number:<br><b>GS 6400.220(CG)</b><br>P&P 724-22 |
| Supersedes:<br>N/A            |  | Page 1 of 4  |

Companies Affected:

|                                     |   |   |
|-------------------------------------|---|---|
| <input type="checkbox"/> NIPSCO     | <input checked="" type="checkbox"/> CGV | <input checked="" type="checkbox"/> CMD |
| <input type="checkbox"/> NIFL       | <input checked="" type="checkbox"/> CKY | <input checked="" type="checkbox"/> COH |
| <input type="checkbox"/> Kokomo Gas | <input type="checkbox"/> CMA            | <input checked="" type="checkbox"/> CPA |

**REFERENCE**    None

**1. GENERAL REQUIREMENTS**

The Gas Measurement Section assigns the “alpha prefix” to the measuring station number which shall determine the closing date for the billing cycle.

**2. CLOSING DATE SCHEDULE**

**2.1 Closing Date**

The “closing date” is the day of the month, and hour, when applicable, when a meter shall be read and/or a chart changed for the closing of a month's business.

**2.2 Alpha Prefix**

A single alphabetic character referred to as “alpha prefix,” shown in Exhibit A, is an integral part of each measuring station number, i.e., 7-F-4284 (area identification no. - alpha prefix - station number), and identifies the closing date and instructions for meter reading and changing the closing date chart. In cases where two alphabetic characters are used as the “alpha prefix,” i.e., 7-XF-4284, the second alphabetic character shall determine the meter reading and chart changing schedule. The first alphabetic character is used by the Gas Measurement Section to establish an account processing priority.

**3. OTHER THAN CLOSING DATE SCHEDULE**

A 7-day chart changed between the “closing dates” may be scheduled for change at any time suitable to the local area. In no case should these charts remain on the meter in excess of the maximum rotation, i.e., a 7-day chart left on for 8 days, etc. The 31-day charts are excluded from this ruling.

A 31-day meter driven gauge or meter driven/demand type gauge shall not be scheduled for more frequent chart changing than once each billing period except for the following:

*This document is considered CONTROLLED only when viewed electronically on the Company's intranet. Printed or other electronic copies may not be current, and the intranet version should be used to verify.*



Distribution Operations

|                               |  |  |
|-------------------------------|--|--|
| Effective Date:<br>08/03/2009 | <b>Meter Reading and Chart Changing<br/>Schedule - Gas Measurement<br/>Billing (GMB)</b> | Standard Number:<br><b>GS 6400.220(CG)</b><br>P&P 724-22 |
| Supersedes:<br>N/A            |  | Page 2 of 4  |

A 31-day gauge or meter driven/demand type gauge installed on a meter with the alpha prefix "A" through "J" shall have a second chart change in addition to the closing date chart. This chart shall be changed approximately 15 calendar days after the closing chart is removed. In no case shall this chart period exceed 18 days, nor should the scheduled change day of this chart cause the closing date chart period to exceed 18 days. Each area supervisor is responsible for determining the stations affected, and the applicable schedule.

NOTE: Variations of chart changing outside the limits and/or periods specified above will cause delays in processing since closing dates are computer selected.

**4. DAYLIGHT SAVINGS TIME**

Most areas served by Columbia Gas Distribution Companies are in the Eastern Time Zone (designated EST for Eastern Standard Time), and observe the change to Eastern Daylight savings Time (EDT). The first chart to be placed or removed after a time change to or from EDT should be marked appropriately using either "EST" or "EDT."

**5. DISPLACEMENT METER READING AND STATION RECORD**

When displacement or turbine meters are read, the reading and other pertinent information shall be recorded on Form C-926, "Displacement Meter Reading and Station Record," attached as Exhibit B.



Distribution Operations

|                               |  |  |
|-------------------------------|--|--|
| Effective Date:<br>08/03/2009 | <b>Meter Reading and Chart Changing<br/>Schedule - Gas Measurement<br/>Billing (GMB)</b> | Standard Number:<br><b>GS 6400.220(CG)</b><br>P&P 724-22 |
| Supersedes:<br>N/A            |  | Page 3 of 4  |

**EXHIBIT A**

**Alpha Prefixes Used to Establish Meter Reading,  
Chart Changing, and Data Gathering Schedules**

| Alpha Prefix | Closing Date                                | Billing Type                         | Meter Reading and/or Chart Changing Instructions   |
|--------------|---|--------------------------------------|--|
| <b>A</b>     | 1st @ 10:00 A.M.                            | Into Storage                         | Final Billing chart shall be removed on the closing date indicated, or the first day following, should the closing date fall on a weekend or holiday.<br><br>Meter Reading and/or Chart Changing may be performed at any time during the work day AFTER 10:00 A.M. |
| <b>C</b>     | 1st @ 10:00 A.M.                            | Split Daily                          |  |
| <b>F</b>     | 1st @ 10:00 A.M.                            | Special & Inter-Company              |  |
| <b>FF</b>    | 1st @ 10:00 A.M.                            | Special & Inter-Company              |  |
| <b>VG</b>    | 15th @ 10:00 A.M. and 30th or 1st anytime   | Split Daily                          |  |
| <b>UG</b>    | 20th @ 10:00 A.M.                           | Split Daily                          |  |
| <b>H</b>     | 25th @ 10:00 A.M.                           | Split Daily                          |  |
| <b>K</b>     | 25th & 1st @ 10:00 A.M.                     | Dual Purpose                         |  |
| <b>L</b>     | 1st @ 10:00 A.M.                            | Non-Split                            |  |
| <b>M</b>     | End of Month @ 10:00 A.M.                   | Non-Split                            |  |
| <b>N</b>     | 25th @ 10:00 A.M.                           | Non-Split                            |  |
| <b>P</b>     | 20th @ 10:00 A.M.                           | Non-Split                            |  |
| <b>R</b>     | Various                                     | Gas Purchase & Well Measurement Only | Final Billing Chart shall be removed on the first closing date available.<br><br>If the charts are removed on the first day available, they must be removed AFTER 10:A.M.  |
| <b>S</b>     | End of Month (26th to 31st or 25th to 30th) | Non-Split                            |  |
| <b>SS</b>    | End of Month (26th to 31st or 25th to 30th) | Non-Split                            | After 10:00 A.M. on the 20th   |
| <b>T</b>     | 20th  | Non-Split                            |  |
| <b>U</b>     | 15 <sup>th</sup>                            | Non-Split                            |  |
| <b>V</b>     | 10th  | Non-Split                            |  |
| <b>W</b>     | 17th with 4 Days                            | Heater Fuel                          | Final Billing Chart Shall be Removed no earlier than the 13th and no later than the 17th   |
| <b>Y</b>     | Various – Special Needs                     | Split Daily                          | The Gas Measurement Section will forward the schedule to the affected area.  |



Gas Standard

Distribution Operations

|                               |  |  |
|-------------------------------|--|--|
| Effective Date:<br>08/03/2009 | <b>Meter Reading and Chart Changing<br/>Schedule - Gas Measurement<br/>Billing (GMB)</b> | Standard Number:<br><b>GS 6400.220(CG)</b><br>P&P 724-22 |
| Supersedes:<br>N/A            |  | Page 4 of 4  |

**EXHIBIT B**

**COLUMBIA GAS**  
Distribution Companies

Gauge Size & Kind \_\_\_\_\_  
Gauge Range \_\_\_\_\_  
Model Number \_\_\_\_\_

**DISPLACEMENT METER READING  
AND STATION RECORD**

Address \_\_\_\_\_  
City—State \_\_\_\_\_

NAME OF CUSTOMER \_\_\_\_\_  
STATION NUMBER \_\_\_\_\_

| WORK COMPLETED BY (INITIAL) |         | METER KIND AND SIZE |        | METER SERIAL NUMBER |       | METER W. P. |         | VOLUME PER REV./SCALLOP |        | METER SEQ. |       | MCF  |         |      |        |       |       |
|-----------------------------|---------|---------------------|--------|---------------------|-------|-------------|---------|-------------------------|--------|------------|-------|------|---------|------|--------|-------|-------|
| 19                          | READING | REG.                | PRESS. | TEMP.               | INSP. | 19          | READING | REG.                    | PRESS. | TEMP.      | INSP. | 19   | READING | REG. | PRESS. | TEMP. | INSP. |
| JAN                         |         |                     |        |                     |       | JAN         |         |                         |        |            |       | JAN  |         |      |        |       |       |
| FEB                         |         |                     |        |                     |       | FEB         |         |                         |        |            |       | FEB  |         |      |        |       |       |
| MAR                         |         |                     |        |                     |       | MAR         |         |                         |        |            |       | MAR  |         |      |        |       |       |
| APR                         |         |                     |        |                     |       | APR         |         |                         |        |            |       | APR  |         |      |        |       |       |
| MAY                         |         |                     |        |                     |       | MAY         |         |                         |        |            |       | MAY  |         |      |        |       |       |
| JUN                         |         |                     |        |                     |       | JUN         |         |                         |        |            |       | JUN  |         |      |        |       |       |
| JULY                        |         |                     |        |                     |       | JULY        |         |                         |        |            |       | JULY |         |      |        |       |       |
| AUG                         |         |                     |        |                     |       | AUG         |         |                         |        |            |       | AUG  |         |      |        |       |       |
| SEPT                        |         |                     |        |                     |       | SEPT        |         |                         |        |            |       | SEPT |         |      |        |       |       |
| OCT                         |         |                     |        |                     |       | OCT         |         |                         |        |            |       | OCT  |         |      |        |       |       |
| NOV                         |         |                     |        |                     |       | NOV         |         |                         |        |            |       | NOV  |         |      |        |       |       |
| DEC                         |         |                     |        |                     |       | DEC         |         |                         |        |            |       | DEC  |         |      |        |       |       |

|   |   |
|---|---|
| REMARKS:<br>/ = INSP. DUE (RED NUMBERS INDICATE)<br>X = COMPLETED ACCURACY TEST<br>LAST METER INSP. _____ CLASS STATION _____<br>LAST INTER. CAL _____<br>LAST METER PROVER TEST _____<br>LAST OIL CHANGE _____<br>LAST SPIN TEST _____ | LAST LEAKAGE TEST _____<br>LAST FILTER INSP. _____<br>LAST STRAINER INSP. _____ VANES _____<br>LAST STATIC TEST (RPTS.) _____ |
|---|---|

FORM C 526-CSP (8-83)

COLOR - WHITE  
 SIZE - 8-1/2" x 11"  
 FRONT AND BACK SIDE - SAME  
 THREE HOLE PUNCH





Distribution Operations

|                               |   |  |
|-------------------------------|---|--|
| Effective Date:<br>04/15/1981 | <b>Furnishing Gas Estimates for<br/>Billing - Measured Gas Accounting<br/>(MGA)</b> | Standard Number:<br><b>GS 6400.230(CG)</b><br>P&P 724-23 |
| Supersedes:<br>N/A            |   | Page 1 of 5  |

Companies Affected:

|                                     |   |   |
|-------------------------------------|---|---|
| <input type="checkbox"/> NIPSCO     | <input checked="" type="checkbox"/> CGV | <input checked="" type="checkbox"/> CMD |
| <input type="checkbox"/> NIFL       | <input checked="" type="checkbox"/> CKY | <input checked="" type="checkbox"/> COH |
| <input type="checkbox"/> Kokomo Gas | <input type="checkbox"/> CMA            | <input checked="" type="checkbox"/> CPA |

**REFERENCE** None

**1. GENERAL REQUIREMENTS**

In situations where the customer should be made aware that a portion of his bill will be estimated because measuring equipment (meter or auxiliary equipment) has been out of service, or has been registering inaccurately, and the amount of lost (or gained) registration is not determinable by test, previous chart records or equipment reports, the meter inspector shall notify his immediate supervisor and inform him of the reasons. The local Gas Utilization Representative/Industrial Engineer shall be apprised of the problem and provided with the necessary information and assistance that will enable him to develop a practical estimate that can be used to reconcile a billing adjustment to the customer. The meter inspector shall not, as a general rule, contact the customer concerning any gas estimate.

Notification of the Gas Utilization Representative/Industrial Engineer is not required when it is definitely known that gas was not passing during the period in which the metering equipment malfunctioned. In this situation, the meter inspector will note "estimate not required no gas passing" in the Remarks section of the Test Report and when applicable, in the Remarks section of the recording chart or Meter Reading Record.

Notification of the Gas Utilization Representative/Industrial Engineer is not usually (occasionally it may be advisable to have a large estimate verified) required when estimating and reporting bypassed gas and index build-up during routine meter and instrument tests, inspections and repairs (refer to [GS 6400.150\(CG\)](#) "Estimating and Reporting Bypassed Gas and Index Build-Up").

**2. REASONS THAT NECESSITATE A GAS ESTIMATE**

The most common reasons that necessitate a gas estimate, by meter type, are:

**2.1 Diaphragm, Rotary and Turbine Meters**

- a. Malfunctioning equipment, e.g., clock stopped, broken index drive dog, pen(s) failed to record, slippage, incorrect pressure registration, etc.

*This document is considered CONTROLLED only when viewed electronically on the Company's intranet. Printed or other electronic copies may not be current, and the intranet version should be used to verify.*





Distribution Operations

|                               |   |  |
|-------------------------------|---|--|
| Effective Date:<br>04/15/1981 | <b>Furnishing Gas Estimates for<br/>Billing - Measured Gas Accounting<br/>(MGA)</b> | Standard Number:<br><b>GS 6400.230(CG)</b><br>P&P 724-23 |
| Supersedes:<br>N/A            |   | Page 2 of 5  |

- b. Tampering of equipment, e.g., meter, gauge, bypass, etc.

**2.2 Orifice Meters**

- a. Malfunctioning equipment, e.g., clock fast, slow or stopped, pen(s) failed to record, erroneous differential recording due to loss of mercury, automatic chart changer failure, etc.
- b. Gauge left out of service after chart change.
- c. Gauge bypass left open.
- d. Tampering of equipment, e.g., meter, gauge, bypass, etc.

**3. DEVELOPING A GAS ESTIMATE**

Considerations for developing a gas estimate are as follows:

- a. Review the customer's usage and/or production from previous periods and compare them to the current usage and/or production.
- b. Ratio the meter to a parallel meter (Refer to [GS 6400.150\(CG\)](#) "Estimating and Reporting By-passed Gas and Index Build-Up").
- c. Obtain information from customer's check meter or telemetering.
- d. Use degree day deficiency (DDD) information when applicable.

**4. REPORTING PROCEDURE**

The Gas Utilization Representative/Industrial Engineer will submit the gas estimate through channels to the Manager of the Finance-Gas Measurement Section. The meter inspector shall note in the Remarks section of the Test Report (applicable Test Report forms are shown in Exhibits of [GS 6400.150\(CG\)](#) "Estimating and Reporting Bypassed Gas and Index Build-Up") or on an attached page, if more space is required, the following:

- a. The reason for the incomplete or erroneous record and the corrective action taken. All statements of explanation shall be signed by the meter inspector.
- b. Information that will substantiate the development of the gas estimate.

When applicable, the meter inspector shall make a notation in the Remarks section of the recording chart of Meter Reading Record (refer to Exhibits of [GS 6400.140\(CG\)](#) "Mailing of Meter Charts, Records and Reports") relative to the gas estimate and cross reference it to the Test Report. Exhibit A of this procedure shows that Remarks section of a typical



**Gas Standard**

Distribution Operations

|                               |   |  |
|-------------------------------|---|--|
| Effective Date:<br>04/15/1981 | <b>Furnishing Gas Estimates for<br/>Billing - Measured Gas Accounting<br/>(MGA)</b> | Standard Number:<br><b>GS 6400.230(CG)</b><br>P&P 724-23 |
| Supersedes:<br>N/A            |   | Page 3 of 5  |

displacement and orifice meter chart backprinting.

When a chart or a copy of a Test Report indicating a gas estimate is sent to the Finance-Gas Measurement Section for processing, the original of the Test Report sent to the District or Division Service Supervisor shall be noted "CSGM" (Copy Sent to Gas Measurement) or "C&CSGM" (Chart and Copy Sent to Gas Measurement).



**Gas Standard**

Distribution Operations

|                               |  |  |
|-------------------------------|--|--|
| Effective Date:<br>04/15/1981 | <h2 style="margin: 0;">Furnishing Gas Estimates for<br/>                 Billing - Measured Gas Accounting<br/>                 (MGA)</h2> | Standard Number:<br><b>GS 6400.230(CG)</b><br>P&P 724-23 |
| Supersedes:<br>N/A            |  | Page 4 of 5  |

**EXHIBIT A  
 (1 of 2)**

EXHIBIT A  
 Ref. No. 724-23  
 Page 1 of 2

The form is a 'TYPICAL DISPLACEMENT METER CHART BACKPRINTING SHOWING REMARKS SECTION'. It contains the following elements:

- STATION NAME:** A text box for identifying the station.
- STATION NUMBER:** A text box for the station's unique identifier.
- CHART TYPE:** A field with a large number '7' indicating the chart type.
- PLACED BY / RECOVERED BY:** Fields for recording personnel.
- PLACED DATE / RECOVERED DATE:** Fields for recording dates.
- REMARKS:** A large text area for notes.
- READING GRID:** A table with columns for 'P. VALUE', 'T. VALUE', and 'DIFFERENCE'. The grid is divided into two sections, labeled '2' and '9'.

TYPICAL DISPLACEMENT METER CHART  
 BACKPRINTING SHOWING REMARKS SECTION




Distribution Operations

|                               |   |  |
|-------------------------------|---|--|
| Effective Date:<br>04/15/1981 | <b>Furnishing Gas Estimates for<br/>                 Billing - Measured Gas Accounting<br/>                 (MGA)</b> | Standard Number:<br><b>GS 6400.230(CG)</b><br>P&P 724-23 |
| Supersedes:<br>N/A            |   | Page 5 of 5  |

**EXHIBIT A  
 (2 of 2)**

EXHIBIT A  
 Ref. No. 724-23  
 Page 2 of 2



STATION NAME

---

ORIFICE PLATE SIZE: " X "

CHART PLACED BY: \_\_\_\_\_  
 CHART REMOVED BY: \_\_\_\_\_

| CHART TYPE | STATION ID NUMBER |       |                | PLACED |      |      | REMOVED |      |      |
|------------|-------------------|-------|----------------|--------|------|------|---------|------|------|
|            | AREA ID           | ALPHA | STATION NUMBER | MONTH  | DATE | HOUR | MONTH   | DATE | HOUR |
| 63         |                   |       |                |        |      |      |         |      |      |

ORIFICE SIZE: 1

|   | REGISTRATION | TRACE LENGTH OR AVERAGE IN. | PRESSURE VALUE |
|---|--------------|-----------------------------|----------------|
| 1 |              |                             |                |
| 2 |              |                             |                |
| 3 |              |                             |                |
| 4 |              |                             |                |

REMARKS:  


---

---

---

---

---

---

---

---

ORIFICE SIZE: 9

|  | REGISTRATION | TRACE LENGTH OR AVERAGE IN. | PRESSURE VALUE |
|--|--------------|-----------------------------|----------------|
|  |              |                             |                |
|  |              |                             |                |
|  |              |                             |                |
|  |              |                             |                |

TYPICAL ORIFICE METER CHART BACKPRINTING  
 SHOWING REMARKS SECTION



Distribution Operations

|                               |  |  |
|-------------------------------|--|--|
| Effective Date:<br>04/29/1996 | <b>Operation and Maintenance of<br/>Diaphragm Meters</b> | Standard Number:<br><b>GS 6400.240(CG)</b><br>P&P 724-24 |
| Supersedes:<br>N/A            |  | Page 1 of 8  |

Companies Affected:

|                                     |   |   |
|-------------------------------------|---|---|
| <input type="checkbox"/> NIPSCO     | <input checked="" type="checkbox"/> CGV | <input type="checkbox"/> CMD            |
| <input type="checkbox"/> NIFL       | <input checked="" type="checkbox"/> CKY | <input checked="" type="checkbox"/> COH |
| <input type="checkbox"/> Kokomo Gas | <input type="checkbox"/> CMA            | <input type="checkbox"/> CPA            |

REFERENCE ANSI B109.2, "Diaphragm Type Gas Displacement meters (Over 500 Cubic Feet per Hour Capacity)  
Code of Federal Regulations - Title 49 - Part 192 - § 192.605;  
Measurement Information Guide

**1. GENERAL**

General requirements pertaining to location, protection, installation, operation, prevention of accidental ignition and safety precautions for diaphragm meter set assemblies are found in [GS 6400.030\(CG\)](#) "Installation and Operation Requirements for Meter Set Assemblies."

Liquids drained from diaphragm meters shall be collected and disposed of in accordance with [GS 5300.100\(CG\)](#) "Removal of Liquids from Pipelines."

**2. OPERATION**

**2.1 Records**

**2.1.1 Measuring Station Inspection Record**

Form C-3133, "Measuring Station Inspection Record," shall be completed for each Gas Measurement meter and affixed to each meter run so as to be readily available to measurement personnel and others who are responsible for the operation and maintenance of the meter(s). Dates of tests, readings and inspections shall be entered in the appropriate blocks and initialed by the person performing the work.

The Measuring Station Inspection Record is intended to serve as an on-site reference and record for inspections, tests, and required maintenance performed at the measuring stations.

**2.1.2 Meter Reading and Measuring Station Log**

Form C-926, "Meter Reading and Measuring Station Log," may be used by measurement personnel to log pertinent information on each diaphragm meter

*This document is considered CONTROLLED only when viewed electronically on the Company's intranet. Printed or other electronic copies may not be current, and the intranet version should be used to verify.*



Distribution Operations

|                               |  |  |
|-------------------------------|--|--|
| Effective Date:<br>04/29/1996 | <b>Operation and Maintenance of<br/>Diaphragm Meters</b> | Standard Number:<br><b>GS 6400.240(CG)</b><br>P&P 724-24 |
| Supersedes:<br>N/A            |  | Page 2 of 8  |

in a measurement facility and may be used to schedule, plan and record all inspections, tests, required maintenance, chart changing and meter/instrument readings.

**2.2 Minimum Schedule Requirements For Inspecting and/or Testing Diaphragm Meters**

**2.2.1 Customer Accounting Billing (CAB) Customers (Low Pressure Meters)**

Meter change out and on-site testing shall be performed in accordance with [GS 6500.100\(CG\)](#), [GS 6500.100\(KY\)](#), and [GS 6500.100\(VA\)](#) "Changing Meters - Setting New Meters."

**2.2.2 Gas Measurement Customers**

Diaphragm meters and auxiliary equipment shall be tested and/or inspected in accordance with the schedule shown in [GS 6400.110\(CG\)](#) "Schedule for Testing and Inspecting Gas Measurement Facilities."

**2.3 Maximum Operating Tolerances For Diaphragm Meters**

The tolerances of diaphragm meters shall be within the tolerances outlined in [GS 6400.120\(CG\)](#) "Operating and Billing Tolerances for Gas Measurement Equipment." These tolerances shall be in effect except where state regulatory commissions or contract requirements are more stringent. In such instances, the more stringent tolerances shall take precedence. When meters are found to exceed the stated tolerances, they shall be adjusted or repaired to bring them within tolerance. The results shall be reported on the appropriate Gas Measurement DIS Order specified in [GS 6400.130\(CG\)](#) "Gas Measurement Forms and DIS Orders," and the orders executed and filed.

**2.4 Maximum Shop Tolerances For Diaphragm Meters**

All large volume diaphragm meters shall be shop tested prior to installation and adjusted as close as possible to 100% accuracy, never to exceed a maximum tolerance of -0.7% to +0.5% of reference standard at approximately 10% (check), 50% (mid), and 100% (open) of equivalent low pressure rate with a maximum spread between any two test points of 1%.

All new and/or contract repaired domestic diaphragm meters shall be sample tested to assure their accuracy falls within a tolerance of -0.7% to +0.5% of reference standard



Distribution Operations

|                               |  |  |
|-------------------------------|--|--|
| Effective Date:<br>04/29/1996 | <b>Operation and Maintenance of<br/>Diaphragm Meters</b> | Standard Number:<br><b>GS 6400.240(CG)</b><br>P&P 724-24 |
| Supersedes:<br>N/A            |  | Page 3 of 8  |

at approximately 10% (check), 50% (mid), and 100% (open) of equivalent low pressure rate with a maximum spread between any two test points of 1%.

**2.5 Fixed Pressure Factor Measurement**

Fixed Pressure Factor Measurement meters operating at elevated pressures shall be sized and operated in accordance with the specifications in Section 3.5. The inspection and test schedule for the meter and regulator is detailed in [GS 6400.090\(CG\)](#) "Fixed Pressure Factor Metering (FPFM)."

**3. MAINTENANCE**

The testing equipment used to make an inspection or test shall meet the requirements in [GS 6400.110\(CG\)](#) "Schedules for Inspection and Testing of Gas Measurement Facilities." The appropriate Gas Measurement DIS Order in [GS 6400.130\(CG\)](#) "Gas Measurement Forms and DIS Orders," shall be completed and executed for all inspections and/or tests and additional information pertinent to measurement noted in the Remarks section with the corrective action taken, if required.

**3.1 Inspection**

An inspection consists of conducting visual, audible and physical checks on meters, instruments and auxiliary equipment or accessory instrumentation to detect conditions which may have an effect on its continued operation or measurement accuracy. Examples of these checks are: meter properly sized for proper operation, excessive noise, flow pulsation, excessive vibration, unusual movement of the index, meter properly leveled and supported, instrument working properly, bypass closed and sealed, etc.

**3.2 Intermediate Gearing**

At the time of installation or prior to turn-on of a Gas Measurement diaphragm meter, the hand-hole cover (index plate) shall be removed and the intermediate gearing, tangent, linkages, pins and bolts checked to verify that the meter is in proper working condition. The correct intermediate gear ratios for the various kind and size meters are shown in the Measurement Information Guide.

**3.3 Prover Tests**

A Gas Measurement diaphragm meter shall be prover tested at the time of installation, turn on, meter inspections or as soon thereafter as possible in accordance with



Distribution Operations

|                               |  |  |
|-------------------------------|--|--|
| Effective Date:<br>04/29/1996 | <b>Operation and Maintenance of<br/>Diaphragm Meters</b> | Standard Number:<br><b>GS 6400.240(CG)</b><br>P&P 724-24 |
| Supersedes:<br>N/A            |  | Page 4 of 8  |

[GS 6400.110\(CG\)](#) "Schedule for Testing and Inspecting Gas Measurement Facilities."

When a field transfer prover test is performed, an "as found" printout of the detailed test data information shall be filed with the hard copy of the Gas Measurement DIS Order.

### 3.4 Test Flow Rates

Diaphragm displacement meters shall be tested at approximately 10% (check), 50% (mid) and 100% (open) of the maximum rated meter hourly capacity at 2" w.c. differential pressure.

The badge capacity of a diaphragm meter is based upon a gas having a specific gravity of 0.600. When testing with air the index rate should be multiplied by 1.25 to obtain the equivalent low-pressure gas rate.

### 3.5 Reduced Dial Capacity Factor

Diaphragm meter wear is a function of the gas pressure exerted on the valves, diaphragms and other moving parts and the reciprocating or angular velocity at which they are operating. To protect these meters from excess wear and sustain meter accuracy:

- a. the differential pressure across the meter, regardless of the operating pressure, shall be restricted to a 2" w.c. through the application of a reduced dial capacity factor (RDCF), and
- b. the meter shall be sized and operated so that it does not exceed its maximum rated capacity at 2" w.c. at the operating pressure and the maximum delivery rate.

NOTE: The meter can be operated 20% over capacity temporarily to permit continued measurement during a bypassing operation as detailed in [GS 6400.180\(CG\)](#) "Bypassing of Measuring Stations."

### 3.6 Meter Calibration

Meter calibration shall be expressed as a percent of reading at some selected flow rate. The methods of expressing meter calibration are percent proof, percent correction, percent accuracy and percent error.





Distribution Operations

|                               |  |  |
|-------------------------------|--|--|
| Effective Date:<br>04/29/1996 | <h2>Operation and Maintenance of<br/>Diaphragm Meters</h2> | Standard Number:<br><b>GS 6400.240(CG)</b><br>P&P 724-24 |
| Supersedes:<br>N/A            |  | Page 5 of 8  |

**3.6.1 Percent Proof**

The practice of indicating a meter's calibration as "proof" was an expedient method which evolved in the meter shop because:

- a. The volume of gas passed by a meter, represented by whole revolutions of the meter output drive shaft, could be easily observed and directly compared to the volume reading that could be precisely determined from the scale of the bell prover reference standard, and
- b. The proof of a meter produces numbers greater than 100% for slow meters and less than 100% for fast meters, providing a direct multiplication factor for the correction of a customer's bill. Percent proof is defined as:

$$\text{Percent Proof} = \frac{\text{Quantity Indicated by Reference Standard} \times 100}{\text{Quantity Indicated by Meter}}$$

**3.6.2 Percent Correction**

Percent proof is often given in terms of "percent correction," which is defined as:

$$\text{Percent Correction} = \frac{(\text{QI by Meter}) - (\text{QI by Reference Standard}) \times 100}{\text{Quantity Indicated by Meter}}$$

Where: QI = Quantity Indicated

**3.6.3 Percent Accuracy**

When transfer testing a meter on location, calibration is accomplished in terms of percent accuracy, which is defined as:

$$\text{Percent Accuracy} = \frac{\text{Quantity Indicated by Meter}}{\text{Quantity Indicated by Reference Standard}} \times 100$$

**3.6.4 Percent Error**

Percent accuracy is often given in terms of "Percent Error," which is defined as:

$$\text{Percent Error} = \frac{(\text{QI by Meter}) - (\text{QI by Reference Standard}) \times 100}{\text{Quantity Indicated by Reference Standard}}$$



Distribution Operations

|                               |  |  |
|-------------------------------|--|--|
| Effective Date:<br>04/29/1996 | <b>Operation and Maintenance of<br/>Diaphragm Meters</b> | Standard Number:<br><b>GS 6400.240(CG)</b><br>P&P 724-24 |
| Supersedes:<br>N/A            |  | Page 6 of 8  |

Where: QI = Quantity Indicated

Note: As indicated by the equations, percent proof and percent accuracy nearly produce inverse results. For example, 99% accuracy means the meter is 1% slow, whereas 99% proof means the meter is 1% fast. The practice of using percent proof and percent accuracy interchangeably introduces no appreciable error for values near 100%. However, a significant difference appears as the deviation from 100% exceeds 3%.

Percent correction and percent error must carry the correct algebraic sign, either plus (+) or minus (-) to designate if the meter is fast or slow. A summary of meter performance using the four calibration methods is the following:

| <u>Meter Condition</u> | <u>Percent Proof</u> | <u>Percent Correction</u> | <u>Percent Accuracy</u> | <u>Percent Error</u> | <u>Percent Diff.</u> |
|------------------------|----------------------|---------------------------|-------------------------|----------------------|----------------------|
| Slow 110.0             | - 10.0               | 90.9                      | - 9.1                   | 0.9                  |                      |
| Slow                   | 105.0                | - 5.0                     | 95.2                    | - 4.8                | 0.2                  |
| OK                     | 100.0                | 0.0                       | 100.0                   | 0.0                  | 0.0                  |
| Fast                   | 95.0                 | + 5.0                     | 105.3                   | + 5.3                | 0.3                  |
| Fast                   | 90.0                 | + 10.0                    | 111.1                   | + 11.1               | 1.1                  |

**3.7 Testing Temperature Compensated (TC) Meters - Transfer Prover Test**

All transfer provers shall have capabilities to test TC meters. Operation of this feature will correct the volume of the transfer prover reference standard meter to a 60°F base temperature condition. In this case, the gas volume passing through both the transfer prover and the TC meter, have been corrected to a base temperature of 60°F and no temperature correction is required.

**3.8 Liquids in Meters - Gas Measurement Customers**

When a significant amount of liquid is found in a Gas Measurement diaphragm meter, it may cause the meter registration to increase and may eventually cause the meter to malfunction. Where liquid problems are anticipated or exist, the diaphragms and the outer case of the meter shall be provided with drain plugs. It is recommended that the



Distribution Operations

|                               |  |  |
|-------------------------------|--|--|
| Effective Date:<br>04/29/1996 | <b>Operation and Maintenance of<br/>Diaphragm Meters</b> | Standard Number:<br><b>GS 6400.240(CG)</b><br>P&P 724-24 |
| Supersedes:<br>N/A            |  | Page 7 of 8  |

diaphragm drain plugs be broken loose prior to meter installation, then, be re-tightened through the case when the meter is placed in service to assure they are operable.

When the total amount of liquid drained from the diaphragms and chambers of a meter is three (3) quarts or more, the following action shall be taken:

- a. Record the amount found, to the nearest one-half quart, on the appropriate Gas Measurement DIS Order in accordance with [GS 6400.130\(CG\)](#) "Gas Measurement Forms and DIS Orders."
- b. The chart shall be changed, the appropriate back printing information completed and then forwarded to the Engineering - Service Operations - Gas Volume Measurement Section.

**4. BILLING ADJUSTMENTS FOR LIQUIDS IN METERS - GAS MEASUREMENT CUSTOMERS**

The Engineering - Service Operations - Gas Volume Measurement Section shall make the necessary billing adjustments to the meter registration when three (3) or more quarts of liquid are reported in a meter. The graph, "Effect of Liquid on Diaphragm Meter Accuracy by Kind and Size," Exhibit A, shall be used to make this correction.

The meter registration (index buildup or volume passed as determined from a chart) may be adjusted to zero error as follows:

- a. retroactively to the time the error occurred during the current billing period, if the time the error occurred is known; or
- b. retroactively for the current meter index buildup and/or for the period recorded on the chart, if the time the error occurred is unknown.

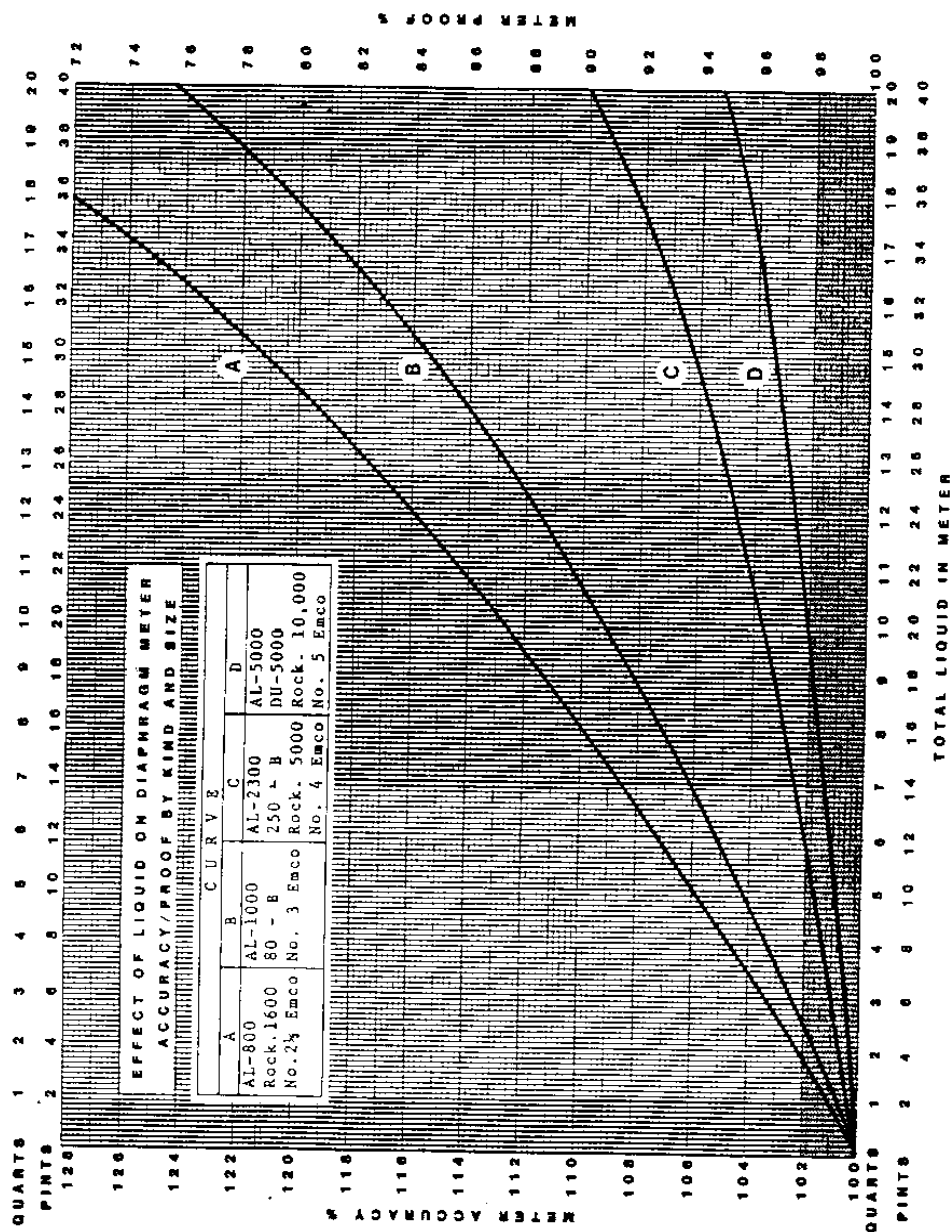
When the above prescribed adjustment procedure conflicts with orders of regulatory bodies having jurisdiction, contract agreements, availability of records, etc., or is not agreed upon by the parties involved, then the method of adjustment shall be mutually agreed upon and applied in a practical manner.



Distribution Operations

|                               |  |  |
|-------------------------------|--|--|
| Effective Date:<br>04/29/1996 | <h2>Operation and Maintenance of Diaphragm Meters</h2> | Standard Number:<br><b>GS 6400.240(CG)</b><br>P&P 724-24 |
| Supersedes:<br>N/A            |  | Page 8 of 8  |

EXHIBIT A





Distribution Operations

|                               |   |  |
|-------------------------------|---|--|
| Effective Date:<br>08/02/2005 | <b>Installation, Operation, and<br/>Maintenance of Rotary-Type Meters</b> | Standard Number:<br><b>GS 6400.250(CG)</b><br>P&P 724-25 |
| Supersedes:<br>N/A            |   | Page 1 of 8  |

Companies Affected:

|                                     |   |   |
|-------------------------------------|---|---|
| <input type="checkbox"/> NIPSCO     | <input checked="" type="checkbox"/> CGV | <input checked="" type="checkbox"/> CMD |
| <input type="checkbox"/> NIFL       | <input checked="" type="checkbox"/> CKY | <input checked="" type="checkbox"/> COH |
| <input type="checkbox"/> Kokomo Gas | <input type="checkbox"/> CMA            | <input checked="" type="checkbox"/> CPA |

**REFERENCE** Columbia Gas Measurement Informational Guide,  
Columbia Gas System - Gas Facilities Committee Document No. 6, ANSI  
B109.3,  
NiSource Distribution Operations-Columbia Gas - Index of Material Standards  
Number 8,  
Code of Federal Regulations - Title 49 - Part 192 - § 192.605

**1. GENERAL REQUIREMENTS**

General requirements pertaining to location, protection, installation, and operation of rotary meter set assemblies are in [GS 6400.030\(CG\)](#), [GS 6400.030\(MD\)](#), and [GS 6400.030\(VA\)](#) "Installation and Operation Requirements for Large Volume CAB and GMB Meter Set Assemblies."

**2. INSTALLATION**

**2.1 Piping**

Both inlet and outlet piping in the same plane as the meter should be of the same nominal pipe diameter (PD) as the meter for at least three (3) PD upstream and (1) PD downstream. A throttling device such as a regulator, valve or flow restriction plate or nozzle should not be installed in close proximity to the meter. Where such installations are necessary, the throttling device should be placed an additional three (3) PD upstream or an additional two (2) PD downstream of the meter. Pipe reductions (increase or decrease) from the throttling device installed in the same plane, as the meter should not be more than (1) nominal pipe size. If an increase of more than one nominal pipe size is required, it shall be accomplished in steps allowing two (2) PD between pipe size changes.

**2.2 Level**

The rotary meter installed either horizontally or vertically shall be level within the tolerances recommended by the manufacturer to assure proper lubrication of the meter bearings.

*This document is considered CONTROLLED only when viewed electronically on the Company's intranet. Printed or other electronic copies may not be current, and the intranet version should be used to verify.*



Distribution Operations

|                               |   |  |
|-------------------------------|---|--|
| Effective Date:<br>08/02/2005 | <b>Installation, Operation, and<br/>Maintenance of Rotary-Type Meters</b> | Standard Number:<br><b>GS 6400.250(CG)</b><br>P&P 724-25 |
| Supersedes:<br>N/A            |   | Page 2 of 8  |

**2.3 Strainers or Filters**

Foreign material shall be removed by blowing down the inlet piping before installing a rotary meter. A strainer or filter shall be installed upstream to protect the meter from foreign particles such as sand, mill scale, valve lubricant, plastic shavings, rust, and welding beads that may be entrained in the gas. A strainer is preferred, but a filter may be substituted if fine particulate matter is present which could pass through a strainer and cause the meter to malfunction.

**2.4 Over-Speed Protection**

Where a meter may be subjected to an over-speed condition because of an on-off, unknown, or varying load condition creating a sudden drop in downstream pressure, a properly sized restricting orifice or flow nozzle shall be installed in the downstream meter piping, but not in the flange adjacent to the meter. The orifice or nozzle shall be sized to restrict the gas flow to the extent that the meter can reach only 120 percent of rated capacity under the operating conditions. This information is available in the "Measurement Informational Guide."

**2.5 Lubrication**

Rotary meters as received from the manufacturer or meter shop are shipped without oil lubricant. This is to prevent oil lubricant from entering the measuring chamber and impairing the meter accuracy or causing the meter to malfunction.

At the time of installation or prior to establishing service to the customer, oil, if required, shall be added to the meter sumps to the level recommended by the manufacturer. Do not overfill as this can cause improper operation of the meter. The grade (viscosity) of oil used shall be in accordance with the specifications recommended by the manufacturer.

Oil shall be drained from a rotary meter removed from service prior to shipping.

**3. OPERATION**

Prior to placing a rotary meter in operation (with meter bolted into the line and before pressurizing), the impellers shall be rotated to assure that they are free to turn. Most meters have access plugs that can be removed and the impellers rotated manually with a wrench (refer to manufacturer's literature).



Distribution Operations

|                               |  |  |
|-------------------------------|--|--|
| Effective Date:<br>08/02/2005 | <h2 style="margin: 0;">Installation, Operation, and<br/>Maintenance of Rotary-Type Meters</h2> | Standard Number:<br><b>GS 6400.250(CG)</b><br>P&P 724-25 |
| Supersedes:<br>N/A            |  | Page 3 of 8  |

**3.1 Records**

The station and meter identification section (top part) of the front side of Form C 3133, "Measuring Station Inspection Record" (see Exhibit A), shall be completed at the time of meter installation or turn-on. The pertinent information in the operating section (bottom part) of the front side of Form C 3133 shall be completed for the date the meter set assembly is placed in service. The date and pertinent information for each inspection, differential pressure test, accuracy test or other required maintenance shall be recorded in the operating section of this form.

The back of the form is used to plot a baseline curve of the meter differential pressure against the index rate. The curve is used to compare the original (baseline) differential pressures to subsequent actual differential pressures obtained during testing. Since the baseline curve will be the most accurate when plotted at the metering pressure, actual readings are preferred. When plotting actual differential pressure readings, obtain the readings soon after installation, and at as many index rates as practical. If it is not practical to obtain actual readings, other reference data may be used, either supplied by the manufacturer or generated through calculation.

NOTE: Differential test data readings for natural gas are lower than those obtained using air. Ensure that data and curves used to compare differential pressures are for, or are corrected for, natural gas.

Once completed, local Operations shall determine where to retain the form. Normal retention could be at the Operations office for CAB customers and at the measuring station for GMB customers.

**3.2 Minimum Schedule Requirements for Meter Inspections and/or Tests**

**3.2.1 Customer Accounting Billing (CAB) Customers**

The frequency of inspections and differential pressure or accuracy tests shall be performed every five (5) calendar years, except where required more frequently by state commission rules as follow:

Kentucky – Deviation granted from 807 KAR 5:022, Section 8 (5) (a)3:  
 "...one-half of its positive displacement meters above 1500 cubic feet per hour on an annual basis."

Pennsylvania – every two (2) calendar years if the meter was installed before January 1, 1990 (PA Code 52.59.21a.2.).





Distribution Operations

|                               |   |  |
|-------------------------------|---|--|
| Effective Date:<br>08/02/2005 | <b>Installation, Operation, and<br/>Maintenance of Rotary-Type Meters</b> | Standard Number:<br><b>GS 6400.250(CG)</b><br>P&P 724-25 |
| Supersedes:<br>N/A            |   | Page 4 of 8  |

Inspection and/or test data shall be recorded on form C 3133 CPS.

**3.2.2 Gas Measurement Billing (GMB) Customers**

The frequency of inspections and differential pressure or accuracy tests shall be in accordance with the schedules shown in Exhibit A of [GS 6400.110\(CG\)](#) "Schedules for Testing and Inspecting Gas Measurement Facilities; Certification and Tolerances for Gas Measurement Testing Equipment."

**3.3 Minimum Schedule Requirements for Auxiliary Equipment Checks, Inspections, and/or Tests**

**3.3.1 CAB Customers - Checking Strainers and Filters**

Strainers/Filters installed on CAB meter set assemblies shall be checked as conditions warrant. Examples of conditions warranting checks include situations when:

- a. work is performed on the distribution system upstream of the strainer/filter,
- b. there are low delivery pressure problems, or
- c. there are recurring problems due to dirty gas.

**3.3.2 GMB Customers**

Refer to [GS 6400.110\(CG\)](#) Exhibit A, for the minimum schedule requirements for inspecting and testing GMB customer rotary meter auxiliary equipment and facilities.

**4. MAINTENANCE**

**4.1 Inspection**

When conducting meter inspections, visible, audible, and physical checks shall be used to perceive changes that may have an adverse effect on the operation or measurement accuracy. Examples of these checks are:

- a. meter properly leveled,
- b. meter properly sized,
- c. excessive noise,





Distribution Operations

|                               |   |  |
|-------------------------------|---|--|
| Effective Date:<br>08/02/2005 | <h2 style="margin: 0;">Installation, Operation, and<br/>                 Maintenance of Rotary-Type Meters</h2> | Standard Number:<br><b>GS 6400.250(CG)</b><br>P&P 724-25 |
| Supersedes:<br>N/A            |   | Page 5 of 8  |

- d. excessive vibration,
- e. condition and level of oil lubricant in sumps,
- f. counter or veeder counter working properly,
- g. index or gauge working properly, and etc.

When these changes are found by the meter inspection, corrective actions shall be taken to ensure the continued operation and measurement accuracy.

**4.2 Differential Pressure Test**

A differential pressure test is a proven method that is used to infer that the original accuracy of a rotary meter has not changed. The differential pressure is the difference in pressure between the inlet and outlet of the meter. The manufacturer provides pressure taps on the meter used for these tests. When the operating test conditions (index rate, pressure, temperature, and specific gravity) are the same and the rotating resistance of the meter has not changed, a differential pressure test point for a given rotary meter is reproducible. Therefore, any observed increase in the differential pressure is a measure of increased rotating resistance in the meter.

A differential pressure test is conducted by obtaining the differential pressure at one or more selected index rates, and comparing it (them) with the baseline differential pressure graphed on the back of Form C 3133 CPS, or to other standard reference data. The differential pressure index rates should be in excess of ten percent (10%) of the rated capacity of the meter. When the differential pressure has increased by 50 percent or more over the baseline differential pressure, corrective action shall be taken to return the meter to the baseline differential pressure. Principal causes of a high differential are valve grease, pipeline dirt, worn bearings, piping strains, or heavy, contaminated, or the incorrect amount of oil. Frequently, the differential pressure can be reduced to a satisfactory level by flushing the meter with an appropriate solvent.

If cleaning (flushing) does not restore the differential pressure to an acceptable level, the meter shall be tested on location, or removed from service and prover-tested in a meter shop using one of the methods indicated in Section 4.4. If the meter size, weight, etc. is such to prohibit removal for any required repairs, the employee performing the differential test shall inform the responsible supervisor of the problem, and a judgment made to enlist factory help or replace the meter.

**4.3 Temperature Compensating (TC) Element**

The rotary meter TC element shall be checked for accuracy at the time of differential



Distribution Operations

|                               |   |  |
|-------------------------------|---|--|
| Effective Date:<br>08/02/2005 | <b>Installation, Operation, and<br/>Maintenance of Rotary-Type Meters</b> | Standard Number:<br><b>GS 6400.250(CG)</b><br>P&P 724-25 |
| Supersedes:<br>N/A            |   | Page 6 of 8  |

test. If the element is found to be more than +/- 5 deg. F. of the test instrument reading, the index unit shall be scheduled for replacement.

**4.4 Prover Test**

When rotary-type meters are required to be tested on location, one or more of the following approved methods may be used:

- a. Transfer meter prover
- b. Flange tap orifice type meter prover
- c. Critical flow orifice/sonic nozzle prover

When proving equipment limits testing of the meter to the badged capacity, tests shall be made up to the capacity of the prover, but not less than the point where the meter accuracy curve becomes flat (where the curve becomes flat can be determined by using a characteristic accuracy curve furnished by the manufacturer for the respective size and model of meter, approximately 10 percent of maximum rated meter capacity).

**4.5 Strainers or Filters**

If there are concerns resulting from operational checks of strainers and filters, they shall be visually inspected.

Strainers are inspected to ensure that they are:

- a. intact,
- b. clear of debris, and
- c. all holes unplugged.

If the integrity of the strainer is suspect, the strainer shall be replaced.

Filters are inspected to ensure that their condition will:

- a. allow the customer to be adequately served,
- b. not distort the gas profile to the meter (nozzle effect), and
- c. not overflow and allow debris to pass that could cause the meter to



Distribution Operations

|                               |   |  |
|-------------------------------|---|--|
| Effective Date:<br>08/02/2005 | <b>Installation, Operation, and<br/>Maintenance of Rotary-Type Meters</b> | Standard Number:<br><b>GS 6400.250(CG)</b><br>P&P 724-25 |
| Supersedes:<br>N/A            |   | Page 7 of 8  |

malfunction.

**4.6 Oil Level and Change Frequency**

Check the oil at every inspection. Add or drain oil as required to maintain the correct level as specified in the manufacturer's literature. As oil is added, allow time for the oil to level off.

Completely change the oil in rotary meters when indicated by the visual condition of the oil.

Meter oil that has been removed shall be handled and disposed of in accordance with [HSE 4400.040\(CG\)](#), [HSE 4400.040\(MD\)](#), or [HSE 4400.040\(PA\)](#) "Hazardous Waste Management."



**Gas Standard**

Distribution Operations

|                               |  |  |
|-------------------------------|--|--|
| Effective Date:<br>08/02/2005 | <h2 style="margin: 0;">Installation, Operation, and<br/>Maintenance of Rotary-Type Meters</h2> | Standard Number:<br><b>GS 6400.250(CG)</b><br>P&P 724-25 |
| Supersedes:<br>N/A            |  | Page 8 of 8  |

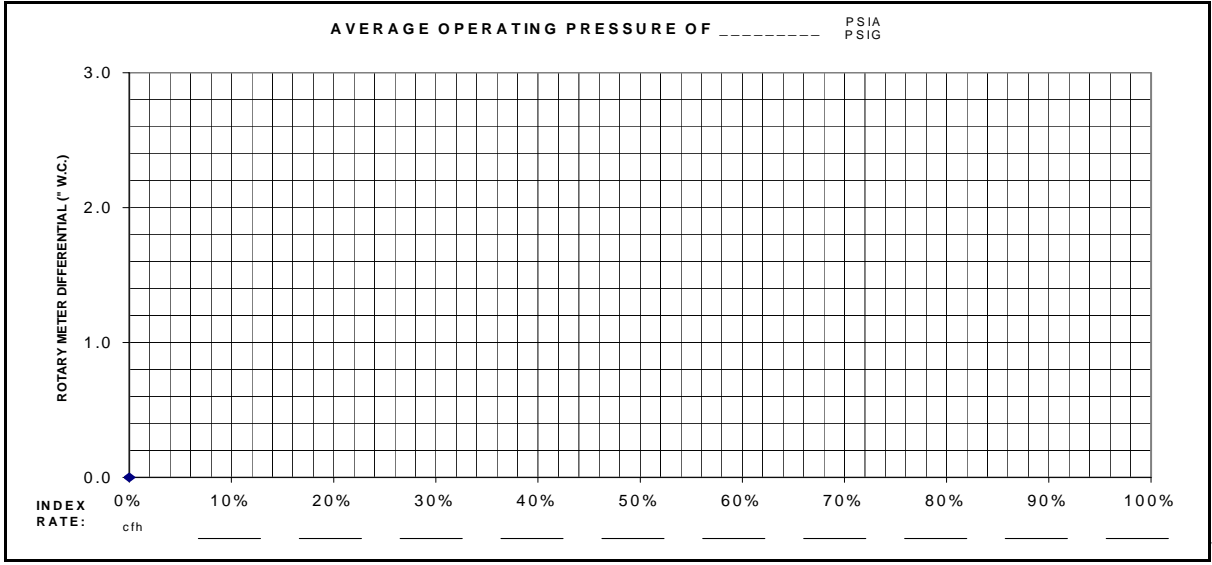
**EXHIBIT A**

Form C 3133, "Measuring Station Inspection Record"  
Color: Buff  
Actual size: 8-1/2" x 5-1/2"

| STATION AND SEQUENCE NO. |                     | MEASURING STATION INSPECTION RECORD |                       |                         |             |                      |  |   |                                 |                                       |                               | PSID NO.                      |                                 |      |  |               |                     |             |          |
|--------------------------|---------------------|-------------------------------------|-----------------------|-------------------------|-------------|----------------------|--|---|---------------------------------|---------------------------------------|-------------------------------|-------------------------------|---------------------------------|------|--|---------------|---------------------|-------------|----------|
| METER SERIAL NUMBER      |                     |                                     |                       | STATION NAME            |             |                      |  |   |                                 | INSTRUMENT MFR., TYPE & SERIAL NUMBER |                               |                               |                                 |      |  |               |                     |             |          |
| METER WORKING PRESSURE   |                     |                                     |                       | INDEX SHAFT CU.FT./REV. |             |                      | CHART ROTATION HRS. <input type="checkbox"/> DAYS <input type="checkbox"/> |   | CHART TYPE                      |                                       | CHART NO. CGS                 |                               |                                 |      |  |               |                     |             |          |
| METER K&S                |                     |                                     |                       | METER K&S CODE          |             | CHART REV OR SCALLOP |  | SCAL <input type="checkbox"/> MCF <input type="checkbox"/> REV <input type="checkbox"/> |                                 | INSTRUMENT PRESSURE RANGE             |                               |                               |                                 |      |  |               |                     |             |          |
| INTERMEDIATE GEAR RATIO: |                     |                                     | LIMIT FLOW CONTROLLER |                         | OPEN INCHES |                      | CLOSE INCHES   |   | INSTRUMENT TEMPERATURE RANGE °F |                                       | PSIA <input type="checkbox"/> | PSIG <input type="checkbox"/> | INCHES <input type="checkbox"/> |      |  |               |                     |             |          |
| DATE                     | INDEX READING (MCF) |                                     |                       | DIAL RATE CFH           |             | PSIG PSIA            |  | TEMP  |                                 |                                       | DIFF.                         |                               | PROVER TEST                     |      |  | OIL CHG./LUB. | FILTER/STRAIN CHECK | VANES INSP. | INSP. BY |
|                          | MECH INDEX          | UNCORR.                             | CORR.                 |                         |             | ACT.                 | MTR  | DIFF.   | ACT.                            | REQ.                                  | DIFF.                         | CHECK                         | MID                             | OPEN |  |               |                     |             |          |
|                          |                     |                                     |                       |                         |             |                      |  |   |                                 |                                       |                               |                               |                                 |      |  |               |                     |             |          |
|                          |                     |                                     |                       |                         |             |                      |  |   |                                 |                                       |                               |                               |                                 |      |  |               |                     |             |          |
|                          |                     |                                     |                       |                         |             |                      |  |   |                                 |                                       |                               |                               |                                 |      |  |               |                     |             |          |
|                          |                     |                                     |                       |                         |             |                      |  |   |                                 |                                       |                               |                               |                                 |      |  |               |                     |             |          |
|                          |                     |                                     |                       |                         |             |                      |  |   |                                 |                                       |                               |                               |                                 |      |  |               |                     |             |          |
|                          |                     |                                     |                       |                         |             |                      |  |   |                                 |                                       |                               |                               |                                 |      |  |               |                     |             |          |
|                          |                     |                                     |                       |                         |             |                      |  |   |                                 |                                       |                               |                               |                                 |      |  |               |                     |             |          |
|                          |                     |                                     |                       |                         |             |                      |  |   |                                 |                                       |                               |                               |                                 |      |  |               |                     |             |          |
|                          |                     |                                     |                       |                         |             |                      |  |   |                                 |                                       |                               |                               |                                 |      |  |               |                     |             |          |
|                          |                     |                                     |                       |                         |             |                      |  |   |                                 |                                       |                               |                               |                                 |      |  |               |                     |             |          |
|                          |                     |                                     |                       |                         |             |                      |  |   |                                 |                                       |                               |                               |                                 |      |  |               |                     |             |          |
|                          |                     |                                     |                       |                         |             |                      |  |   |                                 |                                       |                               |                               |                                 |      |  |               |                     |             |          |

FORM C 3133 (12-04)

(front side)



(back side)



Distribution Operations

|                               |   |  |
|-------------------------------|---|--|
| Effective Date:<br>05/30/1986 | <b>Installation and Operation of<br/>Turbine Meters</b> | Standard Number:<br><b>GS 6400.260(CG)</b><br>P&P 724-26 |
| Supersedes:<br>N/A            |   | Page 1 of 16   |

Companies Affected:

|                                     |   |   |
|-------------------------------------|---|---|
| <input type="checkbox"/> NIPSCO     | <input checked="" type="checkbox"/> CGV | <input type="checkbox"/> CMD            |
| <input type="checkbox"/> NIFL       | <input checked="" type="checkbox"/> CKY | <input checked="" type="checkbox"/> COH |
| <input type="checkbox"/> Kokomo Gas | <input type="checkbox"/> CMA            | <input type="checkbox"/> CPA            |

**REFERENCE** Columbia Gas System Manual of Approved Procedures for Operations, Supplement No. 26, "Gas Measurement - Standards and Calculations." AGA Transmission Measurement Committee Report No. 7, "Measurement of Gas by Turbine Meters."

**1. GENERAL**

Purchase specifications for turbine type meters are found in Material Standards Index No. 8, Section Number 4.

General requirements pertaining to location, protection, installation, operation, prevention of accidental ignition and safety precautions for turbine meter set assemblies are found in [GS 6400.030\(CG\)](#) "Installation and Operation Requirements for Large Volume CAB and GMB Meter Set Assemblies."

Normally, liquids drained from meters and adjacent upstream and downstream piping sections are excluded from regulations governing hazardous waste disposal. Regardless, such liquids shall be collected and disposed of in a manner that will not adversely affect the environment. The hydrocarbon components may be combined with drained waste motor oil or liquid collected from drips or scrubbers, when applicable, which are sold to waste oil recyclers.

**2. INSTALLATION**

**2.1 Piping**

Columbia Gas Distribution Companies' (CDC) standard design drawings of meter set assemblies showing piping configurations, fittings and connections shall be followed, including size and lengths of straight piping, the location of valves, pressure connections, temperature connections, etc.

A throttling device, i.e., a regulator or partially closed valve, should not be installed in the same plane with, or in close proximity to, a turbine meter. When such an

*This document is considered CONTROLLED only when viewed electronically on the Company's intranet. Printed or other electronic copies may not be current, and the intranet version should be used to verify.*



Distribution Operations

|                                       |  |   |
|---------------------------------------|--|---|
| <p>Effective Date:<br/>05/30/1986</p> | <p><b>Installation and Operation of<br/>Turbine Meters</b></p> | <p>Standard Number:<br/><b>GS 6400.260(CG)</b><br/>P&amp;P 724-26</p> |
| <p>Supersedes:<br/>N/A</p>            |  | <p>Page 2 of 16</p>   |

installation is necessary, the facility design will require special consideration and shall be referred to the Engineering Department.

A standard turbine meter installation may be used for any operating pressure and shall be used for all turbine meter installations operating over 200 psig pressure. A short coupled turbine meter installation may only be used for operating pressures 200 psig and below. The installation of a turbine meter in other piping configurations will require special consideration and should be referred to the Engineering Department.

**2.1.1 Standard Turbine Meter Set Assembly**

A standard installation has a straight length of inlet and outlet piping of the same nominal pipe diameter as the meter. The minimum length of the upstream section shall be ten (10) nominal pipe diameters and have straightening vanes installed in the section so that the vane outlet is five (5) nominal pipe diameters from the meter inlet. The minimum length of the downstream section is five (5) nominal pipe diameters. Measurements are made from the face of the respective meter flange.

The meter, including the upstream and downstream sections, is connected to vertical meter risers using a standard tee or elbow. The maximum tee or elbow reduction to the risers shall not be more than one (1) nominal pipe diameter.

Valving may be installed in the risers. A strainer or filter shall be installed in the upstream riser between the valve and the tee or elbow. A strainer may be installed in the upstream tee, provided it does not distort the velocity profile or create jetting or swirling of the gas stream that would affect meter accuracy.

**2.1.2 Short Coupled Turbine Meter Set Assembly**

A short coupled installation shall have a straight length of inlet piping of the same nominal pipe diameter as the meter. The minimum length of the upstream section shall be four (4) nominal pipe diameters and have straightening vanes located in the section so that the vane outlet is a minimum of two (2) nominal pipe diameters from the meter inlet. No downstream pipe section is required. Measurements for the upstream section are made from the face of the upstream meter flange.

The meter and upstream section is connected to vertical meter risers using a standard tee or elbow. The maximum tee or elbow reduction to the risers shall not be more than one (1) nominal pipe diameter.



Distribution Operations

|                               |  |  |
|-------------------------------|--|--|
| Effective Date:<br>05/30/1986 | <h2 style="margin: 0;">Installation and Operation of<br/>Turbine Meters</h2> | Standard Number:<br><b>GS 6400.260(CG)</b><br>P&P 724-26 |
| Supersedes:<br>N/A            |  | Page 3 of 16   |

Valving may be installed in the risers. A strainer or filter shall be installed in the upstream riser between the valve and the tee or elbow. A strainer may be installed in the upstream tee provided it does not distort the velocity profile or create jetting or swirling of the gas stream that would affect meter accuracy.

### 2.2 Straightening Vanes

Straightening vanes shall be installed in the upstream piping to a turbine meter at the locations indicated in section 2.1.1 and 2.1.2. The construction of the straightening vanes shall be consistent with the specifications for straightening vanes detailed in ANSI/API 2530, "Orifice Metering of Natural Gas."

### 2.3 Strainers or Filters

To prevent serious damage to a turbine meter that can be caused by foreign substances (distillates, stones, weld beads, etc.) in a pipe line, a basket type strainer shall be installed upstream of the meter inlet piping. The strainer shall be sized (the hole diameter shall not be greater than 3/16 inch and the total area of the holes shall be equal to 120 to 150 percent of the pipe area) so that at maximum flow there is a minimum pressure drop and flow distortion.

If a greater degree of meter protection is required, as an option to installing a strainer, a dry-type filter may be installed in the upstream meter riser piping. It is recommended that the differential pressure across a filter be monitored to maintain it in good condition so as to prevent flow distortion and possible customer outage.

### 2.4 Overspeed Protection

Sudden rotor overspeeding caused by extreme gas velocities encountered during pressuring, depressuring or purging can cause severe damage to a turbine meter. The sizing of a blow down valve shall be in accordance with [GS 6400.030\(CG\)](#) Section 4.9.

When a meter may be subjected to an overspeed condition because of an on-off, unknown or varying load condition creating a sudden drop in downstream pipeline pressure, a properly sized critical flow orifice or sonic venturi nozzle may be installed in the piping downstream of the meter (five pipe diameters for standard setting; at some location past the tee or elbow for short coupled setting) and should be sized to limit the meter to approximately 120% of its maximum rated capacity. A critical flow orifice so sized will result in a 50% permanent pressure loss and a sonic venturi nozzle will result in a 10-20% permanent pressure loss at the limiting operating conditions. Sizing



Distribution Operations

|                               |   |  |
|-------------------------------|---|--|
| Effective Date:<br>05/30/1986 | <b>Installation and Operation of<br/>Turbine Meters</b> | Standard Number:<br><b>GS 6400.260(CG)</b><br>P&P 724-26 |
| Supersedes:<br>N/A            |   | Page 4 of 16   |

information is available in the manufacturer's published literature.

**2.5 Pulsation Effect**

The installation of a turbine meter near a compressor or fast cycling regulators that produce rapid flow pulsations (gas compression and rarification) may cause significant pulsation induced measurement error. The problem may be lessened to a large degree by placing the meter farther from the pulsation source or by installing a pulsation dampener. When the problem can be anticipated, it is recommended that the manufacturer be contacted by the Engineering Department for their recommendations and possible solutions.

**2.6 Additional Installation Requirements**

- a. The meter and meter piping shall be installed so as to reduce strain due to pipeline stresses.
- b. A concentric alignment of the companion pipe flanges with the meter inlet and outlet connections shall be obtained.
- c. A gasket protrusion into the bore or flow pattern at the meter inlet or outlet connections shall not be permitted.
- d. The interior of connecting pipe shall be of commercial roughness, and the flange I.D. shall be the same as that of the pipe. Welds on piping at the meter inlet and outlet shall be ground to the I.D. of the pipe.
- e. Installations where liquids can be anticipated shall be designed to prevent liquid accumulation in the meter.
- f. Installations where large reductions in gas pressure can be anticipated shall be designed to prevent the formation of ice and/or hydrates in the meter set assembly. Where this condition may exist, consideration should be given to the installation of drips, scrubbers, catalytic heaters, inline gas fired heaters or the injection of alcohol.
- g. When welding on piping adjacent to the meter, the meter shall be removed to prevent possible internal damage.





Distribution Operations

|                               |   |  |
|-------------------------------|---|--|
| Effective Date:<br>05/30/1986 | <b>Installation and Operation of<br/>Turbine Meters</b> | Standard Number:<br><b>GS 6400.260(CG)</b><br>P&P 724-26 |
| Supersedes:<br>N/A            |   | Page 5 of 16   |

**2.7 Meter Pressure Sensing Location**

The upstream pressure tap provided by the manufacturer on the meter body shall be used as the point to sense the meter pressure for recording or integrating instruments.

**2.8 Meter Temperature Sensing Location**

The temperature sensed at the temperature wells should represent as accurately as possible the gas flowing temperature at the location of the meter rotor. The thermometer wells (gauge well and test well) should be installed so that the sensed temperature is not influenced by heat transfer from the piping and well attachment and located so as to not reflect flow disturbances upstream that would affect the accuracy of the meter.

**2.8.1 Standard Turbine Meter Set Assembly**

The gauge temperature well shall be installed two (2) nominal pipe diameters downstream as measured from the face of the outlet meter flange. The temperature test well shall be installed as close as possible downstream of the gauge temperature well.

**2.8.2 Short Coupled Turbine Meter Set Assembly**

The gauge temperature well and the temperature test well shall be located in the downstream tee or elbow.

**2.9 Accessory Instrumentation Torqueing Requirements**

In order to maintain the manufacturer's specified meter accuracy, the total torque required to drive accessory instrumentation (mechanical and/or electrical) installed on a turbine meter shall not exceed 2 inch-ounces. If the torque requirement of the accessory equipment is not easily ascertainable, the manufacturer shall specify the torque required prior to use of the equipment. Higher torque values may degrade the meter accuracy at low flows, cause considerable error on off-on type flows, and accelerate gear train wear. The spin test time detailed in Section 4.5 would indicate torque values that exceed the above requirements.

**3. OPERATION**

Prior to the initial placing of a turbine meter in service, the metering module shall be removed and given a spin test to assure that the meter is operating satisfactorily.



Distribution Operations

|                               |   |  |
|-------------------------------|---|--|
| Effective Date:<br>05/30/1986 | <b>Installation and Operation of<br/>Turbine Meters</b> | Standard Number:<br><b>GS 6400.260(CG)</b><br>P&P 724-26 |
| Supersedes:<br>N/A            |   | Page 6 of 16   |

For maximum life and sustained accuracy, turbine meters should be operated within their specified flow range. Overspeeding the rotor can cause premature wearing of the internal parts and damage to the rotor. Turbine meters are capable of operating at modest overloads for short periods, as indicated in [GS 6400.180\(CG\)](#) "Bypassing of Measuring Stations," but continued overloading shall be avoided by proper meter sizing.

**3.1 Records**

**3.1.1 Form CS 6-203, Displacement Meters**

The station name (customer name, account number, and address) and meter identification section for Form CS 6-203, Exhibit A, shall be completed at the time of meter installation or turn-on.

Form CS 6-203 shall be filed on each meter run where it will be readily available to the meter inspector and others who are responsible for the operation and maintenance of the meter. The dates and readings when spin tests and inspections were made shall be entered in the appropriate blocks and initialed by the person performing the work.

**3.1.2 Test Data Sheet**

The manufacturer's Test Data Sheet, Exhibit B, which accompanies each new meter showing the factory accuracy of the turbine meter/module and the spin time, shall be filed at the CDC meter shop which has the responsibility of recertifying the accuracy of the module.

When a turbine meter module is returned to the meter shop for repair, it shall be spin tested and in-tested as soon as possible. This data and other pertinent information (day, person conducting test, prover number, etc.) shall be filed at the meter shop.

When a turbine meter module is repaired and recertified, a new Test Data Sheet shall be completed and filed at the meter shop.

The meter shop shall affix a tag to each turbine meter/module, showing the spin time.

**3.1.3 Form C-926, "Displacement Meter Reading and Station Record"**

Form C-926, Exhibit C, shall be used by the meter inspector to log pertinent



Distribution Operations

|                               |   |  |
|-------------------------------|---|--|
| Effective Date:<br>05/30/1986 | <b>Installation and Operation of<br/>Turbine Meters</b> | Standard Number:<br><b>GS 6400.260(CG)</b><br>P&P 724-26 |
| Supersedes:<br>N/A            |   | Page 7 of 16   |

information on each turbine meter in a measurement facility. The date and meter reading shall be recorded on this form each time a meter is inspected, spin tested, filter/strainer inspected, gauge tested, etc. Form C-926 is used to forecast and schedule the required meter maintenance.

**3.2 Minimum Schedule Requirements for Inspecting and/or Testing Turbine Meters**

**3.2.1 Customer Accounting Billing (CAB) Customers**

After the meter has been placed in service for three months, an inspection and spin test shall be performed to assure that the meter is operating properly. Subsequently, the frequency of inspections and spin tests or accuracy tests shall be in accordance with the rules and regulations of the state regulatory commission. In the absence of a direct reference to turbine meters in state regulations, the meter shall be inspected and a spin test made every two years or more often if warranted by operating conditions.

Inspection and/or test data shall be recorded on Form CS6-183, "Meter Test Report (As found) - Transfer Prover," or CS6-21, "Meter Test Report (As found) - Orifice Prover." These forms are found in [GS 6400.130\(CG\)](#) "Maintaining District Meter Reports - Gas Measurement Billing (GMB)." Pertinent inspection and/or test information shall be transcribed to Form CS 6-203 and Form C 926, then the Meter Test Report shall be filed at the Area Office (location where meter records will be posted, reviewed, and filed) or the location specified by the District Service Manager.

**3.2.2 Gas Measurement Billing (GMB) Customers**

Turbine meters and auxiliary equipment shall be inspected and/or tested in accordance with the schedule shown in [GS 6400.110\(CG\)](#) "Program for Testing and Inspecting Meters and Other Gas Measurement Equipment for Measured Gas Accounting (MGA) System Customers."

Inspection and/or test data shall be recorded on the appropriate forms, either CS6-183, CS6-21, or CS6-23. These forms are found in [GS 6400.130\(CG\)](#) "Maintaining District Meter Reports - Gas Measurement Billing (GMB)." Pertinent inspection and/or test information shall be transcribed to Form CS 6-203 and Form C-926, then the Meter Test Report shall be filed at the Area Office (location where meter records will be posted, reviewed, and filed) or the location specified by the District Service Manager.



Distribution Operations

|                               |   |  |
|-------------------------------|---|--|
| Effective Date:<br>05/30/1986 | <b>Installation and Operation of<br/>Turbine Meters</b> | Standard Number:<br><b>GS 6400.260(CG)</b><br>P&P 724-26 |
| Supersedes:<br>N/A            |   | Page 8 of 16   |

**3.3 Minimum Schedule Requirements for Inspecting and Testing Turbine Meter Auxiliary Equipment and Facilities - GMB Customers**

Refer [GS 6400.110\(CG\)](#) Exhibit C, for the minimum schedule requirements for inspecting and testing GMB customer turbine meter auxiliary equipment and facilities.

**3.4 Maximum Operating Tolerances for Turbine Meters and Auxiliary Equipment**

**3.4.1 Customer Accounting Billing (CAB) Customers**

The maximum operating tolerance for turbine meters shall be in accordance with the rules and regulations of the state regulatory commission. In the absence of a direct reference to turbine meters in state regulations, the meter tolerance shall be the same as that for a GMB meter.

**3.4.2 Gas Measurement Billing (GMB) Customers**

Refer to Exhibit A of [GS 6400.120\(CG\)](#) "Operating and Billing Tolerances for Meters and Auxiliary Measurement Equipment - Gas Measurement Billing (GMB)," for maximum operating tolerances for turbine meters and auxiliary equipment.

**4. INSPECTION AND/OR TESTS**

The testing equipment used to make an inspection or test shall meet the requirements in [GS 6400.110\(CG\)](#) "Schedule for Inspection and Testing of Gas Measurement Facilities."

**4.1 Inspection**

An inspection is the conducting of visual, audible and physical checks on a meter or accessory instrumentation to detect conditions which may have an affect on its continued operation or measurement accuracy. Examples of these checks are: meter properly sized, excessive noise, excessive vibration, unusual movement of the index, instrumentation working properly, bypass closed and sealed, etc.

**4.2 Prover Tests**

When turbine meters are required to be tested to determine their accuracy, one of the following methods shall be used:

- a. Rotary or turbine transfer meter prover.



Distribution Operations

|                               |   |  |
|-------------------------------|---|--|
| Effective Date:<br>05/30/1986 | <b>Installation and Operation of<br/>Turbine Meters</b> | Standard Number:<br><b>GS 6400.260(CG)</b><br>P&P 724-26 |
| Supersedes:<br>N/A            |   | Page 9 of 16   |

- b. Flange tap orifice type meter prover.
- c. Critical flow orifice/sonic nozzle prover.

Turbine meters shall be tested at approximately 10%, 50%, and 80% of the maximum rated hourly capacity. When proving equipment does not permit testing of the meter to the maximum capacity, tests shall be made to the capacity of the prover, but not less than the point where the accuracy curve becomes flat or maintains a slight slope, compared to the manufacturer's accuracy curve.

**4.3 Meter Calibration**

Meter calibration shall be expressed as a percent of reading at a selected flow rate. The two methods of expressing turbine meter calibration are percent accuracy and percent error. Both methods are defined in [GS 6400.240\(CG\)](#) "Operation of Large Volume Diaphragm Meters."

**4.4 Metering Module Interchange**

Based on turbine meter manufacturer's tests, performance and accuracy are not adversely affected when interchanging the metering module from one meter body to another (like kind, size and model) when installed in either a standard or short coupled meter set assembly. Therefore, when on-site prover testing is not economical or feasible, modules shall be pre-tested at a central location under controlled conditions and used to replace modules that are due for change-out on a scheduled basis or ones that have been damaged or are in need of repair.

The accounting to the meter shop for turbine meter modules which are removed or installed shall be accomplished using a meter record card. The procedure for handling the meter record card is detailed in [GS 6400.070\(CG\)](#) "Meter Records."

**4.4.1 Customer Accounting Billing (CAB) Customers**

Meter module change out shall be in accordance with [GS 6500.100\(CG\)](#), [GS 6500.100\(KY\)](#), and [GS 6500.100\(VA\)](#) "Changing Meters."

Meter modules intested by the meter shop that may require an adjustment shall be reported and handled in accordance with [GS 6400.070\(CG\)](#).



Distribution Operations

|                               |   |  |
|-------------------------------|---|--|
| Effective Date:<br>05/30/1986 | <b>Installation and Operation of<br/>Turbine Meters</b> | Standard Number:<br><b>GS 6400.260(CG)</b><br>P&P 724-26 |
| Supersedes:<br>N/A            |   | Page 10 of 16  |

**4.4.2 Gas Measurement Billing (GMB) Customers**

A Metering Equipment Change Report (MECR), Form CS6-2-3, shall be completed for the removed and installed turbine meter modules for GMB accounts. The completion and routing of this form is detailed in [GS 6400.170\(CG\)](#) "Metering Equipment Change Report (MECR) - Gas Measurement Billing (GMB)."

The results of meter modules in-tested by the meter shop shall be reported monthly on form, Report of In-test Results of Gas Measurement Meters, with copies sent to the Finance - Gas Measurement Section for the necessary billing adjustments and filing and to the Measurement and Regulation Advisors for review and filing.

**4.5 Spin Time Test**

A spin time test shall be performed to ascertain the mechanical freeness of the metering module and the instrumentation (mechanical and/or electrical). The spin time shall be within the manufacturer's specified minimum spin times for the kind, size, and model of the meter. If the spin time is less, remove the instrumentation and repeat the test.

If the minimum spin time of the meter module without instrumentation cannot be obtained, it shall be changed out.

If the minimum spin time of the meter module with instrumentation installed cannot be obtained, the instrumentation shall be checked and the problem corrected. Those cases involving excessive instrument torqueing (refer to section 2.8) shall be referred to the Engineering Department, Manager of Measurement and Regulation.

**5. CALCULATION OF MAXIMUM AND MINIMUM CAPACITY RATING**

The maximum rated capacity of a turbine meter is limited to a flow rate that will not exceed a specified rotor speed in rpm. This maximum rotor speed remains the same regardless of the pressure. The maximum rated capacity is generally related to 4 ounces inlet pressure and approximately 1.5" w.c. differential pressure between the inlet and outlet of the meter referred to a 14.73 psia base pressure and a 60°F base temperature.

The maximum capacity of a turbine meter at a specified operating pressure shall be calculated using the following formula:



Distribution Operations

|                               |   |  |
|-------------------------------|---|--|
| Effective Date:<br>05/30/1986 | <b>Installation and Operation of<br/>Turbine Meters</b> | Standard Number:<br><b>GS 6400.260(CG)</b><br>P&P 724-26 |
| Supersedes:<br>N/A            |   | Page 11 of 16  |

$$Q_{bmax} \text{ (Scfh)} = Q_{rmax} \times \frac{P_f + 14.4}{14.73} \times \frac{520}{460 + t_f} \times (F_{pv})^2$$

The minimum flow rate for a turbine meter at a specified operating pressure is the lowest flow rate at which the meter will operate within an accuracy limit of approximately + 1.0%.

$$Q_{bmin} \text{ (Scfh)} = Q_{rmin} \times \frac{P_f + 14.4}{14.73} \times \frac{520}{460 + t_f} \times \frac{0.600}{G} \times (F_{pv})^2$$

Where:

$Q_{rmax}$  = Manufacturer's published maximum index hourly flow rate at normal distribution pressure of 7" w.c. (0.25 psig), a flowing temperature of 60°F, and a specific gravity of 0.600.

$Q_{bmin}$  = Manufacturer's published minimum index hourly flow rate at normal distribution pressure of 7" w.c. (0.25 psig), a flowing temperature of 60°F, and a specific gravity of 0.600.

$P_f$  = Meter gauge pressure, (psig)

$t_f$  = Flowing gas temperature, °F

$F_{pv}$  = Supercompressibility factor for the operating pressure, temperature and gravity.

**6. CALCULATION OF CORRECTED GAS VOLUMES**

Corrected gas volumes shall be calculated for turbine meters operating above normal distribution pressure (7" w.c.) using the following formula, except meters equipped with a mechanical or electrical accessory instrumentation which adjusts the uncorrected meter registration for metering pressure, temperature and gas supercompressibility.

The turbine meter index difference is converted to a standard gas volume in Mscf at specified base pressure and temperature conditions, using the following formula:

$$Mscf = \text{Index Difference} \times \frac{P_f}{P_b} \times \frac{T_b}{T_f} \times (F_{pv})^2_f$$



Distribution Operations

|                               |   |  |
|-------------------------------|---|--|
| Effective Date:<br>05/30/1986 | <b>Installation and Operation of<br/>Turbine Meters</b> | Standard Number:<br><b>GS 6400.260(CG)</b><br>P&P 724-26 |
| Supersedes:<br>N/A            |   | Page 12 of 16  |

$$P_b \quad T_f$$

Where:

Mscf = One thousand standard cubic feet

Index = End reading minus beginning reading in Mcf at line conditions

Difference

$P_f$  = Static pressure at meter, psia

$P_b$  = Contract pressure base, psia

$T_f$  = Gas flowing temperature at meter, degrees Rankine

$T_b$  = Contract temperature base, degrees Rankine

$(F_{pv})_{2f}$  = Supercompressibility factor at metering conditions squared.

Each factor and the product thereof, after each multiplication, shall be rounded to 4 decimal places. The rounding procedure shall be that of raising by one the last digit to be retained, if the following digit is a 5 or greater.

For manual calculations, values of the pressure multiplier  $\frac{P_f}{P_b}$  and

the temperature multiplier  $\frac{T_b}{T_f}$  are shown in the Manual of Approved

Procedures for Operations, Supplement No. 26, "Gas Measurement - Standards and Calculations." For computer calculation, values for the pressure and temperature multipliers shall be computed directly. Average static pressure shall be determined for each volume calculation time interval. Flowing gas temperatures shall be determined from either:

- a. An indicating thermometer or recording temperature instrument.
- b. Specific contracts, tariffs, etc.
- c. Monthly Average Gas Temperatures for Appalachian Area (Supplement No. 26).





Distribution Operations

|                               |   |  |
|-------------------------------|---|--|
| Effective Date:<br>05/30/1986 | <b>Installation and Operation of<br/>Turbine Meters</b> | Standard Number:<br><b>GS 6400.260(CG)</b><br>P&P 724-26 |
| Supersedes:<br>N/A            |   | Page 13 of 16  |

Specific gravity shall be determined by either:

- a. indicating or recording gravitometer
- b. selected or established values of specific gravity (e.g. 0.600)
- c. calculation from the result of a compositional analysis

Supercompressibility factors  $(F_{pv})_2$  shall be determined as shown in Supplement No. 26.

Note: For computer programming, it may be necessary to alter the order of multiplication and to truncate rather than round after inter-mediate multiplication. The factors found in Supplement No. 26 may not agree exactly with computer calculation since the computer calculations do not have table interpretation as sometimes required in the table look-up method



**Gas Standard**

Distribution Operations

|                               |  |  |
|-------------------------------|--|--|
| Effective Date:<br>05/30/1986 | <h2 style="margin: 0;">Installation and Operation of<br/>Turbine Meters</h2> | Standard Number:<br><b>GS 6400.260(CG)</b><br>P&P 724-26 |
| Supersedes:<br>N/A            |  | Page 14 of 16  |

**.EXHIBIT A**

| DATE | READING | METER TEST | GAUGE TEST | DIFF. TEST | SPIN TEST | INSP. BY |
|------|---------|------------|------------|------------|-----------|----------|
|      |         |            |            |            |           |          |
|      |         |            |            |            |           |          |
|      |         |            |            |            |           |          |
|      |         |            |            |            |           |          |
|      |         |            |            |            |           |          |
|      |         |            |            |            |           |          |
|      |         |            |            |            |           |          |
|      |         |            |            |            |           |          |
|      |         |            |            |            |           |          |
|      |         |            |            |            |           |          |
|      |         |            |            |            |           |          |
|      |         |            |            |            |           |          |
|      |         |            |            |            |           |          |
|      |         |            |            |            |           |          |
|      |         |            |            |            |           |          |
|      |         |            |            |            |           |          |
|      |         |            |            |            |           |          |
|      |         |            |            |            |           |          |
|      |         |            |            |            |           |          |
|      |         |            |            |            |           |          |
|      |         |            |            |            |           |          |

FORM Cs 6-209 CSD

COLUMBIA GAS SYSTEM  
**DISPLACEMENT METERS**

STA. NAME \_\_\_\_\_

STA. & SEQ. NO. \_\_\_\_\_ SER. NO. \_\_\_\_\_

MTR. KIND & SIZE \_\_\_\_\_ CHART NO. \_\_\_\_\_

GAUGE RANGE \_\_\_\_\_ MCF PER SCALLOP \_\_\_\_\_

MCF PER REV. \_\_\_\_\_

LIMIT FLOW CONTROLLER - OPEN \_\_\_\_\_ CLOSE \_\_\_\_\_

(Check (✓) as applicable)

| DATE | READING | METER TEST | GAUGE TEST | DIFF. TEST | SPIN TEST | INSP. BY |
|------|---------|------------|------------|------------|-----------|----------|
|      |         |            |            |            |           |          |
|      |         |            |            |            |           |          |
|      |         |            |            |            |           |          |
|      |         |            |            |            |           |          |
|      |         |            |            |            |           |          |
|      |         |            |            |            |           |          |
|      |         |            |            |            |           |          |
|      |         |            |            |            |           |          |
|      |         |            |            |            |           |          |
|      |         |            |            |            |           |          |
|      |         |            |            |            |           |          |
|      |         |            |            |            |           |          |
|      |         |            |            |            |           |          |
|      |         |            |            |            |           |          |
|      |         |            |            |            |           |          |
|      |         |            |            |            |           |          |
|      |         |            |            |            |           |          |
|      |         |            |            |            |           |          |
|      |         |            |            |            |           |          |
|      |         |            |            |            |           |          |
|      |         |            |            |            |           |          |
|      |         |            |            |            |           |          |

Color - White  
 Size - 4 1/2" x 3 1/2"  
 Front and Back Side - As Shown

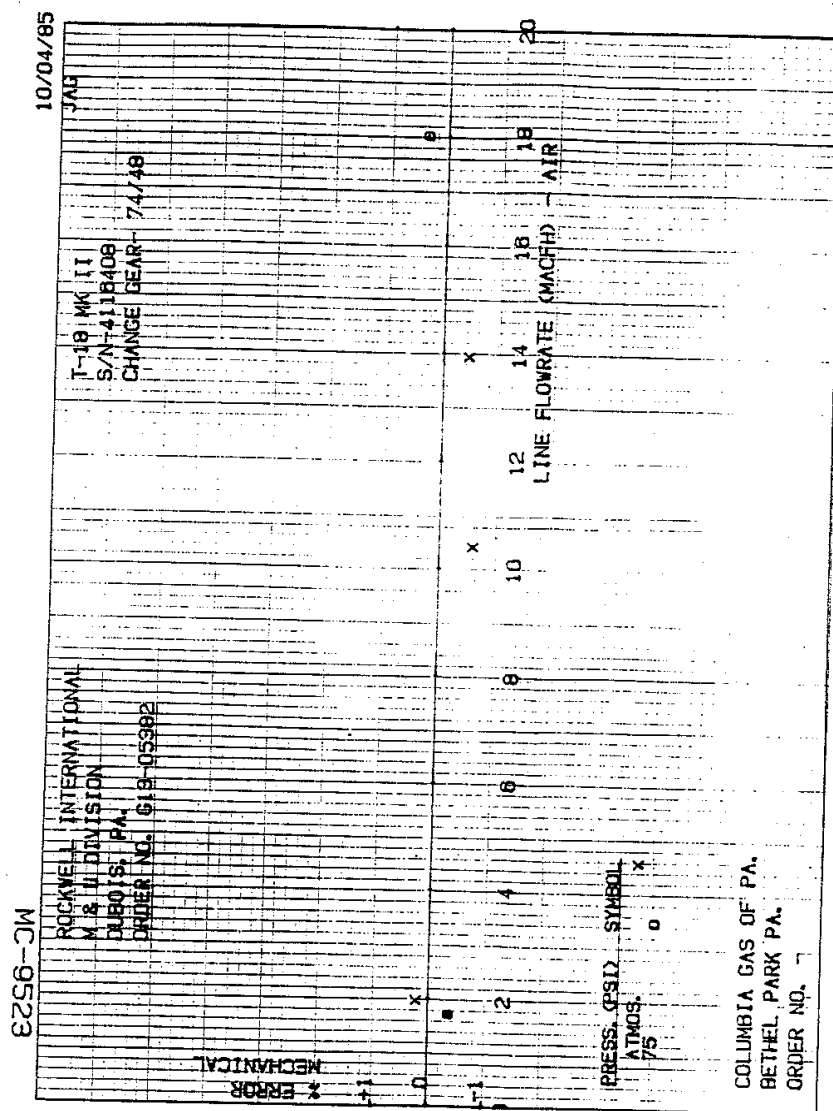


**Gas Standard**

Distribution Operations

|                               |   |  |
|-------------------------------|---|--|
| Effective Date:<br>05/30/1986 | <h2>Installation and Operation of<br/>Turbine Meters</h2> | Standard Number:<br><b>GS 6400.260(CG)</b><br>P&P 724-26 |
| Supersedes:<br>N/A            |   | Page 15 of 16  |

**EXHIBIT B**



Color - White  
Size - 8 1/2" x 11"



Gas Standard

Distribution Operations

|                               |  |  |
|-------------------------------|--|--|
| Effective Date:<br>05/30/1986 | <h2 style="margin: 0;">Installation and Operation of<br/>Turbine Meters</h2> | Standard Number:<br><b>GS 6400.260(CG)</b><br>P&P 724-26 |
| Supersedes:<br>N/A            |  | Page 16 of 16  |

EXHIBIT C

**COLUMBIA GAS**  
Distribution Companies

GAUGE SIZE & KIND \_\_\_\_\_  
GAUGE RANGE \_\_\_\_\_  
MODEL NUMBER \_\_\_\_\_

**DISPLACEMENT METER READING  
AND STATION RECORD**

ADDRESS \_\_\_\_\_  
CITY-STATE \_\_\_\_\_

WORK COMPLETED BY-INITIAL \_\_\_\_\_

| METER KIND AND SIZE _____     |         | METER KIND AND SIZE _____     |       | METER KIND AND SIZE _____     |       |
|-------------------------------|---------|-------------------------------|-------|-------------------------------|-------|
| METER SERIAL NUMBER _____     |         | METER SERIAL NUMBER _____     |       | METER SERIAL NUMBER _____     |       |
| METER W. P. _____             |         | METER W. P. _____             |       | METER W. P. _____             |       |
| VOLUME PER REV./SCALLOP _____ |         | VOLUME PER REV./SCALLOP _____ |       | VOLUME PER REV./SCALLOP _____ |       |
| CHART NUMBER _____            |         | CHART NUMBER _____            |       | CHART NUMBER _____            |       |
| METER SEQ. _____              |         | METER SEQ. _____              |       | METER SEQ. _____              |       |
| 19                            | READING | REQ.                          | PRESS | TEMP.                         | INSP. |
| JAN                           |         |                               |       |                               |       |
| FEB                           |         |                               |       |                               |       |
| MAR                           |         |                               |       |                               |       |
| APR                           |         |                               |       |                               |       |
| MAY                           |         |                               |       |                               |       |
| JUN                           |         |                               |       |                               |       |
| JULY                          |         |                               |       |                               |       |
| AUG                           |         |                               |       |                               |       |
| SEPT                          |         |                               |       |                               |       |
| OCT                           |         |                               |       |                               |       |
| NOV                           |         |                               |       |                               |       |
| DEC                           |         |                               |       |                               |       |

| METER KIND AND SIZE _____     |         | METER KIND AND SIZE _____     |       | METER KIND AND SIZE _____     |       |
|-------------------------------|---------|-------------------------------|-------|-------------------------------|-------|
| METER SERIAL NUMBER _____     |         | METER SERIAL NUMBER _____     |       | METER SERIAL NUMBER _____     |       |
| METER W. P. _____             |         | METER W. P. _____             |       | METER W. P. _____             |       |
| VOLUME PER REV./SCALLOP _____ |         | VOLUME PER REV./SCALLOP _____ |       | VOLUME PER REV./SCALLOP _____ |       |
| CHART NUMBER _____            |         | CHART NUMBER _____            |       | CHART NUMBER _____            |       |
| METER SEQ. _____              |         | METER SEQ. _____              |       | METER SEQ. _____              |       |
| 19                            | READING | REQ.                          | PRESS | TEMP.                         | INSP. |
| JAN                           |         |                               |       |                               |       |
| FEB                           |         |                               |       |                               |       |
| MAR                           |         |                               |       |                               |       |
| APR                           |         |                               |       |                               |       |
| MAY                           |         |                               |       |                               |       |
| JUN                           |         |                               |       |                               |       |
| JULY                          |         |                               |       |                               |       |
| AUG                           |         |                               |       |                               |       |
| SEPT                          |         |                               |       |                               |       |
| OCT                           |         |                               |       |                               |       |
| NOV                           |         |                               |       |                               |       |
| DEC                           |         |                               |       |                               |       |

| METER KIND AND SIZE _____     |         | METER KIND AND SIZE _____     |       | METER KIND AND SIZE _____     |       |
|-------------------------------|---------|-------------------------------|-------|-------------------------------|-------|
| METER SERIAL NUMBER _____     |         | METER SERIAL NUMBER _____     |       | METER SERIAL NUMBER _____     |       |
| METER W. P. _____             |         | METER W. P. _____             |       | METER W. P. _____             |       |
| VOLUME PER REV./SCALLOP _____ |         | VOLUME PER REV./SCALLOP _____ |       | VOLUME PER REV./SCALLOP _____ |       |
| CHART NUMBER _____            |         | CHART NUMBER _____            |       | CHART NUMBER _____            |       |
| METER SEQ. _____              |         | METER SEQ. _____              |       | METER SEQ. _____              |       |
| 19                            | READING | REQ.                          | PRESS | TEMP.                         | INSP. |
| JAN                           |         |                               |       |                               |       |
| FEB                           |         |                               |       |                               |       |
| MAR                           |         |                               |       |                               |       |
| APR                           |         |                               |       |                               |       |
| MAY                           |         |                               |       |                               |       |
| JUN                           |         |                               |       |                               |       |
| JULY                          |         |                               |       |                               |       |
| AUG                           |         |                               |       |                               |       |
| SEPT                          |         |                               |       |                               |       |
| OCT                           |         |                               |       |                               |       |
| NOV                           |         |                               |       |                               |       |
| DEC                           |         |                               |       |                               |       |

REMARKS:

LAST INTER. CAL. \_\_\_\_\_

LAST METER PROVER TEST \_\_\_\_\_

LAST OIL CHANGE \_\_\_\_\_

LAST SPIN TEST \_\_\_\_\_

LAST LEAKAGE TEST \_\_\_\_\_

LAST FILTER INSP. \_\_\_\_\_

LAST STRAINER INSP. \_\_\_\_\_

LAST STATIC TEST (SPITS) \_\_\_\_\_

LAST METER INSP. \_\_\_\_\_

CLASS STATION \_\_\_\_\_

ACCURACY TEST \_\_\_\_\_

RED NUMBERS INDICATE \_\_\_\_\_

INSP. DUE \_\_\_\_\_

COMPLETED \_\_\_\_\_

LAST METER INSP. \_\_\_\_\_

INSP. \_\_\_\_\_

TEMP. \_\_\_\_\_

PRESS \_\_\_\_\_

REQ. \_\_\_\_\_

READING \_\_\_\_\_

VANES \_\_\_\_\_

NAME OF CUSTOMER \_\_\_\_\_

STATION NUMBER \_\_\_\_\_

Color - White

Size - 8 1/2" x 11"

Front and Backside - Same

Three Hole Punched

FORM 6-79-050  
1-80



Distribution Operations

|                               |  |  |
|-------------------------------|--|--|
| Effective Date:<br>09/08/1986 | <b>Recording Backprint Information<br/>on Meter Charts</b> | Standard Number:<br><b>GS 6400.350(CG)</b><br>P&P 724-35 |
| Supersedes:<br>N/A            |  | Page 1 of 10   |

Companies Affected:

|                                     |   |   |
|-------------------------------------|---|---|
| <input type="checkbox"/> NIPSCO     | <input checked="" type="checkbox"/> CGV | <input checked="" type="checkbox"/> CMD |
| <input type="checkbox"/> NIFL       | <input checked="" type="checkbox"/> CKY | <input checked="" type="checkbox"/> COH |
| <input type="checkbox"/> Kokomo Gas | <input type="checkbox"/> CMA            | <input checked="" type="checkbox"/> CPA |

**REFERENCE**    None

**1. GENERAL**

The backprint information recorded by meter inspectors or chart changers at the time of chart change is the basic information required by the Finance Gas Measurement Section to process a chart in an accurate and efficient manner. It is essential that the backprint information be legible, accurate and complete. Any irregularities from normal operations should be explained in the Remarks section.

Medium soft lead pencils are recommended for recording chart information. Ink or ball point pens or red pencils shall not be used.

**2. PROCEDURE FOR RECORDING BACKPRINT INFORMATION ON METER CHARTS**

Backprint information that is not included under items a thru n, and blank spaces that are "double blocked" will be completed by the Finance-Gas Measurement Section.

The following instructions shall be used to complete the required backprint information:

- a. Company Symbol (all charts)  
The "Company Symbol(s)" identifies the selling and/or purchasing company and is shown in Exhibit A.
- b. Station Name (All charts)  
The point of delivery - usually the customer's name.
- c. Volume per Revolution - Meter Driven Gauge (Displacement and Turbine Meter Charts)  
Indicate the volume of gas that will pass through the meter for one revolution of the chart.
- d. Volume per Scallop - Clock Driven Gauge (Displacement and Turbine Meter Charts)

*This document is considered CONTROLLED only when viewed electronically on the Company's intranet. Printed or other electronic copies may not be current, and the intranet version should be used to verify.*



Distribution Operations

|                               |  |  |
|-------------------------------|--|--|
| Effective Date:<br>09/08/1986 | <b>Recording Backprint Information<br/>on Meter Charts</b> | Standard Number:<br><b>GS 6400.350(CG)</b><br>P&P 724-35 |
| Supersedes:<br>N/A            |  | Page 2 of 10   |

Indicate the volume of gas that will pass through the meter for one scallop recorded on the chart.

e. Orifice Plate (Orifice Meter Charts)

Indicate the orifice size and the internal diameter of the orifice meter run, respectively, e.g., 1 3/4" x 4".

f. Chart Placed By and Chart Removed by (All Charts).

The person placing the chart shall print their first initial and last name. The person removing the chart shall print their first initial and last name.

g. Gravitometer Number (Gravitometer Charts).

The identifying number of the gravitometer

h. Station ID Number (All Except Gravitometer Charts).

Indicate Area Identification number (6-New York, Pennsylvania and Maryland; 7-Ohio and 8-Kentucky and Virginia). Record Alpha Prefix, Station Number and Seq. (Meter Sequence Number). Refer to [GS 6400.200\(CG\)](#) "Measuring Station Numbering System - Gas Measurement Billing (GMB)," for detailed explanation.

i. Placed and Removed Month, Day and Hour (All Charts)

All blocks shall be completed. A zero "0" shall precede digits 1 through 9 for month, day, and hour e.g., 01 thru 09. An A.M. or P.M. designation is required.

j. Year (All Charts)

Enter the last two digits of the year chart removed.

k. SEQ. (Displacement and Turbine Meter Charts)

Beginning from left to right show the Meter Sequence Number (SEQ.) for each meter run in the station. Meter sequence Number 1 is a duplication of the SEQ. reported in the Station ID Number, but it is essential that it be shown. A capital V in the SEQ. block indicates a rotary meter veeder counter reading (refer to Exhibit G).

l. Removed Reading, Placed Reading and Difference (Displacement and Turbine Meter Charts)

m. Pressure Range and Temperature Range (Displacement and Turbine Meter Charts)

The maximum range of the pressure element and temperature element.



Distribution Operations

|                               |  |  |
|-------------------------------|--|--|
| Effective Date:<br>09/08/1986 | <b>Recording Backprint Information<br/>on Meter Charts</b> | Standard Number:<br><b>GS 6400.350(CG)</b><br>P&P 724-35 |
| Supersedes:<br>N/A            |  | Page 3 of 10   |

- n. Differential Pressure Range and Static Pressure Range (Orifice Meter Charts)

The maximum range of the differential pressure element and the pressure element.

**3. EXAMPLES OF COMPLETED BACKPRINTING FOR VARIOUS CHART TYPES**

Exhibit B Gravitometer Chart Backprinting

Exhibit C Temperature Chart Backprinting

Exhibit D Orifice Meter Chart Backprinting

Exhibit E Displacement and Turbine Meter Chart Backprinting, Single Meter

Exhibit F Displacement and Turbine Meter Chart Backprinting, Two Meters, Single Gauge

Exhibit G Displacement and Turbine Meter Chart Backprinting, Single Rotary Meter with a veeder Counter



**Gas Standard**

Distribution Operations

|                               |  |  |
|-------------------------------|--|--|
| Effective Date:<br>09/08/1986 | <b>Recording Backprint Information<br/>on Meter Charts</b> | Standard Number:<br><b>GS 6400.350(CG)</b><br>P&P 724-35 |
| Supersedes:<br>N/A            |  | Page 4 of 10   |

**EXHIBIT A**

| <u>COMPANY SYMBOL FOR USE IN STATION NAME</u> |               |
|---|---------------|
| <u>Company Name</u>                           | <u>Symbol</u> |
| Columbia Gas Transmission                     | T             |
| Columbia Gas of Kentucky                      | K             |
| Columbia Gas of Maryland                      | M             |
| Columbia Gas of Ohio                          | O             |
| Columbia Gas of Pennsylvania                  | P             |
| Columbia Gas of Virginia                      | V             |






Distribution Operations

|                               |  |  |
|-------------------------------|--|--|
| Effective Date:<br>09/08/1986 | <b>Recording Backprint Information<br/>on Meter Charts</b> | Standard Number:<br><b>GS 6400.350(CG)</b><br>P&P 724-35 |
| Supersedes:<br>N/A            |  | Page 5 of 10   |

EXHIBIT B



|                |              |
|----------------|--------------|
| COMPANY SYMBOL | STATION NAME |
| M              | KILGORE      |

|                             |
|-----------------------------|
| CHART PLACED BY: R. GOOD    |
| CHART REMOVED BY: D. BETTER |

| CHART TYPE | GRAVITOMETER NUMBER | PLACED |      |       | REMOVED |      |       | FRACTION CODE | BET CODE | SI CODE | PREPARED BY |
|------------|---------------------|--------|------|-------|---------|------|-------|---------------|----------|---------|-------------|
|            |                     | MONTH  | DATE | HOUR  | MONTH   | DATE | HOUR  |               |          |         |             |
| 44         | 371                 | 10     | 17   | 09 AM | 10      | 23   | 09 AM |               |          |         |             |
|            |                     |        |      |       |         |      |       |               |          |         | 81          |

|   | TRACE LENGTH | SPECIFIC GRAVITY VALUE |  |  |  |
|---|--------------|------------------------|--|--|--|
| 1 |              |                        |  |  |  |
| 2 |              |                        |  |  |  |
| 3 |              |                        |  |  |  |

|   | TRACE LENGTH | SPECIFIC GRAVITY VALUE |  |  |  |
|---|--------------|------------------------|--|--|--|
| 9 |              |                        |  |  |  |

REMARKS:

CLOCK STOPPED -

REPLACED 10-23-81 AT

9:00 A.M.

D. BETTER


Gravitometer Chart Backprinting  
Chart Diameters 10" and 12"



Distribution Operations

|                               |  |  |
|-------------------------------|--|--|
| Effective Date:<br>09/08/1986 | <b>Recording Backprint Information<br/>on Meter Charts</b> | Standard Number:<br><b>GS 6400.350(CG)</b><br>P&P 724-35 |
| Supersedes:<br>N/A            |  | Page 6 of 10   |

EXHIBIT C



|                                   |  |                     |  |
|-----------------------------------|--|---------------------|--|
| <b>COMPANY SYMBOL</b>             |  | <b>STATION NAME</b> |  |
| 0                                 |  | WILSON MFG. Co.     |  |
| <b>CHART PLACED BY:</b> B. SMITH  |  |                     |  |
| <b>CHART REMOVED BY:</b> J. JONES |  |                     |  |

| STATION ID NUMBER |         |              |                | PLACED |       |      | REMOVED |     |      | YEAR  |      |    |     |      |
|-------------------|---------|--------------|----------------|--------|-------|------|---------|-----|------|-------|------|----|-----|------|
| CHART TYPE        | AREA ID | ALPHA PREFIX | STATION NUMBER | SEC.   | MONTH | DATE | HR      | MIN | SEC. | MONTH | DATE | HR | MIN | SEC. |
| 53                | 7       | S            | 10765          | 0      | 02    | 10   | 01      |     |      | 03    | 01   | 09 |     |      |
|                   |         |              |                |        |       |      |         |     |      |       |      |    | AM  |      |
|                   |         |              |                |        |       |      |         |     |      |       |      |    | PM  |      |
|                   |         |              |                |        |       |      |         |     |      |       |      |    | 8   | 6    |

|   | TRACE LENGTH |   | TEMPERATURE VALUE |   |
|---|--------------|---|-------------------|---|
|   | 1            | 2 | 3                 | 4 |
| 1 |              |   |                   |   |
| 2 |              |   |                   |   |
| 3 |              |   |                   |   |

|                 |  |
|-----------------|--|
| <b>REMARKS:</b> |  |
|                 |  |
|                 |  |
|                 |  |
|                 |  |

|   | TRACE LENGTH |   | TEMPERATURE VALUE |   |
|---|--------------|---|-------------------|---|
|   | 1            | 2 | 3                 | 4 |
| 9 |              |   |                   |   |

Temperature Chart Backprinting  
 Chart Diameters 8" and 12"



**Gas Standard**

Distribution Operations

|                               |  |  |
|-------------------------------|--|--|
| Effective Date:<br>09/08/1986 | <b>Recording Backprint Information<br/>on Meter Charts</b> | Standard Number:<br><b>GS 6400.350(CG)</b><br>P&P 724-35 |
| Supersedes:<br>N/A            |  | Page 7 of 10   |

**EXHIBIT D**

|  |  |
|--|--|
| COMPANY SYMBOL<br><b>0</b>               | STATION NAME<br><b>WILSON MFG. CO.</b> |
| ORIFICE PLATE SIZE<br><b>2 1/4" x 6"</b> | CHART PLACED BY:<br><b>B. SMITH</b>    |
|  | CHART REMOVED BY:<br><b>V. JONES</b>   |

| CHART TYPE | STATION ID NUMBER |              |                   |          | PLACED    |           |           | REMOVED   |           |           | YEAR      |
|------------|-------------------|--------------|-------------------|----------|-----------|-----------|-----------|-----------|-----------|-----------|-----------|
|            | AREA ID           | ALPHA TAG#12 | STATION NUMBER 11 | SEC.     | MONTH     | DATE      | HOUR      | MONTH     | DATE      | HOUR      |           |
| <b>63</b>  | <b>7</b>          | <b>S</b>     | <b>10765</b>      | <b>1</b> | <b>02</b> | <b>10</b> | <b>01</b> | <b>03</b> | <b>01</b> | <b>09</b> | <b>AM</b> |
|            |                   |              |                   |          |           |           |           |           |           |           | <b>86</b> |

|          |  |
|----------|--|
| <b>1</b> | ORIFICE SIZE   |
| <b>2</b> | REGISTRATION      TRACE LENGTH OR AVG. IN.      PRESSURE VALUE |
| <b>3</b> |  |
| <b>4</b> |  |

|          |  |
|----------|--|
| <b>9</b> | ORIFICE SIZE   |
| <b>9</b> | REGISTRATION      TRACE LENGTH OR AVG. IN.      PRESSURE VALUE |
| <b>9</b> |  |
| <b>9</b> |  |

|  |
|--|
| DIFFERENTIAL PRESSURE RANGE      0 = <u>100</u> INCHES |
| STATIC PRESSURE RANGE              0 = <u>250</u> PSIG |
| REMARKS:   |
|  |
|  |
|  |

Orifice Meter Chart Backprinting  
Chart Diameters 8", 10" and 12"



Gas Standard

Distribution Operations

|                               |  |  |
|-------------------------------|--|--|
| Effective Date:<br>09/08/1986 | <b>Recording Backprint Information<br/>on Meter Charts</b> | Standard Number:<br><b>GS 6400.350(CG)</b><br>P&P 724-35 |
| Supersedes:<br>N/A            |  | Page 8 of 10   |

**EXHIBIT E**

SINGLE METER

|                                 |                                      |  |              |                                     |             |                                    |             |
|---------------------------------|--------------------------------------|--|--------------|-------------------------------------|-------------|------------------------------------|-------------|
| <b>COMPANY SYMBOL</b><br>T P    |                                      | <b>STATION NAME</b><br>ABC STEEL CORP. |              |                                     |             |                                    |             |
| <b>VOL PER REV.</b>             |                                      | <b>VOL PER SCAL</b>                    |              | <b>PLACED BY:</b> G. WORKER         |             |                                    |             |
| <b>MCF</b>                      |                                      | <b>100 MCF</b>                         |              | <b>REMOVED BY:</b> J. DOE           |             |                                    |             |
| <b>CHART TYPE</b><br>75         | <b>STATION ID NUMBER</b><br>6 Y 0744 |  |              | <b>PLACED DATE</b><br>1 0 1 2 6 0 9 |             | <b>REMOVED DATE</b><br>0 1 2 8 0 9 |             |
| <b>AREA</b>                     | <b>STATION</b>                       | <b>REG.</b>                            | <b>MONTH</b> | <b>DATE</b>                         | <b>HOUR</b> | <b>MONTH</b>                       | <b>DATE</b> |
|                                 |                                      |  |              |                                     |             |                                    |             |
| <b>REMOVED READING</b><br>79801 | <b>REMOVED READING</b>               |  |              | <b>REMOVED READING</b>              |             | <b>REMOVED READING</b><br>85       |             |
| <b>PLACED READING</b><br>79513  | <b>PLACED READING</b>                |  |              | <b>PLACED READING</b>               |             | <b>PLACED READING</b>              |             |
| <b>DIFFERENCE</b><br>288        | <b>DIFFERENCE</b>                    |  |              | <b>DIFFERENCE</b>                   |             | <b>DIFFERENCE</b>                  |             |

|                     |                     |                       |
|---------------------|---------------------|-----------------------|
| <b>DISPLACEMENT</b> | <b>SCALE LENGTH</b> | <b>PRESSURE VALUE</b> |
|                     | <b>SCALE LENGTH</b> | <b>PRESSURE VALUE</b> |
|                     | <b>SCALE LENGTH</b> | <b>PRESSURE VALUE</b> |
|                     | <b>SCALE LENGTH</b> | <b>PRESSURE VALUE</b> |

|                     |                 |                 |
|---------------------|-----------------|-----------------|
| <b>DISPLACEMENT</b> | <b>P. VALUE</b> | <b>T. VALUE</b> |
| 9                   |                 |                 |

|   |
|---|
| <b>PRESSURE RANGE</b> 0- 500 PSIG   |
| <b>TEMPERATURE RANGE</b> 0- 250 °F  |
| <b>REMARKS:</b><br>CHART MISPLACED<br>AT 8:00 A.M. - SHOULD<br>HAVE BEEN PLACED<br>AT 9:00 A.M.<br>J. DOE |

ARC 813

Displacement and Turbine Meter Chart Backprinting  
Chart Diameters 8", 10" and 12"




Gas Standard

Distribution Operations

|                               |  |  |
|-------------------------------|--|--|
| Effective Date:<br>09/08/1986 | <b>Recording Backprint Information<br/>on Meter Charts</b> | Standard Number:<br><b>GS 6400.350(CG)</b><br>P&P 724-35 |
| Supersedes:<br>N/A            |  | Page 9 of 10   |

EXHIBIT F

TWO METERS - SINGLE GAUGE



|                       |  |                          |  |                   |  |               |  |       |  |                |  |  |  |
|-----------------------|--|--------------------------|--|-------------------|--|---------------|--|-------|--|----------------|--|--|--|
| <b>COMPANY SYMBOL</b> |  | <b>STATION NAME</b>      |  |                   |  |               |  |       |  |                |  |  |  |
| T-P                   |  | ABC STEEL CORP.          |  |                   |  |               |  |       |  |                |  |  |  |
| <b>VOL PER REV.</b>   |  | <b>VOL PER SCAL.</b>     |  | <b>PLACED BY:</b> |  |               |  |       |  |                |  |  |  |
| MCF 100               |  | MCF                      |  | G. WORKER         |  |               |  |       |  |                |  |  |  |
| <b>CHART TYPE</b>     |  | <b>STATION ID NUMBER</b> |  |                   |  | <b>PLACED</b> |  |       |  | <b>REMOVED</b> |  |  |  |
| 75                    |  | 6Y 0748                  |  | 1 01 26           |  | 09 AM         |  | 01 28 |  | 09 AM          |  |  |  |
| 11                    |  | 79801                    |  | 79811             |  | 79513         |  | 79525 |  | 8.5            |  |  |  |
| 288                   |  | 286                      |  |                   |  |               |  |       |  |                |  |  |  |

|                    |              |                    |
|--------------------|--------------|--------------------|
| COMPOSITE QUANTITY | TRACE LENGTH | DISPLACEMENT VALUE |
|                    | TRACE LENGTH | TEMP. VALUE        |
|                    | TRACE LENGTH | DISPLACEMENT VALUE |
|                    | TRACE LENGTH | TEMP. VALUE        |

|                                    |  |
|------------------------------------|--|
| <b>PRESSURE RANGE 0- 500 PSIG</b>  |  |
| <b>TEMPERATURE RANGE 0- 250 °F</b> |  |
| <b>REMARKS:</b>                    |  |
|                                    |  |
|                                    |  |
|                                    |  |

|   |                   |  |                 |  |                 |  |
|---|-------------------|--|-----------------|--|-----------------|--|
| 9 | <b>DIFFERENCE</b> |  | <b>P, VALUE</b> |  | <b>T, VALUE</b> |  |
|   |                   |  |                 |  |                 |  |

Displacement and Turbine Meter Chart Backprinting  
Chart Diameters 8", 10" and 12"



Gas Standard

Distribution Operations

|                               |  |  |
|-------------------------------|--|--|
| Effective Date:<br>09/08/1986 | <b>Recording Backprint Information<br/>on Meter Charts</b> | Standard Number:<br><b>GS 6400.350(CG)</b><br>P&P 724-35 |
| Supersedes:<br>N/A            |  | Page 10 of 10  |

**EXHIBIT G**

SINGLE ROTARY METER WITH VEEDER COUNTER

|                                      |  |  |  |
|--------------------------------------|--|--|--|
| <b>COMPANY SYMBOL</b><br>F P         |  | <b>STATION NAME</b><br>ABC STEEL CORP. |  |
| <b>VOL. PER REV.</b><br>1000 MCF     |  | <b>PLACED BY:</b><br>G. WORKER         |  |
| <b>CHART TYPE</b><br>75              |  | <b>MCF REMOVED BY:</b><br>J. DOE       |  |
| <b>STATION ID NUMBER</b><br>6 Y 0744 |  | <b>PLACED</b>                          |  |
| <b>AREA</b><br>DEC.                  |  | <b>REMOVED</b>                         |  |
| MONTH                                |  | MONTH                                  |  |
| DATE                                 |  | DATE                                   |  |
| HOUR                                 |  | HOUR                                   |  |
| AM                                   |  | AM                                     |  |
| PM                                   |  | PM                                     |  |
| YEAR                                 |  | YEAR                                   |  |
| REMOVED READING<br>79801             |  | REMOVED READING<br>79811               |  |
| PLACED READING<br>79513              |  | PLACED READING<br>79523                |  |
| DIFFERENCE<br>288                    |  | DIFFERENCE<br>288                      |  |

|                            |             |                  |
|----------------------------|-------------|------------------|
| <b>COMMODITY CARRYOVER</b> | MADE LENGTH | DISPOSABLE VALUE |
|                            | MADE LENGTH | DISPOSABLE VALUE |
|                            | MADE LENGTH | DISPOSABLE VALUE |
|                            | MADE LENGTH | DISPOSABLE VALUE |

|                                    |
|------------------------------------|
| <b>PRESSURE RANGE 0- 500 PSIG</b>  |
| <b>TEMPERATURE RANGE 0- 250 °F</b> |
| <b>REMARKS:</b>                    |
|                                    |
|                                    |
|                                    |

|                   |                 |                 |
|-------------------|-----------------|-----------------|
| <b>DIFFERENCE</b> | <b>P, VALUE</b> | <b>T, VALUE</b> |
| 9                 |                 |                 |

Displacement and Turbine Meter Chart Backprinting  
Chart Diameters 8", 10" and 12"



Distribution Operations

|                               |   |  |
|-------------------------------|---|--|
| Effective Date:<br>03/10/1981 | <b>Chart Changing and Meter Reading<br/>- MGA</b> | Standard Number:<br><b>GS 6400.410(CG)</b><br>P&P 724-41 |
| Supersedes:<br>N/A            |   | Page 1 of 9  |

Companies Affected:

|                                     |   |   |
|-------------------------------------|---|---|
| <input type="checkbox"/> NIPSCO     | <input checked="" type="checkbox"/> CGV | <input checked="" type="checkbox"/> CMD |
| <input type="checkbox"/> NIFL       | <input checked="" type="checkbox"/> CKY | <input checked="" type="checkbox"/> COH |
| <input type="checkbox"/> Kokomo Gas | <input type="checkbox"/> CMA            | <input checked="" type="checkbox"/> CPA |

**REFERENCE**    None

**1. GENERAL REQUIREMENTS**

All charts from meter driven gauges and orifice gauges may be subject to scanning by an electronic chart scanner; therefore, extreme care should be exercised in the blotting and handling of these charts to insure a clean, neat and intense recording.

Diaphragm, rotary and turbine meter accounts that are processed by the Finance-Gas Measurement Section are billed in Mcf (one thousand cubic feet), therefore, the reading of the meter indexes shall be limited to reading the circular dials or digits to and including the 10,000 cubic foot hand or digit.

Equipment malfunctions, unusual conditions and the corrective action taken shall be noted in the Remarks section of the chart back-printing or meter reading record (see Exhibit A).

**2. DIAPHRAGM, ROTARY AND TURBINE METER CHART CHANGING OR METER READING**

**2.1 Chart Record Verification**

The meter index registration shall be recorded on the chart backprinting (removed index reading minus the placed index reading) and compared to the recorded volumetric registration on the face of the chart to verify the delivered volumes.

**2.2 Chart Placement**

The chart on a clock driven gauge shall be placed so that the volume pen is at the correct time on the chart. The chart on a meter driven gauge shall be placed so that the volume pen is at the correct zero arc.

**2.3 Meter Index Readings**

All meters billed through the Finance-Gas Measurement Section that are not equipped

*This document is considered CONTROLLED only when viewed electronically on the Company's intranet. Printed or other electronic copies may not be current, and the intranet version should be used to verify.*



Distribution Operations

|                               |  |  |
|-------------------------------|--|--|
| Effective Date:<br>03/10/1981 | <b>Chart Changing and Meter Reading<br/>                 - MGA</b> | Standard Number:<br><b>GS 6400.410(CG)</b><br>P&P 724-41 |
| Supersedes:<br>N/A            |  | Page 2 of 9  |

with recording gauges shall have their index readings reported on Form CS 6-175, "Displacement Meter Reading Records," or Form CS 6-199, "Meter Reading Card." (Meters equipped with a standard index, less gauge that are in manifold with a meter equipped with a recording gauge are excluded. In these cases, the readings of the meter(s) equipped with a standard index are recorded on the chart of the manifold meter.)

**2.4 Non-Registering Meters**

When a meter has not registered flow since the last chart change or meter reading, the reason, if definitely known, should be noted in the Remarks section of the chart backprinting or meter reading record, e.g., meter passing gas but not registering, customer using alternate fuel, plant shut down due to employees being on vacation or strike, etc.

**3. ORIFICE METER CHART CHANGING**

**3.1 Chart Placement**

When changing charts, the differential pressure pen is to be set on the chart as close as possible to the correct time of day.

**3.2 Measurement Personnel**

Where charts are changed on regularly scheduled dates by measurement personnel, the following will apply:

- a. The zero test of the differential pressure element under pressure will be required on 31-day charts only. Charts other than 31-day charts may also be zeroed if there appears to be a malfunction of the gauge. If an adjustment of the differential pressure pen is required, the amount of adjustment shall be so noted in the Remarks section of the chart backprinting.
- b. The time on the chart, as indicated by the differential pressure pen, is referred to as the "Chart Time." The "Chart Time" versus the correct time for the period of the chart drive, e.g., 24-hour, 7-day, etc., may vary by the maximum time variations given below without requiring adjustment of the chart drive (clock):





Distribution Operations

|                               |   |  |
|-------------------------------|---|--|
| Effective Date:<br>03/10/1981 | <b>Chart Changing and Meter Reading<br/>- MGA</b> | Standard Number:<br><b>GS 6400.410(CG)</b><br>P&P 724-41 |
| Supersedes:<br>N/A            |   | Page 3 of 9  |

| <u>Type of Chart Drive</u>                         | <u>Maximum Variation</u> |
|--|--------------------------|
| 24-Hour  | ± 10 Minutes             |
| 24-Hour Automatic Chart Changer<br>(Weekly Change) | ± 1 Hour                 |
| 72-Hour  | ± 1/2 Hour               |
| 7-Day  | ± 1 Hour                 |
| 8-Day  | ± 1 Hour                 |
| 31-Day   | ± 4 Hours                |

When an adjustment is required, the amount of time fast or slow and the corrective action taken shall be noted in the Remarks section of the chart backprinting, e.g., Clock 5 hours slow - adjusted same.

- c. The differential pen arc and the static pressure pen lag should be observed on the removed chart and adjusted, if required. A correctly arcing differential pressure pen will trace the arc on the chart. The correct static pressure pen lag is equivalent to 15 minutes on a 24-hour chart at zero pressure.

**3.3 Other Personnel**

Where charts are changed by other than measurement personnel, the following will apply:

- a. A zero test of the differential pressure element under pressure will be required on 31-day charts only. Charts other than 31-day charts may also be zeroed if the chart changer feels it necessary.
- b. The supervisor should be advised when:
  1. the zero test indicates a high or low zero,
  2. the "Chart Time" versus the correct time is not within the limits specified in 3.2 b,
  3. there is some other malfunction of the gauge.

Problems shall be noted in the Remarks section of the chart backprinting, e.g., Clock 5 hours fast - notified supervisor (name), etc.

**4. INK COLOR CODES**

The following ink color codes shall be adhered to without exception:



Distribution Operations

|                               |   |  |
|-------------------------------|---|--|
| Effective Date:<br>03/10/1981 | <b>Chart Changing and Meter Reading<br/>- MGA</b> | Standard Number:<br><b>GS 6400.410(CG)</b><br>P&P 724-41 |
| Supersedes:<br>N/A            |   | Page 4 of 9  |

- a. Meter Driven Gauge Pressure Recording. . . . . BLACK
- b. Meter Driven Gauge Temperature Recording . . . . . RED
- c. Meter Driven Gauge - Time Blip Recording . . . . . RED or BLACK
- d. Clock Driven Gauge Pressure Recording. . . . . BLACK
- e. Clock Driven Gauge Temperature Recording . . . . . RED
- f. Clock Driven Volume Saclop Recording. . . . . RED or BLACK
- g. Temperature Gauge Recording. . . . . RED
- h. Orifice Meter Static Pressure Recording. . . . . BLACK
- i. Orifice Meter Differential Pressure Recording. . . . . RED
- j. Specific Gravity Recording . . . . . RED
- k. Calorimeter Recording. . . . . RED



**Gas Standard**

Distribution Operations

|                               |   |  |
|-------------------------------|---|--|
| Effective Date:<br>03/10/1981 | <h1>Chart Changing and Meter Reading<br/>- MGA</h1> | Standard Number:<br><b>GS 6400.410(CG)</b><br>P&P 724-41 |
| Supersedes:<br>N/A            |   | Page 5 of 9  |

**EXHIBIT A  
(1 of 5)**

The form is a 'Typical Displacement Meter Chart Backprinting Showing Remarks Section'. It contains the following sections:

- STATION NAME:** A large rectangular field for the station name.
- STATION NUMBER:** A field for the station number.
- CHART TYPE:** A field with the number '7' written in it.
- PLACED BY:** A field for the person who placed the chart.
- REMOVED BY:** A field for the person who removed the chart.
- PLACED DATE:** A field for the date the chart was placed.
- REMOVED DATE:** A field for the date the chart was removed.
- REMARKS:** A large grid area for recording meter readings and remarks. It has columns for 'DIFFERENCE', 'P. VALUE', and 'T. VALUE'. The number '9' is written in the first row of the 'DIFFERENCE' column.
- REMARKS (continued):** A section with horizontal lines for additional remarks.

TYPICAL DISPLACEMENT METER CHART  
 BACKPRINTING SHOWING REMARKS SECTION



**Gas Standard**

Distribution Operations

|                               |   |  |
|-------------------------------|---|--|
| Effective Date:<br>03/10/1981 | <h2>Chart Changing and Meter Reading<br/>- MGA</h2> | Standard Number:<br><b>GS 6400.410(CG)</b><br>P&P 724-41 |
| Supersedes:<br>N/A            |   | Page 6 of 9  |

**EXHIBIT A  
(2 of 5)**

STATION NAME

ORIFICE PLATE: \_\_\_\_\_ CHART PLACED BY: \_\_\_\_\_  
 SIZE: " X " CHART REMOVED BY: \_\_\_\_\_

CHART TYPE: **63** STATION ID NUMBER: \_\_\_\_\_  
 AREA ID: \_\_\_\_\_ PRESS: \_\_\_\_\_ SER: \_\_\_\_\_  
 MONTH: \_\_\_\_\_ DATE: \_\_\_\_\_ HOUR: \_\_\_\_\_ MONTH: \_\_\_\_\_ DATE: \_\_\_\_\_ HOUR: \_\_\_\_\_  
 YEAR: \_\_\_\_\_

ORIFICE SIZE: \_\_\_\_\_

| 1 | REGISTRATION | TRACE LENGTH OR AVERAGE IN. | PRESSURE VALUE |
|---|--------------|-----------------------------|----------------|
| 2 |              |                             |                |
| 3 |              |                             |                |
| 4 |              |                             |                |

REMARKS:

|  |
|--|
|  |
|  |
|  |
|  |
|  |
|  |

ORIFICE SIZE: \_\_\_\_\_

| 9 | REGISTRATION | TRACE LENGTH OR AVERAGE IN. | PRESSURE VALUE |
|---|--------------|-----------------------------|----------------|
|   |              |                             |                |
|   |              |                             |                |
|   |              |                             |                |

TYPICAL ORIFICE METER CHART BACKPRINTING  
SHOWING REMARKS SECTION





**Gas Standard**

Distribution Operations

|                                       |  |   |
|---------------------------------------|--|---|
| <p>Effective Date:<br/>03/10/1981</p> | <p><b>Chart Changing and Meter Reading<br/>- MGA</b></p> | <p>Standard Number:<br/><b>GS 6400.410(CG)</b><br/>P&amp;P 724-41</p> |
| <p>Supersedes:<br/>N/A</p>            |  | <p>Page 8 of 9</p>  |

**EXHIBIT A  
(4 of 5)**

|                  |       |               |                |                |             |               |            |
|------------------|-------|---------------|----------------|----------------|-------------|---------------|------------|
| STATION NAME     |       | METER READ BY |                | PREVIOUS       |             | PRESENT       |            |
| CHART TYPE       | AREA  | ALPHA         | STATION NUMBER | 1              | SEC.        | PREVIOUS      | PRESENT    |
| 10000            | 10000 | 10000         | 10000          | MONTH          | DAY         | YEAR          | MONTH      |
| PERCENT ACCURACY | SEC.  | IN MCF        | ALL READINGS   | PRESSURE COMP. | TEMP. COMP. | PRESSURE ADJ. | TEMP. ADJ. |
| 10000            | 10000 | 10000         | 10000          | 50             | 60          | 100           | 100        |

|                       |            |                          |            |              |            |
|-----------------------|------------|--------------------------|------------|--------------|------------|
| CONTRACT BASE (FRONT) |            | AT METERING PRESS./TEMP. |            | VEEDER INDEX |            |
| MILLIONS              | THOUSANDS  | MILLIONS                 | THOUSANDS  | MILLIONS     | THOUSANDS  |
| PRESENT               | PREVIOUS   | PRESENT                  | PREVIOUS   | PRESENT      | PREVIOUS   |
| DIFFERENCE            | DIFFERENCE | DIFFERENCE               | DIFFERENCE | DIFFERENCE   | DIFFERENCE |

|                                   |                  |
|-----------------------------------|------------------|
| DISPLACEMENT METER READING RECORD |                  |
| STANDARD INDEX                    | AIR CONDITIONING |
| 4                                 | 6                |
| LOW PRESSURE                      | 6                |

FORM GS 4.11'S CSD COLUMBIA GAS SYSTEM 12/78)

Front Side  
 COLOR - YELLOW  
 SIZE - 5-1/2" x 8" (As Shown)



**Gas Standard**

Distribution Operations

|                               |   |  |
|-------------------------------|---|--|
| Effective Date:<br>03/10/1981 | <h2>Chart Changing and Meter Reading<br/>- MGA</h2> | Standard Number:<br><b>GS 6400.410(CG)</b><br>P&P 724-41 |
| Supersedes:<br>N/A            |   | Page 9 of 9  |

**EXHIBIT A**  
**(5 of 5)**

**FOR USE IN DEVELOPING ESTIMATES BROUGHT ABOUT BY TESTS, BYPASSING, INSTRUMENT FAILURE, ETC.**

REAR       INDEX REGISTRATION  
 VEEDER

FOR ESTIMATE # AVG. PRESS. \_\_\_\_\_ PRESSURE MULTIPLIER FACTOR \_\_\_\_\_  
 (PRESSURE BASE \_\_\_\_\_ PSIA)  
 FOR ESTIMATE °F. AVG. TEMP. \_\_\_\_\_ TEMPERATURE MULTIPLIER FACTOR \_\_\_\_\_  
 SUPERCOMPRESSIBILITY FACTOR \_\_\_\_\_

TOTAL ESTIMATE \_\_\_\_\_ MCF

| NO. 1 DETAIL PERIOD |         | NO. 2 DETAIL PERIOD |         | TO   |     |
|---------------------|---------|---------------------|---------|------|-----|
| EST                 | PERCENT | EST                 | PERCENT | DEAD | MCF |
| BYP                 |         | BYP                 |         | PAST |     |
| FAST                |         | FAST                |         | TEST |     |
| SLOW                |         | SLOW                |         |      |     |
| TEST                |         | TEST                |         |      |     |
| ADJ                 |         | ADJ                 |         |      |     |

REMARKS \_\_\_\_\_

APPROVED \_\_\_\_\_ SIGNED \_\_\_\_\_ DIVISION MEASUREMENT SUPERVISOR  
 APPROVED \_\_\_\_\_ SIGNED \_\_\_\_\_ INDUSTRIAL SALES REPRESENTATIVE  
 APPROVED \_\_\_\_\_ SIGNED \_\_\_\_\_ CUSTOMER REPRESENTATIVE

Back Side  
COLOR - YELLOW  
SIZE - 5-1/2" x 8" (As Shown)



**Distribution Operations**

**Gas Standard**

|                               |  |  |
|-------------------------------|--|--|
| Effective Date:<br>05/01/2014 | <b>High Pressure Service Regulator<br/>and Meter Setting Selection</b> | Standard Number:<br><b>GS 6400.420</b> |
| Supersedes:<br>N/A            |  | Page 1 of 5                            |

Companies Affected:

|                                 |   |   |
|---------------------------------|---|---|
| <input type="checkbox"/> NIPSCO | <input checked="" type="checkbox"/> CGV | <input checked="" type="checkbox"/> CMD |
|                                 | <input checked="" type="checkbox"/> CKY | <input checked="" type="checkbox"/> COH |
|                                 | <input type="checkbox"/> CMA            | <input checked="" type="checkbox"/> CPA |

**REFERENCE** Columbia Gas System - Manual of Approved Procedures for Operations - Subpart H  
Columbia Gas System - Material Standardization Index No. 3 and No. 4

**1. GENERAL**

The purpose of this standard is to provide information for the selection of high pressure service regulator(s) for domestic meter installations.

A high pressure meter set assembly shall be used to supply gas to retail customers served from high pressure pipelines.

The regulator(s) shall be located outside the building being served. The regulator(s) upstream of the final cut service regulator shall be equipped with a pressure test plug when no other means of checking set pressure is available. The test plug will permit checking pressure by means of a matching test probe without shutting off the gas.

Relief devices shall be located at a place where the gas from the vent can escape freely into the atmosphere and away from any opening into the building.

Columbia Gas Distribution Companies' Drawing Number S-1300 (Exhibit A) illustrates the recommended regulators and installation practices from Transmission Company lines. For Distribution Company high pressure mains, the service lines shall be installed in accordance with GS 3020.010 "Service Line Installation." The selection of service regulators, in either case shall be in conformance with Sections 2, 3 and 4 of this procedure.

**2. SELECTION REQUIREMENTS**

Piping, valves, fittings and service regulator bodies shall be selected to conform to the maximum allowable operating pressure (MAOP) of the pipeline system or maximum operating pressure to which these components will be subjected to in case of regulator failure.

**3. FINAL-CUT SERVICE REGULATOR SELECTION**

The selection of the proper final-cut regulator depends on the maximum system pressure (MAOP) for the pressure rating and relief capacity, and on minimum operating pressure for

*This document is considered CONTROLLED only when viewed electronically on the Company's intranet. Printed or other electronic copies may not be current, and the intranet version should be used to verify.*





|                               |  |  |
|-------------------------------|--|--|
| Effective Date:<br>05/01/2014 | <b>High Pressure Service Regulator<br/>and Meter Setting Selection</b> | Standard Number:<br><b>GS 6400.420</b> |
| Supersedes:<br>N/A            |  | Page 2 of 5                            |

flow capacity. Based on this information, the following specifications have been determined for systems: 1) not exceeding 60 psig, and 2) over 60 psig and not exceeding 125 psig.

### **3.1 Maximum 60 psig**

A spring-loaded, domestic, service regulator with a 3/16 inch orifice meeting the specifications as stated in the Material Standards Index No. 3 or 4 and the approved regulators listed in Material Standard REG-0010(CG) "Regulators – Domestic Service Regulators 7" Delivery" or REG-0015(CG) "Regulator – Domestic Service Regulators 2 PSIG Delivery," as appropriate, shall be used to maintain normal utilization pressure to the customer. The maximum allowable operating pressure at the inlet of this service regulator shall be 60 psig to adequately limit the downstream pressure upon full relief.

### **3.2 Maximum 125 psig**

A spring-loaded, domestic, service regulator with a 1/8 inch orifice meeting the specifications as stated in the Material Standards Index No. 3 or 4 and the approved regulators listed in Material Standard REG-0010(CG) "Regulators – Domestic Service Regulators 7" Delivery" or REG-0015(CG) "Regulator – Domestic Service Regulators 2 PSIG Delivery," as appropriate, shall be used to maintain normal utilization pressure to the customer. The maximum allowable operating pressure at the inlet of this service regulator shall be 125 psig. Refer to GS 6500.105 "Service Regulator Requirements - Residential and Small Commercial" for set pressure, lock up, and other installation and maintenance requirements.

If the minimum operating pressure to this regulator will be below 10 psig, a high-pressure service regulator, according to Section 4.1, and a final-cut regulator with a 3/16 inch orifice, according to Section 3.1, shall be installed.

NOTE: If uprating a pipeline to a Maximum Allowable Operating Pressure greater than 60 psig, a thorough investigation of the service regulators must be conducted to determine if existing regulators need to be replaced. Several domestic regulator models have maximum inlet pressures of less than 125 psig.

## **4. HIGH PRESSURE SERVICE REGULATOR SELECTION**

### **4.1 Over 125 psig but not exceeding 200 psig**

When the maximum operating pressure is over 125 psig, but does not exceed 200 psig, one high-pressure service regulator in addition to the final-cut service regulator shall be required.

A spring loaded high-pressure service regulator with a 1/8 inch or smaller orifice,



|                               |  |  |
|-------------------------------|--|--|
| Effective Date:<br>05/01/2014 | <b>High Pressure Service Regulator<br/>and Meter Setting Selection</b> | Standard Number:<br><b>GS 6400.420</b> |
| Supersedes:<br>N/A            |  | Page 3 of 5                            |

internal relief, and synthetic valve disc, and set to deliver a pressure capable to meet load and relief requirements (normally 15 psig) shall be used for this pressure cut. The regulator selected to perform this pressure cut shall be rated by the manufacturer as being suitable to withstand the maximum allowable operating pressure of the pipeline system and shall have adequate relief capability to limit the pressure at the inlet of the final-cut service regulator to 60 psig or the manufacturer's recommended safe working pressure, whichever is less.

**4.2 Over 200 psig but not exceeding 1000 psig**

When the maximum operating pressure is over 200 psig, but does not exceed 1000 psig, two high-pressure service regulators providing two pressure cuts in addition to the final cut service regulator shall be required. The first-cut regulator shall be a spring-loaded high-pressure service regulator with a 1/8 inch or smaller orifice, internal relief, and synthetic valve disc, and set to deliver 100 psig. The second-cut regulator shall be a spring-loaded high pressure service regulator with a 1/8 inch or smaller orifice, internal relief, and synthetic valve disc, and set to deliver a pressure capable to meet load and relief requirements (normally 15 psig).

The first and second cut regulators shall be rated by the manufacturer as being suitable to withstand the maximum allowable operating pressure to which the regulator may be subjected and shall have adequate relief capability to limit the pressure at the inlet of the final cut service regulator to 60 psig or the manufacturer's recommended safe working pressure, whichever is less.

**4.3 Over 1000 psig but not exceeding 1440 psig**

When the maximum operating pressure is over 1000 psig, but does not exceed 1440 psig, two high-pressure service regulators providing two pressure cuts in addition to the final-cut service regulator shall be required. The first cut regulator shall be a spring loaded high pressure service regulator with a 1/8 inch or smaller orifice and synthetic valve disc. If this first cut regulator is used with a separate relief valve, the regulator shall be set to deliver 80 psig or whatever set pressure is required to limit the pressure buildup to 110 psig in the event of a regulator failure and operation of the relief valve. If the first cut regulator incorporates internal relief, it shall be set to deliver 100 psig. The type of first cut regulator to be used shall be governed by the Columbia Gas Distribution Companies' Standard Drawing S-130-A (Exhibit A).

The second cut regulator shall be a spring loaded high pressure service regulator with a 1/8 inch or smaller orifice, internal relief, synthetic valve disc, and set to deliver a pressure capable to meet load and relief requirements (normally 15 psig).

The first and second cut regulators shall be rated by the manufacturer as being suitable to withstand the maximum allowable operating pressure to which the regulator



***Distribution Operations***

**Gas Standard**

|                               |  |  |
|-------------------------------|--|--|
| Effective Date:<br>05/01/2014 | <b>High Pressure Service Regulator<br/>and Meter Setting Selection</b> | Standard Number:<br><b>GS 6400.420</b> |
| Supersedes:<br>N/A            |  | Page 4 of 5                            |

may be subjected and shall have adequate relief capability to limit the pressure at the inlet of the final cut service regulator to 60 psig or the manufacturer's recommended safe working pressure, whichever is less.

|                               |  |  |
|-------------------------------|--|--|
| Effective Date:<br>05/01/2014 | <b>High Pressure Service Regulator<br/>and Meter Setting Selection</b> | Standard Number:<br><b>GS 6400.420</b> |
| Supersedes:<br>N/A            |  | Page 5 of 5                            |

**EXHIBIT A**

| ITEM STOCK NO. | NO. QUAN. | SIZE      | DESCRIPTION   |
|----------------|-----------|-----------|---|
| 44-78-003      | 1         | 3/4" x 1" | SINKS ILL. CONVENTIONAL 3/4" BODY, WELD BASE, 1" MAIN AND GULLET, WITH 3/8" COPPER REINFORCING PUNCT. METAL, WELLS 1500-03-08H 500# WORK P.P. |
| 44-78-006      | 1         | 1" x 1"   | SPRINGS, TEE, WHEELER 90-80 WITH INNER WINGS, MODEL 10-1700A, WELD END BASE X WELD END GULLET, STEEL CAP, C. BRG. SILEV SEAL 140# W.P.        |
| 44-78-008      | 1         | 1" x 1"   | SPRINGS, TEE, CONVENTIONAL, 1" BODY, WELD 1" BASE WELD END GULLET, WITH 3/4" PUNCH WING, MODEL #111-03-09H, 500# WORK P.P.                    |
| 44-84-001      | 1         | 1"        | WALL, ALUMINUM CARBON STEEL, WALL #10-0628-03-03R, 10,000# W.P., ...DOWNSIDE PRESSURE REGULATOR   |
| 44-84-002      | 1         | 1"        | WALL, ALUMINUM CARBON STEEL, WALL #10-0628-03-03R, 10,000# W.P., ...DOWNSIDE PRESSURE REGULATOR   |
| 44-84-003      | 1         | 1"        | METER SETTING, DOMESTIC, 20"-1000 PSI, METRIC PRESSURE, REFER TO DWG. 5"-130 (DROCK ITEM)   |
| 44-84-004      | 1         | 1"        | METER SETTING, DOMESTIC, 20"-1400 PSI, METRIC PRESSURE, REFER TO DWG. 5"-130 (DROCK ITEM)   |

**NOTES:**

1. ANY NECESSARY GAS CLEANING EQUIPMENT OR HEADERS WILL BE PROVIDED BY OTHERS. LOCATION WILL BE DETERMINED AT THE OF INSTALLATION.
2. A SERVICE REGULATOR WITH LOW PRESSURE ADJUST MAY BE REQUIRED BY FIELD PERSONNEL BECAUSE OF A POSSIBLE SUPPLY QUALITY.
3. PRE-ASSEMBLED METER SET ASSEMBLY SHOULD BE USED WHENEVER POSSIBLE.
4. FOR SUPPLY LINES WITH MAP OVER 1400 PSI, REFER TO DRAWING 5"-130 (DROCK ITEM).

**TYPICAL METER SET ASSEMBLIES FOR MULTIPLE CUSTOMERS**

|  |   |
|--|---|
| MAX. DESIGN PRESSURE: _____ PSI<br>ACTUAL DESIGN PRESSURE: _____ PSI<br>(SEE DRAWINGS) | Engineering Consulting Services<br>Shared Services Center<br>(Indicate the Company or Consultant) |
| TEST PRESSURE: AT LEAST THE GREATER OF 1-1/2 TIMES ACTUAL DESIGN PRESSURE, OR 90 PSI   | Date: _____<br>Hours: _____<br>Project: _____<br>Title: _____                                     |
| Scale: 1"=1'-0"<br>X-BY: 0 X   | Date: _____<br>Drawn: _____<br>Checked: _____<br>Appr'd: _____<br>Title: <b>S-1300</b>            |



**Gas Standard**

Distribution Operations

|                               |                                  |  |
|-------------------------------|----------------------------------|--|
| Effective Date:<br>11/15/1984 | <b>Buried Service Regulators</b> | Standard Number:<br><b>GS 6400.440(CG)</b><br>P&P 724-44 |
| Supersedes:<br>N/A            |                                  | Page 1 of 13   |

Companies Affected:

|                                     |   |   |
|-------------------------------------|---|---|
| <input type="checkbox"/> NIPSCO     | <input checked="" type="checkbox"/> CGV | <input type="checkbox"/> CMD            |
| <input type="checkbox"/> NIFL       | <input checked="" type="checkbox"/> CKY | <input checked="" type="checkbox"/> COH |
| <input type="checkbox"/> Kokomo Gas | <input type="checkbox"/> CMA            | <input type="checkbox"/> CPA            |

**REFERENCE**     None

**1. GENERAL**

A buried high-pressure regulator installation to reduce the operating pressure in a customer service line may be utilized for one of the following reasons:

- a. When the service regulator is located inside and there is no alternate location outside the residence or occupied structure to install the high-pressure service regulator above ground
- b. When it is necessary, because of the pressure limitations of the customer service line, to reduce the pressure between the property line and the service regulator installed at the building wall, and there is no alternate location at the property line.

This procedure for the installation of buried high-pressure service regulators is limited to systems with a Maximum Allowable Operating Pressure (MAOP) of at least 10 psig but not more than 125 psig. For buried regulator installations on systems with MAOPs over 125 psig, contact the Service Section of the Gas Supply and Services Department.

The buried high-pressure service regulator(s) shall be initial cut regulator(s) only and should not be installed on piping systems with known gas quality problems.

**2. DESIGN CONSIDERATIONS**

**2.1 Regulator Specifications**

Regulators that are approved for direct burial shall have a screwed valve body made of malleable or ductile iron and a diaphragm case made of cast iron or other approved corrosion resistive materials. The regulator shall be rated by the manufacturer as being suitable for the maximum allowable operating pressure of the pipeline. Only those regulators listed in Exhibit A are approved for buried installations.

*This document is considered CONTROLLED only when viewed electronically on the Company's intranet. Printed or other electronic copies may not be current, and the intranet version should be used to verify.*



Distribution Operations

|                               |                                  |  |
|-------------------------------|----------------------------------|--|
| Effective Date:<br>11/15/1984 | <b>Buried Service Regulators</b> | Standard Number:<br><b>GS 6400.440(CG)</b><br>P&P 724-44 |
| Supersedes:<br>N/A            |                                  | Page 2 of 13   |

**2.2 Selecting the Number of H.P. Service Regulators to Be Installed**

When the design pressure on the main is between 10 psig and 60 psig, a single 1 inch buried, high-pressure service regulator is required.

When the design pressure on the main is between 60 psig and 125 psig, two 1 inch buried, high-pressure service regulators are required.

**2.3 Pressure Setting**

The outlet pressure of single buried high-pressure service regulators shall be set at 10 psig or less. If two buried high-pressure service regulators are installed, the outlet pressure of the first cut regulator shall be set at 25 psig or less and the outlet pressure of the second cut regulator shall be set at 10 psig or less.

**3. INSTALLATION REQUIREMENTS**

**3.1 Cathodic Protection**

All buried regulators shall be coated with an approved protective coating and shall be cathodically protected.

**3.2 Valves**

Buried regulators shall have a provision for positive shut-off both immediately upstream and downstream of the buried regulator(s). The upstream shut-off provides a means of shutting off the gas so the buried regulator may be removed for repair or replacement. The downstream shut-off provides a means by which the buried regulator can be isolated from the customer's service line so that the customer service line may be tested from the meter setting with-out testing against the buried regulator. A curb box shall be installed on all valves.

**3.3 Methods for Venting Buried Regulators**

Buried regulators may be installed using an atmospheric tank as shown in Exhibit B or by the use of a check valve installed in the vent opening of the regulator as shown in Exhibit C.

**3.4 Pressure Test Plug**

A pressure test plug, as shown in the Material Catalog Section IX "Miscellaneous," shall be installed on the meter valve immediately upstream of the service regulator.



Distribution Operations

|                               |                                  |  |
|-------------------------------|----------------------------------|--|
| Effective Date:<br>11/15/1984 | <b>Buried Service Regulators</b> | Standard Number:<br><b>GS 6400.440(CG)</b><br>P&P 724-44 |
| Supersedes:<br>N/A            |                                  | Page 3 of 13   |

The 1/8 inch plug shall be removed from the test port on the valve and replaced with a test plug as shown in Exhibit D.

**3.5 Buried Regulator Tag**

In order to alert operating personnel that buried service regulator(s) are installed, it is necessary to attach a Buried Regulator Tag.

A Buried Regulator Tag shall be fastened to the piping at the final cut service regulator (see Exhibit E). Buried Regulator Tags may be obtained from the CDC Stationery Warehouse, 4188 Fisher Road, Columbus, Ohio 43228.

**4. RECORDING BURIED SERVICE REGULATOR(S) INSTALLATIONS**

**4.1 General**

A buried service regulator installation must be recorded in the Property Records of the Company as well as recording the installation in the Customer Information System (CIS).

**4.2 Recording the Fixed Capital Installation**

Buried Service Regulator(s) installations are recorded in the Continuing Property Records of the Company in accordance with [GS 6400.080\(CG\)](#) "Accounting for Low Pressure Meter and Regulator Installations."

**4.3 Recording the Installation in the CIS**

The Customer Meter-Service Order, Forms C-1555 or C-2045 (See Exhibit F), shall be the document used for coding Buried Service Regulator(s) installations into the CIS.

Service personnel will indicate a "BR" in the Buried Regulator blank on Forms C-1555 or C-2045 as shown on Exhibit F. A "BR" will also be printed at this location on Form C-2045 whenever future orders are printed by the computer.

Customer Accounting personnel will code (See Exhibit G) the installation into the CIS in accordance with applicable procedures.

The Special Code digit will appear on the Premises History Register (microfiche) and on the CIS Teleprocessing Screens.



Distribution Operations

|                               |                                  |  |
|-------------------------------|----------------------------------|--|
| Effective Date:<br>11/15/1984 | <b>Buried Service Regulators</b> | Standard Number:<br><b>GS 6400.440(CG)</b><br>P&P 724-44 |
| Supersedes:<br>N/A            |                                  | Page 4 of 13   |

**4.4 Service Line Data System (SLDS) Output**

The Special Code, Field CMR 0082, will be sent from the CIS to the SLDS by the Data Center for Buried Service Regulator Installations and the letters "BR" will be printed on Output Reports SL3301 and SL3401 as shown on Exhibit H.

When pre-printed Service Line Orders, Form C-1923, are prepared by the Data Center the letters "BR" will be printed as shown on Exhibit I.





**Gas Standard**

Distribution Operations

|                               |                                  |  |
|-------------------------------|----------------------------------|--|
| Effective Date:<br>11/15/1984 | <b>Buried Service Regulators</b> | Standard Number:<br><b>GS 6400.440(CG)</b><br>P&P 724-44 |
| Supersedes:<br>N/A            |                                  | Page 5 of 13   |

**EXHIBIT A**

Regulators Approved For Buried Installations

| <u>Manufacturer</u> | <u>Model</u> | <u>Orifice</u> | <u>Spring Color</u> | <u>Outlet Pressure Range</u> |
|---------------------|--------------|----------------|---------------------|------------------------------|
| Rockwell            | 041-C        | 1/8"           | Yellow              | 3-12 psig.                   |
| Rockwell            | 041-C        | 1/8"           | Aluminum            | 10-25 psig.                  |
| Sprague             | B-35N        | 1/8"           | Brown               | 3-5 psig.                    |
| Sprague             | B-35N        | 1/8"           | Green               | 10-20 psig.                  |
| Sprague             | B-35N        | 1/8"           | Black               | 15-25 psig.                  |
| Fisher              | 621          | 1/8"           | Red                 | 5-15 psig.                   |
| Fisher              | 621          | 1/8"           | Cadmium             | 10-25 psig.                  |
| Fisher              | 621          | 1/8"           | Blue                | 10-35 psig.                  |

Note:

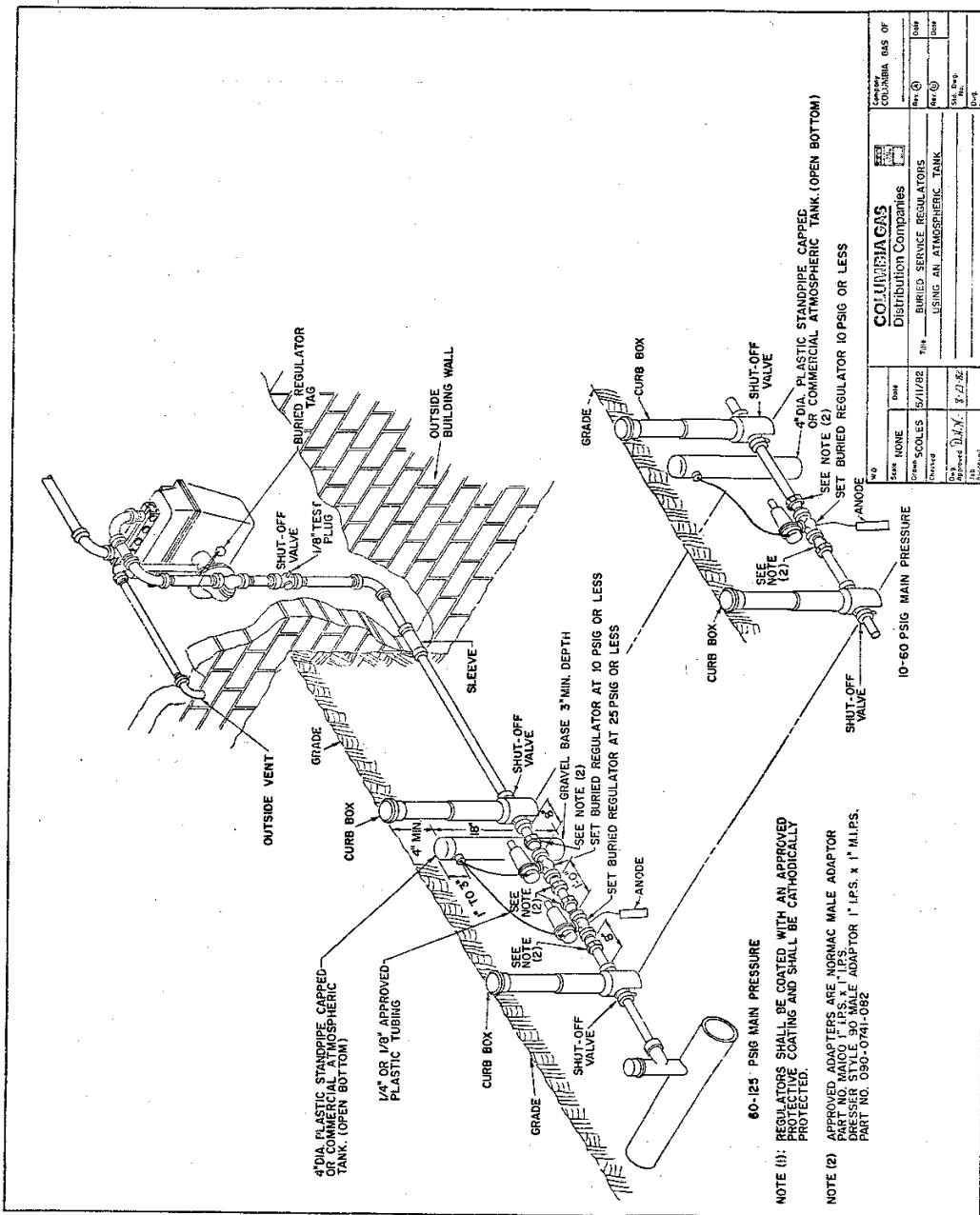
When service is provided from a CDC high-pressure main only and it is necessary to obtain a required capacity, the orifice size may be increased providing the relief capacity of the final cut service regulator can limit the downstream pressure to (1) PSIG or less.



Distribution Operations

|                               |                                    |  |
|-------------------------------|------------------------------------|--|
| Effective Date:<br>11/15/1984 | <h1>Buried Service Regulators</h1> | Standard Number:<br><b>GS 6400.440(CG)</b><br>P&P 724-44 |
| Supersedes:<br>N/A            |                                    | Page 6 of 13   |

EXHIBIT B



|     |         |        |             |
|-----|---------|--------|-------------|
| NO. | DATE    | BY     | DESCRIPTION |
| 1   | 8/11/82 | SCALES | REVISED     |
| 2   | 8/21/82 | D.A.N. | REVISED     |

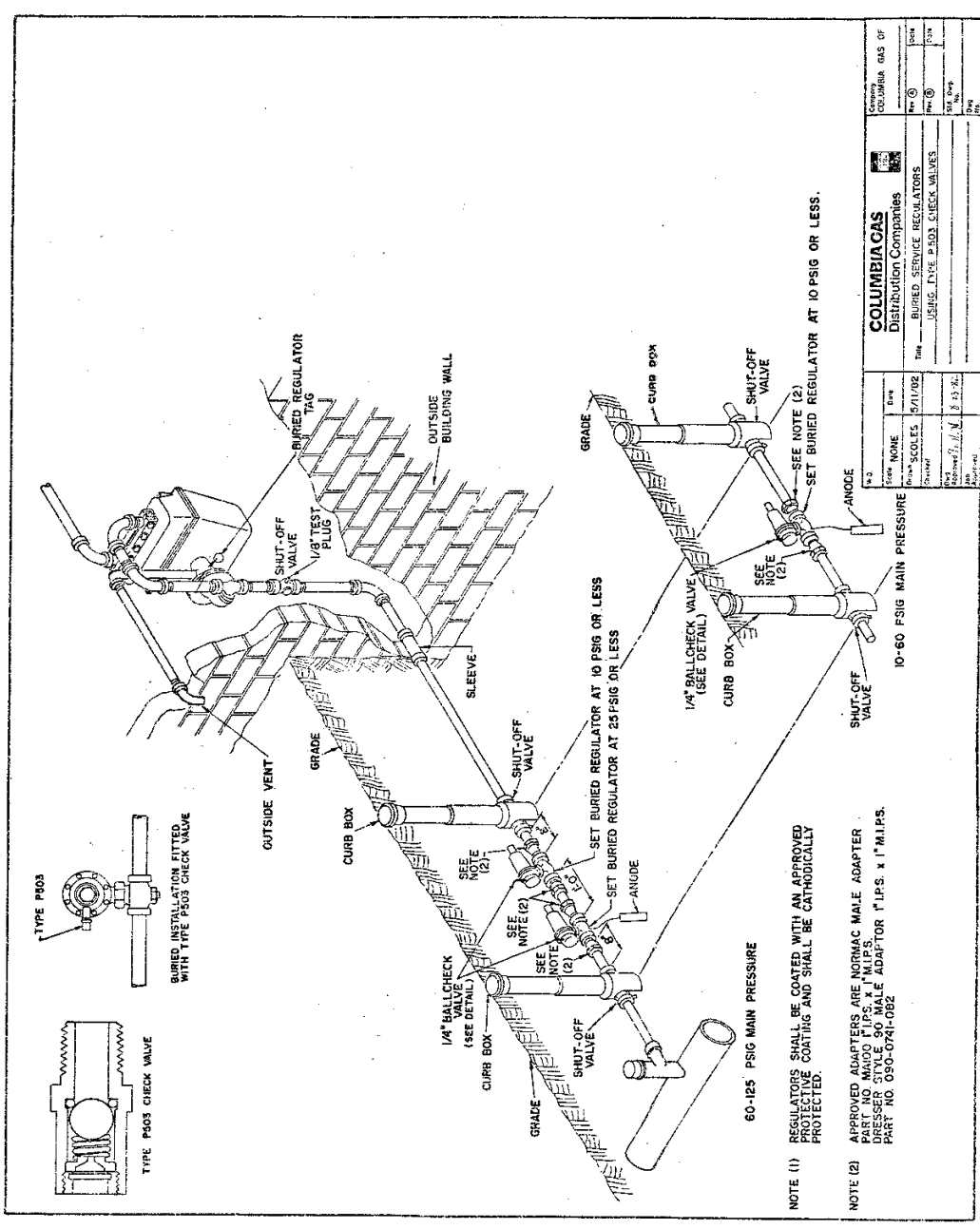
COLUMBIA GAS Distribution Companies  
 TYPE: BURIED SERVICE REGULATORS  
 USING AN ATMOSPHERIC TANK  
 COLUMBIA GAS OF  
 REV. (A)  
 REV. (B)  
 DATE  
 DATE



Distribution Operations

|                                       |                                    |   |
|---------------------------------------|------------------------------------|---|
| <p>Effective Date:<br/>11/15/1984</p> | <h1>Buried Service Regulators</h1> | <p>Standard Number:<br/><b>GS 6400.440(CG)</b><br/>P&amp;P 724-44</p> |
| <p>Supersedes:<br/>N/A</p>            |                                    | <p>Page 7 of 13</p>   |

EXHIBIT C

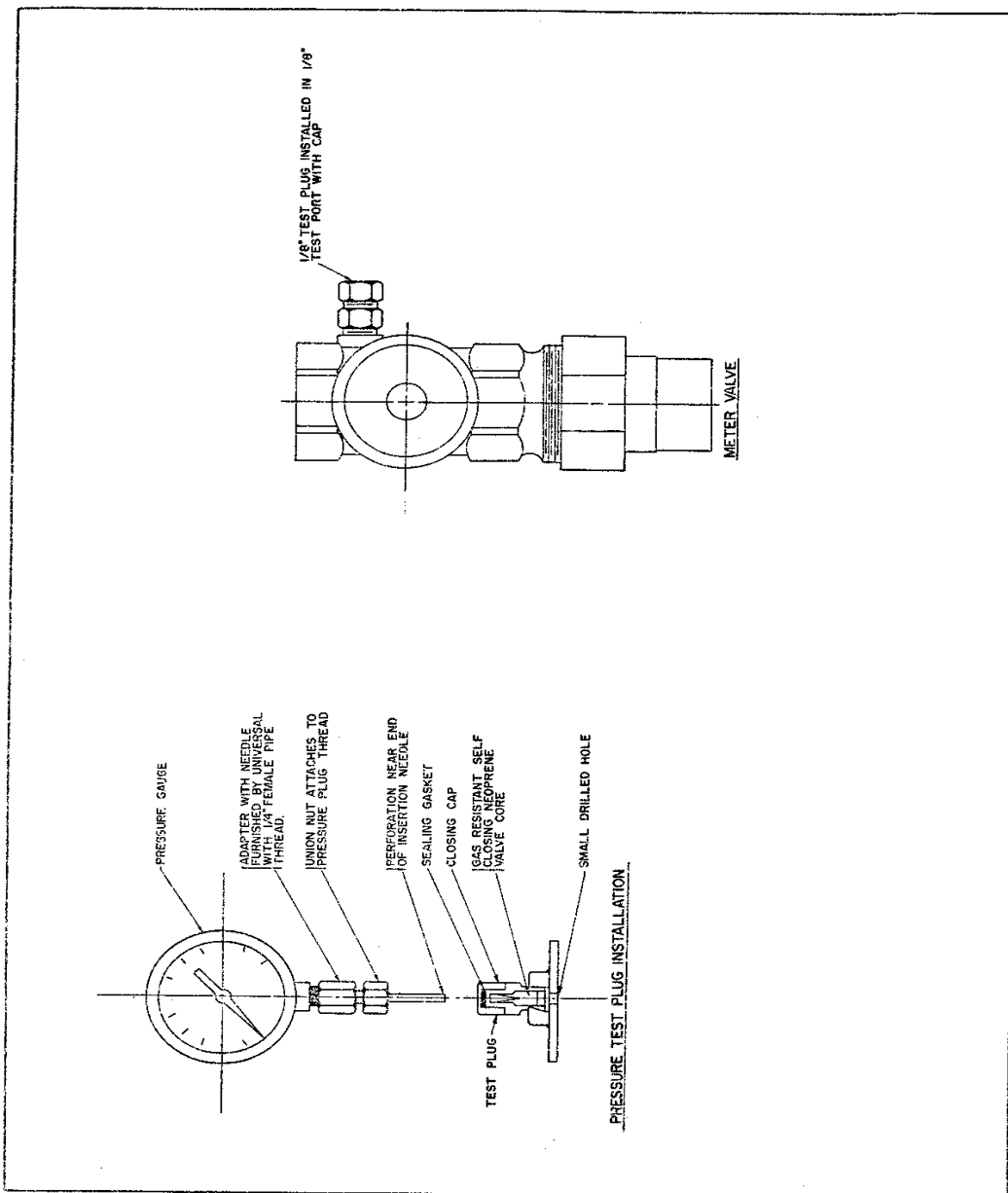




Distribution Operations

|                               |                                  |  |
|-------------------------------|----------------------------------|--|
| Effective Date:<br>11/15/1984 | <b>Buried Service Regulators</b> | Standard Number:<br><b>GS 6400.440(CG)</b> |
| Supersedes:<br>N/A            |                                  | P&P 724-44                                 |
|                               |                                  | Page 8 of 13                               |

EXHIBIT D

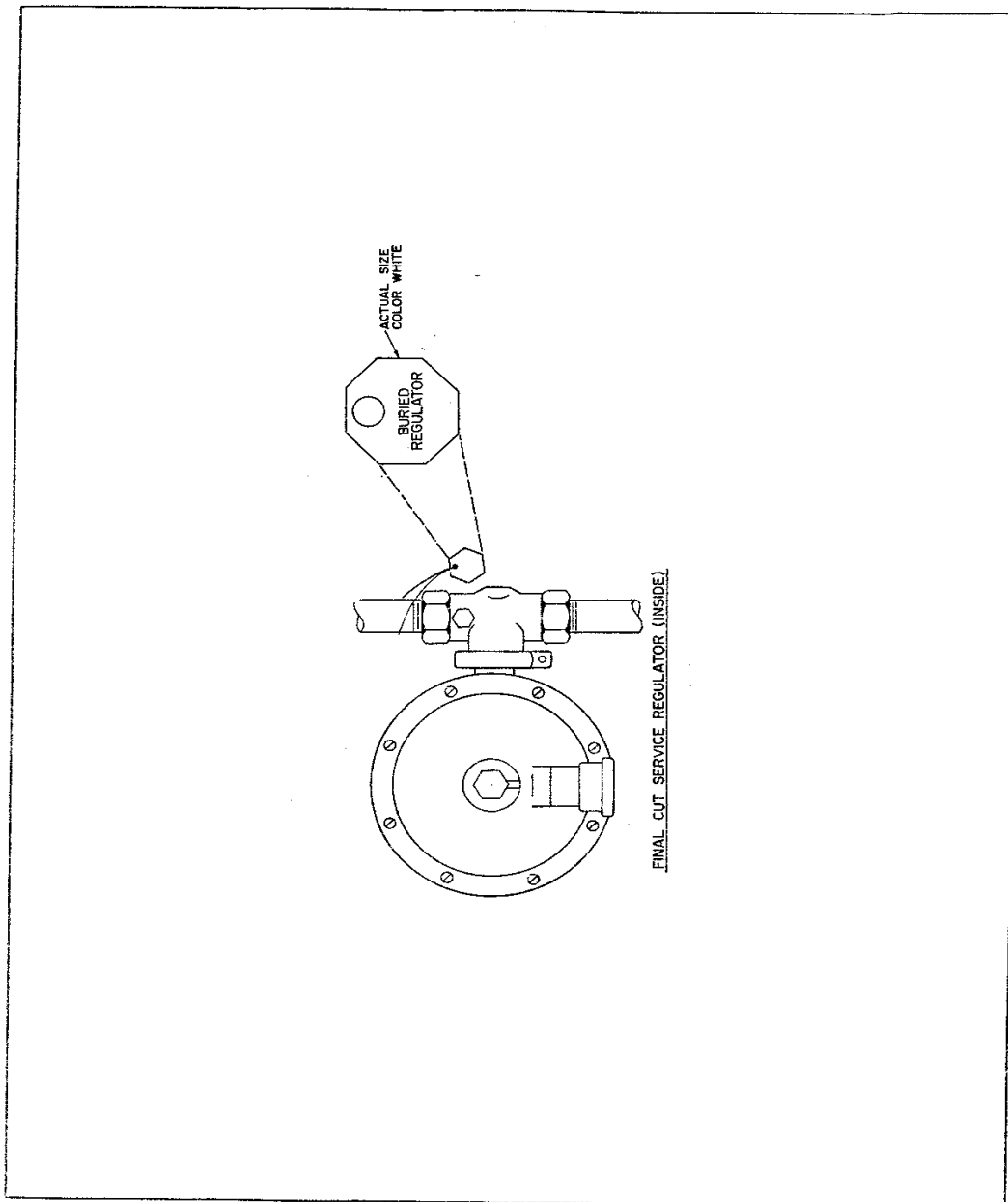




Distribution Operations

|                               |                                  |  |
|-------------------------------|----------------------------------|--|
| Effective Date:<br>11/15/1984 | <b>Buried Service Regulators</b> | Standard Number:<br><b>GS 6400.440(CG)</b> |
| Supersedes:<br>N/A            |                                  | P&P 724-44                                 |
|                               |                                  | Page 9 of 13                               |

EXHIBIT E





Gas Standard

Distribution Operations

|                               |                                  |  |
|-------------------------------|----------------------------------|--|
| Effective Date:<br>11/15/1984 | <b>Buried Service Regulators</b> | Standard Number:<br><b>GS 6400.440(CG)</b><br>P&P 724-44 |
| Supersedes:<br>N/A            |                                  | Page 10 of 13  |

EXHIBIT F

| FORM C 1555 CSD (6-89) COLUMBIA GAS DISTRIBUTION COMPANIES CUSTOMER METER-SERVICE ORDER  |           |                     |   |                  |   |   |   |                     |  |                  |   |              |
|--|-----------|---------------------|---|------------------|---|---|---|---------------------|--|------------------|---|--------------|
| SERVICE ADDRESS (NUMBER-STREET)  |           |                     | CITY-STATE  |                  | ZIP CODE  | PSID  | SEQ. NO.  | SADC                | TELEPHONE NO.  | TYPE DT          | ORDER NUMBER  |              |
|  |           |                     |   |                  |   |   |   |                     |  |                  | <b>014314 x</b>   |              |
| CUSTOMER NAME  |           |                     | PLACE OF EMPLOYMENT   |                  | BUSINESS TELEPHONE                                      |   | SPOUSE NAME   |                     |  |                  |   |              |
| MAILING ADDRESS (IF DIFFERENT FROM ABOVE)  |           |                     | CITY-STATE  |                  | ZIP CODE  | HAVE YOU HAD GAS SERVICE IN YOUR NAME BEFORE? |   |                     | <input type="checkbox"/> YES <input type="checkbox"/> NO |                  | YEAR DISCONNECTED                                       |              |
| PREVIOUS SERVICE ADDRESS (FOR DISCONNECT ORDER USE) (MOVING TO ADDRESS)  |           |                     | CITY-STATE  |                  |   |   |   |                     |  | ZIP CODE         |   |              |
| PROPERTY OWNER NAME (IF RENTING)   |           |                     | MAILING ADDRESS (NUMBER-STREET) (CITY-STATE-ZIP)  |                  |   |   |   |                     |  | TELEPHONE NUMBER |   |              |
| STUDENTS ONLY  |           |                     | PARENTS NAME  |                  | STREET ADDRESS  |   | CITY-STATE  |                     | ZIP CODE   |                  |   |              |
| NAMES OF OTHER PERSONS TO BE LIVING AT THE ABOVE SERVICE ADDRESS.  |           |                     |   |                  |   |   |   |                     | CUSTOMER'S SIGNATURE (OR AUTHORIZED REPRESENTATIVE)      |                  |   |              |
| I HEREBY AUTHORIZE GAS SERVICE TO BE ESTABLISHED IN MY NAME AT THIS ADDRESS AND AGREE TO PAY FOR SUCH SERVICE UNTIL DISCONTINUED BY MY REQUEST |           |                     |   |                  |   |   |   |                     |  |                  |   |              |
| DATE SERVICE DESIRED   | ISSUED BY | DATE AND TIME TAKEN | REQ. BY   | METER USAGE CODE | RENTAL CODE   | RENTAL AGR. CODE                              | ACCT METER STATUS   | ACCOUNTABILITY CODE |  |                  |   |              |
|  |           |                     |   |                  |   |   |   |                     |  |                  |   |              |
| IDENTIFICATION TWO REQUIRED  |           |                     | 1.  |                  | 2.  |   |   |                     | AMOUNT OWED  |                  | AMOUNT PAID   |              |
| <input type="checkbox"/> FINAL BILL ADDRESS  |           |                     |   |                  |   |   |   |                     |  |                  |   |              |
| <input type="checkbox"/> BDR   |           |                     |   |                  |   |   |   |                     |  |                  |   |              |
| GAS OFF  |           |                     | <input type="checkbox"/> STOP SEaled BLIND PLATE  |                  | CURB BOX LOCATION                                       |   | <input type="checkbox"/> TRANSFER OF BILLING NO PRESSURE TEST NECESSARY, VISUAL INSPECTION ONLY |                     |  |                  |   |              |
| <input type="checkbox"/> METER CURB  |           |                     |   |                  |   |   |   |                     |  |                  | GAS DETECTOR TESTS                                      |              |
| GAS ACCOUNTABILITY   |           |                     | <input type="checkbox"/> CDC <input type="checkbox"/> TCO <input type="checkbox"/> CHC                            |                  | CDC MAIN PRESS/TCO PIPELINE FUNCTION                    |   | TEST  | PRESSURE            | TIME   | LEAK             | OK  |              |
| <input type="checkbox"/> CDC <input type="checkbox"/> TCO <input type="checkbox"/> CHC   |           |                     |   |                  |   |   | HOUSE LINE  |                     |  |                  |   | LEAK OK NA   |
| MAIN/PIPELINE OWNED BY   |           |                     | <input type="checkbox"/> CDC <input type="checkbox"/> TCO <input type="checkbox"/> CHC                            |                  | TCO PIPELINE NO.  |   | SERVICE LINE  |                     |  |                  |   |              |
| <input type="checkbox"/> CDC <input type="checkbox"/> TCO <input type="checkbox"/> CHC   |           |                     |   |                  |   |   | SERVICE ENTR.   |                     |  |                  |   |              |
| BURIED REG. (Circled BR)   |           |                     | SIC CODE  |                  | COMMUNITY NAME  |   | MTR. DIAL SIZE  |                     |  |                  |   |              |
| GAS RANGE  |           |                     | WTR. HTR. GRILL   |                  | GAS A/C CENT HEAT                                       |   | GAS REF. GAS DRYER  |                     | OTHER GAS APPLIANCE                                      |                  | OTHER GAS APPLIANCE                                     |              |
| <input type="checkbox"/> NA <input type="checkbox"/> CN  |           |                     | <input type="checkbox"/> NA <input type="checkbox"/> CN   |                  | <input type="checkbox"/> NA <input type="checkbox"/> CN |   | <input type="checkbox"/> NA <input type="checkbox"/> CN   |                     | <input type="checkbox"/> NA <input type="checkbox"/> CN  |                  | <input type="checkbox"/> NA <input type="checkbox"/> CN |              |
| EMERGENCY CALLS (TIME)   |           |                     | SERVICEMAN'S SIGNATURE  |                  | TIME ARRIVED  |   | TIME COMPLETED  |                     | DATE COMPLETED   |                  |   |              |
| RECEIVED AM PM   |           |                     | ARRIVED AM PM   |                  | MADE SAFE AM PM   |   |   |                     | AM PM  |                  | AM PM   |              |
| METER SET DATE   |           |                     | <input type="checkbox"/> OUT <input type="checkbox"/> OFF <input type="checkbox"/> IN <input type="checkbox"/> ON |                  | KIND/SIZE CODE  |   | NUMBER  |                     | READING  |                  | REASON FOR CHANGE                                       |              |
|  |           |                     |   |                  |   |   |   |                     |  |                  | NO. OF DIALS MANFOLDED                                  |              |
| REPORT:  |           |                     |   |                  |   |   |   |                     |  |                  | ACCOUNT CLASSIFICATION                                  |              |
|  |           |                     |   |                  |   |   |   |                     |  |                  | CO. BLD. GEN. LEO. AUX. SUBSID. OTHER                   |              |
|  |           |                     |   |                  |   |   |   |                     |  |                  | FPCC PRESS. TYPE METER CD. METER READING INSTRUC. CODES |              |
| CONSUMPTION HISTORY  |           |                     |   |                  |   | INSTRUCTIONS:                                 |   |                     |  |                  |   |              |
| CURRENT YEAR   |           |                     | PREVIOUS YEAR   |                  |   |   |   |                     |  |                  |   |              |
| PER  | CONS      | CODE                | DAYS  | PER              | CONS  | CODE  | DAYS  |                     |  |                  |   |              |
| CUR  |           |                     |   |                  |   |   | 12TH  |                     |  |                  |   |              |
| 1ST  |           |                     |   |                  |   |   | 13TH  |                     |  |                  |   |              |
| 2ND  |           |                     |   |                  |   |   | 14TH  |                     |  |                  |   |              |
| 3RD  |           |                     |   |                  |   |   |   |                     |  |                  |   |              |
| 4TH  |           |                     |   |                  |   |   |   | KIND SIZE CD        | NUMBER   | READING          | READ DATE   | MOCALC DIALS |
| 5TH  |           |                     |   |                  |   |   |   | LOC                 | CR YEAR  | DEP. CODE        | CR CODE   | COMM NO.     |
| TYPE DE  | ORDER NO. | UNIT                | BOOK  | ACCOUNT          | TYPE ID   | LO  | FORMER FUEL CODE  | MKT. REENTRY CODE   | ILEA/SURCHARGE NO.                                       | REENTRY DATE     | ENTERED BY  |              |



Distribution Operations

|                               |                                  |  |
|-------------------------------|----------------------------------|--|
| Effective Date:<br>11/15/1984 | <b>Buried Service Regulators</b> | Standard Number:<br><b>GS 6400.440(CG)</b><br>P&P 724-44 |
| Supersedes:<br>N/A            |                                  | Page 11 of 13  |

**EXHIBIT G**

FIELD NUMBER CMR 0082

FIELD NAME Special Code

SEGMENT Customer Master Record

DEFINITION A 1-digit numeric code showing the special code assigned to the account.

Code

- 0 None
- 1 One Buried Regulator is installed in the Customer Service Line
- 2 An Agreement for Conditionally Limited Time Gas Service, Form C-2230, is on file for this customer
- 3 Codes 1 and 2 combined
- 4 Two Buried Regulators are installed in the Customer Service Line
- 5 Codes 2 and 4 combined
- 6, 7, 8, 9 Credit and Collection  
 (Description is determined by each office or District to identify conditions unique to their location. Will not post over a 1, 2, 3, 4 or 5).







Gas Standard

Distribution Operations

|                               |                                  |  |
|-------------------------------|----------------------------------|--|
| Effective Date:<br>11/15/1984 | <b>Buried Service Regulators</b> | Standard Number:<br><b>GS 6400.440(CG)</b><br>P&P 724-44 |
| Supersedes:<br>N/A            |                                  | Page 13 of 13  |

EXHIBIT I

COLUMBIA GAS DISTRIBUTION COMPANIES  
**SERVICE LINE ORDER**

FORM C 3923 (6-81)  
34338

SURVEY     REPAIR     REPLACE     NEW     ABANDON

SERVICE ADDRESS (1)    7665 LINCOLN HY    SER. CITY (2)    CRE    09-05-29001    26

CDC PSID NUMBER (3)    30J289775    CDC CURB BOX LOCATION OR TCO INVENTORY STATION NO. (4)    6CFFB    411B    LENGTH SER. (5)    56    SERVICE TYPE (6)    12S

DATE INSTALLED (7)    1955    MT (8)    81    REPAIR YR    LCB    KIND (9)    2954-H    MAIN CODE OR LINE NUMBER (11)    4GS 4ANCU    OPER PRES (12)    LP    SP. (13)

TAKING DIST. NO. (14)    BR    170220    MIN (17)    CUSTOMER VALVE LOCATION (18)    METER VALVE    REASON FOR WORK

TAX DISTRICT NAME    DATE OF REQUEST    DATE ISSUED    SKETCH:

GEOGRAPHIC INFORMATION BETWEEN \_\_\_\_\_ AND \_\_\_\_\_

CUSTOMER OR APPLICANT    THE HUDDLE

SUBDIVISION ADDRESS    R2 W MAIN ST

LOT NUMBER    SERVICE DEPTH    PROPOSED LOCATION

INSTALLED BY    COMPANY REP\*

| TEST DATA        | PRESSURE | TIME | TYPE | DATE | SIGNATURE |
|------------------|----------|------|------|------|-----------|
| COMPANY SERVICE  |          |      |      | / /  |           |
| CUSTOMER SERVICE |          |      |      | / /  |           |
| HOUSE LINES      |          |      |      | / /  |           |

\*USE REVERSE SIDE FOR REMARKS

818 2215625

Labels and Annotations:

- GCDLO (Group, Company, District, Local Office) - points to 34338
- Output Code - points to 7A
- Account Number - points to 09-05-29001
- Community No. - points to 26
- Old Address - points to 7665 LINCOLN HY
- Buried Regulator - points to METER VALVE
- Meter Kind/Size Code - points to 4GS 4ANCU
- Meter Serial No. - points to 818 2215625



Distribution Operations

|                               |   |  |
|-------------------------------|---|--|
| Effective Date:<br>05/30/1986 | <b>Transfer of Meters Between TCO<br/>and CDC</b> | Standard Number:<br><b>GS 6400.450(CG)</b><br>P&P 724-45 |
| Supersedes:<br>N/A            |   | Page 1 of 5  |

Companies Affected:

|                                     |   |   |
|-------------------------------------|---|---|
| <input type="checkbox"/> NIPSCO     | <input checked="" type="checkbox"/> CGV | <input checked="" type="checkbox"/> CMD |
| <input type="checkbox"/> NIFL       | <input checked="" type="checkbox"/> CKY | <input checked="" type="checkbox"/> COH |
| <input type="checkbox"/> Kokomo Gas | <input type="checkbox"/> CMA            | <input checked="" type="checkbox"/> CPA |

**REFERENCE** TCO Policy & Procedure Chapter Tab No. 9, Registry No. 46 Titled Columbia Gas Transmission Corp. (TCO) and Columbia Gas Distribution Companies (CDC).

**1. GENERAL**

Meters in Columbia Gas Distribution Companies (CDC) owned measuring stations are subject to audit by the State Regulatory Commissions. When an audit reveals a discrepancy between the serial number of a meter on CDC Continuing Property Records and the meter physically located at the measuring station, CDC is not allowed to earn revenue on the cost of the meter. To help resolve this problem, the following procedure shall be followed.

**2. PROCEDURE**

Whenever possible, install meters or turbine modules obtained from CDC stock in CDC owned measuring stations. CDC's Warehouseman or Service Supervisor will prepare the Material Transfer, Form C-74 (Exhibit A) to record this transaction (refer to [GS 6400.070\(CG\)](#) "Meter Records").

When installing a meter or module obtained from TCO stock in a CDC owned measuring station, a Material Transfer, Form No. 69MM7 (Exhibit B), will be prepared by TCO personnel listing the description, serial number, stock symbol number and price of meter or module. Copies of the Material Transfer shall be sent to the CDC Service Supervisor at the nearest CDC Service Center and to the CDC General Office, Columbus, Ohio, Attention: Supervisor, Continuing Property Records Section. TCO will be responsible for making the proper billing for the sale of the meter or module to CDC.

When a meter or module is removed from a CDC owned measuring station, the meter or module shall be taken to the nearest CDC Service Center. It shall be tagged with the appropriate CDC Meter Record Card (Exhibit C) indicating number and name of the measuring station from which it was removed. The warehouseman or service supervisor will be responsible for preparing the Material Transfer and arrange to have the removed meter

*This document is considered CONTROLLED only when viewed electronically on the Company's intranet. Printed or other electronic copies may not be current, and the intranet version should be used to verify.*



Distribution Operations

|                               |   |  |
|-------------------------------|---|--|
| Effective Date:<br>05/30/1986 | <b>Transfer of Meters Between TCO<br/>and CDC</b> | Standard Number:<br><b>GS 6400.450(CG)</b><br>P&P 724-45 |
| Supersedes:<br>N/A            |   | Page 2 of 5  |

or module returned to the meter shop as soon as possible. This is particularly important in the case of turbine modules, where a quick turn around is required so that CDC can stay current with the scheduled bi-annual module change out program.

When turbine modules are shipped directly to or from the shop and the customer's measurement station, the meter shop superintendent/super-visor shall prepare the required Material Transfers.

In addition, the required Meter Equipment Change Report must be completed and processed in accordance with [GS 6400.170\(CG\)](#).



Gas Standard

Distribution Operations

|                               |   |  |
|-------------------------------|---|--|
| Effective Date:<br>05/30/1986 | <b>Transfer of Meters Between TCO<br/>and CDC</b> | Standard Number:<br><b>GS 6400.450(CG)</b><br>P&P 724-45 |
| Supersedes:<br>N/A            |   | Page 3 of 5  |

EXHIBIT A

REG. NO. 124-45

ACCOUNT OR WORK ORDER NO. Bolin Asphalt COLUMBIA GAS DISTRIBUTION COMPANIES Meter Investment

F 7-5-12280 MATERIAL TRANSFER T Coleraines Ohio

O LOCATION Edyria 1221 DIST Edyria 1221

M DATE March 14 19 86 LOCATION Edyria 1221

| SIZE | DESCRIPTION OF MATERIAL    | QUANTITY | STOCK SYMBOL NUMBER | UNIT PRICE | PER | AMOUNT |
|------|----------------------------|----------|---------------------|------------|-----|--------|
|      | <u>T-60 Turbine Module</u> |          |                     |            |     |        |
|      | <u>Mark T WP 125</u>       |          |                     |            |     |        |
|      | <u>S/N A-8906</u>          |          |                     |            |     |        |
|      | <u>1973</u>                |          |                     |            |     |        |

| XXXX   | TRANS CODE | LOC | XXXX   | ST | CO BLD | GEN LED | AUX  | SUBSID | OTHER | CODE | STORES OVER | AMOUNT     |
|--------|------------|-----|--------|----|--------|---------|------|--------|-------|------|-------------|------------|
| DEBIT  |            |     | DEBIT  |    |        | 101     | 1000 |        | 3850  |      |             |            |
| CREDIT |            |     | CREDIT |    |        | 101     | 1000 |        | 3850  |      |             | XXXXXX XXX |

ISSUED BY: Ken Jordan CHARGE ACCOUNT \_\_\_\_\_

MAT'L REC'D BY \_\_\_\_\_ DATE \_\_\_\_\_ 19 \_\_\_\_\_

USED FOR \_\_\_\_\_ TRANSFER NO. MT 4-2

Meter Transfer for Meter Removed

ACCOUNT OR WORK ORDER NO. Bolin Asphalt COLUMBIA GAS DISTRIBUTION COMPANIES Meter Investment

F 7-5-12280 MATERIAL TRANSFER T Edyria

O LOCATION Coleraines, Ohio 1221 DIST Edyria 1221

M DATE March 14 19 86 LOCATION Edyria 1221

| SIZE | DESCRIPTION OF MATERIAL    | QUANTITY | STOCK SYMBOL NUMBER | UNIT PRICE | PER | AMOUNT |
|------|----------------------------|----------|---------------------|------------|-----|--------|
|      | <u>T-60 Turbine Module</u> |          |                     |            |     |        |
|      | <u>Mark T WP 125</u>       |          |                     |            |     |        |
|      | <u>S/N E434</u>            |          |                     |            |     |        |
|      | <u>1969</u>                |          |                     |            |     |        |

| XXXX   | TRANS CODE | LOC | XXXX   | ST | CO BLD | GEN LED | AUX  | SUBSID | OTHER | CODE | STORES OVER | AMOUNT     |
|--------|------------|-----|--------|----|--------|---------|------|--------|-------|------|-------------|------------|
| DEBIT  |            |     | DEBIT  |    |        | 101     | 1000 |        | 3810  |      |             |            |
| CREDIT |            |     | CREDIT |    |        | 101     | 1000 |        | 3810  |      |             | XXXXXX XXX |

ISSUED BY: Ken Jordan CHARGE ACCOUNT \_\_\_\_\_

MAT'L REC'D BY \_\_\_\_\_ DATE \_\_\_\_\_ 19 \_\_\_\_\_

USED FOR \_\_\_\_\_ TRANSFER NO. MT 4-1

Meter Transfer for Meter Installed

Color - White  
Size 8 1/2" x 3 3/4"



Gas Standard

Distribution Operations

|                               |   |  |
|-------------------------------|---|--|
| Effective Date:<br>05/30/1986 | <b>Transfer of Meters Between TCO<br/>and CDC</b> | Standard Number:<br><b>GS 6400.450(CG)</b><br>P&P 724-45 |
| Supersedes:<br>N/A            |   | Page 4 of 5  |

**EXHIBIT B**

| CHANGE                     |   | MATERIAL TRANSFER               |                      |                 |             |        |                   |          |                 |       |        | CHANGE                                   |                    |                 |       |        |
|----------------------------|---|---------------------------------|----------------------|-----------------|-------------|--------|-------------------|----------|-----------------|-------|--------|--|--------------------|-----------------|-------|--------|
| Stock                      |   | COLUMBIA GAS TRANSMISSION CORP. |                      |                 |             |        |                   |          |                 |       |        | CVA NS 8-5-3969                          |                    |                 |       |        |
| LOCATION<br>St. Albans     |   | LOCATION<br>Strasburg           |                      |                 |             |        |                   |          |                 |       |        | LOCATION<br>Holsum Bakery<br>Augusta Co. |                    |                 |       |        |
| LOC NO<br>0561             |   | LOC NO                          |                      |                 |             |        |                   |          |                 |       |        | LOC NO                                   |                    |                 |       |        |
| QTY                        | DESCRIPTION   | QUANTITY                        | STOCK SYMBOL NO      | PRICE           | AMOUNT      |        |                   |          |                 |       |        | AMOUNT                                   |                    |                 |       |        |
| B"                         | T-60 Turbine Module, Mark II,<br>W.P. 17B, S/N 80248, Year 1980 | 1                               | 51 38235             | 1,933.27        | SR          |        |                   |          |                 |       |        |  |                    |                 |       |        |
| RESERVE                    |   | LOC NO                          | QUANTITY             | STOCK SYMBOL NO | PRICE       | AMOUNT | LOC NO            | QUANTITY | STOCK SYMBOL NO | PRICE | AMOUNT | LOC NO                                   | QUANTITY           | STOCK SYMBOL NO | PRICE | AMOUNT |
|                            |   | 38                              | 107                  | 889             | 1985        | 3810   | 71                |          |                 |       |        |  |                    |                 |       |        |
| PREPARED BY<br>Sam Samples |   | DATE<br>05/30/85                | APPROVAL BY (IF REQ) |                 | RECEIVED BY | DATE   | TRANS TYPE<br>F-1 |          | XXXXXXXXXX      |       |        |  | TRANS NO<br>N/A 60 |                 |       |        |

This Material Transfer shows a turbine meter module transferred from a TCO stock location to a CDC Measuring Station in Virginia. Note that the Credit portion (CR) is not filled out. The reason for this is that the MIS computer system automatically does this transaction by scanning the "Loc. No." and the "Trans Type" columns. The Debit portion (DR) must be filled out. This information is generally supplied by CDC personnel.

NOTE: TCO is also responsible for making the appropriate billing for the sale of this module to CDC.

NOTE: This exhibit is also shown in TCO's Policy and Procedure of the same title, chapter Tab No. 9, Registry No. 46.

Color - White  
 Size 8 1/2" x 3 3/4"



Gas Standard

Distribution Operations

|                               |   |  |
|-------------------------------|---|--|
| Effective Date:<br>05/30/1986 | <b>Transfer of Meters Between TCO<br/>and CDC</b> | Standard Number:<br><b>GS 6400.450(CG)</b><br>P&P 724-45 |
| Supersedes:<br>N/A            |   | Page 5 of 5  |

**EXHIBIT C**

|   |              |      |                          |                 |                    |               |       |
|---|--------------|------|--------------------------|-----------------|--------------------|---------------|-------|
| (SIDE 1)<br><br>METER NO.<br>KIND/SIZE<br>RECEIVED BY TRUCK NO.<br>DATE | METER NUMBER |      | FIELD OPER. LOCATION NO. | KIND/SIZE       | REASON FOR REMOVAL | LOCATION      | CLASS |
|   | UNIT         | BOOK | ACCOUNT NO.              | SERVICE ADDRESS |                    |               |       |
| METER REMOVED BY:   |              | DATE |                          | READING         |                    | KEYPUNCHED BY |       |
| OTHER DATA  |              |      |                          |                 |                    | VERIFIED BY   |       |

|   |                |                         |                        |                   |                         |                        |
|---|----------------|-------------------------|------------------------|-------------------|-------------------------|------------------------|
| (SIDE 2)<br><br>COLUMBIA GAS DISTRIBUTION COMPANIES<br>COLUMBIA GAS OF PENNSYLVANIA, INC.<br><br>FORM C 1745 CSD (1-1-80) | DIAPHRAGM TYPE | CLASS OF REPAIR         | YEAR OF PUR. LAST      | YR. LAST REPAIRED | INTEST CONDITION        | DATE OF PRESENT INTEST |
|   | INTEST PROOF % | OUTTEST PROOF %         | INTEST METERMAN NUMBER | DATE              | OUTTEST METERMAN NUMBER | DATE                   |
| OTHER DATA  |                | OUTTEST METERMAN NUMBER |                        | DATE              |                         |                        |

Color - Varies by State  
Size 7 1/2" x 3"  
Front & Back Side (Side 1 & 2) As Shown



Distribution Operations

|                               |                                     |  |
|-------------------------------|-------------------------------------|--|
| Effective Date:<br>01/01/2013 | <b>Use of Red Tag on Appliances</b> | Standard Number:<br><b>GS 6500.010</b> |
| Supersedes:<br>N/A            |                                     | Page 1 of 5                            |

Companies Affected:

|                                 |   |   |
|---------------------------------|---|---|
| <input type="checkbox"/> NIPSCO | <input type="checkbox"/> CGV            | <input type="checkbox"/> CMD            |
|                                 | <input checked="" type="checkbox"/> CKY | <input checked="" type="checkbox"/> COH |
|                                 | <input type="checkbox"/> CMA            | <input type="checkbox"/> CPA            |

**REFERENCE** None

**1. GENERAL**

In the event an unsafe condition is discovered on a customer's appliance, the employee shall turn off the gas supply to the appliances, and complete Form C524-3, "Appliances Shut-off Notice," (Red Tag) Exhibit A. The completed "red tag" shall be attached to the valve or appliance which has been turned off.

In addition to leaving the red tag, the employee shall inform the customer why the appliance was turned off and to contact a qualified agency to correct the unsafe condition. This communication to the customer may be verbally or in writing (in addition to the red tag). The employee should avoid using abbreviations, if possible.

The customer shall be warned not to use the appliance until the required repairs have been made by a qualified repairman. It is the customer's responsibility to arrange for such repairs to be made.

**2. EXAMPLES OF UNSAFE CONDITIONS**

The following are examples of unsafe conditions which may be encountered:

- a. Gas leak in the appliance that cannot be readily repaired by the employee.
- b. An unlisted connector.
- c. Defective or plugged vent pipe or chimney.
- d. Not vented, improperly vented or vented into a chimney of inadequate size or height.
- e. Improper combustion which cannot be readily corrected by minor cleaning or adjustment.
- f. Insufficient make-up air to support combustion and for proper ventilation.
- g. Inoperative safety pilot or absence of required safety pilot.
- h. Inoperative, or absence of required safety devices, such as high limit controls, pressure and temperature relief valve, low water cut off, etc.

*This document is considered CONTROLLED only when viewed electronically on the Company's intranet. Printed or other electronic copies may not be current, and the intranet version should be used to verify.*



Distribution Operations

|                               |                                     |  |
|-------------------------------|-------------------------------------|--|
| Effective Date:<br>01/01/2013 | <b>Use of Red Tag on Appliances</b> | Standard Number:<br><b>GS 6500.010</b> |
| Supersedes:<br>N/A            |                                     | Page 2 of 5                            |

- i. Defective or improper wiring which might cause an unsafe condition.
- j. Burned out, cracked or clogged heat exchangers which permit products of combustion to escape from the combustion chamber or flue system.
- k. Improperly installed appliances such as, insufficient clearance from combustible material, improperly located appliance shut-off valve, return air supply taken from the same area as combustion and ventilation air, or appliances installed in a small confined space, such as a bathroom or bedroom with inadequate combustion air.

**3. RECORDS**

**3.1 DIS Order or MDT Completion Form**

The employee shall record on the DIS Order, Exhibit B, or on the MDT completion form any information regarding the red tagging of an appliance.

**3.2 Premise Audit**

Form C-2997, "Premise Audit, "Exhibit C, or MDT completion form shall be completed and turned in with the DIS Order each time an appliance is red tagged. The Premise Audit forms shall then be forwarded to the Manager Market Research at the General Office for scanning (only if paper copy).

Equipment that is both red tagged and disconnected will be indicated on the Premise Audit form by marking both the "Not Connected" and the "Red Tag" columns or by placing a "G" code next to the appropriate appliance. The printed DIS Order will indicate this by printing a code of "RT/DC" next to each applicable appliance.



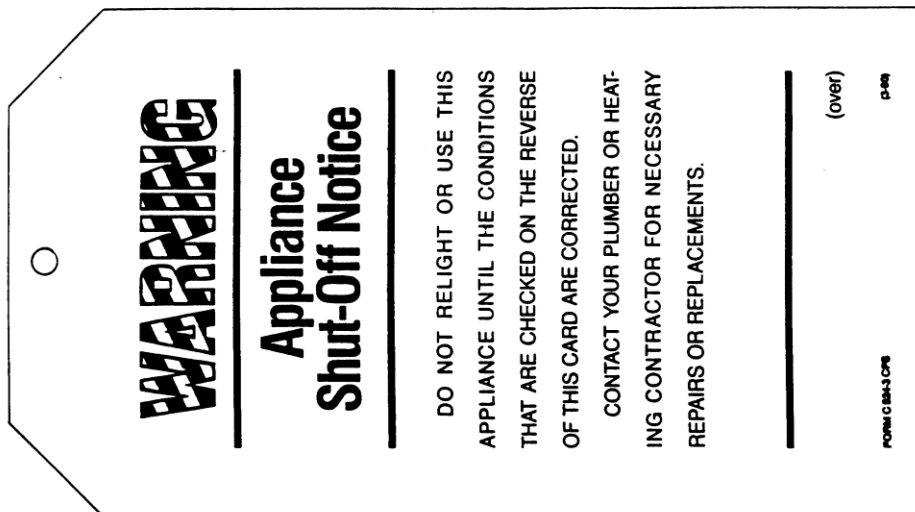


**Gas Standard**

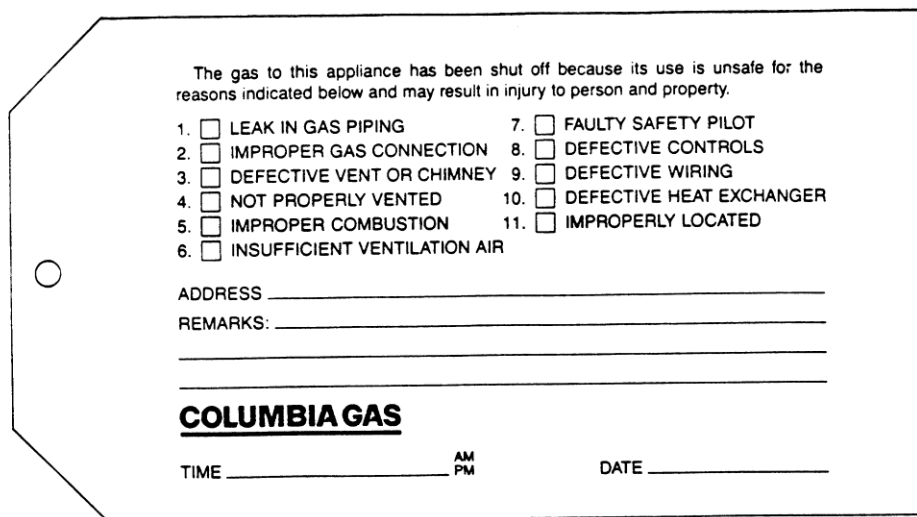
Distribution Operations

|                               |                                     |  |
|-------------------------------|-------------------------------------|--|
| Effective Date:<br>01/01/2013 | <b>Use of Red Tag on Appliances</b> | Standard Number:<br><b>GS 6500.010</b> |
| Supersedes:<br>N/A            |                                     | Page 3 of 5                            |

**EXHIBIT A**



Front  
Color - Red



Back



**Gas Standard**

Distribution Operations

|                               |                                     |  |
|-------------------------------|-------------------------------------|--|
| Effective Date:<br>01/01/2013 | <b>Use of Red Tag on Appliances</b> | Standard Number:<br><b>GS 6500.010</b> |
| Supersedes:<br>N/A            |                                     | Page 4 of 5                            |

**EXHIBIT B**

```

KY - DIS ORDER PAGE 1 OF 1 TAKEN 04/02/1996.1133 TO BE WORKED 04/02/1996

GEORGE JONES                FOR: SERVICE/REPRINT  ORDER TYPE: CM
216 AMANDA ST                PRINT SEQ # 00002 UN/BK 03/82 SADC E5
RUSSELL                      KY 411691313          ORDER SEQ # 10 DSK B  PSID 100239366
GREENUP                      COUNTY              OVERFLOW
PHONES:  HOME 614-460-1890    WORK                OTHER
ACC: INACTIVE RESIDENTIAL HEAT  ACCT CLASS: 878-    -    -    -03211-    2631 0895122  -
RUSSELL
RUSSELL INDEPENDENT (S.D.)
M/L: A 32051017P 242 LP      .0    .0 040 24FFB          000000000
SL :                        00004 012P          00/00/71
EFV:  20FFB  2LRB          METER VALVE
CSL:                        000                00/00/00
MSA: ROCKWELL R-200          817 CKY 10-1988 2002  752289 DIA 4
      000200          0.2  OUTSIDE - RIGHT          CVD NO  0 00

PROPERTY RENTED-PROP OWNER INFO ON FILE  PRESS COMP CD IS 0  TEMP COMP CD IS 0
MTR RDG: _____ ON: _ CVO: _ MVD: _ REMV CD: _
* CALL CUSTOMER * LEAVE PACKET *
ORDER INSTR: PREVIOUS RED TAG CONDITION

BET STRS:                    &
CORNER STR:                  SUBDIV:
NEW MTR INFO: K&S  _____ SERIAL # _____ DIALS  ___ IN: _____ READ _____
APPL CONN: A-C ___ C HEAT ___ DRYER ___ GRILL ___ RANGE ___ W HEAT ___ OTHER _____
MKT APPL: HEAT RT/DC, WHEAT RT/DC, DRYER ST  , RANGE CN  ,

PREMISE AUDIT DATE: 01/31/1996
CUST ID # 1: _____ CUST ID # 2: _____
CUSTOMER SIGNATURE: _____ FURTHER ACTION REQUIRED: _ YES
REMARKS: _____

I HAVE FOLLOWED ALL APPLICABLE COMPANY PRACTICES,
POLICIES AND PROCEDURES IN COMPLETING THIS ORDER. SIGNED:
AR TM: _____ LV TM: _____ DATE: _____ 03/01 READING 0003000 MDS CALC: 0
    
```



**Gas Standard**

Distribution Operations

|                               |                              |  |
|-------------------------------|------------------------------|--|
| Effective Date:<br>01/01/2013 | Use of Red Tag on Appliances | Standard Number:<br><b>GS 6500.010</b> |
| Supersedes:<br>N/A            |                              | Page 5 of 5                            |

**EXHIBIT C**

## RESIDENTIAL PREMISE AUDIT

| PSID NUMBER |  |  |  |  |  |  |  |  |  |
|-------------|--|--|--|--|--|--|--|--|--|
|             |  |  |  |  |  |  |  |  |  |
|             |  |  |  |  |  |  |  |  |  |
|             |  |  |  |  |  |  |  |  |  |
|             |  |  |  |  |  |  |  |  |  |
|             |  |  |  |  |  |  |  |  |  |
|             |  |  |  |  |  |  |  |  |  |
|             |  |  |  |  |  |  |  |  |  |
|             |  |  |  |  |  |  |  |  |  |
|             |  |  |  |  |  |  |  |  |  |
|             |  |  |  |  |  |  |  |  |  |
|             |  |  |  |  |  |  |  |  |  |
|             |  |  |  |  |  |  |  |  |  |
|             |  |  |  |  |  |  |  |  |  |
|             |  |  |  |  |  |  |  |  |  |
|             |  |  |  |  |  |  |  |  |  |
|             |  |  |  |  |  |  |  |  |  |
|             |  |  |  |  |  |  |  |  |  |
|             |  |  |  |  |  |  |  |  |  |
|             |  |  |  |  |  |  |  |  |  |
|             |  |  |  |  |  |  |  |  |  |

| COMPLETION DATE |     |      |  |  |  |
|-----------------|-----|------|--|--|--|
| MO              | DAY | YEAR |  |  |  |
|                 |     |      |  |  |  |
|                 |     |      |  |  |  |
|                 |     |      |  |  |  |
|                 |     |      |  |  |  |
|                 |     |      |  |  |  |
|                 |     |      |  |  |  |
|                 |     |      |  |  |  |
|                 |     |      |  |  |  |
|                 |     |      |  |  |  |
|                 |     |      |  |  |  |
|                 |     |      |  |  |  |
|                 |     |      |  |  |  |
|                 |     |      |  |  |  |
|                 |     |      |  |  |  |
|                 |     |      |  |  |  |
|                 |     |      |  |  |  |
|                 |     |      |  |  |  |
|                 |     |      |  |  |  |
|                 |     |      |  |  |  |

| OFFICE LOCATION |  |  |  |  |  |
|-----------------|--|--|--|--|--|
|                 |  |  |  |  |  |
|                 |  |  |  |  |  |
|                 |  |  |  |  |  |
|                 |  |  |  |  |  |
|                 |  |  |  |  |  |
|                 |  |  |  |  |  |
|                 |  |  |  |  |  |
|                 |  |  |  |  |  |
|                 |  |  |  |  |  |
|                 |  |  |  |  |  |
|                 |  |  |  |  |  |
|                 |  |  |  |  |  |
|                 |  |  |  |  |  |
|                 |  |  |  |  |  |
|                 |  |  |  |  |  |
|                 |  |  |  |  |  |
|                 |  |  |  |  |  |
|                 |  |  |  |  |  |
|                 |  |  |  |  |  |

| EMPLOYEE NAME |  |
|---------------|--|
|               |  |
|               |  |

MARKING INSTRUCTIONS

• DO NOT USE FELT-TIPPED PENS

|  |   |
|--|---|
| INCORRECT MARKS  | CORRECT MARK  |
| <input type="checkbox"/> <input type="checkbox"/> <input type="checkbox"/> <input type="checkbox"/> <input type="checkbox"/> | <input type="checkbox"/> <input type="checkbox"/> <input type="checkbox"/> <input type="checkbox"/> |

| END USE CATEGORIES                                | NATURAL GAS              |                          |                          |                          | ELECTRIC                 | OIL OR KEROSENE          | COAL (charcoal)          | PROPANE/ BOTTLED GAS     | OTHER SOURCE             | NONE                     |
|---|--------------------------|--------------------------|--------------------------|--------------------------|--------------------------|--------------------------|--------------------------|--------------------------|--------------------------|--------------------------|
|   | Connected                | Not Connected            | Stub/ Drop               | Red Tag                  |                          |                          |                          |                          |                          |                          |
| <input type="checkbox"/> Central Heating          | <input type="checkbox"/> | <input type="checkbox"/> | <input type="checkbox"/> | <input type="checkbox"/> | <input type="checkbox"/> | <input type="checkbox"/> | <input type="checkbox"/> | <input type="checkbox"/> | <input type="checkbox"/> | <input type="checkbox"/> |
| <input type="checkbox"/> Water Heating            | <input type="checkbox"/> | <input type="checkbox"/> | <input type="checkbox"/> | <input type="checkbox"/> | <input type="checkbox"/> | <input type="checkbox"/> | <input type="checkbox"/> | <input type="checkbox"/> | <input type="checkbox"/> | <input type="checkbox"/> |
| <input type="checkbox"/> Range                    | <input type="checkbox"/> | <input type="checkbox"/> | <input type="checkbox"/> | <input type="checkbox"/> | <input type="checkbox"/> | <input type="checkbox"/> | <input type="checkbox"/> | <input type="checkbox"/> | <input type="checkbox"/> | <input type="checkbox"/> |
| <input type="checkbox"/> Clothes Drying           | <input type="checkbox"/> | <input type="checkbox"/> | <input type="checkbox"/> | <input type="checkbox"/> | <input type="checkbox"/> | <input type="checkbox"/> | <input type="checkbox"/> | <input type="checkbox"/> | <input type="checkbox"/> | <input type="checkbox"/> |
| <input type="checkbox"/> Alternate Heating        | <input type="checkbox"/> | <input type="checkbox"/> | <input type="checkbox"/> | <input type="checkbox"/> | <input type="checkbox"/> | <input type="checkbox"/> | <input type="checkbox"/> | <input type="checkbox"/> | <input type="checkbox"/> | <input type="checkbox"/> |
| <input type="checkbox"/> Source #1                | <input type="checkbox"/> | <input type="checkbox"/> | <input type="checkbox"/> | <input type="checkbox"/> | <input type="checkbox"/> | <input type="checkbox"/> | <input type="checkbox"/> | <input type="checkbox"/> | <input type="checkbox"/> | <input type="checkbox"/> |
| <input type="checkbox"/> Alternate Heating        | <input type="checkbox"/> | <input type="checkbox"/> | <input type="checkbox"/> | <input type="checkbox"/> | <input type="checkbox"/> | <input type="checkbox"/> | <input type="checkbox"/> | <input type="checkbox"/> | <input type="checkbox"/> | <input type="checkbox"/> |
| <input type="checkbox"/> Source #2                | <input type="checkbox"/> | <input type="checkbox"/> | <input type="checkbox"/> | <input type="checkbox"/> | <input type="checkbox"/> | <input type="checkbox"/> | <input type="checkbox"/> | <input type="checkbox"/> | <input type="checkbox"/> | <input type="checkbox"/> |
| <input type="checkbox"/> Combo Space/             | <input type="checkbox"/> | <input type="checkbox"/> | <input type="checkbox"/> | <input type="checkbox"/> | <input type="checkbox"/> | <input type="checkbox"/> | <input type="checkbox"/> | <input type="checkbox"/> | <input type="checkbox"/> | <input type="checkbox"/> |
| <input type="checkbox"/> Water Heater             | <input type="checkbox"/> | <input type="checkbox"/> | <input type="checkbox"/> | <input type="checkbox"/> | <input type="checkbox"/> | <input type="checkbox"/> | <input type="checkbox"/> | <input type="checkbox"/> | <input type="checkbox"/> | <input type="checkbox"/> |
| <input type="checkbox"/> Room Heater              | <input type="checkbox"/> | <input type="checkbox"/> | <input type="checkbox"/> | <input type="checkbox"/> | <input type="checkbox"/> | <input type="checkbox"/> | <input type="checkbox"/> | <input type="checkbox"/> | <input type="checkbox"/> | <input type="checkbox"/> |
| <input type="checkbox"/> Heat Pump                | <input type="checkbox"/> | <input type="checkbox"/> | <input type="checkbox"/> | <input type="checkbox"/> | <input type="checkbox"/> | <input type="checkbox"/> | <input type="checkbox"/> | <input type="checkbox"/> | <input type="checkbox"/> | <input type="checkbox"/> |
| <input type="checkbox"/> Central Air              | <input type="checkbox"/> | <input type="checkbox"/> | <input type="checkbox"/> | <input type="checkbox"/> | <input type="checkbox"/> | <input type="checkbox"/> | <input type="checkbox"/> | <input type="checkbox"/> | <input type="checkbox"/> | <input type="checkbox"/> |
| <input type="checkbox"/> Conditioning             | <input type="checkbox"/> | <input type="checkbox"/> | <input type="checkbox"/> | <input type="checkbox"/> | <input type="checkbox"/> | <input type="checkbox"/> | <input type="checkbox"/> | <input type="checkbox"/> | <input type="checkbox"/> | <input type="checkbox"/> |
| <input type="checkbox"/> Outdoor Grill            | <input type="checkbox"/> | <input type="checkbox"/> | <input type="checkbox"/> | <input type="checkbox"/> | <input type="checkbox"/> | <input type="checkbox"/> | <input type="checkbox"/> | <input type="checkbox"/> | <input type="checkbox"/> | <input type="checkbox"/> |
| <input type="checkbox"/> Outdoor Post Light       | <input type="checkbox"/> | <input type="checkbox"/> | <input type="checkbox"/> | <input type="checkbox"/> | <input type="checkbox"/> | <input type="checkbox"/> | <input type="checkbox"/> | <input type="checkbox"/> | <input type="checkbox"/> | <input type="checkbox"/> |
| <input type="checkbox"/> Patio/Deck               | <input type="checkbox"/> | <input type="checkbox"/> | <input type="checkbox"/> | <input type="checkbox"/> | <input type="checkbox"/> | <input type="checkbox"/> | <input type="checkbox"/> | <input type="checkbox"/> | <input type="checkbox"/> | <input type="checkbox"/> |
| <input type="checkbox"/> Swimming Pool            | <input type="checkbox"/> | <input type="checkbox"/> | <input type="checkbox"/> | <input type="checkbox"/> | <input type="checkbox"/> | <input type="checkbox"/> | <input type="checkbox"/> | <input type="checkbox"/> | <input type="checkbox"/> | <input type="checkbox"/> |
| <input type="checkbox"/> Hot Tub/Spa              | <input type="checkbox"/> | <input type="checkbox"/> | <input type="checkbox"/> | <input type="checkbox"/> | <input type="checkbox"/> | <input type="checkbox"/> | <input type="checkbox"/> | <input type="checkbox"/> | <input type="checkbox"/> | <input type="checkbox"/> |
| <input type="checkbox"/> Fireplace,               | <input type="checkbox"/> | <input type="checkbox"/> | <input type="checkbox"/> | <input type="checkbox"/> | <input type="checkbox"/> | <input type="checkbox"/> | <input type="checkbox"/> | <input type="checkbox"/> | <input type="checkbox"/> | <input type="checkbox"/> |
| <input type="checkbox"/> - gas lighter/starter    | <input type="checkbox"/> | <input type="checkbox"/> | <input type="checkbox"/> | <input type="checkbox"/> | <input type="checkbox"/> | <input type="checkbox"/> | <input type="checkbox"/> | <input type="checkbox"/> | <input type="checkbox"/> | <input type="checkbox"/> |
| <input type="checkbox"/> - gas logs               | <input type="checkbox"/> | <input type="checkbox"/> | <input type="checkbox"/> | <input type="checkbox"/> | <input type="checkbox"/> | <input type="checkbox"/> | <input type="checkbox"/> | <input type="checkbox"/> | <input type="checkbox"/> | <input type="checkbox"/> |
| <input type="checkbox"/> Cooktop                  | <input type="checkbox"/> | <input type="checkbox"/> | <input type="checkbox"/> | <input type="checkbox"/> | <input type="checkbox"/> | <input type="checkbox"/> | <input type="checkbox"/> | <input type="checkbox"/> | <input type="checkbox"/> | <input type="checkbox"/> |
| <input type="checkbox"/> Wall Oven                | <input type="checkbox"/> | <input type="checkbox"/> | <input type="checkbox"/> | <input type="checkbox"/> | <input type="checkbox"/> | <input type="checkbox"/> | <input type="checkbox"/> | <input type="checkbox"/> | <input type="checkbox"/> | <input type="checkbox"/> |
| <input type="checkbox"/> Garage Heater            | <input type="checkbox"/> | <input type="checkbox"/> | <input type="checkbox"/> | <input type="checkbox"/> | <input type="checkbox"/> | <input type="checkbox"/> | <input type="checkbox"/> | <input type="checkbox"/> | <input type="checkbox"/> | <input type="checkbox"/> |
| <input type="checkbox"/> Other (not listed above) | <input type="checkbox"/> | <input type="checkbox"/> | <input type="checkbox"/> | <input type="checkbox"/> | <input type="checkbox"/> | <input type="checkbox"/> | <input type="checkbox"/> | <input type="checkbox"/> | <input type="checkbox"/> | <input type="checkbox"/> |

**NOTE:** If the customer owns a patio/deck, swimming pool, hot tub/spa, or fireplace please fill in the circle under the "Exists" heading.

Form C2997
Printed in U.S.A. Mark Reflex® by NCS MM94380:321 AB407



Distribution Operations

|                               |  |  |
|-------------------------------|--|--|
| Effective Date:<br>01/01/2013 | <b>Inspection and Testing of New,<br/>Repaired or Replaced Customer<br/>Owned House Piping</b> | Standard Number:<br><b>GS 6500.040(KY)</b> |
| Supersedes:<br>02/13/1992     |  | Page 1 of 1                                |

Companies Affected:

|                                 |   |                              |
|---------------------------------|---|------------------------------|
| <input type="checkbox"/> NIPSCO | <input type="checkbox"/> CGV            | <input type="checkbox"/> CMD |
|                                 | <input checked="" type="checkbox"/> CKY | <input type="checkbox"/> COH |
|                                 | <input type="checkbox"/> CMA            | <input type="checkbox"/> CPA |

**REFERENCE ANSI Z223.1 – NFPA54**

**1. GENERAL**

New, Repaired or replaced customer house lines shall be inspected and tested in accordance with the "National Fuel Gas Code" (ANSI Z223.1 - NFPA 54). Minor repairs and additions may be tested in accordance with GS 6500.050 "Methods for Testing Customer Service Lines and/or House Lines".

Gas service shall be established by a representative of the Gas Company only after the piping passes the inspection. If the customer house line does not pass inspection, the customer, owner, plumber or owner's representative shall be notified.

The first Company inspection shall be made without charge. In the event the lines do not pass inspection, the necessary corrections shall be made at the owner's expense and the re-inspection of the lines may be subject to a charge.

**2. RECORDS**

The results of the inspection and test shall be recorded on the DIS Order.

*This document is considered CONTROLLED only when viewed electronically on the Company's intranet. Printed or other electronic copies may not be current, and the intranet version should be used to verify.*



Distribution Operations

Gas Standard

|                               |  |  |
|-------------------------------|--|--|
| Effective Date:<br>02/25/2014 | <b>Methods for Testing Customer Service Lines and/or House Lines</b> | Standard Number:<br><b>GS 6500.050</b> |
| Supersedes:<br>01/01/2013     |  | Page 1 of 5                            |

Companies Affected:

|                                 |   |   |
|---------------------------------|---|---|
| <input type="checkbox"/> NIPSCO | <input checked="" type="checkbox"/> CGV | <input checked="" type="checkbox"/> CMD |
|                                 | <input checked="" type="checkbox"/> CKY | <input type="checkbox"/> COH            |
|                                 | <input checked="" type="checkbox"/> CMA | <input checked="" type="checkbox"/> CPA |

## REFERENCE

### 1. GENERAL

One or a combination of the following test methods shall be used when it is necessary to test customer service lines and/or house lines for leakage when performing various types of service.

### 2. TEST LOW PRESSURE SERVICE LINE AND HOUSE LINES FOR LEAKAGE BY THE PRESSURE DROP METHOD

Low pressure service and house lines may be tested for leakage simultaneously using the pressure drop method as follows.

- a. Close curb valve and open meter valve. Make sure that all appliances are turned off, including pilots.
- b. Attach gauge to an opening in the house line or at an appliance. Do not use an opening downstream of an appliance regulator.
- c. With pressure at "0" observe gauge for rise in pressure. A pressure build-up indicates that the curb valve is leaking through and must be replaced if the leak through cannot be stopped.
- d. Pressurize the piping with air or gas to a pressure at least equal to the operating pressure. Duration of the test shall be not less than three minutes with no drop in pressure. When gas was used as the test medium, at the conclusion of the test, bleed pressure below operating pressure and observe gauge. A pressure build-up indicates the curb valve was not in the fully off position during the test and the test must be repeated.
- e. When leakage is indicated, the service and house lines must be tested separately to determine which is leaking.
- f. A Surface Gas Detection Survey shall be made at the curb box. Any positive indication of gas shall be verified by a combustible gas indicator (CGI) and classified in accordance with the applicable GS 1714.010 "Leakage Classification and Response."
- g. Inside CGI tests shall also be made at floor drains, the gas service entrance when it enters a building below grade, at cracks in the foundation, and other

*This document is considered CONTROLLED only when viewed electronically on the Company's intranet. Printed or other electronic copies may not be current, and the intranet version should be used to verify.*



**Distribution Operations**

**Gas Standard**

|                               |  |  |
|-------------------------------|--|--|
| Effective Date:<br>02/25/2014 | <b>Methods for Testing Customer<br/>Service Lines and/or House Lines</b> | Standard Number:<br><b>GS 6500.050</b> |
| Supersedes:<br>01/01/2013     |  | Page 2 of 5                            |

below grade utility service entrances where applicable. Any positive indication of gas, refer to GS 1708.060 "Inside Leak Investigation."

- h. After the house piping pressure drop test is satisfactorily completed, all appliance connections and internal appliance gas piping which were not exposed to the pressure drop test shall be tested for leakage by a bubble test or leak detector.

### **3. TEST SERVICE LINE FOR LEAKAGE BY THE PRESSURE DROP METHOD**

Service lines may be tested for leakage by the pressure drop method as follows.

- a. Close curb valve, attach gauge as outlined in b. or c. below, bleed lines down to below operating pressure, and watch the gauge for rise in pressure. A build-up indicates that the curb valve is leaking through. The valve is to be replaced if the leak through cannot be stopped.
- b. For low pressure service lines, the gauge should be connected to inlet side of the meter setting, at test tee or at the tapped port on the meter valve. The line is to be pressurized with air or gas to a pressure at least equal to the operating pressure. Duration of the test shall be not less than three minutes with no drop in pressure.
- c. For intermediate, medium, and high pressure services, the gauge should be connected at a test tee or at the tapped port on the meter valve, always on the upstream side of the regulator.
- d. The line shall be pressurized with gas or air to a pressure at least equal to the operating pressure. Duration of the test shall be not less than three minutes with no drop in pressure. When gas was used as the test medium, at the conclusion of the test, bleed pressure below operating pressure and observe gauge. A pressure build-up indicates the curb valve was not in the fully off position during the test and the test must be repeated.
- e. If any of the above tests indicate leakage, use the bubble test on all accessible service fittings, and verify that the meter valve is not leaking through. If a leak is discovered, repairs shall be made by the Company employee at the time of discovery, unless leaks are too extensive and require a plant crew. Leakage on Company owned facilities shall be classified in accordance with the applicable GS 1714.010 "Leakage Classification and Response."
- f. A Surface Gas Detection Survey shall be made at the curb box. Any positive indication of gas shall be verified by a CGI and classified in accordance with the applicable GS 1714.010 "Leakage Classification and Response."
- g. Inside CGI tests shall also be made at floor drains, the gas service entrance when it enters a building below grade, at cracks in the foundation, and other below grade utility service entrances where applicable. Any positive indication of gas, refer to GS 1708.060 "Inside Leak Investigation."



|                               |  |  |
|-------------------------------|--|--|
| Effective Date:<br>02/25/2014 | <b>Methods for Testing Customer Service Lines and/or House Lines</b> | Standard Number:<br><b>GS 6500.050</b> |
| Supersedes:<br>01/01/2013     |  | Page 3 of 5                            |

- h. When leakage is indicated on the service line, the house lines shall also be tested using the meter dial or pressure drop method, so that a complete report can be given to the customer.
- i. The meter, meter setting, service regulator (if present), meter valve and line from meter valve to meter inlet shall be tested for leakage by means of a bubble test or leak detector if they were not included in the pressure test.

**4. TEST SERVICE LINE FOR LEAKAGE BY THE SURFACE GAS DETECTION SURVEY METHOD**

Service lines shall be tested using either the Surface Gas Detection Survey method when gas service was not discontinued by being turned off at the curb valve or the Pressure Drop Method as outlined in Section 3. Refer to GS 1708.030 "Leakage Survey and Test Methods" for further guidance.

All equipment utilized for Surface Gas Detection Surveys shall be set on the proper mode to perform a surface survey and operated in accordance with the manufacturer's instructions.

- a. An outside Surface Gas Detection Survey shall be made over the entire length of the service line with an approved instrument (e.g. multi- purpose CGI, FI, IR) set in the survey mode, outside at the gas service entrance to the building and in the vicinity of the curb box, if one exists. If the location of the service line is unknown, or for additional guidance, refer to the applicable GS 1708.020 "Leakage Surveys" for acceptable leakage survey patterns.
- b. Inside CGI tests shall also be made at floor drains, the gas service entrance when it enters a building below grade, at cracks in the foundation, and other below grade utility service entrances where applicable.

Any indication of gas shall require a more comprehensive leak investigation by performing barholing and testing with a CGI in accordance with the requirements in GS 1708.055 "Performing Barholing." Any leakage found shall be classified in accordance with the applicable GS 1714.010 "Leakage Classification and Response."

**5. TEST HOUSE LINES FOR LEAKAGE BY THE METER DIAL TEST METHOD**

House lines may be tested for leakage using the meter dial test method if the meter is low pressure with a rated capacity of less than 1000 cu. ft./hr. at 1/2" W.C. differential. This test shall be made as follows.

- a. Immediately prior to the test, determine that the meter is in operating condition. This can be done by turning on a small gas burner and observing if there is a movement of the test dial. Also, check to see if the meter has been bypassed. A bubble test shall be made around the meter connections and exposed meter setting fittings. Any leakage discovered at any of these points shall be repaired.





|                               |  |  |
|-------------------------------|--|--|
| Effective Date:<br>02/25/2014 | <b>Methods for Testing Customer Service Lines and/or House Lines</b> | Standard Number:<br><b>GS 6500.050</b> |
| Supersedes:<br>01/01/2013     |  | Page 4 of 5                            |

- b. Make sure that all appliances are turned off including pilots.
- c. Check for leakage by watching the test dial of the meter to determine whether gas is passing through the meter. This observation shall be made with the test hand on the upstroke. To assist in observing any movement of the test hand, mark the dial glass directly over the center line of the hand as soon as the gas is turned on.
- d. Allow 5 minutes for a one-quarter or one-half foot dial, 7 minutes for a one foot dial, 10 minutes for a two foot dial, and 20 minutes for a five foot dial in checking gas flow due to possible leakage.
- e. If observation of the test hand during the specified period of time reveals no movement, no leakage is indicated.
- f. If the meter test hand moves, all appliances or outlets supplied through the system shall be examined to determine that no leak through is occurring.
- g. If leakage is indicated, a reasonable amount of time should be spent to locate leaks using a bubble test on visible fittings and valves. Meter connections and meter setting fittings shall be bubble tested each time they are installed.
- h. Repairs that do not involve replacement of fittings or removal of pipe should be made. Do not make temporary repairs by caulking or other unacceptable methods. Valves may be greased and tightened, but they must still be operable.
- i. When leakage is indicated on the house lines, the service line shall also be tested using the Surface Gas Detection Survey or pressure drop method, so that a full report can be given to the customer.
- j. After the house piping test is satisfactorily completed, all appliance connections and internal appliance gas piping which were not exposed to the meter dial test shall be tested for leakage by a bubble test or leak detector test.
- k. If an appliance is moved, to perform a test or during a test, the appliance connection shall be tested, with a bubble test or leak detector, after the appliance has been put back into place and gas has been restored, but prior to lighting the appliance.

## **6. TEST HOUSE LINES FOR LEAKAGE BY THE PRESSURE DROP METHOD**

House lines may be tested for leakage using the pressure drop method as follows.

- a. Make sure that all appliances are turned off, including pilots.
- b. If the meter is in place, the gauge may be connected to any opening in the house lines that is not downstream of an appliance regulator. On low pressure meter settings, the meter valve is to be closed during the test and house line pressure dropped to below operating pressure. Test meter valve for leak through by observing gauge for build-up in pressure. For MP/HP meter settings, or if the





|                               |  |  |
|-------------------------------|--|--|
| Effective Date:<br>02/25/2014 | <b>Methods for Testing Customer<br/>Service Lines and/or House Lines</b> | Standard Number:<br><b>GS 6500.050</b> |
| Supersedes:<br>01/01/2013     |  | Page 5 of 5                            |

meter is disconnected, the gauge will be connected to the outlet side of the meter setting.

- c. Pressurize the house piping with air or gas to a pressure at least equal to the operating pressure. Duration of test shall be not less than three minutes with no drop in pressure. Gas may only be used as a test medium on MP/HP meter settings if the service regulator(s) can be isolated from the test by a valve downstream of the service regulator(s). The valve must be tested for leak through by observing gauge for build-up in pressure.
- d. If a pressure drop occurs, bubble test around the meter connections and exposed meter setting fittings. Any leakage discovered at any of these shall be repaired. Retest after corrections; if leakage is still present, a reasonable amount of time should be spent to locate leaks, using a bubble test on all visible fittings and valves. Meter connections and meter setting fittings shall be bubble tested each time they are reinstalled.
- e. Repairs that do not involve replacement of fittings or removal of pipe should be made. Do not make temporary repairs by caulking or other unacceptable methods. Valves may be greased or tightened, but they must still be operable.
- f. When leakage is indicated on the house lines, the service line shall also be tested using the Surface Gas Detection Survey or pressure drop method so that a full report can be given to the customer.
- g. The meter, meter setting, service regulator (if present), meter valve and line from meter valve to meter inlet shall be tested for leakage by means of a bubble test or leak detector if they were not included in the pressure test.
- h. After the house piping pressure drop test is satisfactorily completed, all appliance connections and internal appliance gas piping which were not exposed to the pressure drop test shall be tested for leakage by a bubble test or leak detector.
- i. If an appliance is moved, to perform a test or during a test, the appliance connection shall be tested, with a bubble test or leak detector, after the appliance has been put back into place and gas has been restored, but prior to lighting the appliance.



**Distribution Operations**

**Gas Standard**

|                               |                       |  |
|-------------------------------|-----------------------|--|
| Effective Date:<br>10/27/2014 | <b>Turning on Gas</b> | Standard Number:<br><b>GS 6500.060</b> |
| Supersedes:<br>05/01/2014     |                       | Page 1 of 4                            |

Companies Affected:

|                                 |   |   |
|---------------------------------|---|---|
| <input type="checkbox"/> NIPSCO | <input checked="" type="checkbox"/> CGV | <input checked="" type="checkbox"/> CMD |
|                                 | <input checked="" type="checkbox"/> CKY | <input checked="" type="checkbox"/> COH |
|                                 | <input checked="" type="checkbox"/> CMA | <input checked="" type="checkbox"/> CPA |

**REFERENCE**      ANSI Z223.1, NFPA 54

**1. GENERAL**

This procedure shall be followed when turning on gas where gas has been turned off at meter and/or curb valve.

EXCEPTION: Where gas has been turned off after the shut – off of a main, gas shall be turned on in accordance with the applicable GS 6500.130 “Reestablish Service After the Shut – Off of a Main.”

**2. VERIFY JOB ORDER**

The customer service employee, upon arriving at the customer premise, shall review the job order and verify the following.

- a. Customer's name and address.
- b. Existing meter number, kind/size and current meter reading.

**3. PREVENTING ELECTRICAL SHOCK**

Personnel working at a customer’s premise need to be aware of potential electrical shock hazards. To reduce the risk of an electrical shock, employees shall make contact with the gas piping on both the inlet and outlet side of the meter set assembly with a volt meter, or at a minimum, with a non-contact voltage detector prior to any contact with the meter set assembly.

If voltage is detected, follow the remediation requirements of GS 6500.100 “Residential and Small Commercial Meter Requirements,” Section 6.

**4. VISUAL INSPECTION OF EXPOSED HOUSE LINES, APPLIANCES AND METER PRIOR TO TURNING ON GAS**

Arrangements must be made with the customer for access to all rooms in the building where gas outlets and operating controls may exist. The object is to determine that any disconnected gas outlets, including shut off valves, are properly capped or plugged.

*This document is considered CONTROLLED only when viewed electronically on the Company's intranet. Printed or other electronic copies may not be current, and the intranet version should be used to verify.*



|                               |                       |  |
|-------------------------------|-----------------------|--|
| Effective Date:<br>10/27/2014 | <b>Turning on Gas</b> | Standard Number:<br><b>GS 6500.060</b> |
| Supersedes:<br>05/01/2014     |                       | Page 2 of 4                            |

At least one gas appliance should be connected and properly installed, or at a minimum, one appliance branch connection shall be installed with a manual appliance shut-off valve that is plugged or capped before gas can be turned on.

Connected gas appliances shall be visually inspected to determine if the gas piping is installed correctly and, for any vented equipment, the vents shall be checked for proper installation. Any appliance where the gas piping and/or venting is not properly installed shall be red tagged and noted on the job order in accordance with the applicable GS 6500.010 "Use of Red Tag on Appliances."

Gas service facilities shall be visually inspected to discover any gas theft activities, such as meter tampering, bypassing or unauthorized service restoral. Report obvious or suspected gas theft conditions to your Leader for further guidance.

Check the meter to determine if it is properly sized to handle the connected load of the appliances. Refer to the applicable GS 6500.100 "Residential and Small Commercial Meter Requirements."

If any of the reasons above are a cause to deny service, proceed with Sections 5 and 6 so that a complete report can be given to the customer and then turn gas off in accordance with GS 1742.010 "Discontinuing Gas Service."

#### **5. GAS TURNED OFF AT METER ONLY**

Prior to lighting any appliances, test service lines and house lines in accordance with the applicable GS 6500.050 "Methods for Testing Customer Service Lines and/or House Lines." If no leakage is found, proceed to Section 7 and remaining Sections, as applicable.

#### **6. GAS TURNED OFF AT CURB VALVE**

Prior to lighting any appliances, test customer service and house lines in accordance with the applicable GS 6500.050 "Methods for Testing Customer Service Lines and/or House Lines." When the curb valve is turned off, the customer service line shall be pressure drop tested. If no leakage is found, turn gas on at curb valve and proceed with Section 7. If a curb box exists and cannot be located after a reasonable amount of time, an order shall be issued to locate it. When the curb box location is known and the information is not on the job order, the curb box location information shall be recorded on the job order.

#### **7. CHECK METER SETTING FOR INSULATION**

A visual check shall be made to determine that an insulator between the house lines and service line is installed. When the service line or gas carrying portion of the riser is metallic, the meter insulator shall be electrically tested with an approved instrument. Refer to GS 1430.250 "Verifying Electrical Continuity and Isolation," to ensure that the insulator is



|                               |                       |  |
|-------------------------------|-----------------------|--|
| Effective Date:<br>10/27/2014 | <b>Turning on Gas</b> | Standard Number:<br><b>GS 6500.060</b> |
| Supersedes:<br>05/01/2014     |                       | Page 3 of 4                            |

working properly. If none exists or the existing one is ineffective, a new insulator shall be installed in accordance with GS 1420.530 "Installation of Insulators."

**8. CONNECT METER AND/OR TURN ON GAS AT METER VALVE**

Connect meter and/or slowly turn on gas at meter valve.

Meter, meter setting, service regulator (if present), meter valve and line from meter valve to meter inlet shall be checked for leakage by means of a bubble test or leak detector test, if they were not included in the pressure test.

**9. SERVICE REGULATOR AND/OR RELIEF DEVICES**

Service regulator and/or relief devices and their vents shall be installed in accordance with GS 6500.105 "Service Regulator Requirements Residential and Small Commercial."

**10. PURGE HOUSE LINES**

When air is used as a test medium or there is an indication of air in the house lines, air shall be purged from the house lines after turning gas on at the meter regardless of the appliances being placed into operation by the Company. Reference shall be made to the "National Fuel Gas Code," ANSI Z223.1, Section 8.3 for guidance on purging gas piping systems.

Purging may be performed at connected appliances provided the following safety measures are followed while purging.

- a. Wear appropriate PPE during purging operations (e.g. donning safety glasses, gloves, long sleeves).
- b. Piping shall not be purged into the combustion chamber of an appliance.
- c. Means of controlling purge rate must be utilized (e.g. appliance shut-off valve, range top burner valve.)
- d. Sources of ignition must be eliminated unless precautions are taken to perform this operation in a safe manner by ventilation of the space.
- e. The open end of piping systems being purged shall not be discharged into confined spaces.
- f. Never leave the purge point while purging is in progress.

**11. CHECK AND/OR LIGHT APPLIANCES**

The lighting and checking of appliances shall be in accordance with GS 6500.150 "Lighting Appliances."



**Gas Standard**

|                               |                       |  |
|-------------------------------|-----------------------|--|
| Effective Date:<br>10/27/2014 | <b>Turning on Gas</b> | Standard Number:<br><b>GS 6500.060</b> |
| Supersedes:<br>05/01/2014     |                       | Page 4 of 4                            |

**12. RECORDS**

Record the following information on the job order, as applicable.

- a. Meter reading.
- b. Meter number and kind/size, if incorrect.
- c. Customer's name and/or address corrections.
- d. Conditions found which could prove hazardous, such as appliances not turned on, disconnected or red tagged.
- e. Any equipment not checked for safety and reason for not checking.
- f. Whether order was unfinished due to leakage or other required corrections. Provide a concise statement of what needs to be done.
- g. Indicate appliances installed and connected to the house piping system when gas service was established during the completion of this order.
- h. For DIS users, include regulator code on the DIS Order, when applicable. Refer to GS 6500.105 "Service Regulator Requirements Residential and Small Commercial" for further guidance.



**Distribution Operations**

**Gas Standard**

|                               |  |  |
|-------------------------------|--|--|
| Effective Date:<br>01/01/2013 | <b>Establishing Service When Gas<br/>Has Not Been Turned Off</b> | Standard Number:<br><b>GS 6500.090</b> |
| Supersedes:<br>12/27/1993     |  | Page 1 of 1                            |

Companies Affected:

|                                 |   |   |
|---------------------------------|---|---|
| <input type="checkbox"/> NIPSCO | <input checked="" type="checkbox"/> CGV | <input checked="" type="checkbox"/> CMD |
|                                 | <input checked="" type="checkbox"/> CKY | <input checked="" type="checkbox"/> COH |
|                                 | <input type="checkbox"/> CMA            | <input checked="" type="checkbox"/> CPA |

**REFERENCE**    None

**1. GENERAL**

This procedure shall be followed only when service is to be established when gas has not been turned off.

**2. VERIFY DIS ORDER**

The customer service employee, upon arriving at the customer premise, shall review the DIS Order and verify the following:

- a. The customer's name and address.
- b. The existing meter serial number, kind/size code and current meter reading.

**3. RECORD**

Record the following information on the DIS Order, as applicable:

- a. Meter reading.
- b. Meter serial number and kind/size code, if incorrect.
- c. Customer's name and/or address corrections.

NOTE:    Continue to obtain other information, e.g., signature of customer if customer is available, as may be required by other procedures.



**Distribution Operations**

**Gas Standard**

|                               |  |  |
|-------------------------------|--|--|
| Effective Date:<br>10/27/2014 | <b>Residential and Small Commercial Meter Requirements</b> | Standard Number:<br><b>GS 6500.100(KY)</b> |
| Supersedes:<br>05/01/2014     |  | Page 1 of 12                               |

Companies Affected:

|                                 |   |                              |
|---------------------------------|---|------------------------------|
| <input type="checkbox"/> NIPSCO | <input type="checkbox"/> CGV            | <input type="checkbox"/> CMD |
|                                 | <input checked="" type="checkbox"/> CKY | <input type="checkbox"/> COH |
|                                 | <input type="checkbox"/> CMA            | <input type="checkbox"/> CPA |

**REFERENCE** 49 CFR Part 192.353, 192.357, 192.359, 192.465, 192.467, 192.479, 192.725;  
 24 CFR Part 3280; 807 KAR 5:006 Sec. 25 (5)(c)

**1. GENERAL**

The purpose of this standard is to provide requirements during the course of setting and changing residential and small commercial meters.

**2. MANIFOLD METER INSTALLATIONS**

A master meter valve shall be installed on the riser, except as noted below. Individual meter valves controlling each meter shall also be installed.

Exception: For an existing manifold of less than six (6) meters served by a Low Pressure system, no master meter valve is required.

If a single service regulator is installed serving multiple meters, a master meter valve shall be installed upstream of the service regulator on the riser in addition to individual meter valves controlling each meter.

If individual service regulators are installed for each meter, the meter valves shall be installed upstream of each service regulator in addition to the master meter valve installed on the riser.

On new or replaced manifold meter settings, each meter shall be identified with a weather proof tag at the meter valve, meter bar, or house piping, as close as practical to the meter, indicating the apartment number or address that it serves. On existing meter manifolds, when gas is turned on to one or more of the meters on the manifold, the meter shall be identified with a weather proof tag at the meter valve, meter bar, or house piping as close as practical to the meter indicating the apartment number or address that it serves.

**3. METERS INSTALLED INSIDE A BUILDING**

Meters installed inside a building must be located in a ventilated space, not less than three (3) feet from any source of ignition or heat which might damage the meter.

Refer to GS 3020.040 "Meter Set Assembly Protection" for meter set assembly protection requirements.

*This document is considered CONTROLLED only when viewed electronically on the Company's intranet. Printed or other electronic copies may not be current, and the intranet version should be used to verify.*



|                               |  |  |
|-------------------------------|--|--|
| Effective Date:<br>10/27/2014 | <b>Residential and Small Commercial Meter Requirements</b> | Standard Number:<br><b>GS 6500.100(KY)</b> |
| Supersedes:<br>05/01/2014     |  | Page 2 of 12                               |

**4. VERIFY ORDER**

The Job Order shall be reviewed to verify applicable information.

- a. The customer's name and address.
- b. Meter kind, size code, number and meter reading.

**5. CHECK METER SETTING FOR INSULATION**

A visual check shall be made to ascertain that an insulator between the house lines and service line is installed. When the service line or gas carrying portion of the riser is metallic, the meter insulator shall be electrically tested with an approved instrument (refer to GS 1430.250 "Verifying Electrical Continuity and Isolation") to ensure that the insulator is working properly. If none exists or the existing one is ineffective, a new insulator shall be installed in accordance with GS 1420.530 "Installation of Insulators."

**6. PREVENTING ELECTRICAL SHOCK**

Personnel working at a customer's premise need to be aware of potential electrical shock hazards. To reduce the risk of an electric shock, employees shall make contact with the gas piping on both the inlet and outlet side of the meter set assembly with a volt meter, or at a minimum, with a non-contact voltage detector prior to any contact with the meter set assembly. Refer to HS&E Safety Notice, "Electrical Hazard – Electrical Current on a Meter Setting."

**6.1 If Voltage is Detected**

An order is to be generated for service personnel to check for voltage. A reading shall be taken with a multi-meter or non-contact voltage probe on the service line riser and on the house line side of the meter setting for voltage.

**6.1.1 Voltage on House Lines and Service Line**

If voltage is found on both house lines and service line, the main circuit breaker shall be turned off and the meter setting checked again to determine if the voltage was from the home or the service line.

If voltage is eliminated on both house lines and the service line, an insulator shall be installed or repaired/replaced and the gas left off. The main breaker shall be turned back on and the gas left off. A tag, "Voltage Warning - Electrical Shock Hazard" Form GS 6500.100-1 (see Exhibit A), shall be left at the meter setting before the insulator or on a stake. Another tag shall be given to the customer or left at the premise where it will be easily found if the customer is not present. Document findings on the job order.

If voltage is present after the main electric breaker to the home is turned off,





**Distribution Operations**

**Gas Standard**

|                               |  |  |
|-------------------------------|--|--|
| Effective Date:<br>10/27/2014 | <b>Residential and Small Commercial Meter Requirements</b> | Standard Number:<br><b>GS 6500.100(KY)</b> |
| Supersedes:<br>05/01/2014     |  | Page 3 of 12                               |

notify a Field Operations Leader or Front Line Leader (FOL/FLL) for further instruction.

### **6.1.2 Voltage on House Lines Only**

Turn the gas off upstream of the insulator where no voltage is present - do not blind plate the meter. Advise the customer to contact an electrician to remedy the situation. A tag, "Voltage Warning - Electrical Shock Hazard" Form GS 6500.100-1 (see Exhibit A), shall be left at the meter setting before the insulator or on a stake. Another tag shall be given to the customer or left at the premise where it will be easily found if the customer is not present. Document findings on the job order.

### **6.1.3 Voltage on Service Line Only**

Leave gas service on and notify an FOL/FLL for further instruction. A corrosion technician should be dispatched to perform troubleshooting to determine the source of the voltage. A tag, "Danger - Do Not Touch - Electric Shock Hazard" Form GS 6500.100-2 (see Exhibit B), shall be placed at the meter setting before the insulator or on a stake. Another tag shall be given to the customer or left at the premise where it will be easily found if the customer is not present. Document findings on the job order.

## **7. VISUAL INSPECTION FOR GAS THEFT ACTIVITIES**

When changing the meter, a visual inspection shall be conducted to discover whether any gas theft activities such as meter tampering, bypassing or unauthorized service restoral occurred. If an obvious or suspected condition exists, notify local leadership for guidance.

## **8. CARE AND HANDLING OF GAS METERS**

The length of time a gas meter is carried in a vehicle should be kept to a minimum. All new, repaired and removed meters shall be carried in the vehicle in an upright position, capped, and secured for safety purposes and to prevent damage to the meter. Any meter that has been dropped, severely jarred, or otherwise subjected to potential damage, shall be returned to the meter shop for testing.

## **9. METER CLEARANCE**

The distance between the meter and any obstruction to the sides, rear, top, or bottom should be a minimum of six (6) inches but in no case shall the meter touch the ground. Distance between the meter and any obstruction from the front should be a minimum of 36 inches.

It is preferred not to install a meter set assembly under a deck/porch. However, if no other options are practical, a meter set assembly shall have sufficient access to allow for future maintenance and operation of the meter and operation of the shut-off valve. For such



|                               |  |  |
|-------------------------------|--|--|
| Effective Date:<br>10/27/2014 | <b>Residential and Small Commercial Meter Requirements</b> | Standard Number:<br><b>GS 6500.100(KY)</b> |
| Supersedes:<br>05/01/2014     |  | Page 4 of 12                               |

installations, follow the requirements contained in GS 6500.105 “Service Regulator Requirements” for regulator vent line installation.

## 10. METER ALIGNMENT AND SUPPORT

Each meter set assembly shall be installed in such a manner as to minimize stress on both the piping and the meter and/or service regulator. A meter set assembly shall be supported by at least one of the following methods.

- a. Wall bracket (see Exhibit C).
- b. Support stakes (see Exhibit D).
- c. Other method approved by leadership.

NOTE: Corrosion control methods should be considered when supporting a meter set assembly. Refer to the 1400 Series of the Gas Standards for further guidance.

## 11. METER SIZING

Gas meters for residential and small commercial applications shall be selected for the maximum expected pressure and permissible pressure drop, which shall not reduce the delivery pressure below the appliance minimum inlet pressure. In no instance shall the pressure drop (pressure differential across the meter), exceed two (2) inches w.c. differential.

### 11.1 Residential Applications

The sizing of residential meters shall be based on the input of central heating and/or space heating equipment and the water heater(s); or gas fired air conditioning equipment, pool heaters, and the water heater(s); whichever combination has the highest aggregate input. If a natural gas fired electric generator is connected to the house piping, it shall also be used with the aforementioned appliances in calculating the total input for the purpose of sizing the meter.

Pool heaters, if present, that have a higher rated input than the central heating and/or space heating equipment are typically used in the calculation in lieu of the central heating and/or space heating equipment, along with the water heater(s) and/or gas fired electric generator. If the pool heater is utilized during periods where the central heat and/or space heating equipment may also be used, or if unsure of its use during periods when the central heat and/or space heating equipment may be used, it too must be added in the load calculation in sizing the meter.

### 11.2 Small Commercial Applications

The sizing of small commercial meters is typically based on the input of all connected appliances. For new meter set assemblies, a diversity factor of 70% may be used if



|                               |  |  |
|-------------------------------|--|--|
| Effective Date:<br>10/27/2014 | <b>Residential and Small Commercial Meter Requirements</b> | Standard Number:<br><b>GS 6500.100(KY)</b> |
| Supersedes:<br>05/01/2014     |  | Page 5 of 12                               |

approved by engineering to size the meter when multiple heating units are connected (e.g., multiple heating units serving warehouse space).

## 12. CHANGING METERS

After turning gas off at the meter valve and changing the meter, test the house and service lines for leakage using one of the methods outlined in the applicable GS 6500.050 "Methods for Testing Customer Owned Service Lines and/or House Lines."

When installing the new meter, new meter gaskets shall be installed and an approved anti-seize lubricant shall be applied to the meter spud threads – care must be exercised to ensure that none of the lubricant can enter the interior of the meter or meter spuds.

The Meter Set Assembly (including the meter and regulator) shall be checked for leakage by means of a bubble test or leak detector test, if not included in one of the test methods outlined in the gas standards referenced in Section 14 below of this standard.

If the meter is changed or tested on location and gas has been bypassed during the change or test, no tests of house and/or service lines are necessary. All fittings that were disturbed and valves that were operated should be bubble tested.

## 13. LIQUIDS IN METERS

Liquids discovered in a meter require it to be changed immediately. The meter shall be carefully removed from its setting and caps installed on both the inlet and outlet to prevent liquid spillage. The meter shall be brought back to a company facility and placed in an appropriate storage location designated for hazardous pipeline liquids. The meter shall be tested for the presence of PCBs. Refer to the applicable GS 4400.050 "Pipeline Liquids Management" for further requirements.

Liquids discovered in meters shall be treated as hazardous and precautionary steps shall be taken to avoid coming in contact with the liquid.

## 14. SETTING NEW METERS

When setting a new meter, house and service lines shall be tested using a method outlined in the following applicable standards:

- a. GS 6500.040 "Inspection and Testing of New, Repaired or Replaced Customer Owned House Piping."
- b. GS 6500.050 "Methods for Testing Customer Service Lines and/or House Lines."

When installing the new meter, new meter gaskets shall be installed and an approved anti-seize lubricant shall be applied to the meter spud threads – care must be exercised to insure that none of the lubricant can enter the interior of the meter or meter spuds. The Meter Set Assembly (including the meter and regulator) shall be checked for leakage by means of a bubble test or leak detector test, if not included in one of the test methods outlined in the



**Distribution Operations**

**Gas Standard**

|                               |  |  |
|-------------------------------|--|--|
| Effective Date:<br>10/27/2014 | <b>Residential and Small Commercial Meter Requirements</b> | Standard Number:<br><b>GS 6500.100(KY)</b> |
| Supersedes:<br>05/01/2014     |  | Page 6 of 12                               |

above referenced standards.

**15. MOBILE HOME/MANUFACTURED HOME METER SET ASSEMBLY – ADDITIONAL REQUIREMENTS**

- a. The meter set assembly (including service regulator if necessary), shall be rigidly supported at the service riser and at the house line outlet on the mobile/manufactured home (manufactured home). See Exhibit E.
- b. The meter set assembly shall be connected to the mobile/manufactured home gas supply connection by a listed gas supply connector for manufactured homes, not less than 3/4 inch I.D. tubing size, with a rated capacity equal to, or greater than the connected Btu/h rating of the connected appliances. The gas supply connection shall not be located beneath an exit door of the manufactured home and the connector end must be located outside of the skirting. See Exhibit C.
- c. The gas pressure serving a manufactured home shall not exceed 14 inches water column.
- d. All manufactured homes utilizing fuel gas for any purpose shall be equipped with a natural gas piping system that is acceptable for LP-gas.

**16. SERVICE REGULATOR REQUIREMENTS**

Self-operated, single-ported service regulators under two (2) inch, serving domestic or large volume meters, shall be tested/inspected at the time of regulator installation, regulator repair, meter change or meter installation. Refer to GS 6500.105 "Service Regulator Requirements Residential and Small Commercial" for guidance.

**17. ESTABLISH/REESTABLISH SERVICE AND LIGHT APPLIANCES**

Refer to the following applicable gas standards GS 6500.050 "Methods for Testing Customer Service Lines and/or House Lines," GS 6500.060 "Turning on Gas," and GS 6500.150 "Lighting Appliances."

**18. RECORDS**

Record the necessary information on the Job Order. The following items shall be recorded:

- a. Meter readings and meter kind and size and meter number(s).
- b. All conditions reported to the customer that must be corrected.
- c. If the order was unfinished due to leakage or other required corrections that the Service Department will follow-up on, take the appropriate job order. If the follow-up work will be completed by the Plant Department, locate curb box, charge curb stop, etc., then check "Further Action Required" and give a concise statement of what actions are needed.



**Distribution Operations**

**Gas Standard**

|                               |  |  |
|-------------------------------|--|--|
| Effective Date:<br>10/27/2014 | <b>Residential and Small Commercial Meter Requirements</b> | Standard Number:<br><b>GS 6500.100(KY)</b> |
| Supersedes:<br>05/01/2014     |  | Page 7 of 12                               |

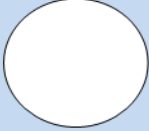
**19. CURB VALVE OPERABILITY**

Curb Valves shall be inspected for operability at the time of the meter change. The inspection shall include removal of the curb box lid, cleaning out as necessary and placement of a curb key on the curb valve.

A Work Management System (WMS) Job Order shall be issued to correct all deficiencies reported regarding curb valve operability. Deficiencies shall be corrected by the end of the third calendar month following reporting. Acceptable methods of correcting deficiencies include repair, replacement or removal of the curb valve.

|                               |  |  |
|-------------------------------|--|--|
| Effective Date:<br>10/27/2014 | <b>Residential and Small Commercial Meter Requirements</b> | Standard Number:<br><b>GS 6500.100(KY)</b> |
| Supersedes:<br>05/01/2014     |  | Page 8 of 12                               |

**EXHIBIT A**

# Warning!

Do Not Touch Gas  
Meter Or Piping

Electrical Shock Hazard!

Date: \_\_\_/\_\_\_/\_\_\_ Time \_\_\_\_\_ AM PM


While inspecting your meter setting we discovered voltage on the gas piping on the customer's side of the meter. To prevent an unsafe situation, we have discontinued gas service to your residence.

Please contact a qualified electrician to make repairs. Once repairs have been completed, please contact Columbia Gas to have your service restored.

If you have questions regarding your service, please call Columbia Gas.

Telephone No. \_\_\_\_\_<sup>1</sup>

Company  
Logo<sup>2</sup>



Form GS 6500.100-1 (04-2014)

<sup>1</sup> Fill in Customer Contact Center phone no. for State form ordered from the Dupli catalog.  
<sup>2</sup> Select the Company Logo from the drop-down box in the Dupli Forms catalog.

|                               |  |  |
|-------------------------------|--|--|
| Effective Date:<br>10/27/2014 | <b>Residential and Small Commercial Meter Requirements</b> | Standard Number:<br><b>GS 6500.100(KY)</b> |
| Supersedes:<br>05/01/2014     |  | Page 9 of 12                               |

**EXHIBIT B**

**Danger !**  
**Do Not Touch**  
**Electrical Shock Hazard !**

Date: \_\_\_/\_\_\_/\_\_\_ Time \_\_\_\_\_ AM   
PM

If you have questions regarding your service,  
please call Columbia Gas.

Telephone No. \_\_\_\_\_ <sup>1</sup>

Company  
Logo<sup>2</sup>

Gas has been turned OFF for safety.

Contact an Electrical Contractor for necessary  
repairs. After repairs have been made, please  
call Columbia Gas to have your service restored.

Gas has been left ON.

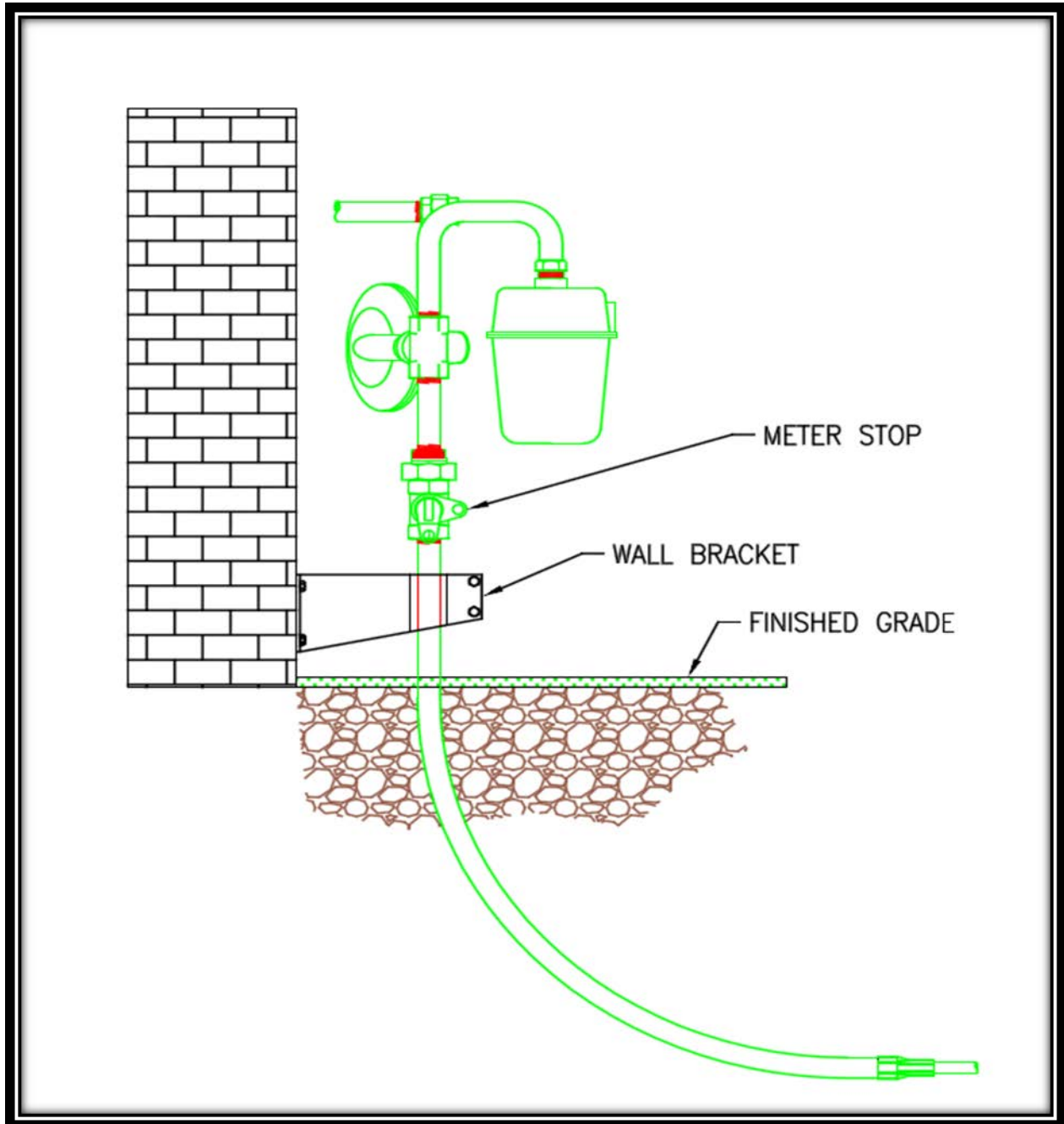
Form GS 6500.100-2 (04-2014)

<sup>1</sup> Fill in Customer Contact Center phone no. for State form ordered from the Dupli catalog.

<sup>2</sup> Select the Company Logo from the drop-down box in the Dupli Forms catalog.

|                               |  |  |
|-------------------------------|--|--|
| Effective Date:<br>10/27/2014 | <b>Residential and Small Commercial Meter Requirements</b> | Standard Number:<br><b>GS 6500.100(KY)</b> |
| Supersedes:<br>05/01/2014     |  | Page 10 of 12                              |

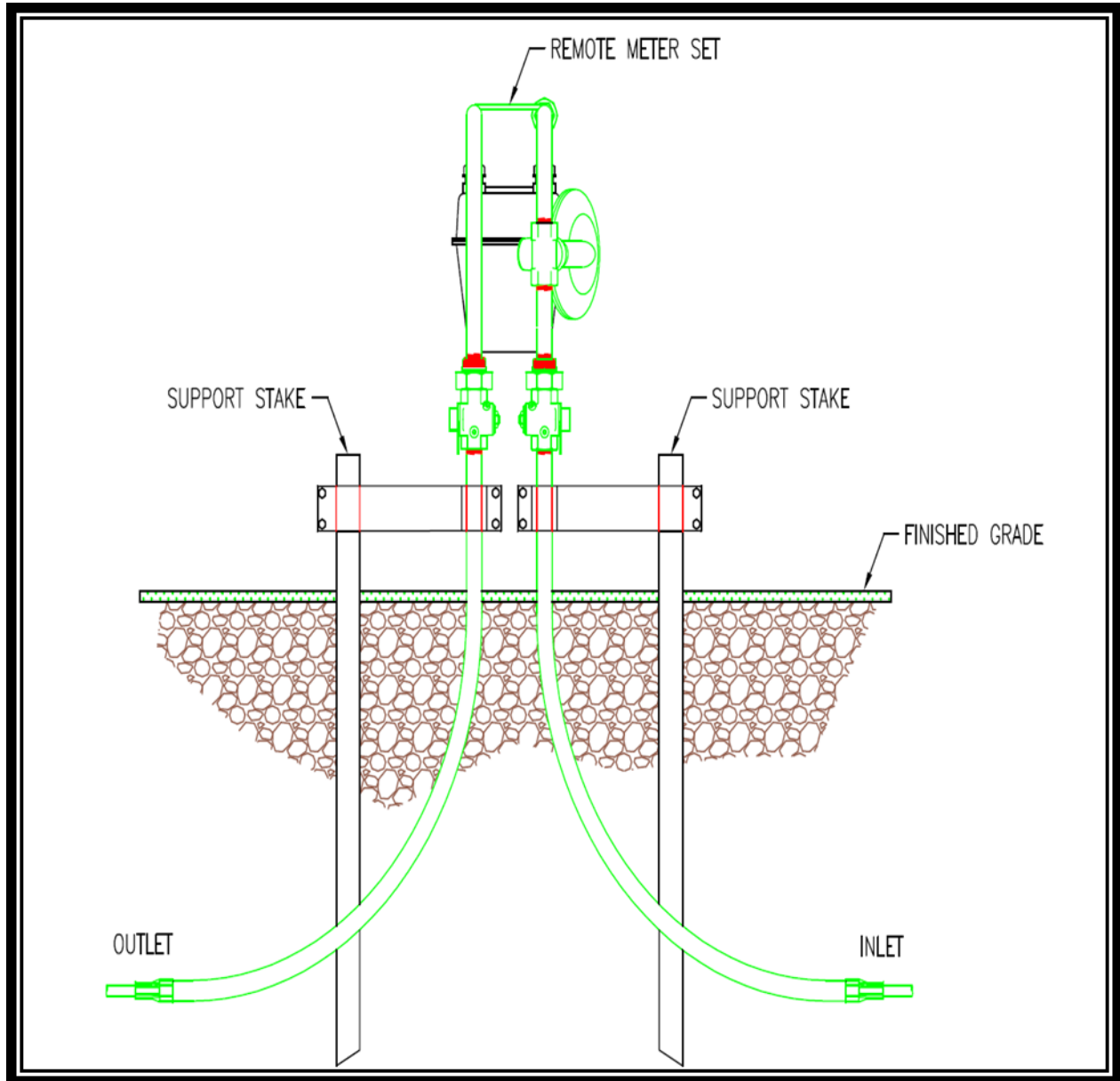
**EXHIBIT C**





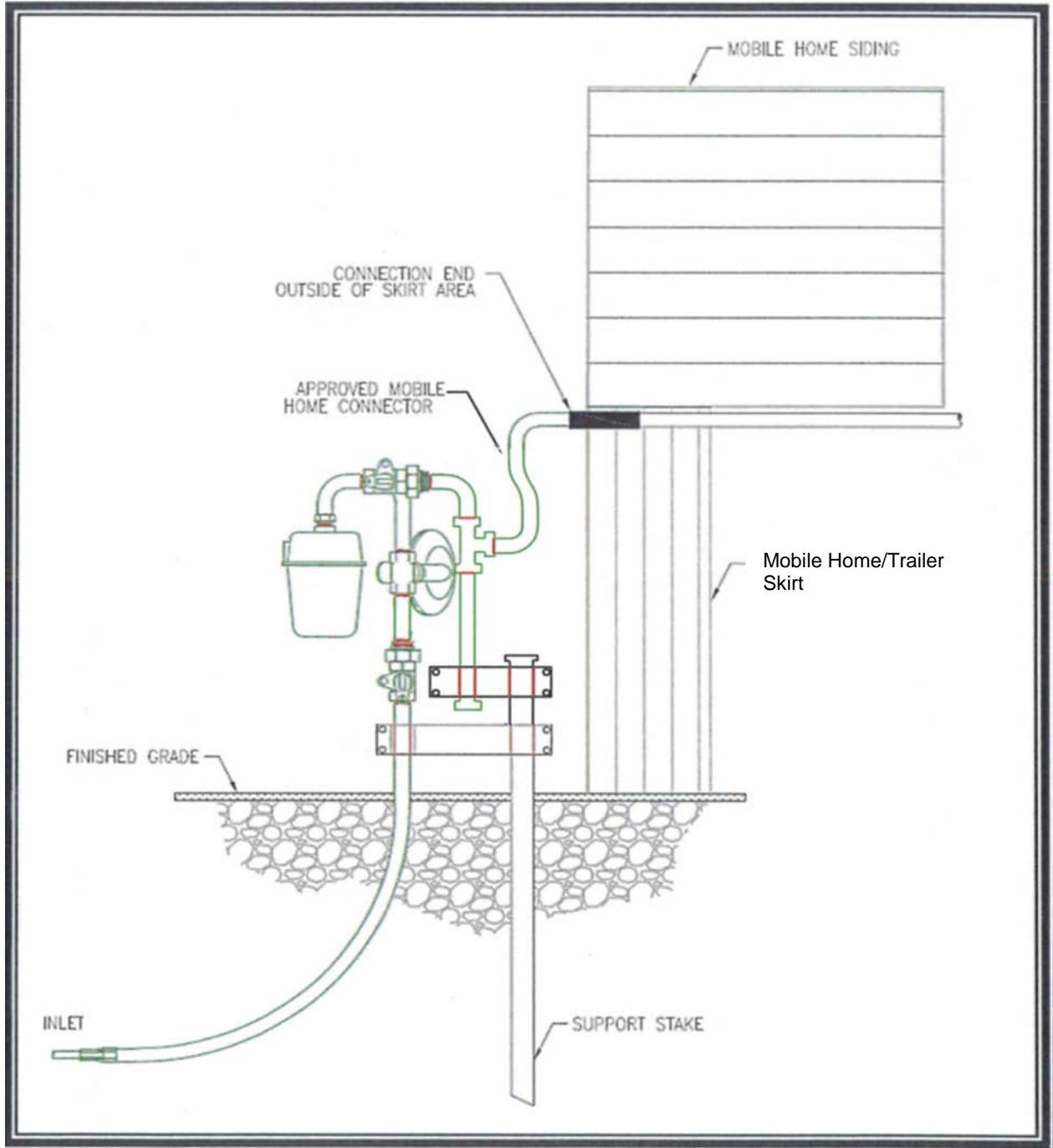
|                               |  |  |
|-------------------------------|--|--|
| Effective Date:<br>10/27/2014 | <b>Residential and Small Commercial Meter Requirements</b> | Standard Number:<br><b>GS 6500.100(KY)</b> |
| Supersedes:<br>05/01/2014     |  | Page 11 of 12                              |

**EXHIBIT D**



|                               |  |  |
|-------------------------------|--|--|
| Effective Date:<br>10/27/2014 | <b>Residential and Small Commercial Meter Requirements</b> | Standard Number:<br><b>GS 6500.100(KY)</b> |
| Supersedes:<br>05/01/2014     |  | Page 12 of 12                              |

**EXHIBIT E**





**Distribution Operations**

**Gas Standard**

|                               |  |  |
|-------------------------------|--|--|
| Effective Date:<br>05/01/2014 | <b>Service Regulator Requirements<br/>Residential and Small Commercial</b> | Standard Number:<br><b>GS 6500.105</b> |
| Supersedes:<br>N/A            |  | Page 1 of 8                            |

Companies Affected:

|                                 |   |   |
|---------------------------------|---|---|
| <input type="checkbox"/> NIPSCO | <input checked="" type="checkbox"/> CGV | <input checked="" type="checkbox"/> CMD |
|                                 | <input checked="" type="checkbox"/> CKY | <input checked="" type="checkbox"/> COH |
|                                 | <input checked="" type="checkbox"/> CMA | <input checked="" type="checkbox"/> CPA |

**REFERENCE** 49 CFR Part 192.353, 192.355, 192.357

**1. GENERAL**

The purpose of this standard is to provide requirements for the inspection or installation of residential and small commercial regulators installed on piping systems with operating pressures greater than low pressure (>LP) to a maximum allowable operating pressure (MAOP) of 125 psig. When regulators are installed on piping systems with an MAOP exceeding 60 psig, reference shall be made to GS 6400.420 "High Pressure Service Regulator and Meter Setting Selection" for additional requirements. All service regulators showing external corrosion or damage shall be replaced.

All service regulators serving residential and small commercial meters without over pressure protection, full internal relief or associated external relief devices should be changed upon discovery. At a minimum, the Integration Center shall be notified and a service order created to change the regulator as soon as practical.

Service regulators are to be located where gas from the vent can escape freely into the atmosphere and away from any opening(s) into a building.

**NOTE:** Mercury regulators and/or external mercury relief devices encountered in the field shall be removed as soon as practical. Upon discovery and prior to removal of a mercury regulator and/or external mercury relief device, a member of the Operations Center leadership team and a member of the Health Safety and Environmental (HSE) team shall be notified. Inspect the area beneath the regulator and/or relief device for evidence of a previous mercury spill and take precautions to ensure that any mercury is not disturbed or tracked through the building. Never attempt to remove a mercury regulator and/or external mercury relief device without assistance and guidance from a member of the Operations Center Leadership team and a member of the HSE team. In addition to the above requirements, prior to disturbing or removing a suspected mercury regulator and/or external mercury relief device, reference shall be made to the applicable GS 4100.060 "Handling, Storing, Transporting and Disposal of Mercury."

**2. SERVICE REGULATOR REQUIREMENTS**

The Company's standard billing and delivery pressure is 7 inches water column (7" w.c.).

*This document is considered CONTROLLED only when viewed electronically on the Company's intranet. Printed or other electronic copies may not be current, and the intranet version should be used to verify.*



|                               |  |  |
|-------------------------------|--|--|
| Effective Date:<br>05/01/2014 | <b>Service Regulator Requirements<br/>Residential and Small Commercial</b> | Standard Number:<br><b>GS 6500.105</b> |
| Supersedes:<br>N/A            |  | Page 2 of 8                            |

For new installations, if a higher set pressure is necessary to adequately serve the customer, this condition shall be reported to the New Business Team, who may decide to provide Fixed Pressure Factor Metering (FPFM). Refer to GS 6400.090 "Fixed Pressure Factor Metering" for additional requirements.

If an immediate need for a higher delivery pressure is discovered (to prevent delayed ignition or other adverse appliance operating conditions), a Field Operations Leader or Front Line Leader shall be contacted for direction. Refer to GS 6400.090 "Fixed Pressure Factor Metering" for additional requirements.

Consideration should be given as to the location of the service regulator and/or relief device to avoid sources of ignition and the possibility of vent terminal freeze-ups. Regulator vent skirts or a vent line extending the vent terminal away from the potential source of moisture should be considered if the potential for vent terminal blockage due to freeze-up is evident.

## **2.1 Service Regulator Vent Requirements**

The regulator and/or relief device vent; vent line, if so equipped; screen; and cap, if present; shall be properly sized, installed, and free of blockage, restrictions or valves, with no external leakage.

### **2.1.1 Aboveground Vent Lines**

When a regulator and/or relief device is located inside a building, each regulator and/or relief device shall have a separate metallic relief vent line vented to the outdoors so in the event gas is discharged, it will not create a hazard. Under no circumstance shall the relief vent lines of separate regulators and/or relief devices be manifolded.

If tubing is used for the relief vent line, it shall be metallic and one size larger than the relief opening. In no case shall corrugated tubing be used as a regulator relief vent line.

Relief vent lines shall be as short as possible, and when in excess of ten (10) feet in length or contain more than two (2) elbows, shall be increased one nominal pipe size for each additional ten (10) feet of length. Each elbow in the vent line will contribute approximately three (3) feet in effective length, including the termination elbow.

Service regulators installed outdoors of a building requiring a relief vent line, may be equipped with a PVC vent line conforming to UL 651, schedule 40 or schedule 80 rigid PVC conduit. Under no circumstance shall the relief vent line be combined with another regulator relief vent line. The same sizing guidance provided above applies.

|                               |  |  |
|-------------------------------|--|--|
| Effective Date:<br>05/01/2014 | <b>Service Regulator Requirements<br/>Residential and Small Commercial</b> | Standard Number:<br><b>GS 6500.105</b> |
| Supersedes:<br>N/A            |  | Page 3 of 8                            |

### 2.1.2 Belowground Vent Lines

That portion of the regulator vent line that is exposed shall be installed in accordance with the requirements set forth in Section 2.1.1 of this standard. Under no circumstance shall the relief vent lines of separate regulators and/or relief devices be manifolded.

When no other alternatives exist and it becomes necessary to install a portion of the regulator vent line underground, that portion of the belowground vent line shall be constructed of:

- a. Steel pipe in accordance with the requirements in the 3020 Series of the Gas Standards and protected against corrosion in reference to the 1400 series of the Gas Standards, or
- b. Polyethylene pipe installed in accordance with the 3020 Series of the Gas Standards.

Relief vent lines shall be as short as possible, and when in excess of ten (10) feet in length or contain more than two (2) elbows (including the termination elbow), shall be increased one nominal pipe size for each additional ten (10) feet of length. Each elbow in the vent line will contribute approximately three (3) feet in effective length. All elbows and fittings shall be welded by a qualified welder in accordance with the applicable Company Welding Manual.

### 2.1.3 Service Regulator Vent Terminal Requirements

**NOTE:** All measurements shall be taken from the service regulator vent terminal (relief opening) (see Exhibits A and B).

Except as noted below, the vent terminal:

- a. Shall be installed outdoors above grade, at a minimum height of 12 inches above grade.
- b. In areas where flooding may occur, a minimum height in excess of 12 inches may be required to prevent the entry of water into the vent terminal.
- c. Shall be installed to protect it from the entry of insects by a screen or an approved vent cap, and be installed so as to prevent the entry of rainwater.
- d. Shall be located not less than three (3) feet radially and not directly below any rotating electrical equipment (e.g., an air conditioning unit).
- e. Should be installed with a minimum of three (3) feet radial separation from an electric meter, electric panel, electric outlet,



|                               |  |  |
|-------------------------------|--|--|
| Effective Date:<br>05/01/2014 | <b>Service Regulator Requirements<br/>Residential and Small Commercial</b> | Standard Number:<br><b>GS 6500.105</b> |
| Supersedes:<br>N/A            |  | Page 4 of 8                            |

electric pedestal, electrical equipment disconnect, or pad mounted transformer, etc. When it is not possible to install the regulator vent terminal with a three (3) foot radial separation, a minimum of one (1) foot radial separation shall be maintained between the regulator vent terminal and any of the electric equipment listed above.

- f. Shall be located three (3) feet radially from, and not below, any first floor opening into a building, such as a door, window(s) (that can be opened) or other gravity air opening(s) into a building (including clothes dryer exhaust terminals, and appliance air intakes).
- g. Shall be located not less than ten (10) feet radially from, and not below any forced air inlet into a building (excluding appliance air intakes).

**NOTE:** It may be acceptable for reduced clearances from building openings and potential sources of ignition when approved self-operated diaphragm service regulators equipped with over pressure protection and vent limiting devices are installed.

**2.2 Testing and Inspection Requirements**

Self-operated, single-ported service regulators under two (2) inches, serving domestic or large volume meters, shall be tested/inspected at the time of regulator installation, regulator repair, meter change or meter installation.

When performing any of the tests required in this standard, the inlet meter setting valve shall be opened slowly to prevent the relief from opening or damage to the regulator diaphragm.

**2.2.1 Set Pressure and Lock-Up Pressure Tests**

The standard orifice size is 3/16 inch for service regulators installed on piping systems with an operating pressure greater than LP to 60 psig MAOP.

For systems with an MAOP above 60 psig to 125 psig and a minimum operating pressure of 10 psig, the orifice size shall be reduced to 1/8 inch. Refer to GS 6400.420 “High Pressure Service Regulator and Meter Setting Selection.”

If the minimum operating pressure of a system with an MAOP of 60 psig to 125 psig falls below 10 psig, a high pressure service regulator shall be installed along with a final-cut service regulator with a 3/16 inch orifice in accordance with the requirements found in GS 6400.420 “High Pressure Service Regulator and Meter Setting Selection.”

For regulators installed on any piping systems with an MAOP greater than 60 psig, reference shall be made to GS 6400.420(CG) “High Pressure Service



**Distribution Operations**

**Gas Standard**

|                               |  |  |
|-------------------------------|--|--|
| Effective Date:<br>05/01/2014 | <b>Service Regulator Requirements<br/>Residential and Small Commercial</b> | Standard Number:<br><b>GS 6500.105</b> |
| Supersedes:<br>N/A            |  | Page 5 of 8                            |

Regulator and Meter Setting Selection” for guidance in addition to the requirements set forth in this standard.

Service regulators shall have a set pressure and lock up test performed with the meter removed, unless other means have been provided.

For service regulators to be set at 7” w.c., the set pressure shall be adjusted to a minimum of 7” w.c. and the lock up pressure shall not exceed 12” w.c. If the set pressure is between 7” w.c. and 9” w.c. and the lock up pressure is 12” w.c. or less, no further action is necessary. If the set pressure is between 7” w.c. and 9” w.c. and the lock up pressure exceeds 12” w.c., the regulator must be adjusted, repaired or replaced.

**3. ESTABLISH / REESTABLISH SERVICE**

See the applicable GS 6500.150 “Lighting Appliances When Establishing or Reestablishing Service.”

**4. RECORDS**

Record the necessary information on the Mobile Data Terminal (MDT) order, including pertinent information regarding the service regulator(s) (e.g. for DIS users - Meter Pressure Compensation Codes and Service Regulator Codes).

|  |                                     |
|--|-------------------------------------|
| <b>Meter Pressure Compensation Codes</b> |                                     |
|  | Blank No Pressure Compensation (LP) |
| 1  | Compensated by computer (FPCC)      |
| 2  | Compensated by index (FPCI)         |
| 3  | Compensated by GMB (GMB)            |



**Distribution Operations**

**Gas Standard**

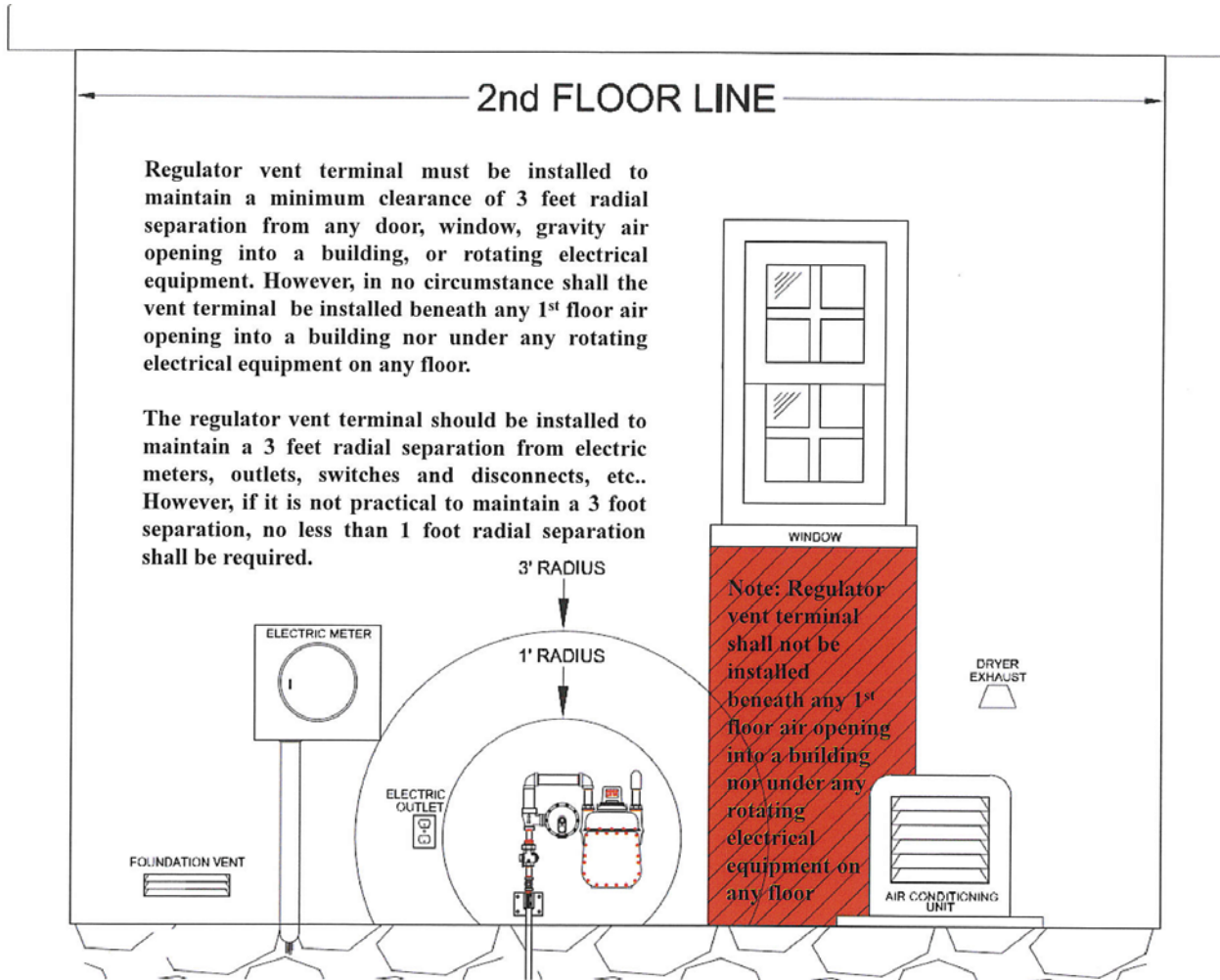
|                               |  |  |
|-------------------------------|--|--|
| Effective Date:<br>05/01/2014 | <b>Service Regulator Requirements<br/>Residential and Small Commercial</b> | Standard Number:<br><b>GS 6500.105</b> |
| Supersedes:<br>N/A            |  | Page 6 of 8                            |

**Service Regulator Codes**  
**Example: F1M79**  
F-Domestic Meter w/ full relief  
1-One regulator  
M-Regulator inspection at meter change.  
79-Year of installation/inspection.  
**First Letter**  
F-Domestic Meter - Regulator w/ full relief  
N-Domestic Meter - Regulator w/o relief  
P-Domestic Meter-Reg. w/ partial relief  
M-Domestic Meter - Reg. w/ internal monitor  
U-Domestic Meter-Unidentified Reg.  
X-Domestic Meter - Multiple regulators  
G-Grouped Dom. Mtrs - Reg. Under 2"  
T-Grouped Dom. Mtrs - Reg. 2" & over  
L-Large Volume Meter-All service reg.  
**First Number - Number of Regulators**  
0-No Regulators  
1-One Regulator  
2-Two Regulators  
3-Three Regulators  
4-Four Regulators  
5,6 and so on # Regulators  
**Third Position - Inspection Interval**  
1-Annual  
2-Two Year  
0-Ten Year  
M-Time of Meter Change  
**Last Two Numbers - Year of Last Inspection**



|                               |  |  |
|-------------------------------|--|--|
| Effective Date:<br>05/01/2014 | <b>Service Regulator Requirements<br/>Residential and Small Commercial</b> | Standard Number:<br><b>GS 6500.105</b> |
| Supersedes:<br>N/A            |  | Page 7 of 8                            |

**EXHIBIT A**



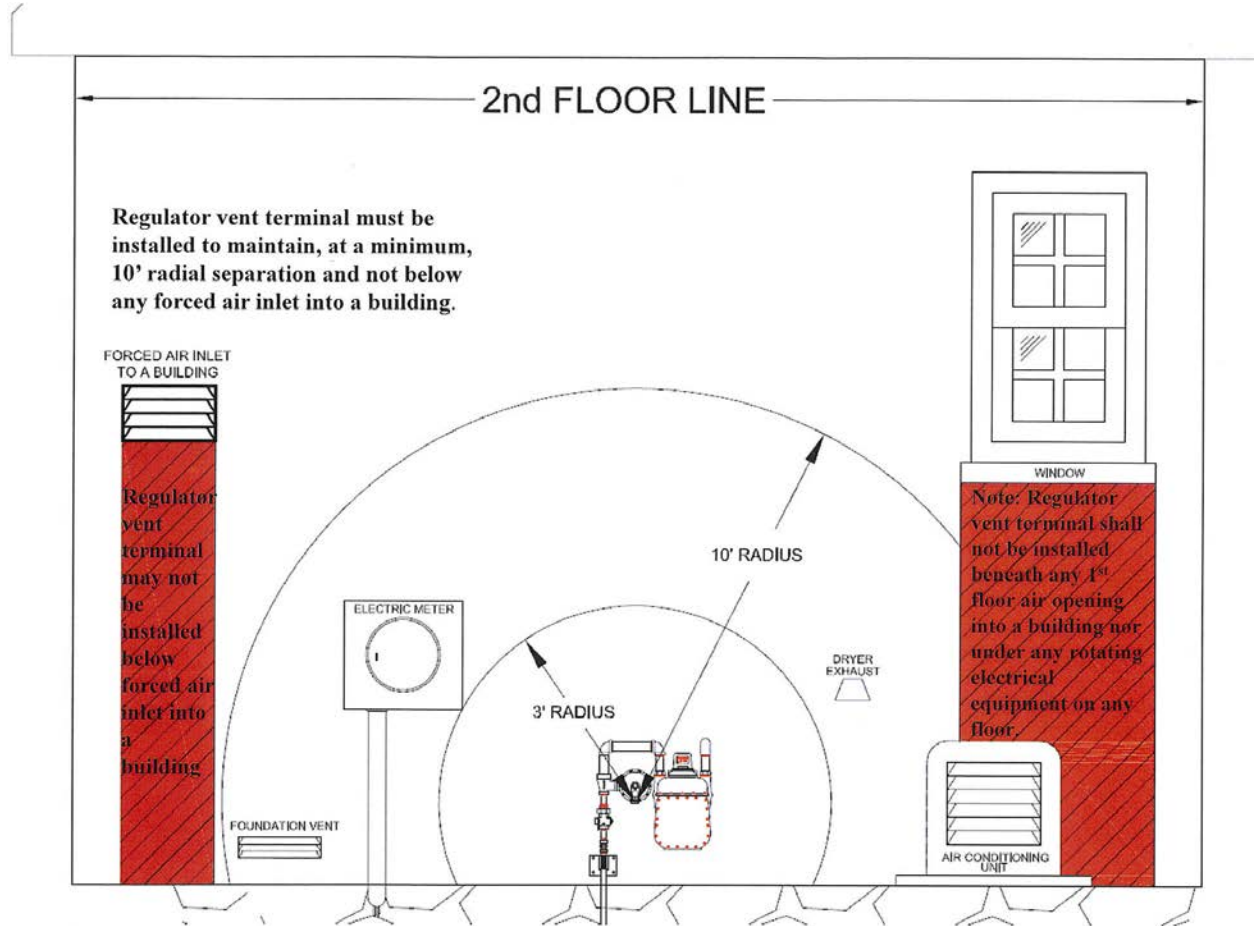


Distribution Operations

Gas Standard

|                               |  |  |
|-------------------------------|--|--|
| Effective Date:<br>05/01/2014 | <b>Service Regulator Requirements<br/>Residential and Small Commercial</b> | Standard Number:<br><b>GS 6500.105</b> |
| Supersedes:<br>N/A            |  | Page 8 of 8                            |

**EXHIBIT B**





**Distribution Operations**

**Gas Standard**

|                               |   |  |
|-------------------------------|---|--|
| Effective Date:<br>01/01/2013 | <b>Reestablish Service After the Shut-Off of a Main</b> | Standard Number:<br><b>GS 6500.130</b> |
| Supersedes:<br>11/15/1984     |   | Page 1 of 2                            |

Companies Affected:

|                                 |   |   |
|---------------------------------|---|---|
| <input type="checkbox"/> NIPSCO | <input checked="" type="checkbox"/> CGV | <input checked="" type="checkbox"/> CMD |
|                                 | <input checked="" type="checkbox"/> CKY | <input type="checkbox"/> COH            |
|                                 | <input checked="" type="checkbox"/> CMA | <input checked="" type="checkbox"/> CPA |

**REFERENCE**    None

**1. NOTIFY CUSTOMER**

When service is interrupted to any of the company's plant facilities that will affect service to customers, the customers involved shall be notified as to the reason and approximate length of time the gas will be off. In the event there is no one home, a tag shall be left stating the reason for the interruption.

**2. TURN OFF GAS**

Gas shall be turned off at either the meter valve or the curb valve.

**3. REESTABLISH SERVICE**

When gas service is to be restored, the gas will be turned on, and a check for open lines or appliance valves shall be made by observing the meter test dial. The appliances shall be restarted by the Company unless they have been restarted by the customer or the customer requests that they not be restarted.

Purge house lines at all connected appliances. Piping shall not be purged into the combustion chamber of an appliance. The open end of piping systems being purged shall not be discharged into confined spaces or areas where there are sources of ignition unless precautions are taken to perform this operation in a safe manner by ventilation of the space, control of the purging rate and the elimination of all hazardous conditions. Never leave the purge point while purging is in progress.

In the event the customer is not at home when the gas service is available, the gas shall be left off with the meter valve locked and the meter sealed, or, if unable to gain access to the meter, the curb valve shall be turned off. A tag will be left advising the customer to call the Gas Company to have service restored. When the customer calls to have the gas turned on, the house and service lines shall be tested using one or a combination of the test methods outlined in GS 6500.050 "Methods for Testing Existing Customers' House and/or Service Lines."

When a customer owned service line has been disconnected, it shall be tested as outlined in GS 6500.070 "Inspection and Testing of Repaired Service Lines" - Section 3.4 "Temporarily Disconnected." When a company owned service line has been disconnected, it shall be

*This document is considered CONTROLLED only when viewed electronically on the Company's intranet. Printed or other electronic copies may not be current, and the intranet version should be used to verify.*



**Distribution Operations**

**Gas Standard**

|                               |   |  |
|-------------------------------|---|--|
| Effective Date:<br>01/01/2013 | <b>Reestablish Service After the Shut-Off of a Main</b> | Standard Number:<br><b>GS 6500.130</b> |
| Supersedes:<br>11/15/1984     |   | Page 2 of 2                            |

tested as outlined in GS 1500.010 "Pressure Testing." The house lines shall also be tested using one of the test methods outlined in "Methods for Testing Existing Customers' House and/or Service Lines."



Distribution Operations

|                               |   |  |
|-------------------------------|---|--|
| Effective Date:<br>06/17/1996 | <b>Mechanical Joining on Customer Owned Plastic Service Lines or House Lines by Non-Company Personnel</b> | Standard Number:<br><b>GS 6500.140(CG)</b><br>P&P 725-14 |
| Supersedes:<br>N/A            |   | Page 1 of 2  |

Companies Affected:

|                                     |   |   |
|-------------------------------------|---|---|
| <input type="checkbox"/> NIPSCO     | <input checked="" type="checkbox"/> CGV | <input type="checkbox"/> CMD            |
| <input type="checkbox"/> NIFL       | <input checked="" type="checkbox"/> CKY | <input checked="" type="checkbox"/> COH |
| <input type="checkbox"/> Kokomo Gas | <input type="checkbox"/> CMA            | <input type="checkbox"/> CPA            |

**REFERENCE** Code of Federal Regulations - Title 49 - Part 192 - §§192.285 and 192.287

**1. GENERAL**

Mechanical joining on customer owned plastic service lines by non-company personnel shall only be performed by personnel qualified in making that particular joint.

**2. QUALIFICATION AND REQUALIFICATION**

The qualification and requalification of non-company personnel shall be in accordance with the back side of Form C-2300, "Mechanical Joints on Plastic Pipe," Exhibit A.

**3. ACCEPTANCE OF MECHANICAL JOINTS**

When a mechanical joint is made by a non-company person on a customer owned plastic service line, the non-company person making the joint will complete a tag, Form C-2300, "Mechanical Joints on Plastic Pipe." This tag indicates that the installer has been qualified to make the joint(s).

After completing the information on the tag, the person making the joint will affix it to the service line or meter set assembly.

When the service line is inspected by Company personnel, the tag will be removed and attached to the DIS Order that has been pre-pared to record the results of the inspection and test. When the tag is not left on the job, the installation shall not be approved.

Personnel who inspect mechanical joints on customer owned plastic service lines shall be trained to evaluate the acceptability of mechanical joints.

**4. RECORDING TRAINING**

Recording of training for non-company personnel is not required

*This document is considered CONTROLLED only when viewed electronically on the Company's intranet. Printed or other electronic copies may not be current, and the intranet version should be used to verify.*




**Gas Standard**

Distribution Operations

|                               |   |  |
|-------------------------------|---|--|
| Effective Date:<br>06/17/1996 | <b>Mechanical Joining on Customer Owned Plastic Service Lines or House Lines by Non-Company Personnel</b> | Standard Number:<br><b>GS 6500.140(CG)</b><br>P&P 725-14 |
| Supersedes:<br>N/A            |   | Page 2 of 2  |

**EXHIBIT A**



### Mechanical Joint Card

Please **PRINT CLEARLY**. (Contractor must complete all information on this side only)

Name: \_\_\_\_\_

Employer or Company Name: \_\_\_\_\_

Qualifying Agency: \_\_\_\_\_

Job Address or Location: \_\_\_\_\_

I attest that I made the joint(s) on this service line, meeting the requirements of being trained and qualified as stated below and installed the service line with Columbia Gas approved materials, as listed in the current Columbia Gas form C 2248, "Materials for Customer Service Lines".  
To be "trained and qualified" means the person signing this attestation:

- (1) has read and become familiar with installation instructions for joining plastic pipe; and
- (2) has had previous experience in the installation of joints in plastic pipe in accordance with the installation instructions; and
- (3) has had someone, who is already a qualified installer, examine the previous installation of joints made to verify the acceptability of the joints; and
- (4) has made such a previous acceptable installation of joints in the last 12 months (failure to have made such an acceptable installation in the last 12 months requires re-qualification under steps (1), (2), and (3)).

I further attest that I am enrolled in a Drug and Alcohol plan in accordance with 49 CFR 199.


Signature: \_\_\_\_\_ Date: \_\_\_\_/\_\_\_\_/\_\_\_\_

Note: Mechanical Joint Cards can be printed from website: [www.columbiagasohio.com/business/plumbers](http://www.columbiagasohio.com/business/plumbers) or [www.columbiagasohio.com/products\\_services/plumber\\_information.htm](http://www.columbiagasohio.com/products_services/plumber_information.htm)

FORM C 2300 (06-07)

---

### This Side for Columbia Use Only



PSID:

Comments: \_\_\_\_\_

\_\_\_\_\_

\_\_\_\_\_

\_\_\_\_\_

\_\_\_\_\_

\_\_\_\_\_

\_\_\_\_\_

\_\_\_\_\_

\_\_\_\_\_

\_\_\_\_\_

Name (print): \_\_\_\_\_ Date card picked up: \_\_\_\_/\_\_\_\_/\_\_\_\_

FRONT SIDE

BACK SIDE

PAPER: CARDSTOCK  
COLOR: CANARY YELLOW  
SIZE: 5 1/2" X 4 1/4"



Distribution Operations

Gas Standard

|                               |                            |  |
|-------------------------------|----------------------------|--|
| Effective Date:<br>10/27/2014 | <b>Lighting Appliances</b> | Standard Number:<br><b>GS 6500.150</b> |
| Supersedes:<br>05/01/2014     |                            | Page 1 of 3                            |

Companies Affected:

|                                 |   |   |
|---------------------------------|---|---|
| <input type="checkbox"/> NIPSCO | <input checked="" type="checkbox"/> CGV | <input checked="" type="checkbox"/> CMD |
|                                 | <input checked="" type="checkbox"/> CKY | <input checked="" type="checkbox"/> COH |
|                                 | <input checked="" type="checkbox"/> CMA | <input checked="" type="checkbox"/> CPA |

**REFERENCE** ANSI Z223.1, NFPA 54

### 1. GENERAL

This gas standard sets forth the requirements for safely placing gas appliances into operation and verifying their safe operation when lighting appliances is a requirement of the job order.

### 2. WHEN ESTABLISHING OR REESTABLISHING SERVICE

1. All service lines and/or house lines shall be tested in accordance with GS 6500.050 "Methods for Testing Customer Service Lines and/or House Lines," prior to lighting appliances.
2. Gas lines shall be purged using the purging procedure as contained in GS 6500.060 "Turning on Gas."
3. All properly installed gas burning appliances, except new heating equipment, shall be lit and checked for safe operation. The customer should be advised to contact the installer to place new heating equipment into operation. If the customer is not present, the heating equipment shall be turned off at the manual appliance valve and tagged instructing the customer to have the installer put the equipment into operation. The new heating equipment manufacturer's installation instructions should be left on the customers' premises.

### 3. PLACING APPLIANCES INTO OPERATION

1. Gas utilization equipment shall be given the following checks as applicable.
  - a. Check ignition safety device for proper operation (e.g. pilot safety, hot surface ignition, spark ignition).
  - b. Verify that the appliance is installed in a location in accordance with the terms of its listing - see appliance rating plate.
  - c. Check operating controls (e.g. thermostat, aquastat if boiler equipped with a domestic hot water coil).

*This document is considered CONTROLLED only when viewed electronically on the Company's intranet. Printed or other electronic copies may not be current, and the intranet version should be used to verify.*



**Distribution Operations**

**Gas Standard**

|                               |                            |  |
|-------------------------------|----------------------------|--|
| Effective Date:<br>10/27/2014 | <b>Lighting Appliances</b> | Standard Number:<br><b>GS 6500.150</b> |
| Supersedes:<br>05/01/2014     |                            | Page 2 of 3                            |

- d. Verify that electricity and/or water is on to the appliance if it is necessary for the safe operation of the appliance.
  - e. Verify the presence of safety devices, including, but not limited to the following.
    - i. High temperature limits.
    - ii. Low water cutoffs.
    - iii. Pressure controls.
    - iv. Temperature and/or pressure relief devices.
    - v. Flame roll out switches.
    - vi. Vent spill switches.
    - vii. Energy Cutoffs (ECO) on water heaters.
  - f. Observe flame characteristics for proper combustion.
  - g. Check for proper draft.
  - h. Check venting system for proper installation and safe operation.
  - i. Check for adequate ventilation and combustion air (i.e. confirm appliances are not installed in a confined space).
  - j. Observe thermostat temperature settings on heating equipment and return to "as found" settings unless customer requests otherwise.
  - k. Observe thermostat temperature setting on water heaters. Note and document on the job order "as found" and "as left" temperature settings. Advise the customer of scalding risk with temperature settings above 125 degrees F. If the customer is not present, the temperature setting should be returned to the "as found" setting and a note left for the customer advising them of scalding hazards if the "as found/as left" temperature setting exceeds 125 degrees F.
2. Appliances determined to be safe shall be left operational unless the customer requests otherwise.
  3. In the event an unsafe condition is discovered at an appliance(s), the gas to such appliance(s) shall be turned off and the appliance(s) shall be "red tagged" according to the applicable GS 6500.010 "Use of Red Tag on Appliances." The gas service may then be established for those appliances in safe condition.

#### **4. RECORDS**

Record appliances lit, left off at the customer request, new heating equipment that was left off, gas appliances that were not lit due to not having the required electricity and/or water, and equipment turned off and red tagged. Include the reason for the Red Tag on the job order. In addition, document any discussions with the customer on recommendations made





**Distribution Operations**

**Gas Standard**

|                               |                            |  |
|-------------------------------|----------------------------|--|
| Effective Date:<br>10/27/2014 | <b>Lighting Appliances</b> | Standard Number:<br><b>GS 6500.150</b> |
| Supersedes:<br>05/01/2014     |                            | Page 3 of 3                            |

regarding the installation of an appliance.

For DIS users, complete Form C-2997 "Premise Audit Form" for any changes to the status of an appliance installed on a customer's premise. This form is available in the Dupli online catalog located on the Company's intranet site.



Distribution Operations

|                               |   |  |
|-------------------------------|---|--|
| Effective Date:<br>11/30/1982 | <b>Meter Sorting and Loading for Shipping</b> | Standard Number:<br><b>GS 6500.170(CG)</b><br>P&P 725-17 |
| Supersedes:<br>N/A            |   | Page 1 of 5  |

Companies Affected:

|                                     |   |   |
|-------------------------------------|---|---|
| <input type="checkbox"/> NIPSCO     | <input checked="" type="checkbox"/> CGV | <input checked="" type="checkbox"/> CMD |
| <input type="checkbox"/> NIFL       | <input checked="" type="checkbox"/> CKY | <input checked="" type="checkbox"/> COH |
| <input type="checkbox"/> Kokomo Gas | <input type="checkbox"/> CMA            | <input checked="" type="checkbox"/> CPA |

**REFERENCE**    None

**1. GENERAL REQUIREMENTS**

Meters presently received in the meter shop are now sorted by meter shop personnel upon receipt. This time consuming operation can more easily be accomplished at most of our shipping locations. Where small areas send meters to a central shipping point, meters may be consolidated and sorted at the central location rather than in the small area. Meters properly sorted and stacked will flow smoothly into the operation of the meter shop.

Filling out of the Meter Shipping List will provide the area office and area shop with accurate information which can be used to check meter readings without the necessity of the meter shops searching through several thousand meters to verify a specific meter reading.

In general, meters are to be sorted for return to the meter shop in a manner similar to the way they are received from the meter shop.

**2. SORTING AND LOADING OF METERS ON CARTS OR PALLET CONTAINERS**

Meters shall be sorted at the meter shipping location and loaded on carts or pallet containers for return to the meter shop. Drivers shall refuse any shipment of meters that are improperly sorted and stacked. Sorting and stacking shall be done as follows:

- a. Ironcase, aluminum and tin meters shall be sorted into these three categories.
- b. Aluminum meters shall be sorted by manufacturer and by kind and size.
- c. From the time the meter is removed from the customer's premises until it is received at the meter shop, the meter shall be stored and shipped with caps installed and maintained in the upright position at all times.
- d. Special test meters shall be tagged with the applicable Meter Record Card and Request for Special Test of Meter Tag (Exhibit A), Form C 1689 and the truck driver notified that the shipment contains special test meter(s). If possible, meters to be tested shall be placed on the top layer of the cart or pallet container.

*This document is considered CONTROLLED only when viewed electronically on the Company's intranet. Printed or other electronic copies may not be current, and the intranet version should be used to verify.*



Distribution Operations

|                               |   |  |
|-------------------------------|---|--|
| Effective Date:<br>11/30/1982 | <b>Meter Sorting and Loading for Shipping</b> | Standard Number:<br><b>GS 6500.170(CG)</b><br>P&P 725-17 |
| Supersedes:<br>N/A            |   | Page 2 of 5  |

- e. Ironcase meters will be loaded only on the bottom two layers of the meter cart of pallet container. When it is necessary to put a third layer of meters on top of two layers of iron-case meters, the layer will be a single layer of aluminum or tin meters stacked in the upright position.
- f. Each layer of meters will be separated by the dividers that are shipped with the cart or pallet container. These dividers shall always be returned to the meter shop with the cart or pallet container.
- g. Where it becomes necessary to put meters of different heights on a single layer, the tallest meters will be placed in the corners and outside rows so that the separator board will set level.
- h. Meter carts prepared for shipment to the Columbus Meter Shop shall be wrapped to prevent meters from falling off carts. The wrapping will be done at the shipping point prior to being loaded on the meter truck by the meter shop truck driver unless the personnel at the location are equipped to do this wrapping.

**3. COMPLETING THE METER SHIPPING LIST**

The completion of a Meter Shipping List serves two purposes. First, it allows office personnel to verify readings after meters have been sent to the meter shop. Meter shop personnel will not have to search for meters in the meter shop to verify readings. Second, it allows management to keep an ongoing inventory of our meter population.

The Meter Shipping List is the only way to verify a reading once it has been sent to the meter shop, the accuracy of this reading cannot be over emphasized. The serial number and meter reading must be taken from the meter and not from the Meter Record Card.

The Meter Shipping List (Exhibit B) shall be completed with the following information:

- a. The date the shipment is made.
- b. The location number from which the shipment is made.
- c. The location number or Meter Shop where the meters are being shipped.
- d. The serial number of each meter contained on the cart or pallet container.
- e. The kind and side code of each meter.
- f. The meter reading from each meter.

The Meter Shipping List is printed in triplicate and copies of the completed form are to be



Distribution Operations

|                               |   |  |
|-------------------------------|---|--|
| Effective Date:<br>11/30/1982 | <b>Meter Sorting and Loading for Shipping</b> | Standard Number:<br><b>GS 6500.170(CG)</b><br>P&P 725-17 |
| Supersedes:<br>N/A            |   | Page 3 of 5  |

distributed as follows:

- Original      Retain at the shipping point
- Copy 1      Send to the Division/Area Office
- Copy 2      Given to the truck driver transporting the meters to the meter shop or control shipping point.

When meters are sent from a small area to a central shipping point, the inventory will be made at the small area location. When the meters are sorted at the central shipping location, it will not be necessary to re-inventory these meters for shipping to the meter shop as long as the number of meters in the meter shipment agrees with the Meter Shipping Lists given to the truck driver.



Gas Standard

Distribution Operations

|                               |   |  |
|-------------------------------|---|--|
| Effective Date:<br>11/30/1982 | <b>Meter Sorting and Loading for Shipping</b> | Standard Number:<br><b>GS 6500.170(CG)</b><br>P&P 725-17 |
| Supersedes:<br>N/A            |   | Page 4 of 5  |

EXHIBIT A

FORM C 1689 CSD (11-74) COLUMBIA GAS DISTRIBUTION COMPANIES (OSS) REQUEST FOR SPECIAL TEST OF METER

|                     |  |                                  |   |         |
|---------------------|--|----------------------------------|---|---------|
| TYPE TEST REQUESTED | <input checked="" type="checkbox"/> COMPLAINT <input type="checkbox"/> OFFICE <input type="checkbox"/> REFEREE |                                  | CUSTOMER DEPOSIT  | DATE    |
|                     |  |                                  | <input checked="" type="checkbox"/> YES <input type="checkbox"/> NO               | 3/12/79 |
| METER               | REASON FOR TEST<br><i>Customer Request</i>   |                                  | TEST ORDERED BY   |         |
|                     | CUSTOMER NAME<br><i>John Doe</i>   |                                  | METER KIND AND SIZE<br><i>Pgh 5</i>   |         |
|                     | ADDRESS<br><i>2857 W. Monroe St</i>  |                                  | METER NUMBER<br><i>985079</i>   |         |
|                     | CUSTOMER'S ACCOUNT NUMBER<br><i>06-15-1200-2</i>   |                                  | DATE SET<br><i>7-2-75</i>   |         |
| REMOVAL             | DATE OF REMOVAL<br><i>3-15-79</i>  | LOCAL OFFICE NO.<br><i>41525</i> | READING<br><i>876.1</i>   |         |
|                     | Meter Found <i>1.8</i> % Fast _____ % Slow   |                                  | Mechanical Defects Found After Tests<br><input type="checkbox"/> SEE REVERSE SIDE |         |
| TEST RESULTS        | METER TESTED BY<br><i>J.C. Bethel</i>  | DATE<br><i>3/22/79</i>           | TEST WITNESSED BY<br><i>Jay Fairchance</i>  |         |
|                     | TEST REPORTED TO CUSTOMER BY: <input type="checkbox"/> PHONE <input checked="" type="checkbox"/> LETTER        |                                  | DATE<br><i>3-29-79</i>  |         |

BLUE-Meter Shop and Return to Local Office; Green-Local Office; White-Meter Shop, Attach to Meter



**Gas Standard**

Distribution Operations

|                               |   |  |
|-------------------------------|---|--|
| Effective Date:<br>11/30/1982 | <b>Meter Sorting and Loading for Shipping</b> | Standard Number:<br><b>GS 6500.170(CG)</b><br>P&P 725-17 |
| Supersedes:<br>N/A            |   | Page 5 of 5  |

**EXHIBIT B**

**COLUMBIA GAS**  
Distribution Companies



**METER SHIPPING LIST**

Sheet \_\_\_\_\_ of \_\_\_\_\_

| DATE SHIPPED:       |                | FROM LOCATION NO. | TO LOCATION NO.     | OR TO METER SHOP                     |         |                                     |                |                                   |  |
|---------------------|----------------|-------------------|---------------------|--------------------------------------|---------|-------------------------------------|----------------|-----------------------------------|--|
|                     |                |                   |                     | <input type="checkbox"/> BETHEL PARK |         | <input type="checkbox"/> CHARLESTON |                | <input type="checkbox"/> COLUMBUS |  |
| METER SERIAL NUMBER | KIND/SIZE CODE | READING           | METER SERIAL NUMBER | KIND/SIZE CODE                       | READING | METER SERIAL NUMBER                 | KIND/SIZE CODE | READING                           |  |
| 1                   |                |                   | 26                  |                                      |         | 51                                  |                |                                   |  |
| 2                   |                |                   | 27                  |                                      |         | 52                                  |                |                                   |  |
| 3                   |                |                   | 28                  |                                      |         | 53                                  |                |                                   |  |
| 4                   |                |                   | 29                  |                                      |         | 54                                  |                |                                   |  |
| 5                   |                |                   | 30                  |                                      |         | 55                                  |                |                                   |  |
| 6                   |                |                   | 31                  |                                      |         | 56                                  |                |                                   |  |
| 7                   |                |                   | 32                  |                                      |         | 57                                  |                |                                   |  |
| 8                   |                |                   | 33                  |                                      |         | 58                                  |                |                                   |  |
| 9                   |                |                   | 34                  |                                      |         | 59                                  |                |                                   |  |
| 10                  |                |                   | 35                  |                                      |         | 60                                  |                |                                   |  |
| 11                  |                |                   | 36                  |                                      |         | 61                                  |                |                                   |  |
| 12                  |                |                   | 37                  |                                      |         | 62                                  |                |                                   |  |
| 13                  |                |                   | 38                  |                                      |         | 63                                  |                |                                   |  |
| 14                  |                |                   | 39                  |                                      |         | 64                                  |                |                                   |  |
| 15                  |                |                   | 40                  |                                      |         | 65                                  |                |                                   |  |
| 16                  |                |                   | 41                  |                                      |         | 66                                  |                |                                   |  |
| 17                  |                |                   | 42                  |                                      |         | 67                                  |                |                                   |  |
| 18                  |                |                   | 43                  |                                      |         | 68                                  |                |                                   |  |
| 19                  |                |                   | 44                  |                                      |         | 69                                  |                |                                   |  |
| 20                  |                |                   | 45                  |                                      |         | 70                                  |                |                                   |  |
| 21                  |                |                   | 46                  |                                      |         | 71                                  |                |                                   |  |
| 22                  |                |                   | 47                  |                                      |         | 72                                  |                |                                   |  |
| 23                  |                |                   | 48                  |                                      |         | 73                                  |                |                                   |  |
| 24                  |                |                   | 49                  |                                      |         | 74                                  |                |                                   |  |
| 25                  |                |                   | 50                  |                                      |         | 75                                  |                |                                   |  |

|              |      |             |      |                           |
|--------------|------|-------------|------|---------------------------|
| COMPLETED BY | DATE | VERIFIED BY | DATE | TOTAL NO. METERS SHIPPED: |
|--------------|------|-------------|------|---------------------------|



Distribution Operations

|                               |   |  |
|-------------------------------|---|--|
| Effective Date:<br>12/20/1984 | <b>Private Well Gas Usage by CDC<br/>Customer</b> | Standard Number:<br><b>GS 6500.180(CG)</b><br>P&P 725-18 |
| Supersedes:<br>N/A            |   | Page 1 of 8  |

Companies Affected:

|                                     |   |   |
|-------------------------------------|---|---|
| <input type="checkbox"/> NIPSCO     | <input checked="" type="checkbox"/> CGV | <input checked="" type="checkbox"/> CMD |
| <input type="checkbox"/> NIFL       | <input checked="" type="checkbox"/> CKY | <input checked="" type="checkbox"/> COH |
| <input type="checkbox"/> Kokomo Gas | <input type="checkbox"/> CMA            | <input checked="" type="checkbox"/> CPA |

**REFERENCE** National Fuel Gas Code, N.F.P.A. 54-ANSI Z223.1

**1. GENERAL**

This policy and procedure shall be followed in all known cases where a Columbia Gas customer elects to tie house lines into an alternate source of gas from a private well.

**2. CODES AND REGULATIONS**

Gas piping installed on the customers' premises must be in accordance with the National Fuel Gas Code, N.F.P.A. 54 - A.N.S.I. Z223.1, and Form C 2235, "Standards for Gas Piping on Customers' Premises."

CDC may discontinue gas service when the customer's gas piping system does not conform with the above codes and regulations.

**3. DESIGN AND CONSTRUCTION REQUIREMENTS**

**3.1 Customer Notification of Intent or Existing System**

If a customer notifies CDC of intentions to tie in private well gas to a house line, or when a customer's system is found to be supplied by private well gas, the customer shall be requested to submit a sketch showing the proposed or existing installation. This sketch shall conform to the requirements of Section 3.2 and 3.3. The tie-in shall be made on the customer's house line.

**3.2 Residential and Commercial Customers**

A residential or commercial customer is required to provide and install, at the customer's expense, a multiport valve at the point of tie-in of the two sources of gas. Exhibit A depicts the operation of multiport valves. Exhibit B shows the correct placement and minimum requirements when using a multiport valve.

A multiport valve will provide isolation and maximum protection for the customer and

*This document is considered CONTROLLED only when viewed electronically on the Company's intranet. Printed or other electronic copies may not be current, and the intranet version should be used to verify.*



Distribution Operations

|                               |  |  |
|-------------------------------|--|--|
| Effective Date:<br>12/20/1984 | <b>Private Well Gas Usage by CDC<br/>                 Customer</b> | Standard Number:<br><b>GS 6500.180(CG)</b><br>P&P 725-18 |
| Supersedes:<br>N/A            |  | Page 2 of 8  |

the Gas Company's distribution system and metering equipment by preventing the back flow of private well gas into CDC's system. It also will prevent the flow of any Company gas into the well should the well pressure drop below the pressure supplied by the gas Company.

**3.3 Industrial Customers**

**3.3.1 Multiport Valves**

When possible, an industrial customer should provide and install, at the customer's expense, a multiport valve (Exhibit B) to isolate the Gas Company's system from the private well gas system to provide maximum protection and safety of operation.

A multiport valve is required when the gas supplied is from a company low pressure main because the pressure is insufficient to overcome the weight of the swing check valve flapper or disc in a check valve.

**3.3.2 Check Valves**

If a multiport valve is not used, check valves are required upstream of Gas Company regulation and recommended upstream of customer regulation where there is sufficient pressure to open the flappers. Exhibit C shows a recommended arrangement of equipment. Check valves must not be used where they cannot be installed upstream of pounds-to-pounds or pounds-to-inches regulation.

The system shown in Exhibit C should be used only when the customer insists on having an automatic switchover to Gas Company gas in the event his well pressure drops below a pre-determined level, and when there is sufficient pressure in the Company's line to operate a check valve (the drop across any check valve is closed to 1 psig).

**4. TURN-ON NOTIFICATION AND TESTING**

After the customer has tied in the well gas and before consuming any well gas, the customer shall notify the Gas Company that the gas supply system is completed and ready for inspection. A Gas Company representative will inspect the installation to assure that the system complies with company specifications. At this time the customer service line and the customer's house piping will be leak tested. The Gas Company representative should also be present when the well gas is turned on to assure that all equipment required by this





Distribution Operations

|                               |   |  |
|-------------------------------|---|--|
| Effective Date:<br>12/20/1984 | <b>Private Well Gas Usage by CDC<br/>Customer</b> | Standard Number:<br><b>GS 6500.180(CG)</b><br>P&P 725-18 |
| Supersedes:<br>N/A            |   | Page 3 of 8  |

procedure is operating properly.

**5. MAINTENANCE RESPONSIBILITY**

The customer will be responsible for conducting periodic maintenance inspections and checks of all customer-owned and installed equipment to assure continued safe and trouble-free operation of the system. This inspection will include all gas well system equipment such as pipelines, valves, regulators, separators, drips, etc.

The Gas Company will respond to customer calls of odor of gas, no gas, or low pressure. However, the customer will be invoiced for a service call if it is found that the problem is the result of the well gas service.

The Gas Company may conduct inspections of the system as deemed necessary to assure safe operation of Company equipment.

**6. LETTER OF AGREEMENT**

In every known case where a customer has private well gas tied into house lines, the Gas Company shall have on file a letter of agreement and understanding (Exhibit D) which has been signed by the customer. This letter stipulates the special conditions under which the Gas Company will provide gas service and terms to which the customer has agreed by signing the letter.



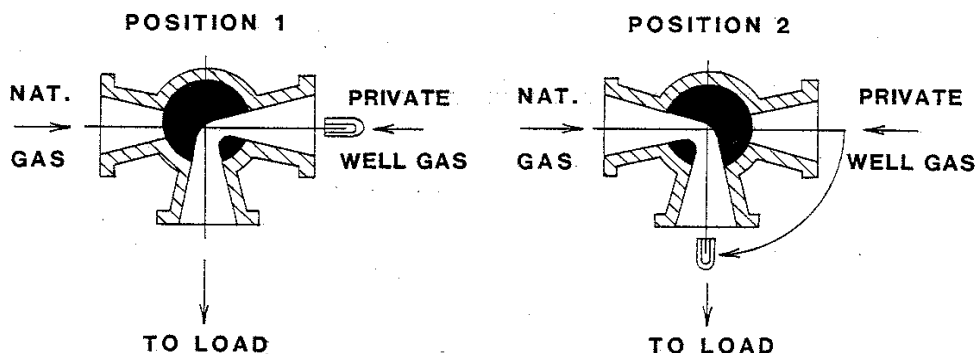
Distribution Operations

|                               |   |  |
|-------------------------------|---|--|
| Effective Date:<br>12/20/1984 | <b>Private Well Gas Usage by CDC<br/>Customer</b> | Standard Number:<br><b>GS 6500.180(CG)</b><br>P&P 725-18 |
| Supersedes:<br>N/A            |   | Page 4 of 8  |

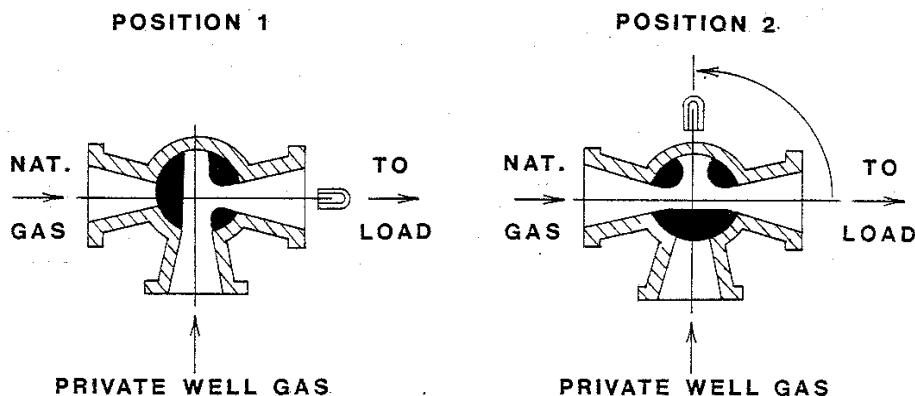
EXHIBIT A

**MULTI-PORT VALVES**  
90 DEGREE TURN - TWO POSITIONS

(☞ = FACTORY SET STOP)



3-WAY, 2-PORT



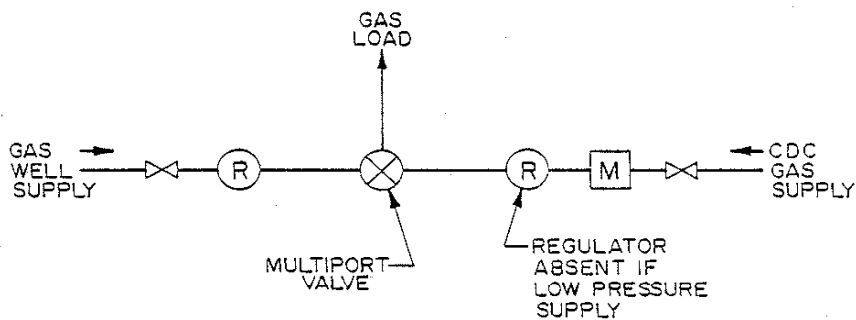
3-WAY, 3-PORT



Distribution Operations

|                               |   |  |
|-------------------------------|---|--|
| Effective Date:<br>12/20/1984 | <b>Private Well Gas Usage by CDC<br/>Customer</b> | Standard Number:<br><b>GS 6500.180(CG)</b><br>P&P 725-18 |
| Supersedes:<br>N/A            |   | Page 5 of 8  |

EXHIBIT B



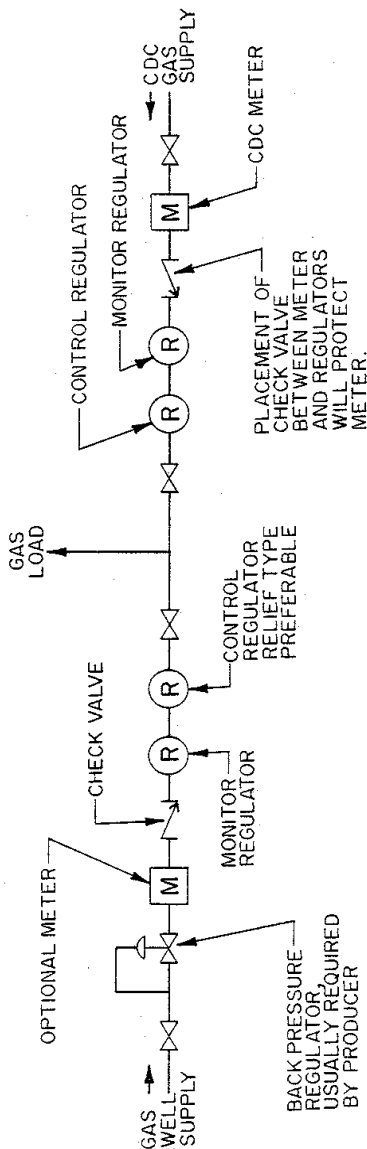
MINIMUM REQUIREMENTS WHEN USING  
MULTIPOINT VALVE



Distribution Operations

|                               |   |  |
|-------------------------------|---|--|
| Effective Date:<br>12/20/1984 | <h2>Private Well Gas Usage by CDC Customer</h2> | Standard Number:<br><b>GS 6500.180(CG)</b><br>P&P 725-18 |
| Supersedes:<br>N/A            |   | Page 6 of 8  |

EXHIBIT C



RECOMMENDED ARRANGEMENT OF EQUIPMENT FOR SAFE  
 GAS SERVICE WHEN MULTIPORT VALVE IS NOT USED



**Gas Standard**

Distribution Operations

|                               |   |  |
|-------------------------------|---|--|
| Effective Date:<br>12/20/1984 | <b>Private Well Gas Usage by CDC<br/>Customer</b> | Standard Number:<br><b>GS 6500.180(CG)</b><br>P&P 725-18 |
| Supersedes:<br>N/A            |   | Page 7 of 8  |

**EXHIBIT D  
(1 of 2)**

Dear

This letter will serve as our agreement and understanding with respect to the use of gas from the well(s) serving your property at

\_\_\_\_\_ .

Because of various potential safety and operating problems, Columbia Gas does not recommend the use of private well gas by persons lacking a thorough understanding of the technical operation and design of private gas well systems. If, however, you choose to utilize such a system, it is to be connected between the outlet side of Columbia's metering and regulating equipment and the inlet of the gas-fueled company on your property.

Your private gas well system shall be designed and installed in accordance with the National Fuel Gas Code N.F.P.A. 54 - A.N.S.I. Z223.1, and all other federal, state and local codes and regulations that may apply. Before using your system you will contact local building and fire department officials having jurisdiction in your location and make certain that your installation is in compliance with all local regulations.

A three-way multiport valve shall be installed by you at the connection of the Columbia natural gas line and the customer well line, unless other equipment is specified by Columbia Gas.

You will notify us prior to the initial start-up of your well system. Before the system is placed into operation, Columbia will inspect it to insure that it will not adversely affect the safe operation of our metering facilities. The house lines, service lines, and Gas Company metering and regulating facilities will be subject to routine inspections and leak detection checks.

You must notify Columbia Gas of any additional gas equipment that is installed prior to the operation of such equipment so that Columbia can be certain that its facilities are adequate to meet any additional demand. You will also notify Columbia Gas of any modification of your piping system and permit inspection.

Columbia may, at its discretion, discontinue gas service if it determines that your system is not in conformance with codes, regulations or Company standards and will not reestablish service until necessary corrections are made.



**Gas Standard**

Distribution Operations

|                               |   |  |
|-------------------------------|---|--|
| Effective Date:<br>12/20/1984 | <b>Private Well Gas Usage by CDC<br/>Customer</b> | Standard Number:<br><b>GS 6500.180(CG)</b><br>P&P 725-18 |
| Supersedes:<br>N/A            |   | Page 8 of 8  |

**EXHIBIT D  
(2 of 2)**

The responsibility for providing safe gas service from your well system is yours. We will not be responsible for any malfunction of your well line, house lines, service lines, or gas appliances associated with your system. You will indemnify us against, and hold us harmless from, any and all claims, actions, suits, proceeding, costs, expenses, damages and liabilities, including attorney fees, arising out of, connected with, or resulting from any malfunction of your well lines, house lines, service lines or gas appliances associated with your well system, which causes injury or damage to your person or property or to the person or property of others. Since this agreement will apply to any successor in interest, lessee, or sub-lessee of the premises subject to this agreement, you must advise Columbia of any such change in possession or ownership of the subject property.

If you agree with the foregoing terms, kindly sign on the appropriate line below and return to us.

Very truly yours,

I/We agree with the above terms.

\_\_\_\_\_

By: \_\_\_\_\_

Date:



Distribution Operations

|                               |   |  |
|-------------------------------|---|--|
| Effective Date:<br>01/12/1994 | <b>New or Replaced Customer Owned<br/>Steel Service Lines</b> | Standard Number:<br><b>GS 6500.190(CG)</b><br>P&P 725-19 |
| Supersedes:<br>N/A            |   | Page 1 of 24   |

Companies Affected:

|                                     |   |   |
|-------------------------------------|---|---|
| <input type="checkbox"/> NIPSCO     | <input checked="" type="checkbox"/> CGV | <input checked="" type="checkbox"/> CMD |
| <input type="checkbox"/> NIFL       | <input checked="" type="checkbox"/> CKY | <input checked="" type="checkbox"/> COH |
| <input type="checkbox"/> Kokomo Gas | <input type="checkbox"/> CMA            | <input type="checkbox"/> CPA            |

**REFERENCE** Code of Federal Regulations - Title 49 - Part 192

**1. GENERAL**

Company personnel should discourage the installation of steel customer owned service lines when the MAOP is 60 psig or less. However, when requested, Company personnel shall provide advice and guidance to a customer, plumber and other persons involved with the installation of the steel customer service line regarding materials, installation of piping and location of the meter set assembly. It is the responsibility of the customer, plumber and other persons to install the service line consistent with the advice and guidance provided.

**2. SIZING**

In sizing the customer owned steel service line, the entire service line (Company service plus the customer owned service line) shall be treated as a unit. The minimum size steel customer service line shall be 1 inch IPS.

[GS 2120.020\(CG\)](#) "Service Line Sizing" reflects the sizing requirements for the entire service line (main to meter set assembly).

**3. MATERIALS**

Refer to Form C-2248, "Materials for Customer Service Lines."

**3.1 Steel Service Pipe**

Either standard or extra heavy weight black steel pipe shall be used for underground metallic service lines. Pipe shall be manufactured in accordance with API Specification 5L, "Specification for Line Pipe."

The service line piping and fit-tings shall be coated and cathodically protected. Corrosion control materials and their applications are described in Exhibit A.

*This document is considered CONTROLLED only when viewed electronically on the Company's intranet. Printed or other electronic copies may not be current, and the intranet version should be used to verify.*



Distribution Operations

|                               |   |  |
|-------------------------------|---|--|
| Effective Date:<br>01/12/1994 | <b>New or Replaced Customer Owned<br/>Steel Service Lines</b> | Standard Number:<br><b>GS 6500.190(CG)</b><br>P&P 725-19 |
| Supersedes:<br>N/A            |   | Page 2 of 24   |

**3.2 Mechanical Fittings**

Mechanical fittings listed in Form C 2248 shall be used in joining pipe underground. Metal fittings under-ground shall be coated and wrapped in accordance with Exhibit A.

**3.3 Screw Fittings**

Screw fittings shall be used above ground only. When screw fittings are used, the threads shall meet the requirements of ANSI B2.1, "American National Standard for Pipe Threads (Except Dryseal)."

Bushings, all-thread nipples and cast-iron fittings are not permitted in the service line.

Unions are not permitted except above ground in the meter set assembly provided by the Company.

**4. LOCATION**

The route of the service line is determined by the location of the meter set assembly and main. In selecting the location of the service line, consideration shall be given to the best location for the meter set assembly and location of the connection on the main.

It is preferred that the service line be installed in a continuous straight line from the main to service entry into the building and the entry be above grade. Whether the entry is above or below grade, the service line entry shall be cased. See Exhibits B and C. Galvanized steel sleeves are not permitted below grade.

It is permissible for the customer service line to enter the side-wall of the building. When the service line does parallel the outside wall for a distance of more than three feet it shall be installed not less than three feet from the wall to a point opposite the meter set assembly or point of entry.

**5. INSTALLATION**

**5.1 General**

Each length of steel pipe shall be examined before installation, and any dirt or obstruction removed. Burrs left when cutting the pipe shall be reamed off.

Pipe, fittings and valves removed from any existing service line installation shall not be used again until they are thoroughly cleaned, inspected and determined to be adequate for the service intended.





Distribution Operations

|                               |   |  |
|-------------------------------|---|--|
| Effective Date:<br>01/12/1994 | <b>New or Replaced Customer Owned<br/>Steel Service Lines</b> | Standard Number:<br><b>GS 6500.190(CG)</b><br>P&P 725-19 |
| Supersedes:<br>N/A            |   | Page 3 of 24   |

When the customer steel service line must be installed into an unexcavated portion of a building in order to reach the meter set assembly, the service line shall be encased in coated steel pipe. The casing shall start at least one foot outside the foundation wall entry and extend at least six inches into the unexcavated portion of the building. The ends of the casing shall be sealed, preferably by welding. The casing annular space shall be vented outside the building. The vent shall extend at least one (1) foot above grade and be fitted with an approved vent fitting. See Exhibit B.

When the service line is installed through a foundation wall or floor containing reinforcing rods, precautions shall be taken to prevent the carrier pipe or casing from directly contacting the reinforcing rods.

The customer service line shall not be laid under concrete or other hard surface, except when necessary to cross under walks or driveways. Where the hard surface extends from curb to foundation wall and eight feet or more on either side of the service line, such as at service stations or other places of business, a vent shall be installed over the line near the foundation wall, See Exhibit D.

## 5.2 Trenching

The customer service line shall be laid on undisturbed or well compacted soil in a separate uniformly graded trench, except where joint trenching with other utility services such as plastic water pipe and television cables not encased in metal conduit, is practical. The customer service line shall not be run through septic tanks or leaching beds, laid in the same trench with sewer piping or electrical cables or laid below un-jointed ceramic field tile. It shall not be laid on a bench or offset of a deeper trench.

Where it is necessary for electrical or telephone conduits or water pipe to pass either over or under the service line underground, there shall be at least six inches of clearance.

The customer service line installed in a separate trench shall have a minimum cover of 12 inches. Where joint trenching is used, the gas pipe and other utility services shall be installed at a minimum depth of 18 inches in a ditch not less than 24 inches in width. The gas and water services shall be separated laterally as much as possible. Television cables may be installed between the water and gas piping provided six inches of clearance is maintained.



Distribution Operations

|                               |   |  |
|-------------------------------|---|--|
| Effective Date:<br>01/12/1994 | <b>New or Replaced Customer Owned<br/>Steel Service Lines</b> | Standard Number:<br><b>GS 6500.190(CG)</b><br>P&P 725-19 |
| Supersedes:<br>N/A            |   | Page 4 of 24   |

**5.3 Joining**

Where it is necessary to use more than one length of pipe in the customer service line, the lengths shall be joined by either an approved mechanical fitting or welding. The protective coating shall be cut back and removed from the end of the pipe. The cutback shall be of sufficient length to allow for the assembly of the fitting on bare steel pipe or to prevent the coating material from contaminating the weld. Only plain end pipe is permitted in the makeup of compression type or welded joints.

Where offsets are required, swing joints or smooth pipe bends shall be used. The swing joints can be comprised of two 90° compression lock type ells and a short pipe nipple, or a compression lock type street ell and one 90° compression lock type ell (See Exhibit F). Pipe bends shall be made in such a way that they are free from buckling, cracks or other evidence of physical damage.

Screw fittings are not permitted underground.

All coating of underground fittings, welds, and exposed metallic piping damaged during pipe bending shall be coated in accordance with Exhibit A.

Form C-2575, "Certification of Welder Qualifications Sticker," Exhibit E, shall be completed by the contractor, owner, or owner's representative, and attached to the DIS Order by the serviceman at the time of the inspection.

**5.4 Welding Qualifications**

Welding should be accomplished by either the oxyacetylene or the electric arc process. Welding procedures and welders performing work on the customer's piping systems shall be qualified under requirements of CFR Title 49-Part 192 - Section 192.227 and subject to the limitations set forth in Section 192.229. The contractor, owner, or owner's representative shall certify that the welding was performed by a qualified welder by signing form C-2575, "Certification of Welder Qualifications Sticker," Exhibit E.

**5.5 Backfilling**

The Company inspector will conduct an open ditch inspection prior to backfilling.

The customer shall be advised that:

- a. Heavy equipment shall not be run over the service line trench immediately after



Distribution Operations

|                               |   |  |
|-------------------------------|---|--|
| Effective Date:<br>01/12/1994 | <b>New or Replaced Customer Owned<br/>Steel Service Lines</b> | Standard Number:<br><b>GS 6500.190(CG)</b><br>P&P 725-19 |
| Supersedes:<br>N/A            |   | Page 5 of 24   |

it has been backfilled.

- b. Material used for the backfill and in contact with the pipe shall be free of rocks, building materials, etc. that might cause damage to the pipe or its coating.
- c. Cinders and slag should not be used in the backfill.
- d. Monitoring of the backfill is the responsibility of the installer of the customer owned steel service line.

**5.6 Risers**

**5.6.1 Outside Meter Setting**

An approved coated steel service line riser shall be installed at the inlet of all outside meter set assemblies. See Exhibit F.

The riser shall be installed in such a position that the completed meter set assembly will allow approximately six inches clearance between the bottom of the meter and the finished grade.

Where a riser passes through a walk, patio or drive-way, it shall be installed through a sleeve or other means of providing a space between the riser and the walk, patio or driveway. The space between the sleeve and riser shall be filled with gravel. See Exhibit G.

**5.6.2 Outside Riser, Inside Meter Setting**

When the meter is to be located inside and the entry is to be above-ground, an approved coated steel riser shall be installed in accordance with the requirements in Section 5.6.1.

**5.6.3 Inside Riser, Inside Meter Setting**

Where a meter is to be located inside the basement and the service line enters the structure below grade, the riser should be installed to allow sufficient height for the meter set assembly. See Exhibit B. The riser shall be installed not less than 6 inches from the wall. All inside service line piping shall be exposed and accessible.



Distribution Operations

|                               |   |  |
|-------------------------------|---|--|
| Effective Date:<br>01/12/1994 | <b>New or Replaced Customer Owned<br/>Steel Service Lines</b> | Standard Number:<br><b>GS 6500.190(CG)</b><br>P&P 725-19 |
| Supersedes:<br>N/A            |   | Page 6 of 24   |

**6. ELECTRICAL ISOLATION**

New steel customer service lines shall be coated and cathodically protected, as detailed in Exhibit A, and electrically isolated from any metallic Company service line by the use of an insulating fitting. The insulating fitting will be installed, by the Company, on the outlet side of the curb valve. See Exhibit H.

An insulating fitting is required to be installed in the meter set assembly, preferably as part of the meter valve, to electrically isolate the house piping and electric, water, and telephone utilities from the customer service line.

Where the inlet piping to a single meter set assembly is 2 inches or larger, an insulating union, flange or coupling shall be installed in the setting above ground and downstream of the meter valve to electrically isolate the steel service line from the house lines. (Refer to [GS 1420.070](#) "Corrosion Control Design-Electrical Isolation and Insulation.")

**7. CATHODIC PROTECTION EVALUATION AND MONITORING**

Each new customer owned steel service line shall be evaluated by the Company to determine the effectiveness of the cathodic protection within one year after installation. After a customer's steel service line has been evaluated as being cathodically protected, it shall be monitored by the Company. (See [GS 1460.010](#) "Corrosion Remedial Measures Distribution" or [GS 1460.020](#) "Corrosion Remedial Measures Transmission.") The Company will evaluate and correct or have corrected defective cathodic protection systems within 12 months.

**8. CORROSION CONTROL TEST POINTS**

A means of electrical contact to the steel customer owned service lines shall be provided during installation. This allows the Company to conduct periodic electrical tests and evaluate the level of cathodic protection. Refer to [GS 1460.010](#) "Corrosion Remedial Measures Distribution" or [GS 1460.020](#) "Corrosion Remedial Measures Transmission."

A customer service riser outside of the building will normally be sufficient to provide this electrical contact.

If the Company main and service lines are metallic:

- a. A two wire test station installation shall be installed adjacent to the curb box, Exhibit I, if an outside riser does not exist.
- b. A four wire test station, Exhibit J, in stray current areas shall be installed, regardless of the availability of electrical contact through an above ground riser, to



Distribution Operations

|                               |   |  |
|-------------------------------|---|--|
| Effective Date:<br>01/12/1994 | <b>New or Replaced Customer Owned<br/>Steel Service Lines</b> | Standard Number:<br><b>GS 6500.190(CG)</b><br>P&P 725-19 |
| Supersedes:<br>N/A            |   | Page 7 of 24   |

mitigate the effects of stray currents.

**9. RECORDS FOR CUSTOMERS' STEEL SERVICE LINES**

Each District shall establish a means for providing the Corrosion personnel with a copy of Form C-2641, "Service Line Order," Exhibit K, marked "corrosion control copy," showing the service line location, length, date of installation and location of the curb valve insulator test station (if installed).

Each two and four wire test point installations shall be recorded on Form C-1282-17, "Annual Log of Metallic Mains Installed," Exhibit L, and identified as customer service lines.



Distribution Operations

|                               |   |  |
|-------------------------------|---|--|
| Effective Date:<br>01/12/1994 | <b>New or Replaced Customer Owned<br/>Steel Service Lines</b> | Standard Number:<br><b>GS 6500.190(CG)</b><br>P&P 725-19 |
| Supersedes:<br>N/A            |   | Page 8 of 24   |

**EXHIBIT A  
(1 of 5)**

**PROTECTIVE COATING SYSTEMS AND CATHODIC PROTECTION**

**A. Protective Coating Systems**

**1. General**

Underground steel customer owned service lines and fittings shall be provided with a protective coating system. The protective coating system on the pipe shall extend to a point at least 4 inches above finished grade. The coating system selected for use shall consist of a coating and compatible primer that retards corrosion. The coating and primer used shall be selected from Form C 2248, "Materials for Customer Service Lines."

**2. Approved Coatings for Fittings and Joints and Repair of Damaged Pipe Coatings**

The following types of coatings are approved for use in the coating of fittings, joints, and relatively short lengths of underground metallic pipe and the repair of damage to the mill coating on gas piping. Hot applied tapes or coatings shall not be applied as a corrosion retarding material on transition fittings used to join plastic pipe to steel pipe.

**a. Hot-Applied Tapes**

These tapes are coal tar enamels and resins reinforced with an outerwrap or mesh to form a tape type coating. They are applied using a "cigarette" or "spiral" hand wrap method with a minimum 1/2 inch overlap, and heated with a low temperature torch. All of these tapes must be applied over an approved coal tar primer. The manufacturers' directions for application shall be followed in applying these tapes.

**b. Cold-Applied Laminated Tapes**

These tapes are made of coal tar resins or butyl type coatings, and laminated to a plastic film. They are applied over their respective primer in a "cigarette" or "spiral" wrap using a minimum 1/2 inch overlap. The manufacturers' directions for application shall be followed in applying these tapes.



Distribution Operations

|                               |  |  |
|-------------------------------|--|--|
| Effective Date:<br>01/12/1994 | <b>New or Replaced Customer Owned<br/>                 Steel Service Lines</b> | Standard Number:<br><b>GS 6500.190(CG)</b><br>P&P 725-19 |
| Supersedes:<br>N/A            |  | Page 9 of 24   |

**EXHIBIT A  
 (2 of 5)**

**c. Wax Type Coatings - Hot-Applied**

These coatings are microcrystalline type waxes that are applied over a primer either by flood coating, or brush, after heating to the manufacturer's recommended temperatures. They are particularly suited for coating thermit weld connections, as well as for patching and fittings work. These materials must be applied in conformance with the manufacturer's directions.

Primers approved for use with wax type coatings are the same as those primers listed for Cold-Applied Laminated Tapes.

**d. Mastic Type Coatings - Cold-Applied**

These mastic type coatings are asphalt or coal tar emulsions that are applied over cleaned steel by brushing or daubing. They require 30 to 90 minutes' drying time. Backfilling before the coating dries will permit soil clods to penetrate the coating. No primer is required. They are best suited for patching pre-coated fittings and for coating thermit welds.

**e. Coal Tar Enamels - Hot-Applied**

These coatings are normally applied at a pipe coating mill but may be used in the field. They must be heated in a fired pot to approximately 400° Fahrenheit and applied by floodcoating over an approved coal tar primer and wrapped with a 15 lb. asphalt saturated felt. These materials must be applied in conformance with the manufacturers' directions.

**f. Polyvinyl Chloride and Epoxy Coatings - Factory-Applied**

These coatings are factory-applied to fittings by an extrusion or fluidized bed process. The thickness of these coatings is such that, with care, a pipe wrench will not cut through the surface to metal during make-up. A band type wrench, however, is recommended for use in installing fittings coated with these materials. Damaged areas on fittings and pipe coating cutback shall be repaired.



Distribution Operations

|                               |   |  |
|-------------------------------|---|--|
| Effective Date:<br>01/12/1994 | <b>New or Replaced Customer Owned<br/>Steel Service Lines</b> | Standard Number:<br><b>GS 6500.190(CG)</b><br>P&P 725-19 |
| Supersedes:<br>N/A            |   | Page 10 of 24  |

**EXHIBIT A  
(3 of 5)**

**3. Application**

**a. Surface Preparation**

The metallic surface shall be cleaned of oil, grease, rust, mud, paint, mill scale, and other foreign materials. Remove rust scale and foreign materials by cutters, knives and brushes or a combination of these tools.

**b. Application of Primers**

The primer used shall be of the grade and type for the coating to be applied. The primer shall be thoroughly agitated before application. The primer shall be applied in a thin, even coating, free of runs, drips, or thick spots. Accumulations of primer at welds and all heavy concentration of primer shall be brushed out by hand.

**c. Application of Coatings**

The coating shall be applied to the primed metal surface which is free of dirt, dust, and moisture. The primer for coal tar coatings shall be dry and free of all residual solvent. The coal tar coating shall be heated to the manufacturer's recommended coating temperature. Care shall be exercised not to overheat the coal tar base coatings or subject them to high heat for long periods of time.

The protective coatings shall be applied in compliance with the recommendations and specifications of the coating manufacturer. The coating application shall in all cases be performed in a quality workmanship manner.

**4. Handling and Installing**

Coated pipe shall be handled in a manner that protects the coating from damage. It shall not be dropped, rolled or impacted against solid objects with a force capable of causing damage to the coating. The pipe ditch shall be free of rocks, stones, skids, scrape metal or other solid objects which can damage the coating. The backfill material shall be free of rocks, stones or other heavy objects which might injure the coating during the backfilling operation.





Distribution Operations

|                               |   |  |
|-------------------------------|---|--|
| Effective Date:<br>01/12/1994 | <b>New or Replaced Customer Owned<br/>Steel Service Lines</b> | Standard Number:<br><b>GS 6500.190(CG)</b><br>P&P 725-19 |
| Supersedes:<br>N/A            |   | Page 11 of 24  |

**EXHIBIT A  
(4 of 5)**

**5. Protective Coatings for Exposed Pipe and Fittings**

A non-metallic base painting system specifically designed and manufactured for protection of steel structures shall be applied to above ground outdoor piping.

The paint system shall be applied by brush, roller or spray in accordance with the recommendation and specifications of the manufacturer. The pipe surface shall be free of rust, scale, dirt, dust, grease, water or other surface contamination.

**B. Cathodic Protection**

New or replaced underground steel pipe and service line risers except mill-coated pre-fabricated service line risers equipped with an anode shall be protected from corrosion by the installation of magnesium anodes. This protection shall be in addition to and supplement the protective coatings.

The installation of a magnesium anode is not required in those specific cases where the Company representative authorizes an exception based on cathodic protection being provided by other means. The Company shall be consulted if other means of cathodic protection are desired.

**1. Magnesium Anodes**

Magnesium anodes installed shall be high purity magnesium alloy. Refer to Form C 2248, "Materials for Customer Service Lines," for a list of approved manufacturers.

**2. Anode Installations**

A 5 pound or larger magnesium anode shall be installed on each 2 inch or smaller steel service line of 100 feet or less. The anode shall be buried a minimum distance of 2 feet from the pipe at or below trench depth and shall be installed approximately midway between the meter set assembly and the curb valve.

A steel service line 2 inches or smaller and longer than 100 feet shall have an additional 5 pound or larger magnesium anode installed for each additional 100 feet or portion thereof. The additional anode(s) shall be spaced approximately 100 feet apart.



Distribution Operations

|                               |   |  |
|-------------------------------|---|--|
| Effective Date:<br>01/12/1994 | <b>New or Replaced Customer Owned<br/>Steel Service Lines</b> | Standard Number:<br><b>GS 6500.190(CG)</b><br>P&P 725-19 |
| Supersedes:<br>N/A            |   | Page 12 of 24  |

**EXHIBIT A  
(5 of 5)**

**3. Anode Lead Attachment**

The anode lead wire shall be attached to the steel piping by the thermit weld process using a maximum charge of 15 gram. The pipe shall be cleaned to metal for the attachment of the lead wire.

The pipe at the lead wire attachment area shall be cleaned of slag, dirt or contamination and shall be primed and coated with a coating material compatible to the pipe coating.

When fittings are supplied with crimp connectors, the thermit weld is not necessary. Coating of the crimp connector is required.

Backfilling shall be in a manner that will not damage or remove the lead wire from the pipe.



**Gas Standard**

Distribution Operations

|                               |   |  |
|-------------------------------|---|--|
| Effective Date:<br>01/12/1994 | <b>New or Replaced Customer Owned<br/>Steel Service Lines</b> | Standard Number:<br><b>GS 6500.190(CG)</b><br>P&P 725-19 |
| Supersedes:<br>N/A            |   | Page 13 of 24  |

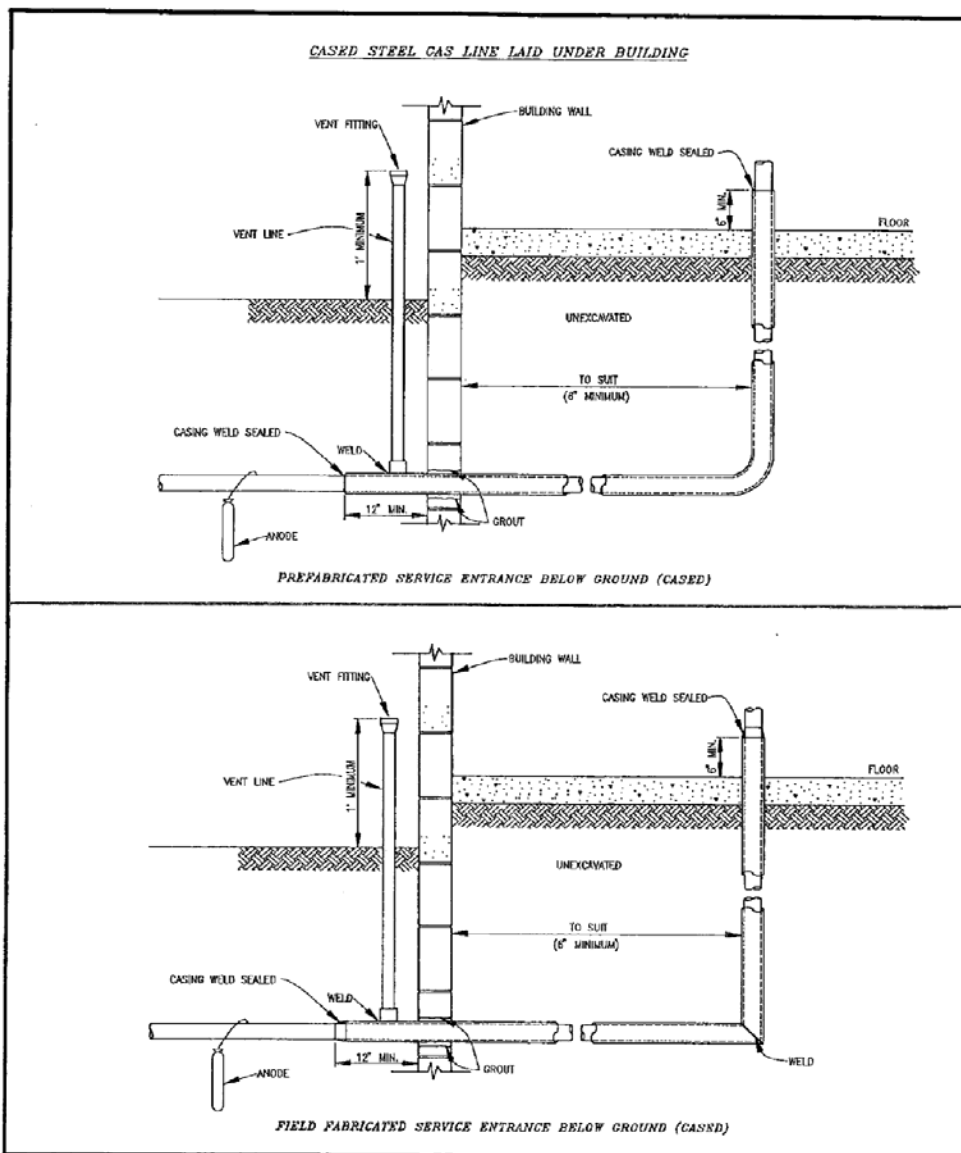
THIS PAGE INTENTIONALLY LEFT BLANK



Distribution Operations

|                               |   |  |
|-------------------------------|---|--|
| Effective Date:<br>01/12/1994 | <b>New or Replaced Customer Owned<br/>Steel Service Lines</b> | Standard Number:<br><b>GS 6500.190(CG)</b><br>P&P 725-19 |
| Supersedes:<br>N/A            |   | Page 14 of 24  |

EXHIBIT B

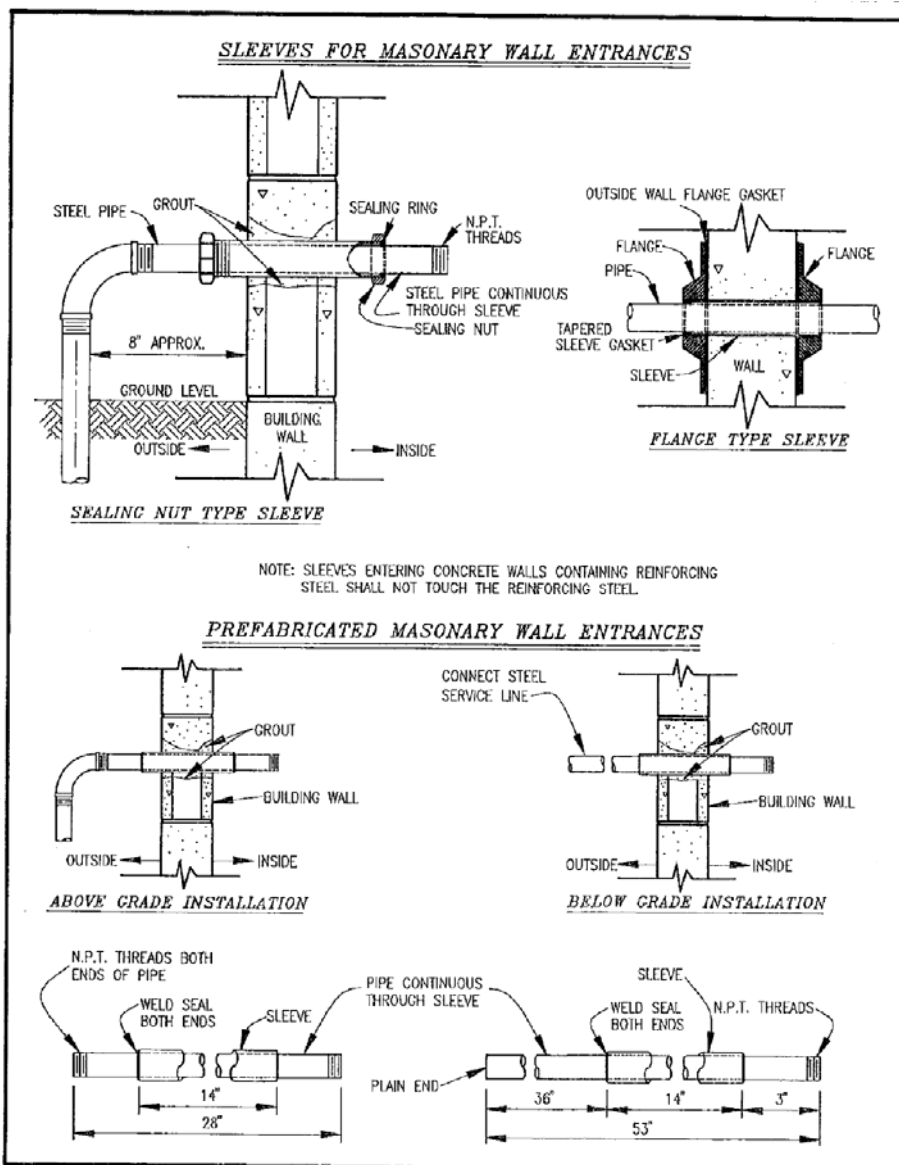




Distribution Operations

|                               |  |  |
|-------------------------------|--|--|
| Effective Date:<br>01/12/1994 | <h2 style="margin: 0;">New or Replaced Customer Owned<br/>Steel Service Lines</h2> | Standard Number:<br><b>GS 6500.190(CG)</b><br>P&P 725-19 |
| Supersedes:<br>N/A            |  | Page 15 of 24  |

EXHIBIT C



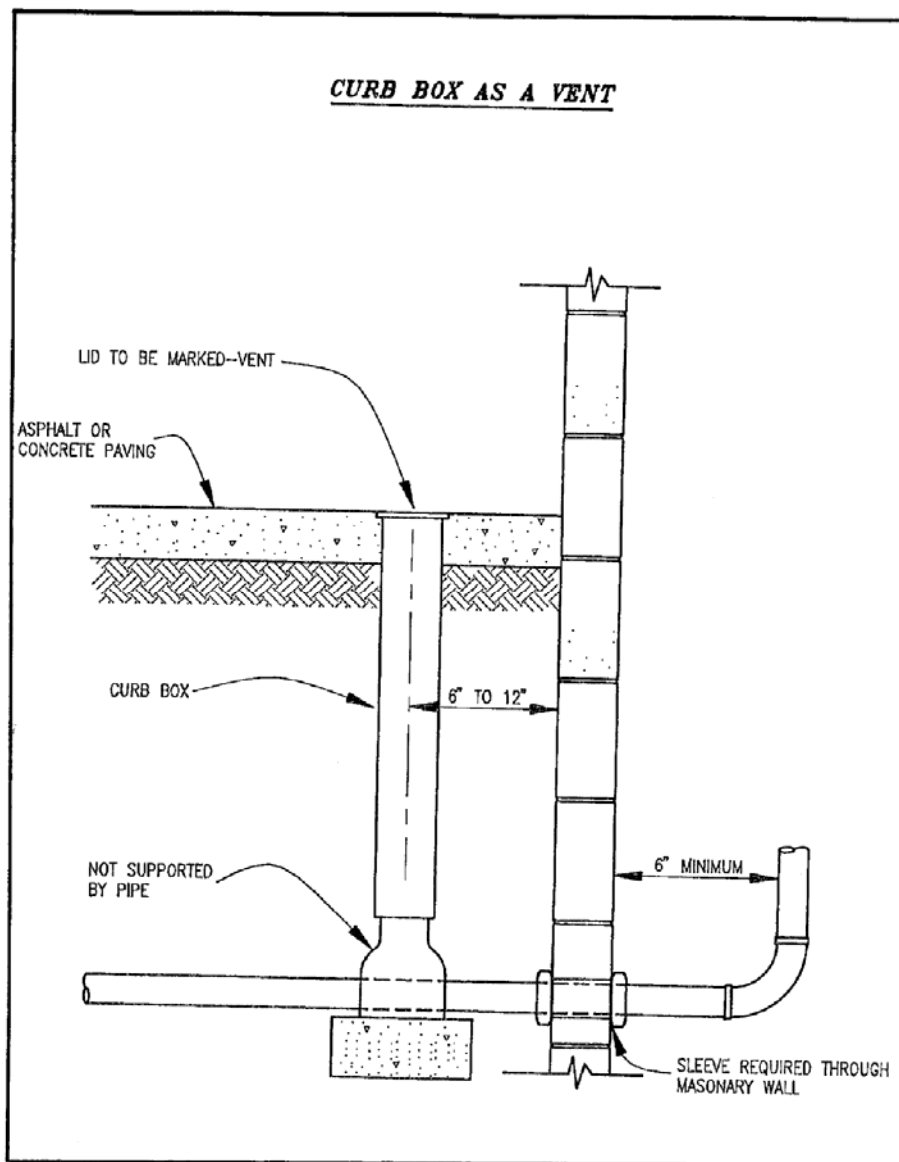


**Gas Standard**

Distribution Operations

|                               |   |  |
|-------------------------------|---|--|
| Effective Date:<br>01/12/1994 | <b>New or Replaced Customer Owned<br/>Steel Service Lines</b> | Standard Number:<br><b>GS 6500.190(CG)</b><br>P&P 725-19 |
| Supersedes:<br>N/A            |   | Page 16 of 24  |

**EXHIBIT D**





Distribution Operations

|                               |   |  |
|-------------------------------|---|--|
| Effective Date:<br>01/12/1994 | <b>New or Replaced Customer Owned<br/>Steel Service Lines</b> | Standard Number:<br><b>GS 6500.190(CG)</b><br>P&P 725-19 |
| Supersedes:<br>N/A            |   | Page 17 of 24  |

**EXHIBIT E**

FORM C 2575 CSD  
**CERTIFICATION OF WELDER QUALIFICATIONS**

I certify that the service and/or house lines  
installed at \_\_\_\_\_  
Address

have been welded by a qualified welder (or  
welders) as defined in Section 192.227 and  
192.229 of the Code of Federal Regulations;  
Title 49 Part 192 – “Transportation of Natural  
and Other Gas by Pipelines; Minimum Federal  
Safety Standards.”

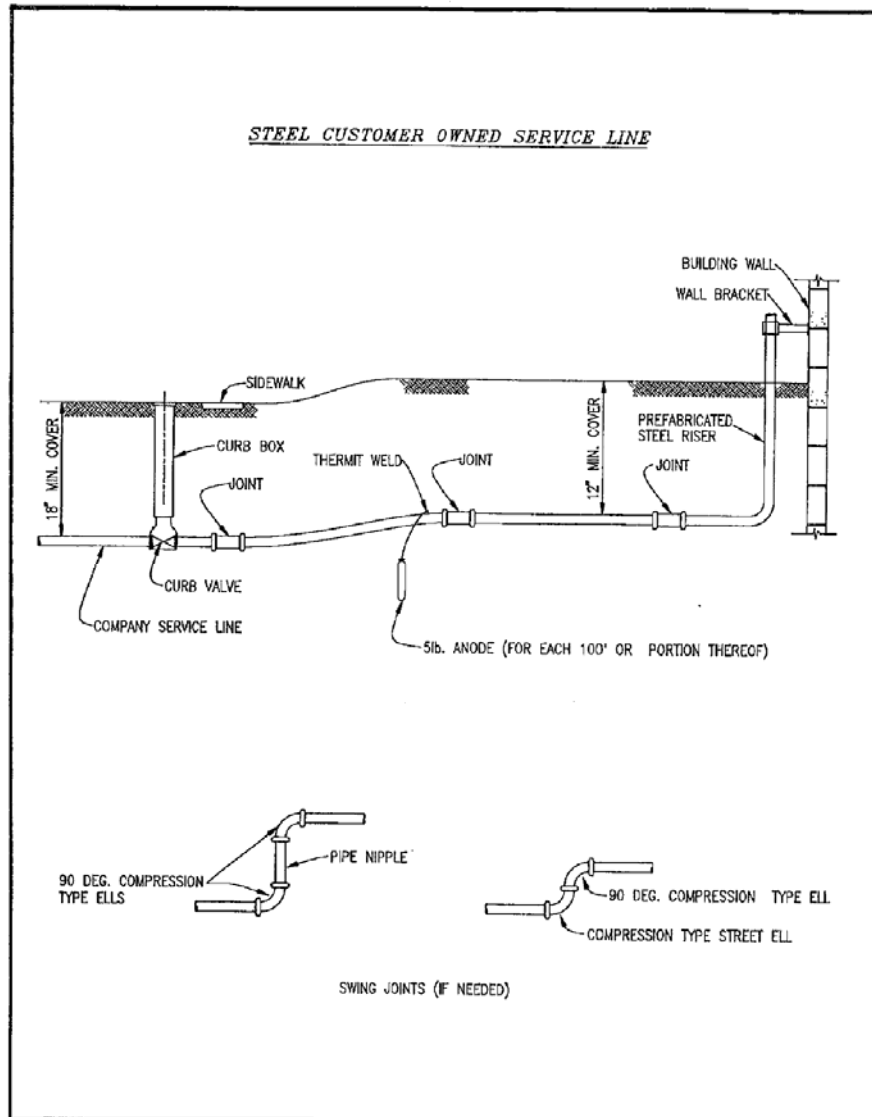
\_\_\_\_\_  
Contractor, Owner or Owner’s Representative      Date



Distribution Operations

|                               |   |  |
|-------------------------------|---|--|
| Effective Date:<br>01/12/1994 | <b>New or Replaced Customer Owned<br/>Steel Service Lines</b> | Standard Number:<br><b>GS 6500.190(CG)</b><br>P&P 725-19 |
| Supersedes:<br>N/A            |   | Page 18 of 24  |

EXHIBIT F



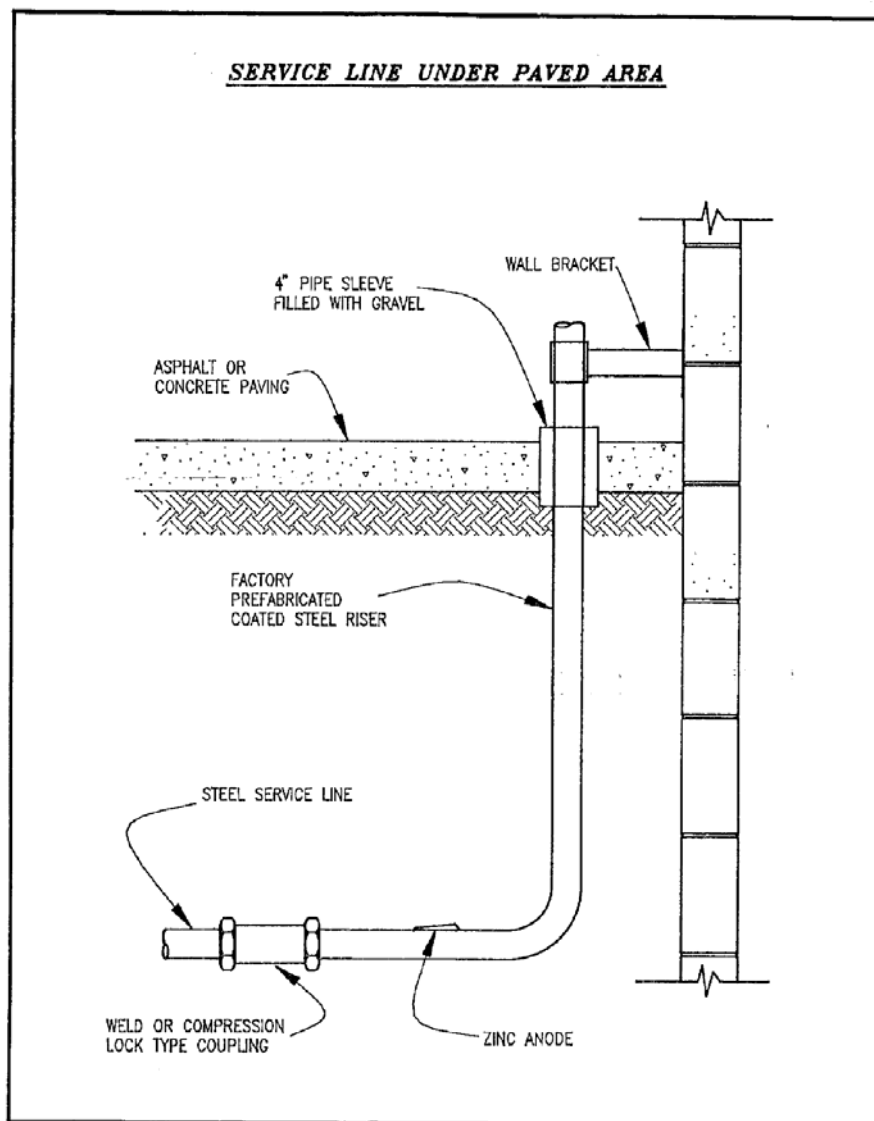




Distribution Operations

|                               |   |  |
|-------------------------------|---|--|
| Effective Date:<br>01/12/1994 | <b>New or Replaced Customer Owned<br/>Steel Service Lines</b> | Standard Number:<br><b>GS 6500.190(CG)</b><br>P&P 725-19 |
| Supersedes:<br>N/A            |   | Page 19 of 24  |

EXHIBIT G

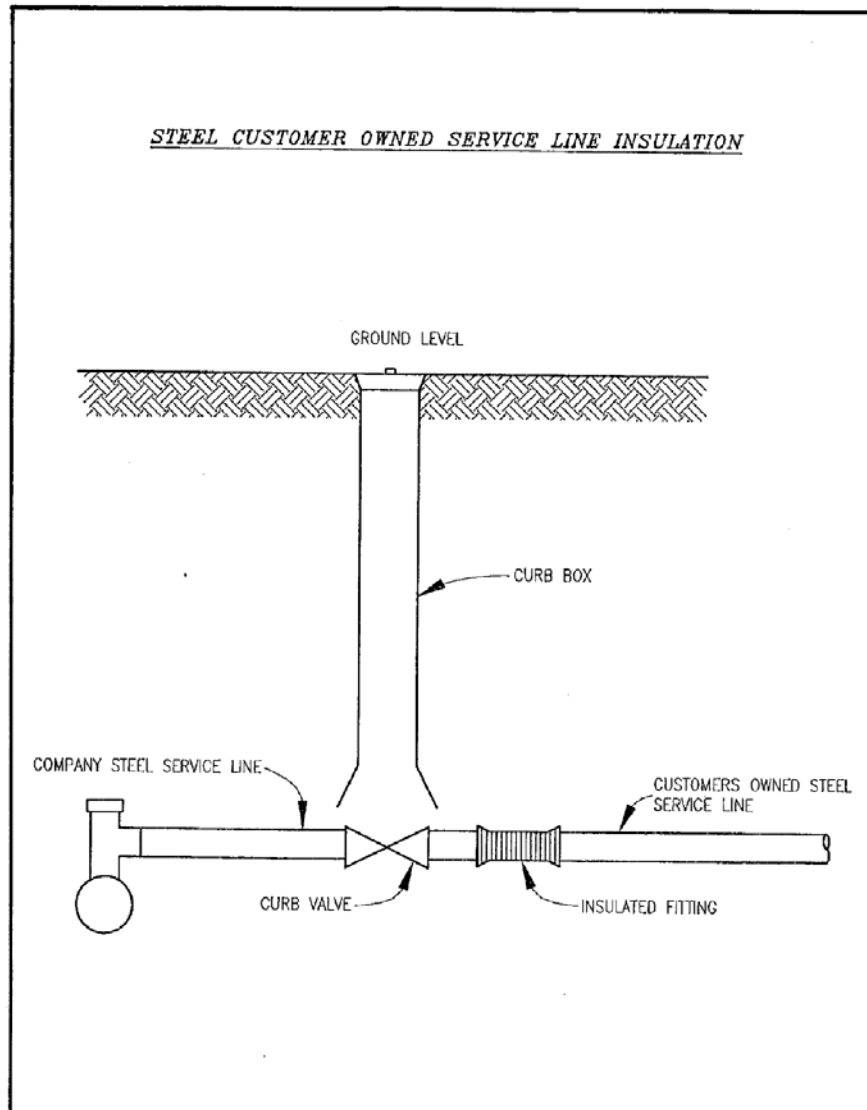




Distribution Operations

|                               |   |  |
|-------------------------------|---|--|
| Effective Date:<br>01/12/1994 | <b>New or Replaced Customer Owned<br/>Steel Service Lines</b> | Standard Number:<br><b>GS 6500.190(CG)</b><br>P&P 725-19 |
| Supersedes:<br>N/A            |   | Page 20 of 24  |

EXHIBIT H

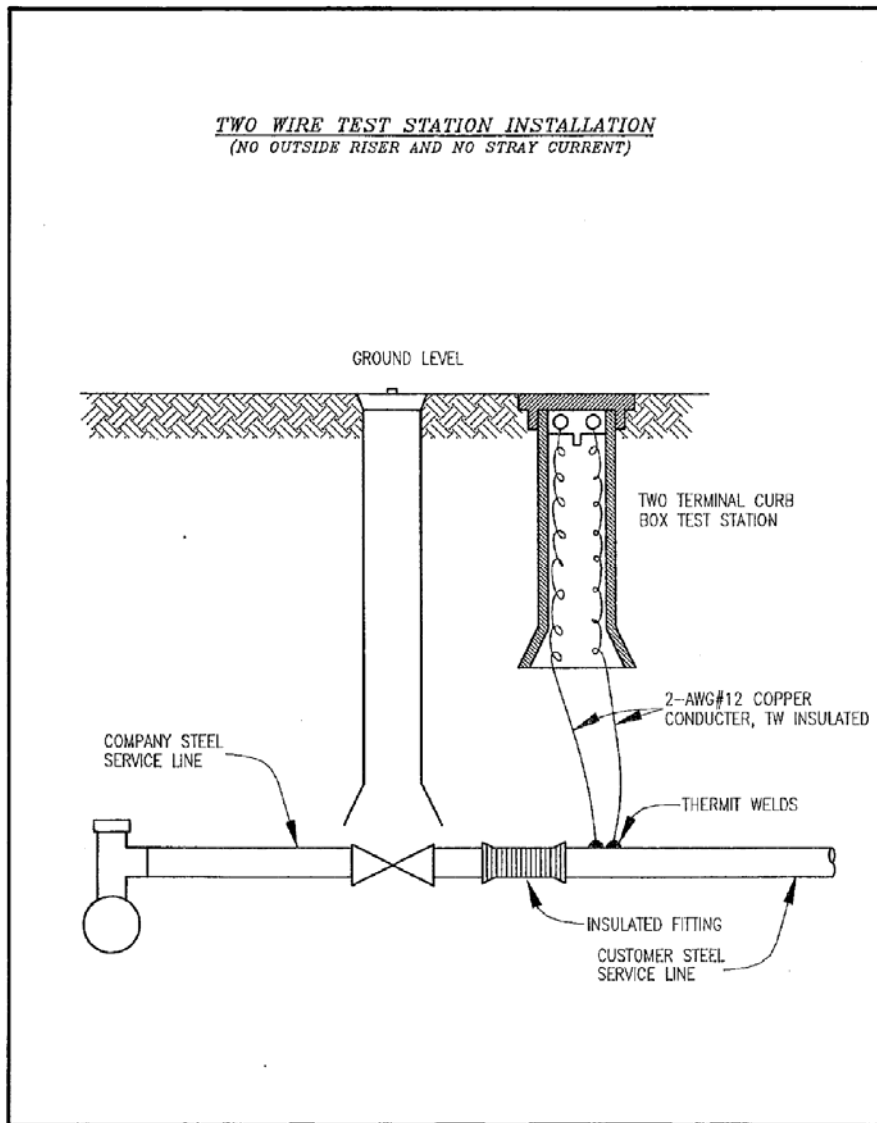




Distribution Operations

|                               |   |  |
|-------------------------------|---|--|
| Effective Date:<br>01/12/1994 | <b>New or Replaced Customer Owned<br/>Steel Service Lines</b> | Standard Number:<br><b>GS 6500.190(CG)</b><br>P&P 725-19 |
| Supersedes:<br>N/A            |   | Page 21 of 24  |

EXHIBIT I

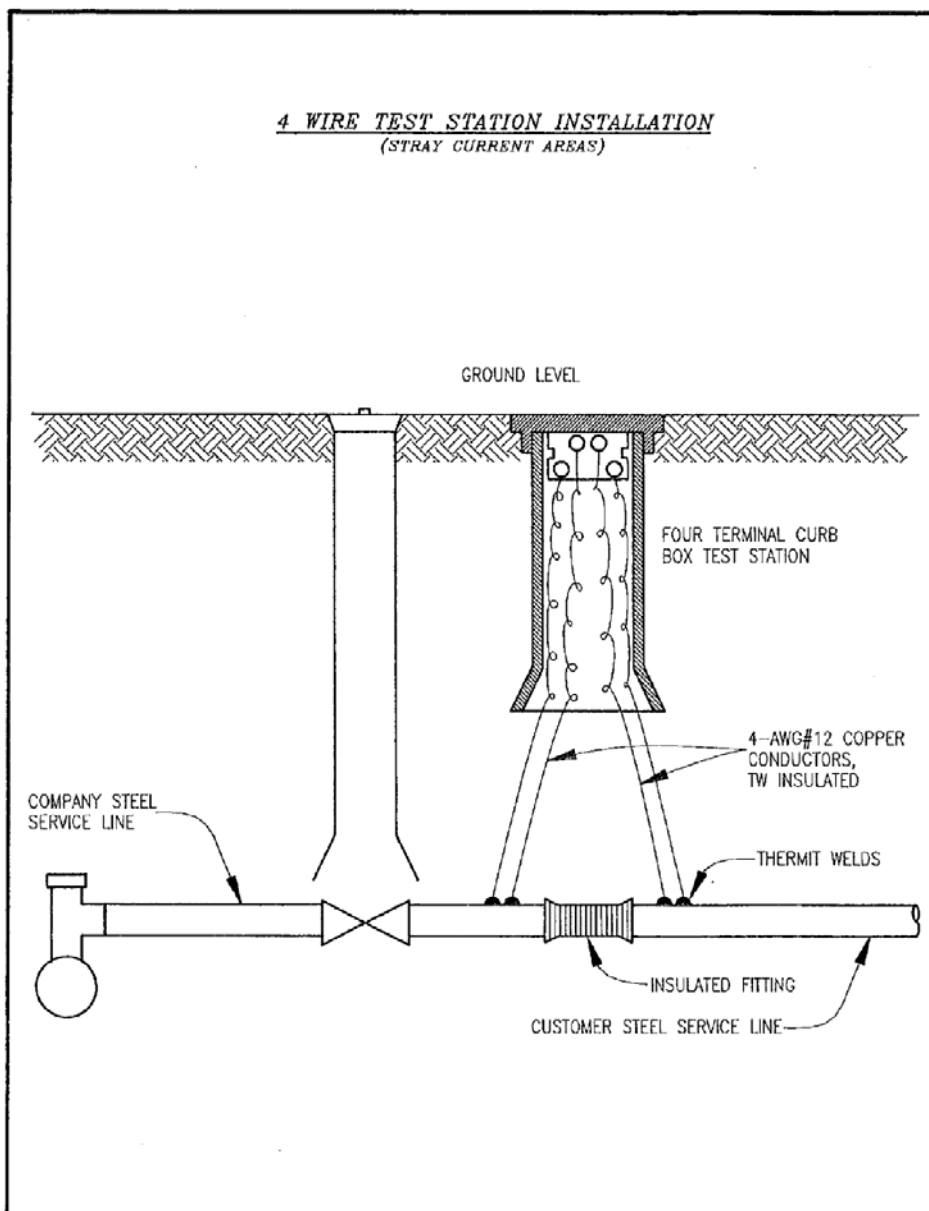




Distribution Operations

|                               |   |  |
|-------------------------------|---|--|
| Effective Date:<br>01/12/1994 | <b>New or Replaced Customer Owned<br/>Steel Service Lines</b> | Standard Number:<br><b>GS 6500.190(CG)</b><br>P&P 725-19 |
| Supersedes:<br>N/A            |   | Page 22 of 24  |

EXHIBIT J





**Gas Standard**

Distribution Operations

|                               |   |  |
|-------------------------------|---|--|
| Effective Date:<br>01/12/1994 | <b>New or Replaced Customer Owned<br/>Steel Service Lines</b> | Standard Number:<br><b>GS 6500.190(CG)</b><br>P&P 725-19 |
| Supersedes:<br>N/A            |   | Page 23 of 24  |

**EXHIBIT K**

**MATERIAL**

| DESCRIPTION                                  | SIZE    | QUAN-<br>TITY | STOCK SYMBOL NO | DESCRIPTION      | SIZE | QUAN-<br>TITY | STOCK SYMBOL NO |
|--|---------|---------------|-----------------|------------------|------|---------------|-----------------|
| PIPE   | STEEL   |               |                 | CURB BOX         |      |               |                 |
|  | PLASTIC |               |                 | C.B. SUPPORT     |      |               |                 |
|  |         |               |                 | ANODE            |      |               |                 |
| <small>MATERIALS COATING AND WEIGHTS</small> |         |               |                 |                  |      |               |                 |
| CURB VALVE                                   | COMP.   |               |                 | SER. BOX EXT.    |      |               |                 |
| COUR. LING                                   | COMP.   |               |                 | STIFFENER        |      |               |                 |
| ELL  | COMP.   |               |                 | SLEEVES, PLASTIC |      |               |                 |
|  | PLASTIC |               |                 |                  |      |               |                 |
| TEE  | PUNCH   |               |                 |                  |      |               |                 |
|  | PLASTIC |               |                 |                  |      |               |                 |

| TRANSFER NUMBER | CO. BLD. | DEF. LED. | AUX. | SUBSID. | OTHER | C.E. | STORER OVER | ABANDON OR RETIREMENT |   |   |
|-----------------|----------|-----------|------|---------|-------|------|-------------|-----------------------|---|---|
|                 |          |           |      |         |       |      |             | 1                     | 2 | 3 |
| CREDIT          | LOC.     | DEBIT     |      |         |       |      |             |                       |   |   |

ISSUED BY \_\_\_\_\_

FORM C 2541 GSD (2-90) COLUMBIA GAS DISTRIBUTION COMPANIES  NEW PG  ABANDON (A)  SURVEY (S)  REPAIR (R)  REPLACE (R)

**SERVICE LINE ORDER**

|  |                 |         |                        |                                  |             |                           |  |  |             |      |
|--|-----------------|---------|------------------------|----------------------------------|-------------|---------------------------|--|--|-------------|------|
| SERVICE ADDRESS  |                 |         |                        |                                  |             |                           |  |  |             | CITY |
| PSID NUMBER  |                 |         | TAXING DISTRICT NO.    |                                  |             | MAIN NUMBER               |  |  | OPER. PRES. |      |
| MAP NUMBER   |                 |         | MAIN SIZE/MAT'L        |                                  |             | MAIN REFERENCE (LOCATION) |  |  | SER. CAT.   |      |
| LENGTH OF SER.   | SER. SIZE/MAT'L | SPECIAL | DATE INSTALLED (M-D-Y) | REPAIR (R) DATE (M-D-Y)          | REPAIR KIND |                           |  |  |             |      |
| MT MT PSID OR LOCATION   |                 |         |                        | MASTER TAP REFERENCE ADDRESS     |             |                           |  |  |             |      |
| CURB BOX LOCATION OR PSID  |                 |         |                        | CURB BOX REFERENCE ADDRESS       |             |                           |  |  |             |      |
| CUST. VALVE LOCATION OR PSID   |                 |         |                        | CUSTOMER VALVE REFERENCE ADDRESS |             |                           |  |  |             |      |
| GEOGRAPHIC INFORMATION:  |                 |         |                        |                                  |             | SKETCH                    |  |  |             |      |
|  |                 |         |                        |                                  |             |                           |  |  |             |      |
| TESTED ACCORDING TO PIP* <input type="checkbox"/> CO. <input type="checkbox"/> CUST SERV <input type="checkbox"/> HOUSE LINE |                 |         |                        |                                  |             | BY (SIGNATURE)            |  |  |             |      |

\*IF SERVICE OPERATES AT OR ABOVE 20% SMTS, RECORD TEST PRESSURE, DURATION AND MEDIUM ON BACK OF THIS FORM

NOTE: FORM TO BE REVISED



**Gas Standard**

Distribution Operations

|                               |  |  |
|-------------------------------|--|--|
| Effective Date:<br>01/12/1994 | <b>New or Replaced Customer Owned<br/>                 Steel Service Lines</b> | Standard Number:<br><b>GS 6500.190(CG)</b><br>P&P 725-19 |
| Supersedes:<br>N/A            |  | Page 24 of 24  |

**EXHIBIT L**

| <b>ANNUAL LOG OF METALLIC MAINS INSTALLED</b> |     |                   |     |     |    |         |          |            |         |                      |                      |             |  |  |
|---|-----|-------------------|-----|-----|----|---------|----------|------------|---------|----------------------|----------------------|-------------|--|--|
| COMPANY                                       |     | CREATING LOCATION |     |     |    |         | DISTRICT |            | YEAR    |                      |                      |             |  |  |
| JOB CROSSER NUMBER                            | CMD | COH               | CPA | CQS | ON | BETWEEN | AND      | MAP NUMBER | FOOTAGE | J.O. IN SERVICE DATE | C.P. EVALUATION DATE | BOOK NUMBER |  |  |
|   |     |                   |     |     |    |         |          |            |         |                      |                      |             |  |  |
|   |     |                   |     |     |    |         |          |            |         |                      |                      |             |  |  |
|   |     |                   |     |     |    |         |          |            |         |                      |                      |             |  |  |
|   |     |                   |     |     |    |         |          |            |         |                      |                      |             |  |  |
|   |     |                   |     |     |    |         |          |            |         |                      |                      |             |  |  |
|   |     |                   |     |     |    |         |          |            |         |                      |                      |             |  |  |
|   |     |                   |     |     |    |         |          |            |         |                      |                      |             |  |  |
|   |     |                   |     |     |    |         |          |            |         |                      |                      |             |  |  |
|   |     |                   |     |     |    |         |          |            |         |                      |                      |             |  |  |
|   |     |                   |     |     |    |         |          |            |         |                      |                      |             |  |  |
|   |     |                   |     |     |    |         |          |            |         |                      |                      |             |  |  |
|   |     |                   |     |     |    |         |          |            |         |                      |                      |             |  |  |
|   |     |                   |     |     |    |         |          |            |         |                      |                      |             |  |  |
|   |     |                   |     |     |    |         |          |            |         |                      |                      |             |  |  |
|   |     |                   |     |     |    |         |          |            |         |                      |                      |             |  |  |
|   |     |                   |     |     |    |         |          |            |         |                      |                      |             |  |  |
|   |     |                   |     |     |    |         |          |            |         |                      |                      |             |  |  |
|   |     |                   |     |     |    |         |          |            |         |                      |                      |             |  |  |
|   |     |                   |     |     |    |         |          |            |         |                      |                      |             |  |  |
|   |     |                   |     |     |    |         |          |            |         |                      |                      |             |  |  |
|   |     |                   |     |     |    |         |          |            |         |                      |                      |             |  |  |
|   |     |                   |     |     |    |         |          |            |         |                      |                      |             |  |  |
|   |     |                   |     |     |    |         |          |            |         |                      |                      |             |  |  |
|   |     |                   |     |     |    |         |          |            |         |                      |                      |             |  |  |
|   |     |                   |     |     |    |         |          |            |         |                      |                      |             |  |  |
|   |     |                   |     |     |    |         |          |            |         |                      |                      |             |  |  |
|   |     |                   |     |     |    |         |          |            |         |                      |                      |             |  |  |
|   |     |                   |     |     |    |         |          |            |         |                      |                      |             |  |  |
|   |     |                   |     |     |    |         |          |            |         |                      |                      |             |  |  |
|   |     |                   |     |     |    |         |          |            |         |                      |                      |             |  |  |
|   |     |                   |     |     |    |         |          |            |         |                      |                      |             |  |  |
|   |     |                   |     |     |    |         |          |            |         |                      |                      |             |  |  |
|   |     |                   |     |     |    |         |          |            |         |                      |                      |             |  |  |
|   |     |                   |     |     |    |         |          |            |         |                      |                      |             |  |  |
|   |     |                   |     |     |    |         |          |            |         |                      |                      |             |  |  |
|   |     |                   |     |     |    |         |          |            |         |                      |                      |             |  |  |
|   |     |                   |     |     |    |         |          |            |         |                      |                      |             |  |  |
|   |     |                   |     |     |    |         |          |            |         |                      |                      |             |  |  |
|   |     |                   |     |     |    |         |          |            |         |                      |                      |             |  |  |
|   |     |                   |     |     |    |         |          |            |         |                      |                      |             |  |  |
|   |     |                   |     |     |    |         |          |            |         |                      |                      |             |  |  |
|   |     |                   |     |     |    |         |          |            |         |                      |                      |             |  |  |

FORM C 1263-17 CPS  
 (2002)



Distribution Operations

## Health, Safety and Environmental Standard

|                               |                                     |   |
|-------------------------------|-------------------------------------|---|
| Effective Date:<br>04/01/2009 | <b>Injury and Illness Reporting</b> | Standard Number:<br><b>HSE 4000.010</b> |
| Supercedes:<br>N/A            |                                     | Page 1 of 4                             |

Companies Affected:

|                                     |   |   |   |
|-------------------------------------|---|---|---|
| <input type="checkbox"/> NIPSCO     | <input checked="" type="checkbox"/> CGV | <input checked="" type="checkbox"/> COH | <input checked="" type="checkbox"/> BSG |
| <input type="checkbox"/> NIFL       | <input checked="" type="checkbox"/> CKY | <input checked="" type="checkbox"/> CPA |   |
| <input type="checkbox"/> Kokomo Gas | <input checked="" type="checkbox"/> CMD |   |   |

### 1. PURPOSE

The purpose of this procedure is to establish uniform requirements for reporting, investigating and communicating information regarding work related injuries and illnesses.

### 2. SCOPE

This procedure applies to all employees.

### 3. RESPONSIBILITIES

#### 3.1 Employee

Employees must report all injuries or illnesses to their leader/supervisor or designee as soon as possible on the day of the injury.

#### 3.2 Leader/Supervisor

Leaders/supervisors must ensure that all injuries/illnesses are recorded in the injury and illness database within 48 hours. The leader/supervisor, with the assistance of HSE, will ensure that a root cause investigation is completed for all OSHA recordables within 14 days. This review will include corrective action to prevent a recurrence.

#### 3.3 HSE Department

HSE Department designee(s) shall classify employee injuries/illnesses. Where appropriate, the HSE Department designee(s) shall assist the employee and leader/supervisor in the investigation in order to establish corrective action to prevent a recurrence of the injury/illness.

### 4. PROCEDURE

#### 4.1 Reporting Requirements

Initial Notification Requirements: Employees must report all injuries or illnesses to their leader/supervisor or designee as soon as possible on the day of the injury. If the leader/supervisor is not immediately available, the employee should report the incident to the next level of management.

|                               |                                     |   |
|-------------------------------|-------------------------------------|---|
| Effective Date:<br>04/01/2009 | <b>Injury and Illness Reporting</b> | Standard Number:<br><b>HSE 4000.010</b> |
| Supercedes:<br>N/A            |                                     | Page 2 of 4                             |

If the incident involves an employee injury, depending on the nature of the injury, the affected leader/supervisor will first assist the injured employee by securing appropriate medical attention and ensuring that the worksite has been returned to a safe condition.

All employee injuries are to be recorded in the NiSource Injury and Illness Database within 48 hours of an employee reporting an injury to a leader/supervisor or designee.

**Severe incidents** must be reported immediately to the applicable General Manager/Director/Vice-President and the HSE Department.

#### 4.2 Injury and Illness Database Reporting

Incidents involving an employee injury or illness will be reported through the corporate injury and illness reporting system using the following procedure.

From the Corporate EH&S home web page, the leader/supervisor can locate the Injury and Illness Report (Figure 1) and complete the requested information. Any field with a yellow dot is required information for the initial submittal.

**Figure 1**

**Welcome - Lotus Notes**

File Edit View Create Actions Text Help

Welcome | New Injury - Illness Report

Close Save & Close Print

**NOTE:** The **Record Injury** form (this form) is used whenever an employee is treated by a health care professional at the work-site, is provided emergency room treatment, or receives any other medical care or treatment from a licensed health care professional.

Creator's Employee ID  [Lookup Creator Info](#)

Creator's Job Classification (Title)

Creator's Phone Number

Short Description of Injury (Title)

Employee | Description | Health Care | Details | CF/CM | Notifications

**Injury or Illness Description -**

Employee's Job Assignment  What was the employee's work assignment at the time of the incident (i.e. leak repair, reading meter, leak locate, compressor overhaul, etc. ?)

Employee's Activity  What was the employee doing as the incident occurred? Describe the activity, as well as tools, material, or equipment the employee was using ...

What Happened?  Describe how the injury occurred.

What was the injury?  Tell us the part of the body that was affected and how it was affected.

Parts Affected

Nature of Injury

Cause of Injury

Harmful object or substance  What object or substance directly harmed the employee?

General Comments

Report Creator's Phone number





Distribution Operations

## Health, Safety and Environmental Standard

|                               |                                     |   |
|-------------------------------|-------------------------------------|---|
| Effective Date:<br>04/01/2009 | <b>Injury and Illness Reporting</b> | Standard Number:<br><b>HSE 4000.010</b> |
| Supercedes:<br>N/A            |                                     | Page 3 of 4                             |

Once the required information has been submitted, the system forwards the report to selected personnel and HSE.

After submittal, the creating leader/supervisor (creator) will receive confirmation that the report was submitted via email, which will include a document link. If the report is incomplete (missing data such as the number of days away from work) the leader/supervisor (creator) will receive weekly email reminders (for up to 180 days) with a document link prompting the leader/supervisor to complete the record.

The leader/supervisor opens the document link, prints the report, obtains the injured employee's signature, and files the hard copy of the report in accordance with local record keeping requirements.

The report is then assigned to an HSE Manager for recordability and/or classification according to OSHA 29 CFR 1904 recordkeeping criteria. After classification (no longer than 7 days), the report is reassigned to the creator and is forwarded electronically to Corporate EH&S for review.

The creator will receive an email notification when the incident is classified and reaches corporate review. No further action is required at this time.

**NOTE:** An Injury/Illness where the employee did not seek or request medical treatment must be entered in the Injury and Illness database as a non-medical incident.

If the employee receives medical treatment, the injured employee, or his/her leader/supervisor, must ensure that this incident is reported to the third party insurance carrier.

### 5. TRAINING

Training will be conducted by the HSE Department or designee and recorded in the Learning Management System (LMS).

### 6. RECORDS

Not Applicable.



**Distribution Operations**

**Health, Safety and Environmental Standard**

|                               |                                     |   |
|-------------------------------|-------------------------------------|---|
| Effective Date:<br>04/01/2009 | <b>Injury and Illness Reporting</b> | Standard Number:<br><b>HSE 4000.010</b> |
| Supercedes:<br>N/A            |                                     | Page 4 of 4                             |

**7. DEFINITIONS**

**Severe Incident:** An incident in relation to NiSource businesses in which:

- a. any person (employee, contractor, member of the public, etc.) is seriously injured or killed;
- b. the potential for serious injury or death may occur as a result of the incident; substantial property damage has occurred; or
- c. the potential to cause a significant environmental impact exists as a result of the incident.

**8. REFERENCES**

OSHA 29 CFR 1904



Distribution Operations

Health, Safety and Environmental Standard

|                               |                               |   |
|-------------------------------|-------------------------------|---|
| Effective Date:<br>10/01/2011 | <b>First Aid Requirements</b> | Standard Number:<br><b>HSE 4000.020</b> |
| Supersedes:<br>04/01/2009     |                               | Page 1 of 4                             |

Companies Affected:

|                                 |   |   |
|---------------------------------|---|---|
| <input type="checkbox"/> NIPSCO | <input checked="" type="checkbox"/> CGV | <input checked="" type="checkbox"/> CMD |
|                                 | <input checked="" type="checkbox"/> CKY | <input checked="" type="checkbox"/> COH |
|                                 | <input checked="" type="checkbox"/> CMA | <input checked="" type="checkbox"/> CPA |

**1. PURPOSE**

This document is to establish first aid training requirements for all of Distribution Operations employees and outline the basic content and inspection of first aid kits located on Company property, in Company vehicles, or on Company equipment for the first aid treatment of employees.

**2. SCOPE**

This procedure is applicable to first aid trained Distribution Operations personnel.

**3. RESPONSIBILITIES**

**3.1 Employee**

Employees are required to know the location of the nearest first aid kit in the workplace. An employee shall inspect first aid kit contents and report any used items to the leader/supervisor or designee to insure the replacement of that item.

**3.2 Leader/Supervisor**

Each Leader/Supervisor shall ensure that at least one employee in each work crew is trained in first aid. The Leader/Supervisor has the responsibility of ensuring monthly inspection and maintenance of first aid kits located at their workplaces or areas of responsibility is performed and that adequate supplies are maintained for treatment of injuries to employees.

**3.3 HSE Department**

The Health, Safety, and Environmental (HSE) Department shall review and approve any items contained in first aid kits. The HSE Department will review and approve vendors selected to perform any first aid training. The HSE Department shall also provide technical assistance.

**4. PROCEDURE**

**4.1 First Aid Kit Inspection**

Employees shall inspect first-aid kits to ensure the following.

*This document is considered CONTROLLED only when viewed electronically on the Company's intranet. Printed or other electronic copies may not be current, and the intranet version should be used to verify.*



**Distribution Operations**

**Health, Safety and Environmental Standard**

|                               |                               |   |
|-------------------------------|-------------------------------|---|
| Effective Date:<br>10/01/2011 | <b>First Aid Requirements</b> | Standard Number:<br><b>HSE 4000.020</b> |
| Supersedes:<br>04/01/2009     |                               | Page 2 of 4                             |

- a. Review the conditions of the contents.
- b. Inspect the condition of the container.
- c. Ensure a required contents label is on the inside cover.
- d. Immediately inform a leader/supervisor or designee if any of the kits contents are used, damaged, or of questionable integrity and ensure items are replaced.
- e. Inspection Frequency: First-aid kits shall be inspected monthly when in use.

**4.2 First Aid Supplies**

The HSE Department shall approve first aid supplies used in first aid kits. Contact the appropriate HSE Coordinator for supplier information.

**5. TRAINING**

First aid training can be conducted by certified instructor(s), selected by the HSE Department. First aid training can be conducted by qualified outside organizations such as the Red Cross, National Safety Council and private institutions such as Medic First Aid.

Training for the OSHA Bloodborne Pathogen guideline requirements in emergency first aid will be given to all employees trained in first aid and repeated annually.

Employees are required to attend first aid training at intervals not to exceed the certification agency's recommended timeframe.

**6. RECORDS**

**6.1 Record Retention**

The First-Aid Kit Label (Exhibit A) shall be kept for the existing year until the first inspection of a new year has been completed and recorded on a new First-Aid Kit Label.

**6.2 Record Location**

First aid and Bloodborne Pathogen training will be recorded in NiSource's Learning Management System.

**6.3 Forms**

First aid kit inspection shall be recorded on the First Aid Kit Label (Form HSE 4000.020-01).



**Distribution Operations**

**Health, Safety and Environmental Standard**

|                               |                               |   |
|-------------------------------|-------------------------------|---|
| Effective Date:<br>10/01/2011 | <b>First Aid Requirements</b> | Standard Number:<br><b>HSE 4000.020</b> |
| Supersedes:<br>04/01/2009     |                               | Page 3 of 4                             |

**7. REFERENCES**

OSHA 1910.151 (b)



Distribution Operations

Health, Safety and Environmental Standard

|                               |                               |   |
|-------------------------------|-------------------------------|---|
| Effective Date:<br>10/01/2011 | <b>First Aid Requirements</b> | Standard Number:<br><b>HSE 4000.020</b> |
| Supersedes:<br>04/01/2009     |                               | Page 4 of 4                             |

**EXHIBIT A**

**FIRST AID KIT INVENTORY**

**UNIT FIRST AID KIT LOCATION** \_\_\_\_\_

THE FOLLOWING ITEMS ARE TO BE CONTAINED IN THIS FIRST AID KIT.

IN REORDERING ITEMS, REFER TO COMPANY POLICY.

| <u>Item</u>                               | <u>Quantity</u> |
|---|-----------------|
| 4" Offset Bandage                         | 1               |
| 2" Offset Bandage Compress                | 1               |
| 1" Adhesive Bandage                       | 1               |
| 42" Triangular Bandage                    | 1               |
| Eye Dressing Packet with Eyewash Solution | 1               |
| Burn Jel, 1/8 oz, packets                 | 1               |
| PVP Iodine Wipes                          | 2 boxes         |
| Sting Kill Wipes                          | 1               |
| Hydrocortisone 1/32 oz packets            | 1               |
| Wire Splint                               | 1               |
| Gloves Vinyl                              | 1 pr            |
| Anti-Microbial Wipes                      | 1               |
| Biohazard Bag with Scraper                | 1               |
| Mouth Protection for CPR Administration   | 1               |

LEADER/SUPERVISOR OR DESIGNEE

DATE

**J F M A M J J A S O N D** YEAR \_\_\_\_\_  
 (Strike through and initial month following inspection)



Distribution Operations

## Health, Safety and Environmental Standard

|                               |                                     |   |
|-------------------------------|-------------------------------------|---|
| Effective Date:<br>04/01/2009 | <b>Hearing Conservation Program</b> | Standard Number:<br><b>HSE 4000.030</b> |
| Supercedes:<br>N/A            |                                     | Page 1 of 7                             |

Companies Affected:

|                                     |   |   |   |
|-------------------------------------|---|---|---|
| <input type="checkbox"/> NIPSCO     | <input checked="" type="checkbox"/> CGV | <input checked="" type="checkbox"/> COH | <input checked="" type="checkbox"/> BSG |
| <input type="checkbox"/> NIFL       | <input checked="" type="checkbox"/> CKY | <input checked="" type="checkbox"/> CPA |   |
| <input type="checkbox"/> Kokomo Gas | <input checked="" type="checkbox"/> CMD |   |   |

### 1. PURPOSE

The purpose of this program is to protect NiSource employees with significant occupational noise exposures from suffering material hearing impairment because of these exposures. This protection is accomplished through noise monitoring, use of feasible administrative and engineering controls, audiometric testing, use of hearing protection, training and recordkeeping.

### 2. SCOPE

The hearing conservation program applies to all NiSource employees whose 8-Hour **Time Weighted Average (TWA)** exposure to noise exceeds 85 **dba** (referred to as the **Action Level**).

### 3. RESPONSIBILITIES

#### 3.1 Employees and Leaders/Supervisors

Employees and leaders/supervisors designated for inclusion in the Hearing Conservation Program shall meet the following.

- a. Use and maintain hearing protection devices assigned to them, as required.
- b. Participate in training, monitoring and audiometric testing programs, as directed.

#### 3.2 Local Management

Local Management, for employees whose exposure to noise exceeds the Action Level, shall provide the following.

- a. Implement an effective Hearing Conservation Program.
- b. Establish and maintain an Audiometric Testing Program.
- c. Provide a variety of suitable hearing protection devices for employee use.
- d. Direct signs to be posted in specific "*Hearing Protection Required*" and "*High Noise – Restricted Access*" areas within their facilities, as required.



**Distribution Operations**

**Health, Safety and Environmental Standard**

|                               |                                     |   |
|-------------------------------|-------------------------------------|---|
| Effective Date:<br>04/01/2009 | <b>Hearing Conservation Program</b> | Standard Number:<br><b>HSE 4000.030</b> |
| Supercedes:<br>N/A            |                                     | Page 2 of 7                             |

- e. Maintain a list of employees impacted by this program.

Note: For those facilities determined not to have noise level exceeding the OSHA requirements, facility data is not required.

**3.3 HSE Coordinators**

Local Health, Safety and Environmental (HSE) Coordinators shall fulfill the role of Hearing Conservation Program Administrator and facilitate compliance with all aspects of this program for specific locations. The responsibilities of the Program Administrator are the following.

- a. Determining and scheduling area noise surveys and/or personal dosimetry.
- b. Selecting, ordering and distributing hearing protection devices (HPD).
- c. Providing and scheduling employee training.
- d. Scheduling audiometric testing for Hearing Conservation Program participants.
- e. Notifying employees of monitoring and testing results.
- f. Recording OSHA recordable hearing shifts into the Injury and Illness database.

**4. PROCEDURE**

**4.1 Audiometric Testing**

**4.1.1 Frequency**

For new employees who accept positions where exposure is at or above the OSHA action level, baseline audiograms shall be performed within the first six months of hiring. All other individuals included in the hearing conservation program will receive audiometric tests on an annual basis.

**4.1.2 Testing Facility**

A licensed, certified, or qualified testing firm will perform audiometric testing. On an annual basis, the chosen audiometric testing firm shall submit a written certification of qualification.





**Distribution Operations**

## Health, Safety and Environmental Standard

|                               |                                     |   |
|-------------------------------|-------------------------------------|---|
| Effective Date:<br>04/01/2009 | <b>Hearing Conservation Program</b> | Standard Number:<br><b>HSE 4000.030</b> |
| Supercedes:<br>N/A            |                                     | Page 3 of 7                             |

### 4.1.3 Audiometric Results

The results of the audiometric testing shall be reviewed by a certified audiologist or physician to determine if the employee has suffered a Standard Threshold Shift (STS). The results of the audiogram shall be maintained in the employees' medical file.

### 4.1.4 STS Reporting

Standard Threshold Shifts greater than 10 dBA are to be recorded on the company's Injury and Illness database. An employee may be retested within thirty (30) days of the audiometric exam for verification that a shift has occurred prior to any entry into the database.

## 4.2 Noise Exposure Determination

### 4.2.1 Noise Surveys

Personnel specifically trained in sound monitoring techniques shall conduct noise surveys to determine which areas, tools, equipment and/or jobs have the potential to expose employees to an eight-hour time weighted average noise level of 85 dBA or greater. Surveys shall be performed at least once every five (5) years or when significant modifications of machinery or processes result in increased noise levels. Representative area monitoring shall be used to identify high noise areas and tasks at the facility.

### 4.2.2 Personal Dosimetry

Where circumstances make area monitoring inappropriate, or when noise levels measured and occupation patterns indicate the potential for overexposure to noise exists, representative personal sampling shall be conducted with a dosimeter. Personal dosimetry shall be performed by an independent third party, who is trained in the calibration and use of dosimeters, the performance of personal dosimetry and the interpretation of personal monitoring results.

### 4.2.3 Employee Notification

Employees exposed at or above the action level shall be notified of the results of personal noise monitoring.

### 4.2.4 Summary of Previous Noise Monitoring

A summary of results from area and personal monitoring performed for the NiSource affiliate shall be documented. (Note: For those facilities determined



Distribution Operations

## Health, Safety and Environmental Standard

|                               |                                     |   |
|-------------------------------|-------------------------------------|---|
| Effective Date:<br>04/01/2009 | <b>Hearing Conservation Program</b> | Standard Number:<br><b>HSE 4000.030</b> |
| Supercedes:<br>N/A            |                                     | Page 4 of 7                             |

not to have noise level exceeding the OSHA requirements, facility data is not required.)

General locations and operations or activities that have the potential to generate exposures above the action level are listed in Exhibit A. This listing may not be all inclusive: when there is a concern that an unlisted operation may lead to exposures above the action level, the employee and/or the leader/supervisor should request that a noise survey be conducted. Employees have the option of wearing hearing protection until the sound survey is conducted and should be encouraged to do so.

### 4.3 Designation and Signs

Areas within any facility identified to have noise levels above 85 dBA shall be designated as "*Hearing Protection Required*" areas. Signs shall be posted to indicate that all personnel working in these areas are required to wear hearing protection devices while in these areas.

Areas within any facility identified to have noise levels above 90 dBA that cannot be feasibly reduced by **engineering controls** shall be designated as "*High Noise - Restricted Access*" areas. Signs shall be posted to indicate that all personnel working in these areas are required to wear hearing protection devices while in these areas. Additionally signs shall be posted to indicate the maximum amount of time to be spent in this area. (These maximum times shall be determined from Table G-16 of 29 CFR 1910.95.)

### 4.4 Hearing Protection Equipment

#### 4.4.1 General

When working in designated "*Hearing Protection Required*" areas or performing tasks where the noise exposure could exceed the action level, employees shall be provided with and shall be required to wear hearing protective equipment.

#### 4.4.2 Selection

Employees shall be given the opportunity to select hearing protection devices from a variety of suitable protectors approved for use. The designated Program Administrator will evaluate the **NIOSH** NRR rating of all selected hearing protective equipment to ensure adequate attenuation for site-specific noise environments.



Distribution Operations

## Health, Safety and Environmental Standard

|                               |                                     |   |
|-------------------------------|-------------------------------------|---|
| Effective Date:<br>04/01/2009 | <b>Hearing Conservation Program</b> | Standard Number:<br><b>HSE 4000.030</b> |
| Supersedes:<br>N/A            |                                     | Page 5 of 7                             |

### 4.4.3 Use

Employees shall use and leaders/supervisors shall require and enforce the use of hearing protection devices by all employees working in designated areas, or utilizing tools or equipment that have been shown to create the potential for overexposure to noise.

### 4.5 Engineering and Administrative Controls

When employees are exposed to sound levels exceeding 90 dBA for an 8-Hour TWA (or the levels listed in Table G-16 of 29 CFR 1910.95) feasible administrative or engineering controls shall be utilized to reduce employee exposure. If these controls are not feasible, or if these controls fail to reduce noise levels below 90 dBA for an 8-Hour TWA (or the levels of Table G-16), **personal protective equipment (PPE)** shall be provided and utilized to bring sound levels within the levels of Table G-16.

## 5. TRAINING

Training shall be provided annually to all employees exposed to noise at or above the action level. This training shall include, but is not limited to, the following items.

- a. Effects of noise on hearing.
- b. Purpose of hearing protectors, advantages, disadvantages, proper fitting and use.
- c. Purpose of audiometric testing.
- d. Identification of high noise areas and tasks.
- e. Requirements of this program.

Training shall be scheduled by the designated Program Administrator and shall be recorded in the NiSource Learning Management System (LMS).

## 6. RECORDS

The designated Program Administrator shall maintain employee exposure assessments, training records and audiometric testing results.

Noise exposure measurement records shall be maintained for at least three (3) years or until the data becomes obsolete. Obsolescence shall be established by subsequent noise exposure measurements, elimination of the facility or equipment associated with the measurements, or changes in work duties or procedures.

Records of personal dosimetry measurements shall be maintained for the duration of the



Distribution Operations

## Health, Safety and Environmental Standard

|                               |                                     |   |
|-------------------------------|-------------------------------------|---|
| Effective Date:<br>04/01/2009 | <b>Hearing Conservation Program</b> | Standard Number:<br><b>HSE 4000.030</b> |
| Supercedes:<br>N/A            |                                     | Page 6 of 7                             |

affected employees' employment.

Audiometric test records shall be retained for the duration of the affected employee's employment.

All records required by this program or by regulation shall be furnished to employees, former employees, or representatives designated by individual employees or their representative upon request.

### 7. DEFINITIONS

**Action Level** - Defined by OSHA as an eight-hour time-weighted average exposure of 85 dBA.

**Administrative Controls** – Control of noise exposure through job rotation, posting of signs and stay times in high noise areas.

**dBA** – The measurement of sound using decibels on the “A” weighted scale.

**Engineering Controls** – The control of noise through the use of acoustical insulation, enclosure of equipment and the reduction of vibration.

**NIOSH** – National Institute of Occupational Safety and Health

**Personal Protective Equipment (PPE)** – Devices such as disposable and custom fitting earplugs and earmuff style hearing protectors.

**TWA** – Time Weighted Average, exposure to noise, typically based on an 8-Hour exposure.

### 8. REFERENCES

29 CFR 1910.95 Occupational Noise Exposure

29 CFR 1926.52 Occupational Noise Exposure



**Distribution Operations**

**Health, Safety and Environmental Standard**

|                               |                                     |   |
|-------------------------------|-------------------------------------|---|
| Effective Date:<br>04/01/2009 | <b>Hearing Conservation Program</b> | Standard Number:<br><b>HSE 4000.030</b> |
| Supercedes:<br>N/A            |                                     | Page 7 of 7                             |

**EXHIBIT A**

**Examples of Work activities that may exceed the OSHA Action Level**

NiSource affiliate site locations which may exceed the action level:

Compressor Stations  
M&R Stations  
Regulator buildings  
Generating Stations

Activities which may exceed the action level:

Blowdown of Compressor Stations  
Blowdown of M&R Stations  
Operating a “blowdown” or relief valve under high pressure  
Purging bar holes or piping

NOTE: Personal dosimetry monitoring as of July 1, 2007 indicates that in NiSource Distribution Operations affiliates, the only activity monitored which may exceed the OSHA Action Level is the operation of a jackhammer or other pavement breaking equipment for more than than 5 hours over an 8 hour workday. Sampling of job classification such as “Plant”, “Service”, “Construction and Maintenance” and “GM and T” indicate that no action levels are exceeded.



Distribution Operations

Health, Safety and Environmental Standard

|                               |  |   |
|-------------------------------|--|---|
| Effective Date:<br>04/01/2009 | <b>Hazardous Communications<br/>(HAZCOM)</b> | Standard Number:<br><b>HSE 4000.040</b> |
| Supercedes:<br>N/A            |  | Page 1 of 4                             |

Companies Affected:

|                                     |   |   |   |
|-------------------------------------|---|---|---|
| <input type="checkbox"/> NIPSCO     | <input checked="" type="checkbox"/> CGV | <input checked="" type="checkbox"/> COH | <input checked="" type="checkbox"/> BSG |
| <input type="checkbox"/> NIFL       | <input checked="" type="checkbox"/> CKY | <input checked="" type="checkbox"/> CPA |   |
| <input type="checkbox"/> Kokomo Gas | <input checked="" type="checkbox"/> CMD |   |   |

**1. PURPOSE**

This chemical hazard communication procedure serves to ensure that employees are aware that they may be exposed to **hazardous chemicals** in the workplace, that they know how to read and use information on container labels and material safety data sheets (MSDS), and that they are following protective measures in the event of exposure.

**2. SCOPE**

The procedure applies to all distribution operations work locations where employees may be exposed to hazardous chemicals under normal working conditions, performing non-routine tasks or during an emergency situation.

**3. RESPONSIBILITIES**

**3.1 Local Facility Management**

Local facility management shall ensure that the delivery of any hazardous chemical not previously used or warehoused by any NiSource affiliate company is accompanied by a MSDS from the supplier/distributor for that product. If an MSDS is not received with a product that is not already in the NiSource chemical inventory, that product shall not be used until a MSDS can be obtained.

Local facility management shall coordinate a chemical inventory of their facilities. The inventory shall include the product name, manufacturer, product number (when appropriate) and the Universal Product Code (UPC), when possible, for any hazardous chemical stored at the facility and/or used by the facility employees.

**3.2 Leader/Supervisor**

The local leader/supervisor shall conduct the following tasks.

- a. Ensure an inventory of the hazardous chemicals that are stored and/or used by employees at that facility is conducted annually.
- b. Ensure all hazardous chemicals in their respective work environments are properly labeled.
- c. Ensure all employees in their work area potentially exposed to hazardous chemical are trained.
- d. MSDS's for hazardous chemicals are readily available.



**Distribution Operations**

## Health, Safety and Environmental Standard

|                               |  |   |
|-------------------------------|--|---|
| Effective Date:<br>04/01/2009 | <b>Hazardous Communications<br/>(HAZCOM)</b> | Standard Number:<br><b>HSE 4000.040</b> |
| Supercedes:<br>N/A            |  | Page 2 of 4                             |

### 3.3 Employees

Employees are accountable for the following.

- a. Understanding the meaning of the labels on hazardous chemicals and knowing any measures needed to ensure safe work practices.
- b. Using the correct personal protective equipment when necessary.
- c. Understanding how to request a MSDS.
- d. Reporting any unlabeled container that contains a hazardous chemical.

## 4. PROCEDURE

### 4.1 Material Safety Data Sheet (MSDS) Management

MSDS's of previously identified hazardous chemicals used throughout NiSource can be obtained by accessing the "MSDS" link through the Corporate EH&S home page. This will link to the NiSource chemical inventory database hosted by Dolphin Software.

A local facility may request to their local HS&E Coordinator that a product used in another NiSource facility be assigned to their location by providing the Coordinator with the product name, the manufacturer and existing product number.

A local facility may also request to add a product to the NiSource database if a purchased product has not been previously used by NiSource. Information provided to the HS&E Coordinator shall include the product name, the manufacturer and MSDS as provided by the supplier/distributor.

In a medical emergency situation, when a MSDS is not readily available, any NiSource affiliate employee may call the 24/7 Dolphin Software telephone (877.279.0441) and request an MSDS via fax.

### 4.2 Labeling Systems

A hazard communication labeling system shall consist of the manufacturer's label, the "NFPA" or the "HMIS" system. Labels shall list the chemical identity and the appropriate hazard warnings.

Unlabeled chemicals received from a supplier/distributor must be rejected by a facility and returned to the vendor for appropriate labeling.

Portable or secondary containers shall display a legible manufacturer's label or the hazard communication label used locally.



**Distribution Operations**

## Health, Safety and Environmental Standard

|                               |  |   |
|-------------------------------|--|---|
| Effective Date:<br>04/01/2009 | <b>Hazardous Communications<br/>(HAZCOM)</b> | Standard Number:<br><b>HSE 4000.040</b> |
| Supersedes:<br>N/A            |  | Page 3 of 4                             |

DOT hazardous material warning labels that are affixed to packages shall not be removed and shall be maintained in a legible condition until the hazard is no longer present.

### 4.3 Program Review

The HS&E Coordinator shall review the effectiveness of the hazardous communication program periodically. This review shall ensure that all employees are trained according to this procedure and the hazardous communication standard, that the chemical inventories accurately reflect the chemicals in storage and/or in use, that employees understand how to access MSDS's, and that containers are appropriately labeled. This program review shall be documented in the work management system.

### 4.4 Contractors

It shall be the responsibility of the local contractor management liaison to provide contractors with the following information.

- a. The availability of the MSDS database and local labeling system of chemicals contract employees may be exposed to while performing tasks for the NiSource affiliate.
- b. Any special precautionary measures the contractor's employees should take to protect themselves during normal operations and during foreseeable emergencies.
- c. Securing and communicating the appropriate precautions to be taken by facility employees to avoid harmful exposures to chemicals brought into the work area by contractors.

## 5. TRAINING

All NiSource employees must receive annual Hazard Communication training. Additionally, every employee who works with, or is potentially exposed to, hazardous chemicals shall receive training at the time of their initial assignment, and whenever a new or non-routine physical or health hazard for which the employee has never received training is introduced into their work environment.

Training shall include the following.

- a. A summary of the Hazard Communications standard and the hazard communication program.
- b. Chemical and physical properties of hazardous materials.
- c. Physical hazards of chemicals.





**Distribution Operations**

**Health, Safety and Environmental Standard**

|                               |  |   |
|-------------------------------|--|---|
| Effective Date:<br>04/01/2009 | <b>Hazardous Communications<br/>(HAZCOM)</b> | Standard Number:<br><b>HSE 4000.040</b> |
| Supersedes:<br>N/A            |  | Page 4 of 4                             |

- d. Health hazards, including signs and symptoms of chemical exposure and any medical conditions known to be aggravated by exposure to the chemical.
- e. Measures employees can take to protect themselves (e.g., work procedures, work practices, emergency procedures and personal protective equipment).
- f. How to access the NiSource MSDS database.
- g. How to read and interpret the information on both labels and a MSDS.

Periodic retraining is required when an employee is observed not to demonstrate an adequate understanding and implementation of safe work procedures as they relate to chemical hazard communications.

**6. RECORDS**

Employee hazard communication training shall be documented using NiSource's Learning Management System (LMS).

**7. DEFINITIONS**

**Hazardous chemical** - Any chemical this is a **physical** or **health** hazard.

**Health hazard** - A chemical for which there is statically significant evidence that an acute or chronic health effect may occur to an exposed employee.

**Physical hazard** - A chemical that is combustible liquid, a compressed gas, explosive, flammable, an organic peroxide, an oxidizer, pyrophoric, unstable or water reactive.

**8. REFERENCES**

29 CFR 1910.1200, Hazard Communication



## Health, Safety and Environmental Standard

### Distribution Operations

|                               |   |  |
|-------------------------------|---|--|
| Effective Date:<br>03/01/1979 | <b>Daily Pre-Operational Checklist<br/>(Lift Truck)</b> | Standard Number:<br><b>HSE 4000.060(CG)</b><br>P&P 405-6 |
| Supersedes:<br>N/A            |   | Page 1 of 2  |

Companies Affected:

|                                     |   |   |
|-------------------------------------|---|---|
| <input type="checkbox"/> NIPSCO     | <input checked="" type="checkbox"/> CGV | <input checked="" type="checkbox"/> CMD |
| <input type="checkbox"/> NIFL       | <input checked="" type="checkbox"/> CKY | <input checked="" type="checkbox"/> COH |
| <input type="checkbox"/> Kokomo Gas | <input type="checkbox"/> CMA            | <input checked="" type="checkbox"/> CPA |

**REFERENCE**    None

The Daily Pre-Operational Checklist, Form C 1559 (Exhibit A), shall be completed prior to placing into service any powered industrial truck (Forklift). If the daily examination shows any condition adversely affecting the safety of the vehicle, it shall not be placed in service. Defects, when found, shall be immediately reported and corrected.

The Daily Pre-Operational Checklist should be retained at the work location for a period of ninety (90) days for the development of maintenance history for each vehicle.

This procedure is in conformance with Federal standards (Ref. OSHA 1910.178 (g)(7)).

*This document is considered CONTROLLED only when viewed electronically on the Company's intranet. Printed or other electronic copies may not be current, and the intranet version should be used to verify.*



Distribution Operations

Health, Safety and Environmental Standard

|                               |   |  |
|-------------------------------|---|--|
| Effective Date:<br>03/01/1979 | <b>Daily Pre-Operational Checklist<br/>(Lift Truck)</b> | Standard Number:<br><b>HSE 4000.060(CG)</b><br>P&P 405-6 |
| Supersedes:<br>N/A            |   | Page 2 of 2  |

EXHIBIT A

FORM C (ER) 1559 CSD

○

COLUMBIA GAS DISTRIBUTION COMPANIES  
**DAILY PRE-OPERATIONAL CHECKLIST  
(LIFT TRUCK)**

TRUCK NO. 0113                      DATE 3-1-79

INSPECTED BY RCK                      SUPERVISOR \_\_\_\_\_

HOUR METER READING:  
START 077 FINISH 086 HOURS USED 9

CHECK APPROPRIATE BOX:  (OPERATIONAL)  
 (NEEDS ATTENTION. NOTIFY SUPERVISOR)  (DO NOT OPERATE)

| VISUAL CHECKS  | OK | NA | NG | OPERATIONAL   | OK | NA | NG |
|----------------|----|----|----|---------------|----|----|----|
| ENGINE OIL     | X  |    |    | HORN          | X  |    |    |
| COOLANT LEVEL  | X  |    |    | STEERING      | X  |    |    |
| FUEL           | X  |    |    | SERVICE BRAKE | X  |    |    |
| TIRES          | X  |    |    | PARKING BRAKE | X  |    |    |
| LIGHTS         | X  |    |    | HYDRAULIC     | X  |    |    |
| HOUR METER     | X  |    |    | EXHAUST       | X  |    |    |
| GAUGES         | X  |    |    | ENGINE        | X  |    |    |
| BATTERY(S)     |    | X  |    | OTHER         |    |    |    |
| OBVIOUS DAMAGE | X  |    |    |               |    |    |    |

REMARKS: *(Explain All Items Needing Attention or Repair)*

BATTERY TERMINALS CORRODED

\_\_\_\_\_

\_\_\_\_\_



**Health, Safety and Environmental Standard**

**Distribution Operations**

|                               |                             |  |
|-------------------------------|-----------------------------|--|
| Effective Date:<br>03/01/1979 | <b>"Do Not Operate" Tag</b> | Standard Number:<br><b>HSE 4000.062(CG)</b><br>P&P 405-7 |
| Supersedes:<br>N/A            |                             | Page 1 of 2  |

Companies Affected:

|                                     |   |   |
|-------------------------------------|---|---|
| <input type="checkbox"/> NIPSCO     | <input checked="" type="checkbox"/> CGV | <input checked="" type="checkbox"/> CMD |
| <input type="checkbox"/> NIFL       | <input checked="" type="checkbox"/> CKY | <input checked="" type="checkbox"/> COH |
| <input type="checkbox"/> Kokomo Gas | <input type="checkbox"/> CMA            | <input checked="" type="checkbox"/> CPA |

**REFERENCE**    None

The "Do Not Operate" tag, Form C 1592 (Exhibit A), is attached to tools, ladders, valves, switches and other equipment in need of repair as notification that the particular piece of equipment is therefore unsafe to use.

This procedure is in conformance with Federal standards (Ref. OSHA 1910.145 (f)).

*This document is considered CONTROLLED only when viewed electronically on the Company's intranet. Printed or other electronic copies may not be current, and the intranet version should be used to verify.*

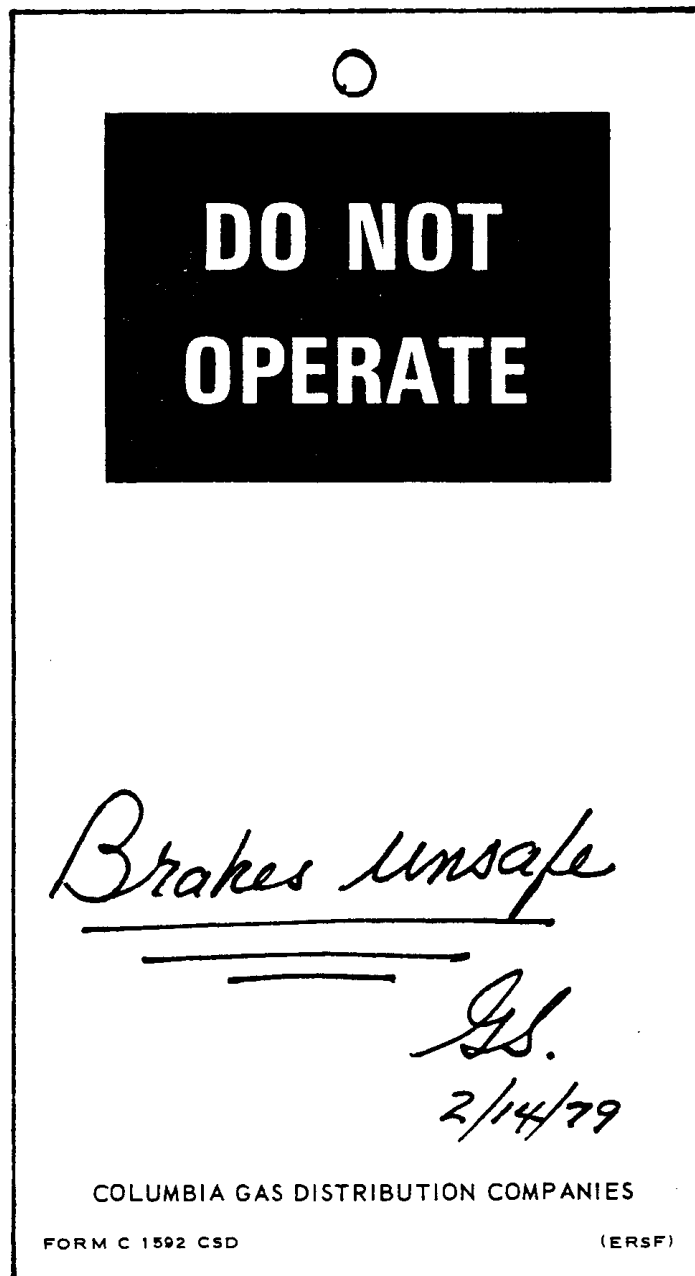


Distribution Operations

Health, Safety and Environmental Standard

|                               |                             |  |
|-------------------------------|-----------------------------|--|
| Effective Date:<br>03/01/1979 | <b>"Do Not Operate" Tag</b> | Standard Number:<br><b>HSE 4000.062(CG)</b><br>P&P 405-7 |
| Supersedes:<br>N/A            |                             | Page 2 of 2  |

EXHIBIT A





**Health, Safety and Environmental Standard**

**Distribution Operations**

|                               |   |  |
|-------------------------------|---|--|
| Effective Date:<br>01/09/1991 | <b>Propane Properties and Safety Considerations</b> | Standard Number:<br><b>HSE 4000.070(CG)</b><br>P&P 415-1 |
| Supersedes:<br>N/A            |   | Page 1 of 12   |

Companies Affected:

|                                     |   |   |
|-------------------------------------|---|---|
| <input type="checkbox"/> NIPSCO     | <input checked="" type="checkbox"/> CGV | <input checked="" type="checkbox"/> CMD |
| <input type="checkbox"/> NIFL       | <input checked="" type="checkbox"/> CKY | <input checked="" type="checkbox"/> COH |
| <input type="checkbox"/> Kokomo Gas | <input type="checkbox"/> CMA            | <input checked="" type="checkbox"/> CPA |

**REFERENCE** NFPA 54 – NFPA 58 – NFPA 59

**1. PROPERTIES OF PROPANE**

Under normal Atmospheric pressures and temperatures, propane exists as a gas; however, it can readily be liquefied by increasing the pressure and/or decreasing the temperature. In its gaseous state, propane occupies 230 to 275 times as much space as it does in the liquid state. Exhibit A provides additional information regarding the approximate properties of propane gas. Contact Human Resources – Safety and Training if a specific supplier's Material Safety Data Sheet (MSDS) is desired.

Propane which CDC purchases is odorized. Employees working with propane should become familiar with its unique odor.

Propane, although non-toxic like natural gas, can displace oxygen, thereby creating a deficiency of oxygen which may result in asphyxiation.

Propane disperses in air but not as rapidly as natural gas. Propane is heavier than air and tends to settle in low spot, such as basements, crawl spaces, excavations, and other depressions.

Propane will burn within the approximate limits of 2% to 10% gas in air. Within these limits it is easily ignited by a spark, flame or other ignition source.

**2. POTENTIAL HAZARDS ASSOCIATED WITH PROPANE**

Propane can be potentially hazardous and may result in:

- a. Fire - due to propane burning uncontrollably;
- b. Explosion - due to a confined accumulation of propane being ignited;
- c. Asphyxiation - due to propane displacing the oxygen in the immediate area;
- d. Poisoning - due to carbon monoxide accumulation resulting from incomplete combustion of propane;
- e. Freezing - due to liquid propane coming into contact with exposed parts of the body.

*This document is considered CONTROLLED only when viewed electronically on the Company's intranet. Printed or other electronic copies may not be current, and the intranet version should be used to verify.*



Distribution Operations

Health, Safety and Environmental Standard

|                               |   |  |
|-------------------------------|---|--|
| Effective Date:<br>01/09/1991 | <b>Propane Properties and Safety Considerations</b> | Standard Number:<br><b>HSE 4000.070(CG)</b><br>P&P 415-1 |
| Supersedes:<br>N/A            |   | Page 2 of 12   |

**3. SAFETY PRACTICES REGARDING PROPANE**

**3.1 Fire Prevention**

Prior to working on bulk storage tanks, mains and service lines containing propane the following fire prevention steps shall be considered:

- a. control valve(s) location and accessibility.
- b. accessibility of fire fighting equipment.
- c. elimination of unnecessary sources of ignition from the job site. Sources of ignition can be running engines, electric motors, lanterns, flares, lighted cigarettes, welding/cutting torches and matches/lighters.
- d. purging or ventilating the job site.
- e. installing bonding clamps prior to separating active or inactive metallic facilities.
- f. attachment of bond wire between truck and tank before filling tank.
- g. use of hoses and equipment rated for liquefied petroleum (LP) gases. LP gases will deteriorate petroleum and rubber based products.

**3.2 Propane Gas Fires**

In the event of a propane gas fire, steps shall be taken to protect life and prevent personal injury and property damage.

Propane gas burns hotter than natural gas and is harder to extinguish. The best method of controlling a propane fire is to shut off the fuel supply before attempting to extinguish the flames. Stopping the flow of propane shall be the first consideration.

Should a delivery vehicle be involved, consult the driver for the supply valve location. If a propane tank facility is involved, the operating personnel should evaluate whether the tank shut off is accessible and capable of being shut off. If a propane distribution main is involved, operating personnel shall close the nearest isolation valve.

If the only valve to shut off the fuel supply is within the fire, shut-off should only be attempted by fire fighters in fire-resistant clothing within a water fog stream. Caution shall be exercised to avoid flashbacks or trapping the fire fighters in the flames.

The controlled burning of propane gas to consume the leaking propane, which cannot be shut off, is a commonly accepted fire-fighting practice. The propane tank(s) and related piping shall be sprayed with water to keep the metal cool thus avoiding tank failure.



Distribution Operations

Health, Safety and Environmental Standard

|                               |   |  |
|-------------------------------|---|--|
| Effective Date:<br>01/09/1991 | <b>Propane Properties and Safety Considerations</b> | Standard Number:<br><b>HSE 4000.070(CG)</b><br>P&P 415-1 |
| Supersedes:<br>N/A            |   | Page 3 of 12   |

When sufficient water is not available to keep the tank cool, danger exists of the tank rupturing. When the tanks are within the fire, an increase in the fire noise level is an alert warning prior to a tank rupture. Such an alert warning shall cause withdrawal to a safe area.

Any approach and withdrawal from a tank should be from the sides, since the tank ends are more susceptible to rupture.

**3.3 Leakage Without Fire**

The best method of controlling a propane leak is to shut off the fuel supply. Small lines, such as copper tubing, can be flattened to stop the flow of gas.

Should a delivery vehicle be involved, consult the driver for the supply valve location. If a propane tank facility is involved, the operating personnel should evaluate whether the tank shut off is accessible and capable of being shut off. If a propane distribution main is involved, operating personnel shall close the nearest isolation valve.

If the flow of propane cannot be stopped, the propane vapor cloud shall be dispersed. Propane vapor clouds present a greater danger than burning propane. Water spray is effective in dispersing a propane vapor cloud. If available, it should be used immediately. The water spray should be directed across the apparent vapor paths, thereby dispersing the vapor to a safe location. Those handling the water hose should avoid entering the vapor cloud and should keep low behind the spray for protection against an accidental ignition of the cloud.

In some instances of propane leakage from a source without a fire, it may be desirable to move the tank to some remote area, such as a blocked-off isolated roadway or open field, where it can safely be allowed to leak and dispense. Tanks shall only be moved in an upright position. Never drag the tank in a manner which could damage valves and piping. Any attempt to upright a tank for moving should be done carefully to avoid valve and piping damage.

If it is impractical to control the fuel flow, consider the advisability of gas ignition to eliminate the spread of the vapor cloud. In many instances, serious hazards can be eliminated if vapors are ignited and leakage allowed to burn under controlled conditions. Such conditions shall involve application of sufficient water to the tank's shell and any exposed piping.

Should ignition be attempted it shall be from a safe distance, upwind and near point of leakage and then only after determining that all personnel are in the clear.

**3.4 Exposure of LP Tanks to Adjacent Fire**

In the event LP storage tanks are subjected to the affects of an adjacent fire, such as





**Distribution Operations**

**Health, Safety and Environmental Standard**

|                               |   |  |
|-------------------------------|---|--|
| Effective Date:<br>01/09/1991 | <b>Propane Properties and Safety Considerations</b> | Standard Number:<br><b>HSE 4000.070(CG)</b><br>P&P 415-1 |
| Supersedes:<br>N/A            |   | Page 4 of 12   |

from a burning building or another fuel source, it is of prime importance to apply water to the tank's outer shell and piping.

If the LP storage tank becomes heated to the point of causing the relief valve to function, the discharge should be allowed to burn if it becomes ignited or in some circumstances, it may be desirable to ignite the discharge. Continue to spray water on tank and piping to cool the tank and after the relief valve has closed to prevent excess pressure from building up again from the residual heat of the fire.

Portable LP gas cylinders that are exposed to heat of a fire should be moved to a safe location. While cylinders are equipped with spring loaded relief valves and are relatively safe to handle, moving should be done with extreme caution. Cylinders should be cooled before moving.

**3.5 Explosion Prevention**

When propane is released an explosion may occur when an ignition source is available. Therefore, sources of ignition should be eliminated from the job site. Some possible sources of ignition are running engines, electric motors, switches, lanterns, flares, lighted cigarettes, welding/cutting torches and matches/lighters.

Traffic control shall be exercised to prevent vehicles from entering propane vapor leakage areas to prevent ignition.

The hazard of explosion is much greater in areas such as excavations, vaults, buildings, etc.

**3.6 Asphyxiation Prevention**

Breathing an oxygen deficient atmosphere may result in unconsciousness in less than one minute and can result in asphyxiation. It is important to know that leaking propane gas can displace oxygen from manholes, vaults, pits, buildings, excavations, etc. This is true since propane is heavier than air.

Since propane tends to collect in low places, consideration should be given to:

- a. controlling the source of propane
- b. ventilating
- c. monitoring the atmosphere
- d. using life lines
- e. using respiratory and/or other personal protection equipment



**Distribution Operations**

**Health, Safety and Environmental Standard**

|                               |   |  |
|-------------------------------|---|--|
| Effective Date:<br>01/09/1991 | <b>Propane Properties and Safety Considerations</b> | Standard Number:<br><b>HSE 4000.070(CG)</b><br>P&P 415-1 |
| Supersedes:<br>N/A            |   | Page 5 of 12   |

Further guidance is provided in [HSE 4100.010](#) "Hazardous Atmosphere Considerations."

**3.7 Freezing Prevention**

Liquid propane when it evaporates produces an extremely low temperature. Therefore, precaution shall be exercised to prevent liquid propane from contacting skin. Such contact will result in a painful skin "freeze-burn."

Thermal gloves, face shields, and protective clothing shall be worn any time there is a chance of contact with liquid propane.



Distribution Operations

Health, Safety and Environmental Standard

|                               |   |  |
|-------------------------------|---|--|
| Effective Date:<br>01/09/1991 | <b>Propane Properties and Safety Considerations</b> | Standard Number:<br><b>HSE 4000.070(CG)</b><br>P&P 415-1 |
| Supersedes:<br>N/A            |   | Page 6 of 12   |

**EXHIBIT A  
(1 OF 7)**

**PROPANE HD-5 FACT SHEET**

**I. GENERAL**

TRADE NAME:

Propane HD-5

OTHER NAMES:

Liquefied, Low Sulfur, Propane  
Liquefied Petroleum Gas or LP-Gas or L.P.G.

Dimethylmethane

CHEMICAL FAMILY:

Paraffin Hydrocarbons

GENERIC NAME:

Alkane Hydrocarbon

CAS NO:

74-98-6

DOT HAZARDOUS MATERIALS PROPER SHIPPING NAME:

Propane or Liquefied Petroleum Gas

DOT HAZARD CLASS:

Flammable Gas

UN/NA ID NUMBER:

UN 1075

**II. SUMMARY OF HAZARDS**

**EXTREMELY FLAMMABLE! OSHA/NFPA CLASS-IA FLAMMABLE GAS.  
KEEP AWAY FROM HEAT, SPARKS, AND OPEN FLAME.**

**VAPOR REDUCES OXYGEN AVAILABLE FOR BREATHING!  
USE ONLY WITH ADEQUATE VENTILATION.  
ODOR IS AN INADEQUATE WARNING OF  
POTENTIALLY HAZARDOUS AIR CONCENTRATIONS.**

**MAY CAUSE FROSTBITE OR FREEZE BURNS!  
AVOID EXPOSURE TO LIQUID OR CRYOGENIC GAS VAPOR.**



Distribution Operations

Health, Safety and Environmental Standard

|                               |   |  |
|-------------------------------|---|--|
| Effective Date:<br>01/09/1991 | <b>Propane Properties and Safety Considerations</b> | Standard Number:<br><b>HSE 4000.070(CG)</b><br>P&P 415-1 |
| Supersedes:<br>N/A            |   | Page 7 of 12   |

**EXHIBIT A  
(2 OF 7)**

**III. FIRE AND EXPLOSION**

FLASH POINT:

GT -160°F. (EST.) (See FIRE AND EXPLOSION HAZARDS)

AUTOIGNITION TEMPERATURE (METHOD):

AP 840°F. (EST.)

Based upon "Propane"

FLAMMABLE LIMITS (%VOL. IN AIR) AT NORMAL ATMOSPHERIC TEMPERATURE AND PRESSURE:

Lower AP 2.1 Upper AP 9.5

Based upon "Propane"

FIRE AND EXPLOSION HAZARDS:

This gas releases flammable vapors at well below ambient temperatures and readily forms flammable mixtures with air. Exposed to an ignition source, it will burn in the open or be explosive in confined spaces. Its vapors are heavier than air and may travel long distances to a point of ignition, and then flash back. Alkane/Chlorine gas mixtures have produced explosions.

EXTINGUISHING MEDIA:

Dry Chemical

CO<sub>2</sub>

Halogenated Extinguishing Agent

SPECIAL FIRE FIGHTING PROCEDURES:

Gas fires should not be extinguished unless the gas flow can be stopped immediately. Shut off gas source and allow the fire to burn itself out. If the source cannot be shut off immediately, all equipment surfaces exposed to the fire should be cooled with water to prevent overheating, flashbacks, or explosions. Control fire until gas supply can be shut off. Fireman must use proper protective equipment including respiratory apparatus to protect against hazardous combustion products/oxygen deficiencies.

**IV. HEALTH HAZARDS**

SUMMARY OF ACUTE HAZARDS:

Asphyxiation (See INHALATION)

Freeze Burns



**Distribution Operations**

**Health, Safety and Environmental Standard**

|                               |   |  |
|-------------------------------|---|--|
| Effective Date:<br>01/09/1991 | <b>Propane Properties and Safety Considerations</b> | Standard Number:<br><b>HSE 4000.070(CG)</b><br>P&P 415-1 |
| Supersedes:<br>N/A            |   | Page 8 of 12   |

**EXHIBIT A  
(3 OF 7)**

**INHALATION:**

Exposure may produce rapid breathing, headache, dizziness, visual disturbance, muscular weakness, tremors, narcosis, unconsciousness, and death, depending on concentration and time of exposure.

**EYE CONTACT:**

This gas is non-irritating; but direct contact with liquefied/pressurized gas or frost particles may produce severe and possibly permanent eye damage from freeze burns.

**SKIN ABSORPTION:**

This material is not expected to be absorbed through the skin.

**SKIN IRRITATION:**

Non-irritating, but solid and liquid forms of this material and pressurized gas can cause freeze burns.

**INGESTION:**

Solid and liquid forms of this material and the pressurized gas can cause freeze burns.

**SUMMARY OF CHRONIC HAZARDS AND SPECIAL HEALTH EFFECTS:**

Inhalation may produce mild intoxication, drowsiness or loss of coordination. High concentrations produce intoxication followed by loss of consciousness, asphyxiation and death.

Caution is recommended for personnel with pre-existing central nervous system disorders. Personnel with pre-existing chronic respiratory diseases should refrain from breathing this material.

**V. PROTECTIVE EQUIPMENT AND OTHER CONTROL MEASURES**

**RESPIRATORY:**

For excessive gas concentrations, use only NIOSH/MSHA approved, self-contained breathing apparatus. (See OTHER HYGIENE AND WORK PRACTICES)

**EYE:**

Use chemical-type goggles and face shield when handling liquefied gases. Safety glasses and/or face shields are recommended when handling high-pressure cylinders and piping systems and whenever vapors are discharged.



Distribution Operations

Health, Safety and Environmental Standard

|                               |   |  |
|-------------------------------|---|--|
| Effective Date:<br>01/09/1991 | <b>Propane Properties and Safety Considerations</b> | Standard Number:<br><b>HSE 4000.070(CG)</b><br>P&P 415-1 |
| Supersedes:<br>N/A            |   | Page 9 of 12   |

**EXHIBIT A  
(4 OF 7)**

**SKIN:**

Prevent potential skin contact with cold liquid/vapors. Use insulated, impervious plastic or neoprene-coated canvas gloves and protective gear (apron, face shield, etc.) to protect hands and other skin areas.

**ENGINEERING CONTROLS:**

Local exhaust and general room ventilation may both be essential in work areas to prevent accumulation of explosive mixtures. If mechanical ventilation is used, electrical equipment must meet N.E.C. requirements.

**OTHER HYGIENIC AND WORK PRACTICES:**

Emergency eye wash fountains and safety showers should be available in the vicinity of any potential exposure. (See Sections IV and VIII.)

Personnel should not enter areas where the atmosphere is below 19.5 vol.% oxygen without special procedures/equipment. Respirator use should comply with OSHA 29 CFR 1910.134 or equivalent.

**VI. OCCUPATIONAL EXPOSURE LIMITS**

**SUBSTANCE:**

|                                  | <u>Source</u> | <u>Date</u> | <u>Type</u> | <u>Value/Units</u> | <u>Time</u> |
|----------------------------------|---------------|-------------|-------------|--------------------|-------------|
| Liquefied Petroleum Gas (L.P.G.) | OSHA          | 1984        | PEL         | 1000 PPM           | 8 hrs       |
|                                  | ACGIH         | 1984        | TIV         | 1000 PPM           | 8 hrs       |
|                                  |               |             | STEL        | 1250 PPM           | 15 min      |
| Propylene - "Simple Asphyxiant"  | ACGIH         | 1984        |             |                    |             |
| Propane                          | OSHA          | 1984        | PEL         | 1000 PPM           | 8 hrs       |
| Propane - "Simple Asphyxiant"    | ACGIH         | 1984        |             |                    |             |

**VII. EMERGENCY FIRST AID**

**INHALATION:**

Immediately move personnel to area of fresh air. For respiratory distress, give air, oxygen or administer CPR (cardiopulmonary resuscitation). If necessary, obtain medical attention if breathing difficulties continue.



Distribution Operations

Health, Safety and Environmental Standard

|                               |   |  |
|-------------------------------|---|--|
| Effective Date:<br>01/09/1991 | <b>Propane Properties and Safety Considerations</b> | Standard Number:<br><b>HSE 4000.070(CG)</b><br>P&P 415-1 |
| Supersedes:<br>N/A            |   | Page 10 of 12  |

**EXHIBIT A  
(5 OF 7)**

**EYE CONTACT:**

Vapors are not expected to present an eye irritation hazard. If contacted by liquid/solid, immediately flush the eye(s) gently with warm water for at least 15 minutes. Seek medical attention if pain or redness persists.

**SKIN CONTACT:**

Frozen tissues should be flooded or soaked with warm water (105-115°F.). Do not use hot water! Cryogenic burns which result in blistering or deeper tissue freezing should be promptly seen by a physician.

**INGESTION:**

Induce vomiting with warm water (quart) only if patient is conscious. Immediately obtain medical attention.

**EMERGENCY MEDICAL TREATMENT PROCEDURES:**

See above procedures.  
Personnel with pre-existing skin disorders or chronic respiratory diseases should avoid exposure to this product.

**VIII. SPILL AND DISPOSAL**

**PRECAUTIONS IF MATERIAL IS SPILLED OR RELEASED:**

Eliminate all potential sources of ignition. Evacuate all non-essential personnel to an area upwind. (At least one-half mile in all directions if tanks or tank cars are involved in fire.) Stop source of release with non-sparking tools before putting out any fire. Ventilate enclosed areas to prevent formation of flammable or oxygen-deficient atmospheres. Water spray may be used to reduce vapors. Closed systems form white frost at the point of leak. Liquid spills will vaporize forming cold dense vapor cloud even with proper respiratory equipment.

**WASTE DISPOSAL METHODS:**

Releases are expected to cause only localized environmental damage. Waste mixtures containing these gases should not be allowed to enter drains or sewers where there is danger of their vapors becoming ignited. When it becomes necessary to dispose of these gases, it is preferable to do so as vapor. Unused product may be used as an auxiliary fuel or disposed by burning in a properly designed flare or incinerator. Venting of gas to the atmosphere should be avoided. Defective, empty, or partially used portable containers should be returned to the supplier with appropriate tags.



Distribution Operations

Health, Safety and Environmental Standard

|                               |   |  |
|-------------------------------|---|--|
| Effective Date:<br>01/09/1991 | <b>Propane Properties and Safety Considerations</b> | Standard Number:<br><b>HSE 4000.070(CG)</b><br>P&P 415-1 |
| Supersedes:<br>N/A            |   | Page 11 of 12  |

**EXHIBIT A  
(6 OF 7)**

**IX. COMPONENTS**

\* \* THIS MAY NOT BE A COMPLETE LIST OF COMPONENTS \* \*

| COMPONENT NAME | CAS NO.   | CARCINOGEN ## |    | COMPOSITION AMOUNT (VOL.)<br>(See Qualification on page 7) |
|----------------|-----------|---------------|----|--|
| Propane        | 74-98-6   | N/AP          | GT | 90-95 percent  |
| Propylene      | 115-07-01 | N/AP          | LT | 0- 5 percent   |
| Iso-Butane     | 75-28-5   | N/AP          | LT | 0-2.5 percent  |

Compositions given are typical values, not specifications.

## Listed by: 1=NIP, 2=IARC, 3=OSHA, 4=Other

**X. PHYSICAL AND CHEMICAL DATA**

BOILING POINT:

AP -45°F.

FREEZING POINT:

AP -305°F.

SPECIFIC GRAVITY:

(H<sub>2</sub>=at 39.2°F.) AP 0.52

HAZARDOUS POLYMERIZATION:

not expected to occur

VISCOSITY UNITS, TEMP. (METHOD):

N/AP

VAPOR PRESSURE:

(PSIA at 100°F) AP 190 to 205

VAPOR SP. GR."

(Air = 1.0 at 60-90°F.) AP 1.5

OTHER CHEMICAL REACTIVITY:

N/P





Distribution Operations

Health, Safety and Environmental Standard

|                               |   |  |
|-------------------------------|---|--|
| Effective Date:<br>01/09/1991 | <b>Propane Properties and Safety Considerations</b> | Standard Number:<br><b>HSE 4000.070(CG)</b><br>P&P 415-1 |
| Supersedes:<br>N/A            |   | Page 12 of 12  |

**EXHIBIT A  
(7 OF 7)**

VOLATILE CHARACTERISTICS:

complete

STABILITY:

stable

SOLUBILITY IN WATER:

moderate

DRY POINT:

N/AP

pH:

N/AP

OTHER PHYSICAL AND CHEMICAL PROPERTIES:

Gross heat of combustion @ 60°F. = 21,650 BTU/LB or 2,550 BTU/FT<sup>3</sup>

APPEARANCE AND ODOR:

Colorless gas (liquid under pressure): propane sold for use as fuel contains mercaptan odorant.

CONDITIONS TO AVOID:

Heat, sparks, and open flames.

MATERIALS TO AVOID:

Strong acids, alkalines, and oxidizers such as chlorine (gas or liquid) and oxygen.

HAZARDOUS DECOMPOSITION PRODUCTS:

Combustion may produce carbon monoxide and other harmful substances.

-----  
\* \* NOTE - Qualifications:

EQ = Equal

LT = Less Than

TR = Trace

AP = Approximately

UK = Unknown

N/AP = Not Applicable

GT = Greater Than

N/DA = No Data Available

N/P = No Applicable Information Found  
-----



**Health, Safety and Environmental Standard**

**Distribution Operations**

|                               |                              |  |
|-------------------------------|------------------------------|--|
| Effective Date:<br>12/03/1984 | <b>Fire Control Training</b> | Standard Number:<br><b>HSE 4000.080(CG)</b><br>P&P 420-2 |
| Supersedes:<br>N/A            |                              | Page 1 of 4  |

Companies Affected:

|                                     |   |   |
|-------------------------------------|---|---|
| <input type="checkbox"/> NIPSCO     | <input type="checkbox"/> CGV            | <input checked="" type="checkbox"/> CMD |
| <input type="checkbox"/> NIFL       | <input checked="" type="checkbox"/> CKY | <input checked="" type="checkbox"/> COH |
| <input type="checkbox"/> Kokomo Gas | <input type="checkbox"/> CMA            | <input checked="" type="checkbox"/> CPA |

**REFERENCE** OSHA 1926.24 CGS Manual of Approved Procedure for Operations Committee 19 Approved Recommendation No. 29, memoranda signed by Operative Vice Presidents dated 9-26-80, 4-7-81 and 1-11-82.

**1. GENERAL**

These program are designed to prepare participants to recognize and effectively cope with fire related emergencies. The knowledge and skill developed through participation could, in the event of an emergency, save lives and property.

**2. EMPLOYEE FIRE CONTROL TRAINING**

District Managers shall ensure that personnel at each work location who may be exposed to fires participate in the fire control training program as stipulated in the Fire Control Instructor's Manual. Employee selected for participation shall receive refresher training at intervals not exceeding five (5) years.

Personnel who are assigned duties as fire wardens or watchers in office, warehouses, welding shops, etc., shall participate in the fire control program as stipulated in the Fire Prevention for Home and Office Instructor's Manual. Other District and General Office employees, at the discretion of the Department Heads/District Managers, should be afforded an opportunity to participate. Personnel assigned as fire wardens/watchers or similar duties shall receive refresher training at intervals not exceeding five (5) years.

**3. FIRE EXTINGUISHER MAINTENANCE TRAINING**

Personnel assigned the responsibility for fire extinguisher inspection, maintenance and recharge shall be trained according to the requirements stipulated in Script III of the Fire Control Instructions Manual and the accompanying slide/tape program. Refer to [HSE 4000.082\(CG\)](#) "Portable Fire Extinguishers – Inspection and Maintenance."

**4. ACCOUNTABILITY**

Managers/Supervisors shall be responsible for ensuring the scheduling of employees who have been selected for participation in the initial and/or refresher training according to the provisions of this policy/procedure.

*This document is considered CONTROLLED only when viewed electronically on the Company's intranet. Printed or other electronic copies may not be current, and the intranet version should be used to verify.*



**Distribution Operations**

**Health, Safety and Environmental Standard**

|                               |                              |  |
|-------------------------------|------------------------------|--|
| Effective Date:<br>12/03/1984 | <b>Fire Control Training</b> | Standard Number:<br><b>HSE 4000.080(CG)</b><br>P&P 420-2 |
| Supersedes:<br>N/A            |                              | Page 2 of 4  |

District Safety and Health Specialists shall be responsible for conducting and/or coordinating fire control training in each district.

Safety and Health Section personnel shall be responsible for conducting and/or coordinating fire control training for general office employees as requested or required.

**5. RECORD KEEPING**

Employee participation in Fire Control Training programs shall be recorded on Form C-2242, "Training Record Entry Document - Batch Control" (Exhibit A).

**6. FIRE CONTROL TRAINING CERTIFICATE**

The Fire Control Training Certificate, Form C 754-1 (Exhibit B) is presented to employees who have actively participated in the CDC Fire Control Training Program.



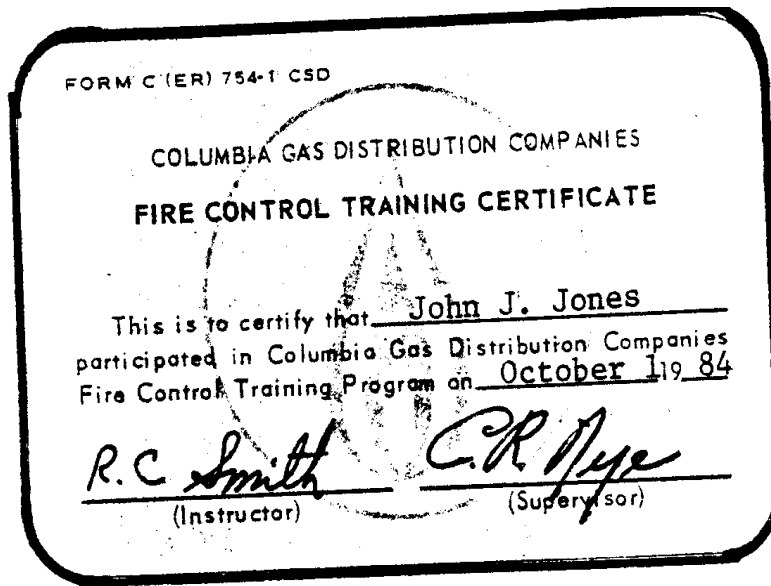


Distribution Operations

Health, Safety and Environmental Standard

|                               |                              |  |
|-------------------------------|------------------------------|--|
| Effective Date:<br>12/03/1984 | <b>Fire Control Training</b> | Standard Number:<br><b>HSE 4000.080(CG)</b><br>P&P 420-2 |
| Supersedes:<br>N/A            |                              | Page 4 of 4  |

EXHIBIT B





Distribution Operations

Health, Safety and Environmental Standard

|                               |   |   |
|-------------------------------|---|---|
| Effective Date:<br>07/01/2013 | <b>Portable Fire Extinguishers -<br/>Inspection and Maintenance</b> | Standard Number:<br><b>HSE 4000.082</b> |
| Supersedes:<br>N/A            |   | Page 1 of 4                             |

Companies Affected:

|                                 |   |   |
|---------------------------------|---|---|
| <input type="checkbox"/> NIPSCO | <input checked="" type="checkbox"/> CGV | <input checked="" type="checkbox"/> CMD |
|                                 | <input checked="" type="checkbox"/> CKY | <input checked="" type="checkbox"/> COH |
|                                 | <input checked="" type="checkbox"/> CMA | <input checked="" type="checkbox"/> CPA |

**REFERENCE** Code of Federal Regulations - Title 29 - Part 1910 - § 1910.157 NFPA 10

**1. GENERAL**

Portable fire extinguishers shall have Form HSE 4000.082-1, "Fire Extinguisher Record Tag," (Exhibit A) or an equivalent tag provided by the servicing inspection/maintenance contractor attached to the extinguisher. An exception is, in the case of a fire extinguisher mounted on a truck, the tag need not be attached but may be maintained in a water tight compartment on the truck readily available for inspection.

The date of each monthly inspection and annual maintenance check along with the initials of the person performing these inspections shall be posted to the tag. The serial number of the extinguisher shall also be recorded on the tag. The date of the most recent hydrostatic test and frequency shall also be indicated on the tag, when appropriate.

If an employee is assigned the duty of performing the monthly inspection or annual maintenance check, the employee shall be knowledgeable in the inspection and maintenance requirements as provided by the manufacturer and NFPA 10, "Portable Fire Extinguishers." The local HSE Coordinator can provide the employee with the necessary inspection and maintenance training.

**2. MONTHLY INSPECTION**

Monthly inspection of extinguishers shall include a check of at least the following items:

- a. Located in designated place and identified by proper signs.
- b. No obstruction to access or visibility.
- c. Operating instructions on nameplate legible and facing outward.
- d. Seals and tamper indicators not broken or missing.
- e. Determine fullness by weighing or "hefting".
- f. Examine for obvious physical damage, corrosion, leakage or clogged nozzle.
- g. Pressure gage reading or indicator in the operable range or position.

*This document is considered CONTROLLED only when viewed electronically on the Company's intranet. Printed or other electronic copies may not be current, and the intranet version should be used to verify.*



**Distribution Operations**

**Health, Safety and Environmental Standard**

|                               |   |   |
|-------------------------------|---|---|
| Effective Date:<br>07/01/2013 | <b>Portable Fire Extinguishers -<br/>Inspection and Maintenance</b> | Standard Number:<br><b>HSE 4000.082</b> |
| Supersedes:<br>N/A            |   | Page 2 of 4                             |

**3. ANNUAL MAINTENANCE CHECK**

Extinguishers shall be given maintenance checks annually and whenever an inspection indicates the need. Annual maintenance checks are thorough examinations of the extinguisher and the performance of any necessary repair or replacement. The following items shall be checked for each type of extinguisher, and in addition the manufacturer's recommendations for maintenance should be followed:

- a. Cartridge Operated Extinguishers
  - 1. mechanical parts
  - 2. extinguishing agent
  - 3. expelling agent
  - 4. 12 year hydrostatic test
- b. Rechargeable Stored Pressure Dry Chemical and Halon Extinguishers
  - 1. external condition check
  - 2. 12 year hydrostatic test
  - 3. six year: empty and subject to applicable maintenance/manufacturer recommendations
  - 4. Halon must be recovered with a Halon recovery system
- c. Rechargeable Carbon Dioxide Extinguishers
  - 1. examine condition of the shell and hose assembly
  - 2. weigh the extinguisher
  - 3. perform conductivity check on hose assembly
  - 4. five year hydrostatic test
- d. Non-rechargeable Stored Pressure Dry Chemical and Halon Extinguishers
  - 1. external condition checks
  - 2. discard after 12 years or if damaged
  - 3. Halon must be recovered before disposal
  - 4. dry chemical units must be discharged before disposal
- e. Other Portable Fire Extinguishers

For other types of fire extinguishers follow the manufacturer's maintenance procedures, OSHA requirements and NFPA 10 recommendations.

**4. HYDROSTATIC TESTING**

Dry chemical and Halon extinguishers shall be hydrostatic tested every 12 years.



**Distribution Operations**

**Health, Safety and Environmental Standard**

|                               |   |   |
|-------------------------------|---|---|
| Effective Date:<br>07/01/2013 | <b>Portable Fire Extinguishers -<br/>Inspection and Maintenance</b> | Standard Number:<br><b>HSE 4000.082</b> |
| Supersedes:<br>N/A            |   | Page 3 of 4                             |

Carbon dioxide extinguishers shall be hydrostatic tested every five years.

The hydrostatic testing shall be performed by a qualified servicing contractor. The contractor shall maintain and provide, upon request to the Company, evidence that the required hydrostatic testing has been performed.

**5. CORRECTIVE ACTION**

When an inspection of any extinguisher reveals a deficiency in any of the conditions listed in Sections 2 or 3, immediate corrective action shall be taken.

**6. RECORDS**

HSE 4000.082-1 forms shall be kept for three years plus the current year.







Distribution Operations

## Health, Safety & Environmental Standard

|                               |  |   |
|-------------------------------|--|---|
| Effective Date:<br>01/01/2016 | <b>Hazardous Atmosphere<br/>Considerations</b> | Standard Number:<br><b>HSE 4100.010</b> |
| Supersedes:<br>01/01/2012     |  | Page 1 of 8                             |

Companies Affected:

|                                 |   |   |
|---------------------------------|---|---|
| <input type="checkbox"/> NIPSCO | <input checked="" type="checkbox"/> CGV | <input checked="" type="checkbox"/> CMD |
|                                 | <input checked="" type="checkbox"/> CKY | <input checked="" type="checkbox"/> COH |
|                                 | <input checked="" type="checkbox"/> CMA | <input checked="" type="checkbox"/> CPA |

### 1. PURPOSE

This document details the process and procedure to identify atmospheric hazards as well as measures to be taken to minimize risks to the employee. All excavations are considered hazardous unless determined otherwise.

### 2. SCOPE

This standard applies to all Company employees working in a hazardous atmosphere.

Additional requirements for entering excavations, vaults or pits that contain or are likely to contain a hazardous atmosphere are presented in the Company's Health, Safety & Environmental (HS&E) Standards HSE 4100.020 "Work Zone Protection", HSE 4100.030 "Safe Entry for Gas Vaults and Pits", and HSE 4100.040 "Excavation (Trenching) Safety".

### 3. RESPONSIBILITIES

All management, supervisors and employees that conduct work in or adjacent to a hazardous atmosphere share the responsibility to follow recognized safe work practices in the performance of their work.

Local management shall ensure that trained personnel are available to perform the work.

Trained and experienced personnel at the work site shall:

- a. Determine if a hazardous atmosphere exists or could reasonably be expected to exist,
- b. Consider appropriate control method(s) to eliminate or minimize any hazard, (refer to section 4.3 – Control Methods)
- c. Select and use the appropriate Personal Protective Equipment (PPE) as necessary.

*This document is considered CONTROLLED only when viewed electronically on the Company's intranet. Printed or other electronic copies may not be current, and the intranet version should be used to verify.*



**Distribution Operations**

**Health, Safety & Environmental Standard**

|                               |  |   |
|-------------------------------|--|---|
| Effective Date:<br>01/01/2012 | <b>Hazardous Atmosphere<br/>Considerations</b> | Standard Number:<br><b>HSE 4100.010</b> |
| Supersedes:<br>4/10/2010      |  | Page 2 of 8                             |

**4. PROCEDURE**

**4.1 Work Site Planning**

The following work site planning activities shall be conducted.

- a. Conduct a Pre-Job Briefing with all onsite parties.
- b. Determine if the pipeline is in service.
- c. Determine if the work site involves an excavation or a vault or a pit.
- d. Determine if a hazardous atmosphere exists or could reasonably be expected to exist.
- e. Assign personnel who are trained in situations where gas is escaping, or is likely to escape to the atmosphere.
- f. Select the appropriate control methods to eliminate or minimize any hazard.
- g. Select and use the appropriate PPE as necessary.
- h. Discuss communication and escape options.
- i. Other activities deemed appropriate.

**4.2 Test for Hazardous Atmospheres**

Excavations shall be tested to determine if a hazardous atmosphere exist at sufficient locations to assure safety prior to first time entry and conducted as often as necessary to ensure the atmosphere remains safe. If at any time the atmosphere becomes hazardous, exit the excavation, and re-evaluate the situation to determine if the hazard can be eliminated. (Combustible gas or vapor atmosphere/mixture is the area between the lower explosive limit (LEL) and upper explosive limit (UEL)). Natural gas has an approximate L.E.L. of 5.0% and U.E.L. of 15.0 %.)

An approved oxygen monitor shall be worn within the breathing zone by all employees at all times while in an excavation. If the oxygen content becomes less than 19.5% as indicated by a continuous oxygen monitor alarm, exit the excavation, and re-evaluate the situation to determine if the hazard can be eliminated. Additional action shall be taken to increase the oxygen level to 19.5% or greater (not to exceed 23.5% oxygen) by eliminating the flow of gas, if practical.

Testing, monitoring, and the use of controls as described (in Section 4.3) should also be considered when working in buildings and above ground locations in which hazardous or potentially hazardous atmospheres exist.

Additional requirements for working in vaults and pits that contain or are likely to



**Distribution Operations**

**Health, Safety & Environmental Standard**

|                               |  |   |
|-------------------------------|--|---|
| Effective Date:<br>01/01/2012 | <b>Hazardous Atmosphere<br/>Considerations</b> | Standard Number:<br><b>HSE 4100.010</b> |
| Supersedes:<br>4/10/2010      |  | Page 3 of 8                             |

contain hazardous atmospheres are presented in the Company's HS&E Standard, HSE 4100.030 "Safe Entry for Gas Vaults and Pits."

**4.3 Control Methods**

If practical, eliminate the flow of gas. Examples include:

- **Existing Valves**
- **Control Fittings**
- **Squeeze off**
- **Other approved line stopping methods**

If it is not practical to eliminate the flow of gas, consider using methods such as:

- **Purger**
- **Air Mover**
- **Ventilation**
- **Increase the size of the excavation**
- **Other approved engineering controls**

**4.4 Prevention of Accidental Ignition**

Adequate precautions shall be taken to minimize the danger of accidental ignition of gas prior to commencement and during live gas work tasks. Potential sources of ignition include operating equipment, cutting torches and welding equipment, non-intrinsically safe electrical equipment, static electricity, construction activity from an adjacent location, and sources of ignition caused by the public (e.g., cigarettes and lighted matches). Refer to GS 1770.010 "Prevention of Accidental Ignition" for additional guidance.

**5. PERSONAL PROTECTIVE EQUIPMENT (PPE)**

Personnel working in hazardous atmospheres shall use PPE in accordance with this section.

For additional PPE guidance refer to applicable HS&E standards.



|                               |  |   |
|-------------------------------|--|---|
| Effective Date:<br>01/01/2012 | <b>Hazardous Atmosphere<br/>Considerations</b> | Standard Number:<br><b>HSE 4100.010</b> |
| Supersedes:<br>4/10/2010      |  | Page 4 of 8                             |

**5.1 100 Percent Cotton Clothing**

If a verified non-hazardous atmosphere exists (Work Protection Hazard Level 1 – as defined in Table 1) and it can be reasonably expected to remain a non-hazardous atmosphere, personnel are permitted to wear 100% cotton short-sleeves, 100% cotton pants and any other required personal protective equipment (PPE).

Situations where monitoring indicates non-hazardous atmosphere (Work Protection Hazard Level 2) and the release of gas is controlled (i.e. Purging, Operating Self-Tapping T's, Controlled Drilling and Stopping). Personnel shall wear a minimum of a 100% cotton long-sleeve shirt and 100% cotton pants.

**5.2 Flame Resistant (FR) Clothing**

When required (see Table 1 below), flame resistant outer clothing shall be worn by all employees in the area that may be affected by the ignition of gas. FR clothing shall consist of an approved FR coverall and other approved FR garments including hood and gloves. When the conditions exist that require FR clothing, at least one above ground attendant shall be present. FR clothing is designed to protect personnel from potential fire hazards in the event of a flash fire resulting from a flammable hazardous atmosphere. It is the intent that the FR clothing will provide personnel with adequate time to escape a flash fire situation without serious burn injury. Face shields should also be used, if a Job Hazard Assessment deemed it appropriate.

Due to the hazard associated with heat transfer, the layer beneath the FR coverall shall consist of long sleeves, long pants, and shall not contain synthetic materials (e.g. nylon, polyester, etc.).

**5.3 Respiratory Protection Equipment**

Respiratory protection equipment is used to protect personnel in hazardous atmospheres and prevent inhalation of hot gases in situations that may pose a hazard for ignition. Local Operating Area leadership is responsible for maintaining this equipment in sanitary and proper working order and ensure this equipment is readily available. Personnel are required to undergo medical evaluation and fit testing prior to use of supplied air respirator equipment.

An attendant shall be provided for each employee wearing respiratory protection equipment consisting of a safety harness with a communication line. The attendant shall be equally equipped as the employee they are attending. An attendant must monitor the communication line above ground at all times to ensure the personal safety of the entrant. If necessary, the attendant will initiate action to facilitate in the removal of the employee from the hazardous atmosphere.



**Distribution Operations**

**Health, Safety & Environmental Standard**

|                               |  |   |
|-------------------------------|--|---|
| Effective Date:<br>01/01/2012 | <b>Hazardous Atmosphere<br/>Considerations</b> | Standard Number:<br><b>HSE 4100.010</b> |
| Supersedes:<br>4/10/2010      |  | Page 5 of 8                             |

The attendant shall be trained in the characteristics, limitations and use of the respiratory protective equipment. At least one attendant shall be trained in first aid.

When a common air supply (mother tank) is used an additional attendant shall monitor the air pressure and supply.

**5.4 Fire Extinguisher**

A fire extinguisher shall be positioned close to and up-wind of the excavation and be immediately available for use if required. The extinguisher shall be positioned in such a way that it may be utilized in an emergency situation.

**In a Work Protection Hazard Level 4, a fire extinguisher attendant shall be provided and be equipped at minimal Hazard Level 3.**

**5.5 Personal Protective Equipment (PPE) Guidelines**

Listed below in Table 1 are minimum PPE requirements for working in a hazardous atmosphere.. If at any time field conditions change from a non-hazardous to a hazardous atmosphere, then all appropriate PPE (and specialized equipment as necessary) shall be utilized. The requirements in Table 1 do not replace the required PPE specified in any of the other current company operating standards or work methods. Those standards may require a higher level of PPE to be worn than is noted in Table 1.



**Distribution Operations**

**Health, Safety & Environmental Standard**

|                               |  |   |
|-------------------------------|--|---|
| Effective Date:<br>01/01/2012 | <b>Hazardous Atmosphere<br/>Considerations</b> | Standard Number:<br><b>HSE 4100.010</b> |
| Supersedes:<br>4/10/2010      |  | Page 6 of 8                             |

TABLE 1

\* All excavations are considered hazardous unless determined otherwise.

| Work Protection Hazard Levels  | Description   | Minimum PPE Requirements   | Examples  |
|--|---|--|---|
| Hazard Level 1   | <p>Non-Hazardous Atmosphere – No Combustible Gas Present Acceptable Oxygen Levels Present</p> <p>A hazardous atmosphere is not reasonably expected to occur</p> | <p>100% Cotton Pants and Short-Sleeve Shirt</p> <p>Additional PPE may be necessary depending upon the work tasks being performed</p> | <p>Any work performed in a verified non-hazardous atmosphere</p> <p>Wrapping Pipe<br/>Installing Pipe<br/>Clean- Up<br/>Housekeeping</p>                          |
| Hazard Level 2   | <p>Controlled Gas Release</p> <p>Acceptable Oxygen Levels Present -</p>   | <p>100% Cotton Pants and Long-Sleeve Shirt</p> <p>Additional PPE may be necessary depending upon the work tasks being performed</p>  | <p>Purging<br/>Operating Self-Tapping T's<br/>Controlled Drilling &amp; Stopping</p>  |
| Hazard Level 3   | <p>Uncontrolled Release of Gas</p> <p>Acceptable Oxygen Levels Present</p>  | <p>FR Coverall, including hood and gloves.</p> <p>Additional PPE may be necessary depending upon the work tasks being performed</p>  | <p>Uncontrolled Tapping Equipment (i.e. Skinner)<br/>Bagging</p> <p>When a hazardous atmosphere is reasonably expected to occur (i.e. when working on a leak)</p> |
| <p>Note to Hazard Level 3 - When working in any excavation with an uncontrolled release of gas consideration should be given to the use of an SCBA to protect against the inhalation of hot gasses in the event of an ignition .</p> |   |  |   |



Distribution Operations

Health, Safety & Environmental Standard

|                               |  |   |
|-------------------------------|--|---|
| Effective Date:<br>01/01/2012 | <b>Hazardous Atmosphere<br/>Considerations</b> | Standard Number:<br><b>HSE 4100.010</b> |
| Supersedes:<br>4/10/2010      |  | Page 7 of 8                             |

|                |                                  |  |  |
|----------------|----------------------------------|--|--|
| Hazard Level 4 | Oxygen Deficient, toxic gas<br>- | FR Coverall, Hood, Gloves + SCBA/SAR + Harness/Communication Line<br><br>Additional PPE may be necessary depending upon the work tasks being performed | While performing any task where it is not possible to increase oxygen levels to 19.5% or greater or where toxic gasses are present |
|----------------|----------------------------------|--|--|

**6. TRAINING**

It is the responsibility of local management and HS&E to ensure that all employees whose work involves being in a hazardous atmosphere are provided appropriate safety training. Training shall include the following topics as a minimum:

- a. Atmospheric Monitoring – proper use, calibration, and maintenance of atmospheric testing equipment,
- b. Personal Protective Equipment – proper selection and use of PPE described in Section 4,
- c. Respiratory Protection,
- d. Fire Extinguisher.

Once every three (3) years, employees who may be required to wear respiratory equipment shall wear such equipment while performing a routine task (e.g., leak repair, tie-in, services, mains, abandonment) to develop a confidence level in using the equipment.

**7. RECORDS**

All training records and date of training shall be documented in either the Learning Management System (LMS) or the Company’s work management system.

**8. DEFINITIONS**

**Blowing Gas:** Any situation where gas is escaping from an open-ended pipe, tap hole or other relatively large hole.

**Breathing Zone:** The zone in which an employee’s head is located while working.





**Distribution Operations**

**Health, Safety & Environmental Standard**

|                               |  |   |
|-------------------------------|--|---|
| Effective Date:<br>01/01/2012 | <b>Hazardous Atmosphere<br/>Considerations</b> | Standard Number:<br><b>HSE 4100.010</b> |
| Supersedes:<br>4/10/2010      |  | Page 8 of 8                             |

**Combustible Gas:** Gas that is mixed with oxygen and will propagate flame when exposed to a source of ignition.

**Oxygen Deficient Atmosphere:** An atmosphere that has less than 19.5% oxygen.

**Oxygen Enriched Atmosphere:** An atmosphere that has more than 23.5% oxygen.

**Personal Protective Equipment:** Protective equipment that consists of items such as FR clothing, goggles, face shields, work gloves, hard hat, self-contained breathing apparatus or airline respirators, and other equipment which is not considered part of a person's personal wardrobe.

**Readily Available:** Available means on the job site, at the office location (shop), or in the possession of another work crew available to be dispatched to the job site.

**9. REGULATORY REFERENCES**

OSHA 29CFR 1926.650

DOT 49CFR §§192.605(b)(9) and 192.751



**Distribution Operations**

**Health, Safety and Environmental Standard**

|                               |                             |   |
|-------------------------------|-----------------------------|---|
| Effective Date:<br>04/01/2009 | <b>Work Zone Protection</b> | Standard Number:<br><b>HSE 4100.020</b> |
| Supersedes:<br>N/A            |                             | Page 1 of 6                             |

Companies Affected:

|                                     |   |   |   |
|-------------------------------------|---|---|---|
| <input type="checkbox"/> NIPSCO     | <input checked="" type="checkbox"/> CGV | <input checked="" type="checkbox"/> COH | <input checked="" type="checkbox"/> BSG |
| <input type="checkbox"/> NIFL       | <input checked="" type="checkbox"/> CKY | <input checked="" type="checkbox"/> CPA |   |
| <input type="checkbox"/> Kokomo Gas | <input checked="" type="checkbox"/> CMD |   |   |

**1. PURPOSE**

This document describes the process and procedures for the separation of pedestrian and vehicular traffic from NiSource distribution operations job sites.

**2. SCOPE**

This procedure applies to all NiSource distribution operations employees working in situations where traffic control is required (work zone). This procedure is based on The Millennium Edition of the Federal Highway Administration (FHWA) Manual on Uniform Traffic Control Devices (MUTCD) and outlines the requirements for the work area, street and highway signing and barricading. Individual state requirements may vary from the MUTCD requirements and the requirements of this policy. Because of this variation, leaders/supervisors must be familiar with the traffic-control requirements within their geographical areas and comply accordingly.

**3. RESPONSIBILITIES**

**3.1 Employees**

Employees are responsible for ensuring that work practices described in this document and those work practices identified in local training programs are followed.

Work zone activities may involve safety hazards not addressed by these work practices. It is the responsibility of the employee to evaluate work site conditions and request guidance from local management if there are additional concerns for employee safety.

Employees are to follow established work practices; establish a work zone only after receiving training and demonstrating their understanding of the safe work practices including the use of personal protective equipment.

**3.2 Leader/Supervisor**

The local leader/supervisor is responsibility for the following.

- a. Ensuring that all employees that enter an established work zone are provided appropriate safety training.



**Distribution Operations**

**Health, Safety and Environmental Standard**

|                               |                             |   |
|-------------------------------|-----------------------------|---|
| Effective Date:<br>04/01/2009 | <b>Work Zone Protection</b> | Standard Number:<br><b>HSE 4100.020</b> |
| Supercedes:<br>N/A            |                             | Page 2 of 6                             |

- b. Ensuring that employees have all equipment and materials necessary to establish a work zone appropriate for the area conditions including use of personal protective equipment.
- c. Ensuring that employees properly implement work zone protection through periodic work site inspections.

**4. PROCEDURE**

**4.1 Work Area Traffic Control Planning**

Advance planning for work zone protection shall be performed prior to the start of work activities as follows.

**4.1.1 Work Area**

Evaluate the work area to determine the dimensions of work site, the type of work zone (urban, suburban, rural and industrial), the number of employees, the type and speed of vehicles and pedestrian traffic, and the type and placement of work area equipment and vehicles, as well as other factors that impact the work being planned.

Note: Consider the following factors when evaluating the job site.

- a. Speed and volume of traffic.
- b. Curved or straight road.
- c. Hilly, crowned, or level road.
- d. Curbs, deep gutters and pedestrian walkways.
- e. Location and angles of intersections.
- f. Visibility.
- g. Weather.
- h. Time of day.

**4.1.2 Local Laws and Regulations**

Perform an evaluation of all local laws and regulations that relate to traffic controls, the number and types of barricades, traffic cones, flashers, flags, signs, road plates, and temporary pedestrian bridges that may be required. Placement of Company vehicles and/or equipment on the traffic side of the worksite for the added protection of employees should be considered.



Distribution Operations

Health, Safety and Environmental Standard

|                               |                             |   |
|-------------------------------|-----------------------------|---|
| Effective Date:<br>04/01/2009 | <b>Work Zone Protection</b> | Standard Number:<br><b>HSE 4100.020</b> |
| Supercedes:<br>N/A            |                             | Page 3 of 6                             |

**4.1.3 Flagging**

Determine whether the use of a flagger and/or law enforcement is necessary to warn oncoming traffic while the work zone is being established.

**4.2 Traffic-Control and Traffic Control Devices**

All traffic-control devices used on road or street construction or maintenance work must conform to the specifications of the Manual of Uniform Traffic-Control Devices for Street and Highways – Millennium Edition of the FHWA, MUTCD. They are to be installed at the beginning of construction/maintenance operations and be properly maintained and/or operated during work activities.

Devices for traffic control should be utilized for the current stage of work being performed. All devices that do not apply to existing job conditions are to be removed, covered, or turned so as not to be identified by oncoming traffic.

**4.2.1 Flaggers**

High visibility work vests shall be worn by flaggers at all times, as Referenced in “Guidance for Use of High Visibility Work Vests”. Vests shall meet the American National Standards Institute/International Safety Equipment Association (ANSI/ISEA) 107-1999 standard for “American National Standard for High-Visibility Safety Apparel”. High-visibility work vests shall be a conspicuity Class 2 garment and have contiguous areas of retro-reflective material encircling the torso.

The flagger must, at all times, be clearly visible to approaching traffic for a distance of approximately 150/500 feet in urban areas and 500/1,000 feet in rural areas. Other persons shall not be permitted to congregate around the flagger.

**4.2.2 Flagging Procedures**

STOP/SLOW paddles are to be the primary hand signal device. Flags can be used in emergency situations or in low speed and/or low volume traffic conditions.

To stop traffic, the flagger shall face traffic and aim the Stop/Slow paddle face towards traffic with arm extended horizontally from body. Free arm is held with palm of hand above shoulder level.

When it is safe for traffic to proceed, the flagger will face traffic with the SLOW paddle facing traffic. The flagger will motion with free hand for traffic to proceed.



Distribution Operations

Health, Safety and Environmental Standard

|                               |                             |   |
|-------------------------------|-----------------------------|---|
| Effective Date:<br>04/01/2009 | <b>Work Zone Protection</b> | Standard Number:<br><b>HSE 4100.020</b> |
| Supercedes:<br>N/A            |                             | Page 4 of 6                             |

To alert or slow traffic, the flagger will face traffic with the SLOW paddle face towards traffic with arm extended horizontally away from body.

**4.2.3 Signaling Devices**

Sign paddles shall be a minimum of 18 inches wide with 6 inch letters. A rigid handle should be used. The background of the STOP paddle shall be red with white letters and border. The background of the SLOW paddle shall be orange with black letters and border. When used at night, or when conditions such as snow, rain, fog, etc. are present, the equipment shall be reflective.

Flags used for signaling devices shall be a minimum of 24 x 24 inches in size, red in color, and firmly fastened to a staff approximately three feet in length. The free edge should be weighted to permit the flag to hang vertically.

**4.3 Warning Signs**

Warning signs for maintenance and construction projects are used to notify drivers of specific hazards. For example, an open excavation may be present at or near the roadway. Drivers must be properly alerted to possible dangers ahead in sufficient time to adjust their speed for the hazard. The warning sign(s) shall be placed on the right side of the road so that it will effectively convey its message, be six feet above pavement and crashworthy.

Signs used for construction and maintenance shall be diamond shaped (with one diagonal vertical), having a black symbol or message on an orange fluorescent red-orange or fluorescent yellow-orange background.

Where open-highway conditions and fast-moving traffic prevail, advance warning signs should be placed approximately 1,500 feet in advance of the work site. On city streets where more-restrictive conditions generally prevail on the approach to the work site, signs may be placed at closer intervals.

Advance Warning Signs must be at least 36 x 36 inches. Where posted highway speeds are greater than 40 MPH, such signs are to be 48 x 48 inches in size.

Where other warning signs are used, they must conform to the minimum state requirements and/or the requirements of *Manual of Uniform Traffic-Control Devices for Streets and Highways*.

**Note:** To eliminate the necessity of purchasing and handling two sizes of the same sign, when purchasing new signs, consideration should be given to the purchase of only the larger size sign.



Distribution Operations

## Health, Safety and Environmental Standard

|                               |                             |   |
|-------------------------------|-----------------------------|---|
| Effective Date:<br>04/01/2009 | <b>Work Zone Protection</b> | Standard Number:<br><b>HSE 4100.020</b> |
| Supercedes:<br>N/A            |                             | Page 5 of 6                             |

### 4.4 Barricades and Channeling Devices

Barricades and channeling devices are to warn and alert pedestrians and drivers of hazards created by construction or maintenance activities in or near the traveled way and to guide and direct the public safely past the hazard.

Barricades shall be of the Type I or Type II barricade. Markings for barricade rails shall be either alternating orange and white or black and white stripes sloping downward at an angle of 45 degrees in the direction traffic is to travel. Because state requirements may vary, state requirements shall be followed. The entire area of the white and orange stripes shall have reflective surfaces.

Traffic cones shall be a minimum of 28 inches in height with a broadened base. Orange shall be the predominant color of traffic cones. For nighttime use, they must have reflective surfaces or be equipped with lighting devices for maximum visibility.

**Note:** All traffic cones must conform to the minimum state and/or local requirements.

Barricade warning lights that emit a yellow light may be placed on barricades or other channeling devices for the purpose of warning pedestrians or drivers that they are approaching a hazardous area.

### 4.5 Excavations

All excavations shall comply with HSE 4100.040, "Excavation (Trenching) Safety".

## 5. TRAINING

It is the responsibility of local management to ensure that all leaders/supervisors and employees whose work involves traffic or pedestrian hazards are provided work zone safety training. Training shall include the following topics as a minimum.

- a. Work area evaluation.
- b. Traffic control devices.
- c. Excavation safety.

## 6. RECORDS

All training sessions and dates of training shall be documented and recorded in the NiSource Learning Management System.



**Distribution Operations**

**Health, Safety and Environmental Standard**

|                               |                             |   |
|-------------------------------|-----------------------------|---|
| Effective Date:<br>04/01/2009 | <b>Work Zone Protection</b> | Standard Number:<br><b>HSE 4100.020</b> |
| Supercedes:<br>N/A            |                             | Page 6 of 6                             |

**7. DEFINITIONS**

Not applicable.

**8. REFERENCES**

Millennium Edition of the *Federal Highway Administration (FHWA) Manual on Uniform Traffic Control Devices (MUTCD)*.



Distribution Operations

## Health, Safety and Environmental Standard

|                               |  |   |
|-------------------------------|--|---|
| Effective Date:<br>01/01/2012 | <b>Safe Entry Into<br/>Gas Vaults and Pits</b> | Standard Number:<br><b>HSE 4100.030</b> |
| Supersedes:<br>N/A            |  | Page 1 of 6                             |

Companies Affected:

|                                 |   |   |
|---------------------------------|---|---|
| <input type="checkbox"/> NIPSCO | <input checked="" type="checkbox"/> CGV | <input checked="" type="checkbox"/> CMD |
|                                 | <input checked="" type="checkbox"/> CKY | <input checked="" type="checkbox"/> COH |
|                                 | <input checked="" type="checkbox"/> CMA | <input checked="" type="checkbox"/> CPA |

**REFERENCE** 49 CFR 192

### 1. SCOPE

The following work practices apply to entry into Department of Transportation (DOT) regulated spaces according to 49 CFR 192 such as gas vaults, pits and other similar spaces. The entry is completed under normal operating conditions and the spaces may contain hazardous atmospheres only under unusual conditions.

### 2. DEFINITIONS

**Pit** – An underground structure with full-opening doors for entry.

**Vault** – An underground structure accessed through a limited means of access such as a manhole.

### 3. RESPONSIBILITIES

#### 3.1 Employees

Each person at the vault and pit work site is responsible for ensuring that work practices described in this document and those work practices identified in local training programs are followed.

Vault and pit entry work may involve safety hazards not addressed by these work practices. It is the responsibility of the person to evaluate work site conditions and request guidance from local management if there are additional concerns for employee safety.

All employees must follow established work practices and enter a vault or pit only after receiving training (see Section 5) and demonstrating their understanding of the safe work practices including the use of personal protective equipment when working in a vaults or pits.

#### 3.2 Leader/Supervisor

The local leader/supervisor is responsibility for the following.

*This document is considered CONTROLLED only when viewed electronically on the Company's intranet. Printed or other electronic copies may not be current, and the intranet version should be used to verify.*





**Distribution Operations**

**Health, Safety and Environmental Standard**

|                               |  |   |
|-------------------------------|--|---|
| Effective Date:<br>01/01/2012 | <b>Safe Entry Into<br/>Gas Vaults and Pits</b> | Standard Number:<br><b>HSE 4100.030</b> |
| Supersedes:<br>N/A            |  | Page 2 of 6                             |

- a. Ensure that all employees working adjacent to vaults and pits are provided appropriate safety training.
- b. Ensure work units that conducts work involving vaults and pits designate a person or persons as qualified and ensure that these persons receive training prior to performing any vault and pit entry activity.
- c. Ensure only qualified people perform the required duties and responsibilities at each work site.
- d. Ensure an evaluation of work site hazards is conducted by a qualified person.

**4. PROCEDURE**

**4.1 Work Practice Prior to Entry**

The following work practices shall be followed.

- a. All possible sources of ignition shall be kept away from the work area, except as may be required in the performance of the work. If hot work permits are required, appropriate work practices shall be followed. A trained attendant shall be on site to render emergency assistance.
- b. Spaces containing energized electrical equipment greater than 50 volts require a trained attendant to be on site.
- c. Engine exhaust will be kept away from the entrance opening.
- d. An entrant shall have available for use an approved and properly calibrated monitoring instrument(s) for the gases likely to be encountered.
- e. Portable flashlights, lighting fixtures and similar devices shall be of a type approved for Class I, Division 1, Group C or D, Hazardous Locations.
- f. A fire extinguisher shall be available at the entrance to the work area.
- g. In areas open to the public, barricades and/or barriers shall be placed to secure the work zone.
- h. When spaces are four (4) feet or more in depth, ladders or other suitable means shall be provided for entrance/exit. The top of any portable ladder shall extend a minimum of three (3) feet above the entry surface.
- i. When pits or vaults are greater than 6 feet in depth, fall protection shall be used.
- j. Before an entrance cover is removed, a determination will be made based on



Distribution Operations

Health, Safety and Environmental Standard

|                               |  |   |
|-------------------------------|--|---|
| Effective Date:<br>01/01/2012 | <b>Safe Entry Into<br/>Gas Vaults and Pits</b> | Standard Number:<br><b>HSE 4100.030</b> |
| Supersedes:<br>N/A            |  | Page 3 of 6                             |

temperature differences. If the cover is hot, loosen gradually to release any residual pressure, atmospheric pressure or hazardous atmosphere in the space.

- k. Initial testing will occur at a depth of not more than one (1) foot using available pry or vent holes or by lifting the edge of the cover slightly to admit the test instrument or a probe tube.
- l. In the event of a double cover, it will be necessary to remove the outer cover and partially lift the inner cover to make the initial test.
- m. Once the cover is removed and initial readings of the atmospheric monitor are within safe limits, additional atmospheric monitoring tests shall be made at various levels to include: mid-point, approximately one (1) foot from the bottom and at the bottom. These readings shall be accomplished from outside the space with sufficient time allowed at each monitoring level for the air-monitoring instrument to obtain a correct reading.
- n. Results of air monitoring tests shall determine further entry procedures.
- o. If the air monitoring tests show that there is no dangerous air contamination and/or oxygen deficiency within the space and there is no reason to believe that any is likely to develop, entry into and work within may proceed.
- p. If during the air monitoring tests, monitoring alarm set points are reached, entry shall not proceed until further evaluation is made and appropriate protective measures are taken.

**4.2 Procedures for Entry and Working in Vaults and Pits**

The following procedure shall be followed in non-hazardous spaces with no oxygen deficiency.

- a. Prior to entry, if flammable gases are detected, but at levels lower than 20% of the LEL, a continuous monitor may be used in lieu of forced-air ventilation. A trained attendant shall be on site to render emergency assistance. Entrants shall wear appropriate personal protection equipment including full body harness with attached life line.
- b. Immediately upon entering the vault, the atmosphere shall be tested in all areas and reevaluated for hazardous conditions and oxygen deficiency.
- c. If reevaluation confirms the non-hazardous condition and no oxygen deficiency, the atmosphere shall be continuous monitored.
- d. Upon entering the space, an entrant shall inspect the interior for abnormal or hazardous conditions that may affect their personal safety before beginning their assigned work.



**Distribution Operations**

**Health, Safety and Environmental Standard**

|                               |  |   |
|-------------------------------|--|---|
| Effective Date:<br>01/01/2012 | <b>Safe Entry Into<br/>Gas Vaults and Pits</b> | Standard Number:<br><b>HSE 4100.030</b> |
| Supersedes:<br>N/A            |  | Page 4 of 6                             |

The following procedure shall be followed in hazardous conditions or spaces with an oxygen deficiency.

- a. A trained attendant shall be on site to render emergency assistance.
- b. Entrants shall wear appropriate personal protection equipment including full body harness with attached life line.
- c. If there is an oxygen deficiency in the space or if flammable vapors are detected above safe levels, forced air ventilation shall be used to maintain conditions at safe levels and to prevent a hazardous concentration of flammable gases and vapors from accumulating.
- d. If forced-air ventilation is used, it shall begin before entry is made and shall be maintained long enough to ensure that a safe atmosphere exists and continue until all entrants are out of the space.
- e. When the depth of the space is greater than five (5) feet, a mechanical device shall also be available to retrieve entrant personnel.
- f. Immediately upon entering the vault, the atmosphere shall be tested in all areas and reevaluated for hazardous conditions and oxygen deficiency. The atmosphere shall be continuous monitored.
- g. Upon entering the space, an entrant shall inspect the interior for abnormal or hazardous conditions that may affect their personal safety before beginning their assigned work.

**5. TRAINING**

All employees entering the space or serving as attendants shall be trained in safe entry work procedures to recognize unsafe conditions, the use of the atmospheric monitoring device, the mechanical retrieval device, fall protection and CPR.

Refresher training shall be conducted at least every three (3) years.

**6. VAULT AND PIT ENTRY CHECK LIST**

A vault and pit entry check list (refer to Exhibit A) of each entry should be completed by the entrant, signed and dated, and kept at the site for the duration of the job. This check list should be available for review by any entrant at that site for the duration of the work activity.

The check list should be returned to the entrant's local operating area/center leader/supervisor and should be retained for seven (7) calendar days after completion of the work.

**7. TRAINING RECORDS**

All training sessions and dates of training shall be documented and recorded in the NiSource Learning Management System (LMS).



Distribution Operations

Health, Safety and Environmental Standard

|                               |  |   |
|-------------------------------|--|---|
| Effective Date:<br>01/01/2012 | <b>Safe Entry Into<br/>Gas Vaults and Pits</b> | Standard Number:<br><b>HSE 4100.030</b> |
| Supersedes:<br>N/A            |  | Page 5 of 6                             |

**EXHIBIT A  
(1 OF 2)**


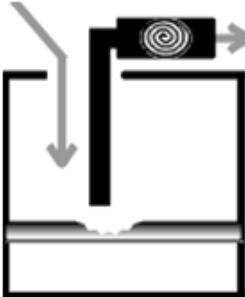
**Vault & Pit Entry Checklist**

| Location/address of the work space:                |                       |                  |                    |                    | Inventory #                        |             |
|--|-----------------------|------------------|--------------------|--------------------|------------------------------------|-------------|
| Date:  |                       | Time:            |                    | Supervisor:        |                                    |             |
| Employees involved in entry: _____                 |                       |                  |                    |                    |                                    |             |
| Scope of operations tasks: _____                   |                       |                  |                    |                    |                                    |             |
| Atmospheric hazards                                |                       |                  |                    |                    | Physical Hazards                   |             |
| Time:  | Oxygen                | %LEL             | CO                 | H2S                | Type (describe hazard & controls): | Controlled? |
|  | Between<br>19.5-23.5% | Less than<br>50% | Less than<br>50ppm | Less than<br>10ppm | Vehicle/pedestrian traffic         |             |
| Opening  |                       |                  |                    |                    | Ignition sources                   |             |
| Mid - Point  |                       |                  |                    |                    |                                    |             |
| Bottom   |                       |                  |                    |                    |                                    |             |
| Personal oxygen monitor used? ___Yes ___ No        |                       |                  |                    |                    | Fall protection                    |             |
| Combustible Gas Indicator ___Yes ___ No            |                       |                  |                    |                    | Fire Protection                    |             |
| Mechanical ventilation required? ___Yes ___ No     |                       |                  |                    |                    | Head                               |             |
| If yes, describe system:                           |                       |                  |                    |                    | Accumulating water                 |             |
|  |                       |                  |                    |                    | Slip/trip                          |             |
|  |                       |                  |                    |                    | Hazardous energy                   |             |
|  |                       |                  |                    |                    | Other                              |             |
|  |                       |                  |                    |                    |                                    |             |
| Signature of employee conducting site evaluations: |                       |                  |                    |                    |                                    |             |

|                               |  |   |
|-------------------------------|--|---|
| Effective Date:<br>01/01/2012 | <b>Safe Entry Into<br/>Gas Vaults and Pits</b> | Standard Number:<br><b>HSE 4100.030</b> |
| Supersedes:<br>N/A            |  | Page 6 of 6                             |

**EXHIBIT A  
(2 OF 2)**

**Vault & Pit Entry Checklist (cont'd)**

| Routine Entry Checklist<br>(record actions on front):  | Mechanical Ventilation Requirements   |
|--|---|
| <ul style="list-style-type: none"> <li>➤ Plan the entry. Define the scope of the work tasks, discuss hazards, and decide on controls.</li> <li>➤ Gather and inspect the equipment. All of the equipment needed for the entry should be brought to the site in preparation for the entry. The equipment must be inspected/tested as appropriate.</li> <li>➤ Place vehicles to protect employees and avoid potential exhaust contamination of the workspace.</li> <li>➤ Redirect/restrict pedestrian traffic from the work zone.</li> <li>➤ Survey the area for ignition sources.</li> <li>➤ Turn-on the 4-gas monitor to allow for warm-up and self-checks. When self-checks complete, perform field function tests to verify proper operation of alarms.</li> <li>➤ Test the workspace ports before opening (when appropriate). Position yourself upwind when opening the workspace.</li> <li>➤ Survey the workspace for physical hazards such as accumulating water, animals, head hazards, pinch points, slip/trip hazards, hazardous energy, and fall hazards. Record hazards on checklist and inform all employees on-site of these hazards and the controls &amp; protections to be used to achieve safe entry conditions.</li> <li>➤ Perform pre-entry atmospheric testing and record results.</li> <li>➤ Consider mechanical ventilation needs based on pre-entry sampling and work tasks to be performed.</li> <li>➤ Consider the need for outside attendants.</li> <li>➤ Discuss &amp; implement a communication system.</li> <li>➤ Discuss potential emergencies and prepare responses.</li> <li>➤ Conduct post-entry testing immediately after employees enter workspace.</li> <li>➤ Return site to safe operational condition</li> <li>➤ <u>after</u> work is performed.</li> </ul> <p>----- SAFE CONDITIONS FOR ENTRY -----</p> <p style="text-align: center;"><b>ATMOSPHERIC HAZARDS</b></p> <ul style="list-style-type: none"> <li>· Oxygen                      Between 19.5% - 23.5%</li> <li>· %LEL                              Less than 20% LEL</li> <li>· H<sub>2</sub>S                                Less than 10 ppm</li> <li>· CO                                 Less than 50 ppm</li> </ul> | <p style="text-align: center;">---- MECHANICAL VENTILATION MUST BE USED ----WHENEVER MONITORING INDICATES</p> <ol style="list-style-type: none"> <li>1. Mechanical ventilation is required for work in pits whenever: <ul style="list-style-type: none"> <li>· Gas is vented inside of the space; or,</li> <li>· Coatings/paints are applied or solvent-based cleaners are used inside the space; or,</li> <li>· Monitoring device detects other than normal condition (&gt;50% LEL, &lt;19.5% Oxygen, Toxics &gt; PELs).</li> </ul> </li> <li>2. Mechanical ventilation is required in vaults whenever coatings/paints are applied or solvent-based cleaners are used inside of the space</li> <li>3. Mechanical ventilation is generally not need in the following work situations: <ul style="list-style-type: none"> <li>· In full-opening vaults with both doors fully open, if the work space is continuously monitored for %LEL, %O<sub>2</sub>, Toxics; and individual breathing zones are monitored for oxygen (see #2 above).</li> <li>· In pits and vaults where work is limited to visual inspections, quick adjustments or chart changes, and where monitoring shows that natural ventilation is adequate to maintain acceptable entry conditions.</li> </ul> </li> </ol> <p style="text-align: center;">----- SAMPLES OF EFFECTIVE VENTILATION -----</p> <div style="display: flex; justify-content: space-around; align-items: center;"> <div style="text-align: center;">  <p>General</p> </div> <div style="text-align: center;">  <p>Local</p> </div> </div> |



## Health, Safety and Environmental Standard

|                               |                                      |   |
|-------------------------------|--------------------------------------|---|
| Effective Date:<br>07/01/2013 | <b>Excavation (Trenching) Safety</b> | Standard Number:<br><b>HSE 4100.040</b> |
| Supersedes:<br>04/01/2009     |                                      | Page 1 of 6                             |

Companies Affected:

|                                 |   |   |
|---------------------------------|---|---|
| <input type="checkbox"/> NIPSCO | <input checked="" type="checkbox"/> CGV | <input checked="" type="checkbox"/> CMD |
|                                 | <input checked="" type="checkbox"/> CKY | <input checked="" type="checkbox"/> COH |
|                                 | <input checked="" type="checkbox"/> CMA | <input checked="" type="checkbox"/> CPA |

**REFERENCE** 29 CFR 1926 Subpart P

### 1. PURPOSE

This document establishes the procedure for implementing and maintaining effective excavation safety work practices to prevent potential work-related injuries where the collapse of an excavation or trench wall could occur.

### 2. SCOPE

This document applies to all NiSource Companies when engaged in excavation (trenching) work activities.

### 3. RESPONSIBILITIES

All management, supervisors and employees that conduct work in or adjacent to an excavation share the responsibility to follow recognized safety work practices and shall be instructed as to the significance of the excavation safety work practices.

#### 3.1 Employees

Each employee has the responsibility to follow established work practices, enter an excavation only after receiving training and must demonstrate their understanding of the safe work practices including the use of personal protective equipment when working in an excavation.

For design purposes, NiSource shall classify soil as Soil Classification (Type) C only. This classification limitation provides for maximum protection for NiSource employees when sloping or shoring.

#### 3.2 Local Management

Local management in a department that conducts work involving excavations must designate a person or persons as a **Competent Person** and assure that these persons receive training prior to performing any excavation activity.

Local management must assure that a Competent Person performs the required duties and responsibilities at each excavation work site.

It is the responsibility of local management to ensure that all leaders/supervisors and

*This document is considered CONTROLLED only when viewed electronically on the Company's intranet. Printed or other electronic copies may not be current, and the intranet version should be used to verify.*



## Health, Safety and Environmental Standard

|                               |                                      |   |
|-------------------------------|--------------------------------------|---|
| Effective Date:<br>07/01/2013 | <b>Excavation (Trenching) Safety</b> | Standard Number:<br><b>HSE 4100.040</b> |
| Supersedes:<br>04/01/2009     |                                      | Page 2 of 6                             |

employees whose work involves being in or working adjacent to excavations are provided excavation safety training.

### 3.3 Competent Person

Each Competent Person at the excavation work site is responsible for ensuring that work practices described in this document and those work practices identified in local training programs are followed.

Excavation work may involve safety hazards not addressed by these work practices. It is the responsibility of the Competent Person to evaluate work site conditions and request guidance from local management if there are additional concerns for employee safety.

### 3.4 HSE Department

HSE Department's responsibilities include, but not limited to, the following.

- a. Monitoring the effectiveness of the excavation safety program through site assessments.
- b. Scheduling and providing employee training.

## 4. PROCEDURE

### 4.1 General Excavation Safety Work Practices

#### 4.1.1 Hazard Evaluation

An evaluation of work site hazards must be conducted by a Competent Person.

All hazards must be eliminated and/or controlled or employees must be provided appropriate personal protective equipment.

An inspection of the excavation shall be conducted by a Competent Person prior to initial entry, then daily and/or as conditions occur that may affect or create hazards.

#### 4.1.2 Damage Prevention

Other utility companies shall be notified in advance of opening any excavation in accordance with State one-call regulations and applicable Company standards. Underground infrastructure shall be appropriately located.





## Health, Safety and Environmental Standard

|                               |                                      |   |
|-------------------------------|--------------------------------------|---|
| Effective Date:<br>07/01/2013 | <b>Excavation (Trenching) Safety</b> | Standard Number:<br><b>HSE 4100.040</b> |
| Supersedes:<br>04/01/2009     |                                      | Page 3 of 6                             |

Utilities in the excavation must be protected and/or supported and precautions taken if any utility will be disturbed by the work.

When digging or probing in areas that may have buried electric lines that cannot be located, or are not exposed, the local (electric) utility company should be asked to expose their facilities or have a representative on site.

### 4.1.3 Traffic Control and Protection

Vehicular and pedestrian traffic around the site must be controlled. Barricades, signs, flag persons or other traffic control methods shall be used as needed. See HSE 4100.020 Work Zone Protection for additional requirements.

Department of Transportation load rated dock/bridge plates shall be used whenever an excavation in public roads or right of way is left open and unattended.

### 4.1.4 Protective Systems

A protective system shall be used whenever the depth of the excavation is five (5) feet or greater.

Protective systems for excavations less than five (5) feet in depth may be necessary when conditions, as determined by a Competent Person, warrant.

Manufacturers' tabulated data for pre-engineered protective systems or structures shall be followed and available at the work site when the systems are being used.

Pre-engineered protective systems installed by Company employees shall be inspected by a Competent Person prior to installation. Any deficiencies shall be corrected prior to use.

Company employees shall only install protective systems which they have been trained to install.

Protective systems installed by contractors shall be visually inspected by a Competent Person prior to entry by a Company employee.

### 4.1.5 Drainage Control

If excavation work interrupts the natural drainage of surface water (such as streams), diversion ditches, dikes or other water sources, suitable means shall be used to prevent water from entering the excavation and adequate drainage shall be maintained of the area adjacent to the excavation.



|                               |                                      |   |
|-------------------------------|--------------------------------------|---|
| Effective Date:<br>07/01/2013 | <b>Excavation (Trenching) Safety</b> | Standard Number:<br><b>HSE 4100.040</b> |
| Supersedes:<br>04/01/2009     |                                      | Page 4 of 6                             |

Water removal devices shall be monitored to ensure their continued operation.

#### **4.2 Contractors**

In the event the Company arranges for an outside contractor to perform work that requires Company employees to enter the excavation, the excavation shall be graded to a "Type C" soil and protected accordingly, or the Company employees shall not enter the excavation.

The contractor shall comply with the all applicable Federal, State and Local excavation safety laws and requirements.

#### **4.3 Accidents Regarding Excavation Safety**

The applicable leader/supervisor will be responsible for investigating all excavation accidents and reporting the cause of the accident to the local HS&E Manager.

### **5. TRAINING**

Training shall include the following topics as a minimum.

- a. Applicable requirements of the Occupational Safety and Health Administration's (OSHA) Excavation Standard (29 CFR 1926 Subpart P).
- b. Work site vehicular and pedestrian traffic controls.
- c. Methods of requesting locates from other underground utilities.
- d. Use of appropriate atmospheric monitoring equipment.
- e. Use of personal protective equipment at the excavation work site.
- f. Responsibilities and duties of a Competent Person.
- g. Assessing risks and hazards in and around the excavation.
- h. Inspection and use of the shoring equipment being utilized by the local operation.
- i. Company specific requirements and procedures.

Refresher training shall be conducted at least every three (3) years.

Additional retraining shall be conducted whenever a trend in the work practice assessments reveals, or whenever there is reason to believe, that there are deviations from or inadequacies in the employee's knowledge or use of the excavation safety work practices.

### **6. RECORDS**

All training sessions and dates of training shall be documented and recorded in the NiSource Learning Management System (LMS).



## Health, Safety and Environmental Standard

|                               |                                      |   |
|-------------------------------|--------------------------------------|---|
| Effective Date:<br>07/01/2013 | <b>Excavation (Trenching) Safety</b> | Standard Number:<br><b>HSE 4100.040</b> |
| Supersedes:<br>04/01/2009     |                                      | Page 5 of 6                             |

### 7. DEFINITIONS

**Cave-in** – The separation of a mass of soil or rock material from the side of an excavation, or the loss of soil from under a trench shield or support system, and its sudden movement into the excavation, either by falling or sliding, in sufficient quantity so that it could entrap, bury, or otherwise injure and immobilize a person.

**Competent Person** – One who is capable of identifying existing and predictable hazards in the surroundings, or working conditions that are unsanitary, hazardous, or dangerous to employees, and who has authorization to take prompt corrective measures to eliminate those hazards. A competent person should have and be able to demonstrate the following:

- Training, experience, and knowledge of: soil analysis, use of protective systems, and requirements of 29 CFR 1926 Subpart P.
- Ability to detect: conditions that could result in **cave-ins**, failures in protective systems, hazardous atmospheres, and other hazards including those associated with confined spaces.
- Authority to take prompt corrective measures to eliminate existing and predictable hazards and to stop work when required.

**Excavation** – Any man-made cut, cavity, trench, or depression in an earth surface, formed by earth removal.

**Hydraulic protective system** – A pre-engineered system comprised of hydraulic cylinders (cross braces used in conjunction with vertical rails (uprights) or horizontal rails (whalers)). Such a system is designed specifically to support the sidewalls of an excavation and prevent cave-ins.

**Pre-engineered protective system** - A hydraulic, pneumatic or shield system which protects workers from an excavation or trench cave-in.

**Registered Professional Engineer** – A person who is registered as a professional engineer and working within a discipline applicable to excavation work.

**Shield (shield system)** – A pre-engineered structure that is able to withstand the forces imposed on it by a cave-in and thereby protects employees within the structure. Shields can be permanent structure or can be designed to be portable and moved along as work progresses. Also known as a trench box or trench shield.

**Shoring (shoring system)** – A structure such as a metal hydraulic, mechanical or timber shoring system that supports the sides of an excavation and which is designed to prevent cave-ins.

**Sloping (sloping system)** – A method of protecting employees from cave-ins by excavating to form sides of an excavation that is inclined away from the excavation so as to prevent



## Health, Safety and Environmental Standard

|                               |                                      |   |
|-------------------------------|--------------------------------------|---|
| Effective Date:<br>07/01/2013 | <b>Excavation (Trenching) Safety</b> | Standard Number:<br><b>HSE 4100.040</b> |
| Supersedes:<br>04/01/2009     |                                      | Page 6 of 6                             |

cave-ins. The angle of incline varies with differences in such factors as the soil type, environmental conditions of exposure, and application of surcharge loads. Sloping methods shall be identified by a Competent Person.

**Trench (trench excavation)** – A narrow excavation (in relation to its length) made below the surface of the ground. In general, the depth is greater than the width, but the width of a trench is not greater than 15 feet. If forms or other structures are installed or constructed in an excavation as to reduce the dimension measured from the forms or structure to the side of the excavation to 15 feet or less, the excavation is also considered to be a trench.

**Trench Box** – See Shield.

**Trench Shield** – See Shield.



Distribution Operations

Health, Safety and Environmental Standard

|                               |   |   |
|-------------------------------|---|---|
| Effective Date:<br>10/15/2014 | <b>Tools and Equipment - Plant<br/>Operations</b> | Standard Number:<br><b>HSE 4100.050</b> |
| Supersedes:<br>N/A            |   | Page 1 of 10                            |

Companies Affected:

|                                 |   |   |
|---------------------------------|---|---|
| <input type="checkbox"/> NIPSCO | <input type="checkbox"/> CGV            | <input checked="" type="checkbox"/> CMD |
|                                 | <input checked="" type="checkbox"/> CKY | <input checked="" type="checkbox"/> COH |
|                                 | <input checked="" type="checkbox"/> CMA | <input checked="" type="checkbox"/> CPA |

**REFERENCE** Code of Federal Regulations - Title 49 - Part 192 - § 192.605  
National Electric Code  
OSHA 1926 Subpart I

**1. HAND TOOLS**

Significant numbers of disabling industrial injuries are caused by improper use of hand tools. Hand tool accidents can largely be eliminated by following these safety practices.

- a. Use only tools in good condition. Striking tools with mushroomed heads, handles that are cracked, broken or loose, and wrenches with worn or bent jaws shall be repaired or replaced.
- b. Use the proper tool for the job. Do not substitute a wrench for a hammer, a screwdriver for a chisel, etc.
- c. Use tools properly. Wrenches should be pulled, not pushed; the head of the hammer, not the side, should be used as the striking surface, etc.
- d. Keep tools clean and stored properly. Tools shall be returned to their proper storage place and not be allowed to lie around where they could cause personal injury. Exercise due care when transporting or storing sharp or pointed tools.
- e. All portable powered hand tools shall be equipped with a constant pressure switch or control and may have a lock-on control provided that turn off can be accomplished by a single motion of the same finger or fingers that turn it on.
- f. Electric power operated tools shall either be of the double-insulated type or grounded with a three prong plug.
- g. Electric power operated tools shall not be used in an area when the operation of the tool will produce sparking that can cause ignition when a gaseous atmosphere is present or can be introduced.
- h. When tools are equipped with safety devices, the safety devices are not to be removed or disabled.

**2. PNEUMATIC TOOLS**

Personal protective equipment, as specified in the HSE 4200 series of procedures shall be used when operating a pneumatic tool.

*This document is considered CONTROLLED only when viewed electronically on the Company's intranet. Printed or other electronic copies may not be current, and the intranet version should be used to verify.*



**Distribution Operations**

**Health, Safety and Environmental Standard**

|                               |   |   |
|-------------------------------|---|---|
| Effective Date:<br>10/15/2014 | <b>Tools and Equipment - Plant<br/>Operations</b> | Standard Number:<br><b>HSE 4100.050</b> |
| Supersedes:<br>N/A            |   | Page 2 of 10                            |

All hose connections to a pressurized source except connections to pipeline facilities, shall be secured with a positive locking device or threaded connection. In addition, a physical hose restraint must be used with positive locking devices. The restraint (Exhibit A) shall be installed to prevent the hose from becoming a striking hazard should the positive locking device fail.

Manufacturers of physical hose restraint will have installation instruction for using physical hose restraint with tools. Some make a different model for hose to tool connections. These instructions shall be followed when making hose to tool connections. These may include using the bare loop through one of the siderods on the barrel of the tool and then back through itself (choker). The spring end then attaches onto the air hose behind the coupler, or simply using one end on the tool handle and the other end on the hose.

When using a Hole Hog, a physical hose restraint must remain in place from the air source to the hole hog until it is inserted into its departure hole. The physical hose restraint shall not hinder the operation of the hole hog. An example of this is:

Once the hole hog has been leveled, energized and is properly inserted into the insertion hole, the air shall then be de energized, physical hose restraint removed, air hose reconnected and then reenergized with the employee above the excavation. This would eliminate any possible binding or hindering the hole hog from potentially getting stuck on an object in reverse.

Compressed air shall never be directed at anyone.

Hoses, couplings, connectors, flow-check valves and tools are to be maintained in working condition. Portable compressors shall be inspected in accordance with manufacturer's instructions.

Blast cleaning nozzles shall be equipped with an operating valve which must be held open manually (deadman control). The nozzle shall not be placed directly on the ground when not in use. The nozzle shall be placed in a clean area where the operating valve cannot be accidentally operated.

When possible, connect the air hose to the rear or curb side of the portable compressor, so it is not exposed to traffic.

If possible, keep the air hose off the sidewalk to avoid a tripping hazard to the public, and out of traffic lanes to avoid its entangling with or being run over by passing vehicles.

Compressor air supply valves shall be located upstream of the supply air hoses. When more than one air supply outlet is available on a compressor, a control valve shall be provided for each outlet. Valves to the unused air outlets shall be turned off. Do not attempt to work loose or pull out a jammed breaker bit.

Remove the jammed bit from the tool, insert another bit and cut the jammed bit loose.



**Health, Safety and Environmental Standard**

**Distribution Operations**

|                               |   |   |
|-------------------------------|---|---|
| Effective Date:<br>10/15/2014 | <b>Tools and Equipment - Plant Operations</b> | Standard Number:<br><b>HSE 4100.050</b> |
| Supersedes:<br>N/A            |   | Page 3 of 10                            |

When the tool is not in use, it shall be placed in such a position that the likelihood of falling or accidental triggering is minimized.

When the use of a pneumatic tool is no longer required, close the air outlet valve, bleed the hose, disconnect the tool, clean and inspect the tool, and return tool to its proper storage location. For tools requiring oiling, pour a few ounces of the appropriate lubricant (see Table below) into the tool's air inlet and operate 10 to 15 seconds before storing.

**LUBRICATION TABLE**

| <u>TOOL</u>             | <u>LUBRICANT</u>                          | <u>FLUSH</u>                 | <u>DE-ICER</u>          |
|-------------------------|---|------------------------------|-------------------------|
| Hole Hog                | 2 oz. Type 'A' Transmission Fluid         | N/R                          | Dry-Gas/<br>Alcohol     |
| PneumaGopher            | 2 oz. Type 'A' or 'F' Transmission Fluid* | 2 oz. Penetrate<br>Then Lube | Anti-Freeze/<br>Alcohol |
| Breaker<br>(Air Hammer) |   |                              |                         |
| Spade (Digger)          |   |                              |                         |
| Rock Drill<br>(Rotor)   | Air-Tool Oil or 10w Motor Oil             | 2 oz. Kerosene<br>Then Lube  | Dry-Gas/<br>Anti-Freeze |
| Tamper                  |   |                              |                         |
| Reamer                  |   |                              |                         |
| <u>Water Pump</u>       |   |                              |                         |

\*Must be also used with Schramm line oiler.

Each portable air compressor shall be equipped with a permanently affixed excess flow valve and a 3/4 inch supply air hose. When an inline oiler is used, a 15 foot length maximum of 3/4 inch "connecting" hose (Exhibit B) is required.

Note: No oil, solvents, antifreeze, or any other foreign substance shall be introduced into the hoses.

Most Company acquired pneumatic tools requiring oiling (i.e., breakers, tampers, rock drills, etc.) have internal oil reservoirs. This reservoir shall be checked and filled prior to each use. If the internal reservoir is not utilized or if the pneumatic tool is not so equipped, then an inline oiler as illustrated on Exhibit B shall be used. Using an inline oiler requires a separate "connecting" hose since the "connecting" hose will become contaminated with oil, etc.



**Distribution Operations**

**Health, Safety and Environmental Standard**

|                               |   |   |
|-------------------------------|---|---|
| Effective Date:<br>10/15/2014 | <b>Tools and Equipment - Plant<br/>Operations</b> | Standard Number:<br><b>HSE 4100.050</b> |
| Supersedes:<br>N/A            |   | Page 4 of 10                            |

If the operation of the tool becomes sluggish, flush with Kerosene as indicated in Table above, except for hole hogs which must be disassembled and cleaned. If the tool freezes up in cold weather, pour de-icer into the air inlet of tool, see Table above.

Open ends of supply air and "connecting" hoses should be capped or protected when not in use to prevent entry of dirt.

**3. HYDRAULIC TOOLS**

Personal protective equipment, as specified in the HSE 4200 series of procedures shall be used when operating hydraulic tools.

Hoses, couplings and tools are to be maintained in working condition.

If possible, keep the hydraulic hose off the sidewalk to avoid a tripping hazard to the public, and out of traffic lanes to avoid its entangling with or being run over by passing vehicles.

When two separate tools are operated from a dual system hydraulic power unit, care shall be taken to properly set the controlling flow valve for each tool circuit.

Do not attempt to work loose or pull out a jammed breaker bit. Remove the jammed bit from the tool, insert another bit and cut the jammed bit loose.

When the tool is not in use, it shall be placed in such a position that the likelihood of falling or accidental triggering is minimized.

When the use of a hydraulic tool is no longer required, close the tool circuit supply valve, disconnect the tool, clean and inspect the tool, place dust cap on all fittings, and return it to its proper storage location.

**4. WORKING WITH HEAVY EQUIPMENT**

Qualified employees shall operate heavy equipment, such as large trucks, bulldozers, trenching machines, backhoes, boring machines, etc. and be responsible for its safe operation.

When transporting excavation equipment on trailers, the bucket or scoop shall be free of unsecured material, tools, spoil, gravel, etc.

When working around heavy equipment, stand clear of suspended loads, winch lines, booms, buckets or any other part of the machinery that can swing or drop. Onlookers should be kept clear of equipment.

Excavating machinery not in use shall have the blade, bucket or scoop lowered to the ground or set to rest in its cradle. The operator shall shut off the engine and remove the ignition key when not at the controls. A machine left unattended shall be locked when practical, so that unauthorized persons cannot start it.



**Distribution Operations**

**Health, Safety and Environmental Standard**

|                               |   |   |
|-------------------------------|---|---|
| Effective Date:<br>10/15/2014 | <b>Tools and Equipment - Plant<br/>Operations</b> | Standard Number:<br><b>HSE 4100.050</b> |
| Supersedes:<br>N/A            |   | Page 5 of 10                            |

An unattended truck shall have its engine shut off, be in low, reverse, or park gear position, and have its parking brake set or have its wheels chocked. Ignition keys shall be removed.

Precaution shall be taken to prevent accidental movement of equipment parked on grades, such as chocking, lowering stabilizers, blade, etc.

Seat belts shall be worn when operating equipment which has rollover protection. They shall not be worn when operating equipment which does not have rollover protection.

No riders are permitted on equipment not designed for passengers.

Extreme care shall be exercised when operating boom type equipment in the vicinity of overhead wires.

Machinery should be shut down while being serviced. If the machinery must be operational during servicing, caution shall be exercised.

**5. THERMIT WELDING EQUIPMENT**

Personal protective equipment, as specified in the HSE 4200 series of procedures shall be used when performing the thermit weld process.

When making a thermit weld, the thermit charge, mold and pipe surface to which the weld is being made shall be dry. If any one of the components is damp or wet, the thermit joining material can erupt violently when ignited.

Charges and molds shall be stored in a dry location and shall not be placed on damp or wet surfaces, such as wet grass, when being used. The lid of the thermit mold shall be closed before igniting the thermit charge.

Refer to GS 1420.580 "Thermite Weld Process" for detail instructions for making a thermit weld.

**6. GENERATORS**

Each portable or vehicle-mounted generator used for operations shall have ground fault circuit interruption (GFCI) protection for its 120 volt outlets. Generators purchased for use in the future shall be specified with 120 volt GFCI outlets. Existing generators that do not already have 120 volt GFCI protected outlets will be retrofitted.

The GFCI's should be tested each day the generator is used to assure they are properly functioning prior to operating any electrical equipment to be protected by them.

Earth grounding of portable or vehicle-mounted generators is not required. However, the generator frame for vehicle-mounted generators should be bonded to the vehicle frame.

Refer to the manufacturer's instructions for operating and maintenance requirements.





**Distribution Operations**

**Health, Safety and Environmental Standard**

|                               |   |   |
|-------------------------------|---|---|
| Effective Date:<br>10/15/2014 | <b>Tools and Equipment - Plant<br/>Operations</b> | Standard Number:<br><b>HSE 4100.050</b> |
| Supersedes:<br>N/A            |   | Page 6 of 10                            |

**7. WORK SITE LIGHTING**

Work Site Lighting systems normally consist of three components as follows:

- a. light source
- b. power cable
- c. power source

The light source shall be explosion proof (Class 1, Division 1) in order for it to function in any environment. The wiring on the stanchion and cross-arms shall be in sealed conduit.

The power cable shall be heavy duty. Care shall be taken to position the cable in a manner that will lessen the chances of the cable being cut or damaged.

The power source, which is normally a generator, is the prime source of ignition in an explosive environment. Therefore, the power source shall be placed up wind of the work site at a safe distance from a possible gaseous atmosphere.

To avoid an accidental ignition, the final power cable connection or switch operation shall be made in an area that is gas free.

**8. NON-OPERATIONAL EQUIPMENT**

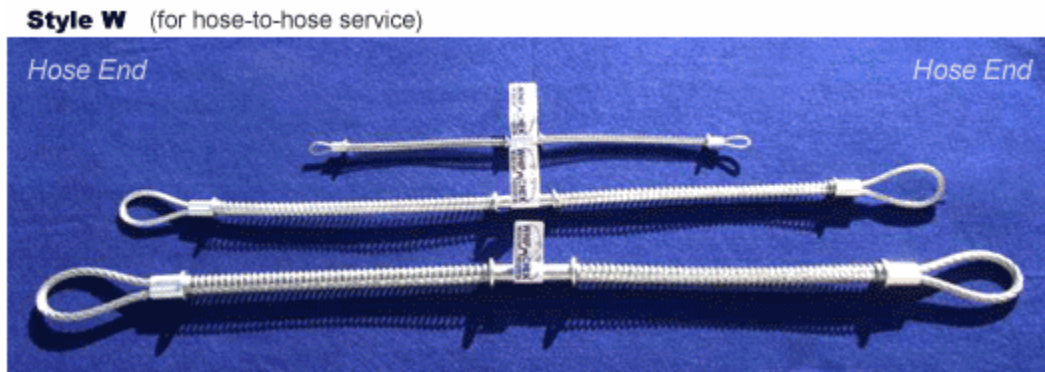
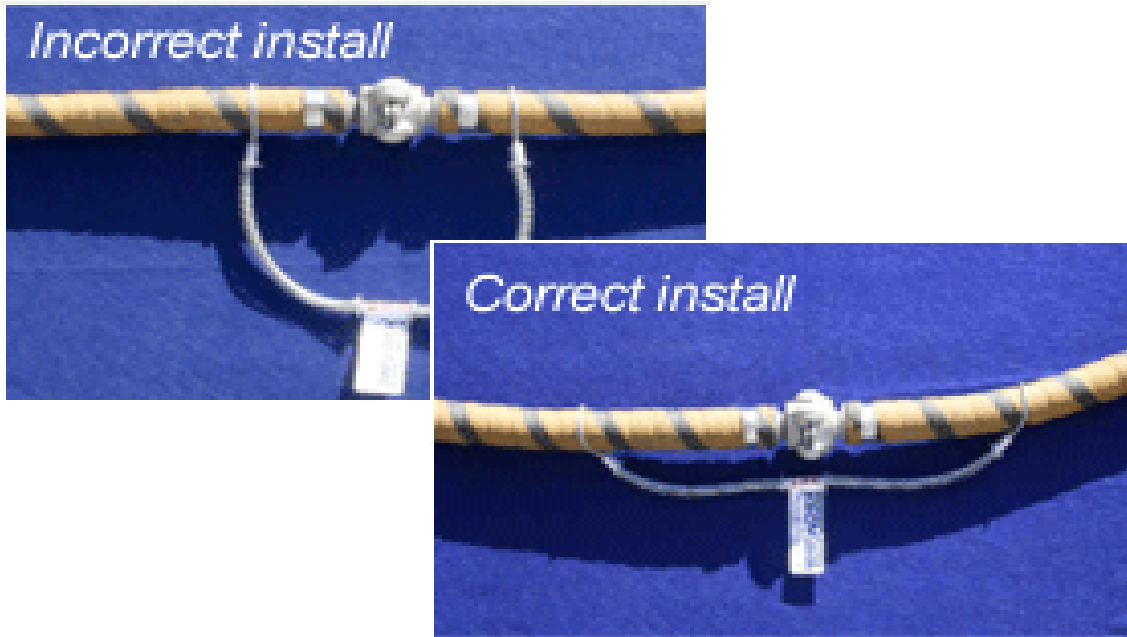
Tools and equipment that are non-operational, meaning in need of repair or possibly defective, shall be tagged to indicate that they shall not be used. Form HSE 4100.050-1, Exhibit C, "Do Not Operate" tag shall be used to tag such tools or equipment.

Defective tools and equipment shall be reported in accordance with GS 1652.010 "Investigation of Failures."

|                               |   |   |
|-------------------------------|---|---|
| Effective Date:<br>10/15/2014 | <b>Tools and Equipment - Plant Operations</b> | Standard Number:<br><b>HSE 4100.050</b> |
| Supersedes:<br>N/A            |   | Page 7 of 10                            |

**EXHIBIT A  
(1 OF 2)**

**EXAMPLES OF PHYSICAL HOSE RESTRAINT AND CORRECT INSTALLATION**





Distribution Operations

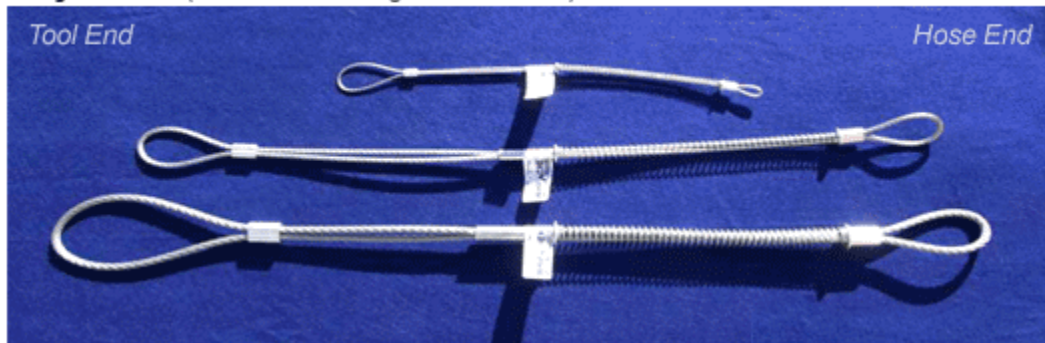
Health, Safety and Environmental Standard

|                               |   |   |
|-------------------------------|---|---|
| Effective Date:<br>10/15/2014 | <b>Tools and Equipment - Plant<br/>Operations</b> | Standard Number:<br><b>HSE 4100.050</b> |
| Supersedes:<br>N/A            |   | Page 8 of 10                            |

**EXHIBIT A  
(2 OF 2)**

**EXAMPLES OF PHYSICAL HOSE RESTRAINTS AND CORRECT INSTALLATION  
(continued)**

**Style WSR** (for hose-to-tool / rigid outlet service)

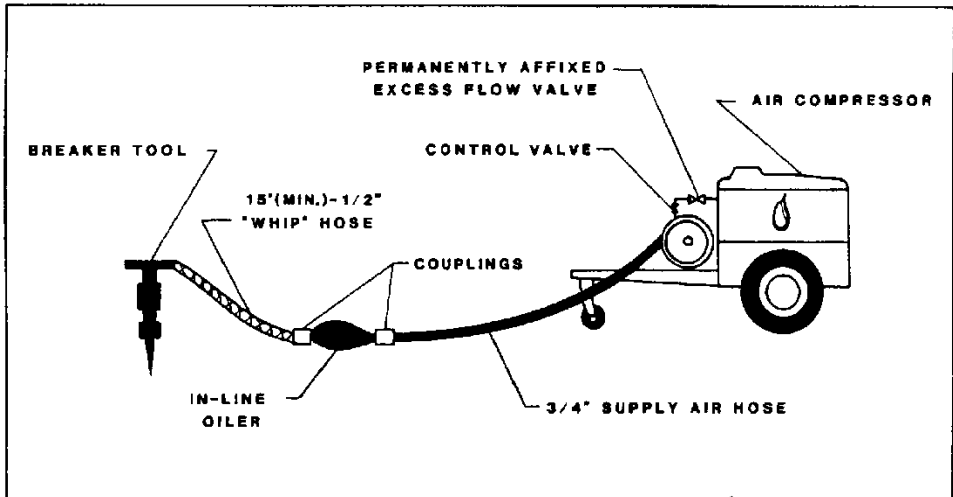


|                               |   |   |
|-------------------------------|---|---|
| Effective Date:<br>10/15/2014 | <b>Tools and Equipment - Plant Operations</b> | Standard Number:<br><b>HSE 4100.050</b> |
| Supersedes:<br>N/A            |   | Page 9 of 10                            |

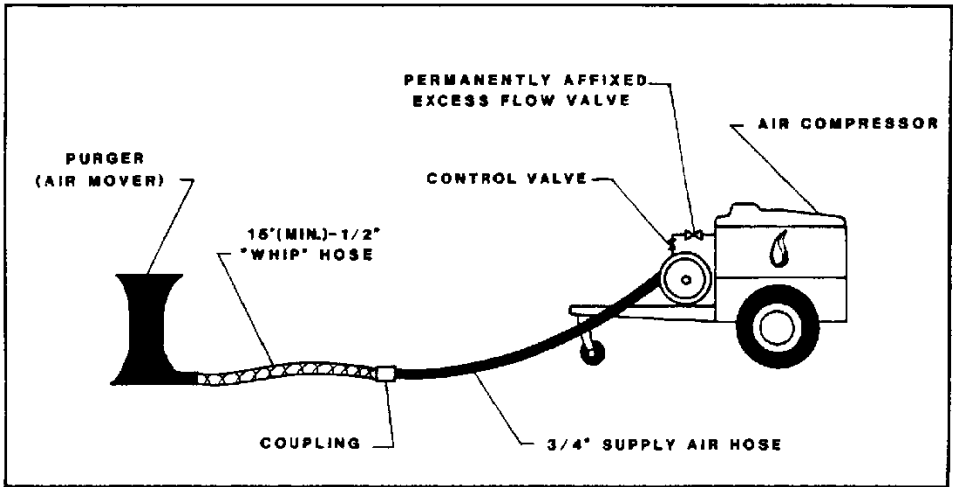
**EXHIBIT B**

**TYPICAL ARRANGEMENT FOR PNEUMATIC TOOLS**

**UTILIZING AN INLINE OILER**



**NOT REQUIRING AN OILER**





**Distribution Operations**

**Health, Safety and Environmental Standard**

|                               |   |   |
|-------------------------------|---|---|
| Effective Date:<br>10/15/2014 | <b>Tools and Equipment - Plant<br/>Operations</b> | Standard Number:<br><b>HSE 4100.050</b> |
| Supersedes:<br>N/A            |   | Page 10 of 10                           |

**EXHIBIT C**





**Distribution Operations**

**Health, Safety and Environmental Standard**

|                               |  |  |
|-------------------------------|--|--|
| Effective Date:<br>10/07/1988 | <b>Handling, Storing, Transporting<br/>and Disposal of Mercury</b> | Standard Number:<br><b>HSE 4100.060(CG)</b><br>P&P 435-4 |
| Supersedes:<br>N/A            |  | Page 1 of 9  |

Companies Affected:

|                                     |   |   |
|-------------------------------------|---|---|
| <input type="checkbox"/> NIPSCO     | <input checked="" type="checkbox"/> CGV | <input checked="" type="checkbox"/> CMD |
| <input type="checkbox"/> NIFL       | <input checked="" type="checkbox"/> CKY | <input type="checkbox"/> COH            |
| <input type="checkbox"/> Kokomo Gas | <input type="checkbox"/> CMA            | <input checked="" type="checkbox"/> CPA |

**REFERENCE** Code of Federal Regulations - Title 29 - Part 1910 - Code of Federal Regulations - Title 40 - Part 262 - Code of Federal Regulations - Title 49 - Part 171-177

**1. PLANS HEALTH EFFECTS**

**1.1 Exposure**

Exposure to mercury may be in liquid or vapor form. Mercury is unique in that it is the only metal which is a liquid at room temperature. When liquid mercury is exposed to air, it produces an odorless and colorless vapor. Vaporization takes place more rapidly as temperature increases. Vaporization also takes place more rapidly if the mercury is agitated because mercury gradually forms a film of impurities on areas exposed to air which slows down the vaporization process if left undisturbed. Mercury can enter the body through the lungs, skin, and digestive system; but breathing the vapor is the most common cause of mercury poisoning.

The permissible exposure limit of employees to mercury vapors is currently 0.05 milligrams per cubic meter of air on an 8 hour time weighted average. Under normal conditions, Plant/Service personnel would not be exposed to mercury vapors at levels approaching the permissible exposure limit.

**1.2 Symptoms**

Overexposure to mercury by employees is highly unlikely. However, the following symptoms are given for information purposes only:

- a. tremors of the hands
- b. reddening of the gums
- c. nervous – irritable
- d. sudden and continuous loss of weight
- e. heavy perspiration

Employees who have had continuous exposure to mercury, either by inhalation of mercury vapors or by absorption through the skin, and show evidence of one or more

*This document is considered CONTROLLED only when viewed electronically on the Company's intranet. Printed or other electronic copies may not be current, and the intranet version should be used to verify.*



**Distribution Operations**

## Health, Safety and Environmental Standard

|                               |  |  |
|-------------------------------|--|--|
| Effective Date:<br>10/07/1988 | <b>Handling, Storing, Transporting<br/>and Disposal of Mercury</b> | Standard Number:<br><b>HSE 4100.060(CG)</b><br>P&P 435-4 |
| Supersedes:<br>N/A            |  | Page 2 of 9  |

of the above symptoms will be provided with medical screening examinations by a qualified physician. Medical records shall be maintained as required by OSHA for a period of 30 years after employment [NiSource corporate procedure "Access to Medical Records"].

### 2. HANDLING MERCURY

Mercury shall be handled with extreme care to avoid spillage and accidental exposure. Work areas in which mercury is poured, drained, or used in any manner shall be well ventilated. When transferring mercury into a container a catch basin shall be placed beneath the container to collect any spills. Any employee handling mercury shall wear plastic gloves. Other protective equipment shall be used, as directed by the District Health and Safety specialist. Personal effects such as rings, watches, coins, wallets, and combs shall be kept where direct contact with mercury will be avoided.

Areas of skin in direct contact with liquid mercury should be washed immediately with soap and water or other suitable cleaning agents. In order to avoid accidental ingestion of mercury, employees in close contact with mercury should wash their hands before eating, drinking, using tobacco products, applying cosmetics, or any other activity in which mercury could possibly contact the mouth. Employees shall wash hands before contacting the eyes for any reason and before using toilet facilities.

### 3. COLLECTING MERCURY

Mercury collected during the day shall be transported in properly labeled plastic bottles not exceeding 8 fluid oz. (refer to Material Catalog Page No. IX-32) with lids tightly closed. The bottles shall be carried inside of a container capable of containing the contents of the bottle and protecting the bottle from damage. The container shall be secured to prevent shifting during transport. Mercury and mercury containing objects shall not be placed in the passenger area of the vehicle. Mercury collected during the day shall be transferred to a warehouse storage bottle as soon as practical.

### 4. STORING MERCURY

Mercury shall be stored in warehouses or other similar facilities under the following conditions:

- a. away from heat sources
- b. areas with limited access
- c. at or near to floor level
- d. with visible signs reading "CAUTION - MERCURY STORAGE AREA, NO EATING OR SMOKING."





Distribution Operations

Health, Safety and Environmental Standard

|                               |  |  |
|-------------------------------|--|--|
| Effective Date:<br>10/07/1988 | <b>Handling, Storing, Transporting<br/>and Disposal of Mercury</b> | Standard Number:<br><b>HSE 4100.060(CG)</b><br>P&P 435-4 |
| Supersedes:<br>N/A            |  | Page 3 of 9  |

Storage containers shall consist of properly labeled polyethylene laboratory bottles and screw caps with heavy duty threads and wide openings for easy pouring. (Refer to Material Catalog Page No. IX-32.) Because mercury is very dense (1.1 fl. oz. = 1 lb), bottle sizes shall not exceed 16 oz. as large bottles become difficult to handle safely. The bottles shall be replaced when they become discolored and brittle. Areas which accumulate mercury rapidly should use a mercury flask (fill weight approximately 85 pounds) to safely store larger quantities of mercury in order to avoid storing more than one 16 oz. storage bottle.

**5. DISPOSAL OF MERCURY**

Once a 16 oz. storage bottle or mercury flask is filled, the cap shall be sealed with tape. The warehouseman or other employee responsible for storing the mercury shall arrange for transport to a centralized collection point. Mercury collected at the centralized collection point shall be stored in a mercury flask(s). The emptied bottles may be reused as needed. The mercury shall be ultimately transported to a mercury recycling company designated by the Manager of Codes, Regulations, and Environmental.

**6. DESIGN OF STORAGE AREAS**

Mercury shall be poured or drained only over surfaces which are non-porous (ceramic, steel, glass), are free of cracks, and have collection trays suitable for containment of accidental spills.

Floors in laboratories, gauge calibration areas, or similar type rooms in which mercury is utilized shall be smooth and of non porous material with all joints in the flooring and areas between the baseboards and flooring free of cracks. It is recommended that sheet linoleum or vinyl with the joints sealed and the edges coved at the wall be used in these locations.

**7. REMOVAL OF MERCURY SEAL REGULATORS**

The greatest exposure to mercury by employees is the removal of mercury seal regulators. Mercury seal regulators are identifiable by a characteristic cup which is located on the underside of the regulator (Exhibit A).

When a mercury seal regulator is identified, and removal is required, the employee must make a determination as to which method of removal is the safest and will minimize exposure of the customer and employee from accidental spills.

The cup may be removed, at the premises, if it can be easily accomplished and access does not present a problem. While the cup is being removed, a container such as a polyethylene bucket shall be placed directly beneath the regulator in order to contain any accidental spills. After the cup is removed, the mercury shall be poured into the storage bottle as near to the ground as possible but directly over the bucket. Once the mercury is in the storage bottle, the cup may be replaced, and the regulator removed from the premises. Before transporting the regulator, the vent and openings shall be plugged and remain plugged during disposal.





**Distribution Operations**

**Health, Safety and Environmental Standard**

|                               |  |  |
|-------------------------------|--|--|
| Effective Date:<br>10/07/1988 | <b>Handling, Storing, Transporting<br/>and Disposal of Mercury</b> | Standard Number:<br><b>HSE 4100.060(CG)</b><br>P&P 435-4 |
| Supersedes:<br>N/A            |  | Page 4 of 9  |

When the cup can not be easily removed or is inaccessible, the vent shall be plugged with a steel plug before the regulator is removed. Immediately after removal, the inlet and outlet openings shall be plugged using a plastic cap or steel plug. The regulator shall be placed in a plastic bag and removed from the premises. A label affixed to the bag shall identify the contents as containing mercury with a warning label. A label reading "CONTAINS MERCURY, DO NOT OPEN, VAPORS MAY BE HARMFUL IF INHALED" will be sufficient warning to unauthorized personnel. Labels may be handwritten, however, districts which encounter mercury seal regulators on a regular basis may wish to develop a standardized label. The regulator may be taken to a work area described in Section 6 where the mercury can be properly removed by employees with protective equipment.

After removal of mercury from the regulator, the regulator may be disposed of as ordinary junk.

**8. MONITORING MERCURY VAPOR LEVELS**

**8.1 Manned Facilities**

Each manned facility (including laboratories, meter shops, and vehicles) which may be exposed to mercury contamination shall be monitored on an annual basis.

**8.2 Unmanned Facilities**

Each facility not normally occupied shall be monitored after a spill report has been submitted and also after remedial action has been completed to clean up the spill.

**8.3 Mercury Vapor Level Survey Report**

Form CS 7-127, "Mercury Vapor Level Survey Report" (Exhibit B) shall be used to record and report mercury vapor level surveys. A copy of this form is to be retained at the work location having jurisdiction over the facility to which the survey relates. A report or letter summarizing the reports or letters made during the last 12 months is to be sent to the District Manager or Department Head with a copy to the Human Resources, Safety Manager by October 1 of each year.

**8.4 Mercury Inspection Survey Procedure**

The ambient temperature should be 55° or greater prior to conducting mercury inspection surveys.

Employees using a mercury vapor detector or a mercury vacuum cleaner shall be familiar with their operation.

Each area to be surveyed shall be checked for the presence of combustible gas where the presence of hydrocarbons are suspected, using an approved Gas Detector, before



Distribution Operations

## Health, Safety and Environmental Standard

|                               |  |  |
|-------------------------------|--|--|
| Effective Date:<br>10/07/1988 | <b>Handling, Storing, Transporting<br/>and Disposal of Mercury</b> | Standard Number:<br><b>HSE 4100.060(CG)</b><br>P&P 435-4 |
| Supersedes:<br>N/A            |  | Page 5 of 9  |

the mercury detector is used. This is necessary for two reasons:

1. The mercury detector might ignite a combustible mixture of gas and air.
2. The ultraviolet absorption type mercury detector will produce an erroneous reading in a hydrocarbon polluted atmosphere.

If it has determined a hydrocarbon source is present, it shall be eliminated or removed by cleaning, ventilation, or other measures as appropriate prior to testing.

### 9. SPILLS AND CLEAN UP

#### 9.1 Notification

In the event of a spill, the employee is to immediately notify the supervisor, who will in turn notify the Division and District Health and Safety Specialist of the incident. Spills greater than 1 pound are to be reported in accordance with [HSE 4400.020\(CG\)](#) "Environmental Occurrence Reporting."

#### 9.2 Small Spills

Spills in which a few beads of mercury are confined to a small area with easy access may be cleaned up using an aspirator bulb or similar suction instrument. The area shall be monitored for mercury vapor levels using a vapor detector. If mercury vapor levels exceed 0.05 milligrams per cubic meter of air, further cleanup will be necessary using a mercury vacuum cleaner and mercury cleaners described in the next Section.

Note: Dry sweeping, blowing with compressed air, and shaking of contaminated articles is prohibited because these measures only scatter the mercury and cause it to vaporize more rapidly. Use of clothing, rags, paper towels, etc. for cleanup is also prohibited for they absorb and scatter mercury.

#### 9.3 Larger Spills

With larger spills, a more comprehensive approach is required to successfully clean up the spill with minimal employee exposure. A mercury vapor detector should be used to determine the extent of the spill. Areas where the mercury vapor concentration is greater than 0.05 milligram per cubic meter of air should be isolated. Note: Mercury

vapors are heavier than air and will collect in areas close to the ground. Employees working in the contaminated area should have their footwear checked for contamination before leaving the contaminated area.

A mercury vacuum cleaner is available from the Safety Department and should be used in conjunction with the mercury vapor detector in order to find the mercury and



**Distribution Operations**

**Health, Safety and Environmental Standard**

|                               |  |  |
|-------------------------------|--|--|
| Effective Date:<br>10/07/1988 | <b>Handling, Storing, Transporting<br/>and Disposal of Mercury</b> | Standard Number:<br><b>HSE 4100.060(CG)</b><br>P&P 435-4 |
| Supersedes:<br>N/A            |  | Page 6 of 9  |

remove it. Note the prohibited clean up methods mentioned at the end of Section 9.2. Employees shall wear protective equipment provided by the Company if exposure to mercury is likely. If mercury vapor levels still exceed the acceptable threshold limit mentioned earlier, a mercury clean up kit containing HgX or other absorbent powders may be used (refer to Material Catalog Page No. VII-38). Note: HgX vapors are highly corrosive and should not be used on metal surfaces or in the vicinity of metal objects susceptible to corrosion.

Before cleanup of a large spill, the hiring of an outside contractor should be considered.

**10. DISPOSAL OF MERCURY CONTAMINATED WASTE**

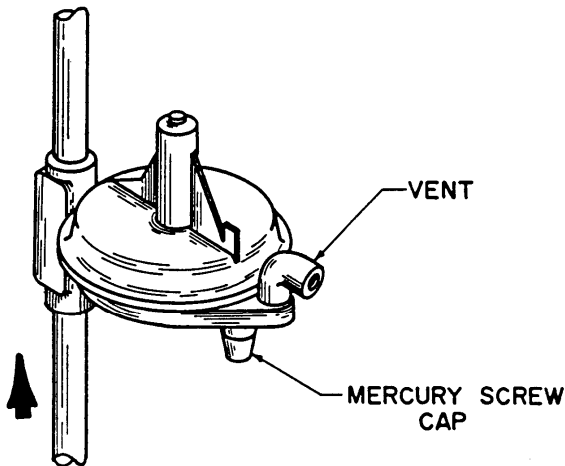
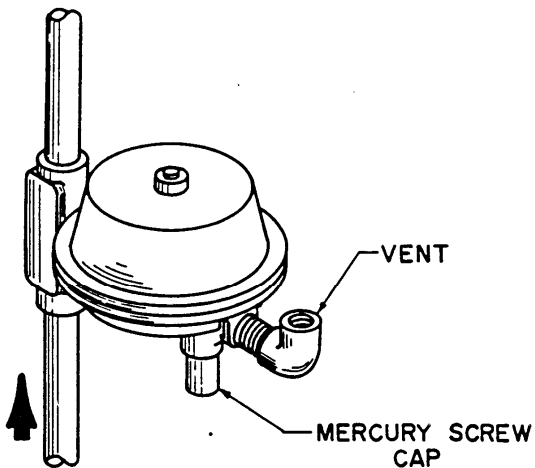
Mercury contaminated waste shall be stored in a properly labeled DOT approved container. The size of the container will depend on the amount of waste. In most cases a DOT Class 17C 55 gallon steel drum (open top) with a bolt ring assembly for tight closure or a DOT Class 17E (closed top) will be used. Adsorbents should be used if liquid mercury is moving freely inside of the container. Once the mercury is immobilized, the containers may be sealed, properly labeled, and prepared for transport. The sealed drums shall be stored in a well ventilated area (preferably outdoors), with limited access, and on wooden blocks or similar object which allows ventilation beneath the drum in order to prevent corrosion.

The Manager of Codes, Regulations, and Environmental shall be contacted for disposal instructions.

|                               |  |  |
|-------------------------------|--|--|
| Effective Date:<br>10/07/1988 | <b>Handling, Storing, Transporting<br/>and Disposal of Mercury</b> | Standard Number:<br><b>HSE 4100.060(CG)</b><br>P&P 435-4 |
| Supersedes:<br>N/A            |  | Page 7 of 9  |

**EXHIBIT A**

TYPICAL MERCURY SEAL REGULATORS





Distribution Operations

Health, Safety and Environmental Standard

|                               |  |  |
|-------------------------------|--|--|
| Effective Date:<br>10/07/1988 | <b>Handling, Storing, Transporting<br/>and Disposal of Mercury</b> | Standard Number:<br><b>HSE 4100.060(CG)</b><br>P&P 435-4 |
| Supersedes:<br>N/A            |  | Page 8 of 9  |

**EXHIBIT B  
(1 OF 2)**

Instructions for completion of Form CS7-127, "Mercury Vapor Level Survey Report".

The following items are keyed to Form CS7-127 page 2, this Exhibit.

| <u>Key</u> | <u>Item</u>                          | <u>Description</u>   |
|------------|--------------------------------------|--|
| 1.         | Location                             | Provide location of area inspected   |
| 2.         | Date                                 | Self-explanatory   |
| 3a.        | Initial Reading...                   | Provide sufficient readings to determine extent of contamination   |
| 3b.        | Specific Location                    | Provide a sketch, as appropriate to identify the location of each reading of Key 3a. Location should include:<br><br>Height of reading in relationship to the floor<br><br>Distance from area where employee works<br><br>A reading at the normal breathing height of employee<br><br>Distance from location where mercury is stored |
| 4.         | Ambient Temperature                  | Self-explanatory<br>Note: To obtain valid readings the ambient temperature should be 55°F or greater   |
| 5.         | Describe action taken                | Describe measures and actions taken to isolate and clean up spill  |
| 6.         | By.                                  | Name of person conducting survey   |
| 7.         | Retest Date                          | Self-explanatory   |
| 8.         | Retest Reading and Specific location | Retest reading shall be taken at all location's recorded under Key 3b above  |
| 9.         | Ambient Temperature                  | See Key 4 above  |
| 10.        | Retest By.                           | Self explanatory   |



Distribution Operations

Health, Safety and Environmental Standard

|                               |  |  |
|-------------------------------|--|--|
| Effective Date:<br>10/07/1988 | <b>Handling, Storing, Transporting<br/>and Disposal of Mercury</b> | Standard Number:<br><b>HSE 4100.060(CG)</b><br>P&P 435-4 |
| Supersedes:<br>N/A            |  | Page 9 of 9  |

**EXHIBIT B  
(2 OF 2)**

FORM CS 7-127 CSD

COLUMBIA GAS SYSTEM  
MERCURY VAPOR LEVEL SURVEY REPORT  
TOXIC THRESHOLD - 0.05 MILLIGRAM  
PER CUBIC METER OF AIR

LOCATION \_\_\_\_\_ (1) \_\_\_\_\_ DATE \_\_\_\_\_ (2) \_\_\_\_\_ 19\_\_\_\_

INITIAL READINGS AND SPECIFIC LOCATIONS (SHOW SKETCH ON REVERSE SIDE, IF NECESSARY; INDICATE HEIGHT, FROM FLOOR, READINGS WERE TAKEN)

1. \_\_\_\_\_ (3a) \_\_\_\_\_ mg/m<sup>3</sup> at \_\_\_\_\_ (3b) \_\_\_\_\_
2. \_\_\_\_\_ mg/m<sup>3</sup> at \_\_\_\_\_
3. \_\_\_\_\_ mg/m<sup>3</sup> at \_\_\_\_\_
4. \_\_\_\_\_ mg/m<sup>3</sup> at \_\_\_\_\_
5. \_\_\_\_\_ mg/m<sup>3</sup> at \_\_\_\_\_

AMBIENT TEMPERATURE AT WHICH READINGS TAKEN: \_\_\_\_\_ (4) \_\_\_\_\_ °F.

DESCRIBE ACTION TAKEN, IF ANY: \_\_\_\_\_ (5) \_\_\_\_\_

\_\_\_\_\_  
\_\_\_\_\_  
\_\_\_\_\_  
\_\_\_\_\_  
\_\_\_\_\_  
\_\_\_\_\_

BY: \_\_\_\_\_ (6) \_\_\_\_\_

RETEST DATE: \_\_\_\_\_ (7) \_\_\_\_\_

RETEST READINGS AND SPECIFIC LOCATIONS (8)

1. \_\_\_\_\_ mg/m<sup>3</sup> at \_\_\_\_\_
2. \_\_\_\_\_ mg/m<sup>3</sup> at \_\_\_\_\_
3. \_\_\_\_\_ mg/m<sup>3</sup> at \_\_\_\_\_
4. \_\_\_\_\_ mg/m<sup>3</sup> at \_\_\_\_\_
5. \_\_\_\_\_ mg/m<sup>3</sup> at \_\_\_\_\_

AMBIENT TEMPERATURE \_\_\_\_\_ (9) \_\_\_\_\_ °F. RETEST BY: \_\_\_\_\_ (10) \_\_\_\_\_

\_\_\_\_\_



**Health, Safety and Environmental Standard**

**Distribution Operations**

|                               |                                   |   |
|-------------------------------|-----------------------------------|---|
| Effective Date:<br>04/01/2011 | <b>Welding and Cutting Safety</b> | Standard Number:<br><b>HSE 4120.010</b> |
| Supersedes:<br>NA             |                                   | Page 1 of 9                             |

Companies Affected:

|                                     |   |   |
|-------------------------------------|---|---|
| <input type="checkbox"/> NIPSCO     | <input checked="" type="checkbox"/> CGV | <input checked="" type="checkbox"/> CMD |
| <input type="checkbox"/> NIFL       | <input checked="" type="checkbox"/> CKY | <input checked="" type="checkbox"/> COH |
| <input type="checkbox"/> Kokomo Gas | <input checked="" type="checkbox"/> CMA | <input checked="" type="checkbox"/> CPA |

**REFERENCE** Code of Federal Regulations - Title 29 - (OSHA) Part 1910 - Subparts G, H, I, Q, S, and Z and Part 1926, Subpart J; Code of Federal Regulations - Title 49 - Parts 171-173 and 178. ANSI Z87.1AWS Standard F4.1; ASA Z2.

**1. ARC WELDING EQUIPMENT**

Arc-welding machines shall be maintained in safe working order and not be handled carelessly. Even though the voltages are low and normally will not cause injury or severe shock they are high enough so that under certain circumstances they may be dangerous to life. This is especially true when the welder is wet from perspiration, rain, standing water, etc. Welders should never permit the electrode or the electrode holder to touch either bare skin or any wet covering on the body. Electric shock can be avoided by using electrode holders with well insulated jaws and cables, dry protective coverings on the hands and body, and by not grounding the body.

The hand grip and the outer surfaces of the jaws of the holder shall be fully insulated. Electrode holders shall have a capacity capable of safely handling the maximum rated current required by the electrodes to be used.

Electrodes, when not in use, shall be removed from holders and holders shall be placed so that they cannot make electrical contact with persons, conducting objects, fuel or compressed gas tanks.

Welders shall check their equipment regularly to see that electrical connections and insulation on the holders and cable are in acceptable condition.

Cables shall be of the completely insulated flexible type, capable of handling the maximum current requirements of the work in progress. The following table lists the minimum cable sizes which may be used to carry the current specified.

| <u>Welding Current, Amp.</u> | <u>Cable Size, Number</u> |
|------------------------------|---------------------------|
| 100                          | 4                         |
| 150                          | 3                         |
| 200                          | 2                         |
| 300                          | 1/0                       |

The first ten feet of cable extending back from the electrode holder shall be free from repair or splices. The welder shall not coil or loop welding electrode cable around parts of the

*This document is considered CONTROLLED only when viewed electronically on the Company's intranet. Printed or other electronic copies may not be current, and the intranet version should be used to verify.*



**Distribution Operations**

**Health, Safety and Environmental Standard**

|                               |                                   |   |
|-------------------------------|-----------------------------------|---|
| Effective Date:<br>04/01/2011 | <b>Welding and Cutting Safety</b> | Standard Number:<br><b>HSE 4120.010</b> |
| Supersedes:<br>NA             |                                   | Page 2 of 9                             |

body.

To prevent premature breakdown of the insulation, cables should be kept dry, free from gasoline and oil and protected from external damage. Extreme care should be taken to keep the welding cables away from power supply cables.

Cables with damaged insulation or exposed bare conductors shall be replaced. Joining lengths of work and electrode cables shall be done by the use of connectors specifically intended for the purpose. The connectors shall have insulation adequate for the service conditions.

Engine-driven welding machines are not required to be grounded. Electric motor-driven welding machines must be grounded in accordance with instructions of the manufacturer.

Ground connections shall be checked to determine that they are mechanically strong and electrically adequate for the required current. Precautions shall be used to avoid sparking at the work-lead cable.

Any equipment failure shall be promptly reported in accordance with [GS 1652.010](#) "Investigation of Failures." All equipment that will not operate safely or satisfactorily shall be tagged with Form C-1592, "Do Not Operate," in accordance with [HSE 4100.050\(CG\)](#) or [HSE 4100.050\(VA\)](#) "Tools and Equipment – Plant Operations" and use discontinued until repaired. Repairs shall be made only by qualified personnel.

## **2. GAS WELDING AND CUTTING EQUIPMENT**

### **2.1 General**

Gauges and pressure regulators shall be removed and the valve protection caps installed prior to the transportation of cylinders.

Extreme care should be taken to avoid accumulating and mixing flammable gases and air. To avoid confusion, shielding gases, fuel gases and oxygen should be described by their proper name and not by the words "gas" and "air". No attempts shall be made to mix fuel gases in a cylinder or transfer gas from one cylinder to another.

Only cylinders properly constructed and maintained shall be used. All cylinders shall be legibly marked with the chemical or trade name of the gas. The numbers and markings which are stamped into the cylinder shall not be tampered with. Also, no one shall tamper with the safety devices in the cylinders or valves.

When being stored on the inside of a building, oxygen and fuel-gas cylinders shall be separated by a fire-resisting partition. The storage area shall be a well ventilated, dry location, away from sources of heat, at least 20 feet from highly combustible materials, elevators, stairs or gangways. The cylinders shall be held in position by a chain or other similar devices that will keep them stationery and upright. When stored outside, oxygen and fuel-gas cylinders shall be stored separately. They shall be protected





Distribution Operations

Health, Safety and Environmental Standard

|                               |                                   |   |
|-------------------------------|-----------------------------------|---|
| Effective Date:<br>04/01/2011 | <b>Welding and Cutting Safety</b> | Standard Number:<br><b>HSE 4120.010</b> |
| Supersedes:<br>NA             |                                   | Page 3 of 9                             |

against ice and snow as well as the direct rays of the sun.

Cylinders must be handled very carefully to avoid damaging the cylinder, valve or safety devices. Cylinders shall not be dragged or slid but can be moved for short distances by tilting and rolling on their bottom edge. When being transported by hand truck, they shall be held with a chain or other similar device. When handling cylinders with a crane or derrick, a suitable platform must be used; handling with slings or electric magnets is prohibited. Valve protection caps shall not be used for lifting cylinders from one vertical position to another. However, it is permissible to raise a cylinder from a horizontal to a vertical position by grasping the valve protection cap. Cylinders shall be in an upright position when transported.

Cylinders should be kept far enough away from the actual welding or cutting operations so that sparks, hot slag or flame will not reach them. They shall not be placed where they might become part of an electrical circuit, such as an accidental grounding circuit for electric arc welding. Nothing shall be placed on top of a cylinder when it is in use.

Shielding gases, fuel gas or oxygen shall never be used from cylinders without a pressure regulator attached to the cylinder or manifold.

Before connecting a regulator to a cylinder, the valve shall be cracked (opened slightly) and closed immediately to clear the valve of dust or dirt. Personnel must never stand directly in front of the valve outlet and the valve never opened near a source of ignition. After the regulator is attached, the cylinder valve should be opened slowly to allow the high pressure to bleed gradually into the regulator.

If a leak should develop in a safety device, the cylinder shall be removed to the out-of-doors, well away from any source of ignition. The valve shall then be opened slightly, and the contents allowed to escape. The cylinder shall be tagged and the supplier notified.

The torch and cylinder valves shall be closed when the torch is not in use. Before removing a regulator from a cylinder valve, the valve shall be closed and the gas released from the regulator. Pressure adjusting screws should be backed off completely after regulators are depressurized. Whenever the regulator is removed the protective cap shall be installed.

Empty cylinders shall be marked "empty" or "MT", and separated from the full cylinders for return to the supplier.

**2.2 Fuel-Gas Cylinders**

Acetylene cylinders shall always be in a position of 45° or greater from horizontal when being stored, transported, or used.

Cylinders inside a building, except those in actual use or attached ready for use, shall



**Distribution Operations**

**Health, Safety and Environmental Standard**

|                               |                                   |   |
|-------------------------------|-----------------------------------|---|
| Effective Date:<br>04/01/2011 | <b>Welding and Cutting Safety</b> | Standard Number:<br><b>HSE 4120.010</b> |
| Supersedes:<br>NA             |                                   | Page 4 of 9                             |

be limited to a total gas capacity of 2,000 cubic feet. When the limit is exceeded, the cylinder shall be kept outside and signs posted reading "DANGER - NO SMOKING MATCHES OR OPEN FLAME" or other similar wording.

An acetylene cylinder valve shall not be opened more than 1-1/2 turns of the spindle. If a special wrench is required it shall be left in position on the stem of the valve while the cylinder is in use. In the case of manifolded or coupled cylinders, at least one wrench shall always be available for immediate use. If the valve is opened and a leak is found around the valve stem, the valve should be closed and the gland nut tightened. If this does not stop the leak, the cylinder shall be removed to the out-of-doors, properly tagged, and the supplier advised. A regulator may be attached to a fuel gas cylinder valve to temporarily stop a leak through the valve seat.

**2.3 Oxygen Cylinders**

Oxygen will not burn but it supports and accelerates combustion. Oil or grease in the presence of oxygen under pressure may ignite violently. Therefore, all parts of the oxygen supply system must be kept free from oily or greasy substances. Oxygen cylinders or apparatus shall not be handled with oily gloves nor shall they be placed where they could come in contact with oil or grease. A jet of oxygen should never be allowed to strike an oily surface, greasy clothes, or enter a fuel oil or other storage tank. Oxygen shall never be substituted for compressed air for use in pneumatic tools or similar equipment.

Oxygen cylinders in storage shall be separated from fuel-gas cylinders or combustible materials (especially oil or grease), a minimum distance of 20 feet or by a noncombustible barrier at least 5 feet high having a fire resistance rating of at least one-half hour.

Oxygen cylinder valves shall not be tampered with nor should any attempt be made to repair them. A hammer or wrench should never be used to open cylinder valves. If valves cannot be opened by hand, the supplier should be notified.

After a regulator is attached, the oxygen cylinder valve should be opened slightly. After the pressure is equalized in the gages, the valve should be opened fully in order to prevent leakage around the valve stem. If the high pressure is suddenly released, it is liable to damage the regulator and pressure gages. The person opening the cylinder valve should always stand to one side of the regulator and gages.

**2.4 Manifolding of Cylinders**

Manifolds, when required, shall be installed under the supervision of someone familiar with their construction and use and in accordance with the requirements of CFR - Title 29 - Part 1910.252(a) (c) (3).



**Distribution Operations**

**Health, Safety and Environmental Standard**

|                               |                                   |   |
|-------------------------------|-----------------------------------|---|
| Effective Date:<br>04/01/2011 | <b>Welding and Cutting Safety</b> | Standard Number:<br><b>HSE 4120.010</b> |
| Supersedes:<br>NA             |                                   | Page 5 of 9                             |

**3. FIRE PREVENTION AND PROTECTION**

**3.1 General**

Where practical, move the object to be welded to a safe location designated for welding. If the object cannot readily be moved, all movable fire hazards in the vicinity shall be removed. If neither of these above conditions can be satisfied, the following precautions shall be taken.

- a. Protective shields shall be used to confine the heat, sparks, and slag.
- b. If the floor is constructed of combustible materials, it must be swept clean for a radius of 35 feet, thoroughly wetted with water, or covered with damp sand, sheet metal or other non-flammable material. Provision shall be made to protect welders from shock when floor is wet.
- c. Wherever there are floor openings or cracks in the flooring that cannot be closed, there should be no exposed combustible materials on the floor below. This same precaution should be observed with regard to cracks or holes in walls, open doorways and open or broken windows.
- d. Suitable fire extinguishing equipment shall be available at all times.

**3.2 Prohibited Areas**

Cutting or welding shall not be permitted in the following situations.

- a. In areas not authorized by management.
- b. In sprinkler equipped buildings while such protection is inoperative.
- c. In the presence of explosive atmospheres (mixtures of flammable gases, vapors, liquids, or dusts with air), or explosive atmospheres that may develop inside uncleaned or improperly prepared tanks or equipment which have previously contained such materials, or that may develop in areas with an accumulation of combustible dusts.
- d. In areas near the storage of large quantities of exposed, readily ignitable materials.
- e. In locations where welding or cutting could cause ignition of combustible material unless adequate precautions are taken to prevent or control fires.

**4. WELDING OR CUTTING CLOSED CONTAINERS**

Welding or cutting of drums, barrels, tanks or other containers that have held combustibles should be attempted only by experienced personnel familiar with the requirements of CFR - Title 29 - 1910 252(d)(3) and AWS Standard F 4.1-80.



Distribution Operations

## Health, Safety and Environmental Standard

|                               |                                   |   |
|-------------------------------|-----------------------------------|---|
| Effective Date:<br>04/01/2011 | <b>Welding and Cutting Safety</b> | Standard Number:<br><b>HSE 4120.010</b> |
| Supersedes:<br>NA             |                                   | Page 6 of 9                             |

### 5. PROTECTION OF PERSONNEL

#### 5.1 General

Welders and helpers working on platforms, scaffolds, or runways shall use safety belts, life lines, or similar devices in the absence of railings. Life belts and similar devices should be of a "quick release" type. Welders and helpers working in excavations, tunnels, and below heavy objects shall be protected from falling objects or cave-ins by use of shoring or other appropriate means. Welders shall place welding cable and other equipment so that it is clear of passageways, ladders, and stairways.

#### 5.2 Eye Protection

Contact lenses are not recommended for use by welding personnel for wear during work involving welding, cutting, or grinding operations. Dust, foreign particles, or chemicals may become trapped beneath the lenses.

Helmets shall be used during arc welding or arc cutting operations. Goggles or spectacles with side shields shall also be worn during arc welding or cutting operations to provide protection from injurious rays from adjacent work and from flying objects. The goggles or spectacles may have either clear or colored glass, depending upon the amount of exposure to adjacent welding operations. Helpers or attendants shall be provided with proper eye protection. A face shield shall be worn as a secondary protective device during grinding operations. (See [HSE 4200.030](#) "Eye and Face Protection.")

Goggles or other suitable eye protection shall be used during gas welding or oxygen cutting operations.

Cover lenses or plates shall be provided to protect each helmet, or goggle filter lens or plate.

Glass lenses or plates which have become pitted or scratched should be replaced.

Lenses shall bear some permanent distinctive marking by which the source and shade may be readily identified.

The following is a guide for the selection of the proper shade numbers. These recommendations may be varied to suit the individual's needs.



**Health, Safety and Environmental Standard**

**Distribution Operations**

|                               |                                   |   |
|-------------------------------|-----------------------------------|---|
| Effective Date:<br>04/01/2011 | <b>Welding and Cutting Safety</b> | Standard Number:<br><b>HSE 4120.010</b> |
| Supersedes:<br>NA             |                                   | Page 7 of 9                             |

| <u>Welding Operation</u>                  | <u>Shade Number</u> |
|---|---------------------|
| Shielded metal-arc welding (stick)        | 9-10                |
| Soldering                                 | 2                   |
| Torch brazing                             | 3 or 4              |
| Light cutting, up to 1 inch               | 3 or 4              |
| Gas welding (light) up to 1/8 inch        | 4 or 5              |
| Gas welding (medium) 1/8 inch to 1/2 inch | 5 or 6              |

**5.3 Protection of Other Workers From Arc-Welding Rays**

Where the work permits, the welder should be enclosed in an individual booth painted with a finish of low reflectivity such as zinc oxide (an important factor for absorbing ultraviolet radiations) and lamp black or shall be enclosed with noncombustible screens similarly painted. Booths and screens shall permit circulation of air at floor level. Workers or other persons adjacent to the welding areas shall be protected from the rays by noncombustible or flameproof screens or shields or shall be required to wear appropriate goggles.

**5.4 Protective Clothing and Equipment**

Protective equipment, including personal protective equipment for ears, eyes, face, head, and extremities, protective clothing, respiratory devices, and protective shields and barriers, shall be provided, used, and maintained in a sanitary and reliable condition.

Where employees provide their own protective equipment, the supervisor is responsible to assure its adequacy, including proper maintenance, and sanitation of such equipment.

Welders should wear gauntlet gloves. Flameproof aprons made of leather, or other suitable materials are also desirable. Capes or shoulder covers made of leather or other suitable material should be worn during overhead welding or cutting operations. Outer clothing should be reasonably free from oil or grease. It is recommended that sleeves and collars be kept buttoned and pockets be eliminated from the front of overalls and apron. Trousers or overalls should not be turned up on the outside. Low-cut shoes with unprotected tops should not be used. Caps shall be worn under helmets to prevent head burns.

For overhead welding, or welding in tight spaces, ear protection is required. This may be accomplished by placing plugs in the ears or by covering the ears with suitable protection.

**5.5 Work in Tight Spaces**

Refer to NGD Health & Safety Procedure "Safe Entry into Gas Vaults and Pits" and [HSE 4100.010](#) "Hazardous Atmosphere Considerations."



Distribution Operations

Health, Safety and Environmental Standard

|                               |                                   |   |
|-------------------------------|-----------------------------------|---|
| Effective Date:<br>04/01/2011 | <b>Welding and Cutting Safety</b> | Standard Number:<br><b>HSE 4120.010</b> |
| Supersedes:<br>NA             |                                   | Page 8 of 9                             |

**5.6 Ventilation and Health Protection**

Sufficient ventilation for respiratory protection shall always be provided. When welding in a space screened on all sides, a space of at least two feet between the bottom of the screen and floor shall be provided so as not to restrict air movement.

Mechanical ventilation shall be provided when welding or cutting:

- a. In a space of less than 10,000 cubic feet per welder.
- b. In a room having a ceiling height of less than 16 feet.
- c. In tight spaces or where the welding space contains partitions, balconies, or other structural barriers to the extent that they significantly obstruct cross ventilation.

Such ventilation shall be at the minimum rate of 2,000 cubic feet per minute per welder, except where local exhaust hoods and booths or airline respirators approved by the U.S. Bureau of Mines for such purposes are provided.

Mechanical local exhaust ventilation may be by means of either of the following.

- a. Hoods. Freely movable hoods intended to be placed by the welder as near as practicable to the work being welded and provided with a rate of airflow sufficient to maintain a velocity in the direction of the hood of 100 linear feet per minute in the zone of welding when the hood is at its most remote distance from the point of welding. The rates of ventilation required to accomplish this control velocity using a 3-inch wide flanged suction opening are shown in the following table.

| <u>Welding Zone</u>               | <u>Minimum Air Flow*</u><br><u>Cubic feet/minute</u> | <u>Duct Diameter</u><br><u>Inches**</u> |
|-----------------------------------|--|---|
| 4 to 6 inches from arc or torch   | 1500   | 3                                       |
| 6 to 8 inches from arc or torch   | 275  | 3 1/2                                   |
| 8 to 10 inches from arc or torch  | 425  | 4 1/2                                   |
| 10 to 12 inches from arc or torch | 600  | 5 1/2                                   |

\*Brazing with cadmium bearing materials is prohibited.

\*\*Nearest half-inch duct diameter based on 4,000 feet per minute velocity in pipe.



## Health, Safety and Environmental Standard

### Distribution Operations

|                               |                                   |   |
|-------------------------------|-----------------------------------|---|
| Effective Date:<br>04/01/2011 | <b>Welding and Cutting Safety</b> | Standard Number:<br><b>HSE 4120.010</b> |
| Supersedes:<br>NA             |                                   | Page 9 of 9                             |

- b. Fixed Enclosure. A fixed enclosure with a top and not less than two sides which surround the welding or cutting operations and with a rate of airflow sufficient to maintain a velocity away from the welder of not less than 100 linear feet per minute.

Ventilating systems shall keep the amount of toxic fumes or dust below the maximum allowable concentration as specified in OSHA Subpart Z. When ventilating is impractical, welders must use respiratory protective equipment approved by the U.S. Bureau of Mines. In tight spaces or other locations where the amount of toxic substances may exceed the maximum allowable concentrations, supplied-air respirators are required. This applies not only to the welder but also the helpers and other personnel in the immediate vicinity. Air supply for such equipment shall be clean and of suitable temperature. When welding is one small operation in a large area, it is best to apply local exhaust ventilation to prevent contamination of the general work area.



**Distribution Operations**

**Gas Standard**

|                               |                                       |   |
|-------------------------------|---------------------------------------|---|
| Effective Date:<br>05/01/2012 | <b>Respiratory Protection Program</b> | Standard Number:<br><b>HSE 4200.010</b> |
| Supersedes:<br>04/01/2009     |                                       | Page 1 of 17                            |

Companies Affected:

|                                 |   |   |
|---------------------------------|---|---|
| <input type="checkbox"/> NIPSCO | <input checked="" type="checkbox"/> CGV | <input checked="" type="checkbox"/> CMD |
|                                 | <input checked="" type="checkbox"/> CKY | <input checked="" type="checkbox"/> COH |
|                                 | <input checked="" type="checkbox"/> CMA | <input checked="" type="checkbox"/> CPA |

**1. PURPOSE**

This procedure protects all NiSource employees from respiratory hazards through the proper use of respirators.

**2. SCOPE**

This program applies to all employees who are required to wear respiratory protection to prevent exposure to airborne contaminants and/or oxygen deficient atmospheres. It also applies to employees who voluntarily wear respirators in areas where inhalation hazards do not require respirators be used.

Additional requirements for respiratory protection are stated in HSE 4100.010 *Hazardous Atmosphere Considerations*.

**3. RESPONSIBILITIES**

**3.1 Employees**

Employees who wear respiratory protection are responsible for the following.

- a. Knowing the respiratory hazards and requirements at their work areas or job assignments and following any worksite-specific procedures.
- b. Using approved respiratory protective equipment that the employee wore when they passed their most recent fit tests.
- c. Properly maintaining and cleaning their respiratory protection equipment.
- d. Performing all user seal checks prior to use.
- e. Successfully completing all respiratory program training.
- f. Reporting any personal changes which may affect their using a respirator.
- g. Reporting any equipment malfunctions or concerns.

*This document is considered CONTROLLED only when viewed electronically on the Company's intranet. Printed or other electronic copies may not be current, and the intranet version should be used to verify.*





**Distribution Operations**

**Gas Standard**

|                               |                                       |   |
|-------------------------------|---------------------------------------|---|
| Effective Date:<br>04/01/2012 | <b>Respiratory Protection Program</b> | Standard Number:<br><b>HSE 4200.010</b> |
| Supersedes:<br>04/01/2009     |                                       | Page 2 of 17                            |

**3.2 Local Management**

Local management shall determine what employees are required to wear a respirator and shall be responsible for the following.

- a. Ensuring that employees under their direction are fully knowledgeable of the respiratory protection requirements for the areas and jobs where they are assigned to work which require respiratory protection.
- b. Notifying the site Respiratory Program Administrator of any problems with respirator use or any changes in work processes that would impact respiratory hazards.
- c. Ensuring that employees receive necessary training and medical evaluations.
- d. Ensuring that employees comply with all the program's requirements.

**3.3 HSE Coordinator**

The local HSE Coordinator shall be the site-specific Respiratory Program Administrator and shall be responsible for the following.

- a. Maintain a current list of approved respirator wearers, including training, medical clearance, fit tests, and the types of respirators which have been approved for use.
- b. Ensure that an adequate supply of approved respirators and replacement cartridges are available.
- c. Coordinate medical evaluations and fit testing.
- d. Audit the program for continued effectiveness.
- e. Request that monitoring be conducted as necessary.
- f. Coordinate annual re-training.

**4. PROCEDURE**

**4.1 Program Elements**

**4.1.1 Workplace Evaluations/Hazard Assessments**

Each workplace must be evaluated for possible oxygen deficiency and airborne contaminants. A Job Hazard Assessment may be conducted in workplaces with the possibility of respiratory hazards.

Once a respiratory hazard has been identified, the work area must be monitored, as necessary, for any changes in concentration levels or for new hazards. Changes in work processes, substitution of materials, or changes in



Distribution Operations

Gas Standard

|                               |                                       |   |
|-------------------------------|---------------------------------------|---|
| Effective Date:<br>04/01/2012 | <b>Respiratory Protection Program</b> | Standard Number:<br><b>HSE 4200.010</b> |
| Supersedes:<br>04/01/2009     |                                       | Page 3 of 17                            |

the ventilation of an area may necessitate re-testing.

#### 4.1.2 Respirator Selection Method

Engineering and administrative controls will first be considered as a means to reduce the hazards. Engineering controls can include enclosure, substitution, process modification, and ventilation. Administrative controls include scheduling changes to reduce time spent in contaminated areas.

In situations where engineering and/or administrative controls do not sufficiently reduce exposures below Permissible Exposure Levels (PEL) or where oxygen deficient or **IDLH** atmospheres are present, respirators are required.

Only **NIOSH** approved respirators shall be used. Respirator types, models, sizes, and cartridges are not interchangeable.

The site Respiratory Program Administrator will use the NIOSH respirator decision tree as a guideline (see Exhibit A) to determine proper respiratory selection and use.

An employee shall wear only a respirator that has been fit tested and approved for the employee and the hazards of the exposure.

If the employee exposure cannot be identified or estimated, then the atmosphere must be considered IDLH.

Air purifying respirators shall not be used in oxygen deficient atmospheres, IDLH atmospheres, or unknown atmospheres. All confined spaces shall be considered IDLH unless proven otherwise.

#### 4.2 VOLUNTARY USE OF RESPIRATORS

Employees will be allowed to use respirators voluntarily if the respirator itself will not create a hazard.

Employees whose only use of a respirator is the voluntary use of a dust mask (filtering face piece) are not subject to the requirements of the written program.

Employees voluntarily wearing respirators other than dust masks are subject to the requirements of this program, including medical evaluations, fit testing, training and the maintenance procedures.

All employees voluntarily wearing respirators will sign a copy of 29 CFR 1910.134 Appendix D "Mandatory Information for Employees Using Respirators When Not Required Under the Standard." See Exhibit B.



|                               |                                       |   |
|-------------------------------|---------------------------------------|---|
| Effective Date:<br>04/01/2012 | <b>Respiratory Protection Program</b> | Standard Number:<br><b>HSE 4200.010</b> |
| Supersedes:<br>04/01/2009     |                                       | Page 4 of 17                            |

### **4.3 Maintenance of Respiratory Equipment**

#### **4.3.1 Cleaning**

Each employee shall be provided with a respirator that is clean, sanitary and in good working order.

The frequency for cleaning and disinfecting is as follows.

- a. Respirators used by only one employee shall be cleaned and disinfected as often as necessary to be maintained in a sanitary condition.
- b. Emergency use respirators must be cleaned and disinfected after each use.

#### **4.3.2 Storage**

Respirators shall be stored so as to protect them from damage, contamination, dust, sunlight, extreme temperatures, excessive moisture and damaging chemicals.

Respirators shall be stored in such a manner as to prevent deformation of the face piece and valves.

#### **4.3.3 Inspection**

Respirators used in routine situations shall be inspected before each use and during cleaning.

A respirator inspection includes the following activities.

- a. A check of respirator function, tightness of connections, and the condition of the various parts, including the face piece, head straps, valves, connecting tubes, cartridges, canisters and filters.
- b. A check of the elastic parts for pliability or deterioration.
- c. Emergency use respirators shall be inspected in accordance with the manufacturer's instructions including checking for proper function before and after each use.



**Distribution Operations**

**Gas Standard**

|                               |                                       |   |
|-------------------------------|---------------------------------------|---|
| Effective Date:<br>04/01/2012 | <b>Respiratory Protection Program</b> | Standard Number:<br><b>HSE 4200.010</b> |
| Supersedes:<br>04/01/2009     |                                       | Page 5 of 17                            |

- d. SCBA Air Cylinders shall be inspected by filling the cylinder with Type 1 – Grade D breathing air and hydrostatically tested per manufacturer’s requirements. Air supplied for SCBA cylinders shall have a certificate of analysis from the supplier stating that the air meets Grade D breathing air.

The following Table provides the frequency of inspection.

| <b>Respirator Type</b> | <b>Frequency of Inspection</b>      |
|------------------------|-------------------------------------|
| Emergency Use          | Monthly                             |
| Escape-only            | Before being brought into work area |
| SCBA Air Cylinders     | Monthly                             |

**4.3.4 Repairs**

Respirators that fail inspections or are otherwise found to be defective shall be removed from service and discarded, repaired, or adjusted by appropriately trained persons, with NIOSH approved parts, according to manufacturer’s specifications.

Valves, regulators and alarms shall be adjusted or repaired only by the manufacturer or manufacturer’s representative.

**4.3.5 Labeling**

Filters, cartridges and canisters must be labeled and color coded with the NIOSH approval label. The label is not to be removed and must remain legible and shall be stored in a sealable bag when not in use.

**4.4 Respirator Types**

Respirator types, models, and sizes are not interchangeable. An employee shall only wear a respirator which has been fit tested and approved for the employee’s use.

When required, emergency use respirators shall be kept accessible to the work area, in compartments or covers that are clearly marked as containing emergency respirators, and stored in accordance with the manufacturer’s instructions.

Cartridges and filters are specific to certain hazards. Use the cartridge approved for the task. Do not interchange manufacturer’s cartridges or filters.

There are limits to the concentration levels that can be used with half mask and full



**Distribution Operations**

**Gas Standard**

|                               |                                       |   |
|-------------------------------|---------------------------------------|---|
| Effective Date:<br>04/01/2012 | <b>Respiratory Protection Program</b> | Standard Number:<br><b>HSE 4200.010</b> |
| Supersedes:<br>04/01/2009     |                                       | Page 6 of 17                            |

face respirators. Consult the Respirator Program Administrator to determine if you have the proper level of protection.

**4.5 Limitations**

Anything that breaks the seal of a respirator will reduce its effectiveness. Employees who are respirator qualified must remain clean shaven at all times except as shown in Exhibit D. Facial hair that lies along the sealing area of a respirator, such as beards, sideburns, moustaches, or even a few days growth of stubble, is not permitted on employees who are required to wear respirators that rely on a tight face piece fit to achieve maximum protection.

Temple bars of glasses and head coverings are not to be worn when they interfere with respirator fit. Corrective lenses can be fitted inside a full-face respirator with a special insert kit.

**4.6 MEDICAL EVALUATIONS**

Prior to fit testing or initial use of a respirator, every employee must be medically evaluated.

**4.6.1 Evaluation**

Medical evaluations shall be conducted by a designated physician or other licensed health care professional (PLHCP). Medical evaluations shall consist of either a medical questionnaire or an initial medical examination that obtains the same information as the questionnaire.

Responses to the questionnaire are mandatory.

Medical questionnaires and examinations shall be administered confidentially.

Based on questionnaire responses, follow-up medical evaluations may be required. The follow-up medical evaluation may include any medical tests, consultations or diagnostic procedures that the PLHCP deems necessary to make a final determination of the employee's ability to wear a respirator.

The following information shall be supplied to the PLHCP before a recommendation is made.

- a. Type and weight of the respirator to be used.
- b. Duration and frequency of use.
- c. Expected physical effort.



|                               |                                       |   |
|-------------------------------|---------------------------------------|---|
| Effective Date:<br>04/01/2012 | <b>Respiratory Protection Program</b> | Standard Number:<br><b>HSE 4200.010</b> |
| Supersedes:<br>04/01/2009     |                                       | Page 7 of 17                            |

- d. Additional protective clothing and equipment to be worn.
- e. Temperature and humidity that may be encountered.
- f. A copy of the written program and the regulation.

**4.6.2 Written Recommendation**

The Program Administrator shall obtain a written recommendation from the PLHCP on whether or not the employee is medically able to use the respirator. The recommendation shall include only the following information.

- a. Any limitations on respirator use related to the medical condition of the employee or workplace conditions including whether the employee is medically able to wear the respirator.
- b. The need, if any, for a follow up medical examination.
- c. A statement that the PLHCP has provided the employee with a copy of the recommendation.

The employee shall receive a copy of the PLHCP's recommendation.

The employee shall have an opportunity to discuss the questionnaire and examination with the PLHCP.

If the PLHCP finds an employee cannot use a negative pressure respirator, a PAPR will be provided, if suitable.

**4.6.3 Additional Medical Evaluations**

Additional medical evaluations shall be provided if:

- a. an employee reports medical signs or symptoms related to the ability to use a respirator,
- b. a PLHCP, supervisor, or the program administrator deems an employee needs re-evaluation,
- c. information from the program, observations during fit tests, or evaluations indicate the need for re-evaluation, or
- d. changes in the workplace conditions result in increased physiological burden on the employee.

|                               |                                       |   |
|-------------------------------|---------------------------------------|---|
| Effective Date:<br>04/01/2012 | <b>Respiratory Protection Program</b> | Standard Number:<br><b>HSE 4200.010</b> |
| Supersedes:<br>04/01/2009     |                                       | Page 8 of 17                            |

#### **4.7 FIT TESTING**

Before wearing a respirator, employees are required to be fit tested with the same make, model, style and size of respirator that will be used.

Employees shall wear only respirators which they have been fit tested on and approved for use.

Fit tests shall follow the procedures outlined in 29 CFR 1910.134. Contact the Respiratory Program Administrator for additional information.

Qualified personnel shall perform the fit test.

Fit testing shall be conducted initially, annually, and whenever changes in an employee's physical condition could affect respirator fit.

Records shall be maintained by the Respiratory Program Administrator and shall include names, dates, types of tests, results and make, model, style and size of the respirator fitted.

Tight fitting face pieces are not to be worn by employees:

- a. who have facial hair that comes between the sealing surface and the face, or that interferes with valve function, or
- b. who have any condition that interferes with the seal, such as missing dentures, jewelry, or headgear if corrective glasses, goggles or other PPE.

##### **4.7.1 Seal Check**

Employees must perform a user seal check each time they put on the respirator according to the procedures in Exhibit C.

Employees must be allowed to leave the respirator use area:

- a. to wash their faces and respirators as necessary to prevent eye or skin irritation, or
- b. if they detect vapor or gas breakthrough, changes in breathing resistance, or leakage of the face piece, or
- c. to replace the respirator or the filter cartridges or canisters.

A defective respirator must be replaced or repaired before being used in any work activity.

#### **5. TRAINING**

All employees who are required to wear respirators will receive initial training in their use



|                               |                                       |   |
|-------------------------------|---------------------------------------|---|
| Effective Date:<br>04/01/2012 | <b>Respiratory Protection Program</b> | Standard Number:<br><b>HSE 4200.010</b> |
| Supersedes:<br>04/01/2009     |                                       | Page 9 of 17                            |

and maintenance. Employees must be trained sufficiently to demonstrate the following.

- a. Knowledge of why the respirator is required.
- b. How improper fit, usage or maintenance can compromise the protectiveness of the respirator.
- c. The limitations and capabilities of the respirator.
- d. How to deal with emergencies or malfunctions.
- e. How to inspect, don and remove, and check the seal of the respirator.
- f. Maintenance and storage procedures.
- g. Medical symptoms and signs that may limit or prevent the effective use of respirators.

#### **5.1.1 Frequency**

Training will be provided annually and whenever any one of the following occurs.

- a. Changes in the workplace or type of respirator used.
- b. Inadequacies in the employee's knowledge or use of the respirator are apparent.
- c. Any other situation in which re-training is necessary to ensure safe respirator use.

#### **5.1.2 LMS**

All training records shall be entered into the NiSource Learning Management System (LMS).

### **6. RECORDS**

A written copy of this Program shall be maintained by the Respiratory Program Administrator and is available to all employees for review.

A copy of the employee's most current fit test shall be maintained by the Respiratory Program Administrator.

Records of medical evaluations shall be kept for the duration of the wearer's employment and 30 years following per NiSource record retention guidelines.

### **7. DEFINITIONS**

**Administrative Controls** - Administrative changes in work schedules or procedures that reduce employee exposure to respiratory hazards.





**Distribution Operations**

**Gas Standard**

|                               |                                       |   |
|-------------------------------|---------------------------------------|---|
| Effective Date:<br>04/01/2012 | <b>Respiratory Protection Program</b> | Standard Number:<br><b>HSE 4200.010</b> |
| Supersedes:<br>04/01/2009     |                                       | Page 10 of 17                           |

**Air purifying respirator (APR)** - A respirator with an air purifying filter cartridge or canister that removes specific air contaminants by passing ambient air through the air purifying element.

**Atmosphere Supplying Respirator** - A respirator that supplies the wearer with breathing air from a source independent of the ambient air, including supplied air respirators (SAR) and self-contained breathing apparatus (SCBA).

**Canister Or Cartridge** - Means a container with a filter, sorbent or catalyst, or a combination of these items, which removes specific contaminants from the air passed through the container.

**Contaminants** - Substances in the air that can cause immediate (acute) or long term (chronic) health problems.

**Concentration** - The amount of contaminant in the air, measured in parts per million (ppm) or milligrams per cubic meter (mg/m<sup>3</sup>).

**Demand Respirator** - Means an atmosphere supplying respirator that admits breathing air to the face piece only when a negative pressure is created inside the face piece by inhalation.

**Dusts** - Are fine particles that are created when solid material breaks down. Operations that typically create dust are grinding, crushing, drilling, sanding and milling.

**Emergency Situation** - Means any occurrence such as, but not limited to, equipment failure, rupture of containers, or failure of control equipment that may or does result in an uncontrolled significant release of an airborne contaminant.

**Employee Exposure** - Means an exposure to a concentration of an airborne contaminant that would occur if the employee were not using respiratory protection.

**End of Service Life Indicator (ESLI)** - A system that warns the respirator user of the approach of the end of adequate respiratory protection, for example, that the sorbent is approaching saturation or is no longer effective.

**Engineering Controls** - Specialized equipment, processes or practices that can reduce employee exposure to respiratory hazards.

**Escape Only Respirator** - A respirator that is intended to be used only for emergency exit.

**Exposure** - coming into contact with a hazardous substance through inhalation, ingestion, skin contact or absorption.

**Fit Factor** - Means a quantitative estimate of the fit of a particular respirator to a specific individual, and typically estimates the ratio of the concentration of a substance in ambient air to its concentration inside the respirator when worn.



**Distribution Operations**

**Gas Standard**

|                               |                                       |   |
|-------------------------------|---------------------------------------|---|
| Effective Date:<br>04/01/2012 | <b>Respiratory Protection Program</b> | Standard Number:<br><b>HSE 4200.010</b> |
| Supersedes:<br>04/01/2009     |                                       | Page 11 of 17                           |

**Fit Test** - Means the use of a protocol to qualitatively or quantitatively evaluate the fit of a respirator on an individual.

**Fumes** - Are created when solid materials vaporize under extreme heat. As the vapor cools it condenses into an extremely small particle, e.g., fumes are created during welding and cutting of steel.

**Gases** - Like air have the ability to diffuse and spread throughout an enclosure or area. Examples of gases are nitrogen, carbon monoxide and carbon dioxide.

**IDLH** - Immediately Dangerous to Life or Health.

**Mists** - Are created when liquids are atomized and condensed. Typical sources of mists are spraying operations, mixing and cleaning operations.

**MSDS** - Material Safety Data Sheet.

**Negative Pressure Respirator** - A tight fitting respirator in which the air pressure inside the face piece is negative during inhalation with respect to the ambient air outside the respirator.

**National Institute of Occupational Safety & Health (NIOSH)** - A federal agency which establishes minimum performance standards for respirators and approves respirators for various uses.

**Oxygen Deficiency** - Too little oxygen in the air, which can result in illness or injury to employees. By OSHA definition, it is an oxygen level less than 19.5%.

**Powered air purifying respirator (PAPR)** - A respirator that uses a blower to force the ambient air through air purifying elements to the inlet covering.

**Permissible Exposure Level (PEL)** - Established by OSHA PELs are the maximum allowable concentrations of substances in the air that an employee can be exposed to without harmful effects during an 8-hour period.

**Physician or other licensed health care professional (PLHCP)** - A person whose legally permitted scope of practice allows him or her to independently provide or be delegated the responsibility to provide some or all of the health care services required by this program.

**Positive Pressure Respirator** - Means a respirator in which the pressure inside the respiratory inlet covering exceeds the ambient air pressure outside the respirator.

**Quantitative Fit Test (QNFT)** - Means an assessment of the adequacy of respirator fit by numerically measuring the amount of leakage into the respirator.

**Respiratory Inlet Covering** - Means that portion of a respirator that forms the protective barrier between the user's respiratory tract and an air purifying device or breathing air source, or both. It may be a face piece, helmet, hood, suit or a mouthpiece respirator with



**Distribution Operations**

**Gas Standard**

|                               |                                       |   |
|-------------------------------|---------------------------------------|---|
| Effective Date:<br>04/01/2012 | <b>Respiratory Protection Program</b> | Standard Number:<br><b>HSE 4200.010</b> |
| Supersedes:<br>04/01/2009     |                                       | Page 12 of 17                           |

nose-clamp.

**Self Contained Breathing Apparatus (SCBA)** - Means an atmosphere supplying respirator for which the breathing air source is designed to be carried by the user.

**Supplied Air Respirator (SAR)** - Means an atmosphere supplying respirator for which the source of breathing air is not designed to be carried by the user. (e.g., an airline respirator).

**Tight Fitting Face piece** - A respirator with an inlet covering that forms a complete seal with the face.

**Threshold Limit Value (TLV)** - Exposure guidelines established by ACIGH which have been established for airborne concentrations of many chemical compounds.

**Time Weighted Average (TWA)** - A weighted average exposure level over a given amount of time, usually 8 hours.

**User seal check** - Means an action conducted by the respirator user to determine if the respirator is properly sealed to the face.

**Vapors** - Are formed through the evaporation of liquids or solids. Examples include gasoline, paint thinners, and solvents.

## 8. REFERENCES

29 CFR 1910.134



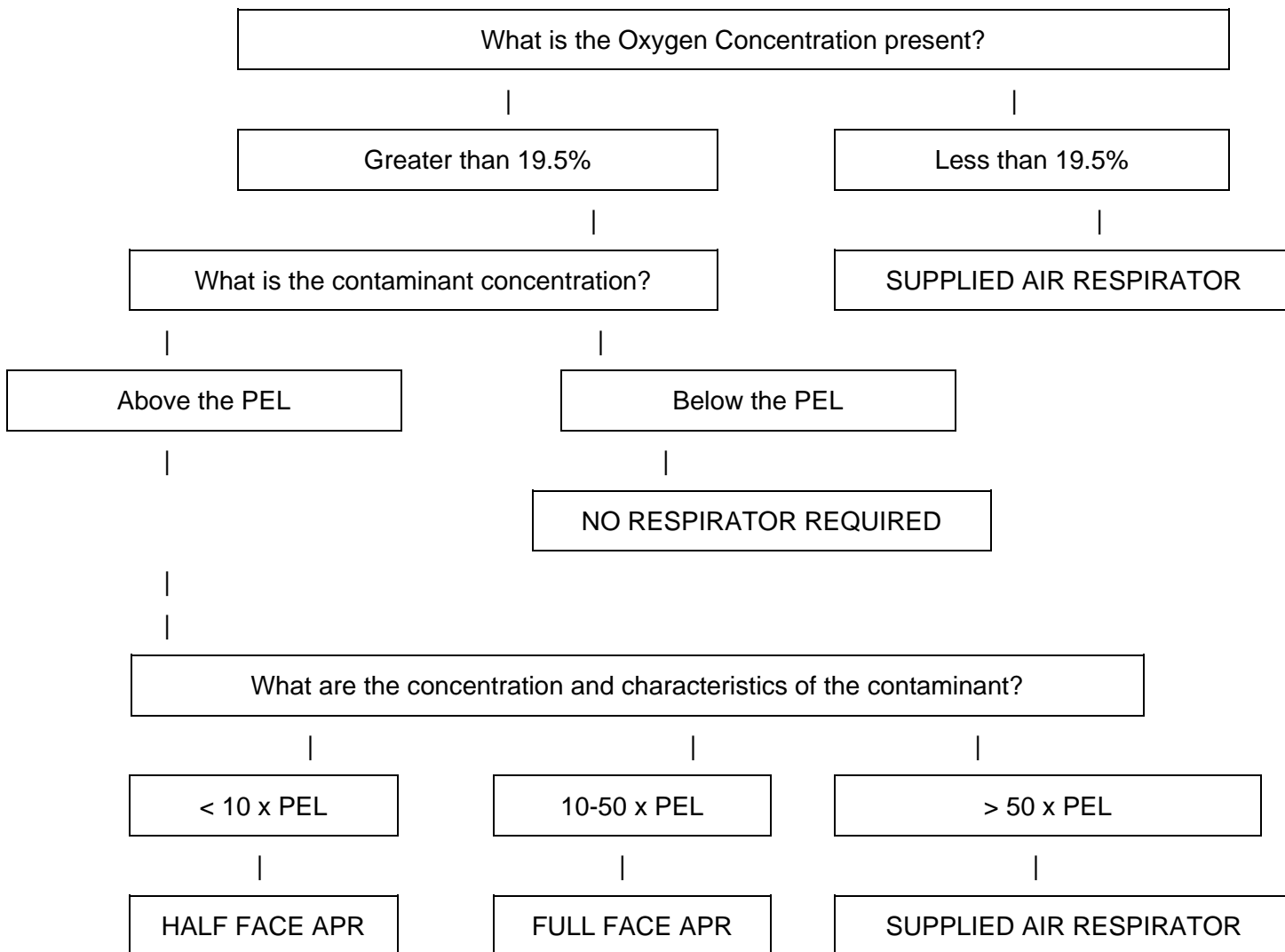
Distribution Operations

Gas Standard

|                               |                                       |   |
|-------------------------------|---------------------------------------|---|
| Effective Date:<br>04/01/2012 | <b>Respiratory Protection Program</b> | Standard Number:<br><b>HSE 4200.010</b> |
| Supersedes:<br>04/01/2009     |                                       | Page 13 of 17                           |

**EXHIBIT A**

**NIOSH DECISION TREE – RESPIRATOR SELECTION**





Distribution Operations

Gas Standard

|                               |                                       |   |
|-------------------------------|---------------------------------------|---|
| Effective Date:<br>04/01/2012 | <b>Respiratory Protection Program</b> | Standard Number:<br><b>HSE 4200.010</b> |
| Supersedes:<br>04/01/2009     |                                       | Page 14 of 17                           |

**EXHIBIT B**

**VOLUNTARY RESPIRATORY USE FORM**

**Mandatory Information for Employees Using Respirators When Not Required Under the Standard**

**(29 CFR 1910.134 Appendix D)**

Respirators are an effective method of protection against designated hazards when properly selected and worn. Respirator use is encouraged, even when exposures are below the exposure limit, to provide an additional level of comfort and protection for workers. However, if a respirator is used improperly or not kept clean, the respirator itself can become a hazard to the worker. Sometimes, workers may wear respirators to avoid exposures to hazards, even if the amount of hazardous substance does not exceed the limits set by OSHA standards. If your employer provides respirators for your voluntary use, or if you provide your own respirator, you need to take certain precautions to be sure that the respirator itself does not present a hazard.

You should do the following:

1. Read and heed all instructions provided by the manufacturer on use, maintenance, cleaning and care, and warnings regarding the respirators limitations.
2. Choose respirators certified for use to protect against the contaminant of concern. NIOSH, the National Institute for Occupational Safety and Health of the U.S. Department of Health and Human Services, certifies respirators. A label or statement of certification should appear on the respirator or respirator packaging. It will tell you what the respirator is designed for and how much it will protect you.
3. Do not wear your respirator into atmospheres containing contaminants for which your respirator is not designed to protect against. For example, a respirator designed to filter dust particles will not protect you against gases, vapors, or very small solid particles of fumes or smoke.
4. Keep track of your respirator so that you do not mistakenly use someone else's respirator.

I have read and understand the above information.

Employee Name (printed): \_\_\_\_\_

Employee Name (signature): \_\_\_\_\_

Date: \_\_\_\_\_



**Distribution Operations**

**Gas Standard**

|                               |                                       |   |
|-------------------------------|---------------------------------------|---|
| Effective Date:<br>04/01/2012 | <b>Respiratory Protection Program</b> | Standard Number:<br><b>HSE 4200.010</b> |
| Supersedes:<br>04/01/2009     |                                       | Page 15 of 17                           |

**EXHIBIT C  
(1 of 2)**

**USER SEAL CHECK PROCEDURES**

An employee using a tight-fitting respirator shall perform a user seal check to ensure that an adequate seal is achieved each time the respirator is put on. Either the positive and negative pressure checks shall be used.

**Face Piece Positive and/or Negative Pressure Checks**

- A. Positive pressure check. Close off the exhalation valve and exhale gently into the face piece. The face fit is considered satisfactory if a slight positive pressure can be built up inside the face piece without any evidence of outward leakage of air at the seal. For most respirators this method of leak testing requires the wearer to first remove the exhalation valve cover before closing off the exhalation valve and then carefully replacing it after the test.
  
- B. Negative pressure check. Close off the inlet opening of the canister or cartridge(s) by covering with the palm of the hand(s) or by replacing the filter seal(s), inhale gently so that the face piece collapses slightly, and hold the breath for ten seconds. The design of the inlet opening of some cartridges cannot be effectively covered with the palm of the hand. The test can be performed by covering the inlet opening of the cartridge with a thin latex or nitrile glove. If the face piece remains in its slightly collapsed condition and no inward leakage of air is detected, the tightness of the respirator is considered satisfactory.



**Distribution Operations**

**Gas Standard**

|                               |                                       |   |
|-------------------------------|---------------------------------------|---|
| Effective Date:<br>04/01/2012 | <b>Respiratory Protection Program</b> | Standard Number:<br><b>HSE 4200.010</b> |
| Supersedes:<br>04/01/2009     |                                       | Page 16 of 17                           |

**EXHIBIT C  
(2 of 2)**

**SERVICE LIFE – CANISTER/CARTRIDGE**

If the employee experiences breakthrough on the job after a proper seal check has been performed or the end of service life indicator shows that the canister needs replacing, or the canister has been used for one full shift (8 hrs.), the canister must be replaced immediately. The employee must leave the contaminated area to replace the canister and perform a new seal check before re-entering the work area.

Service Life is the length of time a canister/cartridge will effectively remove contaminants.

Factors which shorten a Canister's/Cartridge's Service Life include the following.

- a. Use in very dry or very humid environment. Note: While the service life may drop dramatically with increased humidity, other cartridges (i.e., acid gas) may work better in humid environments.
- b. Breathing rate of wearer. If the wearer has a rapid breathing rate such as might occur during heavy work, saturation will occur in less time.
- c. Concentration of the contaminant. The higher the concentration of the chemical, the faster it will saturate the canister/cartridge.
- d. Type of adsorbent used. Sorbent characteristics will depend upon the type, mesh size, quantity, and other characteristics of the materials used, and will differ from manufacturer to manufacturer.
- e. Improper storage or length of storage. Humidity during storage may alter sorbent characteristic and/or an old canister/cartridge may have lost some of its activity.

Note: Any filter/cartridge combination used in Asbestos abatement shall be waste tracked and shall not be disposed of in general/non-hazardous waste containers.

|                               |                                       |   |
|-------------------------------|---------------------------------------|---|
| Effective Date:<br>04/01/2012 | <b>Respiratory Protection Program</b> | Standard Number:<br><b>HSE 4200.010</b> |
| Supersedes:<br>04/01/2009     |                                       | Page 17 of 17                           |

EXHIBIT D

UNACCEPTABLE



Full Beard



Goatee & Narrow Mustache



Goatee & Wide Mustache



Extended Sideburns



Fu Manchu Mustache



Wide Mustache

ACCEPTABLE



Sideburns



Narrow Mustache





**Distribution Operations**

**Health, Safety and Environmental Standard**

|                               |                            |   |
|-------------------------------|----------------------------|---|
| Effective Date:<br>06/01/2016 | <b>Protective Footwear</b> | Standard Number:<br><b>HSE 4200.020</b> |
| Supersedes:<br>04/05/2010     |                            | Page 1 of 4                             |

Companies Affected:

|                                 |   |   |
|---------------------------------|---|---|
| <input type="checkbox"/> NIPSCO | <input checked="" type="checkbox"/> CGV | <input checked="" type="checkbox"/> CMD |
|                                 | <input checked="" type="checkbox"/> CKY | <input checked="" type="checkbox"/> COH |
|                                 | <input checked="" type="checkbox"/> CMA | <input checked="" type="checkbox"/> CPA |

**REFERENCE** OSHA 29 CFR 1910.132, OSHA 29 CFR 1910.136, ANSI Z41 – 1999, ASTM F2412-05 and ASTM F2413-05

**1. PURPOSE**

To ensure the safety of employees, appropriate safety footwear must be worn by all personnel in areas where there is a danger of foot hazards due to falling or rolling objects, objects piercing the sole, uneven terrain, slippery walking surfaces, and when climbing and descending.

**2. SCOPE**

This document applies to all employees when engaged in work activities where exposures to foot hazards are encountered.

This standard shall adhere to local operating Company contracts.

**3. RESPONSIBILITIES**

**3.1 Employees**

All NiSource Distribution Operations employees exposed to foot hazards shall be required to wear an approved sturdy work boot (protective footwear) at all times.

The protective footwear is the responsibility of the employee. Protective footwear that is lost, stolen, or damaged, shall be replaced immediately.

**3.2 Local Management**

It is the responsibility of local management to enforce the use of appropriate safety footwear for all employees whose work exposes them to foot hazards.

**3.3 HSE Department**

The Health Safety and Environmental (HSE) department is responsible for ongoing hazard assessments, designation of appropriate footwear, and is available to assist with the selection of protective footwear.

*This document is considered CONTROLLED only when viewed electronically on the Company's intranet. Printed or other electronic copies may not be current, and the intranet version should be used to verify.*



Distribution Operations

## Health, Safety and Environmental Standard

|                               |                            |   |
|-------------------------------|----------------------------|---|
| Effective Date:<br>06/01/2016 | <b>Protective Footwear</b> | Standard Number:<br><b>HSE 4200.020</b> |
| Supersedes:<br>04/05/2010     |                            | Page 2 of 4                             |

### 4. SPECIFICATION

#### 4.1 Safety Features

All protective footwear shall have the following features:

- a. pronounced heel,
- b. over the ankle,
- c. full tie or pull on (e.g., Wellington style), and
- d. slip resistant sole.

Table 1 provides additional requirements for hard toe protection and 100% upper leather footwear.

#### 4.2 Hard Toe

Hard toe protective footwear shall comply with OSHA 1910.136 guidelines, ASTM F2412-11 and F2413-11 standards. Hard toe protective footwear purchased shall have a Class 75 Impact and Compression protection.

Note: Hard toe protective footwear meeting these requirements will be clearly and legibly identified with letters and numbers (e.g., M/I/75/C/75 for males and F/I/75/C/75 for females). The identification would be either stitched in, stamped, or have a pressure-sensitive label, or a combination thereof. The identification typically is enclosed in a border and placed on either the surface of the tongue, gusset, shaft, or quarter lining.

### 5. PROCEDURE

A hazard assessment shall determine affected personnel and specific job duties that require the use of protective footwear. Table 1 provides the footwear protection requirements for the work being performed. Table 1 shall be updated as conditions change.



**Health, Safety and Environmental Standard**

|                               |                            |   |
|-------------------------------|----------------------------|---|
| Effective Date:<br>06/01/2016 | <b>Protective Footwear</b> | Standard Number:<br><b>HSE 4200.020</b> |
| Supersedes:<br>04/05/2010     |                            | Page 3 of 4                             |

**Table 1. Footwear Protection Requirements**

| Work Being Performed   | Pronounced Heel | <sup>1</sup> Over the Ankle/ Full Tie | 100% Leather Upper | Slip Resistant Sole | Hard Toe |
|--|-----------------|---------------------------------------|--------------------|---------------------|----------|
| Gas Distribution Plant/Construction Work   | X               | X                                     | X                  | X                   | X        |
| Fleet Mechanics  | X               | X                                     | X                  | X                   | X        |
| Building Maintenance Work/Custodians   | X               | X                                     | X                  | X                   |          |
| Gas Systems Operations Work  | X               | X                                     | X                  | X                   | X        |
| Gas Customer Service Work  | X               | X                                     | X                  | X                   |          |
| Meter Reader Work  | X               | X                                     |                    | X                   |          |
| Meter Shop Work  |                 | X                                     | X                  | X                   | X        |
| Warehouse Operation Work   | X               | X                                     | X                  | X                   | X        |
| Fabrication Operation Work   | X               | X                                     | X                  | X                   | X        |
| Leak Inspection Work   | X               | X                                     |                    | X                   |          |
| Locating Work  | X               | X                                     | X                  | X                   |          |
| <sup>2</sup> Leadership/Support (Engineering, Auditors, Land Agents, etc.)   | X               | X                                     | X                  | X                   |          |
| <sup>1</sup> Wellington style pull-on boot is acceptable.<br><sup>2</sup> If field work is being performed, refer to above requirements. |                 |                                       |                    |                     |          |

Employees who cannot wear protective footwear for medical reasons will be provided alternative foot protection. The employee must bring a written statement from a physician indicating this prohibition and any reasonable accommodations.

Protective footwear is not required in administrative or clerical type settings.

Employees operating power tools such as hand held paving breakers (jackhammers), tampers and pneumatic spades shall wear approved metatarsal guards in addition to hard-toed protective footwear.

Consideration for add-on external footwear devices (e.g., grippers, shoe-skids) shall be given to those situations that expose employees to icy/slippery surfaces.



**Distribution Operations**

**Health, Safety and Environmental Standard**

|                               |                            |   |
|-------------------------------|----------------------------|---|
| Effective Date:<br>06/01/2016 | <b>Protective Footwear</b> | Standard Number:<br><b>HSE 4200.020</b> |
| Supersedes:<br>04/05/2010     |                            | Page 4 of 4                             |

**6. TRAINING**

Employees identified in Table 1 shall participate in Personal Protective Equipment (PPE) training. This program will address the avoidance of foot hazards and the guidance contained within this standard.

Refresher training shall be conducted at least every three (3) years.

**7. RECORDS**

All training sessions and dates of training shall be documented and recorded in the NiSource Learning Management System (LMS).

**8. DEFINITIONS**

Not applicable.



## Health, Safety and Environmental Standard

### Distribution Operations

|                               |                                |   |
|-------------------------------|--------------------------------|---|
| Effective Date:<br>04/01/2011 | <b>Eye And Face Protection</b> | Standard Number:<br><b>HSE 4200.030</b> |
| Supersedes:<br>NA             |                                | Page 1 of 6                             |

Companies Affected:

|                                     |   |   |
|-------------------------------------|---|---|
| <input type="checkbox"/> NIPSCO     | <input checked="" type="checkbox"/> CGV | <input checked="" type="checkbox"/> CMD |
| <input type="checkbox"/> NIFL       | <input checked="" type="checkbox"/> CKY | <input checked="" type="checkbox"/> COH |
| <input type="checkbox"/> Kokomo Gas | <input checked="" type="checkbox"/> CMA | <input checked="" type="checkbox"/> CPA |

**REFERENCE** Code of Federal Regulations - Title 29 - (OHS) Part 1910.133 and Part 1926 Subpart E, 1926.102

## 1. GENERAL

The Company issued eye and face protection equipment is one of several articles of personal protective equipment that provides employees a margin of safety during the course of their normal activities. This provides the means of protecting employees from eye and face injury from airborne particles, toxic chemicals or gases, protruding objects, etc.

This procedure recognizes the need for angular, frontal and optical radiation protection. However, personal eye and face protective devices alone should not be relied on to provide complete protection against hazards, but should be used in conjunction with engineering controls such as machine guards and sound field operating practices.

The "NiSource Prescription Safety Eyewear Program" corporate policy establishes guidelines for employee eligibility for purchasing prescription safety glasses.

## 2. AREAS OF RESPONSIBILITY

### 2.1 Company Responsibility

The Company shall provide and require the wearing of eye/face protective equipment wherever and whenever there is a reasonable probability that an eye or face injury can be prevented by its use. The Company is also responsible for assuring that Company furnished or employee furnished protective equipment meets currently applicable standards.

### 2.2 Leader/Supervisor Responsibility

Each supervisor of employees who perform duties that may expose them to potential eye/face injury hazards shall:

- a. ensure the appropriate type(s) of protective devices from Exhibit A are available;
- b. ensure that all affected employees are informed of the eye/face hazards determined and the specific type(s) of equipment that will afford protection for the various applications;

*This document is considered CONTROLLED only when viewed electronically on the Company's intranet. Printed or other electronic copies may not be current, and the intranet version should be used to verify.*



**Distribution Operations**

**Health, Safety and Environmental Standard**

|                               |                                |   |
|-------------------------------|--------------------------------|---|
| Effective Date:<br>04/01/2011 | <b>Eye And Face Protection</b> | Standard Number:<br><b>HSE 4200.030</b> |
| Supersedes:<br>NA             |                                | Page 2 of 6                             |

- c. monitor effectiveness and enforce policy provisions, taking appropriate action necessary to ensure compliance.

**2.3 Employee Responsibility**

Employees shall wear the type(s) of devices recommended in Exhibit A for protection against eye/face injuries on any job where it has been determined by the supervisor or by personal observation that an eye injury could be prevented by the use of such equipment. It shall be the responsibility of each affected employee to guard against equipment damage and to immediately report to the supervisor any condition that impairs vision or reduces the protective characteristics (i.e., loose, broken or missing parts, scratched or pitted lenses, etc.).

**3. WEARING REQUIREMENTS**

Employees performing tasks or in working environments where there is danger of eye and face injury shall wear approved eye and face protective equipment. Exhibit A provides guidance on activities that require eye and face protection and types of protective devices.

**4. GENERAL TYPES OF EYE AND FACE PROTECTORS**

There are many types of eye and face protection products available to protect a worker. See Exhibit A. Some of the commonly available eye and face protectors used by the Company are detailed in Sections 4.1 and 4.2.

**4.1 Primary Protective Devices**

**4.1.1 Operations Which May Require Primary Protective Devices**

Some examples of operations which may require primary protective devices are:

- a. using a power tool or manual hand tool, such as a chisel;
- b. performing overhead work;
- c. assisting with welding operations;
- d. working with pressurized or compressed gases, including air;
- e. working in any environment where airborne particles may be present;
- f. working with hazardous chemicals.

Refer to the HSE 4200 series of procedures for workplace assessment and personal protective equipment requirements.



**Distribution Operations**

**Health, Safety and Environmental Standard**

|                               |                                |   |
|-------------------------------|--------------------------------|---|
| Effective Date:<br>04/01/2011 | <b>Eye And Face Protection</b> | Standard Number:<br><b>HSE 4200.030</b> |
| Supersedes:<br>NA             |                                | Page 3 of 6                             |

**4.1.2 Spectacles**

Spectacles (ANSI approved safety glasses) are protective devices intended to shield the wearer's eyes from a variety of hazards. Spectacles are commonly used to provide primary protection from impact and optical radiation. While they are primary protectors and may be used alone, they may also be required in conjunction with other protectors.

A spectacle commonly consists of the following major components: front with bridge area; lens or lenses; temples; and side shields. The assembled devices are available in many combinations of the various major component types to provide the user with a wide choice of suitable equipment. Spectacles provided by the Company will provide front and permanent top and side protection.

**4.1.3 Goggles**

Goggles are primary protective devices intended to fit the face immediately surrounding the eyes in order to shield the eyes from a variety of hazards. While they are primary protectors and may be used alone, they may also be used in conjunction with other protectors.

Goggles commonly are available in two styles: eyecup, to cover the eye sockets completely; and cover, which may be worn over spectacles. Goggles are commonly available with rigid or flexible frames, and are usually ventilated to allow passage of air to minimize fogging. The devices are available in many configurations.

**4.2 Secondary Protective Devices**

**4.2.1 Operations Which May Require Secondary Protective Devices**

Some examples of operations which may require secondary protective devices:

- a. grinding;
- b. mixing chemicals;
- c. being in the presence of pressurized or compressed gasses and air.

Refer to the HSE 4200 series of procedures for workplace assessment and personal protective equipment requirements.

**4.2.2 Face Shields**

Face shields are protective devices generally intended to shield the wearer's face or portions thereof, in addition to the eyes from certain hazards. Face shields are secondary protectors and shall be used only with primary



**Distribution Operations**

**Health, Safety and Environmental Standard**

|                               |                                |   |
|-------------------------------|--------------------------------|---|
| Effective Date:<br>04/01/2011 | <b>Eye And Face Protection</b> | Standard Number:<br><b>HSE 4200.030</b> |
| Supersedes:<br>NA             |                                | Page 4 of 6                             |

protectors. A face shield is required to be worn as a secondary protective device when performing grinding operations.

Face shields may have a head gear that supports a window, curved to surround and cover the wearer's face. Neck and chin protectors are also available. The head gear assembly may be provided with or without a crown protector. Face shield windows may be attached to protective helmets (hard hats) in place of their own head gear. The assembled devices are available in many combinations of the various major component types to provide the user with a wide choice of suitable equipment.

**4.2.3 Welding Helmets**

Welding helmets are protective devices intended to shield the eyes and face from optical radiation and airborne particulate. Welding helmets are secondary protectors and shall be used only in conjunction with primary protectors.

Filter lenses shall meet the requirements of [HSE 4120.010](#), "Welding and Cutting Safety." The helmet may be mounted on a hard hat with special accessories. Welding helmets shall be constructed of heat resistant material. There are three types commonly available: stationary lens; lift-front; and handshield.

**5. CONTACT LENSES**

Contact lenses are not recommended for use by operating employees for wear during work. Dust, foreign particles, or chemicals may become trapped beneath contact lenses causing cornea damage. If contact lenses are worn during operations that present a hazard from dust, foreign particles, or chemicals, then soft side chemical splash goggles must also be worn. In compliance with the appropriate OSHA regulation, the wearing of contact lenses in contaminated atmospheres with a respirator shall not be allowed.





**Distribution Operations**

**Health, Safety and Environmental Standard**

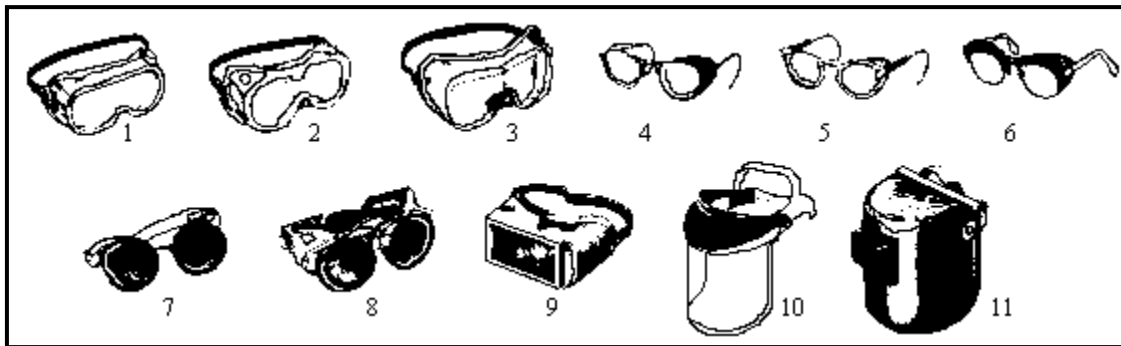
|                               |                                |   |
|-------------------------------|--------------------------------|---|
| Effective Date:<br>04/01/2011 | <b>Eye And Face Protection</b> | Standard Number:<br><b>HSE 4200.030</b> |
| Supersedes:<br>NA             |                                | Page 5 of 6                             |

**EXHIBIT A  
(1 OF 2)**

| <b>Applications</b>   |  |   |
|---|--|---|
| <b>Operation</b>  | <b>Hazards</b>                                       | <b>Recommended Protectors</b>                                       |
| Acetylene-Burning<br>Acetylene-Cutting<br>Acetylene-Welding | Sparks, harmful rays, molten metal, flying particles | 7, 8, 9   |
| Chemical Handling   | Splash, acid burns, fumes                            | 2, 10 (For severe exposure add 10 over 2)                           |
| Chipping  | Flying particles                                     | 1, 3, 4, 5, 6, 7A, 8A   |
| Electric (arc) welding                                      | Sparks, intense rays, molten metal                   | 9, 11, (11 in combination with 4, 5, 6, in tinted lenses advisable) |
| Furnace operations  | Glare, heat, molten metal                            | 7, 8, 9 (For severe exposure add 10)                                |
| Grinding-Light  | Flying particles                                     | 1, 3, 4, 5, 6, and 10 shall be worn as a secondary protector        |
| Grinding-Heavy  | Flying particles                                     | 1, 3, 7A, 8A and 10 shall be worn as a secondary protector          |
| Laboratory  | Chemical splash, glass breakage                      | 2 (10 when in combination with 4, 5, 6)                             |
| Machining   | Flying particles                                     | 1, 3, 4, 5, 6, 10   |
| Molten metals   | Heat, glare, sparks, splash                          | 7, 8, (10 in combination with 4, 5, 6, in tinted lenses)            |
| Spot welding  | Flying particles, sparks                             | 1, 3, 4, 5, 6, 10   |

|                               |                                |   |
|-------------------------------|--------------------------------|---|
| Effective Date:<br>04/01/2011 | <b>Eye And Face Protection</b> | Standard Number:<br><b>HSE 4200.030</b> |
| Supersedes:<br>NA             |                                | Page 6 of 6                             |

**EXHIBIT A  
 (2 OF 2)**



|     |  |  |
|-----|--|--|
| 1.  | GOGGLES  | Flexible Fitting - Regular Ventilation     |
| 2.  | GOGGLES  | Flexible Fitting - Hooded Ventilation      |
| 3.  | GOGGLES  | Cushioned Fitting - Rigid Body             |
| 4.  | SPECTACLES   | Metal Frame, with Sideshields (1)          |
| 5.  | SPECTACLES   | Plastic Frame - with Sideshields (1)       |
| 6.  | SPECTACLES   | Metal-Plastic Frame - with Sideshields (1) |
| 7.  | WELDING GOGGLES  | Eyecup Type - Tinted Lenses (2)            |
| 7A. | CHIPPING GOGGLES   | Eyecup Type - Clear Safety Lenses          |
| 8.  | WELDING GOGGLES  | Coverspec Type - Tinted Lenses (2)         |
| 8A. | CHIPPING GOGGLES   | Coverspec Type - Clear Safety Lenses       |
| 9.  | WELDING GOGGLES  | Coverspec Type - Tinted Plate Lens (2)     |
| 10. | FACE SHIELD  | (Available with Plastic or Mesh Window)    |
| 11. | WELDING HELMETS (2)  |  |
|     | (1) Non-side shield spectacles are available for limited hazard use requiring only frontal protection. |  |
|     | (2) See HSE 4120.010 Section 5.2 for Filter Lens Shade Numbers for Protection Against Radiant Energy.  |  |



**Distribution Operations**

**Health, Safety and Environmental Standard**

|                               |                        |  |
|-------------------------------|------------------------|--|
| Effective Date:<br>08/04/1995 | <b>Hand Protection</b> | Standard Number:<br><b>HSE 4200.040(CG)</b><br>P&P 425-9 |
| Supersedes:<br>N/A            |                        | Page 1 of 2  |

Companies Affected:

|                                     |   |   |
|-------------------------------------|---|---|
| <input type="checkbox"/> NIPSCO     | <input checked="" type="checkbox"/> CGV | <input checked="" type="checkbox"/> CMD |
| <input type="checkbox"/> NIFL       | <input checked="" type="checkbox"/> CKY | <input checked="" type="checkbox"/> COH |
| <input type="checkbox"/> Kokomo Gas | <input type="checkbox"/> CMA            | <input checked="" type="checkbox"/> CPA |

**REFERENCE** Code of Federal Regulations - Title 29 - Part 1980.138

**1. GENERAL**

The Company requires the wearing of hand protection where there is a reasonable probability that injury/illness could result from burns, cuts, minor impact, exposure to corrosive or irritating materials or bloodborne pathogens.

**2. AREAS OF RESPONSIBILITY**

**2.1 Company Responsibility**

The Company shall provide and require the wearing of hand protection wherever and whenever there is reasonable probability that a hand injury can be prevented by its use.

**2.2 Supervisor Responsibility**

Each supervisor of employees who perform duties that may expose them to potential hand injury hazards shall:

- a. Inform all affected employees of the requirements for hand protection; and
- b. Monitor effectiveness and enforce policy provisions, taking appropriate action necessary to ensure compliance.

**2.3 Employee Responsibility**

- a. Employees shall wear the type(s) of hand protection required in Section 3 for their protection against hand injuries on any job where a hand injury could be prevented by the use of such equipment.
- b. Employees shall exercise reasonable care and maintenance for all Company issued hand protection.

**2.4 Safety and Health Specialist Responsibility**

- a. It is the responsibility of the District Safety and Health Specialist to monitor

*This document is considered CONTROLLED only when viewed electronically on the Company's intranet. Printed or other electronic copies may not be current, and the intranet version should be used to verify.*



**Distribution Operations**

**Health, Safety and Environmental Standard**

|                               |                        |  |
|-------------------------------|------------------------|--|
| Effective Date:<br>08/04/1995 | <b>Hand Protection</b> | Standard Number:<br><b>HSE 4200.040(CG)</b><br>P&P 425-9 |
| Supersedes:<br>N/A            |                        | Page 2 of 2  |

the effectiveness of the selected hand protection to prevent injuries.

- b. In those cases where the pre-selected hand protection does not meet the specific/special need, it is the responsibility of the District Safety and Health Specialist to determine the appropriate hand protection required for that specific task.

**3. TYPES OF GLOVES**

The following table indicates typical applications and the glove type required to perform the application:

| APPLICATION  | TYPE                            |
|--|---------------------------------|
| First aid<br>First aid training                                      | Latex-examination               |
| Chemical exposures<br>as indicated<br>per Material Safety Date Sheet | Impermeable with<br>Gauntlet    |
| Welder and/or Helper   | Welder's Glove with<br>Gauntlet |
| Normal operations as job<br>requires                                 | Cotton or Leather               |

Refer to the HSE 4200 series of procedures for workplace assessment and personal protective equipment requirements.



Distribution Operations

## Health, Safety and Environmental Standard

|                              |                          |   |
|------------------------------|--------------------------|---|
| Effective Date:<br>7/01/2013 | <h1>Head Protection</h1> | Standard Number:<br><b>HSE 4200.050</b> |
| Supersedes:<br>N/A           |                          | Page 1 of 3                             |

Companies Affected:

|                                 |   |   |
|---------------------------------|---|---|
| <input type="checkbox"/> NIPSCO | <input checked="" type="checkbox"/> CGV | <input checked="" type="checkbox"/> CMD |
|                                 | <input checked="" type="checkbox"/> CKY | <input checked="" type="checkbox"/> COH |
|                                 | <input checked="" type="checkbox"/> CMA | <input checked="" type="checkbox"/> CPA |

**REFERENCE** Code of Federal Regulations - Title 29 - Part 1926  
Code of Federal Regulations - Title 29 - Part 1910.135  
ANSI - 289.1 and ANSI - 289.2

### 1. GENERAL

The Company issued protective helmet (hard hat) is one of several articles of personal protective equipment that provides employees a margin of safety during the course of their normal activities. The hard hat also provides Company identification and a positive image for employees.

### 2. USE REQUIREMENTS

Employees working in areas where there is danger of head injury from impact, falling or flying objects, or from electrical shock or burns shall be protected with approved helmets (hard hats). The head protection shall be worn in the manner as intended by the manufacturer (i.e., bill shall be worn in front and suspension intact).

#### 2.1 Required Use Areas

These areas include but not limited to the following conditions:

- a. For employees working at construction or maintenance sites where excavation activities are taking place or at locations where overhead work is occurring and wearing a helmet could reasonably be expected to prevent head injury from a falling object.
- b. For employees working in material storage areas where materials are stored at eye level or above.
- c. For visitors (e.g., Managers, Supervisors, Inspectors, etc.) at the sites described in "a" and "b" above.
- d. Where required by others (e.g., contractors, governmental agencies, industrial plants, etc.).
- e. In areas where the supervisor has designated that the wearing of the helmet is appropriate.
- f. In any area where an employee believes head protection is needed.

*This document is considered CONTROLLED only when viewed electronically on the Company's intranet. Printed or other electronic copies may not be current, and the intranet version should be used to verify.*



## Health, Safety and Environmental Standard

|                              |                        |   |
|------------------------------|------------------------|---|
| Effective Date:<br>7/01/2013 | <b>Head Protection</b> | Standard Number:<br><b>HSE 4200.050</b> |
| Supersedes:<br>N/A           |                        | Page 2 of 3                             |

### 2.2 Bump Caps

Bump caps may be utilized when employees who are not issued helmets and are not subject to the requirements of Section 2.1 desire some protection from bumps and scrapes. Bump caps will not be issued for occasional use when helmets have already been provided.

### 3. GENERAL PROTECTION PRECAUTIONS

The impact protecting ability of a helmet depends on the amount of shock absorbing space created between the shell and suspension system. This space must not be altered.

Manufacturer's approved winter liners offer comfort in cold environments without negating the protective properties. Wearing baseball caps, parkas, stocking caps etc., between the helmet and the head is prohibited. Employees exposed to electrical hazards shall not wear winter liners which contain metal zippers, snaps, etc.

Manufacturer's approved sweat-band liners offer comfort in hot environments without negating the protective properties.

### 4. CARE OF HELMETS

A visual inspection of the helmet shall be performed frequently by employees for signs of damage due to impact, rough treatment or wear that could reduce head protection. Any helmet requiring repair shall be removed from service. Damaged helmets shall not be returned to service until worn, damaged or defective parts have been replaced.

Helmet suspension systems are not interchangeable. Use only those authorized by the manufacturer.

Helmets shall not be painted.

Helmets shall not be altered by drilling holes or modifying the equipment.

An acceptable method of cleaning the shell is by washing with water and a detergent. After washing, wipe dry and inspect for damage.

Tars, paints, oils and other adherent dirt should be removed with non-flammable and/or non-toxic solvents, such as waterless hand cleaner.

If helmets are to be marked, care should be taken to ensure that the marking does not, in any way, affect the strength of the hat. Helmets may be marked with some kind of adhesive decal or tape. The shell shall not be cut or engraved.

Helmets transported in vehicles shall be stored in a rack or otherwise secured. Avoid storing or transporting helmets where they are exposed to direct sunlight. Helmets shall not



## Health, Safety and Environmental Standard

|                              |                        |   |
|------------------------------|------------------------|---|
| Effective Date:<br>7/01/2013 | <b>Head Protection</b> | Standard Number:<br><b>HSE 4200.050</b> |
| Supersedes:<br>N/A           |                        | Page 3 of 3                             |

be stored or carried on the rear window shelf of vehicles.

### 5. AREAS OF RESPONSIBILITY

#### 5.1 Company Responsibility

The Company shall provide and require the wearing of head protection equipment wherever and whenever there is a reasonable probability that a head injury can be prevented by its use. The Company is responsible for ensuring that Company furnished protective equipment meets currently applicable standards.

#### 5.2 Supervisor Responsibility

Each supervisor of employees who perform duties that may expose them to potential head injury shall:

- a. Inform all affected employees of the requirements for head protection; and
- b. Monitor effectiveness and enforce policy provisions, taking appropriate action necessary to ensure compliance.

#### 5.3 Employee Responsibility

Employees shall wear the type of protection required for protection against head injuries on any job where a head injury could be prevented by the use of such equipment. It shall be the responsibility of each affected employee to guard against equipment damage and to immediately report to the supervisor any condition that impairs or reduces its protective characteristics.

#### 5.4 Contractor Responsibility

Contractor personnel are subject to the same OSHA safety helmet requirements as NiSource employees. The responsibility for compliance, including providing head protection and information to affected contractor personnel, rests with the contractor or the contractor's authorized representative.



## Health, Safety and Environmental Standard

### Distribution Operations

|                               |                              |   |
|-------------------------------|------------------------------|---|
| Effective Date:<br>07/01/2014 | <b>Driver Qualifications</b> | Standard Number:<br><b>HSE 4300.010</b> |
| Supersedes:<br>01/01/2013     |                              | Page 1 of 6                             |

Companies Affected:

|                                 |   |   |
|---------------------------------|---|---|
| <input type="checkbox"/> NIPSCO | <input checked="" type="checkbox"/> CGV | <input checked="" type="checkbox"/> CMD |
|                                 | <input checked="" type="checkbox"/> CKY | <input checked="" type="checkbox"/> COH |
|                                 | <input checked="" type="checkbox"/> CMA | <input checked="" type="checkbox"/> CPA |

**REFERENCE** 49 CFR Parts 380 - 393

### 1. PURPOSE

This document is to establish driver qualification criteria for all NiSource Gas Distribution (NGD) employees.

### 2. DEFINITIONS

**Safe Driver Program** - The Safe Driver Program is a comprehensive approach to reduce exposure to collisions and ensure safe driving at NiSource Gas Distribution (NGD). These strategies are documented in the Safe Driver Program and include responsibilities, driver eligibility, training, education and evaluation, reporting and collision investigation.

**Motor Vehicle Record (MVR)** – a record of an individual's driving history in the state that the individual is licensed in.

### 3. SCOPE

This document applies to all NGD employees who drive personal, rental or Company vehicles while conducting business on behalf of the Company.

### 4. RESPONSIBILITIES

#### 4.1 Employee

The employee is responsible for the following.

- a. Maintain a valid driver's license that meets all requirements for the type of vehicle they will be driving.
- b. Notifying Supervisor immediately upon loss or suspension of driving privileges.
- c. Wear seat belt at all times while driving and require any passengers to do the same.
- d. Do not use MDTs while driving.
- e. Follow the NiSource Use of Cellular Telephones and Electronic Devices

*This document is considered CONTROLLED only when viewed electronically on the Company's intranet. Printed or other electronic copies may not be current, and the intranet version should be used to verify.*





**Distribution Operations**

**Health, Safety and Environmental Standard**

|                               |                              |   |
|-------------------------------|------------------------------|---|
| Effective Date:<br>07/01/2014 | <b>Driver Qualifications</b> | Standard Number:<br><b>HSE 4300.010</b> |
| Supersedes:<br>01/01/2013     |                              | Page 2 of 6                             |

Policy (Note - Frontline employees shall not use cellular telephones while driving).

- f. It is the responsibility of all Personnel to ensure that using a cellular telephone or other electronic device does not interfere with the safe operation of their vehicle.
- g. Follow the Company's parking policy, pull through or back in when possible, always perform a 360 walk around and use cones or other approved devices where required (see Section 5.9).
- h. Follow unattended vehicle requirements.
- i. Perform and document pre- and post-use inspections on Commercial Motor Vehicles.
- j. Report all collisions or maintenance issues to leader/supervisor.
- k. Maintain an acceptable Motor Vehicle Record (MVR) as established in HSE 4300.030 (regulated vehicles) or HSE 4300.032 (non-regulated vehicles).

**4.2 Leader/Supervisor**

The local leader/supervisor is responsible for the following.

- a. Ensure that employees have a valid driver's license and meet the DOT requirements for the type of vehicle they will be driving.
- b. Ensure employees receive required driver training.
- c. Ensure employees have reviewed and are familiar with this policy and the NGD Safe Driver Program.
- d. Ensure all new employees receive required driver training prior to the operation of a vehicle on the Company's behalf and conduct evaluations within the first six (6) months of employment.
- e. Ensure all incidents are reported.
- f. Ensure a root cause investigation and corrective actions are completed for all preventable vehicle collisions.
- g. Identifying and securing for their employees a "hands free accessory" if applicable.
- h. Enforcing the requirements of this standard.
- i. Ensure employees maintain an acceptable Motor Vehicle Record (MVR) as establish in HSE 4300.030 (regulated vehicles) or HSE 4300.032 (non-regulated vehicles).

**4.3 HSE Department**

The HSE Department is responsible for the following.



**Distribution Operations**

## Health, Safety and Environmental Standard

|                               |                              |   |
|-------------------------------|------------------------------|---|
| Effective Date:<br>07/01/2014 | <b>Driver Qualifications</b> | Standard Number:<br><b>HSE 4300.010</b> |
| Supersedes:<br>01/01/2013     |                              | Page 3 of 6                             |

- a. Participate in root cause investigation, collision analysis and corrective action plans.
- b. Provide or coordinate driver training.
- c. Analyze MVRs annually in accordance with the NGD Safe Driver Program.
- d. Evaluate and monitor effectiveness of the NGD Safe Driver Program.

### 5. PROCEDURE

#### 5.1 Requirements

Employees operating a vehicle or other equipment on the Company's behalf must maintain a valid operator's license to operate the type and size of equipment to which they are assigned. In the event an employee's driving privileges are revoked or suspended, they must report it to their leader/supervisor immediately.

#### 5.2 DOT Requirements

Any driver who is subject to the U.S. Department of Transportation Motor Carrier Safety Regulations shall meet all DOT requirements before being permitted to drive.

#### 5.3 Qualifying Company Drivers

The following shall be accomplished when qualifying employees to operate any vehicle on the Company's behalf.

- a. Each leader/supervisor shall verify that an employee has a valid state operator's license, at least annually, for the type(s) of vehicle(s) to be operated.
- b. An employee who is eligible to drive a vehicle on the Company's behalf may be required to satisfactorily pass a physical examination or vision test at any time the Company has reason to doubt the employee's physical capability to safely operate a vehicle.
- c. Secure and review a Motor Vehicle Record (MVR) on each direct report employee who drives on Company business annually.
- d. Ensure driver training is conducted prior to the operation of a vehicle on the Company's behalf.

#### 5.4 Seat Belt Requirements

Every employee who drives or is a passenger in a vehicle operated on the Company's behalf shall wear a seat belt or harness provided in the vehicle. Seat belts or harnesses that are inoperable or in poor condition shall be repaired or replaced. Alterations to seat belts or harnesses are not permitted.



**Distribution Operations**

## Health, Safety and Environmental Standard

|                               |                              |   |
|-------------------------------|------------------------------|---|
| Effective Date:<br>07/01/2014 | <b>Driver Qualifications</b> | Standard Number:<br><b>HSE 4300.010</b> |
| Supersedes:<br>01/01/2013     |                              | Page 4 of 6                             |

### 5.5 Cell Phone and Electronic Devices Requirements

All Personnel must comply with the following guidelines.

- a. Avoid the use of cellular telephones while driving.
  1. Frontline employees shall not use cellular telephones while driving.
  2. All calls should be made when parked in a safe location.
  3. Vehicle operators should allow passengers to answer phone calls.
- b. If the use of a cellular telephone while operating a motor vehicle cannot be avoided, only telephones equipped with a hands-free accessory may be used.
  1. The hands-free accessory must allow both hands to be kept on the wheel and minimize or prevent distractions caused by use of the cellular telephone.
  2. Cellular telephones or other electronic devices not equipped with the hands-free equipment may only be used while operating a motor vehicle in emergency situations, if permitted by law.
- c. Texting, checking e-mail, or accessing the internet is prohibited by all employees while driving a motor vehicle.
- d. Laptops and Mobile Data Terminals (MDT's) shall be kept secured and in the closed position while the vehicle is being driven.
- e. Global Positioning Systems (GPS's) or other navigational devices shall not be programmed by the driver while the vehicle is in motion. Programming or reprogramming shall be done only when the vehicle is parked in a safe location.
- f. No punitive actions shall be taken against Personnel who are unable to receive or make a call when driving a vehicle.

### 5.6 Unattended Vehicles

Vehicles operated on the Company's behalf shall not be left unattended until the motor is stopped, the key removed and the vehicle locked. Wheels must be chocked in the following instances.

- a. When the vehicle is used as a power supply.
- b. During loading and unloading of wheeled and tracked equipment.
- c. Any Commercial Motor Vehicle on uneven terrain.

### 5.7 Compliance with the Law

Every employee operating a vehicle on the Company's behalf has the responsibility of



**Distribution Operations**

**Health, Safety and Environmental Standard**

|                               |                              |   |
|-------------------------------|------------------------------|---|
| Effective Date:<br>07/01/2014 | <b>Driver Qualifications</b> | Standard Number:<br><b>HSE 4300.010</b> |
| Supersedes:<br>01/01/2013     |                              | Page 5 of 6                             |

complying with all Federal, State and local regulations and Company policies concerning traffic regulations. Any fines incurred, for parking or moving violations, shall be the responsibility of the employee.

**5.8 Vehicle Housekeeping**

The exterior of Company vehicles shall be kept clean and free of unauthorized signs and markings. Authorized signs and markings are only those provided by the Company and specified for use on Company vehicles. The interior of Company vehicles shall be kept clean and free of unnecessary material. Equipment shall be stored and secured in a safe and orderly manner.

**5.9 BackingParking**

All vehicles operated on the Company's behalf or personal vehicles on Company facilities should avoid backing whenever possible. The first choice shall always be locating a pull-through space. If there are no pull-through spaces available, the driver should locate a suitable space and back in upon arrival. Exceptions are, but not limited to: angle parking, or other such circumstances where pulling through or backing into a parking space is prohibited. Consideration should be given to avoid these exceptions when practical.

Curbside parking shall be the first choice when parking at a customer's residence. If there are no safe options curbside, backing into a customer's driveway can be an alternative parking solution. When parking in a customer's driveway, back only as far as necessary to get the vehicle off the roadway. Parking a vehicle in a safe location should always take precedence over parking for convenience.

When backing a vehicle operated on the Company's behalf, if another employee is available, that employee shall direct the driver while backing.

Never back at/or into an intersection.

Prior to backing turn off all radios and tap the horn to warn others.

Before moving any vehicle operated on the Company's behalf from its parked position, the driver shall perform a 360° walk around of the vehicle making certain there is sufficient clearance and that the area is free of obstacles.

The 360° walk around shall be augmented by the use of cones or other suitable reminders of the walk around requirement. The use of a cone or other suitable device is not required for short-term rental vehicles.

**5.10 Motorcycles**

Use of a motorcycle on Company business is prohibited.



**Distribution Operations**

**Health, Safety and Environmental Standard**

|                               |                              |   |
|-------------------------------|------------------------------|---|
| Effective Date:<br>07/01/2014 | <b>Driver Qualifications</b> | Standard Number:<br><b>HSE 4300.010</b> |
| Supersedes:<br>01/01/2013     |                              | Page 6 of 6                             |

**6. TRAINING**

**6.1 Initial Driver Training**

Leaders/supervisors who hire a new employee must contact HSE to arrange for initial training prior to the operation of a vehicle on the Company's behalf. A complete overview of the training programs offered is available in the NGD Safe Driver Program.

**6.2 Driver Retraining**

Any driver responsible for a preventable vehicle collision shall participate in a driver retraining program as outlined in the NGD Safe Driver Program.

Employees with an MVR indicating a medium or high risk driver is subject to further training.

**6.3 Other Driver Training**

Additional driver training is available for all Company drivers. Information relating to programs may be obtained from local HS&E Coordinators.



Distribution Operations

## Health, Safety and Environmental Standard

|                               |                                   |   |
|-------------------------------|-----------------------------------|---|
| Effective Date:<br>07/01/2011 | <b>Vehicle Incident Reporting</b> | Standard Number:<br><b>HSE 4300.020</b> |
| Supersedes:<br>04/01/2011     |                                   | Page 1 of 4                             |

Companies Affected:

|                                 |   |   |
|---------------------------------|---|---|
| <input type="checkbox"/> NIPSCO | <input checked="" type="checkbox"/> CGV | <input checked="" type="checkbox"/> CMD |
|                                 | <input checked="" type="checkbox"/> CKY | <input checked="" type="checkbox"/> COH |
|                                 | <input checked="" type="checkbox"/> CMA | <input checked="" type="checkbox"/> CPA |

### 1. PURPOSE

This procedure outlines the requirements for the prompt reporting of motor vehicle incidents that involve NiSource distribution operations employees.

### 2. SCOPE

This procedure is applicable to NiSource distribution operations personnel who are driving Company, rental or personal vehicles on Company business and employees commuting in Company vehicles with appropriate leader/supervisor authorization.

### 3. RESPONSIBILITIES

#### 3.1 Employee

Employees must report all motor **vehicle incidents** to their leader/supervisor or designee and the NiSource Claim Reporting Hotline as soon as possible on the day of the motor vehicle incident.

#### 3.2 Leader/Supervisor

Leaders/supervisors shall ensure that following a motor vehicle incident, the incident is reported to the NiSource Claim Reporting Hotline. Leaders/supervisors are responsible to review incidents and when possible draft a plan to reduce the possibility of reoccurrence.

#### 3.3 HSE Department

HSE department designee(s) shall, where appropriate, assist in development and implementation of plans developed by employees and leaders/supervisors to reduce the possibility of reoccurrence of the motor vehicle incident.

### 4. PROCEDURE

#### 4.1 Employee

The employee should obtain as much information as is available while at the scene of the incident, including personal injuries, property damage to others, witnesses, incident conditions, insurance information, diagram of incident, and a police report. The Auto Accident Guide (aka, "3 Easy Steps to Help You After an Accident" brochure) is a good

*This document is considered CONTROLLED only when viewed electronically on the Company's intranet. Printed or other electronic copies may not be current, and the intranet version should be used to verify.*



Distribution Operations

## Health, Safety and Environmental Standard

|                               |                                   |   |
|-------------------------------|-----------------------------------|---|
| Effective Date:<br>07/01/2011 | <b>Vehicle Incident Reporting</b> | Standard Number:<br><b>HSE 4300.020</b> |
| Supersedes:<br>04/01/2011     |                                   | Page 2 of 4                             |

guide and instrument to use in collecting and recording this information for reporting purposes.

**NOTE:** All NiSource employees driving on Company business in Company vehicles, rental vehicles and personal vehicles must have the Auto Accident Guide (aka, "3 Easy Steps to Help You After an Accident" brochure) in their possession.

Company vehicles and rental vehicles are insured by NiSource. Employees using their personal vehicles on Company business are required to insure their own vehicles in compliance with state law. The employee's vehicle insurance will be primary for liability with the Company auto liability insurance program as excess insurance. No Comprehensive or Collision coverage is provided for personal vehicles used on Company business. (This policy however will not contradict any collective bargaining agreements). All accidents while on Company business, regardless of vehicle ownership, must be reported with due diligence to Corporate Insurance via the **1-877-ENERGY4** reporting hotline.

### 4.1.1 Notification

The employee's leader/supervisor or designee must be notified immediately after the situation is made safe.

### 4.1.2 Information

The employee, along with his/her immediate leader/supervisor or designee, will gather and forward all information related to the incident to the NiSource Claim Reporting Hotline (**1-877-ENERGY4**) on the same day or within 24 hours of the incident.

**NOTE:** The NiSource Claim Administrator will direct the employee to the nearest repair facility, if appropriate.

### 4.1.3 Forms

The Company driver is responsible for submitting any forms required by law enforcement agencies where the incident occurred. The Company's insurance policy information can be found on the Company issued insurance card or by calling the NiSource Corporate Insurance Department.

**NOTE:** If the claim has been reported, any questions regarding accident forms to be submitted to law enforcement agencies can be directed to the Corporate Claims Administrator that has been assigned to your case. If necessary, the Corporate Claims Administrator will contact the Company driver.



**Distribution Operations**

## Health, Safety and Environmental Standard

|                               |                                   |   |
|-------------------------------|-----------------------------------|---|
| Effective Date:<br>07/01/2011 | <b>Vehicle Incident Reporting</b> | Standard Number:<br><b>HSE 4300.020</b> |
| Supersedes:<br>04/01/2011     |                                   | Page 3 of 4                             |

### 4.1.4 Proof of Insurance

The Company requires the following.

- a. Company vehicles must have proof of insurance in the glove box at all times. This process is managed by the corporate insurance and fleet administration groups.
- b. Proof of insurance for personal vehicles is the responsibility of the vehicle's owner.
- c. Corporate policy requires that personal vehicles used on Company business must comply with State Laws regarding minimum liability coverage. Any other coverage beyond state requirement is at the discretion of the vehicle's owner.
- d. Corporate policy is that the NiSource driver renting a vehicle should waive insurance offered through the rental agency. However, should there be an accident; you will need to show proof of insurance to the law enforcement agency with jurisdiction in that area. Therefore, it is recommended that any employee renting a car for business purposes keep a copy of their Personal insurance card in their wallet. Be advised that this is administrative in nature, as the NiSource Corporate insurance program will handle damage to the rental car or third party on a primary basis and that the personal insurance will not be involved. Due to various state laws, it is not possible to issue NiSource insurance cards to NiSource employees that have the potential to rent a vehicle.

### 4.2 Leader/Supervisor Responsibilities

The immediate leader/supervisor of the driver or the designated person acting in the absence of the leader/supervisor must immediately do the following.

- a. If the incident involves an employee injury, depending on the nature of the injury, the affected leader/supervisor will first assist the injured employee by securing appropriate medical attention and ensuring that a worksite has been returned to a safe condition.
- b. Make notification to the appropriate HSE Coordinator.
- c. Perform a Vehicle Root Cause Analysis within 14 days of the incident.

### 4.3 Other Reporting Responsibilities

All incidents reported to the NiSource Insurance Vendor will be reviewed to determine cause and will be categorized as a preventable or a non-preventable incident. Factual information obtained from Police Reports (if applicable), known mechanical failures, driver fault or issuance of citations will be used as minimum guidelines for determining





**Distribution Operations**

**Health, Safety and Environmental Standard**

|                               |                                   |   |
|-------------------------------|-----------------------------------|---|
| Effective Date:<br>07/01/2011 | <b>Vehicle Incident Reporting</b> | Standard Number:<br><b>HSE 4300.020</b> |
| Supersedes:<br>04/01/2011     |                                   | Page 4 of 4                             |

preventable or non-preventable status. Additional information will be obtained from the driver and any other available sources. A preventability determination may be appealed by following the process established in the Safe Driver Program manual. All incidents will be documented and the information will be used as benchmarking data by NiSource. A complete list of all documented incidents will be maintained by the Corporate Insurance Department.

**5. TRAINING**

Training will be conducted by the HSE Department or designee and recorded in the Learning Management System (LMS).

**6. RECORDS**

Not applicable.

**7. DEFINITIONS**

**Vehicle Incident** – Any circumstance in which a vehicle operated during the course of Company business comes in contact with another vehicle, person, object or animal which results in death, personal injury or property damage.

**8. REGULATORY REFERENCES**

Not applicable.



**Distribution Operations**

**Health, Safety and Environmental Standard**

|                               |   |   |
|-------------------------------|---|---|
| Effective Date:<br>01/01/2013 | <b>Motor Vehicle Record (MVR)<br/>Review - Regulated Vehicles</b> | Standard Number:<br><b>HSE 4300.030</b> |
| Supersedes:<br>N/A            |   | Page 1 of 10                            |

Companies Affected:

|                                 |   |   |
|---------------------------------|---|---|
| <input type="checkbox"/> NIPSCO | <input checked="" type="checkbox"/> CGV | <input checked="" type="checkbox"/> CMD |
|                                 | <input checked="" type="checkbox"/> CKY | <input checked="" type="checkbox"/> COH |
|                                 | <input checked="" type="checkbox"/> CMA | <input checked="" type="checkbox"/> CPA |

**REFERENCE** Federal/State Motor Carrier Safety Regulations (Parts 390-397) latest edition and the Commercial Motor Vehicle Safety Act of 1986.

**1. SCOPE**

This policy/procedure only applies to:

- a. Applicants for employment where such employment will place applicants in a job which requires the operation of vehicles which are regulated by State or Federal Motor Carrier Safety Regulations (MCSR) and/or a vehicle covered by the Commercial Motor Vehicle Safety Act of 1986;
- b. Employees currently operating such vehicles and employees who are transferred or promoted into jobs requiring the operation of such vehicles.

**2. VEHICLES REGULATED BY THE FEDERAL/STATE MCSR (COMMERCIAL MOTOR VEHICLES)**

**2.1 Federal (Interstate)**

Vehicles and combination vehicles that have a Gross Vehicle or Combination Gross Vehicle Weight Rating above 10,000 lbs. and vehicles, regardless of GVWR, that transport hazardous materials which must be marked or placarded according to Section 177.823 of Title 49 are covered by the Federal MCSR.

**2.2 States (Intrastate)**

Drivers of Vehicles and combination vehicles that have a Gross Vehicle or Combination Gross Vehicle Weight Rating which exceed the following weight thresholds are subject to intrastate Motor Carrier Safety Regulations.

- Ohio - Above 26,000 lbs.
- Virginia - Above 26,000 lbs.
- Kentucky - Above 10,000 lbs.
- Maryland - Above 10,000 lbs.
- Pennsylvania - Above 10,000 lbs.
- Massachusetts - Above 10,000 lbs.

*This document is considered CONTROLLED only when viewed electronically on the Company's intranet. Printed or other electronic copies may not be current, and the intranet version should be used to verify.*



Distribution Operations

Health, Safety and Environmental Standard

|                               |   |   |
|-------------------------------|---|---|
| Effective Date:<br>01/01/2013 | <b>Motor Vehicle Record (MVR)<br/>Review - Regulated Vehicles</b> | Standard Number:<br><b>HSE 4300.030</b> |
| Supersedes:<br>N/A            |   | Page 2 of 10                            |

**3. VEHICLES REGULATED BY THE COMMERCIAL MOTOR VEHICLE ACT OF 1986**

Drivers of vehicles being operated interstate or intrastate that exceed 26,000 lbs. Gross vehicle or Combination Gross Vehicle Weight Rating and to any vehicle, regardless of weight, transporting hazardous materials are covered by the CMVSA of 1986.

**4. DRIVER DISQUALIFICATION PROVISIONS - MCSR**

The following disqualifying provisions apply to applicants/employees who will be expected to operate vehicles that are regulated by State or Federal Motor Carrier Safety Regulations, Parts 390-397.

**4.1 General Provisions**

A driver is disqualified for the duration of his/her loss of the privilege to operate a commercial motor vehicle on public highways, either temporarily or permanently, by reason of the revocation, suspension, withdrawal, or denial of an operator's license, permit, or privilege, until that operator's license, permit, or privilege is restored by the authority that revoked, suspended, withdrew, or denied it. The disqualifying offenses listed below may preclude an employee/applicant from operating a regulated vehicle even though a state licensing agency has restored his/her permit, license or driving privilege.

**4.2 Driver Disqualification for Criminal Offenses**

**4.2.1 General Rule**

In addition to penalties assessed by State law, a driver who is convicted of (or forfeits bond or collateral upon a charge of) a disqualifying offense specified in Section 4.2.2 is disqualified for a period of time specified in Section 4.2.3 if the offense was committed while operating a vehicle on behalf of the company.

**4.2.2 Specific Disqualifying Offenses**

The following offenses are disqualifying:

- a. operating a vehicle under the influence of alcohol, a Schedule I drug or other substance identified in Appendix II of the MCSR latest edition, an amphetamine, a narcotic drug, a formulation of an amphetamine or a derivative of a narcotic drug;
- b. transportation, possession, or unlawful use of a Schedule I drug or other substance identified in Appendix D of the MCSR, latest edition, amphetamine, or derivatives of narcotic drugs while on duty;
- c. leaving the scene of an accident which resulted in injury or death; or
- d. a felony involving the use of a motor vehicle.



**Health, Safety and Environmental Standard**

|                               |   |   |
|-------------------------------|---|---|
| Effective Date:<br>01/01/2013 | <b>Motor Vehicle Record (MVR)<br/>Review - Regulated Vehicles</b> | Standard Number:<br><b>HSE 4300.030</b> |
| Supersedes:<br>N/A            |   | Page 3 of 10                            |

**4.2.3 Duration of Disqualification for Criminal Misconduct**

- a. First Offenders - a driver is disqualified for 1 year after the date of conviction or forfeiture of bond or collateral if, during the 3 years preceding that date, the driver was not convicted of, or did not forfeit bond or collateral upon a charge of an offense that would disqualify the driver under the rules of Section 4.2.2. EXCEPTION. The period of disqualification is only 6 months if the conviction or forfeiture of bond or collateral solely concerned the transportation or possession of substances named in Section 4.2.2 (b).
- b. Subsequent Offenders - a driver is disqualified for 3 years after the date of his/her conviction or forfeiture of bond or collateral if, during the 3 years preceding that date, he/she was convicted of, or forfeited bond or collateral upon a charge of, an offense that would disqualify him/her under rules named in Section 4.2.2.

**5. COMMERCIAL MOTOR VEHICLE SAFETY ACT (CMVSA) OF 1986**

The following disqualifying provisions apply to applicants/employees who will be expected to operate vehicles that are regulated under the Commercial Motor Vehicle Safety Act of 1986.

**5.1 General Rule**

Unless changed by the Secretary, Department of Transportation, the CMVSA applies only to vehicles that exceed 26,001 lbs. gross vehicle weight (GVW) rating and to the operators of such vehicles.

**5.2 Disqualification Provisions**

**5.2.1 Major Violations**

Defined as: driving under the influence of alcohol or drugs; leaving the scene of an accident; use of a vehicle in the commission of a felony. Sanctions: first offense - 1 year (3 years if transporting hazardous materials); second offense - lifetime (may be reduced to 10 years under guidelines to be developed by Federal Department of Transportation (DOT)).

**5.2.2 Serious Violations**

Defined as: Violations associated with a fatal accident; reckless driving (as defined by state law); excessive speed; any similar violation deemed by Secretary of DOT to be serious. Sanctions: 60 days for 2 violations in 3 years; 120 days for 3 violations in 3 years.



**Health, Safety and Environmental Standard**

|                               |   |   |
|-------------------------------|---|---|
| Effective Date:<br>01/01/2013 | <b>Motor Vehicle Record (MVR)<br/>Review - Regulated Vehicles</b> | Standard Number:<br><b>HSE 4300.030</b> |
| Supersedes:<br>N/A            |   | Page 4 of 10                            |

**6. MOTOR VEHICLE RECORDS (MVR) REVIEW**

A new hire or an existing employee that is promoted or transferred into a job requiring the operation of a vehicle on the Company's behalf will be required to complete a Motor Vehicle Policy and Record Release (Exhibit A), which will be kept on file throughout his/her employment, for all States excluding Pennsylvania and New Hampshire. Pennsylvania and New Hampshire licensed drivers must complete their respective State specific form (Exhibits B and C) in compliance with State requirements.

**6.1 New Hires - Initial Review**

This section applies to applicants being hired into jobs that require the operation of a regulated vehicle. MVR's shall be secured for the preceding three (3) year period from the appropriate agency in every state in which the applicant was licensed to operate a motor vehicle. The inquiry to state agencies must be made as a part of the pre-employment screening process.

**6.2 Employees - Initial Review/Annual Review**

Any time after hiring that an employee, regardless of his/her classification, is being qualified to operate a vehicle which is regulated by State or Federal Motor Carrier Safety Regulations (MCSR) or the Commercial Motor Vehicle Safety Act of 1986, the provisions specified in Section 4.1 above must be complied with. MVR's must be secured annually and/or prior to promotion or transfer into a job requiring the operation of a vehicle covered by state or federal motor carrier safety regulations.

**6.3 Employees - Regular and Periodic Review**

Upon employment, one year after employment as a driver under these rules and annually thereafter, each employee/driver shall prepare and furnish their supervisor with a list of driving violations (exclusive of parking violations) for which they have been convicted or forfeited bond or collateral during the past 12 months. (See Exhibit D, Violation and Review Record.)

Failure by the employee/driver to list violations described above for which he/she has been convicted or to otherwise falsify entries will subject each employee/driver to appropriate disciplinary action up to and including discharge. MVR's shall be secured for any employee/driver listing a "disqualifying" offense or two or more non-disqualifying offenses. Section 4 describes "disqualifying" offenses. "Non-disqualifying" offenses include any other traffic offenses excluding parking violations.

In reviewing the driving record the leader/supervisor in charge must consider any evidence that the driver has violated applicable provisions of the State or Federal Motor Carrier Safety Regulations and/or the Hazardous Materials Regulations. The leader/supervisor must also consider the driver's non-duty accident record and any evidence that the driver has violated laws governing the operation of motor vehicles, and must give great weight to violations, such as speeding, reckless driving, and



**Distribution Operations**

**Health, Safety and Environmental Standard**

|                               |   |   |
|-------------------------------|---|---|
| Effective Date:<br>01/01/2013 | <b>Motor Vehicle Record (MVR)<br/>Review - Regulated Vehicles</b> | Standard Number:<br><b>HSE 4300.030</b> |
| Supersedes:<br>N/A            |   | Page 5 of 10                            |

operating while under the influence of alcohol or drugs, that indicate that the driver has exhibited a disregard for the safety of the public. MVR review must comply with the eligibility guidelines established in the NGD Safe Driver Program.

In addition to MVR's required to be secured under the provisions listed above, MVR's may be secured for employee/drivers of regulated vehicles anytime there is a reasonable doubt as to the employee's accident record or the validity of his/her license.

**7. EMPLOYEE RESPONSIBILITY**

It shall be the responsibility of any employee/driver who receives a notice that his/her license, permit or privilege to operate a motor vehicle has been suspended, revoked, or withdrawn to notify his/her supervisor of the contents of the notice before the end of the business day following the day it is received. Additionally, each new hire or regular driver who operates a vehicle regulated by the Commercial Motor Vehicle Safety Act of 1986 shall complete and sign the Notice To Drivers and Certificate of Compliance (Exhibit E). Exhibit E signed and dated shall be retained for the duration of employment.



Distribution Operations

Health, Safety and Environmental Standard

|                               |   |   |
|-------------------------------|---|---|
| Effective Date:<br>01/01/2013 | <b>Motor Vehicle Record (MVR)<br/>Review - Regulated Vehicles</b> | Standard Number:<br><b>HSE 4300.030</b> |
| Supersedes:<br>N/A            |   | Page 6 of 10                            |

EXHIBIT A



Vehicle Policy

**Motor Vehicle Policy And Record Release**

As an employee of NiSource, I acknowledge my understanding of the NGD Safe Driver Program.

I have a valid driver's license and agree to notify my supervisor immediately upon any suspension, revocation or other loss of driving privileges.

Should I lose my driving privileges, I also understand that I will be prohibited from operating a vehicle on the Company's behalf.

I hereby agree to allow NiSource to access my Motor Vehicle Record throughout the term of my employment for the purpose of assessing my driving performance and providing focused driving training for my enhanced safety.

\_\_\_\_\_  
Employee Name (please print)

\_\_\_\_\_  
Employee ID #

\_\_\_\_\_  
Driver's License Number/Issue State

\_\_\_\_\_  
Signature

\_\_\_\_\_  
Date





Health, Safety and Environmental Standard

|                               |   |   |
|-------------------------------|---|---|
| Effective Date:<br>01/01/2013 | <b>Motor Vehicle Record (MVR)<br/>Review - Regulated Vehicles</b> | Standard Number:<br><b>HSE 4300.030</b> |
| Supersedes:<br>N/A            |   | Page 7 of 10                            |

**EXHIBIT B**

The most current version of this form can be found at [www.dmv.state.pa.us](http://www.dmv.state.pa.us)

DL-503 (7-11)

**REQUEST FOR DRIVER INFORMATION**

The most current version of this form can be found at [www.dmv.state.pa.us](http://www.dmv.state.pa.us)  
PLEASE TYPE OR PRINT IN BLUE OR BLACK INK  
DO NOT SEND CASH • SEE REVERSE FOR INSTRUCTIONS



Bureau of Driver Licensing  
P.O. Box 68926  
Harrisburg, PA 17106-9826

CHECK (✓) ONE ONLY:

- BASIC INFORMATION: \$5.00 FEE (Driver history is not included)
- 3 YEAR DRIVER RECORD: \$5.00 FEE
- 10 YEAR DRIVER RECORD: \$5.00 FEE (Employment Purposes Only)

- FULL HISTORY: \$5.00 FEE
- CERTIFIED DRIVER RECORD: \$10.00 FEE
- COPY OF DOCUMENT FROM FILE (MICROFILM): \$5.00 FEE
- CERTIFIED COPY OF DOCUMENT FROM FILE: \$10.00 FEE

You may obtain a copy of your own 3 year, 10 year and/or Full History Driving Record on PennDOT's website at [www.dmv.state.pa.us](http://www.dmv.state.pa.us)

|   |   |
|---|---|
| <p><b>A REQUESTER INFORMATION</b></p> <p>NAME/COMPANY _____</p> <p>ADDRESS _____</p> <p>CITY _____ STATE _____ ZIP CODE _____</p> <p>DAYTIME TELEPHONE NUMBER (REQUIRED) _____</p> <p>RELATIONSHIP TO DRIVER (REQUIRED) _____</p> <p>SIGNATURE <u>X</u> _____<br/>NOTARIZATION NOT REQUIRED WHEN REQUESTING YOUR OWN RECORD</p> | <p><b>B END USER OF INFORMATION BEING REQUESTED</b></p> <p>NAME/COMPANY _____</p> <p>ADDRESS (P.O. Box not acceptable, need to provide physical location of business/residence) _____</p> <p>CITY _____ STATE _____ ZIP CODE _____</p> <p>DAYTIME TELEPHONE NUMBER (REQUIRED) _____</p> <p>RELATIONSHIP TO DRIVER (REQUIRED) _____</p>  |
| <p><b>C DRIVER INFORMATION</b></p> <p>NAME: LAST _____ FIRST _____ INITIAL _____</p> <p>ADDRESS _____</p> <p>CITY _____</p> <p>STATE _____ ZIP CODE _____</p> <p>PHONE NUMBER _____</p> <p>DATE OF BIRTH: MONTH _____ DAY _____ YEAR _____ DRIVER NUMBER _____</p>  | <p><b>D AFFIDAVIT OF INTENDED USE</b></p> <p>Intended Use of the Information Requested: CHECK ONLY ONE</p> <ul style="list-style-type: none"> <li><input type="checkbox"/> B=Driver Release (Driver must complete Section E.)</li> <li><input type="checkbox"/> C=Credit Business (Legitimate Business need in connection with a business transaction initiated by the driver.)</li> <li><input type="checkbox"/> C=Credit Potential Investor, Server or Current Insurer (In connection with an assessment of the credit/payment risks associated with an existing credit obligation.)</li> <li><input type="checkbox"/> E=Employment (to support the hiring or the continuation of employment. Driver must complete Section E.)</li> <li><input type="checkbox"/> R=Insurance Company requesting record of person it intends to insure, now insures, or has rejected for insurance.</li> <li><input type="checkbox"/> K=Court Order must be attached. (A subpoena issued in compliance with Pa. R.C.P. 4009.21 will be accepted in lieu of a court order).</li> <li><input type="checkbox"/> L=Attorney representing driver identified in Section C (Driver must complete Section E.)</li> </ul> <p>I hereby Certify that _____ PRINTED NAME OF REQUESTER</p> <p>will use the driver record abstract(s) required pursuant to Section 6114 of the Pennsylvania Vehicle Code, for the purpose checked above only and no other reason. This affidavit is filed in compliance with Section 607 of the Fair Credit Reporting Act. I/We have read and signed this form after its completion, and I/We swear or affirm that the statements made herein are true and correct, and that any statement made on or pursuant to this form is subject to the penalties of 18 Pa.C.S. Section 4903(a)(2) (relating to false swearing), which shall include punishment of a fine not exceeding \$5,000, or to a term of imprisonment of not more than two years, or both.</p> <p><u>X</u> _____ SIGNATURE OF REQUESTER</p> <p>Title _____</p> |
| <p><b>E DRIVER RELEASE</b></p> <p>I _____ NAME OF DRIVER _____ hereby request the Department of Transportation to furnish a copy of my PA Driver's Record to _____ NAME OF PERSON/COMPANY _____</p> <p><u>X</u> _____ SIGNATURE OF DRIVER DATE _____</p>  | <p><b>F MICROFILM</b></p> <p>TYPE OF DOCUMENT _____ DATE OF VIOLATION _____</p> <p>(see list of available documents below)</p> <p><b>Documents Available:</b></p> <ul style="list-style-type: none"> <li style="width: 50%;">• Citations</li> <li style="width: 50%;">• Suspension Credit Affidavits</li> <li style="width: 50%;">• Court Certifications</li> <li style="width: 50%;">• Suspension/Revocation Letters</li> <li style="width: 50%;">• Applications</li> <li style="width: 50%;">• Restoration Letters</li> <li style="width: 50%;">• License Renewals</li> <li style="width: 50%;">• Rescind Letters</li> <li style="width: 50%;">• Judgments</li> <li style="width: 50%;">• Department Hearing or Exam Notice</li> </ul> <p>MESSSENGER NO. _____</p>  |
| <p><b>NOTARIZATION</b></p> <p>SUBSCRIBED AND SWORN TO BEFORE ME: MONTH _____ DAY _____ YEAR _____</p> <p><u>X</u> _____ SIGNATURE OF PERSON ADMINISTERING OATH</p> <p><b>S E A L</b></p> <p>SIGN IN PRESENCE OF NOTARY</p>  |   |



|                               |   |   |
|-------------------------------|---|---|
| Effective Date:<br>01/01/2013 | <b>Motor Vehicle Record (MVR)<br/>Review - Regulated Vehicles</b> | Standard Number:<br><b>HSE 4300.030</b> |
| Supersedes:<br>N/A            |   | Page 8 of 10                            |

**EXHIBIT C**

The most current version of this form can be found at [www.nh.gov/safety/divisions/dmv/forms](http://www.nh.gov/safety/divisions/dmv/forms)

**RELEASE OF  
MOTOR VEHICLE  
RECORDS**  
  
(Pursuant to RSA 260:14)



**NH DEPARTMENT OF SAFETY  
Division of Motor Vehicles**  
23 Hazen Drive, Concord, NH 03305  
Tel: Driver Records (603) 271-2322  
Registration (603) 271-2251  
Repro (603) 271-2128  
Title (603) 271-3111  
Fax (603) 271-1051 (all areas)

Form DSMV 505 (Rev. 07/09)

|  |  |
|--|--|
| <p><b>I. Requested Information: Are you requesting:</b></p> <p>A. <input type="checkbox"/> Your Motor Vehicle Record?</p> <p>B. <input type="checkbox"/> Another person's Motor Vehicle Record?<br/><small>The back of this form must be completed and notarized.</small></p> <p>C. <input type="checkbox"/> Another person's Motor Vehicle Record as an authorized agent of your employer or a company?<br/><small>A Certificate of Authority must accompany this request, or one must be on file with the Division of Motor Vehicles.</small></p>  | <p><b>II. Requestor Information:</b></p> <p>Name of Requestor: _____</p> <p>Employer/Company (if applicable): _____</p> <p>Address: _____ Tele #: _____</p> <p>City: _____ State: _____ Zip: _____</p>   |
| <p><b>III. Requested Records:</b></p> <p><input type="checkbox"/> Driver Record (Certified copy): \$15.00</p> <p><input type="checkbox"/> Driver Record (Non-Certified copy): \$15.00</p> <p><input type="checkbox"/> Driver Record (Insurance copy): \$15.00</p> <p><input type="checkbox"/> Registration Listing (Current Information Only): \$ 5.00</p> <p><input type="checkbox"/> Registration (Certified copy): \$15.00</p> <p><input type="checkbox"/> Title Search: \$20.00</p> <p><input type="checkbox"/> License Applications and Letters of Verification: \$15.00</p> <p><input type="checkbox"/> Insurance Card (Accident use only): \$ 1.00</p> <p><input type="checkbox"/> Accident Report (Requestor will be notified of cost): \$ 1.00 per page (\$5.00 minimum)</p> <p><input type="checkbox"/> Other: _____ : \$ _____</p> <p><b>Make checks payable to "State of NH - DMV"</b></p> | <p><b>IV. Intended Use of Information:</b><br/><b><u>IMPORTANT: To be completed only if you checked Box C above</u></b></p> <p><input type="checkbox"/> For use in connection with any civil, criminal, administrative or arbitral proceeding. Docket# _____ Court: _____ [RSA 260:14 V (a)(2)].</p> <p><input type="checkbox"/> By a bank or similar institution to verify the accuracy of personal information submitted by the individual to the bank [RSA 260:14 V (a)(3)].</p> <p><input type="checkbox"/> For providing notice to the owner(s) of a towed or impounded vehicle [RSA 260:14 V (a)(5)].</p> <p><input type="checkbox"/> For use by any private investigative agency or security service licensed by this state for any purpose permitted pursuant to RSA 260:14, V (a), other than for bulk distribution for surveys, marketing or solicitations pursuant to RSA 260:14, V (a)(8) _____ [RSA 260:14 V (a)(6)].<br/><small>Indicate specific reason here</small></p> <p><input type="checkbox"/> By an employer or its agent or insurer to obtain or verify information relating to a holder of a commercial driver's license [RSA 260:14 V (a)(7)].</p> <p><input type="checkbox"/> By a public utility to perform its public service obligation provided the individual has given their express consent [RSA 260:14, V (a)(9)].</p> <p><input type="checkbox"/> For an insurance company or by its authorized agent [RSA 260:14 IV (a)(2)].</p> <p><input type="checkbox"/> Vehicle or boat information only.</p> <p><input type="checkbox"/> For use by a life insurance company authorized to write life insurance policies in New Hampshire, or its authorized agent. In checking off this box, I represent that the named person's written consent to the release of the record has been obtained and that the record will be used solely in connection with claims investigation, rating, and underwriting. _____ [(RSA 260:14, V(a)(10))]<br/><small>(initial here)</small></p> |
| <p><b>V. Search For (provide all applicable information):</b></p> <p>Name: _____</p> <p>Date of Birth: _____</p> <p>Registration/Plate #: _____</p> <p>Driver License/I.D. #: _____</p> <p>Vehicle Identification #: _____</p>   | <p>Last Known Address: _____</p> <p>Date of Accident: _____</p> <p>Location of Accident: _____<br/><small>Route/Street City/Town</small></p> <p>Other Identification Information: _____</p>  |

**\*\*\*Reverse Side Must Be Completed Before Processing\*\*\***



**Health, Safety and Environmental Standard**

|                               |   |   |
|-------------------------------|---|---|
| Effective Date:<br>01/01/2013 | <b>Motor Vehicle Record (MVR)<br/>Review - Regulated Vehicles</b> | Standard Number:<br><b>HSE 4300.030</b> |
| Supersedes:<br>N/A            |   | Page 9 of 10                            |

**EXHIBIT D**

**VIOLATION AND REVIEW RECORD**

Driver's Name \_\_\_\_\_  
Please Print

**I. CERTIFICATION OF VIOLATIONS**

I certify that the following is a true and complete list of traffic violations (other than parking violations) for which I have been convicted or forfeited bond or collateral during the past 12 months.

| Date  | Offense | Location | Type of Vehicle Operated |
|-------|---------|----------|--------------------------|
| _____ | _____   | _____    | _____                    |
| _____ | _____   | _____    | _____                    |
| _____ | _____   | _____    | _____                    |
| _____ | _____   | _____    | _____                    |
| _____ | _____   | _____    | _____                    |

If no violations are listed above, I certify that I have not been convicted or forfeited bond or collateral on account of any violation required to be listed during the past 12 months.

|                                 |                                  |
|---------------------------------|----------------------------------|
| _____<br>Date of Certificate    | _____<br>Driver's Signature      |
| _____<br>Motor Carrier's Name   | _____<br>Motor Carrier's Address |
| _____<br>Reviewed by: Signature | _____<br>Title & Date            |

**II. REVIEW AND EVALUATION OF DRIVER'S RECORD**

In accordance with Section 391.25, Motor Carrier Safety Regulations, all information pertinent to the above driver's safety of operations, including the list of violations furnished by him in accordance with Section 391.27, has been reviewed for the past 12 months.

Action taken: \_\_\_\_\_  
\_\_\_\_\_  
\_\_\_\_\_  
\_\_\_\_\_

|                                 |                                  |
|---------------------------------|----------------------------------|
| _____<br>Motor Carrier's Name   | _____<br>Motor Carrier's Address |
| _____<br>Reviewed by: Signature | _____<br>Title & Date            |



**Health, Safety and Environmental Standard**

|                               |   |   |
|-------------------------------|---|---|
| Effective Date:<br>01/01/2013 | <b>Motor Vehicle Record (MVR)<br/>Review - Regulated Vehicles</b> | Standard Number:<br><b>HSE 4300.030</b> |
| Supersedes:<br>N/A            |   | Page 10 of 10                           |

**EXHIBIT E**

**NOTICE TO DRIVERS  
&  
CERTIFICATE OF COMPLIANCE**

**I. Notice To Drivers**

The Commercial Motor Vehicle Safety Act of 1986 provides for a set of controls over the drivers of commercial vehicles. The law applies to all drivers operating vehicles and combinations with a Gross Vehicle Weight Rating over 26,000 pounds, and to any vehicle, regardless of weight, transporting hazardous materials.

The following provisions of this legislation became effective July 1, 1997:

1. No driver may possess more than one license and no motor carrier may use a driver having more than one license.
2. A driver convicted of a traffic violation (other than parking) must notify the motor carrier, AND the state which issued the license to that driver, of such conviction within 30 days.
3. Any person applying for a job as a commercial vehicle driver must inform the prospective employer of all previous employment as the driver of a commercial vehicle for the past 10 years. In addition to any other required information about the applicant's employment history.
4. Any violation is punishable by a fine not to exceed \$2,500. In addition, the Federal Motor Carrier Safety Regulations now require that a driver who loses any privilege to operate a commercial vehicle, or who is disqualified from operating a commercial vehicle, must advise the motor carrier the next business day after receiving notification of such action.

-----  
**TO BE RETAINED BY MOTOR CARRIER**

**II. Certification By Driver** \_\_\_\_\_  
Company Work Location

I hereby certify that I have read and understand the driver provisions of the Commercial Motor Vehicle Safety Act of 1986.

Driver's Name (print) \_\_\_\_\_ Soc. Sec. # \_\_\_\_\_

Driver's Address \_\_\_\_\_

License: State \_\_\_\_\_ Type/Class \_\_\_\_\_ ID No. \_\_\_\_\_

I further certify that the above commercial vehicle license is the only one held or that I have surrendered the following licenses to the state indicated.

State \_\_\_\_\_ Type/Class \_\_\_\_\_ ID No. \_\_\_\_\_

State \_\_\_\_\_ Type/Class \_\_\_\_\_ ID No. \_\_\_\_\_

Driver's Signature \_\_\_\_\_



## Health, Safety and Environmental Standard

### Distribution Operations

|                               |  |   |
|-------------------------------|--|---|
| Effective Date:<br>01/01/2013 | <b>Motor Vehicle Record (MVR)<br/>Review (Non Regulated Drivers)</b> | Standard Number:<br><b>HSE 4300.032</b> |
| Supersedes:<br>N/A            |  | Page 1 of 6                             |

Companies Affected:

|                                 |   |   |
|---------------------------------|---|---|
| <input type="checkbox"/> NIPSCO | <input checked="" type="checkbox"/> CGV | <input checked="" type="checkbox"/> CMD |
|                                 | <input checked="" type="checkbox"/> CKY | <input checked="" type="checkbox"/> COH |
|                                 | <input checked="" type="checkbox"/> CMA | <input checked="" type="checkbox"/> CPA |

**REFERENCE** [HSE 4300.030](#) "Motor Vehicle Record (MVR) Review - Regulated Vehicles"

### 1. SCOPE

This standard applies NiSource Gas Distribution (NGD)-wide to all current and prospective employees whose operation of a motor vehicle on Company business is not otherwise covered under the Department of Transportation's Federal/State Motor Carrier Safety Regulations and/or the Commercial Motor Vehicle Safety Act of 1986.

### 2. INTRODUCTION

As a public utility the company has a duty to ensure the safety of its employees and the general public while operating vehicles on company business. NiSource Gas Distribution (NGD) believes that the risk and liability surrounding the operation of motor vehicles can be minimized by providing focused driving training and examining the driving records of current and prospective employees. The status of an individual's driving record will be considered when making employment, promotion, and transfer decisions.

### 3. DEFINITIONS

#### 3.1 Serious Violations

Serious Violations are convictions that indicate a disregard for public safety such as the following.

- a. Driving under suspension, cancellation, or revocation of a license.
- b. False collision report/perjury.
- c. Fleeing or eluding police.
- d. Homicide, manslaughter, or assault with a motor vehicle.
- e. Leaving the scene of a collision.
- f. Obstructing an officer.
- g. Reckless driving.
- h. Refusal to comply with a lawful police/fire department order.
- i. Illegal possession of alcohol or drugs.
- j. Illegal activity with a motor vehicle.
- k. Unlawful use or display of a license.

*This document is considered CONTROLLED only when viewed electronically on the Company's intranet. Printed or other electronic copies may not be current, and the intranet version should be used to verify.*



## Health, Safety and Environmental Standard

### Distribution Operations

|                               |  |   |
|-------------------------------|--|---|
| Effective Date:<br>01/01/2013 | <b>Motor Vehicle Record (MVR)<br/>Review (Non Regulated Drivers)</b> | Standard Number:<br><b>HSE 4300.032</b> |
| Supersedes:<br>N/A            |  | Page 2 of 6                             |

- l. Driving under the influence.
- m. Refusal to submit to test for alcohol.
- n. Hit and run.

### 3.2 Major Violations

Major Violations are serious convictions which indicate a disregard for public safety such as the following.

- a. Driving while intoxicated (drugs/alcohol).
- b. Reckless driving where bodily injury or property damage results.
- c. Hit and run.
- d. Negligent homicide.

### 3.3 Capital Violations

Capital Violations include felonies such as the following.

- a. Murder or assault with a motor vehicle.
- b. Theft of a motor vehicle and related offenses.

### 3.4 Moving Violations

Moving Violations include, but are not limited to the following.

- a. Speeding.
- b. Traffic signal or stop-sign infractions.

## 4. POLICY

A new hire or an existing employee that is promoted or transferred into a job requiring the operation of a vehicle on the Company's behalf will be required to complete a Motor Vehicle Policy and Record Release (Exhibit A), which will be kept on file throughout his/her employment, for all States excluding Pennsylvania and New Hampshire. Pennsylvania and New Hampshire licensed drivers must complete their respective State specific form (Exhibits B and C) in compliance with State requirements.

### 4.1 New Hires - Initial Review

The Motor Vehicle Record (MVR) of each prospective employee who may operate a motor vehicle on Company business will be secured and reviewed prior to employment to determine if the individual possesses a valid driver's or operator's license and has, during the preceding three (3) year period, operated a motor vehicle in a safe, responsible manner. The hiring of any employee who has the potential to operate a



**Distribution Operations**

**Health, Safety and Environmental Standard**

|                               |  |   |
|-------------------------------|--|---|
| Effective Date:<br>01/01/2013 | <b>Motor Vehicle Record (MVR)<br/>Review (Non Regulated Drivers)</b> | Standard Number:<br><b>HSE 4300.032</b> |
| Supersedes:<br>N/A            |  | Page 3 of 6                             |

motor vehicle on the Company's behalf should be contingent upon receipt of an acceptable "Low Risk" MVR Report as outlined in the Pre-employment section of the NGD Safe Driver Program.

**4.2 Employees – Promotion/Transfer Review**

The MVR of an employee who is to be promoted or transferred into a position which requires him/her to operate a vehicle on the Company's behalf will be secured and examined prior to the promotion or transfer. Approval of the promotion or transfer may be denied if the MVR check reveals to be "High Risk" as outlined in the NGD Safe Driver Program.

**4.3 Employees - Periodic Review**

MVRs will be annually reviewed on all Leadership and Non-Regulated employees assigned a Company Vehicle, or who have the potential to operate a vehicle on the Company's behalf, as part of their required job function. Based on the results of that review, the employee must complete any required training and/or licensing and meet performance expectations per the guidelines established within the NGD Safe Driver Program.

**5. CONFIDENTIALITY**

It shall be the responsibility of any employee/driver who receives a notice that his/her license, permit or privilege to operate a motor vehicle has been suspended, revoked, or withdrawn to notify his/her supervisor of the contents of the notice before the end of the business day following the day it is received.

Employees' and prospective employees' motor vehicle records shall be maintained in a confidential manner to the extent that is reasonable and practical. Dissemination of MVR and related information will be limited strictly on a need-to-know basis.



Distribution Operations

Health, Safety and Environmental Standard

|                               |  |   |
|-------------------------------|--|---|
| Effective Date:<br>01/01/2013 | <b>Motor Vehicle Record (MVR)<br/>Review (Non Regulated Drivers)</b> | Standard Number:<br><b>HSE 4300.032</b> |
| Supersedes:<br>N/A            |  | Page 4 of 6                             |

EXHIBIT A



Vehicle Policy

**Motor Vehicle Policy And Record Release**

As an employee of NiSource, I acknowledge my understanding of the NGD Safe Driver Program.

I have a valid driver's license and agree to notify my supervisor immediately upon any suspension, revocation or other loss of driving privileges.

Should I lose my driving privileges, I also understand that I will be prohibited from operating a vehicle on the Company's behalf.

I hereby agree to allow NiSource to access my Motor Vehicle Record throughout the term of my employment for the purpose of assessing my driving performance and providing focused driving training for my enhanced safety.

\_\_\_\_\_  
Employee Name (please print)

\_\_\_\_\_  
Employee ID #

\_\_\_\_\_  
Driver's License Number/Issue State

\_\_\_\_\_  
Signature

\_\_\_\_\_  
Date





Health, Safety and Environmental Standard

|                               |  |   |
|-------------------------------|--|---|
| Effective Date:<br>01/01/2013 | <b>Motor Vehicle Record (MVR)<br/>Review (Non Regulated Drivers)</b> | Standard Number:<br><b>HSE 4300.032</b> |
| Supersedes:<br>N/A            |  | Page 5 of 6                             |

**EXHIBIT B**

The most current version of this form can be found at [www.dmv.state.pa.us](http://www.dmv.state.pa.us)

DL-503 (7-11)

**REQUEST FOR DRIVER INFORMATION**

The most current version of this form can be found at [www.dmv.state.pa.us](http://www.dmv.state.pa.us)  
PLEASE TYPE OR PRINT IN BLUE OR BLACK INK  
DO NOT SEND CASH • SEE REVERSE FOR INSTRUCTIONS



Bureau of Driver Licensing  
P.O. Box 68905  
Harrisburg, PA 17106-9005

CHECK (✓) ONE ONLY:

- BASIC INFORMATION: \$5.00 FEE (Driver history is not included)
- 3 YEAR DRIVER RECORD: \$5.00 FEE
- 10 YEAR DRIVER RECORD: \$5.00 FEE (Employment Purposes Only)

- FULL HISTORY: \$5.00 FEE
- CERTIFIED DRIVER RECORD: \$10.00 FEE
- COPY OF DOCUMENT FROM FILE (MICROFILM): \$5.00 FEE
- CERTIFIED COPY OF DOCUMENT FROM FILE: \$10.00 FEE

You may obtain a copy of your own 3 year, 10 year and/or Full History Driving Record on PennDOT's website at [www.dmv.state.pa.us](http://www.dmv.state.pa.us)

|   |  |
|---|--|
| <p><b>A REQUESTER INFORMATION</b></p> <p>NAME/COMPANY _____</p> <p>ADDRESS _____</p> <p>CITY _____ STATE _____ ZIP CODE _____</p> <p>DAYTIME TELEPHONE NUMBER (REQUIRED) _____</p> <p>RELATIONSHIP TO DRIVER (REQUIRED) _____</p> <p>SIGNATURE <u>X</u> _____</p> <p>NOTARIZATION NOT REQUIRED WHEN REQUESTING YOUR OWN RECORD</p> <p><b>C DRIVER INFORMATION</b></p> <p>NAME: LAST _____ FIRST _____ INITIAL _____</p> <p>ADDRESS _____</p> <p>CITY _____</p> <p>STATE _____ ZIP CODE _____</p> <p>PHONE NUMBER _____</p> <p>DATE OF BIRTH _____ DRIVER NUMBER _____</p> <p>MONTH _____ DAY _____ YEAR _____</p> <p><b>E DRIVER RELEASE</b></p> <p>I _____ hereby request<br/>the Department of Transportation to furnish a copy of my PA Driver's<br/>Record to _____</p> <p>NAME OF DRIVER _____<br/>NAME OF PERSON/COMPANY _____</p> <p><u>X</u> _____<br/>SIGNATURE OF DRIVER DATE _____</p> <p><b>F MICROFILM</b></p> <p>TYPE OF DOCUMENT _____ DATE OF VIOLATION _____</p> <p>(see list of available documents below)</p> <p><b>Documents Available:</b></p> <ul style="list-style-type: none"> <li style="width: 50%;">• Citations</li> <li style="width: 50%;">• Suspension Credit Affidavits</li> <li style="width: 50%;">• Court Certifications</li> <li style="width: 50%;">• Suspension/Revocation Letters</li> <li style="width: 50%;">• Applications</li> <li style="width: 50%;">• Restoration Letters</li> <li style="width: 50%;">• License Renewals</li> <li style="width: 50%;">• Rescind Letters</li> <li style="width: 50%;">• Judgments</li> <li style="width: 50%;">• Department Hearing or Exam Notice</li> </ul> <p>MESSANGER NO. _____</p> | <p><b>B END USER OF INFORMATION BEING REQUESTED</b></p> <p>NAME/COMPANY _____</p> <p>ADDRESS (P.O. Box not acceptable), need to provide physical location of business/residence _____</p> <p>CITY _____ STATE _____ ZIP CODE _____</p> <p>DAYTIME TELEPHONE NUMBER (REQUIRED) _____</p> <p>RELATIONSHIP TO DRIVER (REQUIRED) _____</p> <p><b>D AFFIDAVIT OF INTENDED USE</b></p> <p>Intended Use of the Information Requested: CHECK ONLY ONE</p> <ul style="list-style-type: none"> <li><input type="checkbox"/> B = Driver Release (Driver must complete Section E.)</li> <li><input type="checkbox"/> C = Credit Business (Legitimate Business need in connection with a business transaction initiated by the driver.)</li> <li><input type="checkbox"/> C = Credit Potential Investor, Server or Current Insurer (In connection with an assessment of the credit/payment risks associated with an existing credit obligation.)</li> <li><input type="checkbox"/> E = Employment (To support the hiring or the continuation of employment. Driver must complete Section E.)</li> <li><input type="checkbox"/> R = Insurance Company requesting record of person it intends to insure, now insures, or has rejected for insurance.</li> <li><input type="checkbox"/> K = Court Order must be attached. (A subpoena issued in compliance with Pa. R.C.P. 4009.21 will be accepted in lieu of a court order).</li> <li><input type="checkbox"/> L = Attorney representing driver identified in Section C (Driver must complete Section E.)</li> </ul> <p>I hereby Certify that _____ PRINTED NAME OF REQUESTER</p> <p>will use the driver record abstract(s) required pursuant to Section 6114 of the Pennsylvania Vehicle Code, for the purpose checked above only and no other reason. This affidavit is filed in compliance with Section 607 of the Fair Credit Reporting Act. I/We have read and signed this form after its completion, and I/We swear or affirm that the statements made herein are true and correct, and that any statement made on or pursuant to this form is subject to the penalties of 18 Pa.C.S. Section 4903(a)(2) (relating to false swearing), which shall include punishment of a fine not exceeding \$5,000, or to a term of imprisonment of not more than two years, or both.</p> <p><u>X</u> _____<br/>SIGNATURE OF REQUESTER</p> <p>Title _____</p> <p>SUBSCRIBED AND SWORN<br/>TO BEFORE ME: MONTH _____ DAY _____ YEAR _____</p> <p><u>X</u> _____<br/>SIGNATURE OF PERSON ADMINISTERING OATH</p> <p style="text-align: center;">SIGN IN PRESENCE OF NOTARY</p> |
|---|--|

NOTARIZATION

S  
E  
A  
L





Distribution Operations

Health, Safety and Environmental Standard

|                               |  |   |
|-------------------------------|--|---|
| Effective Date:<br>01/01/2013 | <b>Motor Vehicle Record (MVR)<br/>Review (Non Regulated Drivers)</b> | Standard Number:<br><b>HSE 4300.032</b> |
| Supersedes:<br>N/A            |  | Page 6 of 6                             |

**EXHIBIT C**

The most current version of this form can be found at [www.nh.gov/safety/divisions/dmv/forms](http://www.nh.gov/safety/divisions/dmv/forms)

**RELEASE OF  
MOTOR VEHICLE  
RECORDS**

(Pursuant to RSA 260:14)



**NH DEPARTMENT OF SAFETY  
Division of Motor Vehicles**

23 Hazen Drive, Concord, NH 03305  
Tel: Driver Records (603) 271-2322  
Registration (603) 271-2251  
Repro (603) 271-2128  
Title (603) 271-3111  
Fax (603) 271-1051 (all areas)

Form DSMV 505 (Rev. 07/09)

|  |   |
|--|---|
| <p><b>I. Requested Information: Are you requesting:</b></p> <p>A. <input type="checkbox"/> Your Motor Vehicle Record?</p> <p>B. <input type="checkbox"/> Another person's Motor Vehicle Record?<br/><small>The back of this form must be completed and notarized.</small></p> <p>C. <input type="checkbox"/> Another person's Motor Vehicle Record as an authorized agent of your employer or a company?<br/><small>A Certificate of Authority must accompany this request, or one must be on file with the Division of Motor Vehicles.</small></p>  | <p><b>II. Requestor Information:</b></p> <p>Name of Requestor: _____</p> <p>Employer/Company (if applicable): _____</p> <p>Address: _____ Tele.#: _____</p> <p>City: _____ State: _____ Zip: _____</p>  |
| <p><b>III. Requested Records:</b></p> <p><input type="checkbox"/> Driver Record (Certified copy): \$15.00</p> <p><input type="checkbox"/> Driver Record (Non-Certified copy): \$15.00</p> <p><input type="checkbox"/> Driver Record (Insurance copy): \$15.00</p> <p><input type="checkbox"/> Registration Listing (Current Information Only): \$ 5.00</p> <p><input type="checkbox"/> Registration (Certified copy): \$15.00</p> <p><input type="checkbox"/> Title Search: \$20.00</p> <p><input type="checkbox"/> License Applications and Letters of Verification: \$15.00</p> <p><input type="checkbox"/> Insurance Card (Accident use only): \$ 1.00</p> <p><input type="checkbox"/> Accident Report (Requestor will be notified of cost): \$ 1.00 per page (\$5.00 minimum)</p> <p><input type="checkbox"/> Other: _____ : \$ _____</p> <p><b>Make checks payable to "State of NH - DMV"</b></p> | <p><b>IV. Intended Use of Information:</b></p> <p><b><u>IMPORTANT: To be completed only if you checked Box C above</u></b></p> <p><input type="checkbox"/> For use in connection with any civil, criminal, administrative or arbitral proceeding. Docket# _____ Court: _____ [RSA 260:14 V (a)(2)].</p> <p><input type="checkbox"/> By a bank or similar institution to verify the accuracy of personal information submitted by the individual to the bank [RSA 260:14 V (a)(3)].</p> <p><input type="checkbox"/> For providing notice to the owner(s) of a towed or impounded vehicle [RSA 260:14 V (a)(5)].</p> <p><input type="checkbox"/> For use by any private investigative agency or security service licensed by this state for any purpose permitted pursuant to RSA 260:14, V (a ), other than for bulk distribution for surveys, marketing or solicitation _____ [RSA 260:14, V (a)(8)]<br/><small>Indicate specific reason here</small></p> <p><input type="checkbox"/> By an employer or its agent or insurer to obtain or verify information relating to a holder of a commercial driver's license [RSA 260:14 V (a)(7)].</p> <p><input type="checkbox"/> By a public utility to perform its public service obligation provided the individual has given their express consent [RSA 260:14, V (a)(9)].</p> <p><input type="checkbox"/> For an insurance company or by its authorized agent [RSA 260:14 IV (a)(2)].</p> <p><input type="checkbox"/> Vehicle or boat information only.</p> <p><input type="checkbox"/> For use by a life insurance company authorized to write life insurance policies in New Hampshire, or its authorized agent. In checking off this box, I represent that the named person's written consent to the release of the record has been obtained and that the record will be used solely in connection with claims investigation, rating, and underwriting. _____ [(RSA 260:14, V(a)(10)]<br/><small>(Initial here)</small></p> |
| <p><b>V. Search For (provide all applicable information):</b></p> <p>Name: _____</p> <p>Date of Birth: _____</p> <p>Registration/Plate #: _____</p> <p>Driver License/I.D. #: _____</p> <p>Vehicle Identification #: _____</p>   | <p>Last Known Address: _____</p> <p>Date of Accident: _____</p> <p>Location of Accident: _____<br/><small>Route/Street City/Town</small></p> <p>Other Identification Information: _____</p>   |

**\*\*\*Reverse Side Must Be Completed Before Processing\*\*\***



Distribution Operations

Health, Safety and Environmental Standard

|                               |                                      |   |
|-------------------------------|--------------------------------------|---|
| Effective Date:<br>01/01/2013 | <b>Commercial Driver's Licensing</b> | Standard Number:<br><b>HSE 4300.035</b> |
| Supersedes:<br>04/01/2011     |                                      | Page 1 of 4                             |

Companies Affected:

|                                 |   |   |
|---------------------------------|---|---|
| <input type="checkbox"/> NIPSCO | <input checked="" type="checkbox"/> CGV | <input checked="" type="checkbox"/> CMD |
|                                 | <input checked="" type="checkbox"/> CKY | <input checked="" type="checkbox"/> COH |
|                                 | <input checked="" type="checkbox"/> CMA | <input checked="" type="checkbox"/> CPA |

**REFERENCE:** Code of Federal Regulations - Title 49 - Part 383 Americans with Disability Act of 1990 Ohio Revised Code, Chapters 4506, 4507, 4921 and 4923 Kentucky Revised Statutes, Sections 281.600 and 281.726 Pennsylvania Consolidated Statutes, Title 75, Sections 1503(a)(4), 1504(c), 1504(d) and 1518; and Title 67, Chapters 231 and 403 Maryland Annotated Code, Title 16, Sections 16-104, 16-110.1, and 25-111(f) and (h) Virginia Corporation Commission Rule 16, Massachusetts General Law Chapter 90F.

**1. COMMERCIAL MOTOR VEHICLE - GENERAL**

**1.1 Federal (Interstate)**

Vehicles and combination vehicles that have a Gross Vehicle or Combination Gross Vehicle Weight Rating above 10,000 lbs. and vehicles, regardless of (GVWR), that transport hazardous materials which must be marked or placarded according to Section 177.823 of Title 49 are covered by the Federal MCSR.

**1.2 States (Intrastate)**

Drivers of Vehicles and combination vehicles that have a Gross Vehicle or Combination Gross Vehicle Weight Rating which exceed the following weight thresholds are subject to intrastate Motor Carrier Safety Regulations.

Ohio - Above 26,000 lbs.

Virginia - Above 26,000 lbs.

Kentucky - Above 10,000 lbs.

Maryland - Above 10,000 lbs.

Pennsylvania - Above 10,000 lbs.

Massachusetts - Above 10,000 lbs.

The provisions of the following standards are applicable to drivers required to have a CDL.

*This document is considered CONTROLLED only when viewed electronically on the Company's intranet. Printed or other electronic copies may not be current, and the intranet version should be used to verify.*



**Distribution Operations**

**Health, Safety and Environmental Standard**

|                               |                                      |   |
|-------------------------------|--------------------------------------|---|
| Effective Date:<br>01/01/2013 | <b>Commercial Driver's Licensing</b> | Standard Number:<br><b>HSE 4300.035</b> |
| Supersedes:<br>04/01/2011     |                                      | Page 2 of 4                             |

| <u>Standard</u>              | <u>Title</u>  |
|------------------------------|---|
| <a href="#">HSE 4300.010</a> | Driver Qualification                                      |
| <a href="#">HSE 4300.030</a> | Motor Vehicle Record (MVR) Review - Regulated Vehicles    |
| <a href="#">HSE 4300.032</a> | Motor Vehicle Record (MVR) Review (Non-Regulated Drivers) |

**2. JOBS REQUIRING CDL'S**

It is not possible to provide a listing of every job throughout NGD that would require a CDL. All positions requiring the driving of a Commercial Motor Vehicle (CMV) as outlined in Section 1, must secure a CDL. Each Business Unit, based upon its own operating conditions, will have to set parameters to assure an adequate number of licensed drivers are available. The following is provided as a guideline as to what should be taken into consideration.

- a. All employees required to operate a CMV shall secure a valid CDL.
- b. In the smaller operating areas, consideration should be given to requiring a CDL for all plant and/or service employees. These are those areas where, out of necessity, employees perform any and all jobs.

**3. RECOMMENDATIONS FOR PERSONS ENTERING POSITIONS REQUIRING CDL'S**

**3.1 New Hires**

New hires entering positions requiring CDL's will be required to obtain a CDL before becoming a regular employee at the end of their probation period or six months, whichever is shorter (unless preempted by a collective bargaining agreement). Any employee failing to obtain a CDL in this period of time will be terminated.

If the work force composition and/or the position being filled immediately requires a CDL driver, then a CDL will be a prerequisite of the job award.

An applicant who is unable to obtain a CDL because of a disability, and is able to perform the other essential functions of a job in construction and maintenance, will be accommodated to the extent that such accommodation does not impose an undue hardship upon the operation. This accommodation will apply only to the extent that the specific position is not assigned a vehicle requiring a CDL and other licensed employees are available in the work location in sufficient numbers to meet the needs of the operating area.



## Health, Safety and Environmental Standard

|                               |                                      |   |
|-------------------------------|--------------------------------------|---|
| Effective Date:<br>01/01/2013 | <b>Commercial Driver's Licensing</b> | Standard Number:<br><b>HSE 4300.035</b> |
| Supersedes:<br>04/01/2011     |                                      | Page 3 of 4                             |

### 3.2 Employees Bidding from Other Jobs

- a. Upon job award, employees will be required to pass the written CDL test and acquire a learner's permit within 30 calendar days or return to their prior position (unless preempted by a collective bargaining agreement). Training material for the written CDL test will be made available to them for self-study purposes.
- b. Failure to secure a CDL within six months will result in the employee being placed in a non-CDL driving position, if available, or terminated from employment (unless preempted by a collective bargaining agreement).

If the work force composition and/or the position being filled immediately requires a CDL driver, then a CDL will be a prerequisite of the job award.

An employee who bids on a non-driving position in construction and maintenance and does not have, or cannot obtain by reason of a disability or otherwise, a CDL and can perform the other essential functions of the job will be accommodated to the extent that such accommodation does not impose an undue hardship upon the operation. The accommodation will apply only to the extent that other CDL licensed employees are available in the work location in sufficient number to meet the needs of the operating area.

Employees will be allowed to use a Company vehicle on the job to practice driving, attend CDL Training, and take the Skills Test. A qualified, experienced driver will be provided to accompany and coach them during the on-the-job practice sessions and as needed for the test.

**NOTE:** All employees desiring to transfer to the construction and maintenance work force will be encouraged to acquire a CDL prior to bidding on the job. The Company will make available the use of training material for self-study and the CDL Training Program may be offered. A Company truck will be made available for the test with the Leader/Supervisor's permission after the Leader/Supervisor has been assured the employee can safely handle the vehicle.

### 4. FEES

The Company will reimburse employees for the following costs in obtaining or attempting to obtain a CDL.

- a. The first learner's permit fee, when required.
- b. The first Skills Test fee, when required.
- c. Upon submission of proof, the difference between the normal driver's license fee and the new or renewal CDL fee.

The Company encourages any employee to obtain and/or retain a CDL regardless of the



**Distribution Operations**

**Health, Safety and Environmental Standard**

|                               |                                      |   |
|-------------------------------|--------------------------------------|---|
| Effective Date:<br>01/01/2013 | <b>Commercial Driver's Licensing</b> | Standard Number:<br><b>HSE 4300.035</b> |
| Supersedes:<br>04/01/2011     |                                      | Page 4 of 4                             |

employee's department or job position. This would apply to both supervisory and non-supervisory employees. The Company will, therefore, reimburse the fees for any employee regardless of whether the current position requires a CDL.

**5. OTHER**

Employee application forms and promotion procedures should be reviewed in light of DOT Commercial Motor Vehicle (CMV) driver requirements and state CDL requirements.

Unless preempted by a collective bargaining agreement, drivers whose CDL is suspended or revoked will be treated as follows.

- a. If an employee is able to perform the other essential functions of a job, they may be accommodated to the extent that such accommodation does not impose an undue hardship upon the operation; i.e., other CDL licensed employees in adequate number are available to meet the needs of the operating area.
- b. If the employee cannot be accommodated, they will be suspended or terminated unless the employee can be placed in a non-driving position, if available.



**Health, Safety and Environmental Standard**

**Distribution Operations**

|                               |  |   |
|-------------------------------|--|---|
| Effective Date:<br>01/01/1999 | <b>Environmental Compliance Policy<br/>Statement</b> | Standard Number:<br><b>HSE 4400.010(KY)</b><br>P&P 580(32-34) |
| Supersedes:<br>N/A            |  | Page 1 of 2   |

Companies Affected:

|                                     |   |                              |
|-------------------------------------|---|------------------------------|
| <input type="checkbox"/> NIPSCO     | <input type="checkbox"/> CGV            | <input type="checkbox"/> CMD |
| <input type="checkbox"/> NIFL       | <input checked="" type="checkbox"/> CKY | <input type="checkbox"/> COH |
| <input type="checkbox"/> Kokomo Gas | <input type="checkbox"/> CMA            | <input type="checkbox"/> CPA |

**REFERENCE** System Environmental Policy Statement, Adopted December 20, 1995, 40 CFR and State analogs

|  |   |
|--|---|
| APPROVED<br><br><b>Robert C. Skaggs</b><br>President and Chief Executive Officer | APPROVED<br><br><b>Andrew J. Sonderman</b><br>Secretary and General Counsel     |
| APPROVED<br><br><b>Joseph W. Kelly</b><br>Vice President - Operations            | APPROVED<br><br><b>Reginald L. Carter</b><br>Senior Vice President - Operations |
| APPROVED<br><br><b>Richard A. Newbold</b><br>Vice President, Southern Region     | APPROVED<br><br><b>Jerry A. Tischer</b><br>Vice President, Northern Region      |

FORM C-1748 PC (8-01)

**1. PLANS STATEMENT OF COMMITMENT**

We are committed to compliance with all applicable federal, state and local environmental statutes, rules and regulations, and to the communication of those requirements as they apply to our organization to our employees.

We reaffirm the long-standing commitment to take all reasonable measures to prevent or mitigate adverse environmental impact from all business activities, giving full regard to evolving industry practices, regulatory requirements, and societal standards of care.

We are committed to promoting environmental awareness and responsibility through training and other educational programs for employees and management.

*This document is considered CONTROLLED only when viewed electronically on the Company's intranet. Printed or other electronic copies may not be current, and the intranet version should be used to verify.*



**Distribution Operations**

**Health, Safety and Environmental Standard**

|                               |  |   |
|-------------------------------|--|---|
| Effective Date:<br>01/01/1999 | <b>Environmental Compliance Policy<br/>Statement</b> | Standard Number:<br><b>HSE 4400.010(KY)</b><br>P&P 580(32-34) |
| Supersedes:<br>N/A            |  | Page 2 of 2   |

We are committed to pro-active environmental compliance assessment of the operations of our company for the purpose of identification, correction and prevention of non-compliance.

We are committed to supporting scientifically sound changes in the environmental regulatory area and changes which enhance our ability to implement innovative solutions to environmental problems.

As a subsidiary of the Columbia Energy Group, we reaffirm our commitment to and adherence to the environmental requirements and principles set out as System policy, as adopted by the Columbia Gas System Board of Directors on December 20, 1995.

**2. RESPONSIBILITY FOR COMPLIANCE**

Every manager and technical or field employee with responsibility and authority for either operating a facility or directing an activity is responsible 1) for ensuring that this corporate environmental compliance policy is applied to that facility or activity and 2) for assuring effective programs for environmental protection are adopted, implemented and maintained.

Shared Services will provide state companies with professional advice and counsel on applicable environmental requirements and will assist in identification and development of programs and projects to ensure environmental obligations are met by the companies.

**3. EMPLOYEE PERFORMANCE**

Environmental Compliance is the responsibility of each and every employee within our organization. As such, we are committed to recognizing all employees contributing to environmental compliance and to enforcing our commitment, as necessary, with discipline pursuant to the companies' progressive discipline policy for violations of company environmental requirements.



**Health, Safety and Environmental Standard**

**Distribution Operations**

|                               |   |  |
|-------------------------------|---|--|
| Effective Date:<br>08/29/1995 | <b>Environmental Occurrence Reporting</b> | Standard Number:<br><b>HSE 4400.020(CG)</b><br>P&P 580-5 |
| Supersedes:<br>N/A            |   | Page 1 of 3  |

Companies Affected:

|                                     |   |   |
|-------------------------------------|---|---|
| <input type="checkbox"/> NIPSCO     | <input checked="" type="checkbox"/> CGV | <input checked="" type="checkbox"/> CMD |
| <input type="checkbox"/> NIFL       | <input checked="" type="checkbox"/> CKY | <input checked="" type="checkbox"/> COH |
| <input type="checkbox"/> Kokomo Gas | <input type="checkbox"/> CMA            | <input checked="" type="checkbox"/> CPA |

**REFERENCE**    None

**1. POLICY STATEMENT**

An environmental occurrence is considered by CDC's Management to be a matter that deserves immediate attention and reporting, regardless of how insignificant the occurrence may appear.

**2. GENERAL**

An environmental occurrence is any release, spill, waste overflow, improper disposal or discovery of a substance that may be considered to contaminate the environment and that may potentially involve CDC. A written or oral allegation is also considered to be an occurrence, regardless of whether substantiated. Examples of environmental occurrences are oil or other liquid spills (regardless of PCB contamination), mercury spills, leaking storage tanks, waste water treatment plant failure, etc.

**3. NOTIFICATION**

Notification to the General Office of an environmental occurrence shall not be delayed. If there is any doubt or question whether the environmental occurrence is reportable, the occurrence shall be reported.

The District shall establish an internal method to handle the notification, both during and after normal working hours.

*This document is considered CONTROLLED only when viewed electronically on the Company's intranet. Printed or other electronic copies may not be current, and the intranet version should be used to verify.*





**Distribution Operations**

**Health, Safety and Environmental Standard**

|                               |   |  |
|-------------------------------|---|--|
| Effective Date:<br>08/29/1995 | <b>Environmental Occurrence Reporting</b> | Standard Number:<br><b>HSE 4400.020(CG)</b><br>P&P 580-5 |
| Supersedes:<br>N/A            |   | Page 2 of 3  |

The District shall telephonically notify in preferential order the following General Office Environmental, Health and Safety Department personnel:

Manager, Environmental Affairs  
Environmental Consultants, Environmental Affairs Section

The General Office contact person will notify as appropriate:

CDC Management  
Environmental Affairs Department - Wilmington  
Law Department  
Communications and Consumer Affairs Department  
Accounting, Tax, and Risk Management Department - Risk Management Section

Notification of the appropriate environmental protection agency and Company insurance carrier will be accomplished by the Law Department and Risk Management Section respectively. Prompt notification is necessary because:

- a. Various Federal and State laws and regulations may require prompt notification and failure to do so could subject the Company to substantial fines.
- b. The Company has insurance to recover losses resulting from environmental related occurrences; however, the carrier(s) must also receive timely notification in order that the Company may be assured coverage.

**4. EMPLOYEE CONDUCT, MEDIA INQUIRY**

The guidance provided in [GS 1150.012\(CG\)](#), [GS 1150.012\(MD\)](#), [GS 1150.012\(PA\)](#), or [GS 1150.012\(VA\)](#) "Guide for Responding to Accidents/Incidents" is applicable to employee conduct and media inquiries for an environmental occurrence.

**5. DOCUMENTATION**

In addition to the telephone notification, District personnel reporting an incident will use Form C 1540, "Preliminary Report," Exhibit A, to assemble information. The guidance provided in the Company's Emergency Manual for use and disposition of Form C 1540 is applicable.

When communicating information in the preparation of the Preliminary Report, report facts, don't guess. Even though initial information may be sketchy, or incomplete, Preliminary Reports are to be made.



Health, Safety and Environmental Standard

|                               |   |  |
|-------------------------------|---|--|
| Effective Date:<br>08/29/1995 | <b>Environmental Occurrence Reporting</b> | Standard Number:<br><b>HSE 4400.020(CG)</b><br>P&P 580-5 |
| Supersedes:<br>N/A            |   | Page 3 of 3  |

EXHIBIT A

FORM C 1548 CPS (REV. 2-95) COLUMBIA GAS DISTRIBUTION COMPANIES  
**PRELIMINARY REPORT**  
of  
Asphyxiations, Explosions, Fires, Major Outages, etc. as outlined in the Emergency Manual

|                                      |                                    |  |      |              |              |
|--------------------------------------|------------------------------------|--|------|--------------|--------------|
| DATE OF OCCURRENCE                   | TIME OF OCCURRENCE<br>A.M.<br>P.M. | NOTIFIED BY (CUSTOMER, FIRE DEPT., POLICE DEPT.): INCLUDE NAME OF INDIVIDUAL REPORTING |      |              |              |
| REPORTED TO (INCLUDE NAME AND TITLE) |                                    | DATE   | TIME | A.M.<br>P.M. |              |
| REPORTED BY (FIELD SUPERVISOR)       |                                    | REPORTED TO (GENERAL OFFICE)   | DATE | TIME         | A.M.<br>P.M. |

LOCATION OF OCCURRENCE  
-----  
-----

LOCATION OF CONTACT SITE (SERVICE CENTER, OFFICE, ETC.) PHONE NUMBER

SUBJECT (EXPLANATION OF WHAT HAPPENED)  
-----  
-----  
-----  
-----  
-----

CAUSE (IF DIG-IN, WAS LINE PROPERLY LOCATED?)  
-----  
-----

WHAT HAS BEEN DONE AND ESTIMATED TIME FOR RESTORING SERVICE  
-----  
-----  
-----

EXTENT OF DAMAGE (PROPERTY)  
-----  
-----

EXTENT OF INJURY (PERSONAL)  
-----  
-----

|  |  |  |
|--|--|--|
| IS THIS DOT REPORTABLE?<br>YES NO                        | IS THIS STATE COMMISSION REPORTABLE?<br>YES NO COURTESY ONLY | IF REPORTABLE, SHOULD DRUG/ALCOHOL TESTING BE PERFORMED?<br>YES NO |
| CLAIMS DEPT. NOTIFIED (NAME)                             | NOTIFIED BY  | DATE TIME A.M. P.M.  |
| GAS CONTROL NOTIFIED (NAME) (LINE BREAKS, OUTAGES, ETC.) | NOTIFIED BY  | DATE TIME A.M. P.M.  |
| LAW DEPT. (NAME)   | NOTIFIED BY  | DATE TIME A.M. P.M.  |
| PUBLIC RELATIONS (NAME)                                  | NOTIFIED BY  | DATE TIME A.M. P.M.  |
| COMMISSION NOTIFIED (NAME)                               | NOTIFIED BY  | DATE TIME A.M. P.M.  |
| OTHERS NOTIFIED (NAME)                                   | NOTIFIED BY  | DATE TIME A.M. P.M.  |



## Health, Safety and Environmental Standard

### Distribution Operations

|                               |   |   |
|-------------------------------|---|---|
| Effective Date:<br>02/07/1996 | <b>Retention of Environmental Documents</b> | Standard Number:<br><b>HSE 4400.030(CG)</b><br>P&P 580-10 |
| Supersedes:<br>N/A            |   | Page 1 of 7   |

Companies Affected:

|                                     |   |   |
|-------------------------------------|---|---|
| <input type="checkbox"/> NIPSCO     | <input checked="" type="checkbox"/> CGV | <input checked="" type="checkbox"/> CMD |
| <input type="checkbox"/> NIFL       | <input checked="" type="checkbox"/> CKY | <input checked="" type="checkbox"/> COH |
| <input type="checkbox"/> Kokomo Gas | <input type="checkbox"/> CMA            | <input checked="" type="checkbox"/> CPA |

**REFERENCE** Code of Federal Regulations - Title 40  
Columbia Gas System Management Program Manual  
Related Kentucky, Maryland, Ohio, Pennsylvania and Virginia  
statutory/regulatory provisions.

### 1. SCOPE

This procedure provides guidelines for identifying various types of environmental activities within a given CDC area for which minimum environmental document retention requirements may apply, and for communicating that information to those with responsibility for compliance so that necessary action can be taken. Since activities at a given CDC facility can vary, the legal environmental document retention requirements for those activities may be different from similar activities at other CDC facilities. The environmental document retention requirements for those activities may change over time.

### 2. DEFINITIONS

Except as otherwise provided for herein, for the purposes of this procedure, certain terms shall be defined as follows:

**"Environmental Document"** means any document which is required to be maintained by law and relates to air, water, waste, USTs, PCBs and Community Right To Know.

**"Facility"** means anything owned, occupied and/or operated by CDC.

**"By law"** refers to applicable federal, state and local laws, rules and regulations.

**"Air"** describes those issues arising under the federal Clean Air Act, as amended, as applicable to facilities and equipment owned and operated by the distribution companies, and associated federal and state regulations.

**"Water"** describes those issues arising under the federal Clean Water Act and related state provisions, including National Pollution Discharge Elimination System (NPDES) permits and Section 404 permits relating to wetlands construction, as well as issues arising under the Safe Drinking Water Act relating to drinking water standards.

*This document is considered CONTROLLED only when viewed electronically on the Company's intranet. Printed or other electronic copies may not be current, and the intranet version should be used to verify.*



**Distribution Operations**

**Health, Safety and Environmental Standard**

|                               |  |   |
|-------------------------------|--|---|
| Effective Date:<br>02/07/1996 | <h2 style="margin: 0;">Retention of Environmental Documents</h2> | Standard Number:<br><b>HSE 4400.030(CG)</b><br>P&P 580-10 |
| Supersedes:<br>N/A            |  | Page 2 of 7   |

**"Waste"** describes those issues arising under the federal Resource Conservation and Recovery Act (RCRA) and state laws which address requirements for the generation, transportation, treatment, storage, and disposal of hazardous waste, including land disposal restrictions.

**"PCB"** describes those issues arising under RCRA and the federal Toxic Substances Control Act relating to the handling and disposal of polychlorinated biphenyls.

**"UST"** issues are those arising under RCRA and state law and relate to leak prevention, leak detection, financial responsibility and corrective action for underground storage tanks.

**"Community Right to Know"** issues arise under the Emergency Planning and Community Right to Know Act and relate to emergency response planning, chemical inventories, and accidental release reporting.

**"Enforcement Action"** means any civil, criminal or administrative proceeding initiated as the result of an alleged violation of any environmental law, rule or regulation by any company subject to this policy and procedure.

**3. METHODOLOGY FOR DETERMINING DOCUMENTS TO BE RETAINED**

For the purposes of this section, a reference to the Environmental Affairs Section refers to either a representative of the Environmental, Health and Safety Department's Environmental Affairs Section or a District Environmental Compliance Administrator, or both.

- a. The Environmental Affairs Section shall contact each Area Manager to assist in making an initial determination of which document retention requirements apply to the various facilities within that Area. This determination is to be made based upon operations that occur at each facility. The Area Manager will then receive a report listing applicable document retention requirements (report), which includes:
  1. activity covered;
  2. minimum retention period; and
  3. types of records/documents which must be maintained.
- b. This initial determination shall be completed within 18 months of issuance of this procedure.
- c. In the event of any modification in the operations of the facility or the addition of any new facility or operation, it shall be the responsibility of the Area Manager to notify the Environmental Affairs Section for a determination of whether any change in that facility's record keeping requirements shall be made.
- d. The Environmental Affairs Section shall notify the Area of revisions to be made to



**Distribution Operations**

**Health, Safety and Environmental Standard**

|                               |   |   |
|-------------------------------|---|---|
| Effective Date:<br>02/07/1996 | <b>Retention of Environmental Documents</b> | Standard Number:<br><b>HSE 4400.030(CG)</b><br>P&P 580-10 |
| Supersedes:<br>N/A            |   | Page 3 of 7   |

its document retention requirements which are the result of new or revised regulations.

- e. At least once each calendar year, not to exceed 15 months, the Environmental Affairs Section will distribute an updated listing to each Area Manager.

**4. MAINTENANCE OF DOCUMENTS**

Each Area Manager shall have responsibility for maintaining the required files at a central location within each Area.

- a. A separate file shall be established for each type of environmental issue (e.g., air, water, wastes, etc.) applicable to that location.
- b. The file shall be continuously maintained and updated.
- c. It may also be necessary to maintain a record or file at a facility other than a Service Center. The Environmental Affairs Section shall notify the Area Manager in such instances.
- d. As a result of reporting obligations for certain operations, files may also be required to be maintained and kept current in the Environmental Affairs Section in addition to any other location. Each Area will be instructed as to the applicability of this section.
- e. Additions or revisions to record retention requirements shall be maintained pursuant to Section 3.

In the event of any enforcement action, the periods of retention required pursuant to this policy and procedure and the initial determination or any subsequent determination by the Environmental Affairs Section shall automatically be extended for the duration of such outstanding enforcement action.

**5. TYPES OF ENVIRONMENTAL ISSUES WITH RECORD RETENTION REQUIREMENTS**

For illustrative purposes, this section highlights environmental issues that have environmental record retention requirements and may be associated with CDC operations. The actual report received by an Area will contain specific statutory/regulatory requirements for that Area.

**5.1 Air**

**5.1.1 Data Required for Certain Sources of Air Emissions**

Areas having certain sources of air emissions (e.g., compressor engines at propane - air plants) must maintain the following data:

- a. Files concerning measurements, maintenance activities and



**Distribution Operations**

**Health, Safety and Environmental Standard**

|                               |   |   |
|-------------------------------|---|---|
| Effective Date:<br>02/07/1996 | <b>Retention of Environmental Documents</b> | Standard Number:<br><b>HSE 4400.030(CG)</b><br>P&P 580-10 |
| Supersedes:<br>N/A            |   | Page 4 of 7   |

reporting, etc.

- b. Performance-test measurements, including continuous monitoring system (CMS) or other monitoring devices.
- c. CMS performance evaluations.
- d. CMS or other monitoring-device calibration checks.
- e. Records of adjustments or maintenance performed on these systems or devices.
- f. Such other information required by the Environmental Affairs Section.

**5.1.2 Monitoring Records for Clean Air Act Operating Permits**

Sources falling under operating permits must keep required monitoring records including, but not limited to:

- a. Date, place and time of all sampling and measurements.
- b. Date(s) analyses were performed.
- c. Company or entity that performed the analysis.
- d. Analytical techniques or methods used.
- e. Results of such analyses.
- f. Operating conditions as existed at the time of sampling or measurement.
- g. The Title V operating permit.

**5.2 Water**

**5.2.1 Permits to Discharge Wastes**

Areas holding or applying for permits to discharge wastes into any waterway pursuant to a national or state pollution discharge elimination program, including storm water, must maintain the following:

- a. Records of all data used to complete National Pollution Discharge Elimination System (NPDES) permit applications, and any supplemental information submitted for these permits, as well as the permit itself.
- b. Any required discharge monitoring reports, pollution prevention plans, or other associated documents as specified by actual permits issued by the regulating agencies.



**Distribution Operations**

**Health, Safety and Environmental Standard**

|                               |   |   |
|-------------------------------|---|---|
| Effective Date:<br>02/07/1996 | <b>Retention of Environmental Documents</b> | Standard Number:<br><b>HSE 4400.030(CG)</b><br>P&P 580-10 |
| Supersedes:<br>N/A            |   | Page 5 of 7   |

**5.2.2 Underground Injection or Fluid Disposal Wells**

Areas having permitted underground injection or fluid disposal wells must maintain:

- a. the permit.
- b. a complete copy of the spill prevention control and countermeasure plan (SPCC) on file in case a regulator wants to review it. The SPCC plan must be kept at the site falling under this regulation only if the facility is normally attended at least eight hours per day, or at the nearest field office.
- c. manifests, operating records and reports, as required by the permit.

**5.2.3 Wetlands (Dredged or Fill Material)**

Each permit issued under a state program will contain monitoring, reporting and record keeping requirements.

**5.2.4 Drinking Water**

Areas having of a public water system shall retain the following:

- a. Records of bacteriological analysis and chemical analysis, including date, place and time of sampling and the identity of person collecting sample, date of analysis, laboratory, and results of analysis;
- b. Records of actions taken to correct violations.
- c. Reports of surveys of water system.
- d. Record of variances or exemptions granted.

**5.3 Waste**

**5.3.1 Hazardous Waste Generators**

Areas that are generators of hazardous waste shall retain the following:

- a. Manifests.
- b. Biennial reports or exception reports.
- c. Records of any test results, waste analyses, or other determinations made.
- d. Copies of a small quantity generator's reclamation agreement.



**Distribution Operations**

**Health, Safety and Environmental Standard**

|                               |   |   |
|-------------------------------|---|---|
| Effective Date:<br>02/07/1996 | <b>Retention of Environmental Documents</b> | Standard Number:<br><b>HSE 4400.030(CG)</b><br>P&P 580-10 |
| Supersedes:<br>N/A            |   | Page 6 of 7   |

**5.3.2 Polychlorinated Biphenyls (PCB)**

- a. Areas where a PCB spill has occurred must, under the Federal PCB Spill Cleanup Policy, maintain records documenting the cleanup, including records and certification of decontamination.
- b. In addition to maintaining the manifest signed by the storage/disposal facility, generators of PCB waste must also maintain a copy of each manifest signed in accordance with the regulations until the generator receives a signed copy from the designated commercial storage or disposal facility which received the PCB waste.

**5.4 Underground Storage Tanks (UST)**

Areas having underground storage tanks must maintain documents pertaining to the following:

- a. Analysis of site-corrosion potential if corrosion-protection equipment is not used.
- b. Operation of corrosion protection equipment.
- c. UST system repairs.
- d. Compliance with release-detection requirements.
- e. Results of the site investigation conducted at permanent closure.
- f. All written performance claims pertaining to release-detection system and the manner in which these claims have been justified or tested by the equipment manufacturer or installer.
- g. Results of sampling, testing, monitoring and tank-tightness testing.
- h. Calibration, maintenance and repair of release-detection equipment.
- i. Schedules of required calibration and maintenance provided by the release-detection equipment manufacturer.
- j. Records of all financial mechanisms used to demonstrate "financial responsibility" for regulated UST's.

**5.5 Community Right to Know**

Areas subject to the toxic chemical release reporting (Community Right to Know) must maintain the following records:

- a. A copy of EPA Form R.





**Distribution Operations**

**Health, Safety and Environmental Standard**

|                               |   |   |
|-------------------------------|---|---|
| Effective Date:<br>02/07/1996 | <b>Retention of Environmental Documents</b> | Standard Number:<br><b>HSE 4400.030(CG)</b><br>P&P 580-10 |
| Supersedes:<br>N/A            |   | Page 7 of 7   |

- b. All supporting materials and documentation used to make the compliance determination that the facility or establishment is a covered facility.
- c. Documentation supporting any claimed allowable exemption.
- d. Data supporting the determination of whether a threshold applies to each toxic chemical.
- e. Data supporting calculations of the quantity of each toxic chemical released to the environment or transferred to an off-site location.
- f. Documentation supporting the dates of manufacturing, processing, or use of regulated toxic chemicals.
- g. Receipts or manifests associated with the transfer of each applicable toxic chemical in waste to off-site locations.



**Distribution Operations**

## Health, Safety and Environmental Standard

|                               |                                   |   |
|-------------------------------|-----------------------------------|---|
| Effective Date:<br>01/01/2013 | <b>Hazardous Waste Management</b> | Standard Number:<br><b>HSE 4400.040</b> |
| Supersedes:<br>N/A            |                                   | Page 1 of 29                            |

Companies Affected:

|                                 |   |   |
|---------------------------------|---|---|
| <input type="checkbox"/> NIPSCO | <input checked="" type="checkbox"/> CGV | <input checked="" type="checkbox"/> CMD |
|                                 | <input checked="" type="checkbox"/> CKY | <input checked="" type="checkbox"/> COH |
|                                 | <input checked="" type="checkbox"/> CMA | <input checked="" type="checkbox"/> CPA |

**REFERENCE** 40 CFR 260 through 40 CFR 268

### 1. APPLICABILITY/SCOPE

These procedures enable employees to manage hazardous wastes generated at NiSource Gas Distribution (NGD) facilities and/or by NGD activities in an environmentally responsible manner..

The following materials are not covered in these procedures: contaminated soil from underground storage tank removals, construction spoils, municipal waste, and special waste (e.g., PCB, asbestos, mercury, etc.).

See Exhibit B for a summary of state requirements.

### 2. RESPONSIBILITY

The generating facility (e.g., Operating Center, MOD, other office buildings) is responsible for informing the HSE staff in a timely manner whenever wastes are generated and conducting required inspections. The HSE staff will ensure that all wastes are characterized and managed properly.

### 3. WASTE CLASSIFICATION

The first step in waste classification is to determine if the waste is a solid waste as defined in the Resource Conservation and Recovery Act (RCRA). A solid waste means any garbage, refuse, sludge, liquid, and other discarded material requiring disposal. All solid waste must be evaluated to determine if it is a hazardous waste. It should then be determined if the waste is excluded from regulation under 40 CFR 261.4. (Note: The exclusion that may apply to natural gas distribution is the narrowly defined exclusion for fluids associated with natural gas exploration, development or production.) If the waste is not excluded, then it should be determined if the waste is a listed hazardous waste in 40 CFR 261.31.

*This document is considered CONTROLLED only when viewed electronically on the Company's intranet. Printed or other electronic copies may not be current, and the intranet version should be used to verify.*



Distribution Operations

Health, Safety and Environmental Standard

|                               |                                   |   |
|-------------------------------|-----------------------------------|---|
| Effective Date:<br>01/01/2013 | <b>Hazardous Waste Management</b> | Standard Number:<br><b>HSE 4400.040</b> |
| Supersedes:<br>N/A            |                                   | Page 2 of 29                            |

(There are two other lists of hazardous waste found at 40 CFR 261.32 and 261.33, but these wastes are generally not representative of the hazardous wastes generated by NGD's operations. If a new or unusual waste stream is generated, then checking these lists may be appropriate.) If the waste is not listed, then the waste will be tested by a laboratory to determine if the waste exhibits any hazardous waste characteristics as defined below.

**3.1 Ignitability (40 CFR 261.21)**

A solid waste exhibits the characteristic of ignitability if: 1) it is a liquid having a flashpoint of less than 140 degrees F; 2) it is not a liquid and is capable under normal conditions of causing fire through friction, absorption of moisture or chemical changes, and when ignited, burns so vigorously that it creates a hazard; 3) it is an ignitable compressed gas as defined by the US Department of Transportation (DOT) in 49 CFR 173; or 4) it is an oxidizer as defined by DOT. A solid waste that exhibits the characteristic of ignitability has the EPA Hazardous Waste Number of D001. Ignitable hazardous wastes are capable of causing a fire or making a fire more intense.

**3.2 Corrosivity (40 CFR 261.22)**

A solid waste exhibits the characteristic of corrosivity if: 1) it is aqueous and has a pH less than or equal to 2 or greater than or equal to 12.5; or 2) it is a liquid and corrodes steel at a specified rate. A solid waste that exhibits the characteristic of corrosivity has the EPA Hazardous Waste Number of D002. Corrosive hazardous wastes are capable of corroding metal drums.

**3.3 Reactivity (40 CFR 261.23)**

A solid waste exhibits the characteristic of reactivity if it is unstable and can react violently or explode during handling. The regulation is in narrative form since testing procedures for reactivity are not available for every situation. A solid waste that exhibits the characteristic of reactivity has the EPA Hazardous Waste Number of D003.

**3.4 Toxicity (40 CFR 261.24)**

A solid waste exhibits the characteristic of toxicity if, using the Toxicity Characteristic Leaching Procedure (TCLP), the extract from a representative sample contains any of the contaminants in concentrations equal to or greater than the amounts listed in Table 1.



Distribution Operations

Health, Safety and Environmental Standard

|                               |                                   |   |
|-------------------------------|-----------------------------------|---|
| Effective Date:<br>01/01/2013 | <b>Hazardous Waste Management</b> | Standard Number:<br><b>HSE 4400.040</b> |
| Supersedes:<br>N/A            |                                   | Page 3 of 29                            |

Table 1  
Maximum Concentration of TCLP Contaminants

| <u>EPA ID Number</u> | <u>Contaminant</u>   | <u>Regulatory Level (mg/l)</u> | <u>EPA ID Number</u> | <u>Contaminant</u>         | <u>Regulatory Level (mg/l)</u> |
|----------------------|----------------------|--------------------------------|----------------------|----------------------------|--------------------------------|
| D004                 | Arsenic              | 5                              | D031                 | Heptachlor and its epoxide | 0.008                          |
| D005                 | Barium               | 100                            | D032                 | Hexachlorobenzene          | 0.13                           |
| D018                 | Benzene              | 0.5                            | D033                 | Hexachlorobutadiene        | 0.5                            |
| D006                 | Cadmium              | 1                              | D034                 | Hexachloroethane           | 3                              |
| D019                 | Carbon tetrachloride | 0.5                            | D008                 | Lead                       | 5                              |
| D029                 | Chlordane            | 0.03                           | D013                 | Lindane                    | 0.4                            |
| D021                 | Chlorobenzene        | 100                            | D009                 | Mercury                    | 0.2                            |
| D022                 | Chloroform           | 6                              | D014                 | Methoxychlor               | 10                             |
| D007                 | Chromium             | 5                              | D035                 | Methyl ethyl ketone        | 200                            |
| D023                 | o-Cresol             | 200                            | D036                 | Nitrobenzene               | 2                              |
| D024                 | m-Cresol             | 200                            | D037                 | Pentachlorophenol          | 100                            |
| D025                 | p-Cresol             | 200                            | D038                 | Pyridine                   | 5                              |
| D026                 | Cresol               | 200                            |                      |                            |                                |
| D016                 | 2,4-D                | 10                             | D010                 | Selenium                   | 1                              |
| D027                 | 1,4-Dichlorobenzene  | 7.5                            | D011                 | Silver                     | 5                              |
| D028                 | 1,2-Dichloroethane   | 0.5                            | D039                 | Tetrachloroethylene        | 0.7                            |
| D029                 | 1,1-Dichloroethylene | 0.7                            | D015                 | Toxaphene                  | 0.5                            |
| D030                 | 2,4-Dinitrotoluene   | 0.13                           | D040                 | Trichloroethylene          | 0.5                            |
| D012                 | Endrin               | 0.02                           | D041                 | 2,4,5-Trichlorophenol      | 400                            |
|                      |                      |                                | D042                 | 2,4,6-Trichlorophenol      | 2                              |
|                      |                      |                                | D017                 | 2,4,5-TP (Silvex)          | 1                              |
|                      |                      |                                | D043                 | Vinyl chloride             | 0.2                            |

**4. GENERATOR CLASSIFICATION, ACCUMULATION, AMOUNTS, AND TIME**

Hazardous waste generators may be classified as Conditionally Exempt Small Quantity Generators (CESQGs) or Small Quantity Generators (SQGs) or Large Quantity Generators (LQGs). Thresholds for monthly waste generation are as follows.



Distribution Operations

Health, Safety and Environmental Standard

|                               |                                   |   |
|-------------------------------|-----------------------------------|---|
| Effective Date:<br>01/01/2013 | <b>Hazardous Waste Management</b> | Standard Number:<br><b>HSE 4400.040</b> |
| Supersedes:<br>N/A            |                                   | Page 4 of 29                            |

- CESQG\*-less than 100 kilograms (kg) per month. This is 220 pounds or about ½ drum.  
 \* MA regulation does not use the term Conditionally Exempt Small Quantity Generator, but rather uses the term Very Small Quantity Generator (VSQG). See the Massachusetts Supplement in Exhibit B.
- SQG-Between 100 kg and 1000 kg per month. This is between 220 to 2200 pounds or about ½ drum to 4 or 5 drums.
- LQG-More than 1000 kg per month.
- A number of the NGD facilities do generate hazardous waste and the majority of these facilities fall within the CESQG classification (VSQG for CMA)..

The amounts and time that hazardous waste may be accumulated on-site are based on the generator status of the facility. A summary of these requirements is shown in Table 2.

Table 2  
 Hazardous Waste Generator Storage Requirements

| <u>Generator Status</u> | <u>Maximum Amount Accumulated On-Site</u>         | <u>Maximum Days Allowed On-Site</u>                                     |
|-------------------------|---|---|
| Conditionally Exempt    | 1000 kilograms, or 2200 pounds (About 4-5 drums)  | No time limit until exceed accumulation limit                           |
| Small Quantity          | 6000 kilograms, or 13,200 pounds (About 30 drums) | 180 days (270 days if disposal facility is greater than 200 miles away) |
| Large Quantity          | No limit  | 90 days   |

**5. EPA HAZARDOUS WASTE NUMBER**

LQG and SQG facilities are required to file a federal or state Notification of Hazardous Waste Activity Form and to obtain an EPA identification number. The notification requires the generator to identify the facility’s generator status and to list the hazardous waste codes anticipated to be generated. A modification to the notification should be submitted to the appropriate agency to reflect observed changes in types or amounts of waste generated.

The notification forms are to be prepared by the HSE staff. The completed Notification of Hazardous Waste Activity form and any acknowledgments back from the regulatory



**Distribution Operations**

**Health, Safety and Environmental Standard**

|                               |                                   |   |
|-------------------------------|-----------------------------------|---|
| Effective Date:<br>01/01/2013 | <b>Hazardous Waste Management</b> | Standard Number:<br><b>HSE 4400.040</b> |
| Supersedes:<br>N/A            |                                   | Page 5 of 29                            |

agencies should be maintained on-site for a period of at least three years. The most current notification should be maintained for the life of the facility. The notification form should be signed by someone with operational management authority for the facility or by the HSE staff.

It is the responsibility of the HSE department to file the Notification of Hazardous Waste Activity Forms.

**6. EMPLOYEE TRAINING**

**6.1 Personnel at Large Quantity Generators (LQG)**

Personnel at LQG facilities who perform hazardous waste management duties are required to have training (classroom or on-the-job) relevant to the duties to which they are assigned. As at minimum, the training must ensure that personnel are familiar with implementation of the site's Contingency Plan and are able to respond to emergencies.

Training must be completed within six months of assignment of hazardous waste management duties. No employees shall perform their hazardous waste duties unsupervised until the training has been completed. Additional training must be conducted, as required, when new or modified hazardous waste duties are assigned.

Refresher training must be conducted annually to review Contingency Plan implementation, emergency response and duties specific to the employee's job descriptions.

The hazardous waste regulations state the following minimum requirements for training: 1) procedures for using, inspecting, repairing and replacing emergency and monitoring equipment; 2) the limits for automatic waste feed cut-off systems; 3) communications or alarm systems; 4) response to fires or explosions; 5) response to groundwater contamination incidents; and 6) shut down of operations.

Training records for LQG hazardous waste personnel must be maintained for current employees until facility closure. Training records for former employees must be retained for at least three years from the last date of employment at the facility. These training records include: 1) job title for each hazardous waste management position and the name of the employee filling each position; 2) job description for each hazardous waste management position; and 3) description and documentation of required introductory and continuing training.

**6.2 Personnel at Small Quantity Generators (SQG)**

Personnel at SQG facilities must be thoroughly familiar with proper hazardous waste handling during normal operations and with emergency procedures. There are no



**Distribution Operations**

**Health, Safety and Environmental Standard**

|                               |                                   |   |
|-------------------------------|-----------------------------------|---|
| Effective Date:<br>01/01/2013 | <b>Hazardous Waste Management</b> | Standard Number:<br><b>HSE 4400.040</b> |
| Supersedes:<br>N/A            |                                   | Page 6 of 29                            |

requirements for annual refresher training, maintenance of training records, or written job descriptions.

**6.3 Personnel at Conditionally Exempt Small Quantity Generators (CESQG)**

There are no specific regulatory requirements for training personnel at CESQG facilities.

**6.4 Responsibility**

It is the responsibility of the facility Manager (with support from the HSE staff , if requested) to ensure that personnel at generator sites are adequately trained in hazardous waste management.

**7. HAZARDOUS WASTE CONTAINER MANAGEMENT**

LGQ and SGQ facilities are required to manage their drums in accordance with federal (40 CFR 265, Subpart I) and state regulations. Tanks shall not be used to accumulate hazardous waste unless the tanks meet all applicable state and federal (40 CFR Part 265, Subpart J) design and operating standards.

Specific requirements for hazardous waste containers and drums are summarized below..

**7.1 Labeling**

Label the drum with the words "HAZARDOUS WASTE" and date of first accumulation. The date of first accumulation is the date that hazardous waste is first placed in the drum. There are additional RCRA labeling requirements before the drum may be transported off site by a licensed hazardous waste transporter.

A hazardous waste label shall be put on the drum that contains the wording "Hazardous Waste - State and Federal law prohibit improper disposal. If found, contact the nearest police or public safety authority or the State or United States Environmental Protection Agency." The generator's name, address, and EPA Identification number shall also be on the label. The hazardous waste codes shall be marked on the label. The proper DOT shipping name shall be put on the label.

There are also drum labeling requirements under OSHA for hazard communication and under DOT for transportation purposes.

**7.2 Storage**

The drum must be compatible with the drummed contents and must be in good condition. During storage, drums must be kept closed (including bungs), except at those times when adding or removing wastes. Drums of hazardous waste should be



|                               |                                   |   |
|-------------------------------|-----------------------------------|---|
| Effective Date:<br>01/01/2013 | <b>Hazardous Waste Management</b> | Standard Number:<br><b>HSE 4400.040</b> |
| Supersedes:<br>N/A            |                                   | Page 7 of 29                            |

stored in a specified area.

Drum storage areas should be located so that a spill from a drum would not be expected to reach surface water, either directly or through a man-made drainage system such as a storm drain. If possible, the drums should be provided with secondary containment that is locked or otherwise secured. Container areas should have restricted public access and should not be subject to flooding.

Adequate aisle space (at least 2.5 feet between double rows) must be maintained between drums to allow for inspection and emergency equipment. Labels should be facing outward.

Incompatible wastes must be segregated from each other within a storage area.

At LQG facilities, ignitable hazardous wastes must be stored a minimum of 50 feet from the property line. No Smoking signs (or equivalent to prevent open flames) must be conspicuously placed wherever ignitable hazardous drums are stored.

Empty drums should be stored in a manner to prevent rainwater accumulation and should be labeled as empty. An empty container is empty if all the waste has been removed by normal means and no more than 1 inch of waste residue remains in the drum.

### **7.3 Inspections**

LQG and SQG facilities must inspect drums of hazardous waste on a weekly basis. CESQG facilities should inspect drums of hazardous waste on a monthly basis. For CMA, VSQG facilities must be inspected weekly. The inspections must be documented in accordance with Form HSE 4400.040-1 (Exhibit A).

LQG and SQG facilities are also required to inspect emergency equipment such as fire extinguishers and spill kits as necessary to ensure proper operation.

The records of drum (and emergency equipment) inspections must be maintained on-site for three years.

Empty hazardous waste drums do not need to be inspected.

### **7.4 Satellite Accumulation Drums**

Federal and state regulations allow a generator to accumulate waste in containers at or near the point of generation where wastes initially accumulate, which is under the control of the operator of the process generating the waste, without having to comply with the 90 or 180 day accumulation time. A satellite accumulation drum must be labeled with the words HAZARDOUS WASTE. No more than 55 gallons of hazardous





**Distribution Operations**

## Health, Safety and Environmental Standard

|                               |                                   |   |
|-------------------------------|-----------------------------------|---|
| Effective Date:<br>01/01/2013 | <b>Hazardous Waste Management</b> | Standard Number:<br><b>HSE 4400.040</b> |
| Supersedes:<br>N/A            |                                   | Page 8 of 29                            |

waste may be accumulated at the point of generation. A satellite accumulation drum must be in good condition, compatible with the drummed contents, and always kept closed unless adding or removing wastes. The date that a satellite accumulation drum becomes full is the date of first accumulation. The on-site accumulation time is then applicable. A satellite accumulation drum must be moved to a designated hazardous waste drum storage area within three days of generating 55 gallons.

### 8. HAZARDOUS WASTE TRACKING

LQG and SQG facilities need to demonstrate compliance with on-site hazardous waste accumulation periods and quantity limitations. In order to provide this documentation if requested by a regulatory agency waste manifests should be maintained.

### 9. EMERGENCY PREPAREDNESS

The federal rules concerning preparedness and prevention (40 CFR 265.30 to 40 CFR 265.37) apply to LQG and SQG facilities.

#### 9.1 Emergency Equipment Requirements

LQG and SQG facilities must be equipped with the following.

- a. Internal communications or alarm systems to notify facility personnel of an emergency.
- b. Devices, including telephone, capable of summoning emergency assistance.
- c. Portable fire extinguishers, fire control equipment, spill control equipment and decontamination equipment.
- d. Adequate water volume and pressure.

#### 9.2 Emergency Equipment Inspection Requirements

Emergency equipment, such as fire extinguishers and spill kits, at LQG and SQG facilities shall be inspected as necessary. The inspection shall be documented on Form HSE 4400.040-1.

#### 9.3 Emergency Equipment Testing Requirements

Facility communications, alarm systems, fire protection systems, and spill control equipment must be tested and maintained as necessary to ensure proper operation. The testing shall be documented and documentation shall be maintained for three years.



**Distribution Operations**

**Health, Safety and Environmental Standard**

|                               |                                   |   |
|-------------------------------|-----------------------------------|---|
| Effective Date:<br>01/01/2013 | <b>Hazardous Waste Management</b> | Standard Number:<br><b>HSE 4400.040</b> |
| Supersedes:<br>N/A            |                                   | Page 9 of 29                            |

**9.4 Required Aisle Space**

Adequate aisle space must be maintained to ensure unobstructed movement during emergencies. This is about 2.5 feet between double rows of drums.

**9.5 Arrangements With Local Authorities**

LQG and SQG facilities must attempt to make the following arrangements according to the types of wastes on site and the potential need for emergency services.

- a. Familiarize local emergency response personnel with facility layout, types of hazardous waste, entrances and evacuation routes.
- b. Designate primary police and fire department where more than one is likely to respond to an emergency.
- c. Obtain agreements with state emergency response personnel.
- d. Familiarize local hospitals with properties of hazardous waste and types of injuries likely to occur as a result of an emergency at the facility.

Such attempts at familiarization and agreements with local emergency response personnel should be documented and the documentation should remain on site. It is the responsibility of the HSE staff to make these arrangements

**10. OPERATING PROCEDURES**

One of the primary objectives of the state and federal hazardous waste regulations is to prevent or minimize the occurrence of emergency situations. Many procedures can be implemented to reduce the potential of fire, explosions, or release of hazardous wastes. To prevent fire from occurring, facilities are carefully maintained.

Good housekeeping will minimize the possibility of auto-ignition. Ignitable hazardous wastes are segregated from other materials. Smoking is prohibited in the hazardous waste storage area. Sources of sparking will be reviewed and eliminated from dangerous areas.

To prevent the release of hazardous wastes from drums, the following procedures shall be implemented at NGD facilities.

- a. Remove samples of drummed material in a manner to prevent release.
- b. Keep drums covered with lids and bungs that are securely fastened.
- c. Open and transfer the contents from one drum at a time.
- d. Store empty drums with lids securely in place, label as empty, and lay empty drums on their sides, if space permits, to prevent accumulation of precipitation.
- e. Inspect hazardous waste drums for adequate lids, checking drum base and the



**Distribution Operations**

**Health, Safety and Environmental Standard**

|                               |                                   |   |
|-------------------------------|-----------------------------------|---|
| Effective Date:<br>01/01/2013 | <b>Hazardous Waste Management</b> | Standard Number:<br><b>HSE 4400.040</b> |
| Supersedes:<br>N/A            |                                   | Page 10 of 29                           |

surrounding area for leakage. (Weekly inspections are required at LQG and SQG facilities, CESQG's should inspect accumulation areas monthly. See Form HSE 4400.040-1, Exhibit A.)

- f. Transfer contents from a drum not in good condition to a drum in good condition as soon as suspect drum is detected. Evidence of a defective drum includes visual pitting, creases, rust and/or misshapen sides and lids.
- g. During drum shipment off-site, stage all drums to be shipped, check all drums for tight lids and bungs. Stay with the transporter to ensure drums are loaded carefully. No leaking drum or inadequately lidded or labeled drum will be loaded onto the truck.

SQG facilities are also required to post the following information next to the facility telephone.

- a. Name and telephone number of emergency coordinator.
- b. Location of fire extinguisher, spill control material, and fire alarm (if present).
- c. Telephone number of the fire department.

**11. CONTINGENCY PLAN**

Federal and state hazardous waste regulations require that a LQG facility have a Contingency Plan. The plan must be written and maintained at the facility. Copies of the Contingency Plan must be filed with local police and fire departments, hospitals, and emergency response teams. The Contingency Plan documents the actions that will be taken in response to fires, explosions, or releases of hazardous waste.

The plan also must include names and phone numbers of Company emergency response personnel and of local emergency contacts.

**12. EMERGENCY PROCEDURES**

**12.1 Emergency Coordinator**

Each LQG and SQG shall designate an Emergency Coordinator. The Emergency Coordinator is someone at the facility or on call who can be available to respond to an emergency by reaching the facility in a short period of time. The Emergency Coordinator is responsible for coordinating emergency efforts. The Emergency Coordinator should be trained in applicable hazardous waste management as determined by the HSE staff.

The Emergency Coordinator is responsible for assessing the severity of the situation



**Distribution Operations**

**Health, Safety and Environmental Standard**

|                               |                                   |   |
|-------------------------------|-----------------------------------|---|
| Effective Date:<br>01/01/2013 | <b>Hazardous Waste Management</b> | Standard Number:<br><b>HSE 4400.040</b> |
| Supersedes:<br>N/A            |                                   | Page 11 of 29                           |

involving the release of hazardous waste or its constituents to the environment. Decisions on appropriate response, notification, and reporting requirements will be based on these guidelines.

- a. Any conditions which could result in a fire, explosion or release of hazardous waste or the detection of an actual fire, explosion or release are to be reported immediately to the Emergency Coordinator by the employee discovering the situation.
- b. If the situation results from a condition which could result in a fire, explosion or release involving hazardous waste, the Emergency Coordinator will determine the actions necessary to correct the situation. The Emergency Coordinator should contact the HSE staff for advice. Corrective actions should be implemented by the facility to eliminate the threatening conditions and to take reasonable measures to ensure that fires, explosions, releases do not occur, recur, or spread.
- c. If the situation results from an actual fire, explosion or release involving hazardous waste, the Emergency Coordinator will notify all site personnel about the emergency and will determine if employees need to be evacuated. The Emergency Coordinator will direct the response activities required to contain and extinguish fires and to contain any released hazardous waste. Only specially trained employees will be utilized in emergency response activities.
- d. The Emergency Coordinator will try to determine the source of the hazardous waste release or fire, the characteristics of the hazardous waste, the possibility of off-site property damage, and the need for off-site emergency service organizations.

The HSE staff can assist the Emergency Coordinator in this determination.

**12.2 Emergency Procedures**

The HSE staff should be contacted immediately by the Emergency Coordinator or other employee in the event of an emergency. The state or local emergency response agencies should be notified immediately if their help will be needed to respond to a fire or spill. Consideration must be given to determine if a spill of hazardous waste is reportable under the spill reporting requirements of the Clean Water Act, the Comprehensive Environmental Response, Compensation, and Liability Act (CERCLA), and RCRA. It is the responsibility of the Company, with support from HSE, to determine reporting requirements.

**12.2.1 Fire**

The following actions will be taken in case of a fire.



Distribution Operations

## Health, Safety and Environmental Standard

|                               |                                   |   |
|-------------------------------|-----------------------------------|---|
| Effective Date:<br>01/01/2013 | <b>Hazardous Waste Management</b> | Standard Number:<br><b>HSE 4400.040</b> |
| Supersedes:<br>N/A            |                                   | Page 12 of 29                           |

- a. A fire extinguisher will be used to put out and control the fire. If the fire cannot be controlled with a fire extinguisher, then the local fire department shall be called by the facility.
- b. Containers that may have been affected by the fire will be examined for damage. If the containers are not in good structural condition, then the contents will be placed in new containers.
- c. The fire extinguisher will be replaced or recharged as soon as possible.

### 12.2.2 Spill

The following actions will be taken in the event of a spill.

- a. If the spill drains towards a storm sewer, then the spill will be blocked with absorbents.
- b. Shovels will be used to pick up spill residues which will be placed in 55-gallon drums.
- c. The material will be transferred from a damaged drum to a new drum that is properly labeled. The first date of accumulation is transferred from the damaged to the undamaged drum.
- d. Replace any emergency equipment used and decontaminate by washing reusable equipment. The rinsate (i.e., water containing low concentrations of contaminants resulting from the cleaning of the container) must be containerized and characterized for proper handling and labeling.
- e. If the spill is beyond the capability of employees, then a spill response contractor will be called immediately. The HSE staff will work with the facility to obtain a qualified response firm.
- f. Contaminated personal protective equipment, clothing, rags, soils and other debris that have come in contact with the hazardous waste should be placed in United Nations (UN) approved containers and managed as hazardous waste.

### 12.3 Post Emergency Requirements

After an emergency involving hazardous waste, the HSE staff will ensure that the recovered waste and contaminated material are managed as a hazardous waste. A report must be prepared for a LQG site if the Contingency Plan is implemented. This requirement is for LQGs only. Within fifteen (15) days after the emergency, the HSE staff will prepare the written report.



## Health, Safety and Environmental Standard

### Distribution Operations

|                               |                                   |   |
|-------------------------------|-----------------------------------|---|
| Effective Date:<br>01/01/2013 | <b>Hazardous Waste Management</b> | Standard Number:<br><b>HSE 4400.040</b> |
| Supersedes:<br>N/A            |                                   | Page 13 of 29                           |

If fire or spill response organizations have been notified, then the Company will inform the regulatory agencies and local fire and police departments when the affected area is cleaned up.

### 13. HAZARDOUS WASTE MANIFEST SYSTEM

#### 13.1 Manifest

LQG and SQG facilities must use the manifest system for hazardous waste transport and disposal (40 CFR 262.20 to 262.23). CESQG facilities are not required to use the manifest but are required to ensure that hazardous wastes are sent to a licensed Treatment, Storage, or Disposal (TSD) facility. Most CESQG facilities use the hazardous waste manifest since transporters and TSD facilities generally require a manifest in order to pick up and dispose of hazardous wastes from a CESQG. Each hazardous waste shipment from the generator site must be documented on an approved federal or state hazardous waste manifest. The manifest should identify at least one TSD facility.

Manifests must be identified by a unique manifest number. One copy of the hazardous waste manifest should be retained by the generator at the time of waste shipment, while the remaining copies should be given to the transporter. A signed copy of the manifest should be received by a LQG within 45 days and should be received by a SQG within 60 days of the date the waste was shipped off-site.

It is the responsibility of the generator to ensure that the hazardous waste manifest is accurately completed. The HSE staff should be contacted if generator site personnel have any questions about the accuracy of the manifest.

#### 13.2 Land Disposal Restrictions

Some wastes are prohibited from land disposal. The original shipment of each restricted waste to a TSD must be accompanied by a Land Disposal Restriction or Land Disposal Notification Certification Form (LDR). The LDR form notifies the TSD if the waste is prohibited from disposal in a landfill.

LQG and SQG facilities must keep one copy of the LDR form on-site and attach another copy to the manifest being sent to the TSD facility.

#### 13.3 Exception Reports (40 CFR 262.42)

If a hand signed copy of the manifest has not been received from the TSD facility with 35 days at a LQG and 45 days at a SQG, the facility must contact the transporter and/or the TSD to determine the status of the waste. If a hand-signed copy of the manifest has not been received from the TSD facility within 45 days at a LQG or 60 days at a SQG, the facility must file an Exception Report to the US EPA Regional



**Distribution Operations**

## Health, Safety and Environmental Standard

|                               |                                   |   |
|-------------------------------|-----------------------------------|---|
| Effective Date:<br>01/01/2013 | <b>Hazardous Waste Management</b> | Standard Number:<br><b>HSE 4400.040</b> |
| Supersedes:<br>N/A            |                                   | Page 14 of 29                           |

Administrator. The Exception Report must include the following: a legible copy of the manifest and a cover letter signed by the generator or authorized representative explaining the steps taken to locate the hazardous waste shipment. It is the responsibility of the HSE staff if requested, to track the manifest document return. The HSE staff will prepare any manifest exception reports.

Hazardous waste manifests, LDR forms, supporting waste determination documentation, sample analysis and exception reports must be retained for three years.

### 14. HAZARDOUS WASTE REPORTS

A LQG facility is required to submit a biennial report to the EPA by March 1st of each even numbered year, unless otherwise obligated by the state to comply with other reporting requirements. The biennial report must include the following.

- a. Generator name, address, EPA identification number.
- b. Calendar year covered by the report.
- c. Name, address and EPA identification number of each TSD which accepted the hazardous waste.
- d. Name and EPA identification number of every transporter used to transport hazardous waste during the reporting year.
- e. Description, EPA hazardous waste number, DOT hazard class, and quantity of each hazardous waste shipped off site during the reporting year, listed by EPA identification number of each TSD where waste was shipped.
- f. Description of waste reduction efforts.
- g. Description of changes in volume and toxicity of the waste.
- h. Certification signed by generator or authorized representative.

Annual/biennial reports should be retained for at least three years from the due date of the report. State reporting requirements are summarized in Exhibit B.

### 15. WASTE MINIMIZATION

Federal regulations require LQG facilities to prepare Waste Minimization Plans. A LQG facility certifies that there is a waste minimization program for the facility when the manifest is signed by the generator on line 16. A SQG certifies that good faith efforts have been made to minimize waste generation when the generator signs the manifest (line 16). Waste minimization efforts are included in the biennial hazardous waste report filed by a LQG. Many states have specific requirements for waste minimization, or if not, the states have adopted the federal requirements. A completed waste minimization plan should be maintained on site and updated as significant changes occur. A summary of the state



**Distribution Operations**

**Health, Safety and Environmental Standard**

|                               |                                   |   |
|-------------------------------|-----------------------------------|---|
| Effective Date:<br>01/01/2013 | <b>Hazardous Waste Management</b> | Standard Number:<br><b>HSE 4400.040</b> |
| Supersedes:<br>N/A            |                                   | Page 15 of 29                           |

requirements is included in Exhibit B.

**16. RECORD KEEPING**


Hazardous waste manifests, LDR forms, sample analyses, exception reports, documentation of weekly inspections, training records, and annual reports must be retained at LQG and SQG facilities for at least three years. If the facility is unmanned, then the records shall be maintained at the nearest manned location




|                               |                                   |   |
|-------------------------------|-----------------------------------|---|
| Effective Date:<br>01/01/2013 | <b>Hazardous Waste Management</b> | Standard Number:<br><b>HSE 4400.040</b> |
| Supersedes:<br>N/A            |                                   | Page 16 of 29                           |

**EXHIBIT A**

**HAZARDOUS WASTE STORAGE AREA & EMERGENCY  
EQUIPMENT INSPECTION CHECKLIST**





Inspector Name:

Location of Inspection:

Job Order No.

Date:

Time:

Total Number of Containers:

|   |                       | YES                   | NO                    |
|---|-----------------------|-----------------------|-----------------------|
| 1. Is the area free of debris and other materials?  | <input type="radio"/> | <input type="radio"/> | <input type="radio"/> |
| 2. Is the ground clean and dry?   | <input type="radio"/> | <input type="radio"/> | <input type="radio"/> |
| 3. Are container tops free of spillage?   | <input type="radio"/> | <input type="radio"/> | <input type="radio"/> |
| 4. Is the area free of spills or leaks?   | <input type="radio"/> | <input type="radio"/> | <input type="radio"/> |
| 5. Are all of the containers in good condition?<br><small>(free of dents and corrosion, not bulging, or otherwise deteriorating?)</small> | <input type="radio"/> | <input type="radio"/> | <input type="radio"/> |
| 6. Are all containers properly closed?  | <input type="radio"/> | <input type="radio"/> | <input type="radio"/> |
| 7. Are containers properly labeled?   | <input type="radio"/> | <input type="radio"/> | <input type="radio"/> |
| 8. Is the following information on the labels filled out?   | <input type="radio"/> | <input type="radio"/> | <input type="radio"/> |
| Generator name and address  | <input type="radio"/> | <input type="radio"/> | <input type="radio"/> |
| Accumulation start date   | <input type="radio"/> | <input type="radio"/> | <input type="radio"/> |
| Contents  | <input type="radio"/> | <input type="radio"/> | <input type="radio"/> |
| Physical state (liquid, solid)  | <input type="radio"/> | <input type="radio"/> | <input type="radio"/> |
| Hazardous properties  | <input type="radio"/> | <input type="radio"/> | <input type="radio"/> |
| 9. Is the information on the labels legible?  | <input type="radio"/> | <input type="radio"/> | <input type="radio"/> |
| 10. Have wastes been disposed of within the allowable accumulation time?  | <input type="radio"/> | <input type="radio"/> | <input type="radio"/> |
| 11. Are the containers compatible with their contents?  | <input type="radio"/> | <input type="radio"/> | <input type="radio"/> |
| 12. Are incompatible wastes stored separately?  | <input type="radio"/> | <input type="radio"/> | <input type="radio"/> |
| 13. Is there adequate aisle space? (2.5 feet)   | <input type="radio"/> | <input type="radio"/> | <input type="radio"/> |
| 14. Is secondary containment in place and effective?  | <input type="radio"/> | <input type="radio"/> | <input type="radio"/> |
| 15. Do fire extinguisher(s) have an up-to-date inspection date?   | <input type="radio"/> | <input type="radio"/> | <input type="radio"/> |
| 16. Are spill kits in good working order?   | <input type="radio"/> | <input type="radio"/> | <input type="radio"/> |


Describe any observations for items checked 'NO'.

Corrective actions required.

**Notes:**

- 1) Inspections must be conducted on a routine basis (LQG / SQG = Weekly / CESQG = Monthly)
- 2) Maintain checklist as documentation of this requirement
- 3) File in the Environmental file at the applicable location





***Distribution Operations***

**Health, Safety and Environmental Standard**

|                               |                                   |   |
|-------------------------------|-----------------------------------|---|
| Effective Date:<br>01/01/2013 | <b>Hazardous Waste Management</b> | Standard Number:<br><b>HSE 4400.040</b> |
| Supersedes:<br>N/A            |                                   | Page 17 of 29                           |

**EXHIBIT B  
(1 OF 13)**

**STATE SUPPLEMENTS**



**Distribution Operations**

**Health, Safety and Environmental Standard**

|                               |                                   |   |
|-------------------------------|-----------------------------------|---|
| Effective Date:<br>01/01/2013 | <b>Hazardous Waste Management</b> | Standard Number:<br><b>HSE 4400.040</b> |
| Supersedes:<br>N/A            |                                   | Page 18 of 29                           |

**EXHIBIT B  
(2 OF 13)**

**Kentucky Supplement**

The Commonwealth of Kentucky (KY) has adopted hazardous waste regulations and has been authorized by the US EPA to enforce its hazardous waste regulations in lieu of and in certain cases in addition to the federal hazardous waste regulations.

**Classification of Hazardous Waste Generator Sites**

The state classification for large quantity and small quantity generators is the same as the federal regulations. The authorized monthly generation criteria for each of these classifications is also the same as the federal regulations. In order to be classified as small quantity generator, a generator must generate less than 1,000 kg during a calendar month in every month of a given calendar year.

Under KY hazardous waste regulations, a facility that generates less than 100 kg of hazardous waste in any given month is classified as a limited quantity generator. This classification is generally equivalent to the conditionally exempt small quantity generator classification in the federal regulations.

**Notification of Regulated Activity**

The KY waste regulations require large quantity and small quantity generators to submit an initial registration of hazardous waste activity to the state, on forms prescribed by the state and to obtain an EPA identification number. This registration is equivalent to the federal Notification of Regulated Activity. Thereafter, at least 30 days before the expiration date shown on the certificate of registration issued by the state, large quantity and small quantity generators must submit an annual registration renewal, in order for the registration to remain valid.

Limited quantity (conditionally exempt small quantity) generators are not required to register with the state or obtain an EPA identification number. However, in certain cases, it may be necessary to obtain an EPA identification number for disposal purposes.

**Hazardous Waste Assessments**

KYDEP requires that LQG and SQG facilities complete an annual hazardous waste assessment form and pay a fee based on the quantities and types of hazardous waste shipped off-site and kept on-site. The assessments are generally due March 1 of each year for the preceding year.



**Distribution Operations**

**Health, Safety and Environmental Standard**

|                               |                                   |   |
|-------------------------------|-----------------------------------|---|
| Effective Date:<br>01/01/2013 | <b>Hazardous Waste Management</b> | Standard Number:<br><b>HSE 4400.040</b> |
| Supersedes:<br>N/A            |                                   | Page 19 of 29                           |

**EXHIBIT B  
(3 OF 13)**

**Limitations on the Accumulation of Hazardous Waste at Generator Site**

The hazardous waste accumulation period and quantity limitations contained in the KY hazardous waste regulations are the same as the federal regulations. The limitations for conditionally exempt small quantity generators in the federal regulations are applicable to the KY limited quantity generators.

**Inspections of Emergency Equipment**

KY requires that emergency equipment must be tested and maintained as necessary. While not specifically required, it is a best management practice to document weekly inspections along with hazardous waste drum inspections.

**Use of Manifests**

KY requires the use of hazardous waste manifests for the transportation and disposal of hazardous waste but does not provide state hazardous waste manifests. KY regulations regarding the use of hazardous waste manifests are the same as the federal regulations.

**Hazardous Waste Reports**

Large quantity generators are required to file an annual hazardous waste report.

**Pollution Prevention Requirements**

Large quantity generators are required to address their pollution prevention efforts as part of their annual hazardous waste reports. Both large and small quantity generators are required to certify the existence of waste minimization efforts on hazardous waste manifests.



**Distribution Operations**

**Health, Safety and Environmental Standard**

|                               |                                   |   |
|-------------------------------|-----------------------------------|---|
| Effective Date:<br>01/01/2013 | <b>Hazardous Waste Management</b> | Standard Number:<br><b>HSE 4400.040</b> |
| Supersedes:<br>N/A            |                                   | Page 20 of 29                           |

**EXHIBIT B  
(4 OF 13)**

**Maryland Supplement**

The State of Maryland (MD) has adopted hazardous waste regulations and has been authorized by the US EPA to enforce its hazardous waste regulations in lieu of and in certain cases in addition to the federal regulations.

**Classification of Generator Sites**

MD has one small quantity generator category for generators producing less than 100 kilograms (220 lbs. or about 31 gallons) of hazardous waste per month. MD large quantity generators are those facilities that generate more than 100 kg. of hazardous waste in any given month.

**Notification of Regulated Activity**

MD hazardous waste regulations require large quantity generators and small quantity generators to submit a Notification of Regulated Activity and obtain an EPA identification number.

**Limitations on Accumulation of Hazardous Waste at Generator Sites**

The maximum quantity of hazardous waste which small quantity generators may accumulate on-site at any given time is 500 kilograms (1100 pounds or about 157 gallons). The hazardous waste accumulation period for small quantity generators is 180 days. MD small quantity generators can lose their small quantity generator status by accumulating 500 kilograms or more of hazardous waste on-site in any one time or keeping it on-site for more than 180 days.

**Inspection of Emergency Equipment**

MD requires that emergency equipment be tested and maintained as necessary to ensure its proper operation. While not specifically required, it is a best management practice to document the inspections at the same time as the weekly hazardous waste drum inspections.

**Use of Hazardous Waste Manifests**

MD requires the use of hazardous waste manifests for the transportation and disposal of hazardous waste but does not provide state hazardous waste manifests. MD requires a copy of the manifest for hazardous wastes disposed of within MD and requires that MD generators submit a copy of the manifest to the state in which the MD hazardous waste generator is disposing of its hazardous waste.



**Distribution Operations**

**Health, Safety and Environmental Standard**

|                               |                                   |   |
|-------------------------------|-----------------------------------|---|
| Effective Date:<br>01/01/2013 | <b>Hazardous Waste Management</b> | Standard Number:<br><b>HSE 4400.040</b> |
| Supersedes:<br>N/A            |                                   | Page 21 of 29                           |

**EXHIBIT B  
(5 OF 13)**

**Hazardous Waste Reports**

Large and small quantity generators are required to file annual hazardous waste reports.

**Pollution Prevention**

Large and small quantity generators must address pollution prevention efforts in their annual hazardous waste reports and must certify the existence of waste minimization efforts on hazardous waste manifests.



**Distribution Operations**

## Health, Safety and Environmental Standard

|                               |                                   |   |
|-------------------------------|-----------------------------------|---|
| Effective Date:<br>01/01/2013 | <b>Hazardous Waste Management</b> | Standard Number:<br><b>HSE 4400.040</b> |
| Supersedes:<br>N/A            |                                   | Page 22 of 29                           |

**EXHIBIT B  
(6 OF 13)**

### Ohio Supplement

The State of Ohio (OH) has adopted hazardous waste regulations and has been authorized by the US EPA to enforce its hazardous waste regulations in lieu of and in certain cases in addition to the federal regulations.

#### Classification of Hazardous Waste Generator Sites

OH has the same three hazardous waste generator site classifications as the federal regulations. The monthly generation criteria for each classification is also the same as the federal regulations.

#### Notification of Regulated Activity

Large quantity and small quantity generators are required to submit a Notification of Regulated Activity (Notification) and obtain an EPA identification number. Conditionally exempt small quantity generator sites are not required to submit a Notification or obtain an EPA ID No. However, in certain cases, it may be necessary to obtain an EPA identification number for disposal purposes.

#### Limitations on the Accumulation of Hazardous Waste at Generator Sites

The hazardous waste accumulation period and quantity limitations contained in the OH hazardous waste regulations are the same as the federal regulations.

#### Inspection of Emergency Equipment

OH requires weekly, documented inspections of emergency equipment at SQG and LQG facilities.

#### Use of Manifests

OH requires the use of hazardous waste manifests for the transportation and disposal of hazardous waste, but does not provide state hazardous waste manifests. The OH waste regulations regarding the use of hazardous waste manifests are the same as the federal regulations. OH does not require a copy of hazardous waste manifests to be submitted to the state.

#### Hazardous Waste Reports

Large quantity generators are required to file an annual hazardous waste report.



**Distribution Operations**

**Health, Safety and Environmental Standard**

|                               |                                   |   |
|-------------------------------|-----------------------------------|---|
| Effective Date:<br>01/01/2013 | <b>Hazardous Waste Management</b> | Standard Number:<br><b>HSE 4400.040</b> |
| Supersedes:<br>N/A            |                                   | Page 23 of 29                           |

**EXHIBIT B  
(7 OF 13)**

**Pollution Prevention Requirements**

Large quantity generators are required to address their pollution prevention efforts as part of their annual hazardous waste reports. Both large and small quantity generators are required to certify the existence of waste minimization efforts on hazardous waste manifests.





**Distribution Operations**

**Health, Safety and Environmental Standard**

|                               |                                   |   |
|-------------------------------|-----------------------------------|---|
| Effective Date:<br>01/01/2013 | <b>Hazardous Waste Management</b> | Standard Number:<br><b>HSE 4400.040</b> |
| Supersedes:<br>N/A            |                                   | Page 24 of 29                           |

**EXHIBIT B  
(8 OF 13)**

**Pennsylvania Supplement**

The Commonwealth of Pennsylvania (PA) has adopted hazardous waste regulations and has been authorized by the US EPA to enforce its hazardous waste regulations in lieu of and in certain cases in addition to the federal regulations.

**Classification of Hazardous Waste Generator Sites**

PA has the same three hazardous waste generator site classifications as the federal regulations. The monthly generation criteria for each classification are also the same as the federal criteria.

**Notification of Regulated Activity**

PA large and small quantity generators are required to submit a Notification of Regulated Activity (Notification) and obtain an EPA identification number.

**Limitations on Accumulation of Hazardous Waste at Generator Sites**

The hazardous waste accumulation period and quantity limitations for PA large quantity generators are the same as the federal regulations.

**Inspection of Emergency Equipment**

PA requires that emergency equipment be tested and maintained as necessary to ensure its proper operation. While not specifically required, it is a best management practice to document visual inspections at the same time when performing the weekly hazardous waste drum inspections.

**Use of Hazardous Waste Manifests**

PA requires the use of hazardous waste manifests for the transportation and disposal of hazardous waste. PA provides a state hazardous waste manifest and requires the use of its manifest for hazardous waste to be disposed of within PA or hazardous waste generated in PA which is destined for disposal in another state, if the destination state does not require the use of its manifest.

If a PA hazardous waste manifest is utilized for a hazardous waste shipment, the generator must remove copy 6, 7 and 8 at the time of shipment and forward either copy 6 or 7, as indicated on the manifest, to the PA Department of Environmental Protection. If another state's



**Distribution Operations**

**Health, Safety and Environmental Standard**

|                               |                                   |   |
|-------------------------------|-----------------------------------|---|
| Effective Date:<br>01/01/2013 | <b>Hazardous Waste Management</b> | Standard Number:<br><b>HSE 4400.040</b> |
| Supersedes:<br>N/A            |                                   | Page 25 of 29                           |

**EXHIBIT B  
(9 OF 13)**

manifest is used for a hazardous waste shipment from a PA generator site, the generator is to distribute the copies as instructed on the manifest.

**Hazardous Waste Reports**

Large quantity generators are required to file an annual hazardous waste report.

**Pollution Prevention**

Large quantity generators are required to have a source reduction strategy and a written facility plan. This must be updated every five years and when there is a significant change in process or waste generated. Both large and small quantity generators are required to certify the existence of waste minimization efforts on hazardous waste manifests.



**Distribution Operations**

## Health, Safety and Environmental Standard

|                               |                                   |   |
|-------------------------------|-----------------------------------|---|
| Effective Date:<br>01/01/2013 | <b>Hazardous Waste Management</b> | Standard Number:<br><b>HSE 4400.040</b> |
| Supersedes:<br>N/A            |                                   | Page 26 of 29                           |

**EXHIBIT B  
(10 OF 13)**

### Virginia Supplement

The Commonwealth of Virginia (VA) has adopted hazardous waste regulations and has been authorized by the US EPA to enforce its hazardous waste regulations in lieu of and in certain cases in addition to the federal hazardous waste regulations.

#### Classification of Hazardous Waste Generator Sites

VA has the same three hazardous waste generator site classifications as the federal regulations and the monthly generation criteria for each classification is also the same as the federal regulations.

#### Notification of Regulated Activity

Large quantity and small quantity generators are required to submit a Notification of Regulated Activity (Notification) and obtain an EPA identification number. Conditionally exempt small quantity generators are not required to submit a Notification or obtain an EPA identification number. However, in certain cases, it may be necessary to obtain EPA identification number for disposal purposes. Notifications submitted for VA generator sites must specify the exact location of hazardous waste accumulation areas within the Generator Site.

#### Limitations on the Accumulation of Hazardous Waste at Generator Sites

The hazardous waste accumulation period and quantity limitations contained in the VA hazardous waste regulations are the same as the federal regulations.

#### Inspection of Emergency Equipment

VA requires that emergency equipment be tested and maintained as necessary to ensure its proper operation. VA also requires that the inspections be documented and maintained on a log at the facility. It is a best management practice to perform the inspection of emergency equipment at the same time as the weekly hazardous waste drum inspections.

#### Use of Hazardous Waste Manifests

VA requires the use of hazardous waste manifests for the transportation and disposal of hazardous waste, but does not provide state hazardous waste manifests. The VA regulations regarding the use of hazardous waste manifests are the same as the federal regulations.

VA does not require a copy of the hazardous waste manifests to be submitted to The Commonwealth.



**Distribution Operations**

**Health, Safety and Environmental Standard**

|                               |                                   |   |
|-------------------------------|-----------------------------------|---|
| Effective Date:<br>01/01/2013 | <b>Hazardous Waste Management</b> | Standard Number:<br><b>HSE 4400.040</b> |
| Supersedes:<br>N/A            |                                   | Page 27 of 29                           |

**EXHIBIT B  
(11 OF 13)**

**Hazardous Waste Reports**

Large quantity generators are required to file an annual hazardous waste report.

**Pollution Prevention**

Large quantity generators are required to address their pollution prevention efforts as part of their annual hazardous waste reports. Both large and small quantity generators are required to certify the existence of waste minimization efforts on hazardous waste manifests.



**Distribution Operations**

**Health, Safety and Environmental Standard**

|                               |                                   |   |
|-------------------------------|-----------------------------------|---|
| Effective Date:<br>01/01/2013 | <b>Hazardous Waste Management</b> | Standard Number:<br><b>HSE 4400.040</b> |
| Supersedes:<br>N/A            |                                   | Page 28 of 29                           |

**EXHIBIT B  
(12 OF 13)**

**Massachusetts Supplement**  
**310 CMR 30**

The Commonwealth of Massachusetts (MA) has adopted hazardous waste regulations and has been authorized by the US EPA to enforce its hazardous waste regulations in lieu of and in certain cases in addition to the federal hazardous waste regulations.

**Classification of Hazardous Waste Generator Sites**

MA has the same three hazardous waste generator site classifications as the federal regulations and the monthly generation criteria for each classification is also the same as the federal regulations. MA does not use the term Conditionally Exempt Small Quantity Generator, but rather uses the term Very Small Quantity Generator (VSQG). MA lists used oil as a hazardous waste. Contact the Environmental Compliance Manager for accumulation limits of used oil.

**Notification of Regulated Activity**

Large quantity and small quantity generators are required to submit a Notification of Regulated Activity (Notification) and obtain an EPA identification number. VSQG's are required to submit a hazardous waste generator registration form.

**Limitations on the Accumulation of Hazardous Waste at Generator Sites**

The hazardous waste accumulation period and quantity limitations contained in the MA hazardous waste regulations are the same as the federal regulations. Waste oil is included in the generator status determination. VSQG's must follow the same accumulation area requirements as SQG's including weekly inspections.

**Inspection of Emergency Equipment**

MA requires that emergency equipment be tested and maintained as necessary to ensure its proper operation. MA also requires that the inspections be documented and maintained on a log at the facility. It is a best management practice to perform the inspection of emergency equipment at the same time as the weekly hazardous waste drum inspections.

**Use of Hazardous Waste Manifests**

MA requires the use of hazardous waste manifests for the transportation and disposal of hazardous waste including waste oil. VSQG's are also required to use hazardous waste manifests.



**Distribution Operations**

**Health, Safety and Environmental Standard**

|                               |                                   |   |
|-------------------------------|-----------------------------------|---|
| Effective Date:<br>01/01/2013 | <b>Hazardous Waste Management</b> | Standard Number:<br><b>HSE 4400.040</b> |
| Supersedes:<br>N/A            |                                   | Page 29 of 29                           |

**EXHIBIT B  
(13 OF 13)**

MA requires a copy of the hazardous waste manifests to be submitted to the Commonwealth.

**Hazardous Waste Reports**

Large quantity generators are required to file an annual hazardous waste report.

**Pollution Prevention**

Large quantity generators are required to address their pollution prevention efforts as part of their annual hazardous waste reports.



**Health, Safety and Environmental Standard**

**Distribution Operations**

|                               |                                    |   |
|-------------------------------|------------------------------------|---|
| Effective Date:<br>11/01/2013 | <b>Pipeline Liquids Management</b> | Standard Number:<br><b>HSE 4400.050</b> |
| Supersedes:<br>N/A            |                                    | Page 1 of 9                             |

Companies Affected:

|                                 |   |   |
|---------------------------------|---|---|
| <input type="checkbox"/> NIPSCO | <input checked="" type="checkbox"/> CGV | <input type="checkbox"/> CMD            |
|                                 | <input checked="" type="checkbox"/> CKY | <input checked="" type="checkbox"/> COH |
|                                 | <input checked="" type="checkbox"/> CMA | <input checked="" type="checkbox"/> CPA |

**REFERENCE** 40 CFR 260 through 40 CFR 268, 40 CFR 761

**1. APPLICABILITY/SCOPE**

These procedures apply to removal and handling of pipeline liquids encountered by any NiSource Distribution Operation employee. Pipeline liquids include any liquids (free flowing or vapor) that are located in any pipeline or pipeline facility. Pipeline liquids may be a mixture of hydrocarbons that have condensed from natural gas (condensates), water, oil, glycol, and methanol. The hydrocarbon portion of pipeline liquids may have a low flashpoint. Pipeline liquids also may contain polychlorinated biphenyls (PCBs). It is the responsibility of the facility Manager, with support from the state environmental staff and Shared Services Compliance (SSC), to assure that pipeline liquids are managed in an environmentally responsible manner.

**2. CLASSIFICATION OF PIPELINE LIQUIDS**

NiSource may receive pipeline liquids from local producers at some locations (local production fluid). If liquid is removed from the pipeline prior to the point where the local gas enters a distribution line containing gas from any other source, the liquid may be exempt from the hazardous waste regulations. Local production fluid includes hydrocarbons, crude oil, water, and/or brine. The regulatory definition for the exempt produced fluids is difficult to interpret; and the determination to use the exemption should be made by the state environmental staff, with support from SSC. Local production fluid should be removed and handled by NiSource personnel in a manner that is protective of human health, safety, and the environment.

Pipeline liquid, depending on its quality, PCB content, end-use or disposal, is either a co-product, hazardous waste, or a combination hazardous waste and PCB waste. The classification of pipeline liquid is summarized below.

**2.1 Pipeline Liquid Containing Less than 2 ppm PCBs**

This liquid is a co-product and is not a hazardous waste if used as feedstock, as raw material in a manufacturing process, or as a substitute commercial product. This liquid would be a hazardous waste due typically to the benzene concentration and/or low flashpoint if it were burned for energy recovery or were disposed of at an approved hazardous waste facility.

*This document is considered CONTROLLED only when viewed electronically on the Company's intranet. Printed or other electronic copies may not be current, and the intranet version should be used to verify.*



**Distribution Operations**

## Health, Safety and Environmental Standard

|                               |                                    |   |
|-------------------------------|------------------------------------|---|
| Effective Date:<br>11/01/2013 | <b>Pipeline Liquids Management</b> | Standard Number:<br><b>HSE 4400.050</b> |
| Supersedes:<br>N/A            |                                    | Page 2 of 9                             |

### 2.2 Pipeline Liquid Containing 2 ppm PCBs or Greater but Less than 50 ppm PCBs

This pipeline liquid shall not be sold as co-product and shall be managed as a solid or hazardous waste. This liquid is not a PCB waste since the PCB concentration is less than 50 ppm, but it would be hazardous waste if it exhibits any hazardous waste characteristics such as ignitability.

### 2.3 Pipeline Liquid Containing 50 ppm or Greater PCBs

This pipeline liquid is a PCB waste and must be disposed of by incineration at an EPA permitted incinerator. This pipeline liquid is also a hazardous waste if it exhibits a hazardous waste characteristic such as ignitability or toxicity. Any liquid that has been accumulated in a container which has previously contained PCBs at 50 ppm or greater and which has not been decontaminated is a PCB waste and also a hazardous waste if it also exhibits any hazardous waste characteristics.

## 3. REMOVAL AND COLLECTION

Pipeline liquid will be removed from the distribution system and placed into a clean container and reported on Form GS 5300.100-002, Report of Liquid Found (EXHIBIT A), or its equivalent. During removal, equipment that might cause ignition shall not be used, nor shall open flames or smoking be permitted. Personnel shall use personal protective equipment as directed by Health and Safety Specialists.

Pipeline liquid should be removed from pipeline and distribution facilities in a manner to avoid spills or releases. Each NiSource vehicle used in activities that routinely encounter spills should carry an appropriate supply of absorbent materials for spill clean up.

## 4. MANAGEMENT PRIOR TO SAMPLING

Pipeline liquids should be managed as a co-product during the initial transportation, provided that the pipeline liquids are not placed in a container which previously contained PCBs at 50 ppm or greater and which has not been decontaminated. Prior to transporting, pipeline liquids shall be placed in United Nations (UN) approved containers. Pipeline liquids should be taken to a central collection point within 24 hours of removal and collection.

If pipeline liquids are transported in containers of less than eight gallons, then the pipeline liquids are regulated as a material of trade under the hazardous materials transportation regulations. Transportation of pipeline liquids in containers larger than eight gallons is subject to the hazardous materials transportation requirements. No more than 110 gallons of pipeline liquids may be transported in a company vehicle. The DOT shipping name for pipeline liquids is Flammable Liquid, nos (aromatic and aliphatic hydrocarbons), 3, UN1993, III.





**Distribution Operations**

**Health, Safety and Environmental Standard**

|                               |                                    |   |
|-------------------------------|------------------------------------|---|
| Effective Date:<br>11/01/2013 | <b>Pipeline Liquids Management</b> | Standard Number:<br><b>HSE 4400.050</b> |
| Supersedes:<br>N/A            |                                    | Page 3 of 9                             |

The central collection point is a designated location, such as a service center or area office/garage, where pipeline liquids can be accumulated and managed properly. The central collection point should be determined in advance of liquids collection. Pipeline liquid may not be shipped from one hazardous waste generator site to another hazardous waste generator site.

**5. SAMPLING**

Pipeline liquids must be adequately characterized to assure proper classification and management. Typical laboratory characterization includes analysis for PCBs, metals, volatile organic compounds, ignitability or flashpoint, and reactive compounds. Once pipeline liquids at a given location have been adequately characterized, the routine analysis may be limited to fewer parameters, such as PCBs. It is the responsibility of the state environmental staff to coordinate with the laboratory for proper sample bottles, preservatives, and chain of custody forms.

Due to the potential for PCB contamination in pipeline liquids removed from the natural gas distribution system, pipeline liquids should be sampled for PCB content. The frequency of sampling should be based on a prudent evaluation of operating history, past sampling results, and reasonable expectation of whether or not PCBs are suspected to be present. The PCB concentration must be determined, at a minimum, prior to shipment of the liquid off-site.

The PCB concentration determines the co-product or waste status of the pipeline liquids. The PCB results should be expedited to assure that pipeline liquids are managed correctly and do not exceed the allowable time to be on site.

**6. ACCUMULATION**

The accumulated pipeline liquids are to be managed in accordance with the following.

**6.1 Results less than 2 ppm PCBs**

As of the date of the sample, the accumulated pipeline liquid is a co-product and is not a hazardous or PCB waste. To retain co-product status, the co-product cannot be mixed with wastes or cannot be placed in a drum that previously contained PCBs at 50 ppm or greater. There is no regulatory accumulation time for co-product.

**6.2 Results greater than 2ppm PCBs but less than 50 ppm PCBs**

The date of first accumulation for pipeline liquids with detectable PCBs is the date the liquid is placed into an empty container. If pipeline liquids with detectable PCBs are placed in a container with co-product, the date of first accumulation for the container becomes the first day the PCBs were added to the container. The container is then a hazardous waste container and must be managed in compliance with the applicable hazardous waste regulations.



**Distribution Operations**

**Health, Safety and Environmental Standard**

|                               |                                    |   |
|-------------------------------|------------------------------------|---|
| Effective Date:<br>11/01/2013 | <b>Pipeline Liquids Management</b> | Standard Number:<br><b>HSE 4400.050</b> |
| Supersedes:<br>N/A            |                                    | Page 4 of 9                             |

If pipeline liquids that are hazardous wastes and also have PCBs detected at less than 50 ppm PCBs are being collected in a satellite accumulation (SA) container, then the first date of accumulation is the date when the SA container is full. SA drums are applicable only to pipeline liquids that are hazardous waste and that contain less than 50 ppm PCBs.

**6.3 Results 50 ppm PCBs or Greater**

The date of first accumulation and out of service date for pipeline liquids with 50 ppm PCBs or greater is the date the liquid is placed into an empty container. If pipeline liquids containing 50 ppm PCBs or greater are placed in a container with co-product, the date of first accumulation and out of service date for the container is the first day the PCBs were added to the container. If pipeline liquids containing 50 ppm PCBs or greater are placed in a container accumulating hazardous waste, the date of first accumulation remains the first date that hazardous waste was placed in the container. The PCB out of service date for the container is the date that the 50 ppm PCBs or greater fluid was put into the container. The container is then a hazardous waste and a PCB waste container. The container must be managed in accordance with hazardous waste and PCB regulations.

**7. LABELING**

Containers used to collect, transport and/or store liquid should be labeled appropriately. Containers for which analysis is pending should be labeled "Analysis Pending". Containers of pipeline liquids should be labeled with appropriate hazard communication information. Containers for ignitable pipeline liquid shall be labeled "Flammable Liquids". If samples indicate pipeline liquids are hazardous waste, then a hazardous waste label must be put on the container. If pipeline liquids have tested at 50 ppm PCBs or greater, then the container must have a PCB Mark ML.

**8. LOCAL PRODUCTION FLUID**

Local production fluid should be sold as product-quality hydrocarbons or returned to the producer, per contract specifications. If local production fluid is disposed of, then it should be managed as a RCRA-exempt hazardous waste and sent to a facility authorized to receive such material. The drum should be labeled as "Local Production Fluid".

**9. CO-PRODUCT**

Pipeline liquid that is less than 2 ppm PCBs is a co-product and may be sold as product hydrocarbon. Such co-product is not hazardous waste if used as feedstock, raw material in manufacturing process or as a substitute product. If the liquid is not product quality (such as too much water, low BTU value, or high flashpoint), then it must be managed as a hazardous waste if it exhibits any hazardous waste characteristics. If the liquid is not product quality and does not exhibit hazardous waste characteristics (such as ignitability or toxicity), then it is managed as a solid waste.



**Distribution Operations**

**Health, Safety and Environmental Standard**

|                               |                                    |   |
|-------------------------------|------------------------------------|---|
| Effective Date:<br>11/01/2013 | <b>Pipeline Liquids Management</b> | Standard Number:<br><b>HSE 4400.050</b> |
| Supersedes:<br>N/A            |                                    | Page 5 of 9                             |

Co-product shall be managed as a valuable substance. It must be separated from any water phase and must be stored in containers in good condition that are properly labeled. Co-product must be managed in a manner that prevents spills. The container should be labeled as "Co-product Hydrocarbons". The water phase, if present, must be adequately characterized and managed properly.

**10. PIPELINE LIQUID CONTAINING LESS THAN 50 PPM PCBs, BUT GREATER THAN 2 PPM PCBs**

Pipeline liquid containing less than 50 ppm PCBs but greater than 2 ppm PCBs shall be placed in a UN approved container and shall not be put into a container that previously contained PCBs at 50 ppm or greater. The accumulated pipeline liquid is to be managed as a hazardous waste. A hazardous waste label shall be put on the container, along with the first date of accumulation. The accumulated hazardous waste must be shipped off-site for disposal within the authorized accumulation period for the generator site (90 days for Large Quantity Generators, or LQGs; and 180 days for Small Quantity Generators, or SQGs). The typical hazardous waste codes for pipeline liquids with greater than 2 ppm PCBs but less than 50 ppm PCBs are D001 for ignitability and D018 for benzene.

**11. PIPELINE LIQUID GREATER THAN 50 PPM PCBs**

Pipeline liquid removed from any company location with a history or routine generation of pipeline liquid containing greater than 50 ppm PCBs is not to be transported from the point of generation by NiSource without prior approval from the state environmental staff or SSC. This liquid is to be managed as a hazardous waste and PCB waste during transportation and on-site accumulation.

The containers used to accumulate pipeline liquid at 50 ppm PCBs or greater are to be labeled with a hazardous waste label, a PCB label, and a flammable liquid label (if required). The date of first accumulation also must be marked on the containers. The date of first accumulation as a hazardous waste is the date hazardous waste is first placed in the container. The PCB out of service date is the date liquid containing 50 ppm PCBs is first put into a container.

If known or presumed to be 50 ppm PCB or greater, then the liquid must be shipped off-site within 30 days of the PCB out of service start date or the hazardous waste first date of accumulation, whichever is earlier. The PCB regulations provide for temporary storage of PCBs for 30 days. If this is not feasible, then the state environmental staff or SSC should proceed with notifying US EPA of PCB waste activity. The PCB container then must be stored in full compliance with PCB regulations and must be shipped off-site for disposal based on the hazardous waste regulations (90 days from date of first accumulation for LQG and 180 days of first accumulation for SQG).

**12. DECONTAMINATION OF PCB CONTAINERS**

A container that was used to collect liquid containing 50 ppm or greater PCB should be disposed of as a PCB waste along with the liquid. If the container is not disposed of, it is a



**Distribution Operations**

**Health, Safety and Environmental Standard**

|                               |                                    |   |
|-------------------------------|------------------------------------|---|
| Effective Date:<br>11/01/2013 | <b>Pipeline Liquids Management</b> | Standard Number:<br><b>HSE 4400.050</b> |
| Supersedes:<br>N/A            |                                    | Page 6 of 9                             |

PCB article and should be labeled with the PCB mark. Any liquids placed in the container must be managed as a PCB and a hazardous waste if it also exhibits hazardous waste characteristics. If the container is to be reused for non- PCB wastes, then the drum should be decontaminated by flushing at least three times with kerosene or other suitable liquid as advised by the state environmental staff or SSC. Each rinse shall consist of a volume of rinseate equal to approximately ten percent of the container.

The rinseate must be disposed of as 50 ppm or greater PCB. An empty and decontaminated container should not be labeled with a hazardous waste or PCB label and should be marked as "Triple Rinsed".

**13. LOW PRESSURE WATER**

Water that is collected primarily from low pressure (and sometimes intermediate pressure) natural gas distribution pipeline systems is usually caused by the infiltration of water through leaks in water mains, flooding, or high groundwater situations. The water can pick up contaminants in the gas pipeline and must be characterized and tested to assure proper management.

NiSource personnel should collect as much low pressure water as possible from distribution mains, including 3-inch and above service lines. Collection equipment includes one (1) to 55 gallon containers, hand-operated or intrinsically safe pump, tapping tees, funnels, hose or piping, and/or fittings to direct water from tapping location into collection container.

The water should be placed into a single container and labeled "Low Pressure Water". The water should be transported back to the service center, placed into another collection container, if needed, where it can be either discharged to the city sanitary sewer or disposed of as wastewater.

The low pressure water must be adequately characterized to assure proper disposal. At least one sample from each separate system in each operating area should be taken at the time the water is collected. When first characterizing water from a low pressure system, analysis of the water should include the parameters required under the Resource Conservation and Recovery Act (RCRA) Toxicity Characteristic Leachate Procedure (TCLP) and PCBs. Subsequent analysis should include any constituents of concern present in the first round of sampling and any additional analysis required by the local publicly owned treatment works (POTW). Once the levels of constituents have been quantified through two to three rounds of sampling, only periodic sampling (such as once per year) should be needed. It is the responsibility of the state environmental staff, with guidance from SSC, to determine low pressure water sampling needs.

The preferred method of disposing of low pressure water is to obtain permission (preferably in writing) from the local POTW to discharge the water into the POTW's sanitary sewer system. If the POTW grants permission, the area should follow all instructions, guidelines and requirements of the POTW; and the area should document the discharge.

If the POTW does not authorize the discharge, then the low pressure water shall be



**Distribution Operations**

**Health, Safety and Environmental Standard**

|                               |                                    |   |
|-------------------------------|------------------------------------|---|
| Effective Date:<br>11/01/2013 | <b>Pipeline Liquids Management</b> | Standard Number:<br><b>HSE 4400.050</b> |
| Supersedes:<br>N/A            |                                    | Page 7 of 9                             |

disposed of at a commercial treatment facility that is licensed to accept such wastewater. The low pressure water may be a non-hazardous waste or a hazardous waste depending on its characteristics.

In the event of unusual conditions such as severe flooding where customer outages are widespread, the requirement to collect the water can be waived, but the environmental officer of the company (or his representative) shall be notified at the first opportunity.

A sample should be collected, if at all possible, to verify the concentration of the constituents present for possible reporting to regulatory agencies.

**14. RECORD KEEPING**

Records to document proper management of pipeline liquids are to be retained for at least three years. Records include laboratory analyses, hazardous waste manifests, PCB manifests, bills of sale for co-product, and operating records.



Distribution Operations

Health, Safety and Environmental Standard

|                               |                                    |   |
|-------------------------------|------------------------------------|---|
| Effective Date:<br>11/01/2013 | <b>Pipeline Liquids Management</b> | Standard Number:<br><b>HSE 4400.050</b> |
| Supersedes:<br>N/A            |                                    | Page 8 of 9                             |

**EXHIBIT A  
(1 of 2)**

Instructions for Completion of Form GS 5300.100-2  
 "Report of Liquid Found"

The following are keyed to Form GS 5300.100-2

| <u>Key</u> | <u>Item</u>   | <u>Description</u>   |
|------------|---|--|
| 1          | Company   | Self Explanatory   |
| 2          | <span style="border: 1px solid black; padding: 2px;">Cost Center</span> | Self Explanatory   |
| 3          | Report No.  | A sequential Report Number designated by each <span style="border: 1px solid black; padding: 2px;">Operating Center</span>   |
| 4          | Date  | Self Explanatory   |
| 5          | Location  | Location where liquid was removed.   |
| 6          | "Reg.-Meas. Station"  | Check appropriate box and provide station number, if appropriate.  |
| 7          | Date of Last Inspection   | Self Explanatory   |
| 8          | Location of Liquid Found  | Check appropriate box. Use additional column if liquid is found in more than one piece of equipment. If "other" is checked, explain under remarks.                             |
| 9          | Description of Liquid Removed   | Check appropriate box.   |
| 10         | Amount of Liquid Found  | Check appropriate box and furnish approximate volume.  |
| 11         | Source of Liquid if Known   | Check appropriate box.   |
| 12         | Transferred to Storage Container  | Check "yes," if liquid is drained into storage container from collection container. Give date of transfer.   |
| 13         | Location and ID Marking on Storage Container                            | Provide location and ID number of storage container from Form <span style="border: 1px solid black; padding: 2px;">GS 5300.100-3</span> "Pipeline Liquids - Disposal History." |
| 14         | Remarks   | Enter any additional information which may describe the origin and nature of the liquid removed and any problems noted when liquids were removed.                              |



Distribution Operations

Health, Safety and Environmental Standard

|                               |                                    |   |
|-------------------------------|------------------------------------|---|
| Effective Date:<br>11/01/2013 | <b>Pipeline Liquids Management</b> | Standard Number:<br><b>HSE 4400.050</b> |
| Supersedes:<br>N/A            |                                    | Page 9 of 9                             |

**EXHIBIT A**  
**(2 of 2)**

NiSource Distribution Operations

**REPORT OF LIQUID FOUND**

|  |  |  |  |                               |                |
|--|--|--|--|-------------------------------|----------------|
| COMPANY (1)  |  | <input type="checkbox"/> COH <input type="checkbox"/> CMA <input type="checkbox"/> CVA<br><input type="checkbox"/> CPA <input type="checkbox"/> CMD <input type="checkbox"/> CKY |  | Cost Center (2)               | REPORT NO. (3) |
| LOCATION (5)   |  |  |  | DATE (4)                      |                |
| <input type="checkbox"/> REG. STATION    NUMBER (6)<br><input type="checkbox"/> MEAS. STATION  |  | DATE OF LAST INSPECTION (MO/YR) (7)  |  |                               |                |
| LOCATION OF LIQUID FOUND (8)   | <input type="checkbox"/> METER <input type="checkbox"/> REG.<br><input type="checkbox"/> DRIP <input type="checkbox"/> OTHER*                  | <input type="checkbox"/> METER <input type="checkbox"/> REG.<br><input type="checkbox"/> DRIP <input type="checkbox"/> OTHER*  | <input type="checkbox"/> METER <input type="checkbox"/> REG.<br><input type="checkbox"/> DRIP <input type="checkbox"/> OTHER*                  |                               |                |
| DESCRIPTION OF LIQUID REMOVED (9)  | <input type="checkbox"/> WATER <input type="checkbox"/> HEAVY OIL<br><input type="checkbox"/> LIGHT OIL <input type="checkbox"/> OTHER*        | <input type="checkbox"/> WATER <input type="checkbox"/> HEAVY OIL<br><input type="checkbox"/> LIGHT OIL <input type="checkbox"/> OTHER*  | <input type="checkbox"/> WATER <input type="checkbox"/> HEAVY OIL<br><input type="checkbox"/> LIGHT OIL <input type="checkbox"/> OTHER*        |                               |                |
| AMOUNT OF LIQUID FOUND (10)  | <input type="checkbox"/> OZ _____ <input type="checkbox"/> QTS _____<br><input type="checkbox"/> PTS _____ <input type="checkbox"/> GALS _____ | <input type="checkbox"/> OZ _____ <input type="checkbox"/> QTS _____<br><input type="checkbox"/> PTS _____ <input type="checkbox"/> GALS _____                                   | <input type="checkbox"/> OZ _____ <input type="checkbox"/> QTS _____<br><input type="checkbox"/> PTS _____ <input type="checkbox"/> GALS _____ |                               |                |
| SOURCE OF LIQUID IF KNOWN (11)   | <input type="checkbox"/> LOC PROD <input type="checkbox"/> BKN MAIN<br><input type="checkbox"/> TRANS. CO. <input type="checkbox"/> OTHER*     | <input type="checkbox"/> LOC PROD <input type="checkbox"/> BKN MAIN<br><input type="checkbox"/> TRANS. CO. <input type="checkbox"/> OTHER*                                       | <input type="checkbox"/> LOC PROD <input type="checkbox"/> BKN MAIN<br><input type="checkbox"/> TRANS. CO. <input type="checkbox"/> OTHER*     |                               |                |
| TRANSFERRED TO STORAGE CONTAINER (12) <input type="checkbox"/> YES <input type="checkbox"/> NO |  |  |  | IF YES, GIVE DATE OF TRANSFER |                |
| LOCATION AND ID. MARKING ON STORAGE CONTAINER (13)   |  |  |  |                               |                |

\* REMARKS (ALSO BRIEFLY INDICATE EQUIPMENT DAMAGE AND CONDITION, INTERRUPTION OF SERVICE ETC, IF APPLICABLE) (14)

Form GS 5300.100-2





**Distribution Operations**

**Health, Safety and Environmental Standard**

|                               |                                  |  |
|-------------------------------|----------------------------------|--|
| Effective Date:<br>08/21/1995 | <b>Underground Storage Tanks</b> | Standard Number:<br><b>HSE 4400.060(CG)</b><br>P&P 580-4 |
| Supersedes:<br>N/A            |                                  | Page 1 of 19   |

Companies Affected:

|                                     |   |   |
|-------------------------------------|---|---|
| <input type="checkbox"/> NIPSCO     | <input checked="" type="checkbox"/> CGV | <input checked="" type="checkbox"/> CMD |
| <input type="checkbox"/> NIFL       | <input checked="" type="checkbox"/> CKY | <input checked="" type="checkbox"/> COH |
| <input type="checkbox"/> Kokomo Gas | <input type="checkbox"/> CMA            | <input checked="" type="checkbox"/> CPA |

**REFERENCE** Code of Federal Regulations - Title 40 - Part 280 and Comparative State Regulations.

**1. GENERAL**

In 1988, the United States Environmental Protection Agency (EPA) finalized regulations concerning the design and operation of Underground Storage Tanks (UST). This was a result of increasing evidence that many of the estimated 1.5 million underground tanks in the United States were leaking. The EPA determined that leaking tanks were threatening the nation's ground water supply as well as the general public.

**2. APPLICABILITY**

CDC currently owns and/or operates underground gasoline, diesel, and used oil tanks which fall under EPA regulations. This procedure establishes operating and maintenance requirements for those tanks. Installation of underground tanks which are to contain other substances shall be approved by the Environmental, Health and Safety Department since they are regulated differently. This procedure does not apply to propane or LNG stations.

**3. RESPONSIBILITY**

**3.1 Environmental Affairs Department**

The Environmental, Health and Safety Department is responsible for the following:

- a. Registration of the tanks with the appropriate state agencies.
- b. Answering requests for proof of financial responsibility from regulatory agencies in coordination with the Accounting, Tax and Risk Management Department; and
- c. The design and installation of:
  - 1. leak detection systems,
  - 2. spill and overfill controls, and
  - 3. cathodic protection systems.

*This document is considered CONTROLLED only when viewed electronically on the Company's intranet. Printed or other electronic copies may not be current, and the intranet version should be used to verify.*





**Distribution Operations**

**Health, Safety and Environmental Standard**

|                               |                                  |  |
|-------------------------------|----------------------------------|--|
| Effective Date:<br>08/21/1995 | <b>Underground Storage Tanks</b> | Standard Number:<br><b>HSE 4400.060(CG)</b><br>P&P 580-4 |
| Supersedes:<br>N/A            |                                  | Page 2 of 19   |

**3.2 District**

The District's responsibilities are to monitor the leak detection system and maintain the leak detection, spill and overfill controls, and cathodic protection systems.

**4. REGISTRATION**

Underground storage tanks containing petroleum fuels or used oil are subject to registration requirements. The Environmental, Health and Safety Department will coordinate the registration of UST's with the appropriate state agencies. See Exhibit A.

**5. FINANCIAL RESPONSIBILITY**

Requests for proof of financial responsibility from state agencies shall be forwarded to the Environmental, Health and Safety Department. The Environmental, Health and Safety Department in coordination with the Accounting, Tax and Risk Management Department will respond to the requests.

**6. EXISTING UNDERGROUND TANKS**

Existing UST's will be required to have the following modifications in order to continue operating:

- a. Leak Detection.
- b. Spill and Overfill Controls.
- c. Cathodic Protection (steel or steel composite tanks and piping only).

Section 7 lists the deadlines for when these modifications have to be made, or the tank(s) have to be removed or replaced.

**6.1 Leak Detection**

The requirement for leak detection may be satisfied using one of the following methods. For a summary of requirements, see Exhibit B.

**6.1.1 Automatic Tank Gauging**

Automatic tank gauging consists of a probe installed through an opening in the top of the tank. The probe continuously monitors the liquid level in the tank and corrects for changes in expansion or contraction due to temperature. The probe is connected to a control and alarm box which prints inventory reports. The probe can be programmed to conduct a leak test to detect leaks as small as 0.05 gallons per hour.



Distribution Operations

Health, Safety and Environmental Standard

|                               |                                  |  |
|-------------------------------|----------------------------------|--|
| Effective Date:<br>08/21/1995 | <b>Underground Storage Tanks</b> | Standard Number:<br><b>HSE 4400.060(CG)</b><br>P&P 580-4 |
| Supersedes:<br>N/A            |                                  | Page 3 of 19   |

**6.1.2 Vapor Monitoring**

In areas where ground water is not present at the tank location, wells may be installed around the tank(s) and piping. Probes installed in the well will detect hydrocarbon vapors and activate an alarm box.

**6.1.3 Ground Water Monitoring**

Ground water monitoring is similar to vapor monitoring, only the probes detect hydrocarbons which float on the ground water present in the well.

**6.1.4 Interstitial Monitoring**

In applications where double wall tanks and piping are present, probes are installed in the annular space between the walls of the tank and piping to detect hydrocarbon vapors. The probes are connected to an alarm box similar to vapor monitoring.

**6.1.5 Monthly Inventory Control Combined With Annual Tank Tightness Testing**

Monthly inventory control combined with an annual tank tightness test is acceptable until December 22, 1998. After December 22, 1998, one of the continuous leak detection methods identified in Sections 6.1.1, 6.1.2, 6.1.3 or 6.1.4, as well as spill and overfill controls per Section 6.2 will be required. It combines accurate daily measurement of inventory with annual testing of the tank and piping to provide assurance that no leaks are present. Annual Tank Tightness Tests shall be performed by a certified contractor.

Daily and monthly inventory control is required according to local procedures.

Note: Daily and monthly inventory control is also required for diesel fuel. In addition, each tank should be checked for water (to the nearest 1/8 inch) at least once a week. Inventory Control can be accomplished by using Forms C 1262-1, C 3109 and C 3110.

The monthly reconciliation shall be completed for each tank. If the monthly reconciliation indicates a discrepancy greater than 1% of the monthly usage plus 130 gallons, the Environmental, Health and Safety Department shall be notified.



**Distribution Operations**

**Health, Safety and Environmental Standard**

|                               |   |  |
|-------------------------------|---|--|
| Effective Date:<br>08/21/1995 | <h2 style="margin: 0;">Underground Storage Tanks</h2> | Standard Number:<br><b>HSE 4400.060(CG)</b><br>P&P 580-4 |
| Supersedes:<br>N/A            |   | Page 4 of 19   |

**6.1.6 Manual Tank Gauging**

Manual tank gauging may be used on underground tanks of 550 gallons or less and involves taking stick readings over a minimum 36 hour period of inactivity. For example, two stick readings would be taken on a Friday afternoon and two more taken on Monday morning. The additional stick reading is to ensure results which are reproducible. If an unexplained difference in stick readings occurs then another 36 hour test shall be taken immediately. If a leak is still indicated after the second test the Environmental, Health and Safety Department shall be notified. This method will continue to be acceptable after December 22, 1998 for underground tanks with capacities of 550 gallons or less.

These tests shall be performed weekly, with records being retained for three years on the following forms shown in Exhibit C:

- a. Form C 1262-1, "Daily Reconciliation of Gasoline and Oil Inventory."
- b. Form C 3109, "Product Balance Sheet."
- c. Form C 3110, "Daily Fuel Gain (Loss) Record."

**6.1.7 Monthly Inventory Control Combined With Tightness Testing Every Five Years**

This method can be used for UST systems which have overfill and spill controls and cathodic protection installed on the UST. Monthly inventory control is conducted as in Section 6.1.5. Tank testing is required the fifth and tenth year after installation. Tank testing is performed by a certified contractor. This method is not acceptable after December 22, 1998 for existing tanks. This method is not preferred for new tank installations which would be equipped with one of the continuous leakage detection methods per Sections 6.1.1, 6.1.2, 6.1.3 or 6.1.4, as well as spill and overfill controls per Section 6.2.

**6.2 Spill and Overfill Controls**

To prevent contamination at a tank location due to spills or overfills by the delivery service, spill and overfill controls will be required for all tanks. Spill and overfill controls shall be installed prior to December 22, 1998.

The items consist of:

- a. A catch basin installed around the fill pipe which drains overfills and spills into the tank; and either b. or c. See Exhibit D.
- b. An automatic shut off device such as a ball float valve, which engages when the tank is 95% full. This provides adequate tank volume to accept



**Distribution Operations**

**Health, Safety and Environmental Standard**

|                               |                                  |  |
|-------------------------------|----------------------------------|--|
| Effective Date:<br>08/21/1995 | <b>Underground Storage Tanks</b> | Standard Number:<br><b>HSE 4400.060(CG)</b><br>P&P 580-4 |
| Supersedes:<br>N/A            |                                  | Page 5 of 19   |

drainage from the fill hose prior to disconnecting.

- c. An alarm which sounds when the tank is 90% full.

**6.3 Cathodic Protection**

Metallic tanks and piping which are susceptible to corrosion shall be cathodically protected. The cathodic protection system shall be designed and installed by either a contractor approved by the Environmental, Health and Safety Department or Company personnel. In either case, the design of the cathodic protection system shall be approved by Engineering - Plant Operations.

To ensure an adequate level of cathodic protection, impressed current systems shall be monitored bi-monthly while other systems shall be monitored on an annual basis. Readings shall be recorded on Form C 1282-4, "Test Point Sheet" (Exhibit E) or documented in WMS as a Repetitive Task, if appropriate. The form shall be clearly marked to indicate it is an "Underground Storage Tank." See Exhibit E.

If testing indicates protection is deficient, the system shall be corrected to bring the protection to a level acceptable under [GS 1420.020](#) "Criteria for Cathodic Protection."

Existing tanks less than ten years old may have cathodic protection systems added provided that either:

- a. A leak detection system is installed per Sections 6.1.1, 6.1.2, 6.1.3, 6.1.4 or another continuous leak detection system meeting EPA's release detection requirement of 0.05 gallons per hour, or
- b. A tightness test is conducted prior to installation of the cathodic protection system and three to six months after the system is installed.

In addition to the requirements in a. and b. above, tanks which have been in service for a period longer than 10 years may be retrofitted with a cathodic protection system, provided the interior of the tank is inspected for corrosion prior to installation of the cathodic protection system.

**7. COMPLIANCE DEADLINES FOR EXISTING TANKS**

**7.1 Leak Detection**

All tanks, existing and new, must have leak detection systems in place.



**Distribution Operations**

**Health, Safety and Environmental Standard**

|                               |                                  |  |
|-------------------------------|----------------------------------|--|
| Effective Date:<br>08/21/1995 | <b>Underground Storage Tanks</b> | Standard Number:<br><b>HSE 4400.060(CG)</b><br>P&P 580-4 |
| Supersedes:<br>N/A            |                                  | Page 6 of 19   |

**7.2 Spill and Overfill Controls**

Spill and overfill controls shall be installed on all operating UST systems by December 22, 1998. The installation of the controls shall be initiated and coordinated by the Environmental, Health and Safety Department.

**7.3 Cathodic Protection**

A cathodic protection system shall be functioning for each UST system requiring cathodic protection under Section 6.3 by December 22, 1998.

**8. INSTALLATION OF UST SYSTEMS**

**8.1 Coordination**

The installation of and additions to underground storage tank systems shall be coordinated through the Environmental, Health and Safety Department. The Environmental, Health and Safety Department will:

- a. Coordinate the design and installation of UST systems with District personnel and with outside engineering consultants and contractors.
- b. Obtain permits.
- c. Register the tank within 30 days after the in-service date with the proper state agency.

**8.2 Documentation**

As part of the contract with the tank installer, the following documentation shall be required:

- a. Certification of the installer by the tank manufacturer.
- b. Permit or license as required from a state agency (Environmental Protection Agency, State Fire Marshal, etc.).
- c. Certification on the tank registration form that the UST system meets all requirements listed on page 3 of the notification form.
- d. A description, sketch, and materials list of the completed UST system installation (as-built drawing).
- e. Photographs of the UST system prior to backfilling.
- f. Tank warranty as supplied by the manufacturer.



**Distribution Operations**

**Health, Safety and Environmental Standard**

|                               |                                  |  |
|-------------------------------|----------------------------------|--|
| Effective Date:<br>08/21/1995 | <b>Underground Storage Tanks</b> | Standard Number:<br><b>HSE 4400.060(CG)</b><br>P&P 580-4 |
| Supersedes:<br>N/A            |                                  | Page 7 of 19   |

**9. REMOVAL OF EXISTING UST SYSTEMS**

The Environmental, Health and Safety Department shall coordinate with District personnel and with outside engineering consultants and contractors the details of UST system removals.

State and Federal regulations require that written notice to state agencies be given 30 days prior to the removal date.

In addition to excavation of the tank, the contractor shall:

- a. Render the tank useless by demolishing, cutting or otherwise punching holes in tank.
- b. Take a soil sample from an area at least 50' from the tank to use as a background sample and at least two soil samples from the excavation pit. Samples taken from the excavation pit shall be in areas where contamination would likely be found and where staining or other evidence of leakage is present.
- c. Contact the local fire department prior to excavation and obtain permit if necessary.
- d. Provide documentation of the ultimate disposal of the tank. A tank may be sold for scrap provided that it has been cleaned of product and sludge's.
- e. Follow any state requirements in addition to the above.

If evidence of leakage is found during the removal process, or by analysis of soil and/or ground water samples, the state agency shall be notified within 24 hours of determination. The notification procedure is given in Section 11.

**10. CLOSURE OF EXISTING UST SYSTEMS**

After obtaining approval from the appropriate state agencies, tanks that are to be permanently closed and left in place shall be emptied and cleansed of previous contents. Then it shall be filled with inert solid material.

**11. NOTIFICATION PROCEDURE FOR SUSPECTED LEAKS**

When a leak from a UST system is discovered or suspected, notice shall be given immediately to the Environmental, Health and Safety Department in accordance with [HSE 4400.020\(CG\)](#) "Environmental Occurrence Reporting."

The Environmental, Health and Safety Department or Law Department will make the required notice to the appropriate state agency. Notice is required to the appropriate state agency within 24 hours with additional follow up and reporting deadlines at 20 and 40 days.



**Distribution Operations**

**Health, Safety and Environmental Standard**

|                               |                                  |  |
|-------------------------------|----------------------------------|--|
| Effective Date:<br>08/21/1995 | <b>Underground Storage Tanks</b> | Standard Number:<br><b>HSE 4400.060(CG)</b><br>P&P 580-4 |
| Supersedes:<br>N/A            |                                  | Page 8 of 19   |

**12. OTHER NOTIFICATIONS**

All proposed modifications or changes in the UST system or the products contained in the UST system shall require approval from the Environmental, Health and Safety Department.

Any petroleum odors, fumes or other occurrences which may be the result of contamination from an underground tank previously closed or removed shall be reported to the Environmental, Health and Safety Department in accordance with [HSE 4400.020\(CG\)](#) "Environmental Occurrence Reporting."

**13. CONTAMINATION COMPLIANCE**

If it has been determined that a release from a UST system has contaminated the surrounding soil and/or ground water, the Environmental, Health and Safety Department will pre-scribe the remedial procedure for remediation as required by state regulations.



Health, Safety and Environmental Standard

|                               |                                    |  |
|-------------------------------|------------------------------------|--|
| Effective Date:<br>08/21/1995 | <h1>Underground Storage Tanks</h1> | Standard Number:<br><b>HSE 4400.060(CG)</b><br>P&P 580-4 |
| Supersedes:<br>N/A            |                                    | Page 9 of 19   |

**EXHIBIT A  
(1 OF 2)**

| SUMMARY OF STATE UST PROGRAMS   |   |   |  |   |                |  |   |   |  |
|---|---|---|--|---|----------------|--|---|---|--|
| State   | State of UST Regulations  | Highlights of Technical Requirements that Differ from Federal   | Leaking of Certification Program   | Notification, Permit and Fees                             | Test/Pass/Fail | Cleanup Requirements   | Closure Requirements  | Comments  |  |
| Kentucky Division of Waste Management, Underground Storage Tank Branch, Franklin, KY 502-364-6726   | State adopted regulations that incorporate federal requirements in 1290 | None  | UST installer, repairer and others must be certified by state  | State verification form - \$30 tank annual fee            | Yes            | State submitted to conduct site-by-site groundwater, soil and site evaluations | Notification must be filed 30 days prior to closure. Soil analysis must be performed at all closure sites | Leak repairs to comply with provisions in addition to state requirements                |  |
| Maryland Department of Environment, Hazardous & Solid Waste Management Administration, Underground Storage Tank Program, Baltimore, MD 410-631-3443 | State regulations similar to federal rule were adopted 2461             | Test/leak testing with secondary protection required for all UST systems. Heating oil tanks are regulated | Install and repair certification program. State certifies tank testing methods                             | State verification form                                   | No             | None   | None  | Tank upgrade/repair program established   |  |
| Ohio Department of Commerce, Reynoldsburg OH 614-752-7928   | UST program is being developed for federal approval                     | Daily inventory control required. Records on out-of-service tanks must be kept on file                    | Effective 1/2000, installers must be certified by State. Maryland State is developing verification program | State verification form. Permit required for tank closure | Yes            | None   | Permit from State. Pre-Mandatory for closure. State assessment also required                              | State assists small business in locating banks for purchase. Most locations require UST |  |





Health, Safety and Environmental Standard

|                               |                                    |  |
|-------------------------------|------------------------------------|--|
| Effective Date:<br>08/21/1995 | <h1>Underground Storage Tanks</h1> | Standard Number:<br><b>HSE 4400.060(CG)</b><br>P&P 580-4 |
| Supersedes:<br>N/A            |                                    | Page 10 of 19  |

**EXHIBIT A  
(2 OF 2)**

SUMMARY OF STATE UST PROGRAMS

| State  | State of UST Regulations  | Highlights of Technical Requirements that Differ from Federal   | Licensing of Contractors Program (Y)                 | Notification Permits and Fees  | Test Puff (Y) | Cleanup Requirements                      | Cleanup Requirements  | Comments  |
|--|---|---|--|--|---------------|---|---|---|
| Pennsylvania<br>Department of Environmental Resources, Storage Tank Program, ERQC, Harrisburg, PA 217-637-5128 | SP 280 enacted establishing storage tank program. Regulations are being drafted.                | Application for site approval and plan must be submitted to Fire Marshal.   | Certification program for installers and inspectors. | Registration of regulated tanks required. Annual registration fees: UST: \$30 each, AST: \$30-\$300 each. Need permit from Fire Marshal for installation and removal of tanks. This will change over to EPC. | Yes           | None                                      | Advanced and permit from Fire Marshal required for removal.   | State has established small UST and AST facility program administered by the Department of Commerce. Alligbery and Philadelphia courses for technicians. ASTs are regulated.                          |
| Virginia State Water Control Board, Richmond, VA, 804-527-5120   | UST technical rule waiting to effect. October 1989 and miscellaneous regulatory rules May 1990. | Having tanks greater than 5,000 gallons in regulated. Permit required for cleanup plan. Notification required for UST out of service before 1994. | None   | EPAs notification form.  | Yes           | Permit needed for corrective action plan. | Cleanup assessment and soil samples required. Notification required for UST out of service before 10/94 if remains in ground. | Local building officials issue permit to install, upgrade, repair and close. USTs under NPS, 30 and state building code. Building code references state UST rules. Monitoring wells required by 5/92. |



**Distribution Operations**

**Health, Safety and Environmental Standard**

|                               |                                  |  |
|-------------------------------|----------------------------------|--|
| Effective Date:<br>08/21/1995 | <b>Underground Storage Tanks</b> | Standard Number:<br><b>HSE 4400.060(CG)</b><br>P&P 580-4 |
| Supersedes:<br>N/A            |                                  | Page 11 of 19  |

**EXHIBIT B**

**SUMMARY OF REQUIREMENTS FOR RELEASE DETECTION**

**MINIMUM REQUIREMENTS**

| Type of Tank or Piping   | Release Detection Method   |       |       |                           |                     |  |  |                         |  |
|--|--|-------|-------|---------------------------|---------------------|--|--|-------------------------|--|
| New Tanks<br><br>1 Choice  | Monthly Monitoring (1)   |       |       |                           |                     |  |  |                         |  |
| Existing Tanks<br><br>3 Choices  | Monthly Monitoring (1)<br>Monthly Inventory Control and Annual Tank Tightness Testing (2)<br>Monthly Inventory Control and Tank Tightness Testing Every 5 Years (3)  |       |       |                           |                     |  |  |                         |  |
| New and Existing Pressurized Piping<br><br>Choice of one from each set | <table style="width: 100%; border: none;"> <tr> <td style="text-align: center;">Set 1</td> <td style="text-align: center;">Set 2</td> </tr> <tr> <td>Automatic Flow Restrictor</td> <td>Annual Line Testing</td> </tr> <tr> <td colspan="2">Automatic Shutoff Device - <u>and</u> - Monthly Monitoring (4)</td> </tr> <tr> <td colspan="2">Continuous Alarm System</td> </tr> </table> | Set 1 | Set 2 | Automatic Flow Restrictor | Annual Line Testing | Automatic Shutoff Device - <u>and</u> - Monthly Monitoring (4) |  | Continuous Alarm System |  |
| Set 1  | Set 2  |       |       |                           |                     |  |  |                         |  |
| Automatic Flow Restrictor  | Annual Line Testing  |       |       |                           |                     |  |  |                         |  |
| Automatic Shutoff Device - <u>and</u> - Monthly Monitoring (4)         |  |       |       |                           |                     |  |  |                         |  |
| Continuous Alarm System  |  |       |       |                           |                     |  |  |                         |  |
| New and Existing Suction Piping  | Monthly Monitoring (4)<br>Line Testing Every 3 Years   |       |       |                           |                     |  |  |                         |  |

- (1) Includes: Automatic Tank Gauging, Vapor Monitoring, Interstitial Monitoring, Ground Water Monitoring.
- (2) Can be used only until December 1998.
- (3) Can be used only for ten years after adding corrosion protection and spill/overflow prevention or until December 1998, whichever is later.
- (4) Same as (1) except automatic tank gauging.



**Health, Safety and Environmental Standard**

|                               |                                    |  |
|-------------------------------|------------------------------------|--|
| Effective Date:<br>08/21/1995 | <h2>Underground Storage Tanks</h2> | Standard Number:<br><b>HSE 4400.060(CG)</b><br>P&P 580-4 |
| Supersedes:<br>N/A            |                                    | Page 12 of 19  |

**EXHIBIT C  
(1 OF 6)**

**FRONT OF FORM**

FORM C 1262-1 CPS (8-94)

COLUMBIA GAS DISTRIBUTION COMPANIES  
**DAILY RECONCILIATION OF GASOLINE & DIESEL**  
(with oil & water reconciliation)

COMPANY \_\_\_\_\_ NO. \_\_\_\_\_

LOCATION \_\_\_\_\_ LOC. NO. \_\_\_\_\_ DATE \_\_\_\_\_, 19\_\_

**TANK # 1**      **PRODUCT** \_\_\_\_\_

|               |          |          |
|---------------|----------|----------|
|               | PUMP # 1 | PUMP # 2 |
| ENDING        |          |          |
| BEGINNING     |          |          |
| ISSUED        |          |          |
|               | PUMP # 3 | PUMP # 4 |
| ENDING        |          |          |
| BEGINNING     |          |          |
| ISSUED        |          |          |
|               | INCHES   | GALLONS  |
| STICK READING |          |          |
| ON HAND       |          |          |

|   |  |
|---|--|
| BEGINNING BALANCE                           |  |
| RECEIVED                                    |  |
|   |  |
|   |  |
| <b>TOTAL TO ACCOUNT FOR</b>                 |  |
| TOTAL ISSUED                                |  |
| GALLONS ON HAND                             |  |
|   |  |
| TOTAL ACCOUNTED FOR                         |  |
| LOSS OR GAIN TODAY                          |  |
| LOSS OR GAIN CARRIED OVER FROM PREVIOUS DAY |  |
| NET LOSS OR GAIN TO DATE                    |  |

RECONCILED BY \_\_\_\_\_

**TANK # 2**      **PRODUCT** \_\_\_\_\_

|               |          |          |
|---------------|----------|----------|
|               | PUMP # 1 | PUMP # 2 |
| ENDING        |          |          |
| BEGINNING     |          |          |
| ISSUED        |          |          |
|               | PUMP # 3 | PUMP # 4 |
| ENDING        |          |          |
| BEGINNING     |          |          |
| ISSUED        |          |          |
|               | INCHES   | GALLONS  |
| STICK READING |          |          |
| ON HAND       |          |          |

|   |  |
|---|--|
| BEGINNING BALANCE                           |  |
| RECEIVED                                    |  |
|   |  |
|   |  |
| <b>TOTAL TO ACCOUNT FOR</b>                 |  |
| TOTAL ISSUED                                |  |
| GALLONS ON HAND                             |  |
|   |  |
| TOTAL ACCOUNTED FOR                         |  |
| LOSS OR GAIN TODAY                          |  |
| LOSS OR GAIN CARRIED OVER FROM PREVIOUS DAY |  |
| NET LOSS OR GAIN TO DATE                    |  |

RECONCILED BY \_\_\_\_\_



**Health, Safety and Environmental Standard**

|                               |                                    |  |
|-------------------------------|------------------------------------|--|
| Effective Date:<br>08/21/1995 | <h1>Underground Storage Tanks</h1> | Standard Number:<br><b>HSE 4400.060(CG)</b><br>P&P 580-4 |
| Supersedes:<br>N/A            |                                    | Page 13 of 19  |

**EXHIBIT C  
(2 OF 6)**

**BACK OF FORM**

**TANK # 3      PRODUCT \_\_\_\_\_**

|               | PUMP # 1 | PUMP # 2 |  |
|---------------|----------|----------|--|
| ENDING        |          |          |  |
| BEGINNING     |          |          |  |
| ISSUED        |          |          |  |
|               | PUMP # 3 | PUMP # 4 |  |
| ENDING        |          |          |  |
| BEGINNING     |          |          |  |
| ISSUED        |          |          |  |
|               | INCHES   | GALLONS  |  |
| STICK READING |          |          |  |
| ON HAND       |          |          |  |

|   |  |
|---|--|
| BEGINNING BALANCE                           |  |
| RECEIVED                                    |  |
|   |  |
| TOTAL TO ACCOUNT FOR                        |  |
| TOTAL ISSUED                                |  |
| GALLONS ON HAND                             |  |
|   |  |
| TOTAL ACCOUNTED FOR                         |  |
| LOSS OR GAIN TODAY                          |  |
| LOSS OR GAIN CARRIED OVER FROM PREVIOUS DAY |  |
| NET LOSS OR GAIN TO DATE                    |  |

RECONCILED BY \_\_\_\_\_

**TANK # 4      PRODUCT \_\_\_\_\_**

|               | PUMP # 1 | PUMP # 2 |  |
|---------------|----------|----------|--|
| ENDING        |          |          |  |
| BEGINNING     |          |          |  |
| ISSUED        |          |          |  |
|               | PUMP # 3 | PUMP # 4 |  |
| ENDING        |          |          |  |
| BEGINNING     |          |          |  |
| ISSUED        |          |          |  |
|               | INCHES   | GALLONS  |  |
| STICK READING |          |          |  |
| ON HAND       |          |          |  |

|   |  |
|---|--|
| BEGINNING BALANCE                           |  |
| RECEIVED                                    |  |
|   |  |
| TOTAL TO ACCOUNT FOR                        |  |
| TOTAL ISSUED                                |  |
| GALLONS ON HAND                             |  |
|   |  |
| TOTAL ACCOUNTED FOR                         |  |
| LOSS OR GAIN TODAY                          |  |
| LOSS OR GAIN CARRIED OVER FROM PREVIOUS DAY |  |
| NET LOSS OR GAIN TO DATE                    |  |

RECONCILED BY \_\_\_\_\_

**RECONCILIATION OF MOTOR OIL**

|                      |  |
|----------------------|--|
| BEGINNING BALANCE    |  |
| RECEIVED             |  |
| TOTAL TO ACCOUNT FOR |  |
|                      |  |
| TOTAL ISSUED         |  |
| QTS. OF OIL ON HAND  |  |
| TOTAL ACCOUNTED FOR  |  |

**WATER LEVEL (to nearest 1/8 inch)**

| TANK | DATE | LEVEL |
|------|------|-------|
| #1   |      |       |
| #2   |      |       |
| #3   |      |       |
| #4   |      |       |





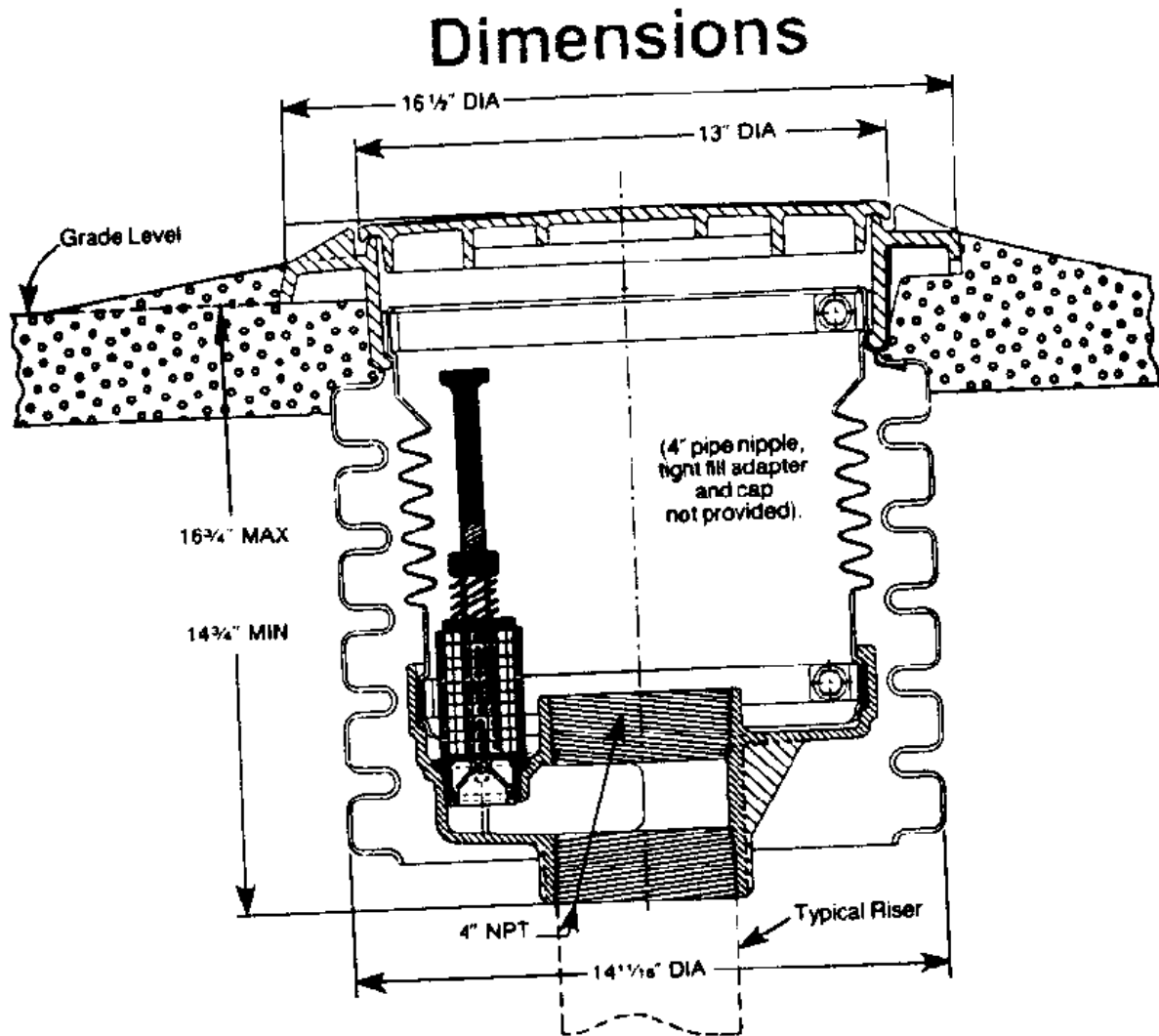






|                               |                                  |  |
|-------------------------------|----------------------------------|--|
| Effective Date:<br>08/21/1995 | <b>Underground Storage Tanks</b> | Standard Number:<br><b>HSE 4400.060(CG)</b><br>P&P 580-4 |
| Supersedes:<br>N/A            |                                  | Page 18 of 19  |

**EXHIBIT D**







## Health, Safety and Environmental Standard

### Distribution Operations

|                               |                                  |   |
|-------------------------------|----------------------------------|---|
| Effective Date:<br>01/07/2015 | <b>PCB Sampling and Analysis</b> | Standard Number:<br><b>HSE 4400.070</b> |
| Supersedes:<br>N/A            |                                  | Page 1 of 6                             |

Companies Affected:

|                                 |   |   |
|---------------------------------|---|---|
| <input type="checkbox"/> NIPSCO | <input checked="" type="checkbox"/> CGV | <input checked="" type="checkbox"/> CMD |
|                                 | <input checked="" type="checkbox"/> CKY | <input checked="" type="checkbox"/> COH |
|                                 | <input checked="" type="checkbox"/> CMA | <input checked="" type="checkbox"/> CPA |

**REFERENCE** 40 CFR 761

### 1. GENERAL

This standard shall apply to sampling pipeline equipment and associated media for PCB (polychlorinated biphenyl) in portions of NiSource natural gas distribution system.

### 2. APPLICABILITY

This standard applies to portions of the NiSource Gas Distribution systems that are potentially PCB-impacted and equipment and waste that is potentially contaminated with PCBs. The number and type of samples is specific to each application.

Where PCBs are known or suspected to be present, sampling shall be necessary to:

- a. profile waste for disposal,
- b. characterize the surrounding system to determine what regulations may apply,
- c. determine how to manage removed or abandoned pipe and other ancillary equipment, and/or
- d. for assessment and confirmation sampling during cleanup of a spill.

Different sampling methods and media may be involved.

Sampling methods commonly used for PCB include the following.

- a. **Wipe sampling** – Used to determine the levels of PCB remaining on surfaces; used to determine what abandonment or disposal methods are available, or to determine if decontamination is needed or has been successful.
- b. **Liquid Sampling** – Used to profile pipeline condensate for disposal or sale, and to determine regulatory status of surrounding natural gas distribution system.

### 3. TYPES OF ANALYSIS

Laboratory analysis of samples should be reported as Aroclors. Laboratories should be instructed to analyze samples for the seven standard Aroclors (1016, 1221, 1232, 1242,

*This document is considered CONTROLLED only when viewed electronically on the Company's intranet. Printed or other electronic copies may not be current, and the intranet version should be used to verify.*



## Health, Safety and Environmental Standard

### Distribution Operations

|                               |                                  |   |
|-------------------------------|----------------------------------|---|
| Effective Date:<br>01/07/2015 | <b>PCB Sampling and Analysis</b> | Standard Number:<br><b>HSE 4400.070</b> |
| Supersedes:<br>N/A            |                                  | Page 2 of 6                             |

1248, 1254, and 1260), plus Aroclors 1262 (building products) and 1268 (valve grease).

#### 4. WIPE SAMPLING:

Wipe samples shall be collected as follows.

- a. During retirement projects of mainline pipe greater than four inches in diameter.
- b. From first joint and the last joint if available during abandonment or removal of pipe greater than four (4) inch nominal pipe diameter so that an average of the sample results can be calculated.

Wipe sampling must be conducted in accordance with EPA's standard wipe sampling requirements (see below):

- a. Wipe samples are extracted and analyzed by the laboratory using EPA Method 8082.
- b. Results are reported as ug/sample. In order to be compared with EPA standards, the result must then be divided by the area sampled, which shall be 100 cm<sup>2</sup>.

The Laboratory Sample instructions shall be followed when collecting wipe samples from pipe using a wipe template supplied by the laboratory. In addition the following steps shall also be completed.

1. Label each sample bottle with the job order number. If more than one sample is being collected under the same job order, number the samples sequentially. For example:
  - a. Job Order 13-0177412-00-01
  - b. Job Order 13-0177412-00-02
2. Place all disposable sampling material such as templates and gloves in the pipe segments being removed and cap each end of the pipe and label it with the job order number. Store the pipe on a secured company facility. Pipe is assumed to be non-contaminated until laboratory results are received. Upon receipt of lab results proper disposal will be determined by HSE.

#### 5. HYDROCARBON LIQUID SAMPLING

- a. Representative hydrocarbon liquid samples are required whenever liquids are initially found in a distribution facility. A facility is defined as: mains, service lines, meters, regulators, drips, filters, or any other equipment connected to the distribution system where liquids could collect.
- b. Liquids shall be placed in separate containers, labeled with the job order number,



## Health, Safety and Environmental Standard

### Distribution Operations

|                               |                                  |   |
|-------------------------------|----------------------------------|---|
| Effective Date:<br>01/07/2015 | <b>PCB Sampling and Analysis</b> | Standard Number:<br><b>HSE 4400.070</b> |
| Supersedes:<br>N/A            |                                  | Page 3 of 6                             |

and marked as "Pending Analysis."

- c. Upon receipt of laboratory results, liquids can be properly labeled, stored, and shipped for disposal. HSE shall determine disposal method.

The following steps shall be followed when collecting liquid samples.

1. Liquids shall be drained as completely as practical into a collection container so that any subsequent sampling will be representative of the next period of collection.
2. Let the collection container stand open to atmosphere for at least 15 minutes to allow any entrapped gas to escape and to permit liquids (such as oils and water) to separate.
3. If solids are present throughout the liquid, it will be necessary to agitate the contents prior to sampling in order to obtain a representative sample.
4. Using a disposable pipette, syringe or other sampling device, fill a small glass bottle with at least 1 fluid ounce of oil sample (not water). The cap of the bottle shall either be teflon lined or aluminum foil used between the cap and the bottle.
5. To avoid cross contamination of samples the sampling device shall not be reused unless a second sample is taken for quality assurance. Care shall be taken to insure that the outside of the glass bottles and caps are not contaminated.
6. Tightly secure cap of sample container, seal with tape and then place inside of a plastic zip lock type bag. Place the plastic bag(s) into a second zip lock bag. The zip lock bag shall be packed inside of a cardboard box with shipping material to prevent breakage. Special labeling is not required as long as the amount of liquid per package does not exceed 16 fluid ounces.
7. Complete the chain of custody form and ship to laboratory (see Exhibit B.) Place all disposable sampling material such as pipettes, syringes and gloves in a sealed plastic bag and label it with the job order number. Store the bag in a dry secure location. Upon receipt of lab results proper disposal will be determined. Contact HSE for assistance.

## 6. WATER SAMPLING

The same procedures used to collect hydrocarbon liquid samples (see Section 5) must be used as applicable for collecting water samples.

Analysis should include any constituents required by the disposal vendor. Contact HSE for assistance.



## Health, Safety and Environmental Standard

### *Distribution Operations*

|                               |                                  |   |
|-------------------------------|----------------------------------|---|
| Effective Date:<br>01/07/2015 | <b>PCB Sampling and Analysis</b> | Standard Number:<br><b>HSE 4400.070</b> |
| Supersedes:<br>N/A            |                                  | Page 4 of 6                             |

### **7. SOIL AND CONCRETE SAMPLING**

In the event of a spill or release that requires samples to be collected from soil, concrete, or other media contact HSE for assistance as well as applicable response activities including agency notification (if necessary).



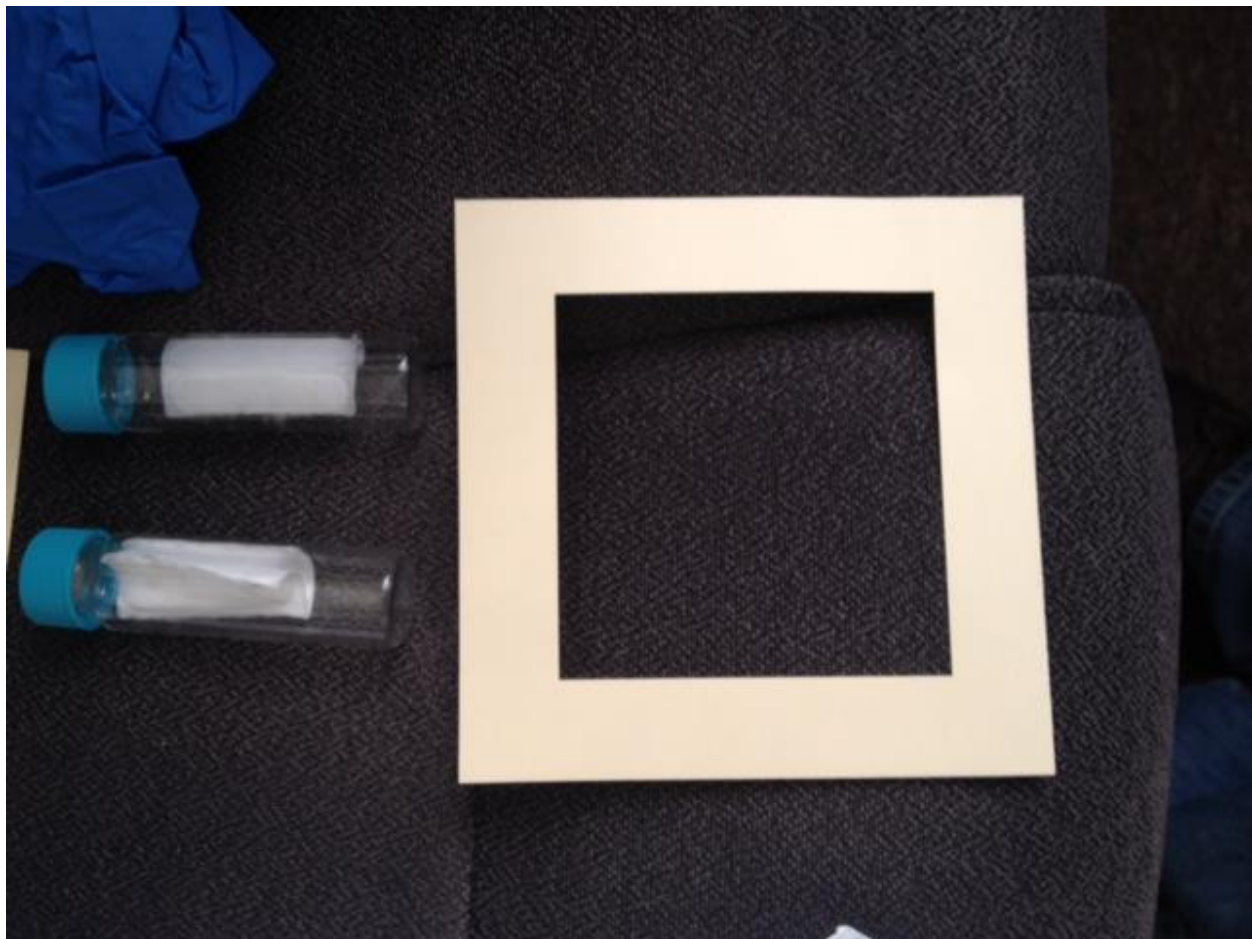
## Health, Safety and Environmental Standard

### Distribution Operations

|                               |                                  |   |
|-------------------------------|----------------------------------|---|
| Effective Date:<br>01/07/2015 | <b>PCB Sampling and Analysis</b> | Standard Number:<br><b>HSE 4400.070</b> |
| Supersedes:<br>N/A            |                                  | Page 5 of 6                             |

### EXHIBIT A

#### WIPE SAMPLE TEMPLATE AND SAMPLE BOTTLES











## Health, Safety and Environmental Standard

### Distribution Operations

|                               |                            |   |
|-------------------------------|----------------------------|---|
| Effective Date:<br>01/07/2015 | <b>PCB Data Management</b> | Standard Number:<br><b>HSE 4400.075</b> |
| Supersedes:<br>N/A            |                            | Page 1 of 5                             |

Companies Affected:

|                                 |   |   |
|---------------------------------|---|---|
| <input type="checkbox"/> NIPSCO | <input checked="" type="checkbox"/> CGV | <input checked="" type="checkbox"/> CMD |
|                                 | <input checked="" type="checkbox"/> CKY | <input checked="" type="checkbox"/> COH |
|                                 | <input checked="" type="checkbox"/> CMA | <input checked="" type="checkbox"/> CPA |

**REFERENCE** 40 CFR 761

### 1. GENERAL

This standard shall apply to the management of PCB sample information, including analytical results, locations, and Job Orders. All data shall be stored in the Work Management System (WMS.)

### 2. APPLICABILITY

This standard applies to PCB samples collected from within the NiSource Distribution Operations system, regardless of whether the location is within a known PCB-impacted area or not. Consult other guidance (specifically HSE 4400.070) for the specific sampling requirements.

### 3. TYPES OF SAMPLES AND SAMPLE CODING

Sampling methods commonly used for PCB include the following (sample coding abbreviations are shown in parentheses):

- a. **Wipe sampling** (WI)– Used to determine the levels of PCB remaining on surfaces; used to determine what abandonment or disposal methods are available, or to determine if decontamination is needed or has been successful;
- b. **Liquid sampling** (LI) –Used to profile pipeline condensate for disposal or sale, and to determine regulatory status of surrounding natural gas distribution system.

The detailed sampling procedures and associated analytical methods are described in HSE 4400.070 “PCB Sampling and Analysis.”

### 4. ENTERING PCB SAMPLE INFORMATION INTO WORK MANAGEMENT

The following steps shall be completed.

1. Log into the Work Management System – Red Mainframe. You should see “Network Services Sign-On Menu.”
2. Select “G” – CDC CICS Work Management Prod.

*This document is considered CONTROLLED only when viewed electronically on the Company's intranet. Printed or other electronic copies may not be current, and the intranet version should be used to verify.*



## Health, Safety and Environmental Standard

### Distribution Operations

|                               |                            |   |
|-------------------------------|----------------------------|---|
| Effective Date:<br>01/07/2015 | <b>PCB Data Management</b> | Standard Number:<br><b>HSE 4400.075</b> |
| Supersedes:<br>N/A            |                            | Page 2 of 5                             |

3. Enter your network USERID and PASSWORD. You will see that you successfully signed on to CICS.
4. Enter WMS0 (zero). You should see Work Management Main Menu.
5. From the Main Menu enter 2 in selection to enter the Job Order Menu.
6. From the Menu enter 3 (Job Order Execute).
7. From the Job Order Execute menu, enter your Job Order number. This will show you the Job Order Execute – Summary.
8. Select 5 (Pipe Exposure / Environmental Sample). This will show you Job Order Execute – Pipe Env / Env Sample Selection.
9. Select PF22 – Add Env Sample (Shift F10). This will show you Environmental Sample (Create) – Detail.
10. From the Detail screen, enter the PCB Sample information (see Exhibit A for example):
  - a. Sequential number of sample from job order (see “sampling and analysis” standard.)
  - b. Sample Type (Use Sample Coding from Section 3). To add additional details about the sample type conducted, select PF 10 and describe in Comments section.
  - c. Sample Date.
  - d. Lab sent to.
  - e. Pipe Size.
  - f. Comments.
  - g. Press Enter to enter the PCB Comments.
  - h. Press Enter again to record the information.

### 5. ENTERING PCB SAMPLE RESULTS INTO WORK MANAGEMENT

The laboratory results shall be entered into WMS.

1. Go to the Job Order execute screen (EJO) in Work Management (108 – Job # (Abandon #).
2. Enter job Order number.
3. At Job Order execute Summary Screen, enter 5 for pipeline exposure /



## Health, Safety and Environmental Standard

### *Distribution Operations*

|                               |                            |   |
|-------------------------------|----------------------------|---|
| Effective Date:<br>01/07/2015 | <b>PCB Data Management</b> | Standard Number:<br><b>HSE 4400.075</b> |
| Supersedes:<br>N/A            |                            | Page 3 of 5                             |

environmental sample.

4. Scroll to the appropriate sample number and select PF23 (shift F11) to update existing sample.
5. Go down to PCB CCT line and enter in the number (unitless) corresponding to the sample result. If the result was non-detect (ND), enter 0. Tab over to units and press F4, select the appropriate unit (see Exhibit B.)
6. Go down to the next line to Raw Results and follow the same procedure, including units.
7. If there are any comments on the chain of custody form (such as address or road intersection) press PF10 and enter information under PC Comments section.
8. Press Enter to enter the PCB Comments.
9. Press Enter again to record the information.



### Health, Safety and Environmental Standard

#### Distribution Operations

|                               |                            |   |
|-------------------------------|----------------------------|---|
| Effective Date:<br>01/07/2015 | <b>PCB Data Management</b> | Standard Number:<br><b>HSE 4400.075</b> |
| Supersedes:<br>N/A            |                            | Page 4 of 5                             |

### EXHIBIT A

```
T746 ENVIRONMENTAL SAMPLE (CREATE) - DETAIL 11/15/13
JO NO: 13-0177412-00 *JOB TYPE: 558 *LOC NO: 1721 SYS NO: 34299007
----- PCB INFORMATION -----
SAMPLE NO: 01 *SAMPLE TYPE: WI SAMPLE DATE: 11/15/13
LAB SENT TO: Trinity GPS:
TRACKING NO: *PIPE SIZE: 050
PSID NO: *EQUIP TYPE:
EST LIQ VOL: *UNIT: DISPOSAL CO:
PCB CCT: *UNIT: DISPOSAL DATE:
RAW RESULT: *UNIT: CERTIFICATE:
NORM RESULT: UG/100 SCM
SAMPLE REQUIRED: *FOLLOWUP CODE: ENTERED BY: U123937
SAMPLE TAKEN: *SYSTEM CHAR: ENTERED DATE: 11/15/2013
NEXT: DATA:
PF10-PCB COMMENTS PF13-JOB INQUIRY
```



### Health, Safety and Environmental Standard

#### Distribution Operations

|                               |                            |   |
|-------------------------------|----------------------------|---|
| Effective Date:<br>01/07/2015 | <b>PCB Data Management</b> | Standard Number:<br><b>HSE 4400.075</b> |
| Supersedes:<br>N/A            |                            | Page 5 of 5                             |

### EXHIBIT B

```
T746 ENVIRONMENTAL SAMPLE (UPDATE) - DETAIL 11/15/13
JO NO: 13-0177412-00 *JOB TYPE: 558 *LOC NO: 1721 SYS NO: 34299007
----- PCB INFORMATION -----
SAMPLE NO: 05 *SAMPLE TYPE: WI SAMPLE DATE: 10/21/2013
LAB SENT TO: TRINITY LAB GPS:
TRACKING NO: 3103010-01 *PIPE SIZE: 060
PSID NO: *EQUIP TYPE: MN
EST LIQ VOL: *UNIT: DISPOSAL CO:
PCB CCT: 1.80 *UNIT: UG/100 SCM DISPOSAL DATE:
RAW RESULT: 1.80 *UNIT: UG/100 SCM CERTIFICATE:
NORM RESULT: UG/100 SCM
SAMPLE REQUIRED: *FOLLOWUP CODE: ENTERED BY: U124966
SAMPLE TAKEN: *SYSTEM CHAR: GREEN ENTERED DATE: 11/06/2013
NEXT: DATA:
PF10-PCB COMMENTS PF13-JOB INQUIRY
```



**Distribution Operations**

**Health, Safety and Environmental Standard**

|   |                   |   |
|---|-------------------|---|
| Effective Date:<br>07/01/2012                 | <b>Herbicides</b> | Standard Number:<br><b>HSE 4400.080(KY)</b> |
| Supersedes:<br>09/20/1995<br>HSE 4400.080(CG) |                   | Page 1 of 19                                |

Companies Affected:

|                                 |   |                              |
|---------------------------------|---|------------------------------|
| <input type="checkbox"/> NIPSCO | <input type="checkbox"/> CGV            | <input type="checkbox"/> CMD |
|                                 | <input checked="" type="checkbox"/> CKY | <input type="checkbox"/> COH |
|                                 | <input type="checkbox"/> CMA            | <input type="checkbox"/> CPA |

- REFERENCE**
- 40 CFR 152.175 Pesticides Classified for Restricted Use;
  - 40 CFR 156 Labeling Requirements for Pesticide Devices;
  - 40 CFR 165 Regulations for the Acceptance of Certain Pesticides and Recommended Procedures for the Disposal and Storage of Pesticides and Pesticide Containers;
  - 40 CFR 171 Certifications of Pesticide Applicators

**1. SCOPE**

This document provides standard practices for the storage, transportation, handling and application of herbicides on NiSource Gas Distribution Operations owned and/or managed property or rights-of-way. The intent of this guidance document is to encourage the use of herbicides that minimize environmental risk through applications of primarily non-restricted use herbicides. The proper herbicide mix selection, herbicide application rate and application method, partnered with the appropriate training is an integral part of a sustainable approach to vegetation management.

**2. APPLICABILITY**

This document applies to all employees and facilities that apply or have herbicides applied to NiSource Gas Distribution Operations property or NiSource Gas Distribution Operations managed rights of way, as well as facilities which store or otherwise handle herbicide or herbicide application equipment. Herbicides are commonly used for brush and broadleaf weed control, for bare ground vegetation control and for grass growth regulation (to reduce the need for mowing).

**3. DEFINITIONS**

**Certified Applicator:** An individual who is certified by an outside agency to use, apply or supervise the use of any pesticide/herbicide covered by his certification.

**General Use Herbicide:** An herbicide that is not listed as a Restricted Use Herbicide by either the Federal government or the State regulatory agency in which the application, storage, or transport will occur. An herbicide that is less likely to cause harm to people or the environment than a restricted use herbicide.

**Herbicide:** A category of pesticide used to kill or regulate the growth of plants or weeds.

*This document is considered CONTROLLED only when viewed electronically on the Company's intranet. Printed or other electronic copies may not be current, and the intranet version should be used to verify.*



Distribution Operations

## Health, Safety and Environmental Standard

|   |                   |   |
|---|-------------------|---|
| Effective Date:<br>07/01/2012                 | <b>Herbicides</b> | Standard Number:<br><b>HSE 4400.080(KY)</b> |
| Supersedes:<br>09/20/1995<br>HSE 4400.080(CG) |                   | Page 2 of 19                                |

**Herbicide Applicator:** Any person who applies herbicides to NiSource property or rights-of-way.

**NiSource IVM Team:** An EH&S Team, comprised of various Business Segment employees, knowledgeable and experienced in the use and management of herbicides. (See Appendix F.)

**Non-Selective Herbicide:** Herbicides designed to kill all vegetation and are used for bare ground vegetative control.

**Pesticide:** Any substance or mixture of substances intended for preventing, destroying, repelling or mitigating any pest or intended for use as a plant regulator, defoliant or desiccant.

**Project Manager:** Any person who is responsible for or who directs the application of herbicides onto NiSource property or rights-of-way. **If a restricted use herbicide is applied by NiSource personnel, the Project Manager must be the certified applicator.** In addition, if a general use herbicide is applied by NiSource personnel in a State where general use herbicides must be applied under the direct supervision of a certified applicator, the Project Manager must be a certified applicator.

**Restricted Use Herbicide:** Herbicides that are classified by the EPA under the Federal Insecticide, Fungicide and Rodenticide Act. Restricted use herbicides are considered to be more likely (than a general use herbicide) to cause harm to people or the environment unless it is applied by or under the supervision of a certified applicator.

**Selective Herbicide:** Herbicides designed to control brush and broad leaf weeds without harming grasses.

**Under the Direct Supervision of:** The process whereby the application of a herbicide is made by a competent person(s) acting under the instructions and control of a certified applicator. **The certified applicator is responsible for the herbicide application and must be available, if and when needed, during herbicide application.** However, the certified applicator does not necessarily need to be physically present during herbicide application.

#### 4. PRE-APPLICATION CONSIDERATION

##### 4.1 Aesthetic Areas

In areas of high aesthetic value, the herbicide applicator should evaluate the appropriateness of herbicide use. Should herbicides be utilized in a high aesthetic value area, the applications should be performed in a fashion to minimize vegetative brownout.



**Distribution Operations**

**Health, Safety and Environmental Standard**

|   |                   |   |
|---|-------------------|---|
| Effective Date:<br>07/01/2012                 | <b>Herbicides</b> | Standard Number:<br><b>HSE 4400.080(KY)</b> |
| Supersedes:<br>09/20/1995<br>HSE 4400.080(CG) |                   | Page 3 of 19                                |

**4.2 Federal/State Lands**

Federal or State lands, including but not limited to Federal/State forests, parks, and wildlife management areas, should not be sprayed without prior notification of and written permission from the appropriate authority.

**4.3 Spill Prevention**

Prior to mixing liquid herbicides, a supply of absorptive material such as vermiculite, activated charcoal, absorptive clay, hydrated lime, sodium hypochlorite, or other such materials should be available at each mixing location for immediate application to accidental spills.

**4.4 Personnel Protection**

Any protective clothing and equipment required by the label for mixing, application, and clean up after herbicide application must be worn or used.

An adequate supply of water and soap should be available at the mixing location for washing and spill cleanup. Personnel should have access to cleansing materials and should wash as soon as possible after handling herbicides and prior to eating, drinking, using tobacco, or the toilet.

Protective clothing shall be removed after handling herbicides and laundered separately before being worn again. At a minimum, non-porous gloves and splash proof glasses or goggles shall be worn while handling, mixing, and applying herbicides.

**4.5 Mixing Herbicides**

Ingredients must be measured accurately and mixed thoroughly prior to application. Use the exact amounts shown on the label to achieve the desired results with the target species. The label is the law. Only mix the quantity of herbicides necessary to perform the intended application within the time available.

Herbicide mixtures ordinarily should not be prepared for more than one or two day's use. Exceptions may be made for preparing stock mixtures and carrier for use in backpack spray application equipment or other similar low volume application equipment. These mixtures may be made up in convenient quantities sufficient to last over the several-day duration of an application program. Such mixtures must be labeled and stored in compliance with all State and Federal regulations.

**4.5.1 Water Source Protection**

Any water source providing water for mixing should be protected from herbicide contamination. Water collecting equipment, such as buckets, hoses, etc., which





**Distribution Operations**

**Heath, Safety and Environmental Standard**

|   |                   |   |
|---|-------------------|---|
| Effective Date:<br>07/01/2012                 | <b>Herbicides</b> | Standard Number:<br><b>HSE 4400.080(KY)</b> |
| Supersedes:<br>09/20/1995<br>HSE 4400.080(CG) |                   | Page 4 of 19                                |

are immersed in a water source, must not be contaminated with or have held herbicides prior to their use for water collection. Kentucky requires the use of anti-siphon devices on water intake hoses to herbicide application equipment.

**4.6 Weather Conditions**

The weather forecast should be checked prior to herbicide application. If certain weather conditions are to be avoided for herbicide application, they will be noted on the herbicide label.

No broadcast herbicides should be applied during fog; high wind conditions; or immediately before, during, or after rain.

**4.7 Notifications**

Kentucky does not require prior notification to individuals having property in or adjacent to areas where herbicides will be used,

**5. HERBICIDE APPLICATION**

**5.1 General**

Any vehicle used in herbicide applications shall display the business license number.

The following general provisions should be followed for all herbicide applications:

- a. Keep unauthorized and unnecessary persons away from the area being treated.
- b. Continuous surveillance should be maintained to assure that herbicide sprays or materials do not drift off the target area.
- c. Application of herbicides should be limited to the area necessary for facility maintenance or aerial inspection of the pipeline.
- d. To avoid herbicide spills and contamination of areas not scheduled for treatment, the entire application system should be checked for leaks periodically during application. Such equipment should have a positive shutoff mechanism capable of retarding “drool.”
- e. Cease herbicide application when any potentially unsafe condition is observed such as:
  - Unauthorized persons in the vicinity of the application,
  - Farm animals, domestic animals or wildlife in the vicinity of the application,
  - Change in weather conditions.



**Distribution Operations**

**Health, Safety and Environmental Standard**

|   |                   |   |
|---|-------------------|---|
| Effective Date:<br>07/01/2012                 | <b>Herbicides</b> | Standard Number:<br><b>HSE 4400.080(KY)</b> |
| Supersedes:<br>09/20/1995<br>HSE 4400.080(CG) |                   | Page 5 of 19                                |

- f. Do not enter or allow others to enter treated areas for the time specified on the label. If no time limit is specified, wait until the sprayed area has dried before entering.
- g. If the herbicide applicator(s) will leave an application area before the herbicide has dried or before the access time limit specified on the label, and there is the possibility of entry into the area by others, the application area should be marked to control unauthorized access to the area.

**5.2 Ground Applications**

The following should be observed for ground applications of herbicide:

- a. Care should be taken that herbicides do not enter: orchards; pastures; agricultural fields; recreational or human use areas; or open bodies of water such as streams, ditches, lakes or ponds.
- b. Unless a greater distance is specified on the label, no herbicide should be applied within 25 feet of an open body of water. However, several herbicides including Glyphosate, Krenite S, Krenite UT, Rodeo and others may be used adjacent to water bodies in accordance with label instructions and approval from the NiSource IVM Team.
- c. When not in use, application equipment should be relieved of pressure, all valves closed, and the equipment returned to the storage area.
- d. Application equipment should not be left unattended in the field or mixing area.

**5.3 Aerial Applications**

To avoid drift and unintentional off target aerial application, the following considerations should be observed:

- a. Aerial spray applications of herbicide should be made with spray boom types that are of drift minimizing design.
- b. Aerial applications should be performed only when the wind speed is less than eight miles per hour.
- c. During aerial applications, the aircraft should fly at the safest minimum altitude. A fall of 30 to 40 feet above treetop level is recognized as the optimal fly distance to minimize drift and volatilization.
- d. Aircraft should avoid flying over open water and inhabited areas on routes to and from the application area whenever practical.
- e. Aerial spraying should not be performed within 100 feet (200 feet for picloram) of orchards; pastures; agricultural fields; recreational or human use area; or open water bodies such as streams, ditches, lakes or ponds



**Distribution Operations**

**Health, Safety and Environmental Standard**

|   |                   |   |
|---|-------------------|---|
| Effective Date:<br>07/01/2012                 | <b>Herbicides</b> | Standard Number:<br><b>HSE 4400.080(KY)</b> |
| Supersedes:<br>09/20/1995<br>HSE 4400.080(CG) |                   | Page 6 of 19                                |

(the buffer zone).

- f. When treating slopes in excess of 30 percent, the buffer zone should be increased to 200 feet (for picloram 300 feet).
- g. When the wind velocity exceeds 4 mph, the buffer zone for all herbicide application should be increased to 500 feet.
- h. Aerial application of picloram should not be performed more often than once every three years and must be in accordance with all State and Federal Regulations.

**5.4 General Use Herbicides**

Application of general use herbicides must be made under the supervision of a state Certified Commercial Applicator. Herbicides must be applied in a manner consistent with their label directions. **The label is the law**

**5.5 Restricted Use Herbicides**

No Restricted Use Herbicides will be utilized without NiSource IVM Team review and approval. (See Exhibit A for the list of approved and not approved herbicide listing). Federal regulations and Kentucky regulations require that restricted use herbicides be applied only by or under the direct supervision of a certified applicator. The applicator must be certified in Kentucky.

**5.6 Employee Herbicide Application**

All herbicide applications should be completed by a third party licensed contractor. All employees who apply **herbicides** in Kentucky must either:

- a. Be certified as a commercial applicator in Kentucky or;
- b. Be state registered and complete a state approved training program. The state Certified Commercial Applicator must be on site when herbicides are applied.

To obtain training and licenses contact the Kentucky Department of Agriculture. Application instructions include herbicide handling, mixing, application, storage, disposal, spill cleanup, use of protective clothing and equipment, emergency first aid procedures for contact exposure, and the need for personal hygiene. Application training/instruction records must be maintained.

**6. REPORTING REQUIREMENTS**

**6.1 Herbicide incidents**

All herbicide spills shall be reported to the Kentucky Department of Natural Resources.



## Health, Safety and Environmental Standard

|   |                   |   |
|---|-------------------|---|
| Effective Date:<br>07/01/2012                 | <b>Herbicides</b> | Standard Number:<br><b>HSE 4400.080(KY)</b> |
| Supersedes:<br>09/20/1995<br>HSE 4400.080(CG) |                   | Page 7 of 19                                |

### 6.2 Spill Cleanup

If an herbicide spill, accident, incident, or off right of way damage occurs:

- a. Follow the procedures outlined in Environmental Occurrence Reporting HSE 4400.020 for reporting releases in accordance with Company policy.
- b. In addition to the spill reporting requirements listed above; contact the herbicide application Project Manager, the facility supervisor and the certified applicator.
- c. If the herbicide label does not specify any cleanup instructions, then the following should be used:

### 6.3 Liquid Spills

Cover up the spill area with absorptive material and soak up as much as possible. Then sweep or shovel the contaminated material and any directly underlying soil into a metal container that can be tightly closed. Cover the spill area with hydrated lime or sodium hypochlorite (except for sodium tetra borate spills that do not require this treatment).

The contained liquid spill residue shall be handled in accordance with approved waste management practices.

### 6.4 Granular or Powder Spills

Sweep or shovel the material and any underlying soil directly into a metal container that can be tightly closed.

## 7. HERBICIDE STORAGE

### 7.1 General

The following general practices should be followed for the storage of herbicides:

- a. All containers of herbicide shall be appropriately labeled with product name and safety labels.
- b. The herbicide label should be read and any specifics with regard to the storage of herbicides should be followed.
- c. Where practical, storage areas should not be in the floodplain.
- d. A Product Label and a Material Safety Data Sheet must be available for each herbicide at the facility where the herbicide is stored.
- e. Opened containers should be tightly closed prior to returning them to storage.



**Distribution Operations**

**Health, Safety and Environmental Standard**

|   |                   |   |
|---|-------------------|---|
| Effective Date:<br>07/01/2012                 | <b>Herbicides</b> | Standard Number:<br><b>HSE 4400.080(KY)</b> |
| Supersedes:<br>09/20/1995<br>HSE 4400.080(CG) |                   | Page 8 of 19                                |

- f. Pesticide containers should be checked regularly for corrosion and leaks. If such is found the container should be transferred to a sound, suitable larger container, and properly labeled.
- g. A supply of absorptive material such as vermiculite, activated charcoal, absorptive clay, hydrated lime, sodium hypochlorite, or other such materials should be maintained at every location where liquid herbicides are stored where the concentrate container size or total stored quantity equals or exceeds 30 gallons.
- h. Large inventories of herbicides should not be maintained year round in any storage area. Herbicide purchases should be based on anticipated annual herbicide volume use requirements. Quantities in excess of 300 gallons of liquid herbicide or 300 pounds of dry chemicals shall not be stored on company property.

**7.2 Indoor Storage**

Herbicides should be stored in a dry, well ventilated, separate room, building or covered area where fire protection is provided. Ideally, herbicides should not be stored in the proximity of floor drains. If storage near floor drains cannot be avoided the means to protect the drains from spill releases must be readily available. Access to the area should be limited. A locked storage area is preferable. All containers should be stored off the floor on shelves or on pallets and in an orderly manner with their labels clearly visible.

**7.3 Outdoor Storage**

Outdoor storage of Restricted Use Herbicides is prohibited. Short term, temporary outdoor drum storage of general use herbicides is not recommended, however, permissible if the storage area is fenced and locked. If any drums are equipped with a spigot, that spigot must be locked.

**7.4 Herbicide Storage Area Labeling**

Herbicide storage areas should be labeled in accordance with the following:

- a. Signs identifying all herbicide and equipment storage areas should be posted. The posting should contain the following information:
- b. The outside of each storage area should be plainly labeled with the words "Danger", "Poison", "Herbicide Storage" or "Pesticide Storage" as appropriate.
- c. A list of the types of chemicals stored in the storage area should be posted on the outside of the storage area. The list should be updated periodically to identify the type and quantity of herbicides stored.



**Distribution Operations**

**Health, Safety and Environmental Standard**

|   |                   |   |
|---|-------------------|---|
| Effective Date:<br>07/01/2012                 | <b>Herbicides</b> | Standard Number:<br><b>HSE 4400.080(KY)</b> |
| Supersedes:<br>09/20/1995<br>HSE 4400.080(CG) |                   | Page 9 of 19                                |

- d. In addition, the area should be posted with appropriate signage indicating:
- That unauthorized persons should keep out,
  - An emergency contact name and phone number to be contacted in the event of a release or exposure and,
  - Safety precautions that should be followed.

Examples of appropriate signs are shown in Exhibit C and D.

**7.5 Transportation of Herbicides**

The following general considerations should be observed when transporting herbicides:

- a. Care must be exercised in moving herbicides to prevent damaging or breaking containers.
- b. Containers should be placed on vehicles so they do not shift, roll, or bounce around during transportation.
- c. Herbicides must not be carried in the passenger compartment of trucks or cars.
- d. Inspect all vehicles following herbicide transportation and clean those found to be contaminated.
- e. Proper shipping papers and placarding must be used if the total weight of chemicals on the vehicle exceeds 8 gallons of liquid herbicide or 55 pounds of dry chemical herbicide. Quantities over 300 pounds of dry chemicals and 300 gallons of liquid herbicide shall not be transported in company owned or operated vehicles.

**7.6 Container Disposal**

Used herbicide containers can be disposed by:

- a. Flushing the container three times using 10% of the container volume of fresh water for each flush.
- b. Save the rinse water to be added to the next preparation of herbicide mixture. The rinse water must be properly labeled.
- c. Render the container unusable by crushing, flattening, or puncturing.
- d. Dispose of the unusable empty container in accordance with Kentucky state requirements

|   |                   |   |
|---|-------------------|---|
| Effective Date:<br>07/01/2012                 | <b>Herbicides</b> | Standard Number:<br><b>HSE 4400.080(KY)</b> |
| Supersedes:<br>09/20/1995<br>HSE 4400.080(CG) |                   | Page 10 of 19                               |

### 7.7 Disposal of Herbicides/Herbicide Mixtures

An effort should be made to avoid disposal of herbicides. This may be accomplished by using the herbicide for its originally intended purpose.

Herbicide residues and rinse liquids should be used in preparing identical herbicide mixtures. However, when using rinse liquids in preparing new herbicide solutions, care should be taken that the maximum allowable herbicide concentration for the herbicide application, as described on the label, is not exceeded.

When herbicides or herbicide mixtures cannot be used or returned to the manufacture, they must be properly disposed. Some herbicides/herbicide mixtures and spill cleanup residues may be a hazardous waste and should be stored, handled, and disposed in accordance with existing approved waste management practices. In addition, universal waste provisions may also be applicable to some herbicide wastes. For assistance with the determination of waste disposal requirements and options, contact the EH&S Department at (219) 647-5247.

## 8. HERBICIDES APPROVED FOR USE

Exhibit A provides a list of herbicides approved for use by employees and contractors on NiSource owned or managed property. Herbicides and herbicide formulations not approved in Exhibit A are prohibited from use on NiSource property or rights-of-way unless specifically approved for use by the NiSource IVM Team. (For a list of contacts for the IVM team see definitions.)

### 8.1 New Herbicides

#### 8.1.1 Requests

Requests for the approval of new herbicides/herbicide formulations should be made to the NiSource IVM Team.

A copy of the MSDS sheet for the new herbicide product as well as the application conditions proposed for the herbicide should be forwarded along with the request for approval.

#### 8.1.2 Approval

The new herbicide will be evaluated based on review of the Product Label and the Material Safety Data Sheet for the product, contact with referred users of the product, possible visual inspection of applied product, contact with NiSource EH&S and/or discussion with the manufacturer's technical contact for the new herbicide. Once the review process is completed, the NiSource IVM Team will issue a written approval summarizing which type of applications for the product are acceptable or a summary of why the product is unacceptable





**Distribution Operations**

**Health, Safety and Environmental Standard**

|   |                   |   |
|---|-------------------|---|
| Effective Date:<br>07/01/2012                 | <b>Herbicides</b> | Standard Number:<br><b>HSE 4400.080(KY)</b> |
| Supersedes:<br>09/20/1995<br>HSE 4400.080(CG) |                   | Page 11 of 19                               |

for use.

**9. HERBICIDE APPLICATION CONTRACTS**

Prospective new herbicide application contractor requests should be submitted to the NiSource IVM Team. Information submitted should include:

- a. Contractor name, address and telephone number
- b. Contact Person

An environmental review of the contractor should be performed. If the review is satisfactory, a Service Agreement may be initiated. The process may include a legal review of the agreement.

**10. RESPONSIBILITIES**

Each employee and contractor responsible for the handling, storage, or application of herbicides must be familiar with the provisions of this plan. Facility personnel are responsible to ensure the proper storage of herbicides at their facility. The Project Manager for the herbicide application project is responsible for compliance with all applicable sections of this plan. Employees and contractors applying herbicides are responsible for obtaining the necessary training, registration, licensing or certification prior to herbicide application. Additionally, each applicator must read, understand and follow the label directions before mixing, applying, storing, or disposing of herbicides.

The Project Manager/certified applicator is accountable for completion of the following tasks. The responsibilities include, but are not limited to:

- a. Ensuring proper storage, handling, application, transportation and disposal of herbicides or herbicide products.
- b. Ensuring that the label directions are followed for the storage, mixing and application of herbicides.
- c. Ensuring that applicable laws and regulations are followed for herbicide applications.
- d. Ensuring that contractors applying herbicide are properly qualified and meet the NiSource insurance and indemnification requirements.
- e. Ensuring that proper training and instruction is given to NiSource personnel who will be applying herbicide under the Project Manager's supervision, as required, and that proper records are kept of such training.
- f. Ensuring that prior notifications of herbicide application are made as necessary and any necessary approvals for the application of herbicides are obtained prior to application.





**Distribution Operations**

**Health, Safety and Environmental Standard**

|   |                   |   |
|---|-------------------|---|
| Effective Date:<br>07/01/2012                 | <b>Herbicides</b> | Standard Number:<br><b>HSE 4400.080(KY)</b> |
| Supersedes:<br>09/20/1995<br>HSE 4400.080(CG) |                   | Page 12 of 19                               |

- g. Ensuring that proper records of application are completed and maintained, if required.
- h. Ensuring that only approved herbicides or herbicides reviewed and approved by the NiSource IVM Team are applied to NiSource property or rights-of-way.
- i. Ensuring that requests for approval of new herbicides proposed for use or new herbicide application contractors are submitted to the NiSource IVM Team.

The NiSource IVM Team is responsible for review of new herbicide application contractors, as requested. The NiSource IVM Team is also responsible for the review and approval (or disapproval) of new herbicides proposed for use on NiSource property or rights-of-way.

NiSource IVM Team will be available as support, as needed, in carrying out this plan; will provide guidance (as necessary); and initial implementation or roll-out of new or revised requirements relative to herbicides and herbicide application. The NiSource IVM Team will also maintain an updated listing of areas where there are herbicide application restrictions and will make this listing available to personnel applying herbicides.

**11. RECORDS**

At a minimum, the following records should be maintained by the herbicide application Project Manager/certified applicator or in the facility files:

- a. Copies of the certified herbicide applicators license(s), registration(s), certification(s) where necessary, for persons responsible for overseeing the herbicide application.
- b. An inventory of herbicides in storage.
- c. Records of Herbicide applications, where appropriate. The form in Exhibit B shall be used to record employee herbicide applications.
- d. Certified Applicator and/or Registered Technician training records.

Employee application records shall be maintained for three years.

**12. REGULATORY CITATIONS AND EXCEPTIONS**

**12.1 Federal Requirements**

Federal Environmental Protection Agency regulations referenced in this plan are located in 40 CFR 152 through 186.

**12.2 Kentucky Requirements**

Where Kentucky requirements are more stringent than the federal requirements, the Kentucky requirements must be followed.



Distribution Operations

Health, Safety and Environmental Standard

|   |                   |   |
|---|-------------------|---|
| Effective Date:<br>07/01/2012                 | <b>Herbicides</b> | Standard Number:<br><b>HSE 4400.080(KY)</b> |
| Supersedes:<br>09/20/1995<br>HSE 4400.080(CG) |                   | Page 13 of 19                               |

**EXHIBIT A  
(1 of 4)**

**APPROVED HERBICIDE FORMULATIONS**  
**(Selective)\***

| <u>Common Name/Brand Name</u>                      | <u>Active Ingredient</u>   | <u>Comments</u>  |
|--|--|--|
| Fosamine<br>KRENITE S, KRENITE UT                  | Ammonium ethyl<br>carbomoylphosphonate   |  |
| Triclopyr<br>GARLON, PATHFINDER                    | 3,5,6-trichloro-<br>2-pyridinyloxyacetic acid  |  |
| 2,4-D<br>SCOTTS PLUS 2<br>WEED-BE-GONE             | 2,4-dichlorophenoxyacetic<br>acid  | Scotts Plus 2 is an acid granular fertilizer. Various brands for lawn and turf type grasses which promotes grass growth and helps eliminate weeds. Weed-Be-Gone is available as a ready-to-use liquid for selectively killing broadleaf weeds in turf areas. Both products contain 2,4-D and MCPP. |
| 2,4-DP Various brands                              | 2-(2,4-dichlorophenoxy)<br>propionic acid  |  |
| Milestone VM aminopyralid                          | Triisopropanolammonium salt of<br>2-pyridine carboxylic acid, 4<br>amino-3,6-dichloro- 2.22%<br>Triethylamine Salt of [(3,5,6-<br>trichloro-2-pyridinyloxy] acetic<br>acid) - 16.22% |  |
| * Selective means suppression of broadleaf plants. |  |  |



Distribution Operations

Health, Safety and Environmental Standard

|   |                   |   |
|---|-------------------|---|
| Effective Date:<br>07/01/2012                 | <b>Herbicides</b> | Standard Number:<br><b>HSE 4400.080(KY)</b> |
| Supersedes:<br>09/20/1995<br>HSE 4400.080(CG) |                   | Page 14 of 19                               |

**EXHIBIT A  
(2 of 4)**

**APPROVED HERBICIDE FORMULATIONS  
(NONSELECTIVE)\*\***

| Common Name/Brand Name                           | Active Ingredient  | Comments  |
|--|--|---|
| Atrazine<br>AATREX                               | 2 – chloro - 4 (ethylamino) – 6 – (isopropylamino) – s - triazine  |   |
| Chlorsulfuron<br>TELAR                           | 2 – chloro – N [ (4 – methoxy – 6 – methyl – 1,3,5 – triazin – 2 – yl) aminocarbonyl] – benzenesul fonamide      |   |
| Diuron<br>KARMEX                                 | 3 – (3,4 – dichlorophenyl) – 1.1 – dimethylurea  |   |
| Glyphosate<br>ROUNDUP, RODEO,<br>ACCORD, HOEDOWN | N – (phosphonomethyl) glycine  | Broad spectrum herbicide applied as spray to foliage of grasses, weeds and brush; extremely safe for use near desirable vegetation because it has no soil residual activity |
| Imazapyr<br>ARSENAL, CHOPPER                     | 2 – (4 – isopropyl – 4 – methyl – 5 – oxy – 2 – imidazolin – 2 – yl) nicotinic acid                              |   |
| Mefluidide<br>EMBARK                             | N – [2.4 – dimethyl – 5 – [(trifluoromethyl) sulfonyl] amino] penyl] acetamide                                   | General use grass regulator   |
| Metsulfuron<br>ESCORT                            | Methyl – 2 – [ [(4 – methoxy – 6 – methyl – 1,3,5 – triazin – 2 – yl) amino] carbonyl] amino] sulfonyl] benzoate |   |
| Prometone<br>PRAMITOL 5PS<br>PRAMITOL 25E        | 2, 4 – bis – (isopropylamino) – 6 – methoxy – s – triazine   | Granular or liquid, soil – active herbicide for bare ground vegetation control  |
| Simazine<br>PRINCEP                              | 2 – chloro – 4,6 – bis (ethylamino) – s – triazine   |   |
| Sulfometuron methyl<br>OUST                      | Methyl 2 – ( [(4, 6 – dimethyl – 2 – pyrimidinyl) amino] carbonyl] amino) sulfonyl] benzoate                     |   |



**Distribution Operations**

**Health, Safety and Environmental Standard**

|   |                   |   |
|---|-------------------|---|
| Effective Date:<br>07/01/2012                 | <b>Herbicides</b> | Standard Number:<br><b>HSE 4400.080(KY)</b> |
| Supersedes:<br>09/20/1995<br>HSE 4400.080(CG) |                   | Page 15 of 19                               |

\*\*Nonselective means elimination of all vegetation

**EXHIBIT A  
(3 of 4)**

**RECOMMENDED LIMITED-USE HERBICIDES\***

| Common Name / Brand Name      | Active Ingredient  | Comments  |
|-------------------------------|--|---|
| Bromacil<br>HYVAR             | 5 – bromo – 3 – sec – butyl –<br>6 – methyliracil  | Nonselective herbicide  |
| UREABOR                       | Sodium metaborate<br>tetrahydrate, sodium chlorate,<br>5 – bromo – 3 – sec – butyl –<br>6 – methyluracil | Nonselective herbicide  |
| Picloram**<br>TORDON, PATHWAY | 4 – amino – 3, 5, 6 – trichloro<br>– picolinic acid  | Selective herbicide Piclorom<br>shall not be applied more<br>often than once every three<br>years |
| ACCESS                        |  |   |

\*These herbicides are to be used only when (a) selective and nonselective herbicides (EXHIBIT A and B) have been considered and found to be inadequate and (b) herbicide use is limited to small – scale applications of one acre or less, except PICLORAM. Area larger than one acre may be treated if no off – site drainage is possible.

\*\* All products formulations containing PICLORAM, except TORDON RTU, TORDON 101R and PATHWAY are classified by the EPA as Restricted Use Herbicides and can only be applied by Commercial Applicators certified in the state where application is made.



**Distribution Operations**

**Health, Safety and Environmental Standard**

|   |                   |   |
|---|-------------------|---|
| Effective Date:<br>07/01/2012                 | <b>Herbicides</b> | Standard Number:<br><b>HSE 4400.080(KY)</b> |
| Supersedes:<br>09/20/1995<br>HSE 4400.080(CG) |                   | Page 16 of 19                               |

**EXHIBIT A  
(4 of 4)**

**HERBICIDE FORMULATIONS NOT APPROVED FOR USE**

|                    |                   |                    |
|--------------------|-------------------|--------------------|
| NORKEM 660         | PARCH FORMULA 190 | PARCH FORMULA 267B |
| VELPAR             | KROVAR I          | UREABOR            |
| TORDON 10K PELLETS | VOID              | WITHER             |

Non-approved also includes any herbicides not recommended for general (Exhibits A and B) or limited (Exhibit C) use.



**Distribution Operations**

**Health, Safety and Environmental Standard**

|   |                   |   |
|---|-------------------|---|
| Effective Date:<br>07/01/2012                 | <b>Herbicides</b> | Standard Number:<br><b>HSE 4400.080(KY)</b> |
| Supersedes:<br>09/20/1995<br>HSE 4400.080(CG) |                   | Page 17 of 19                               |

**EXHIBIT B**

**COLUMBIA GAS**

**Distribution Companies**

**Limited-Use Herbicide Record**

|  |  |  |       |
|--|--|--|-------|
| COMPANY<br>CKY CMD COH CPA CGV CMA           |  | OPERATING CENTER:                                    |       |
| Application Rate: (gal./acre or pounds/acre) |  | Principal Pest Treated: ( Weeds, brush, trees, ect.) |       |
| Date Herbicide Application:                  |  | Herbicide Used:                                      |       |
| Total Area Treated:                          |  |  |       |
| Location Treated:                            |  |  |       |
| Remarks:                                     |  |  |       |
| Employee Signature:                          |  |  | Date: |
| <b>Note:</b> File                            |  |  |       |



Distribution Operations

Health, Safety and Environmental Standard

|   |                   |   |
|---|-------------------|---|
| Effective Date:<br>07/01/2012                 | <b>Herbicides</b> | Standard Number:<br><b>HSE 4400.080(KY)</b> |
| Supersedes:<br>09/20/1995<br>HSE 4400.080(CG) |                   | Page 18 of 19                               |

EXHIBIT C

**CAUTION**

**THIS AREA CONTAINS HERBICIDES  
UNAUTHORIZED PERSONS KEEP OUT**

IN CASE OF EMERGENCY CONTACT:

\_\_\_\_\_  
NAME

\_\_\_\_\_  
HOME PHONE NO.

**READ PRIOR TO ENTERING AREA**

1. WEAR NON-POROUS GLOVES AND SPLASH-PROOF GOGGLES IF HERBICIDES ARE TO BE HANDLED WHILE IN THIS AREA.
2. READ ALL LABELED INSTRUCTIONS. IF HERBICIDES ARE TO BE HANDLED, WEAR ALL PROTECTIVE CLOTHING REQUIRED BY LABEL.
3. INSPECT CONTAINERS FOR LEAKS BEFORE HANDLING. HANDLE CONTAINERS AND PACKAGES WITH CARE.
4. DO NOT TRANSPORT FOOD, GRASS SEED OR ARTICLES INTENDED FOR HUMAN CONSUMPTION WITH HERBICIDES.
5. HERBICIDES MUST NOT BE CARRIED IN ANY VEHICLE PASSENGER COMPARTMENT. INSPECT ALL VEHICLES FOLLOWING HERBICIDE TRANSPORTATION AND TREAT THOSE FOUND TO BE CONTAMINATED.
6. DO NOT STORE FOOD, BEVERAGES, TOBACCO, EATING UTENSILS, OR SMOKING EQUIPMENT IN THIS AREA. DO NOT DRINK, EAT, SMOKE OR USE TOBACCO IN THIS AREA.
7. DO NOT PUT FINGERS IN MOUTH OR RUB EYES WHILE WORKING WITH HERBICIDES.
8. WASH HANDS BEFORE EATING, SMOKING OR USING TOILET AND IMMEDIATELY AFTER HANDLING HERBICIDES.



**Distribution Operations**

**Health, Safety and Environmental Standard**

|   |                   |   |
|---|-------------------|---|
| Effective Date:<br>07/01/2012                 | <b>Herbicides</b> | Standard Number:<br><b>HSE 4400.080(KY)</b> |
| Supersedes:<br>09/20/1995<br>HSE 4400.080(CG) |                   | Page 19 of 19                               |

**EXHIBIT D**







**Health, Safety and Environmental Standard**

**Distribution Operations**

|                               |   |  |
|-------------------------------|---|--|
| Effective Date:<br>12/12/1998 | <b>Hazardous Materials<br/>Transportation</b> | Standard Number:<br><b>HSE 4410.010(CG)</b><br>P&P 435-1 |
| Supersedes:<br>N/A            |   | Page 1 of 5  |

Companies Affected:

|                                     |   |   |
|-------------------------------------|---|---|
| <input type="checkbox"/> NIPSCO     | <input checked="" type="checkbox"/> CGV | <input type="checkbox"/> CMD            |
| <input type="checkbox"/> NIFL       | <input checked="" type="checkbox"/> CKY | <input checked="" type="checkbox"/> COH |
| <input type="checkbox"/> Kokomo Gas | <input type="checkbox"/> CMA            | <input type="checkbox"/> CPA            |

**REFERENCE** 49 CFR 172-180

**1. SCOPE & APPLICABILITY**

In the course of conducting business, Columbia Gas plant and service operations as well as the company's support functions such as warehouse operations frequently have the need to transport hazardous materials. Through the Hazardous Materials Regulations (HMRs), the US Department of Transportation (DOT) sets forth the rules and guidelines for the safe transportation of hazardous materials. Nearly all aspects of the transportation process are regulated including: classifying hazardous materials, preparing shipping papers, packaging, marking, labeling, offering a shipment to a carrier, loading and unloading, securing cargo as well as emergency management and employee training. Adherence to these rules will minimize the risks of hazardous materials transportation to Columbia Gas employees, the public, and the environment.

**2. EMPLOYEE TRAINING**

All employees require training within 90 days of assuming hazardous material transportation responsibilities. Within that 90 day period, untrained employees may perform hazardous material transportation functions only under the direct supervision of trained, knowledgeable employees.

Employees transporting only small quantities of hazardous materials that are used incidental to Columbia Gas' primary business, must complete training that meets the requirements of the "Materials of Trade Exception" (see paragraph 403.3) -- hazardous materials recognition, packaging, marking and load securement. Columbia Gas course #SF10113 "Materials of Trade: Hazardous Materials Training" meets these training requirements.

Employees involved in larger quantity shipments, or in the preparation of hazardous materials for transportation by carriers other than Columbia Gas (FedEx, UPS, US Postal Service, Roadway, etc.) must complete general awareness, function specific, driver (for drivers only), and safety training. Columbia Gas course # SF10112 meets these requirements.

All training must be documented. Employees must be retrained every three (3) years, when related job functions change and when they no longer demonstrate adequate proficiency in

*This document is considered CONTROLLED only when viewed electronically on the Company's intranet. Printed or other electronic copies may not be current, and the intranet version should be used to verify.*



**Distribution Operations**

**Health, Safety and Environmental Standard**

|                               |   |  |
|-------------------------------|---|--|
| Effective Date:<br>12/12/1998 | <b>Hazardous Materials<br/>Transportation</b> | Standard Number:<br><b>HSE 4410.010(CG)</b><br>P&P 435-1 |
| Supersedes:<br>N/A            |   | Page 2 of 5  |

hazardous materials transportation skills.

**3. MATERIALS OF TRADE EXCEPTION (MOT)**

The DOT has excepted small quantities of hazardous materials, other than hazardous wastes, from the full scope of the hazardous materials regulations when those materials are carried:

- a. for the purpose of protecting the health and safety of the driver or passengers,
- b. for the purpose of supporting the operation or maintenance of a motor vehicle (such as a fleet support vehicle), or
- c. by a motor carrier in direct support of a principal business that is other than transportation by motor vehicle.

This exception from the HMRs can be applied to most instances where Columbia Gas distribution companies transport hazardous materials. This exception does not imply that small quantities of hazardous materials are not dangerous, but rather that the burden created by fully complying with the HMRs is not justified considering the only marginal increase in safety that results. Therefore, the DOT has relaxed, not eliminated, requirements for qualifying hazardous materials shipments.

**3.1 MOT Quantity Limitations**

The MOT exception may only be applied to small quantities of hazardous materials. Quantity limitations are based on individual packagings and aggregate vehicle loads.

a. Packagings

For individual packagings of Packing Group II & III materials (Columbia Gas does not handle Packing Group I materials) and ORM-Ds (Consumer Commodities) the quantity limitations are:

- 1. liquids - 8 gallons,
- 2. solids - 66 pounds, and
- 3. compressed gases - gross cylinder weight not over 220 pounds.

b. Vehicle Totals

The aggregate gross weight of all MOTs on a motor vehicle may not exceed 440 pounds. A MOT may be transported on a motor vehicle under the MOT exception with other hazardous materials without affecting its eligibility for the exceptions.



**Distribution Operations**

**Health, Safety and Environmental Standard**

|                               |   |  |
|-------------------------------|---|--|
| Effective Date:<br>12/12/1998 | <b>Hazardous Materials<br/>Transportation</b> | Standard Number:<br><b>HSE 4410.010(CG)</b><br>P&P 435-1 |
| Supersedes:<br>N/A            |   | Page 3 of 5  |

**3.2 MOT Packaging**

Packagings must be leak tight for liquids and gases, sift proof for solids and be securely closed. Each material must be in the manufacturer's original packaging or a packaging of equal or greater strength and integrity. Outer packagings are not required for containers that are secured against movement in cages, carts, bins, boxes, and compartments. For gasoline, a packaging must be made of metal and conform to the requirements the HMRs or the requirements of the Occupational Safety and Health Administration (29 CFR 1910.106). A cylinder or other pressure vessel containing flammable or non-flammable compressed gas must conform to the packaging, qualification, maintenance and use requirements of the HMRs. Manifolding of cylinders is permitted under the MOT exception provided that all valves are tightly closed during transport.

**3.3 MOT Package Markings & Labeling**

Packagings must be marked with a common name or proper shipping name to identify the material it contains. The letters "RQ" must be on packagings that contain a reportable quantity of a hazardous substance. Compressed gas cylinders must be marked and labeled as prescribed in the HMRs -- 1) the DOT hazard warning label (3.9"x3.9" diamond label or shoulder label) and 2) the proper shipping name and, where applicable, "RQ."

**3.4 MOT Load Securement**

Packagings being transported under the MOT exceptions must be secured against relative movement and be protected from damage.

**4. HAZARDOUS MATERIAL TRANSPORTATION**

The requirements outlined in this section (4) apply to shipments of hazardous materials not excepted as Materials of Trade. The full scope of the HMRs applies to hazardous materials in excess of either individual packaging or aggregate vehicle MOT quantity limitations.

**4.1 Packaging**

Packagings used for the transport of hazardous materials shall be selected, maintained, filled and closed so that under normal conditions of transportation there will be no identifiable release of hazardous materials to the environment. When Columbia Gas distribution companies repackage hazardous materials into smaller containers, such containers shall meet the applicable performance-oriented or specification packaging requirements prescribed in 49 CFR 173. Only packages that show no signs of damage, leaks, or other reductions in integrity shall be used or refilled. Salvage drums and containers shall not be used as original packagings.



**Distribution Operations**

**Health, Safety and Environmental Standard**

|                               |   |  |
|-------------------------------|---|--|
| Effective Date:<br>12/12/1998 | <b>Hazardous Materials<br/>Transportation</b> | Standard Number:<br><b>HSE 4410.010(CG)</b><br>P&P 435-1 |
| Supersedes:<br>N/A            |   | Page 4 of 5  |

**4.2 Labeling**

DOT labels are warning symbols and words, in the prescribed 3.9" x 3.9" format, that are displayed on packagings. All non-bulk containers of hazardous materials shall be labeled as prescribed in 49 CFR 172 Subpart E with the primary hazard class label, and subsidiary hazard class label when necessary, except where limited quantity exceptions apply. Labels must not be affixed to the bottom of the packaging and must be in association with the proper shipping name and identification number. Labels shall not be removed from packages and shall be maintained in a legible condition even when not being transported (unless the hazard no longer exists).

**4.3 Marking**

All non-bulk containers of hazardous materials shall be marked as prescribed in 49 CFR 172 Subpart D with the:

- a. proper shipping name (with technical names as necessary),
- b. the identification number and
- c. the letters "RQ" when necessary.

Abbreviations may not be used in the proper shipping names except as authorized by the HMRs. Liquid hazardous materials in combination packagings (outer & inner packagings) must be packed with closures upward and legibly marked on two opposite sides of the outer packagings with orientation arrows showing the upright direction of the inner packaging. AMMONIA, ANHYDROUS, LIQUIFIED (UN 1005) cylinders must be marked with the words INHALATION HAZARD. All markings must be legible, in English, durable, of contrasting color to the background and unobscured by other labels and markings.

**4.4 Shipping Papers**

All shipments of hazardous materials must be accompanied by a shipping paper unless specifically excluded from this requirement. The shipping papers must comply with 49 CFR 172 Subpart C and include:

- a. identification as a shipping paper,
- b. page number and total pages ( # of #),
- c. an emergency response telephone number (CHEMTREC 1-800-424-9300),
- d. number of shipping units, proper shipping names, identification numbers, packing groups, hazard classifications,
- e. the letters "RQ" as necessary and
- f. total quantities.



**Distribution Operations**

**Health, Safety and Environmental Standard**

|                               |   |  |
|-------------------------------|---|--|
| Effective Date:<br>12/12/1998 | <b>Hazardous Materials<br/>Transportation</b> | Standard Number:<br><b>HSE 4410.010(CG)</b><br>P&P 435-1 |
| Supersedes:<br>N/A            |   | Page 5 of 5  |

The words INHALATION HAZARD must appear with shipping paper entries for AMMONIA, ANHYDROUS, LIQUIFIED. Other information may be required specific to the hazardous materials being transported.

**4.5 Placarding**

Placards are warning symbols and words, in the prescribed 14" x 14" format, that are displayed on vehicles and portable tanks. For hazardous materials transported by Columbia Gas, the DOT has established a placard threshold limit at 1000 pounds, below which no placarding is required. The HMRs detail more specific placarding requirements. When required, placards must be displayed on the front, rear and both sides of the transport vehicle. For combination vehicles, the front placard may be displayed on either (or both) the front of the motorized vehicle and the towed vehicle. Placards may not be obscured by ladders, piping, or other equipment on the vehicle. Placards must be displayed on backgrounds of contrasting colors.

**4.6 Emergency Response Information**

Any shipment of a hazardous material that must be accompanied by a shipping paper must also be accompanied by emergency response information (ERI). ERI must contain the following information: the basic description/shipping name of the material, immediate health hazards, fire and explosion hazards, immediate spill/accident handling instructions, methods for handling fires, and preliminary first aid measures. Carrying the latest version of the North American Emergency Response Guidebook in a driver's door pocket will meet the ERI requirements.



**Distribution Operations**

**Health, Safety and Environmental Standard**

|                               |   |   |
|-------------------------------|---|---|
| Effective Date:<br>11/01/2013 | <b>Construction, Operations and<br/>Maintenance Environmental Permitting<br/>and Compliance</b> | Standard Number:<br><b>HSE 4440.010</b> |
| Supersedes:<br>01/01/2012     |   | Page 1 of 8                             |

Companies Affected:

|                                 |   |   |
|---------------------------------|---|---|
| <input type="checkbox"/> NIPSCO | <input checked="" type="checkbox"/> CGV | <input checked="" type="checkbox"/> CMD |
|                                 | <input checked="" type="checkbox"/> CKY | <input checked="" type="checkbox"/> COH |
|                                 | <input checked="" type="checkbox"/> CMA | <input checked="" type="checkbox"/> CPA |

**1. SCOPE**

This plan provides the procedures necessary to perform an environmental evaluation prior to commencing any construction and/or maintenance activities. These procedures will ensure that the required environmental permits/clearances (which consist of wetland/water body, federal and state endangered species, cultural resources, hydrostatic testing water discharge, coastal zone, floodplain, and erosion and sediment control clearances) have been obtained or that there is documentation that no permits are required.

**2. APPLICABILITY**

This plan is applicable to any NiSource Gas Distribution (NGD) installation or retirement, operation and maintenance, or modification to an existing facility that is earth disturbing in nature, or may have a potential impact to an environmentally sensitive area, or would create or modify a discharge to the air or water.

**3. PROCEDURES**

**3.1 Project Initiation**

When field engineering issues a new capital job order, the Project Implementer or designated person will review the Project Environmental Information Form (PEIF). If any answers in the PEIF are "YES" or "UNSURE" then the PEIF will be forwarded to the Survey and Land (S&L) Group for review. The Project Implementer should use the PEIF to inform S&L about any nearby environmentally sensitive areas, the amount of earth disturbance proposed for the project, the need for hydrostatic water discharge, or necessary tree clearing.

If the project does not have a potential environmental impact and all the PEIF questions can be answered "NO" then the completed form shall be placed in the project file and the project can proceed while following the requirements of Environmental Construction Standards.

Most operations and maintenance activities can take place without the submission of a PEIF. These activities however must comply with the Environmental Construction Standards. In the event operations and maintenance activities will take place within an environmentally sensitive area, the project implementer shall contact S&L for coordination.

**3.2 Permitting**

Survey and Land will:

- Review the PEIF and project to determine if the environmental

*This document is considered CONTROLLED only when viewed electronically on the Company's intranet. Printed or other electronic copies may not be current, and the intranet version should be used to verify.*



**Distribution Operations**

**Health, Safety and Environmental Standard**

|                               |   |   |
|-------------------------------|---|---|
| Effective Date:<br>11/01/2013 | <b>Construction, Operations and<br/>Maintenance Environmental Permitting<br/>and Compliance</b> | Standard Number:<br><b>HSE 4440.010</b> |
| Supersedes:<br>01/01/2012     |   | Page 2 of 8                             |

impacts will require a permit or other approvals.

- Coordinate any necessary environmental surveys and assessments.
- Obtain permits or other approval documents.

**3.3 Clearance**

Survey & Land will provide the Project Implementer with a written, project-specific Environmental Compliance Plan (ECP) when the necessary permits and approvals have been obtained. The ECP will contain:

- Copies of permits and approvals obtained;
- Special conditions of permits;
- Authorization or denial of requests for variances from HSE 4440.020 “Environmental Construction Standard” (ECS)

Unapproved deviations from the ECP and ECS are not allowed. S&L may grant variances in writing if they are warranted. In an emergency situation, S&L may grant a verbal variance if it is followed up with written documentation. The Project Manager is responsible in an emergency situation to remedy the emergency and minimize the environmental impact. The Project Manager must notify S&L as soon as possible about the emergency situation.

If no permits or approval letters are required, S&L will notify the project implementer via email that the project may proceed as designed. The Project Manager shall submit a new PEIF if the scope of the project changes.

**3.4 Construction and Maintenance Compliance**

**3.4.1 General**

The Project Manager and an on-site Inspector are responsible for compliance with the environmental conditions contained in the Project’s ECP, which include all permits and other approvals, and the ECS.

**3.4.2 Environmental Inspector**

The Construction Inspector will act as the Environmental Inspector if a dedicated Environmental Inspector is not assigned. The Environmental Inspector is responsible for ensuring that the construction activity is performed in accordance with the environmental conditions of the ECP, the ECS and landowner requirements and has the authority to stop work and order appropriate corrective action. One or more Environmental Inspectors (Company or third party) will be assigned to every project as appropriate. At least one Environmental Inspector is required for each construction spread during active construction or restoration. Environmental Inspectors shall have peer status with all other activity inspectors. The Environmental Inspector may also serve to monitor other construction functions.

Refer to the current Environmental Construction Standard (ECS) for specific





**Distribution Operations**

**Health, Safety and Environmental Standard**

|                               |   |   |
|-------------------------------|---|---|
| Effective Date:<br>11/01/2013 | <b>Construction, Operations and<br/>Maintenance Environmental Permitting<br/>and Compliance</b> | Standard Number:<br><b>HSE 4440.010</b> |
| Supersedes:<br>01/01/2012     |   | Page 3 of 8                             |

responsibilities.

**3.4.3 Compliance Inspections**

S&L will, from time to time, perform compliance inspections of construction activities to review the implementation of the ECP and the ECS. S&L will have stop work authority during these inspections should deviations from the activity's ECP or the ECS occur. Any corrective actions that are required shall be taken as directed S&L. S&L will provide the Project Manager, and appropriate field personnel with the Project Compliance Inspection Report or other appropriate documentation of the inspection.

Should an agency inspection be conducted, the Project Manager or Inspector shall be responsible for notifying the S&L Group and HS&E as soon as possible. If prior notification is given by the agency, S&L and HS&E should be contacted to evaluate the need for their presence during the inspection. All efforts shall be made for the Environmental Inspector to accompany the agency inspector during the inspection. S&L and HS&E shall be provided copies of all agency inspection correspondence including notice of violations, inspection reports, Regulatory Agency Inspection-Report Information forms, etc. The Environmental Compliance Manager will be responsible for entering information into the Environmental Safety and Sustainability Agency Inspection database.

**4. RESPONSIBILITIES**

**4.1 Project Manager**

The project manager shall

- Provide information to the Permitter regarding the scope of the project and any relevant information to determine if any environmental permits or clearance letters are required.
- Ensure that all other non-environmental state and local permits for construction have been obtained (e.g. railroad crossing, road, building, blasting permits, etc.).
- Coordinate with S&L that an Environmental Inspector or designated person responsible to oversee the environmental conditions of the project be assigned to each project or construction spread;
- Verify that all inspectors on the project have been trained in all environmental aspects of the activity, and fully understands the environmental conditions contained in the project's ECP;
- Ensure that all company and contractor personnel will be informed of the Environmental Inspector's authority;





**Distribution Operations**

**Health, Safety and Environmental Standard**

|                               |   |   |
|-------------------------------|---|---|
| Effective Date:<br>11/01/2013 | <b>Construction, Operations and<br/>Maintenance Environmental Permitting<br/>and Compliance</b> | Standard Number:<br><b>HSE 4440.010</b> |
| Supersedes:<br>01/01/2012     |   | Page 4 of 8                             |

- Ensure that an environmental evaluation of the project has been performed, an ECP has been prepared, and project personnel are familiar with the ECP and have been or will be trained on environmental measures;
- Comply with all permits, regulations, ECP, ECS, and policies related to the project; and
- Forward maintenance conditions to appropriate Operations personnel.

**4.2 Survey and Land**

- Obtain all of the environmental permits and approvals required to begin construction;
- Prepare and distribute the ECP for the above projects to the Project Implementer;
- Provide technical support and guidance;
- Provide environmental training as necessary;
- Provide environmental inspection services; and
- Develop natural resource guidelines and processes.

**5. RECORDS**

For NiSource Gas Distribution projects, S&L will retain the following for 10 years:

- a. Original permits obtained;
- b. Original clearance letters obtained;
- c. All project specific portions of the ECP; and
- d. All original correspondence with regulatory agencies (federal, state and local); or
- e. Documentation that no permits are required.

The Project Manager, Construction Inspector, and Environmental Inspector for each project will retain a complete copy of the ECP on-site, including copies of the permits, clearances and special conditions or variances that apply to that project, until project is completed.

**6. DEFINITIONS**

**Construction Activity:** Any activity involving the installation, retirement, operation and maintenance or modification to an existing or new facility/right-of way (ROW), if it involves earth disturbance or is in or near an environmentally sensitive area.

**Environmental Construction Standard (ECS):** A NiSource Gas Distribution Company-specific document that defines the minimum environmental standards to be applied to all construction activities.



## Health, Safety and Environmental Standard

### Distribution Operations

|                               |   |   |
|-------------------------------|---|---|
| Effective Date:<br>11/01/2013 | <b>Construction, Operations and<br/>Maintenance Environmental Permitting<br/>and Compliance</b> | Standard Number:<br><b>HSE 4440.010</b> |
| Supersedes:<br>01/01/2012     |   | Page 5 of 8                             |

**Environmental Compliance Plan (ECP):** A NiSource Gas Distribution Company-specific document prepared and issued by the S&L Group for a specific project, in which the process is initiated by submittal of a PEIF to the S&L Group by the Project Manager. An ECP provides project specific environmental clearances, and must be received by the Project Manager before a Project can begin.

**Environmental Permits and Clearance Letters:** A permit or clearance in writing from federal, state or local regulatory agency related to one or more of the following regulatory statutes, programs or agencies:

- a. Coastal Zone Management Act (CZMA)
- b. County-specific Erosion and Sediment Control Program
- c. Clean Air Act (CAA)
- d. Clean Water Act (CWA)
  - US Army Corps of Engineers (ACOE), Section 404
  - National Pollutant Discharge Elimination System (NPDES-Section 402)
  - State Water Quality Certification (Section 401)
- e. National Historic Preservation Act (NHPA- Section 106)
- f. State Erosion and Sediment Control Program
- g. Endangered Species Act (ESA-Section 7)
- h. Toxic Substance Control Act (TSCA)
- i. National Parks and Recreation Act
- j. Wild & Scenic Rivers Act
- k. Floodplain Management (Executive Order 11988)
- l. Wetland Protection (Executive Order 11990)
- m. State Marine Resources Commission
- n. United States Forest Service

**Environmentally Sensitive Area:** An area that requires special consideration and construction techniques and/or additional erosion and sedimentation control measures. The following areas are considered environmentally sensitive:

- a. Any type of water body or stream bank;
- b. Wetlands, as defined in the Federal ACOE 1987 Manual for Delineating Wetlands;
- c. The habitats of species which have been identified as endangered or threatened under the Federal Endangered Species Act;
- d. Properties listed on, or eligible for, inclusion in the National Register of Historic



## Health, Safety and Environmental Standard

### Distribution Operations

|                               |   |   |
|-------------------------------|---|---|
| Effective Date:<br>11/01/2013 | <b>Construction, Operations and<br/>Maintenance Environmental Permitting<br/>and Compliance</b> | Standard Number:<br><b>HSE 4440.010</b> |
| Supersedes:<br>01/01/2012     |   | Page 6 of 8                             |

Places, or the National Register of Natural Landmarks, as well as areas where the construction activity crosses or is adjacent to cultural resources;

- e. National, state or local forests or parks;
- f. Designated or proposed wilderness areas, national or state wild and scenic rivers, wildlife refuges and management areas and sanctuaries;
- g. Prime agricultural lands, defined by the Department of Agriculture;
- h. Sites that are subject to use by American Indians and other Native Americans for religious purposes; and
- i. Floodplains.

**HS&E: Health:** Health, Safety and Environmental Department

**NiSource Gas Distribution (NGD):** Any of the NiSource Gas Distribution Companies, which include Columbia Gas of Kentucky, Columbia Gas of Maryland, Columbia Gas of Massachusetts, Columbia Gas of Ohio, Columbia Gas of Pennsylvania, and Columbia Gas of Virginia.

**Project Environmental Information Form (PEIF):** A NiSource Gas Distribution Company-specific document that is filled out by the Project Manager and forwarded to S&L to initiate the permitting process for a specific project. The PEIF is a way of keeping record of activities to meet the requirements of the EPA under the National Environmental Policy Act (NEPA).

**Project Manager:** Any person, either by position or function, who is responsible for ensuring that a project is completed in a manner consistent with all applicable laws, regulations, and policies. Can include but is not limited to Engineer, Construction Coordinator, or Inspector.

**S&L:** Survey and Land Department

## 7. REFERENCES

### 7.1 Related Standards

- a. Environmental Construction Standard (ECS) HSE 4440.020
- b. Environmental Compliance Policy Statement HSE 4400.010
- c. Environmental Occurrence Reporting HSE 4400.020
- d. Environmental, Health, and Safety Regulatory Agency Inspection.



**Distribution Operations**

**Health, Safety and Environmental Standard**

|                               |   |   |
|-------------------------------|---|---|
| Effective Date:<br>11/01/2013 | <b>Construction, Operations and<br/>Maintenance Environmental Permitting<br/>and Compliance</b> | Standard Number:<br><b>HSE 4440.010</b> |
| Supersedes:<br>01/01/2012     |   | Page 7 of 8                             |

**EXHIBIT A**

**NiSource Gas Distribution Companies**

**Project Environmental Information Form**

|  |                                       |                             |                            |
|--|---------------------------------------|-----------------------------|----------------------------|
| <b>Project Name:</b>   | <b>State / County / Municipality:</b> | <b>Start / Commit Date:</b> |                            |
| <b>Project Implementer / Coordinator:</b>  | <b>Telephone No.:</b>                 | <b>Job Order No.:</b>       | <b>Field View Map No.:</b> |
| <b>Location Description:</b>   |                                       |                             |                            |
| <b>Project Description (Include total length and type of pipe and total amount of earth disturbance):</b>  |                                       |                             |                            |
| <b>Purpose / Need (Municipal project, DOT relocation, etc.):</b>   |                                       |                             |                            |
| <b>Anticipated / Scheduled Completion Date (If unknown, please notify NRP Group when project is complete):</b>   |                                       |                             |                            |
| 1. Will the work involve earth disturbance activities that exceed 5,000 sq. ft. in MD or PA; 1 acre in OH, KY or MA; or 2,500 sq. ft. (EAST of or adjacent to I-95) or 10,000 sq. ft. (WEST of I-95) in VA; thus requiring an Erosion and Sediment Control Plan? Yes ( ) No ( ) Unsure ( ) |                                       |                             |                            |
| <b>Will spoil be hauled away or replaced / used as backfill?</b>   |                                       |                             |                            |



**Distribution Operations**

**Health, Safety and Environmental Standard**

|                               |   |   |
|-------------------------------|---|---|
| Effective Date:<br>11/01/2013 | <b>Construction, Operations and<br/>Maintenance Environmental Permitting<br/>and Compliance</b> | Standard Number:<br><b>HSE 4440.010</b> |
| Supersedes:<br>01/01/2012     |   | Page 8 of 8                             |

2. Will there be any stream crossings during construction or are any streams immediately adjacent (within 50 feet, or within 200 feet in MA) to the construction work area? Yes ( ) No ( ) Unsure ( )

**List streams.**

3. Will there be any earth disturbance in a wetland or within 50 feet of a wetland or within 100 feet in MA? Yes ( ) No ( ) Unsure ( )

4. Is the project known to be located in the 100-year flood plain of a local waterway? Yes ( ) No ( ) Unsure ( )

5. Will there be any additional access roads or staging areas beyond public roads, existing access roads, or existing ROW that may involve stream or wetland crossings? Yes ( ) No ( )

6. To your knowledge, will the project affect any known environmentally sensitive areas such as: wild & scenic rivers, vernal pools, monitoring wells, historic sites, nature preserves, state or national parks or wilderness areas, wildlife refuges, management areas, or coastal management areas? Yes ( ) No ( ) Unsure ( )

7. Will the facility be hydrostatically tested, with the water being discharged to the environment? Yes ( ) No ( )

8. Do you need to undertake tree cutting? Yes ( ) No ( )

**OHIO ONLY**

9. Is your project designed for, or Capable of, Transporting Gas or Natural Gas at Pressures in Excess of One Hundred Twenty-Five Pounds per Square Inch)? Yes ( ) No ( )

**If unsure about any question, contact Distribution Engineering Services – Land and Survey for further guidance.**

**If all questions have been answered with a “No” response then the project may proceed without further review.**

**If you answered "Yes" to any of the above questions, attach a project location map (USGS Topographic map, Google Maps, FieldView) to this form. A signed and dated copy of this document shall be submitted to Anya Schrier (CPA/CMD) at [aeschrier@nisource.com](mailto:aeschrier@nisource.com), Tiffany Fritchley (COH/CKYCMA) at [tfritch@nisource.com](mailto:tfritch@nisource.com) or Lacey England (CVA) at [lengland@nisource.com](mailto:lengland@nisource.com) for project review.**

Signature: \_\_\_\_\_

Date: \_\_\_\_\_



# Health, Safety and Environmental Standard

## Distribution Operations

|                             |   |   |
|-----------------------------|---|---|
| Effective Date:<br>7/1/2014 | <b>Environmental Construction Standards</b> | Standard Number:<br><b>HSE 4440.020</b> |
| Supersedes:<br>11/01/2013   |   | Page 1 of 69                            |

Companies Affected:

|                                 |   |   |
|---------------------------------|---|---|
| <input type="checkbox"/> NIPSCO | <input type="checkbox"/> CGV            | <input checked="" type="checkbox"/> CMD |
|                                 | <input checked="" type="checkbox"/> CKY | <input checked="" type="checkbox"/> COH |
|                                 | <input checked="" type="checkbox"/> CMA | <input checked="" type="checkbox"/> CPA |

**REFERENCE**    None

### 1. INTRODUCTION

**NiSource Natural Gas Distribution Companies** (Gas Distribution) are committed to complying with the applicable environmental rules and regulations of federal, state, and local governments. It is NiSource’s goal to meet these requirements in the pursuit of a cleaner, safer environment for future operations.

Recognizing this goal, it is Gas Distribution’s practice that all construction, operation and maintenance activities be conducted in a safe manner that minimize impacts on stream and wetland ecosystems, upland ecosystems, wildlife habitat, cultural resources and the human environment. This Environmental Construction Standards (ECS) document reflects the minimum requirements to be applied to all construction, operation, and maintenance activities conducted in support of the Gas Distribution operation as outlined by federal and state agencies. Construction Projects may require permits and/or approvals from governmental authorities prior to actual construction and the ECS is not a substitute for obtaining such authorizations. Contact the NiSource Gas Distribution Survey and Land (NGD Survey and Land) Group prior to project construction for permit acquisition.

The general objective of the ECS is to provide Gas Distribution personnel and contractors with instructional information and a practical approach to environmental concerns, which can arise before, during, and after facility construction. More specific objectives include:

- a. minimize impacts to environmentally sensitive areas;
- b. use the minimum land required for safe and efficient construction, operation, and maintenance of the facilities;
- c. prevent erosion and sedimentation during construction; and
- d. complete construction in a safe and timely manner.

Words and/or phrases which have special meaning (shown in **bold** at first occurrence in text) and acronyms have been defined in Section VIII.

*This document is considered CONTROLLED only when viewed electronically on the Company’s intranet. Printed or other electronic copies may not be current, and the intranet version should be used to verify.*

|                             |  |   |
|-----------------------------|--|---|
| Effective Date:<br>7/1/2014 | <b>Environmental Construction Standard</b> | Standard Number:<br><b>HSE 4440.020</b> |
| Supersedes:<br>11/1/2013    |  | Page 2 of 69                            |

The intent of the ECS is to confine project-related disturbance to the identified **construction work areas** and to minimize erosion and enhance re-vegetation in those areas. Any project-related ground disturbance (including erosion) outside of these areas is subject to compliance with all applicable surveys. This includes all environmental and regulatory mandated surveys such as but not limited to, threatened and endangered species surveys, archeology surveys, wetland delineations, etc.

The ECS is focused primarily on pipeline related construction, operation, and maintenance. However, it can be equally applied to all natural Gas Distribution construction activities. The ECS shall be used as the base document from which the NGD Survey and Land Group will build individual project-specific Environmental Compliance Plans (ECP) where necessary. The ECP will include a written summary of requirements and recommendations from appropriate federal, state, and local agencies. Compliance with these items is required prior to and during construction. If a project specific ECP is not required, this document will provide the necessary environmental construction guidance. Federal, state, delegated county and local agencies having regulations more stringent than the ECS shall supersede those contained within this document. The ECS covers erosion and sedimentation (E&S) control plan requirements but does not address safety codes or regulations. Descriptions within do not supersede any and all applicable state or federal safety regulations.

The various Best Management Practices (**BMPs**) described herein are primarily utilized during earth disturbances associated with land development and construction activities.

BMPs, when designed according to these standards, and properly implemented and maintained, may be assumed to achieve the regulatory standard of minimizing the potential for accelerated erosion and sedimentation.

BMPs that fail after installation must be repaired to function properly or be replaced by alternative BMPs that will serve the intended purpose. Likewise, if unforeseen conditions occur on a site, and the installed BMPs are obviously not effective, then alternate BMPs must be designed and installed. The need for redesign will be determined on a case-by-case basis.

## 2. UPLAND CONSTRUCTION

### 2.1 GENERAL

This chapter describes typical upland Gas Distribution construction and Operation and Maintenance (O&M) activities.

The upland Gas Distribution pipeline construction spread usually operates as a moving assembly line performing specialized procedures in an efficient, planned sequence. In addition, special construction crews bore under roads and railroads, construct valve settings and install wetland and stream crossings.

While construction work is ongoing, the construction work area will be kept clean of all rubbish and debris resulting from the work. Non-hazardous materials and waste shall be disposed of in an approved landfill and/or recycled at an appropriate facility. Hazardous waste shall be disposed of in accordance with Gas Distribution policies and



|                             |  |   |
|-----------------------------|--|---|
| Effective Date:<br>7/1/2014 | <b>Environmental Construction<br/>Standard</b> | Standard Number:<br><b>HSE 4440.020</b> |
| Supersedes:<br>11/1/2013    |  | Page 3 of 69                            |

federal, state and local regulations.

As will be discussed in further detail in Section III, the wetland and stream Gas Distribution pipeline construction spread will be completed as a separate entity to the above referenced upland construction. Specifically, special crews will install stream and **wetland** crossings that are not done by conventional upland techniques, including the use of flumed stream crossings, pump bypass stream crossings and directional drill of either wetland or stream resources. Stream or wetland crossings of any type require federal and state agency approval. Contact the NGD Survey and Land Group prior to project construction for permit acquisition and construction clearance.

## 2.2 RIGHT-OF-WAY WIDTH

For the construction work associated with Gas Distribution pipelines (ranging from 2 to 20-inch in diameter) the permanent right-of-way (**ROW**) can range from 20 to 50 feet in width; however, it is not uncommon for the Gas Distribution pipeline to be co-located within a wider ROW. This entire ROW width may not be required for construction. A typical 30-foot ROW is illustrated in Figure 1.

If a specific width is not recorded for the ROW, the following minimum widths should apply: for pipelines six-inches or less in diameter and less than or equal to 60 psi, the ROW width should be 20 feet wide. For pipelines greater than six-inches in diameter and/or pressure greater than 60 psi, the ROW should be 50 feet wide. After the construction work area is restored, temporary work areas are allowed to revert to their previous uses. The permanent ROW is maintained as the company's permanent ROW for the facility.

In addition, there may be instances where extra work areas are needed for topsoil conservation, side hill construction, equipment staging, pipe and material storage, temporary and permanent access, and related construction activities. Such areas will be identified on project plans and considered part of the project disturbance. Gas Distribution pipelines may be constructed through confined areas; alternate construction methods may be required in narrow construction work area situations to safeguard workers, equipment, the pipeline, and the environment. Alternate construction methods shall be reviewed by the Project Manager or NGD Survey and Land Group prior to initiation.

For small diameter Gas Distribution pipeline installations, a smaller width ROW can be used (such as a 10-foot wide ROW) due to a narrow trench and the use of smaller equipment such as a ditch witch trencher, vibrating plow, or installation of pipe by hand. In many instances, these smaller diameter pipes will be installed within the construction area limited to that public ROW. Figure 2 illustrates the typical pipeline construction work area for paralleling existing facilities, such as roadside construction.

## 2.3 ROADSIDE OR IN-ROAD CONSTRUCTION

When a pipeline is being constructed parallel to a public or private roadway; or, within or adjacent to the public ROW, a primary concern is controlling runoff pollution from leaving the work site and reaching surface waters.



|                             |  |   |
|-----------------------------|--|---|
| Effective Date:<br>7/1/2014 | <b>Environmental Construction<br/>Standard</b> | Standard Number:<br><b>HSE 4440.020</b> |
| Supersedes:<br>11/1/2013    |  | Page 4 of 69                            |

Appropriate BMPs should be installed prior to the start of the earth disturbance activity to effectively limit the entry of pollutants into surface waters both during and after construction.

### **2.3.1 Inlet Protection**

For typical roadside or in-road construction, primary concern is given to the protection of storm water collection basins present within the work area. An inlet filter bag (Figure 3) shall be installed prior to the start of work to prevent soil and sediment from entering the storm sewer system. Inlet filter bags are recommended for protection of the curb inlets. These controls are designed to fit inside the inlet opening and filter runoff as it passes through the inlet opening. Inlet filter bags shall be installed according to the manufacturer's specifications.

Stone inlet protection is also an option for those structures that are not flush with the road surface. A layer of mesh or filter fabric creates a barrier between the inlet opening and the stone to allow for the passage and treatment of runoff. Inlet protection shall be maintained and cleaned out or replaced when the bag is half full or when flow capacity has been reduced. Care should be taken to prevent ponding on roadways. Accumulated sediment shall be disposed of in the approved manner. Damaged filter bags or inlet protection shall be replaced immediately.

### **2.3.2 Perimeter Control**

Where feasible, sediment barrier BMPs should be installed around the perimeter of a disturbed area to prevent sediment from leaving the work area. While it may not be practical in all instances to install perimeter controls around construction taking place within or adjacent to the roadway, they should be included where possible. Refer to Figure 4 for the proper alignment of sediment barriers on the work site. Compost filter socks (Figure 5) are an effective way of controlling sediment from leaving the work site. Compost filter socks can easily be installed downslope of any work areas (where feasible) or around spoil piles both within or adjacent to the roadway. Depending on the site characteristics, filter fabric fence (Figure 6), straw bale barriers (Figure 7), or straw wattles (Figure 8) may also be used as perimeter controls.

In areas where perimeter controls are not feasible, all erodible surfaces should be stabilized at the end of each work day. This will include the placement of mulch or covering the area with an erosion control blanket or plastic sheeting.

### **2.3.3 Dewatering Work Areas**

The proper disposal of water within the work area is also a primary concern during construction. Water impounded in the trench or bore pits shall not be released directly or by overland flow into any waterbody or wetland. Whenever water is pumped from an excavation, it must be treated for sediment removal prior to discharge into a surface water or storm sewer system. If it is necessary

|                             |  |   |
|-----------------------------|--|---|
| Effective Date:<br>7/1/2014 | <b>Environmental Construction<br/>Standard</b> | Standard Number:<br><b>HSE 4440.020</b> |
| Supersedes:<br>11/1/2013    |  | Page 5 of 69                            |

to remove water from the trench or bore pits, a pumped water filter bag (Figure 9) shall be used. Bags shall be located in a well-vegetated area (where available) and discharge into a stable, erosion-resistant area. Additional requirements for the proper use of this control are outlined on Figure 9.

For greater dewatering capacity, pumped water could be discharged to a sediment trap (Figure 10) or compost sock sediment trap (Figure 11). Care should be taken to monitor and regulate the flow of water into the sediment trap; at no time should the pumped water overflow the sediment trap.

#### **2.3.4 Protect Existing Features**

Vegetated areas are very effective sediment filters. Where feasible, retaining vegetative cover within the project area can help to reduce the volume of sediment leaving the site.

When a roadside ditch or drainage channel/swale is present (parallel or perpendicular) to the construction activity, sediment filter devices must be put into place where needed to prevent sediment from entering a waterway via the ditch. Compost filter socks (Figure 5) or rock filters (Figure 12) should be installed in the ditch to reduce runoff velocity and collect sediments that have entered the ditch during a runoff event. Filter fabric fence and straw bale barriers are not appropriate for these areas of concentrated flow.

#### **2.3.5 Construction Entrances**

Stabilized construction entrances are necessary to minimize off-site tracking of sediment. A stabilized entrance may not be required during roadside or in-road construction if the activity takes place within the roadway or access to the activity is directly from the roadway. However, if construction traffic will be accessing a paved road directly from a disturbed area, a Rock Construction Entrance (Figure 13) should be installed at every point where vehicles enter or exit the site.

#### **2.3.6 Operation and Maintenance**

Inspection and maintenance of erosion and sediment control BMPs both during and after construction is important to ensure that the BMPs are operating properly and effectively.

During construction, maintenance will include inspection of all E&S control devices near the end of each work day or after any runoff/rain event. All preventative and remedial maintenance work, including BMP clean out, repair, and replacement, will be performed before leaving the project site for the day.

Sediment, sawed-out slurry, or broken asphalt/concrete should be removed from the site regularly. This material should be removed using a shovel or vacuum and hauled from the site. Under no circumstances should this material be swept or washed into storm water inlets within or adjacent to the

|                             |  |   |
|-----------------------------|--|---|
| Effective Date:<br>7/1/2014 | <b>Environmental Construction<br/>Standard</b> | Standard Number:<br><b>HSE 4440.020</b> |
| Supersedes:<br>11/1/2013    |  | Page 6 of 69                            |

construction area.

The on-site Environmental Inspector is responsible for conducting the regular inspections of BMPs and for directing any required maintenance that is to be performed by the crews or construction contractor.

Written documentation of the findings of each inspection will be kept on-site and available for review at any time. Inspections will continue after construction has been completed, until disturbed areas have been stabilized and restored with uniform 70% perennial vegetative cover.

### 2.3.7 Site Stabilization

As soon as disturbed areas reach final grade they must be stabilized. Areas that have significant potential for erosion should be stabilized with vegetation. Recommended seed mixtures for vegetative stabilization can be found in Table 1.

In areas where earth disturbance activity has temporarily ceased, temporary stabilization shall be completed as soon as possible, but at least within four days. Areas that will be subject to earthmoving within 12 months may be stabilized with temporary seed mixtures. Graded areas where it is anticipated that future earth disturbance will take place (i.e. bare dirt areas along the mainline where service line installation is planned) can be stabilized with an erosion control blanket (Figure 14).

When final grade is achieved during non-germinating months, the disturbed area should be mulched until the beginning of the next planting season. Critical areas (highly erodible soils, within 50 feet of a surface water, etc.) should be stabilized with an erosion control blanket.

The area will not be considered stabilized until a minimum uniform 70% vegetative cover of erosion resistant perennial species has been achieved. Temporary erosion control BMPs must remain in place and be maintained in working order until permanent stabilization is achieved.

## 2.4 CLEARING

When work is necessary outside of a previously cleared and maintained public ROW, the construction work area will be cleared to the width specified in the ROW agreements, E&S control plan, or ECP, whichever is less. During clearing operations, all brush and trees will be felled into the construction work area to prevent off-construction work area damage to trees and structures. Large or valuable trees may be retained, provided they will not interfere with the construction, operation, or maintenance of the facility. These trees shall be marked in a manner that allows construction to continue but keeps the trees protected (e.g., ribbons and/or safety fencing).

Temporary erosion and sedimentation controls (as described in Section E-3)

|                             |  |   |
|-----------------------------|--|---|
| Effective Date:<br>7/1/2014 | <b>Environmental Construction<br/>Standard</b> | Standard Number:<br><b>HSE 4440.020</b> |
| Supersedes:<br>11/1/2013    |  | Page 7 of 69                            |

should be installed and functioning properly prior to clearing activities.

#### 2.4.1 Wood Products

Wood Products (saw logs, pulpwood, or cordwood) will revert to the landowner unless otherwise specified. Wood products should not be used for any purpose unless written permission is first obtained from the landowner. When the landowner requests salvage of these materials, they shall not be stockpiled within floodplains or wetlands.

#### 2.4.2 Brush

All cleared brush can be disposed of by one of the following methods:

- a. Brush may be piled at the edge of the construction work area but not within 50 feet of streams, floodplains or wetlands. Equipment stacking the brush should not leave the construction work area. Brush piles will be constructed approximately 12 feet wide and compacted to approximately 4 feet high, with periodic breaks at a minimum of every 200 feet to permit wildlife travel. The landowner should be consulted to determine acceptable brush pile locations along the construction work area.
- b. Brush may be burned where permitted by law. The necessary burning permits must be obtained prior to burning. Fires will be of reasonable size and located and patrolled so that they will not spread off the construction work area.
- c. The brush may be chipped and given away, buried, thinly spread (less than 2 inches thick) over the construction work area, or blown off the construction work area (per documented landowner agreement) except in **agricultural lands** or within streams, floodplains, or wetlands. Chipping will be limited to those areas where agreed to with the landowner. During **restoration**, soil will be augmented by the addition of 12 to 15 pounds of nitrogen per ton of chips to aid re-vegetation. Follow the guidance contained in Section J for restoration and re-vegetation guidelines.

### 2.5 GRADING

Grading is necessary to provide a smooth and even surface for safe and efficient operation of construction equipment. Grade the minimum amount necessary; temporary E&S controls such as waterbars and **sediment filter devices** should be installed and functioning properly prior to grading activities.

#### 2.5.1 Tree Stump and Rock Removal and Disposal

Tree stumps and large rocks can be cut, graded or removed as necessary to permit construction and to provide adequate clearance for mechanical equipment and other vehicles. Tree stumps that are adjacent to roads will be

|                             |  |   |
|-----------------------------|--|---|
| Effective Date:<br>7/1/2014 | <b>Environmental Construction<br/>Standard</b> | Standard Number:<br><b>HSE 4440.020</b> |
| Supersedes:<br>11/1/2013    |  | Page 8 of 69                            |

cut close to the ground (flush cut) or removed.

Stumps and large rocks will be disposed of in one of the following approaches:

- a. as allowed by state, county or local regulatory agencies, buried within the construction work area except in agricultural, residential, or wetland areas;
- b. windrowed just off the edge of the construction work area with landowners' permission. Windrows will not be located within streams, floodplains, or wetlands;
- c. hauled from the site and disposed of in an approved landfill or other suitable area.

### 2.5.2 Topsoil Conservation

Unless the landowner or land management agency specifically approves otherwise, prevent the mixing of topsoil with subsoil by stripping topsoil from either the full work area or from the trench and subsoil storage area (ditch plus spoil side method) in:

- a. actively cultivated or rotated croplands and pastures;
- b. residential areas;
- c. hayfields; and
- d. other areas at the landowner's or land managing agency's request.

In deep soils (more than 12 inches of topsoil), segregate at least 12 inches of topsoil. In soils with less than 12 inches of topsoil make every effort to segregate the entire topsoil layer. Segregated topsoil may not be used for padding the pipe. Figure 15 illustrates topsoil conservation techniques.

The topsoil will be stockpiled separately from all subsoil and will be replaced last during backfilling and **final grading**.

In residential areas, topsoil replacement (i.e., importation of topsoil) is an acceptable alternative to topsoil segregation.

### 2.5.3 Erosion Control Devices Installed During Grading

Temporary erosion controls will be installed prior to the initial disturbance of soil where required. Erosion control devices are illustrated in Figures 5 through 11.

All temporary erosion control devices, including roadside ditches, will be inspected near the end of each work day or after each storm (runoff) event of 1/2 inch or greater to ensure proper functionality. Any devices damaged beyond functioning will be repaired or replaced **promptly**.

|                             |  |   |
|-----------------------------|--|---|
| Effective Date:<br>7/1/2014 | <b>Environmental Construction<br/>Standard</b> | Standard Number:<br><b>HSE 4440.020</b> |
| Supersedes:<br>11/1/2013    |  | Page 9 of 69                            |

The following erosion control devices are suitable for temporary erosion and sedimentation control for implementation before or immediately following clearing and grading operations:

- a. Compost Filter Sock (Figure 5) may be used to control runoff from small disturbed areas or steep slope areas where runoff is in the form of sheet flow. Compost filter socks are an efficient and easy to maintain control and must be installed according to the specifications in Figure 5. As with other sediment barriers, filter socks should be placed parallel to contour with both ends of the sock extended upslope at a 45 degree angle to the rest of the sock to prevent sediment from traveling around the ends (as shown in Figure 4). Socks placed on earthen slopes should be anchored with stakes driven through the center of the sock or immediately downslope of the sock at intervals recommended by the manufacturer. Where socks are placed on paved surfaces, concrete blocks should be used immediately downslope of the socks (at the same intervals recommended for the stakes) to help hold the sock in place. Upon stabilization of the work area, the filter sock may be left in place and vegetated or removed. In the latter case, the mesh is typically cut open and the compost spread as a soil supplement. In either case, the stakes should be removed. Refer to Table 3 for filter sock fabric and compost specifications.
- b. Filter Fabric Fence (Figure 6) may be used to control runoff from small disturbed areas or short-slope disturbed areas when runoff is in the form of sheet flow and the discharge is to a stable area. The filter fabric fence must be installed according to the specifications outlined in Figure 6, including uniform anchoring in the soil. Silt fence should not be installed on uncompacted fills or in extremely loose soils, since this will likely result in undermining of the fence.
- c. Straw Bale Barriers (Figure 7) may be used to control runoff from small disturbed areas where runoff is in the form of sheet flow. Straw bales tend to deteriorate within 3 months of installation and should be considered a short-term control measures.
- d. Straw Wattle or Sediment Filter Logs (Figure 8) may be used in place of filter fabric fence in areas where the installation of filter fabric fence is not feasible due to shallow bedrock. Straw wattles shall be placed in a two to five foot trench depending on slope gradient and soil type. Runoff must not be allowed to run under or around the wattles.

Rock filters (Figure 12 or a NGD Survey and Land Group approved equivalent alternative) are considered temporary erosion controls. Curb inlet protection devices (Figure 3), if required, will be installed at this time. In areas of concentrated flow, a rock filter outlet (Figure 16) should be used as an alternative to silt fence or straw bales. Refer to Section II. C for typical erosion control installation during roadside construction.



|                             |  |   |
|-----------------------------|--|---|
| Effective Date:<br>7/1/2014 | <b>Environmental Construction<br/>Standard</b> | Standard Number:<br><b>HSE 4440.020</b> |
| Supersedes:<br>11/1/2013    |  | Page 10 of 69                           |

#### **2.5.4 Waterbars or Interceptor Diversions**

Waterbars (Figure 17) are a common and effective device used for erosion control on construction ROW. During construction, temporary waterbars are installed to control water on the graded ROW. During restoration, permanent waterbars are installed to protect the ROW from erosion until vegetation becomes reestablished on the disturbed areas.

Temporary diversions are generally made by building a curb 8 to 14 inches high across the ROW. The curbs are shaped to allow passage of construction equipment and inspector vehicles. The diversion should have a gradient of 2% to 12% and must drain either into the trench or off of the ROW. Where water is directed off the ROW, the outlet will be protected by a sediment filter device or heavy vegetation. Temporary diversions may be broken down by construction equipment during the workday, but will be restored by the end of each day. Temporary diversions will be spaced along the ROW in accordance with Figure 17. The actual number of temporary waterbars may vary from that of permanent waterbars due to change in slope after the completion of construction and final grading. Position the outfall of each waterbar to prevent sediment discharge into wetland, waterbodies, or other sensitive areas.

Permanent waterbars typically consist of a curb 16 to 24 inches high below a shallow swale. The curb is constructed of compacted earth fill with side slopes of 2:1 or flatter to allow passage of maintenance equipment. The diversions should extend across the entire ROW and drain water with a 2% to 12% gradient. The outlets of final diversions are stabilized with sediment filter devices, rock, brush, or heavy vegetation. Final diversions will be spaced along the ROW in accordance with Figure 17 and will tie into existing waterbars where present. In places where final grade creates side slopes or slopes which break in more than one direction, waterbar installation may need to vary to create an outslope of 2% to 12% which will carry water off the ROW.

#### **2.5.5 Rock Construction Entrances**

Rock Construction Entrances, as illustrated in Figure 13, shall be installed where the construction work area crosses public roads or where construction traffic will exit onto a roadway, public or private. The rock construction entrances are needed to maintain safe vehicle operation and to prevent tracking soil and mud onto public roads. These installations are designed to remove mud from vehicle tires and tracks before accessing the road. Access to the site should be limited to the stabilized construction entrance(s). At a minimum, the rock construction entrance should be constructed to the dimensions shown on Figure 13.

At temporary road entrances, geotextile fabric should be used as illustrated in Figure 13. The underlying bed of the entrance area should be cleared of small stumps and protruding organic material as these tend to puncture the fabric; thereby allowing fine soil particles to mix with the gravel. At existing gravel access roads the rock construction entrance does not have to be underlain with

|                             |  |   |
|-----------------------------|--|---|
| Effective Date:<br>7/1/2014 | <b>Environmental Construction<br/>Standard</b> | Standard Number:<br><b>HSE 4440.020</b> |
| Supersedes:<br>11/1/2013    |  | Page 11 of 69                           |

geotextile fabric.

In addition, public roads will be swept, shoveled or scraped as necessary to keep the road surface safe. Washing the roadway or sweeping the deposits into roadway ditches, sewer, culverts, or other drainage ways is not acceptable. If no access is required onto the roadway, the installation of a rock construction entrance is not required; however, safety fencing should be installed across the ROW and signs designating “no entrance” can be erected to avoid any unintentional entrances.

## 2.6 ACCESS ROADS

Typically, access roads to the Gas Distribution pipeline system already exist. All public roads are available for use as access roads without further environmental review. However, all private access roads intended for use are subject to applicable environmental reviews. Safe and accessible conditions will be maintained at all roadway crossings and access points during construction and restoration activities.

New access roads will be built only if existing access is inadequate. The access roads will be a maximum of 25 feet wide with additional width in tight turns and at intersections with public roads. The roads will either be temporary (used for access during construction only) or permanent (used during and after construction for operation and maintenance of the facilities). Again, safe and accessible conditions will be maintained at all roadway crossings and access points during construction and restoration.

Access road gradient will be as flat as local topography will practically allow. By breaking or changing grade frequently, fewer erosion problems will be encountered than on long, straight, continuous gradients. Waterbars (interceptor diversions or slope breakers) and/or other sediment control devices will be installed as needed.

Road crossings of streams and wetlands require special environmental construction standards as described in Section III. Roads will cross streams and wetlands as close as possible to right angles. Road gradients approaching these crossings will be graded to decrease runoff velocity. Runoff will be dispersed just prior to the crossing by means of an interceptor diversion with a sediment filter device at the outlet. Where conditions permit, new roads will be located at least 25 feet from any stream or wetland except at crossing locations. Culverts will be appropriately sized and placed to permit water flow under the access road.

After construction, temporary access roads (including any additional width used for construction) can be graded and left intact for the landowner’s benefit or removed and the area restored using the same specifications as applied to the construction work area.

## 2.7 RESIDENTIAL AND COMMERCIAL AREAS

The following mitigation measures should be implemented for all residences and businesses within 50 feet of the construction work area:



|                             |  |   |
|-----------------------------|--|---|
| Effective Date:<br>7/1/2014 | <b>Environmental Construction<br/>Standard</b> | Standard Number:<br><b>HSE 4440.020</b> |
| Supersedes:<br>11/1/2013    |  | Page 12 of 69                           |

- a. Timely notification of required construction activities to ensure safe access and maneuverability;
- b. Minimize disturbance to existing maintained areas by ensuring proper spoil pile placement;
- c. While the trench is open, the edge of the construction work area adjacent to the residence or business will be safety fenced for a distance of approximately 100 feet on either side of the residence to ensure safety within the construction work areas;
- d. In a timely manner after backfilling the trench, all lawns will be restored to final restoration or temporary restoration pending weather and soil conditions.

## 2.8 TRENCHING

### 2.8.1 Trenching Specifications

The total length of excavated trench open at any one time should not be greater than the total length of utility line that can be placed in the trench and backfilled in one working day. Additional restrictions for stream and wetland areas are provided in Section III. Spoil shall be placed at least two (2) feet from the edge of the trench.

- a. Sediment filter devices will be installed before excavating bore pits, and before constructing stream and wetland crossings.
- b. As the trench is completed, trench breakers (as illustrated in Figure 18) will be installed at a maximum spacing of 1,000 feet and as specified in the drawing. Trench breakers reduce water velocity along the pipeline bedding and result in less erosion/scour of the trench bottom. They shall be installed at all stream, waterbody and wetland crossings regardless of slope. Topsoil will not be used to construct the trench breakers.
- c. Water impounded in the trench will not be released directly or by overland flow into any waterbody or wetland. If it is necessary to remove water from the trench or bore pits, a Pumped Water Filter Bag (Figure 9) should be used. Bags should be located in a well-vegetated (grassy) area and discharge into a stable, erosion-resistant area. A suitable means of accessing the bag with machinery required for disposal purposes shall be provided. Bags shall be placed on straps to facilitate removal unless bags come with lifting straps already attached. Additional requirements are outlined on Figure 9. For greater dewatering capacity, pumped water could be discharged to a sediment trap (Figure 10) or compost sock sediment trap (Figure 11). Care should be taken in order to minimize erosion and subsequent sedimentation of streams or wetlands by monitoring and regulating the flow of water into the sediment trap. At no time should the pumped water overtop the

|                             |  |   |
|-----------------------------|--|---|
| Effective Date:<br>7/1/2014 | <b>Environmental Construction<br/>Standard</b> | Standard Number:<br><b>HSE 4440.020</b> |
| Supersedes:<br>11/1/2013    |  | Page 13 of 69                           |

sediment trap.

When conditions dictate that the trench must remain open for a greater length of time than anticipated, appropriate erosion controls and safety measures will be employed as directed by the **Inspector**.

### 2.8.2 Blasting

All drilling and blasting will be completed in accordance with the rules and permits issued by the overseeing regulatory agency. Areas requiring blasting to adequately cover the pipeline shall be identified to the extent practicable before construction commences. No blasting shall occur in upland areas until appropriate regulatory permits have been issued; or until the NGD Survey and Land Group has indicated that none are required. All required precautions will be taken to avoid injury or damage to persons, livestock, environment, or other property.

### 2.8.3 Temporary Construction Access Over the Trenchline

Where access across the trenchline is required, temporary facilities such as wooden mats or steel plates will be constructed or installed to permit safe crossing of livestock, vehicles, equipment, and persons from one side of the trench to the other.

### 2.8.4 Directional Bore in Upland Areas

Directional bore is often used as an alternative to open trench construction when working within or adjacent to the roadway or within residential areas.

During the directional bore process an **inadvertent release of drilling fluid** may occur. An inadvertent release of drilling fluid occurs when the bore fluid seeps to the surface through cracks or voids in the soil. In the event of an inadvertent release of drilling fluid occurring in an upland area, the following inadvertent release of drilling fluid contingency plan procedures will be followed.

1. The source/pumps will be stopped temporarily or the pressure will be decreased;
2. The inadvertent release of drilling fluid will be contained immediately by installing straw bales, compost filter sock or equivalent.
3. The drilling mud will be removed from the site to the greatest extent possible by manual means such as by use of shovels, wheelbarrows and/or vacuum hoses. If these methods are unsuccessful, contact the NGD Survey and Land Group for your area.
4. The affected areas will be restored as closely as possible to their previous condition.

|                             |  |   |
|-----------------------------|--|---|
| Effective Date:<br>7/1/2014 | <b>Environmental Construction Standard</b> | Standard Number:<br><b>HSE 4440.020</b> |
| Supersedes:<br>11/1/2013    |  | Page 14 of 69                           |

5. Documentation (including date, time, weather conditions, approximate volume and photographs) must be made and provided to the NGD Survey and Land Group as soon as possible.
6. Any special instructions from the Project Manager or NGD Survey and Land Group must be followed.
7. Once the inadvertent release of drilling fluid has been contained the boring process may continue. Typically, drilling activities will not be suspended unless the inadvertent release creates a threat to public health and safety or unless suspended by the Project Manager or NGD Survey and Land Group.

## 2.9 BACKFILLING SPECIFICATIONS

Backfilling will follow pipe installation as closely as practical using the excavated subsoil or imported material suitable for backfill operations in accordance with Gas Standard GS 3010.050. Topsoil will not be used to pad the pipe. Soil that has been excavated during construction and not used for backfill will be evenly spread over the construction work area or removed from the site and properly disposed. All waste materials such as barrels, cans, drums, stumps, coating and wrap, rubbish, waste, or other refuse will not be placed in the trench, but removed from the construction area and disposed of at appropriate facilities.

Trench breakers (Figure 18) will be placed in the trench prior to backfilling to prevent water movement and subsequent erosion. Trench breakers shall be installed at the spacing illustrated in the figure, up-slope of any permanent waterbars and at all stream, waterbody, and wetland crossings.

Excess excavated rock, including blast rock with a dimension not larger than six inches may be returned to the trench, but care should be used to prevent damage to the pipe or coating.

## 2.10 FINAL GRADING, RESTORATION AND STABILIZATION

Upon completion of construction activities, all disturbed areas will be stabilized with final grading and restoration. In the case where final grading and restoration is not immediately feasible, **temporary stabilization** measures (to prevent erosion and sedimentation until final grading and restoration can be completed) are required.

### 2.10.1 Final Grading

Final grading should be completed within 14 calendar days of backfilling, weather and soil conditions permitting. When conditions require a delay, the 14-day time frame will not start until conditions are suitable for grading. If unsuitable soil conditions are expected to persist for more than 21 calendar days, the Inspector will record the conditions and require the installation of temporary stabilization measures, and final grading and restoration will be delayed. In no case shall final grading be delayed beyond the end of the next recommended seeding season.

|                             |  |   |
|-----------------------------|--|---|
| Effective Date:<br>7/1/2014 | <b>Environmental Construction<br/>Standard</b> | Standard Number:<br><b>HSE 4440.020</b> |
| Supersedes:<br>11/1/2013    |  | Page 15 of 69                           |

Segregated and conserved topsoil will be returned to the ROW during final grading.

If final grade can be established but conditions are not ideal for permanent seeding, the Inspector will specify application of temporary stabilization measures and may also consider concurrent application of final seed mix and mulch (as provided in Table 1, or per the seasonal recommendation of the local or county soil conservation service/authority). Temporary stabilization measures may consist of mulching or temporary seeding covered by mulch. These measures should be implemented on a ground surface prepared by surface roughening, grooving, or tracking slopes as with permanent stabilization. Temporary erosion control BMPs must remain in place and be maintained in working order until permanent stabilization is achieved.

During final grading, soil over the trench may be mounded to allow for future settling. Where fill in the trench or major depressions have settled below ground level, additional fill will be added as needed and the area brought to final grade.

Excess rock will be removed from at least the top 12 inches of soil to the extent practicable in all rotated and permanent agricultural land, hayfields, pastures, residential areas, and other areas at the landowner's request. The size, density and distribution of rock on the construction work area should be similar to adjacent areas not disturbed by construction.

Final erosion control devices (filter fabric fence, straw bale barrier, interceptor diversion/slope breakers) will be installed during final grading. Sediment filter devices needed to protect off-construction work area resources will be installed or rebuilt promptly after final grading. Final interceptor diversions will not be installed in agricultural or pastureland without landowner's consent.

### **2.10.2 Soil Compaction Testing**

Where required by the appropriate agency, test topsoil and subsoil for compaction at regular intervals in agricultural and residential areas disturbed by construction activities. Conduct tests on the same soil type under similar moisture conditions in undisturbed areas to identify approximate preconstruction conditions. Use penetrometers or other appropriate devices to conduct tests.

Plow severely compacted agricultural areas. In areas where topsoil has been segregated, plow the subsoil before replacing the segregated topsoil. Alternatively, make arrangements with the landowner to plant and plow under a "green manure" crop such as alfalfa to decrease soil bulk density and improve soil structure. If subsequent construction and cleanup activities result in further compaction, conduct additional tilling.

Perform appropriate soil compaction mitigation in severely compacted residential areas. Soil compaction testing of subsoil and topsoil may also be

|                             |  |   |
|-----------------------------|--|---|
| Effective Date:<br>7/1/2014 | <b>Environmental Construction<br/>Standard</b> | Standard Number:<br><b>HSE 4440.020</b> |
| Supersedes:<br>11/1/2013    |  | Page 16 of 69                           |

required in some roadways.

### 2.10.3 Restoration

As soon as disturbed areas reach final grade they must be stabilized. All disturbed areas that have not otherwise been stabilized and have significant potential for erosion should be stabilized with vegetation. This includes graded areas where it is anticipated that future earth moving will take place within the coming year. Areas that will be subject to earthmoving within 12 months may be stabilized with temporary seed mixtures, predominantly annual grasses. The area will be considered stabilized when a minimum 70% vegetated cover of erosion resistant perennial species has been achieved.

As disturbed areas within a project approach final grade, preparations should be made for seeding and mulching to begin (i.e. anticipate the completion date and schedule the seeder). In no case should an area exceeding 15,000 square feet, which is to be stabilized by vegetation, reach final grade without being seeded and mulched. Before the seeding begins, topsoil should be applied and any required soil amendments worked into the soil to a depth of 4 to 6 inches.

All seeded areas should be mulched or blanketed to minimize the potential for failure to establish an adequate vegetative cover. The recommended seed mixtures and typical application rates for lime, fertilizer, and mulch in upland areas are listed in Tables 1 and 2. These specifications will be used unless the ROW agreement, permit, or local Natural Resource Conservation Service (NRCS) provides project-specific recommendations.

An erosion control blanket (Figure 14) or equivalent approved by the Inspector may be used on **steep slopes** to help stabilize the construction work area.

If sod is to be used, install as outlined below.

#### a. Site Preparation

- Install water control (subsurface irrigation) measures as applicable.
- Loosen soil surface to a depth of one inch with a shallow tillage tool and dampen soil before laying sod.

#### b. Selection

- Select sod grown from seed of adapted varieties and under cultural practices conducive to high quality sod that will be free of any serious thatch, weeds, insects, diseases, and other pest problems.
- Select species and varieties best suited for the sites to be planted and the purpose for which the turf will be used. The type of sod should be composed of plants adapted to

|                             |  |   |
|-----------------------------|--|---|
| Effective Date:<br>7/1/2014 | <b>Environmental Construction<br/>Standard</b> | Standard Number:<br><b>HSE 4440.020</b> |
| Supersedes:<br>11/1/2013    |  | Page 17 of 69                           |

the site conditions (dry or wet, full sun or shade, gentle slopes or steep, etc.).

- Select sod at least one year old, but less than three years. Cultivated turfgrass is usually considered ready for harvest when a cut portion of sod three feet in length and approximately half a foot in width will support its own weight. The most common age of sod when cut is 15 to 24 months.
- Select sod cuts of width and length suited to the equipment and job. Generally, sod cuts are 12 to 24 inches in width with 12 inches being the most common width. The length of cut varies from four to eight feet. Sod may be cut and rolled or folded in the middle and stacked on pallets. Folded sod is cut shorter than rolled sod, about three to four feet in length. Sod should be cut with a half to one inch layer of soil attached. The thinner the sod is cut (one-half to three-fourths of an inch), the more quickly it will knit to the site soil. About 80% of all rhizomes are in the top three-fourths of an inch of soil.
- Deliver sod to the site as soon as practical after lifting. During hot weather, delivery should be made within six hours. For best results, sod should not be moved during cold seasons or during July and August. If moved during those periods, sod may need to be cut a quarter inch thick and will require extensive care.

c. Laying Sod

- Lay strips of sod at right angles to direction of slope or flow of water starting at the lowest elevation. Wedge the edges and ends of the sod strips together and tamp or roll. Stagger joints and make the top of the sod strips flush with the surface of the undisturbed ground.
- Use wire staples, fine mesh wire or wood pins and binder twine on very steep slopes to hold sod in place until secured in plant growth.
- After the first growing season, the sod should be inspected to determine if additional fertilization or liming is needed.

**2.10.4 Temporary Stabilization**

In areas where earth disturbance activity has temporarily ceased, temporary stabilization shall be completed as soon as possible, but at least within four days. Areas that will be subject to earthmoving within 12 months may be stabilized with temporary seed mixtures, predominantly annual grasses. When final grade is achieved during non-germinating months, the areas should be mulched until the beginning of the next planting season. Temporary erosion control BMPs must remain in place and be maintained in working order until permanent stabilization is achieved. The seeding and mulching rates for



|                             |  |   |
|-----------------------------|--|---|
| Effective Date:<br>7/1/2014 | <b>Environmental Construction<br/>Standard</b> | Standard Number:<br><b>HSE 4440.020</b> |
| Supersedes:<br>11/1/2013    |  | Page 18 of 69                           |

temporary stabilization are provided in Table 2 . Consideration will be given to the following when determining if temporary stabilization measures are to be implemented:

- a. If work has temporarily or permanently ceased in a portion of the construction area and will not occur for at least four days;
- b. anticipated weather conditions; and
- c. resources on and off the construction work area to be protected.

If temporary stabilization measures are utilized, final grading and/or restoration must commence once weather and soil conditions permit.

## 2.11 NOISE IMPACT MITIGATION

Construction equipment will be properly muffled and maintained to avoid producing excessive noise near **noise sensitive areas**. Construction hours will be consistent with local or county ordinances, except in emergency construction situations.

## 2.12 HYDROSTATIC AND AIR TESTING

Typically, Gas Distribution verifies a facility's integrity by air or nitrogen testing, which is pumped into the line, held at pressure for a given time and then released to the atmosphere.

On occasion, facility integrity can be verified using hydrostatic testing. Water will be drawn from local sources (streams, ponds, public water supplies) in a manner that will minimize impacts to the environment and other existing users while maintaining adequate stream flow. The withdrawal and/or discharge of hydrostatic test water requires permit approval to be obtained prior to such activities.

Water from state designed **high quality streams** or **exceptional value waters**, waterbodies which provide habitat for federally listed threatened or endangered species, or streams utilized as public water supplies will not be used unless other water sources are not readily available and the appropriate federal, state or local agency permits its use. If test headers must be installed within 50 feet of streams and wetlands, additional sediment filter devices may be installed to prevent sediments from entering into the stream or wetland during discharge.

Comply with all approval/permit conditions which may include notifying the appropriate state agency of withdraw/discharge and collection of samples in accordance with permit conditions where required. Intake hoses will be screened.

The discharge of the hydrostatic test water will be performed in a manner that minimizes erosion. The energy of the released test water will be dissipated by discharging the water:

- a. into a well-vegetated upland area;

|                             |  |   |
|-----------------------------|--|---|
| Effective Date:<br>7/1/2014 | <b>Environmental Construction<br/>Standard</b> | Standard Number:<br><b>HSE 4440.020</b> |
| Supersedes:<br>11/1/2013    |  | Page 19 of 69                           |

- b. into a tank(s), or
- c. through sediment filter devices or sediment trap (Figures 9 and 10) to filter out various particulate matter prior to soil infiltration.

Regulate the water discharge rate, and if necessary use energy dissipation device(s), and/or install sediment barriers to prevent erosion, streambed scour, suspension of sediments, or excessive stream flow. During the discharge, the Inspector must ensure that erosion and sedimentation are properly controlled.

Do not discharge into waters from state designated exceptional value waters, waterbodies which provide habitat for federally listed threatened or endangered species, or streams utilized as public water supplies unless an authorized federal, state or local agency permit has been issued.

This guidance is for hydrostatic testing of new pipe. Permitting requirements associated with hydrostatic testing of used pipe can be extensive. Contact the NGD Survey and Land Group prior to testing any used pipe.

### 3. STREAM AND WETLAND CROSSINGS

#### 3.1 STREAM CROSSINGS

##### 3.1.1 General

In-stream work, stream crossings, and earth disturbance within 50 feet of a stream require permit authorization. Contact the NGD Survey and Land Group prior to any work within or adjacent to a waterbody.

The main objective of any waterbody crossing is to construct the pipeline in a manner which minimizes erosion and subsequent sedimentation into the waterbody. Crossings will be constructed as close as possible to right angles with the waterbody channel. Adequate downstream flow rates will be maintained at all times to protect aquatic life and prevent the interruption of existing downstream uses. Each waterbody crossing will be treated as a separate construction entity, such that construction of culverted access roads, flumes, trenching, pipe installation, backfilling, and temporary stabilization or final restoration are completed in the minimum number of consecutive calendar days possible.

Construct stream crossings during the time windows designated by the appropriate permitting agency. If there are no time of year restrictions, conduct stream crossings during low flow periods, normally July through September. When work in a live watercourse is performed, precautions shall be taken to minimize encroachment, control sediment transport and stabilize the work area to the greatest extent possible during construction.

Directional Boring can be done any time throughout the year unless specifically restricted by a state agency; however, these activities require permit



|                             |  |   |
|-----------------------------|--|---|
| Effective Date:<br>7/1/2014 | <b>Environmental Construction<br/>Standard</b> | Standard Number:<br><b>HSE 4440.020</b> |
| Supersedes:<br>11/1/2013    |  | Page 20 of 69                           |

authorization. Contact the NGD Survey and Land Group prior to any work within or adjacent to a waterbody.

When water levels are temporarily high, the Inspector will direct that the commencement of any waterbody crossing construction activities be postponed until water levels subside.

Any extra work areas will be located at least 50 feet away from the water's edge (except in agricultural fields and previously disturbed sites) where topographic conditions permit and will be limited to the size needed to construct the crossing. If topographic conditions do not permit a 50-foot setback, these areas must be located at least 10 feet from the top of the waterbody bank. Pipe assembly for the waterbody crossing is usually performed in the extra work areas prior to or concurrently with trenching.

Guidance relating to spill prevention at waterbodies is contained in Section IV., "Spill Prevention".

If the facility parallels a waterbody, attempt to maintain at least 10 feet of undisturbed vegetation between the top of bank of the waterbody and the ROW except at the crossing location. Where waterbodies are adjacent to the construction ROW, install sediment barriers along the edge of the construction right-of-way as necessary to contain spoil and sediment within the ROW.

### **3.1.2 Clearing**

Tree and brush clearing will be performed as previously described in Section II, "Upland Construction". Tree clearing within floodplain areas should be limited to those absolutely necessary for construction. All cleared materials will be disposed outside the limits of the floodplain. If no Federal Emergency Management Agency (FEMA) floodplain maps are available for a specific area, assume a 50-foot setback from the waterbody top of bank.

### **3.1.3 Grading**

Construction equipment will not enter the water to grade the banks. Waterbody banks will be graded only where, and as much as necessary to permit safe and efficient operation of construction equipment. Prior to or immediately after grading operations begin sediment filter devices will be installed promptly as close to the water edge as practical. All disturbed areas within 50 feet of the water's edge will be promptly mulched. The mulch will be maintained until the waterbody crossing restoration is complete. Spoil from grading will be piled at least 10 feet from the water's edge and immediately protected with sediment filter devices so as to minimize erosion into the waterbody. On waterbody crossings with approaches sloped 5 percent or greater, waterbars (Figure 17) will be installed to divert surface runoff into adjacent vegetation. If vegetation is sparse or nonexistent, a sediment filter device will be installed at the discharge of the waterbar.

|                             |  |   |
|-----------------------------|--|---|
| Effective Date:<br>7/1/2014 | <b>Environmental Construction<br/>Standard</b> | Standard Number:<br><b>HSE 4440.020</b> |
| Supersedes:<br>11/1/2013    |  | Page 21 of 69                           |

Temporary equipment crossings as illustrated in Figures 19 and 20 will be installed during grading operations at all waterbodies. For proper culvert installation, the Inspector may permit grading/excavating equipment to enter the water. In-stream work, stream crossings, and earth disturbance within 50 feet of a stream requires permit authorization. Equipment bridges may not be required at minor waterbodies that do not have a state designed fishery classification (for example, agricultural or intermittent drainage ditches); however, contact the NGD Survey and Land Group prior to any in-stream work. If an equipment bridge is used it must be constructed in accordance with the approved permits for the site and this ECS.

### 3.1.4 Crossing Techniques

Gas Distribution stream and waterbody crossings require permit authorization from federal, state and/or county authorities. Accordingly, no stream or waterbody crossing shall occur until such permit has been issued or the NGD Survey and Land Group has indicated that a permit is not required.

Crossings shall utilize dry-ditch methodology, including Flumed Stream Crossing (Figure 21) or Stream Crossing with Pump Bypass (Figure 22).

**Upland construction** techniques (Figure 1) may be used for **intermittent waterbody** crossings without perceptible flow at the time of the crossing provided that a culvert is promptly installed to carry potential stormwater flow across the trench area and that erosion and sediment control devices have been installed.

Whenever possible, work should be scheduled for low flow seasons. Any in-channel excavations should be done from the top of banks wherever possible unless this would require the removal of mature trees to access the channel.

**Minor waterbody** crossings, swales, ditches, channels, and waterways should be flumed or pumped past the open trench at the time the crossing is made. All such bypasses should be completed and stabilized prior to diverting flow. If there is an existing base flow or runoff at the time of the trenching, the flume should be installed prior to trench excavation. The flume must be of sufficient size to convey normal stream flow over the open trench. Sandbags should be used to direct flow into the flume. If no base flow or runoff exists, the flume should be installed immediately following backfilling of the trench. In cases where the utility line installation is completed (from initial disturbance to final stabilization) within one day, no flume is required. The disturbed waterway must be re-established and stabilized as part of the final stabilization.

A utility line crossing of a stream channel 10 feet in bottom width or less should be completed within 24 hours (from start to finish) including the trench backfilling, stabilization of stream banks, and stabilization of the areas 50 feet back from the top of each stream bank.

For **intermediate waterbodies** and streams, directional boring is considered

|                             |  |   |
|-----------------------------|--|---|
| Effective Date:<br>7/1/2014 | <b>Environmental Construction<br/>Standard</b> | Standard Number:<br><b>HSE 4440.020</b> |
| Supersedes:<br>11/1/2013    |  | Page 22 of 69                           |

as a preferred alternative for pipeline installation. Directional boring shall be performed as presented in Figure 23, with the layout modified to suit the specific site conditions in a manner that minimizes disturbance. For major streams or waterbodies where one of the above-referenced dry ditch methodologies will be adequate, the crossing, backfilling, and stabilization shall be completed within 48 hours.

**Major waterbodies** or streams should not be constructed without a site specific crossing plan developed in accordance with federal, state and county regulations. In-stream activities shall be completed within 72 hours. A **major waterbody** is classified as a watercourse greater than 100 feet in width.

Facilities for removing sediment from pumped water should be available at the utility line stream crossing site before trenching commences and maintained until trench backfilling is completed. Assembly areas, temporary equipment areas, and nonhazardous material storage areas should be located at least 50 feet back from the top of stream bank. Hazardous or potential polluting material storage areas should be located at least 100 feet back from the top of stream bank. All excess excavated material shall be immediately removed from the stream crossing.

Any pumped water from excavated areas must be filtered prior to discharging into surface waters. The use of Pumped Water Filter Bags (Figure 9), Sediment Traps (Figure 10) or Compost Sock Sediment Traps (Figure 11) are acceptable methods if located on a relatively flat (<5% slope), well-vegetated area. The Sediment Trap or Compost Sock Sediment Trap should be constructed and maintained as presented in the respective figures. The Pumped Water Filter Bag should be designed to trap particles larger than 150 microns. The pump discharge hose shall be inserted into the bags in the manner specified by the manufacturer and securely clamped. When the bag has been filled to ½ its total capacity, it should be replaced with a new bag and properly disposed. Wherever well-vegetated areas are not available, a geotextile underlayment should be used. Consideration should be given to how the bag will be accessed and removed once it has been ½-filled with sediment.

If the dewatering activity results in discharged water entering a wetland or waterbody, the dewatering shall be stopped and the design of the discharge shall be changed to prevent reoccurrence.

### 3.1.5 Trenching

Whenever possible, in-stream work should be scheduled for low flow seasons. Normal flow should be conveyed past the work area by means of a bypass channel, pipe, pump or cofferdam. All such bypasses should be completed and stabilized prior to diverting flow.

Prior to trenching within the waterbody, water impounded in the upland trench will be pumped into a pumped water filter bag or sediment trap draining to a vegetated upland area.

|                             |  |   |
|-----------------------------|--|---|
| Effective Date:<br>7/1/2014 | <b>Environmental Construction<br/>Standard</b> | Standard Number:<br><b>HSE 4440.020</b> |
| Supersedes:<br>11/1/2013    |  | Page 23 of 69                           |

Sediment filter devices for trench spoil will be installed prior to commencing trenching activities. Sediment filter devices can be temporarily removed from the trench line to allow trenching activities to proceed. Any in-channel excavations should be done from the top of banks wherever possible; however, in-stream activities are acceptable as conditions require and with agency approval. Upon completion, all channel banks should be restored and stabilized to pre-construction configurations as much as possible.

All spoil from minor and intermediate waterbody crossings shall be placed in the ROW at least 10 feet from the water's edge or in additional extra work areas. All excavated channel materials that will be subsequently used as backfill should be placed in a temporary stockpile located outside the channel. A sediment barrier or other E&S control device should be installed between the storage pile and the stream channel.

For all new construction activities, the minimum depth of pipeline cover for all waterbody crossings is 36 inches.

Trench breakers (Figure 18) should be installed within the trench on both sides of the stream channel.

### **3.1.6 Blasting**

All drilling and blasting will be done in accordance with the rules and permits issued by the overseeing regulatory agency. Areas requiring blasting to adequately cover the pipeline shall be identified to the extent practicable before construction commences. No blasting shall occur in streams or waterbodies until appropriate regulatory permits have been issued; or until the NGD Survey and Land Group has indicated that none are required. All required precautions will be taken to avoid injury or damage to persons, livestock, environment, or other property.

Upon issuance of a permit, if the waterbody bottom is consolidated rock, it can be drilled and shot at any time prior to commencing the crossing. However, removal of shot rock and any additional drilling, shooting and material removal must be completed within the minimum number of consecutive calendar days practical. The time frame for completing the crossing will immediately commence once a trench of appropriate dimensions is established.

### **3.1.7 Backfilling**

If dewatering the trench is required before backfilling, pump the water into a properly installed pumped water filter bag or a sediment trap (Figures 9 and 10) or a series of compost filter socks or straw wattles (Figures 5 and 8). Dewater the trench in a manner that does not cause erosion and does not result in heavily silt laden water to enter the waterbody.

Waterbody bottoms will be returned as near as practical to their original contours. Spoil from the trench will be used as backfill. Blasted rock shall not

|                             |  |   |
|-----------------------------|--|---|
| Effective Date:<br>7/1/2014 | <b>Environmental Construction<br/>Standard</b> | Standard Number:<br><b>HSE 4440.020</b> |
| Supersedes:<br>11/1/2013    |  | Page 24 of 69                           |

be used for pipeline bedding or padding; rather, suitable material should be used to ensure the safety of the pipeline.

All disturbed areas within the existing channel should be completed and stabilized before flow is redirected into it. Suitable protection should be provided for the stream channel from any disturbed areas that have not yet achieved stabilization.

The sediment filter devices near the water line will be promptly reinstalled after backfilling.

### **3.1.8 Restoration**

Upon completion of the stream crossing, the waterbody, its banks, and 50-foot buffers should be stabilized immediately. In the absence of site-specific seeding recommendations, the specifications listed in Table 1 will be used. If conditions do not permit the preferred method, the construction work area not in use for access will be promptly rough graded and the waterbody banks will be temporarily stabilized with an erosion control blanket (Figure 14) until permanent stabilization can be completed.

For each waterbody crossed install a permanent waterbar (Figure 17) and a trench breaker (Figure 18) at the base of slopes near the waterbody. Locate the trench breaker immediately upslope of the waterbar.

All temporary equipment crossings will be removed once access in the area is no longer required.

Replacement of waterbody banks will be at the approximate original contour. If the waterbody banks are such that an unstable final soil grade would result and vegetative stabilization is inadequate, the Inspector will require mechanical stabilization of the waterbody banks. Mechanical stabilization includes riprap, gabions, or erosion control fabric. These stabilization methods must be pre-approved by federal, state or county agencies prior to installation. Consult with the NGD Survey and Land Group prior to construction.

Sediment filter devices will be removed once permanent revegetation is successful.

## **3.2 WETLAND CROSSINGS**

### **3.2.1 General**

Gas Distribution wetland crossings require permit authorization from federal, state and/or county authorities. Accordingly, no wetland crossing shall occur until such permit has been issued or unless the NGD Survey and Land Group has indicated that a permit is not required. Contact the NGD Survey and Land Group prior to any work within or adjacent to a wetland.

|                             |  |   |
|-----------------------------|--|---|
| Effective Date:<br>7/1/2014 | <b>Environmental Construction<br/>Standard</b> | Standard Number:<br><b>HSE 4440.020</b> |
| Supersedes:<br>11/1/2013    |  | Page 25 of 69                           |

The main objective of any wetland crossing is to construct the pipeline with the least amount of disturbance as possible and restore the original contour of the wetland. Wetlands will be marked in the field by a knowledgeable person prior to the start of construction. The Inspector will maintain these field markings during construction.

Mulch should not be used as a temporary erosion control measure in wetlands unless approved by the state, county or local regulatory agency.

Aboveground facilities will not be located in any wetland except where the location of such facilities outside of wetlands would prohibit compliance with U.S. Department of Transportation (USDOT) regulations.

When water levels are temporarily high, the Inspector will direct that starting construction in the wetland will be postponed until the water levels subside to a suitable level.

Guidance relating to spill prevention at wetlands is contained in Section IV, "Spill Prevention."

### **3.2.2 Crossing Techniques**

Wetland crossings with standing water or saturated soils will be constructed as separate construction entities, as presented in Figure 24. Trenching, pipe installation, backfilling, and restoration will be completed in the minimum number of consecutive calendar days necessary. Clearing, grading and equipment crossing installations are not included as part of the separate construction entity. Pipeline installation by directional bore is the preferred method for wetland areas and shall be performed as presented in Figure 23. The "push-pull" or "float" technique of pipe installation should be utilized whenever water and other site conditions permit.

Crossing wetlands with construction equipment should be avoided wherever possible. Where that is not possible, the location of the crossing and its orientation must be selected so as to have the least possible impact upon the wetland. Temporary crossings should be constructed from materials that can be placed with a minimum disturbance to the soil surface and completely removed when no longer needed. Refer to Figure 25 for the illustration of a stable wetland crossing. Figures 26 and 27 show preferred wetland crossing methods.

Excavated topsoil (with the vegetative root mass) should be carefully removed and stockpiled separately from the subsoil (unless there is standing water or the soil is too saturated to segregate). If standing water or saturated soils are present, operate equipment on equipment mats (Figures 26 and 27). Tree stumps, rock, brush, or soil imported from outside the wetland will not be used to stabilize the construction work area or used as equipment pads in wetlands. Remove all equipment pads during restoration of the wetland.



|                             |  |   |
|-----------------------------|--|---|
| Effective Date:<br>7/1/2014 | <b>Environmental Construction Standard</b> | Standard Number:<br><b>HSE 4440.020</b> |
| Supersedes:<br>11/1/2013    |  | Page 26 of 69                           |

Staging areas will be located at least 50 feet from the wetland edge (unless area is a cultivated agricultural area or previously disturbed site) where topographic conditions permit and will be limited to the minimum necessary to construct the crossing. If topographic conditions do not permit a 50-foot setback, these areas must be located at least 10 feet from the wetland's edge.

The only access roads other than the construction work area that can be used in wetlands are existing roads that require no modification and will have no impact on the wetland. Movement of vehicles across the wetland should utilize a stable wetland crossing as shown in Figure 25.

Limit construction equipment operating in wetland areas to that needed to clear the construction work area, dig the trench, fabricate and install the pipeline, backfill the trench, and restore the ROW. All other construction equipment shall use access roads located in upland areas to the maximum extent practicable. Where access roads in upland areas do not provide reasonable access, limit all other construction equipment to one pass through the wetland using the construction work area. A typical stable wetland crossing is illustrated in Figure 25.

### 3.2.3 Clearing

Tree and brush clearing will be performed as previously described in Section II, "Upland Construction". Tree clearing within wetlands should be limited to those absolutely necessary to complete construction. Cut vegetation off at ground level, leaving existing root systems in place, and remove vegetation from the wetland for disposal. Excavated topsoil with the root mass should be carefully removed and stockpiled separately from the subsoil (unless there is standing water or the soil is too saturated to segregate).

### 3.2.4 Grading

Grading in wetlands will consist of that necessary only for safe and efficient equipment operation. Limit pulling of tree stumps and grading activities to directly over the trenchline. Do not grade or remove stumps or root systems from the rest of the construction work area in wetlands unless the Inspector determines it necessary for safe construction. Areas where stumps are removed will be noted by the Inspector so that those areas can be replanted with woody vegetation as described in wetland restoration.

Where wetlands are adjacent to the construction work area, install sediment barriers along the edge of the construction work area as necessary to prevent sediment flow into the wetland. Remove these sediment barriers after successful construction work area restoration has been completed.

Sediment filter devices will be installed promptly across the construction work area during grading at any wetland edge and maintained until construction work area revegetation is complete. Temporary waterbars will be installed adjacent to wetlands. Guidance for the location of these devices is shown on

|                             |  |   |
|-----------------------------|--|---|
| Effective Date:<br>7/1/2014 | <b>Environmental Construction<br/>Standard</b> | Standard Number:<br><b>HSE 4440.020</b> |
| Supersedes:<br>11/1/2013    |  | Page 27 of 69                           |

Figure 17.

### 3.2.5 Trenching

Sediment filter devices can be temporarily removed from the trench line to allow trenching activities to proceed. Spoil piles will be protected with sediment filter devices to prevent the flow of spoil off the construction work area.

### 3.2.6 Blasting

All drilling and blasting will be done in accordance with the rules and permits issued by the overseeing regulatory agency. Areas requiring blasting to adequately cover the pipeline shall be identified to the extent practicable before construction commences. No blasting shall occur in wetland areas until appropriate regulatory permits have been issued; or until the NGD Survey and Land Group has indicated that none are required. All required precautions will be taken to avoid injury or damage to persons, livestock, environment, or other property.

During the pre-planning of crossing wetlands with standing water or saturated soils, an evaluation will be made concerning the need for blasting. If the evaluation is inconclusive, the wetland will be tested for consolidated rock prior to trenching. If the wetland has consolidated rock, it must be drilled and shot as part of the single permitted construction entity.

Upon issuance of a permit, if the wetland bottom at the desired pipeline depth is consolidated rock, it can be drilled and shot after the removal and segregation of surface material. However; removal of shot rock and any additional drilling, shooting, and material removal must be completed within the minimum number of consecutive calendar days practical. The time frame for completing the crossing will start once the removal of the surface material commences.

### 3.2.7 Backfilling

If trench dewatering is required, the water will be discharged through a pumped water filter bag (Figure 9), into a sediment trap (Figure 10) or into a compost sock sediment trap (Figure 11) that drains to a heavily vegetated area outside the wetland to prevent silt-laden water from entering the wetland. Spoil from the trench will be used as backfill. The surface will be restored as closely as practical to the original contours so that drainage patterns will not be changed. In wetlands without standing water or saturated soils, the conserved topsoil layer will be returned to the surface after backfilling. Sediment filter devices will be promptly installed after backfilling.

Trench breakers should be installed to prevent the trench from draining the wetland or changing its hydrology. For each wetland crossed, install a waterbar and trench breakers at the base of slopes near the boundary between the wetland and adjacent upland areas. Locate the trench breakers



|                             |  |   |
|-----------------------------|--|---|
| Effective Date:<br>7/1/2014 | <b>Environmental Construction<br/>Standard</b> | Standard Number:<br><b>HSE 4440.020</b> |
| Supersedes:<br>11/1/2013    |  | Page 28 of 69                           |

immediately upslope of the waterbars.

### 3.2.8 Restoration

Upon completion of construction in wetland areas with standing water or saturated soils, all access improvements will be promptly removed. In the absence of specific recommendations from conservation authorities, annual ryegrass at the rate of 40 lb. /acre should be applied to areas without standing water. Fertilizer, lime or mulch will not be used unless required as a permit condition. Straw mulch should be used at the rate of three (3) tons per acre and without binding agents.

Where stumps have been removed, woody native vegetation adapted to wetlands will be replanted (if required by the permit conditions), except within five (5) feet of the pipeline centerline or appurtenances.

## 3.3 DIRECTIONAL BORE STREAM OR WETLAND

### 3.3.1 General

Gas Distribution directional bores require permit authorization from federal, state and/or county authorities, complete with water management and inadvertent release of drilling fluid contingency mitigation plans. Accordingly, none shall occur until such permit has been issued.

Directional bore is considered a preferred method for stream and wetland crossings. Successful directional boring can significantly reduce impacts to the stream or wetland since it avoids the need for an open trench through these areas. The directional boring equipment should be set up on an upland site. Silt fence shall be installed between the bore entrance and exit pits and the stream or wetland to prevent any bore mud from draining into the waterbody. See Figure 23 for a typical directional bore layout illustration

### 3.3.2 Inadvertent Release of Drilling Fluid

During the directional bore process an inadvertent release of drilling fluid may occur. An inadvertent release of drilling fluid occurs when the bore fluid seeps to the surface through cracks or voids in the soil. In the event of an inadvertent release of drilling fluid into a wetland or waterbody, the containment and corrective actions described below must be taken immediately to avoid adverse impact to the environment.

1. The source/pumps will be stopped temporarily or the pressure will be decreased;
2. The inadvertent release of drilling fluid will be contained immediately by installing straw bales or compost filter sock (do not construct earthen dikes or berms within wetland or stream areas).
3. The drilling mud will be removed from the site to the greatest extent

|                             |  |   |
|-----------------------------|--|---|
| Effective Date:<br>7/1/2014 | <b>Environmental Construction<br/>Standard</b> | Standard Number:<br><b>HSE 4440.020</b> |
| Supersedes:<br>11/1/2013    |  | Page 29 of 69                           |

possible by manual means such as by use of shovels, wheelbarrows and/or vacuum hoses. If these methods are unsuccessful, contact the NGD Survey and Land Group for your area.

4. The affected areas will be restored as closely as possible to their previous condition.
5. Documentation (including date, time, weather conditions, approximate volume and photographs) must be made and provided to the NGD Survey and Land Group and Environmental Compliance Manager as soon as possible.
6. Any special instructions from the Project Manager or NGD Survey and Land Group must be followed.
7. Once the inadvertent release of drilling fluid has been contained the boring process may continue. Typically, drilling activities will not be suspended unless the inadvertent release creates a threat to public health and safety or unless suspended by the Project Manager or NGD Survey and Land Group.

#### **4. SPILL PREVENTION, CONTAINMENT AND CONTROL**

##### **4.1 GENERAL**

Spills of any amount of petroleum products or polluting materials are to be prevented. The Spill Prevention, Containment and Control (SPCC) Plan will be followed to help avoid spills and minimize the impact of spills which accidentally occur. Applicable Material Safety Data Sheets (MSDS) will be included with the SPCC plan available on site.

- a. Bulk quantities up to 5,000 gallons of diesel fuel and 5,000 gallons of gasoline will be stored in one location (the fuel depot) for the Project. Adequate spill containment measures such as containment dikes with impervious lining will be installed before fuel storage tanks are filled and will be maintained throughout the Project. Bulk quantities of hazardous liquids (e.g., solvents and lubricants) will be stored at the fuel depot locations.
- b. Generally, fuel will be stored at the equipment staging areas and as much equipment as practical will be refueled there. Any equipment that must be refueled in the field will be fueled from tanks carried to the work site. Fuel carriers (greater than 110 gallons capacity) should not cross streams or wetlands unless absolutely necessary. If a stream or wetland crossing is unavoidable, fuel carriers should not cross wetlands or ford waterbodies during periods of high water or saturated soils. Equipment refueling will not be performed within 100 feet of any body of water or wetland except by hand-carried cans (5 gallon maximum capacity) when necessary. If construction equipment must be refueled within 100 feet of a waterbody, follow the procedures outlined in the project-specific SPCC Plan. Care will be taken during refueling not to overfill or spill fuel onto the housing of

|                             |  |   |
|-----------------------------|--|---|
| Effective Date:<br>7/1/2014 | <b>Environmental Construction<br/>Standard</b> | Standard Number:<br><b>HSE 4440.020</b> |
| Supersedes:<br>11/1/2013    |  | Page 30 of 69                           |

equipment.

- c. Lesser quantities of fuel (up to 500 gallons), solvents, and lubricants (e.g., motor oils, hydraulic fluid) may be stored along the construction work area as necessary to service equipment used on the Project (quantities vary depending on the size of the construction spread being used) provided that this storage does not conflict with other parts of this plan. Sorbent booms and clean-up kits will be kept at all storage locations and will be readily available at all times.
- d. All fuel storage areas will be located at least 100 feet from streams, ponds, or wetlands; at least 200 feet from active private water wells, and at least 400 feet from municipal water wells except where using an operational fuel storage area established on company property. All fuel storage areas will not be located within any designated municipal watershed area (except at locations designated for these purposes by an appropriate governmental authority). Equipment servicing, lubricating and refueling will also be in accordance with these requirements whenever possible. Where these conditions cannot be met, the Inspector will prepare a supplemental SPCC plan based on field conditions to protect these resources.
- e. Use of hazardous materials for vehicle maintenance will follow the same requirements mentioned above for equipment refueling. Impervious or sorbent materials will be placed under the work area before the work begins. Additional sorbent materials will also be readily available. Waste materials created during maintenance will be collected for proper disposal. The work site and the vehicle will be checked by a company inspector after the maintenance work is complete to ensure that all hazardous materials are properly contained. All waste material, including partially used or empty containers, discarded parts, clean up rags, and used sorbent materials, as well as discarded hazardous materials containers will be collected for proper disposal.
- f. All motor fuel, lube oil, chemicals, and other polluting substances will be tightly sealed and clearly labeled during transportation and storage.
- g. Fuel trucks, pumps, mechanics' vehicles, the contractor's foremen's' vehicles and company Inspectors' vehicles will be equipped with appropriate sized spill kits containing absorbent materials approved for petroleum products.
- h. Construction equipment will not be washed in any body of water or wetland, nor will runoff resulting from washing operations be permitted to directly enter any body of water or wetland area.
- i. Construction equipment, vehicles, materials, hazardous materials, chemicals, fuels, lubricating oils, and petroleum products will not be parked, stored, or serviced within 100 feet of all bodies of water or wetlands.
- j. All equipment will be checked by a company inspector daily for leaks prior to beginning work in bodies of water or wetlands. Steps will be taken to repair leaks or remove the equipment from service, if necessary.

|                             |  |   |
|-----------------------------|--|---|
| Effective Date:<br>7/1/2014 | <b>Environmental Construction<br/>Standard</b> | Standard Number:<br><b>HSE 4440.020</b> |
| Supersedes:<br>11/1/2013    |  | Page 31 of 69                           |

- k. Disposable protective equipment (2 person) and DOT labels shall be readily available.

If barge mounted equipment is to be employed, the contractor will develop specific spill-prevention plans to be reviewed and approved by the NGD Survey and Land Group.

#### **4.2 SPILL CLEANUP**

Spills occurring during construction or operation and maintenance are to be reported immediately in accordance with company policies.

If a spill should occur, Gas Distribution will ensure immediate action is taken to minimize the impact of the spill and see that appropriate cleanup action is immediately undertaken.

In the event of a spill into or in the vicinity of bodies of water or wetlands, the following will occur immediately:

1. the source will be immediately stopped;
2. the spill will be contained by placing sorbing booms or constructing dikes;
3. the spill will be collected with sorbing materials, skimmed off water surfaces with booms, and/or the contaminated soil will be excavated;
4. the waste materials will be properly stored and disposed of in accordance with company policy.

The affected areas will be restored as closely as possible to their previous condition.

#### **5. ROW MAINTENANCE**

Rights-of-way shall be maintained in a manner that preserves the pre-existing state of the environment, consistent with the integrity of the pipeline and operational needs.

In undeveloped land:

- a. Maintain a minimum right of way width to allow access and repair work on the line.
- b. Where required, inspect growth on the right of way two months after completion of construction to make sure perennial growth has taken place. If this has not occurred, contact the NGD Survey and Land Group for remedial action.
- c. Report erosion problems to the responsible supervisor and NGD Survey and Land Group. Erosion problems are areas where the soil and/or vegetation are carried away by runoff water. Perform corrective action measures when needed. Continued erosion problems may require the assistance of the NGD Survey and Land Group.

|                             |  |   |
|-----------------------------|--|---|
| Effective Date:<br>7/1/2014 | <b>Environmental Construction<br/>Standard</b> | Standard Number:<br><b>HSE 4440.020</b> |
| Supersedes:<br>11/1/2013    |  | Page 32 of 69                           |

In wetland areas and streams:

- a. Maintain rights of way in streams and wetlands according to the governing agency's recommendations and permit requirements.

## 6. ENVIRONMENTAL CONSTRUCTION MANAGEMENT AND INSPECTION

### 6.1 GENERAL

The pertinent Gas Distribution Company is responsible for compliance with the environmental conditions contained in a Project's ECP which include all permits and other approvals and or this ECS; for distribution projects, the company project manager or Inspector shall fill this role.

### 6.2 ENVIRONMENTAL INSPECTION

The Inspector is responsible for assuring that the construction activity is performed in accordance with the environmental conditions of the ECP or this document. At a minimum, the Inspector shall be responsible for:

- a. ensuring compliance with the requirements of the ECP, ECS, and any permits obtained for the Project;
- b. verifying that the limits of authorized construction work areas and locations of access roads are properly marked before clearing;
- c. verifying the location of drainage and irrigation systems;
- d. identifying stabilization needs in all areas;
- e. locating dewatering structures and waterbars to ensure they will not direct water into residential maintained areas, known cultural resource sites, surface waters, or locations of sensitive species;
- f. verifying that trench dewatering activities do not result in the deposition of sand, silt, and/or sediment near the point of discharge into a wetland or waterbody;
- g. testing subsoil and topsoil in agricultural and residential areas to measure compaction and determine the need for corrective action;
- h. advising the Project Manager when conditions (such as wet weather) make it advisable to restrict construction activities in agricultural areas;
- i. ensuring restoration of contours and topsoil;
- j. approving imported soils for use in agricultural and residential areas;
- k. ensuring that temporary erosion controls are properly installed and maintained daily if necessary;
- l. inspecting temporary erosion control measures at least on a daily basis in areas of active construction or equipment operation, on a weekly basis in areas with no construction or equipment operation, and within 24 hours of

|                             |  |   |
|-----------------------------|--|---|
| Effective Date:<br>7/1/2014 | <b>Environmental Construction<br/>Standard</b> | Standard Number:<br><b>HSE 4440.020</b> |
| Supersedes:<br>11/1/2013    |  | Page 33 of 69                           |

each 0.5-inch runoff event. This responsibility may be transferred to field operations after construction is complete but before restoration is successful;

- m. ensuring the repair of all ineffective temporary erosion control measures within 24 hours of identification; and
- n. maintaining written documentation of regular inspections and records of compliance with the environmental conditions of the ECP and other federal or state environmental permits during active construction and restoration.

### **6.3 ENVIRONMENTAL TRAINING**

The Project Coordinator assigned to the construction activity and/or the company employee in charge will be responsible for assuring that the Inspector or other inspectors and any contractor's foreman have been trained in all environmental aspects of the activity and fully understand the environmental conditions contained in the activity's ECP.

### **6.4 CONTRACTOR'S ENVIRONMENTAL COMPLIANCE SPECIALIST (Environmental Foreman)**

For construction activities that utilize an outside contractor, the contractor will be required to provide at least one environmental compliance specialist. This specialist will become thoroughly familiar with the project specific ECP for the activity, or this ECS. The specialist will be responsible for the contractor's efforts to correctly install and maintain environmental control devices and for construction in environmentally sensitive areas. The Contractor's specialist will work in cooperation with the company's employees responsible for environmental compliance.

The Contractor's Environmental Foreman can work/supervise other functions of the pipeline construction, however he/she must be available at all times during the project and have the appropriate number of available employees to adequately implement the project's ECP or this ECS.

### **6.5 ENVIRONMENTAL CONSTRUCTION MANAGEMENT**

The Company Inspector and each functional inspector shall have the authority to stop work on a particular construction function to which they are assigned if it deviates from the environmental conditions of the activity's ECP. The deviation shall be reported immediately to the company employee in charge of the activity and the Inspector. The company employee in charge, the Project Coordinator and the NGD Survey and Land Group will be responsible for the resolution of the deviation.

A representative of the NGD Survey and Land Group may, from time to time, perform inspections of construction activities to review the implementation of the ECP. The NGD Survey and Land Group will have stop-work authority during these inspections should deviations from the activity's ECP occur. Any corrective actions that are required shall be taken as soon as possible.



|                             |  |   |
|-----------------------------|--|---|
| Effective Date:<br>7/1/2014 | <b>Environmental Construction<br/>Standard</b> | Standard Number:<br><b>HSE 4440.020</b> |
| Supersedes:<br>11/1/2013    |  | Page 34 of 69                           |

## 6.6 ENVIRONMENTAL VARIANCES

Unapproved variances from an ECP and this ECS are not permitted. Any proposed variance from an ECP will require approval from the NGD Survey and Land Group prior to commencing the activity. The approval for a variance will be in writing. In instances where written approval is not practical (i.e., emergencies and weekends) verbal approval may be given provided that written confirmation is provided as soon as possible.

Any proposed variance from this ECS will require approval from the NGD Survey and Land Group prior to commencement of the activity.

## 7. EMERGENCY CONSTRUCTION

In the event of an **emergency**, the Company employee in responsible charge will take such action as is necessary to contain the emergency giving due regard to minimizing environmental impact. An emergency is defined as an immediate danger to life, health or the environment. In conjunction with other company policies, the requirements contained in this ECS will be followed as closely as possible. Emergency construction in wetland, streams or waterbodies will require the notification of the permit issuing agency; the NGD Survey and Land Group shall contact these agencies.

Emergency construction may trigger additional environmental and regulatory mandated surveys such as but not limited to, threatened and endangered species surveys, archaeology surveys, or wetland delineations. These surveys will be completed in the fewest number of days from the emergency determination.

## 8. DEFINITION OF TERMS

**AGRICULTURAL LANDS:** Permanent or rotated croplands, hayfields, and pastures.

**BMPs:** Best Management Practices

**CONSTRUCTION WORK AREA:** Construction work areas include permanent and temporary ROW, contractor's yards, pipe and materials storage yards, and access roads.

**ECS:** Environmental Construction Standards

**ECP:** Environmental Compliance Plan

**EMERGENCY:** An immediate danger to life, health or the environment.

**ENVIRONMENTAL INSPECTOR:** The Inspector responsible for environmental compliance on a construction project.

**E&S:** Erosion and Sediment

**EXCEPTIONAL VALUE WATER(S):** Generically, a stream or waterbody which constitutes an outstanding national, State, regional or local resource, such as waters of national, State or county parks or forests, or waters which are used as a source of unfiltered potable water supply, or waters of wildlife refuges or State game lands, and other waters of substantial recreational or ecological significance

|                             |  |   |
|-----------------------------|--|---|
| Effective Date:<br>7/1/2014 | <b>Environmental Construction<br/>Standard</b> | Standard Number:<br><b>HSE 4440.020</b> |
| Supersedes:<br>11/1/2013    |  | Page 35 of 69                           |

**FEMA:** Federal Emergency Management Agency

**FINAL GRADING:** Includes returning the construction work area as closely as practical to its original contour, redistributing conserved topsoil, soil compaction testing in agricultural lands, and installing final interceptor diversions.

**HIGH QUALITY STREAM:** Surface waters having quality which exceeds levels necessary to support propagation of fish, shellfish, and wildlife; and recreation in and on the water.

**IMMEDIATE:** Without interval of time; "right now".

**INADVERTENT RELEASE OF DRILLING FLUID:** Directional bore/drill process when the bore fluid seeps to the surface through cracks or voids in the soil and enters an upland, wetland or waterbody.

**INSPECTOR:** Collectively: the Company Inspector, Chief Inspector, Environmental Inspector, Utility Inspector, or any other inspector assigned to do an environmental task.

**INTERMITTENT WATERBODY:** A waterbody channel which generally carries water in the spring or immediately after a runoff event, and is normally designated on topographic maps and environmental construction drawings with a broken line. Federal and state designations to the determination of "intermittent" vary and include taxa of three (3) or more benthic macroinvertebrates.

**INTERMEDIATE WATERBODY:** A waterbody greater than 10 feet wide (at normal flow depth) at the water's edge at the time of construction but less than or equal to 100 feet wide.

**MAJOR WATERBODY:** A waterbody greater than 100 feet wide (at normal flow depth) at the water's edge at the time of construction.

**MINOR WATERBODY:** A waterbody less than or equal to 10 feet wide (at normal flow depth) at the water's edge at the time of construction.

**MSDS:** Material Safety Data Sheet

**NPDES:** National Pollutant Discharge Elimination System

**NRCS:** Natural Resource Conservation Service

**NOISE SENSITIVE AREA:** Includes residences, schools, churches, cemeteries, hospitals, farms, camping facilities and outdoor amphitheatres and playgrounds.

**NISOURCE NATURAL GAS DISTRIBUTION COMPANIES (Gas Distribution):** This ECS refers specifically to all of NiSource's gas distribution subsidiaries.

**O&M:** Operation and Maintenance activities

**PERENNIAL WATERBODY:** A waterbody which generally flows all year in years of normal rainfall. Waterbody level is generally lowest in the fall and highest in the spring. perennial waterbodies are normally designated with a solid line on topographic maps and environmental construction drawings.

**PROMPTLY:** By the end of the work day.

**RESTORATION:** Includes fertilizing, liming, disking, seeding and mulching, and crimping mulch.



|                             |  |   |
|-----------------------------|--|---|
| Effective Date:<br>7/1/2014 | <b>Environmental Construction<br/>Standard</b> | Standard Number:<br><b>HSE 4440.020</b> |
| Supersedes:<br>11/1/2013    |  | Page 36 of 69                           |

**ROW:** Right-of-way.

**SCARIFY:** To make shallow cuts into the soil surface. This should be accomplished with a disk, rake, tracked equipment (grousers) or other suitable means.

**SEDIMENT FILTER DEVICE:** Properly embedded silt fence or straw bales.

**SPCC:** Spill Prevention Control and Countermeasure Plan

**STEEP SLOPE:** Slope of 30% or greater.

**TEMPORARY STABILIZATION:** Includes installing temporary waterbars and sediment filter devices, mulching critical areas and at times, seeding to hold soil in place until final grading and restoration can be accomplished.

**UPLAND CONSTRUCTION:** All areas which are not waterbodies, streams, or wetlands.

**WATERBODY:** Includes any natural or artificial waterbody or drainage with perceptible flow at the time of crossing, and other permanent waterbodies such as ponds and lakes.

**WETLAND:** An area of special concern with soils prone to holding water for long periods of time, generally also characterized by distinctive plants such as rushes, sedges, cattails, or certain trees. Includes any area that satisfies the requirements of the current Federal methodology for identifying and delineating wetlands.

|                             |  |   |
|-----------------------------|--|---|
| Effective Date:<br>7/1/2014 | <b>Environmental Construction<br/>Standard</b> | Standard Number:<br><b>HSE 4440.020</b> |
| Supersedes:<br>11/1/2013    |  | Page 37 of 69                           |

**TABLE 1**

**SEED MIX REQUIREMENTS FOR UPLAND ROW**

**Recommended Permanent Seed Mixtures Cool and Warm Season Grass**

| <b>Mixture Number</b> | <b>Season</b> | <b>Species</b>           | <b>Seeding Rate</b> |
|-----------------------|---------------|--------------------------|---------------------|
| 1                     | Cool          | Tall fescue*, or         | 79                  |
|                       |               | Fine fescue, plus        | 46                  |
|                       |               | Redtop, or               | 4                   |
|                       |               | Perennial ryegrass, plus | 19                  |
|                       |               | Birdsfoot trefoil        | 8                   |
| 2                     | Cool          | Birdsfoot trefoil, Plus  | 8                   |
|                       |               | Tall fescue*             | 40                  |
| 3                     | Cool          | Orchardgrass, or         | 26                  |
|                       |               | Smooth brome grass, plus | 33                  |
|                       |               | Birdsfoot trefoil        | 8                   |
| 4                     | Warm          | Flatpea, plus            | 27                  |
|                       |               | Tall fescue*, or         | 26                  |
|                       |               | Perennial ryegrass       | 25                  |
| 5                     | Warm          | Deertongue, plus         | 21                  |
|                       |               | Birdsfoot trefoil        | 8                   |
| 6                     | Warm          | Switchgrass, or          | 15                  |
|                       |               | Big Bluestem, plus       | 15                  |
|                       |               | Birdsfoot trefoil        | 8                   |

|                             |  |   |
|-----------------------------|--|---|
| Effective Date:<br>7/1/2014 | <b>Environmental Construction<br/>Standard</b> | Standard Number:<br><b>HSE 4440.020</b> |
| Supersedes:<br>11/1/2013    |  | Page 38 of 69                           |

Table 1 continued.

**Recommended Seed Mixtures for Stabilizing Disturbed Areas**

| Site Condition  | Seed Mixture<br>(Select One Mixture) |
|---|--------------------------------------|
| <b>Cut Slopes and Fills (not mowed)</b><br>Well-drained<br>Variable drainage                                | 2, 4, or 6<br>2                      |
| <b>Cut Slopes and Fills (mowed)</b>   | 1                                    |
| <b>Cut Slopes and Fills (grazed/hay)</b>  | 1, 2, or 3                           |
| <b>Gullies and Eroded Areas</b>   | 2 or 6                               |
| <b>Erosion Control BMPs</b><br>Channels, Drainage ditches, Trap embankments, etc.<br>For hay or silage      | 1 or 2<br>2 or 3                     |
| <b>Right-of-way</b><br>Well-drained<br>Variable drainage<br>Well-drained areas for grazing/hay              | 4 or 6<br>2<br>2 or 3                |
| <b>Strip Mined Areas</b><br>Spoils, waste areas, fly ash, slag, etc. (lime to soil test)<br>For grazing/hay | 2, 4, or 5<br>2, 3, or 6             |

|                             |  |   |
|-----------------------------|--|---|
| Effective Date:<br>7/1/2014 | <b>Environmental Construction<br/>Standard</b> | Standard Number:<br><b>HSE 4440.020</b> |
| Supersedes:<br>11/1/2013    |  | Page 39 of 69                           |

**TABLE 2**  
**SOIL AMENDMENT APPLICATION RATE EQUIVALENTS**

| Soil Amendment                     | Permanent Seeding Application Rate |                   |                   | Notes   |
|------------------------------------|------------------------------------|-------------------|-------------------|---|
|                                    | Per Acre                           | Per 1,000 sq. ft. | Per 1,000 sq. yd. |   |
| <b>Agricultural lime</b>           | 6 tons                             | 240 lb.           | 2,480 lb.         | Or as per soil test; may not be required in agricultural fields |
| <b>10-10-20 fertilizer</b>         | 1,000 lb.                          | 25 lb.            | 210 lb.           | Or as per soil test; may not be required in agricultural fields |
| Temporary Seeding Application Rate |                                    |                   |                   |   |
| <b>Agricultural lime</b>           | 1 ton                              | 40 lb.            | 410 lb.           | Typically not required for soil stockpiles                      |
| <b>10-10-10 fertilizer</b>         | 500 lb.                            | 12.5 lb.          | 100 lb.           | Typically not required for soil stockpiles                      |

**MULCH APPLICATION RATES**

| Mulch Type | Application Rate (Min.) |                   |                   | Notes  |
|------------|-------------------------|-------------------|-------------------|--|
|            | Per Acre                | Per 1,000 sq. ft. | Per 1,000 sq. yd. |  |
| Straw      | 3 tons                  | 140 lb.           | 1,240 lb.         | Either wheat or oat straw, free of weeds, not chopped or finely broken |
| Hay        | 3 tons                  | 140 lb.           | 1,240 lb.         | Timothy, mixed clover and timothy or other native forage grasses       |
| Wood Chips | 4 – 6 tons              | 185 – 275 lb.     | 1,650 – 2,500 lb. | May prevent germination of grasses and legumes                         |
| Hydromulch | 1 ton                   | 47 lb.            | 415               | See limitations above  |

|                             |  |   |
|-----------------------------|--|---|
| Effective Date:<br>7/1/2014 | <b>Environmental Construction Standard</b> | Standard Number:<br><b>HSE 4440.020</b> |
| Supersedes:<br>11/1/2013    |  | Page 40 of 69                           |

**TABLE 3**  
**COMPOST SOCK FABRIC MINIMUM REQUIREMENTS**

| Material Type   | 3 mil HDPE                     | 5 mil HDPE               | 5 mil HDPE               | Multi-Filament Polypropylene (MFPP) | Heavy Duty Multi-Filament Polypropylene (HDMFPP) |
|---|--------------------------------|--------------------------|--------------------------|-------------------------------------|--|
| <b>Material Characteristics</b>                               | Photo-degradable               | Photo-degradable         | Bio-degradable           | Photo-degradable                    | Photo-degradable                                 |
| <b>Sock Diameters</b>   | 12"<br>18"                     | 12"<br>18"<br>24"<br>32" | 12"<br>18"<br>24"<br>32" | 12"<br>18"<br>24"<br>32"            | 12"<br>18"<br>24"<br>32"                         |
| <b>Mesh Opening</b>   | 3/8"                           | 3/8"                     | 3/8"                     | 3/8"                                | 1/8"   |
| <b>Tensile Strength</b>                                       |                                | 26 psi                   | 26 psi                   | 44 psi                              | 202 psi  |
| <b>Ultraviolet Stability % Original Strength (ASTM G-155)</b> | 23% at 1000 hr.                | 23% at 1000 hr.          |                          | 100% at 1000 hr.                    | 100% at 1000 hr.                                 |
| <b>Minimum Functional Longevity</b>                           | 6 months                       | 9 months                 | 6 months                 | 1 year                              | 2 years  |
| <b>Two-ply systems</b>  |                                |                          |                          |                                     |  |
| <b>Inner Containment Netting</b>                              | HDPE biaxial net               |                          |                          |                                     |  |
|   | Continuously wound             |                          |                          |                                     |  |
|   | Fusion-welded junctures        |                          |                          |                                     |  |
|   | 3/4" x 3/4" Max. aperture size |                          |                          |                                     |  |
| <b>Outer Filtration Mesh</b>                                  | Composite Polypropylene Fabric |                          |                          |                                     |  |

|                             |  |   |
|-----------------------------|--|---|
| Effective Date:<br>7/1/2014 | <b>Environmental Construction<br/>Standard</b> | Standard Number:<br><b>HSE 4440.020</b> |
| Supersedes:<br>11/1/2013    |  | Page 41 of 69                           |

|   |   |
|---|---|
|   | (Woven layer and non-woven fleece<br>mechanically fused via needle punch) |
|   | 3/16" Max. aperture size  |
| Sock fabrics composed of burlap may be used on projects lasting 6 months or less. |   |

**COMPOST STANDARDS**

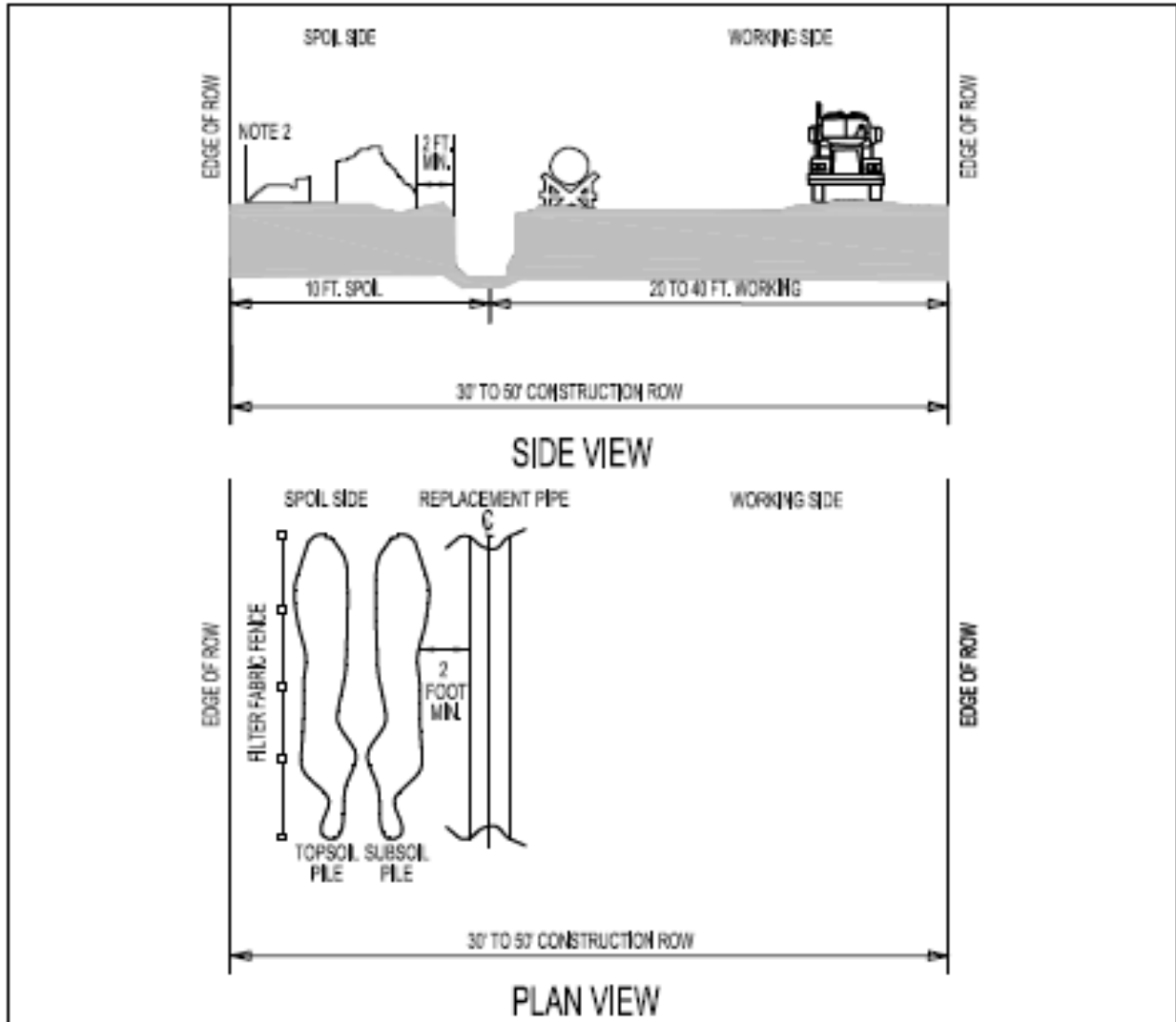
|                            |                                   |
|----------------------------|-----------------------------------|
| Organic Matter Content     | 25% - 100% (dry weight basis)     |
| Organic Portion            | Fibrous and elongated             |
| pH                         | 5.5 – 8.5                         |
| Moisture Content           | 30% - 60%                         |
| Particle Size              | 30% - 50% pass through 3/8" sieve |
| Soluble Salt Concentration | 5.0 dS/m (mmhos/cm) Maximum       |

|

|                             |  |   |
|-----------------------------|--|---|
| Effective Date:<br>7/1/2014 | <b>Environmental Construction<br/>Standard</b> | Standard Number:<br><b>HSE 4440.020</b> |
| Supersedes:<br>11/1/2013    |  | Page 42 of 69                           |


| <b>List of Referenced Figures</b> |  |
|-----------------------------------|--|
| <b>No.</b>                        | <b>Name</b>                                      |
| 1                                 | Typical Upland Construction                      |
| 2                                 | Typical Roadside Construction                    |
| 3                                 | Curb Inlet Protection                            |
| 4                                 | Sediment Barrier Alignment                       |
| 5                                 | Compost Filter Sock                              |
| 6                                 | Filter Fabric Fence                              |
| 7                                 | Straw Bale Barrier                               |
| 8                                 | Straw Wattle                                     |
| 9                                 | Pumped Water Filter Bag                          |
| 10                                | Sediment Trap                                    |
| 11                                | Compost Sock Sediment Trap                       |
| 12                                | Rock Filter                                      |
| 13                                | Rock Construction Entrance                       |
| 14                                | Erosion Control Blanket                          |
| 15                                | Typical Topsoil Conservation                     |
| 16                                | Rock Filter Outlet                               |
| 17                                | Waterbars / Interceptor Diversion                |
| 18                                | Trench Breakers and Barriers                     |
| 19                                | Temporary Equipment Crossing – Equipment Pad     |
| 20                                | Temporary Equipment Crossing – Culvert and Stone |
| 21                                | Typical Flumed Stream Crossing                   |
| 22                                | Typical Stream Crossing with Pump Bypass         |
| 23                                | Directional Bore Stream and Wetland Crossing     |
| 24                                | Typical Wetland Construction                     |
| 25                                | Stable Wetland Crossing                          |
| 26                                | Temporary Wetland Equipment Crossing – Tire Mat  |
| 27                                | Temporary Wetland Equipment Crossing – Wood Mat  |

|                             |  |   |
|-----------------------------|--|---|
| Effective Date:<br>7/1/2014 | <b>Environmental Construction Standard</b> | Standard Number:<br><b>HSE 4440.020</b> |
| Supersedes:<br>11/1/2013    |  | Page 43 of 69                           |



- NOTES:
1. USE FOR DISTRIBUTION PIPELINE.
  2. THE DIMENSIONS SHOWN ON THIS FIGURE ARE TYPICAL.
  3. VARIATIONS FOR STAGING AREAS MAY BE NECESSARY.
  4. FILTER FABRIC FENCE INSTALLED ALONG DOWNGRADIENT ROW SLOPE ONLY IF TRENCH REMAIN OPEN LONGER THAN 24 HOURS.
  5. SPOIL SHALL BE PLACED A MINIMUM OF TWO (2) FEET FROM THE TRENCH PER 29 CFR 1926.850 (j) (2).

NOT TO SCALE

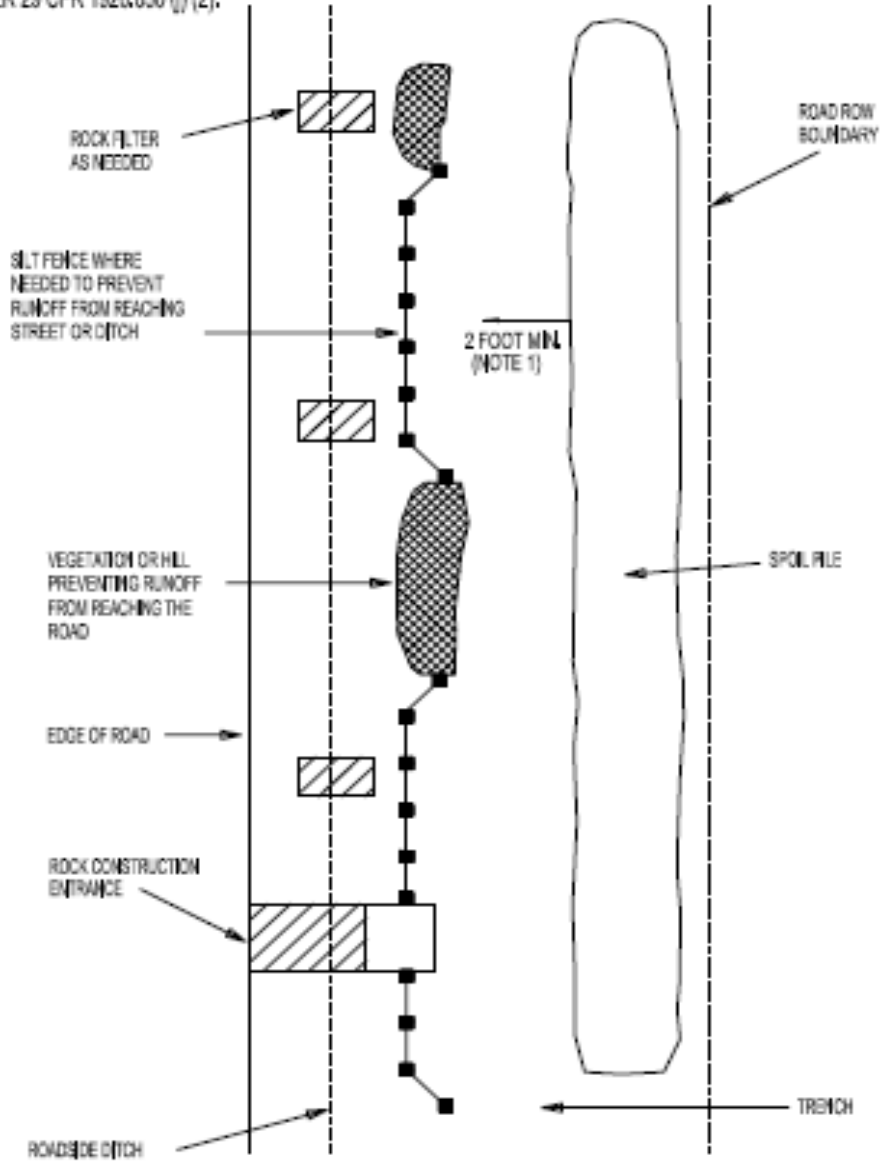
|   |                                |            |
|---|--------------------------------|------------|
| <br>niSource<br>GAS DISTRIBUTION<br>ENVIRONMENTAL CONSTRUCTION STANDARDS | TYPICAL UPLAND<br>CONSTRUCTION | FIGURE - 1 |
|---|--------------------------------|------------|



|                             |  |   |
|-----------------------------|--|---|
| Effective Date:<br>7/1/2014 | <b>Environmental Construction Standard</b> | Standard Number:<br><b>HSE 4440.020</b> |
| Supersedes:<br>11/1/2013    |  | Page 44 of 69                           |

**NOTE:**

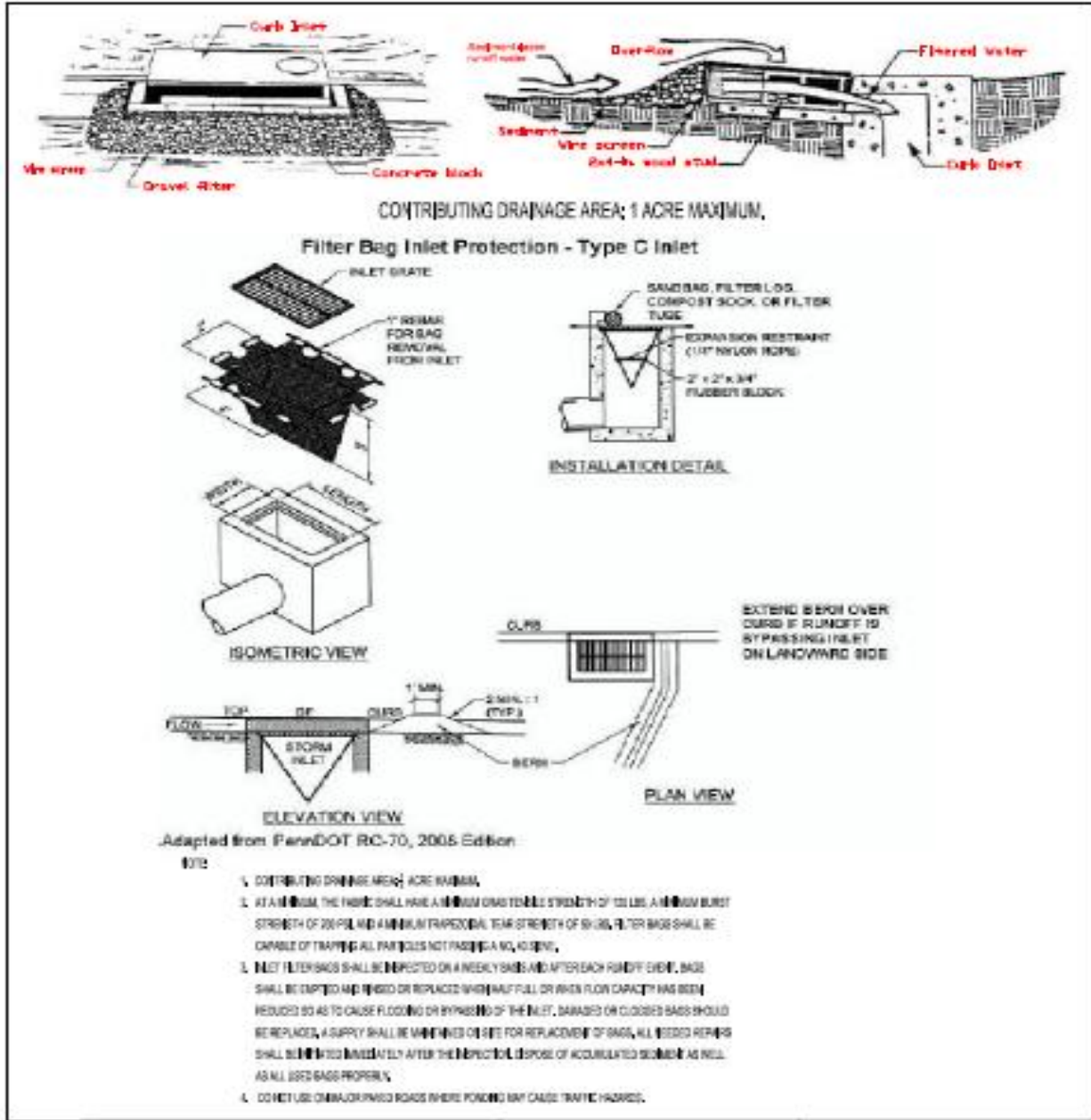
1. SPOIL SHALL BE PLACED A MINIMUM OF TWO (2) FEET FROM THE TRENCH PER 29 CFR 1926.650 (j) (2).



TYPICAL  
ROADSIDE  
CONSTRUCTION

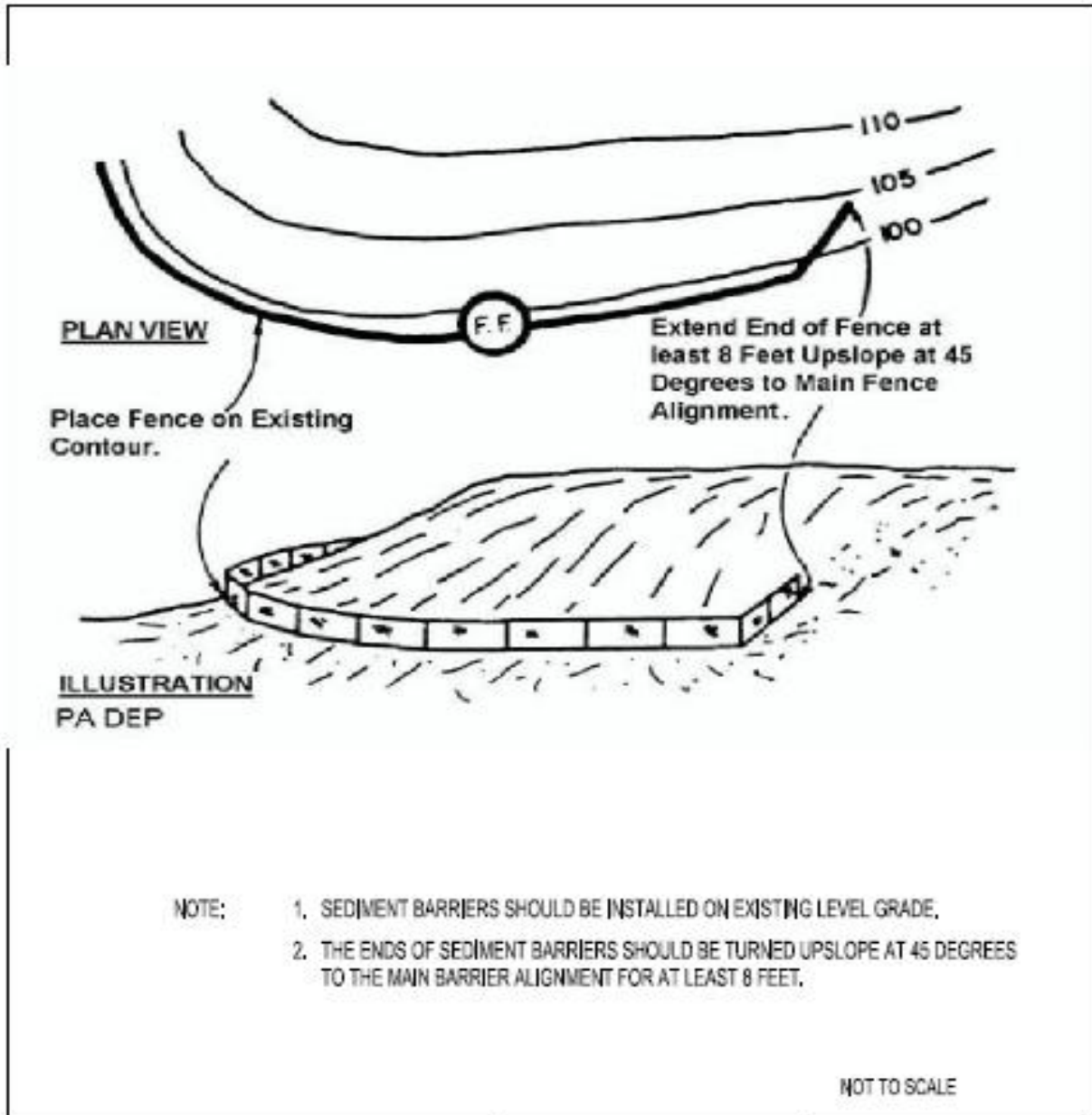
FIGURE -2


|                             |  |   |
|-----------------------------|--|---|
| Effective Date:<br>7/1/2014 | <b>Environmental Construction Standard</b> | Standard Number:<br><b>HSE 4440.020</b> |
| Supersedes:<br>11/1/2013    |  | Page 45 of 69                           |



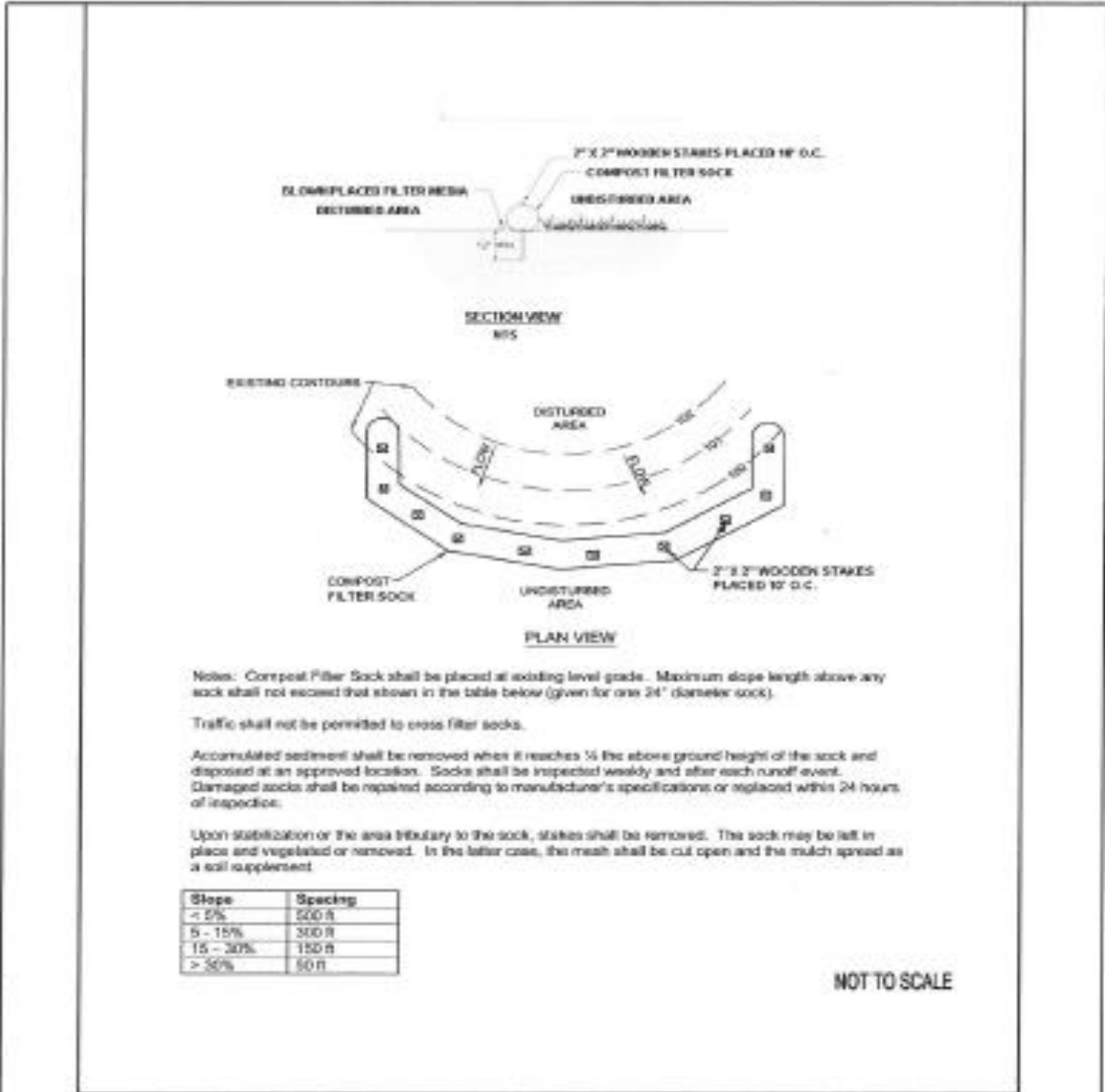
|   |                              |                   |
|---|------------------------------|-------------------|
| <br><b>N</b> SOURCE<br>GAS DISTRIBUTION<br>ENVIRONMENTAL CONSTRUCTION STANDARDS | <b>CURB INLET PROTECTION</b> | <b>FIGURE - 3</b> |
|---|------------------------------|-------------------|

|                             |  |   |
|-----------------------------|--|---|
| Effective Date:<br>7/1/2014 | <b>Environmental Construction Standard</b> | Standard Number:<br><b>HSE 4440.020</b> |
| Supersedes:<br>11/1/2013    |  | Page 46 of 69                           |



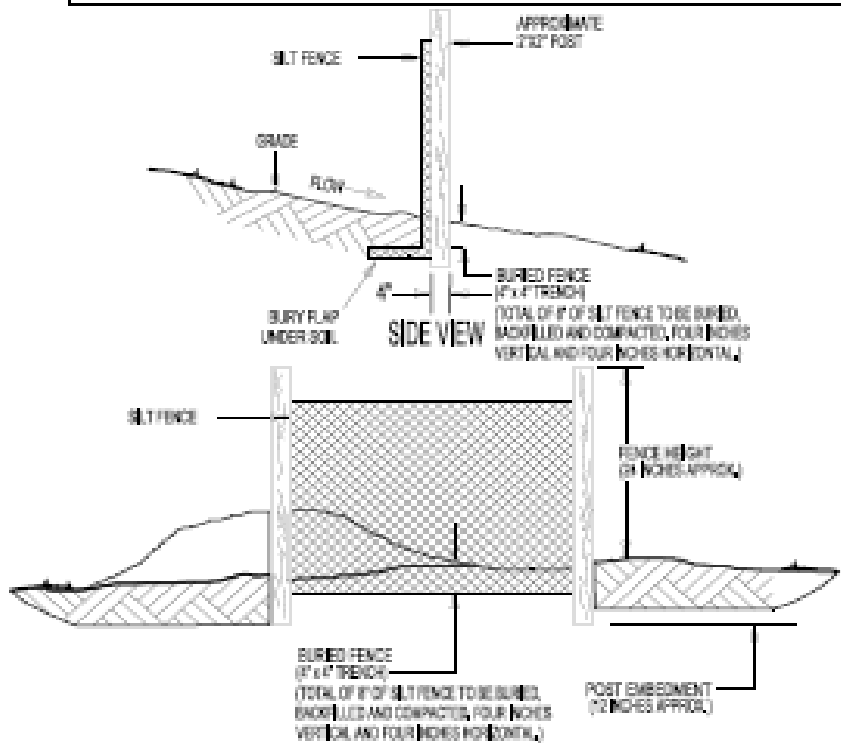
|   |                                  |            |
|---|----------------------------------|------------|
| <br>NISOURCE<br>GAS DISTRIBUTION<br>ENVIRONMENTAL CONSTRUCTION STANDARDS | SEDIMENT<br>BARRIER<br>ALIGNMENT | FIGURE - 4 |
|---|----------------------------------|------------|

|                             |  |   |
|-----------------------------|--|---|
| Effective Date:<br>7/1/2014 | <b>Environmental Construction Standard</b> | Standard Number:<br><b>HSE 4440.020</b> |
| Supersedes:<br>11/1/2013    |  | Page 47 of 69                           |




|                             |  |   |
|-----------------------------|--|---|
| Effective Date:<br>7/1/2014 | <b>Environmental Construction Standard</b> | Standard Number:<br><b>HSE 4440.020</b> |
| Supersedes:<br>11/1/2013    |  | Page 48 of 69                           |

| Slope - Percent | Maximum Slope Length for Silt Fence<br>Maximum Slope Length (ft) Above Fence |                                  |                  |
|-----------------|--|----------------------------------|------------------|
|                 | Standard (10" High) Silt Fence   | Reinforced (30" High) Silt Fence | Super Silt Fence |
| 2 to 1000       | 100  | 500                              | 1000             |
| 5               | 100  | 250                              | 500              |
| 10              | 50   | 100                              | 200              |
| 15              | 35   | 70                               | 140              |
| 20              | 28   | 56                               | 112              |
| 25              | 20   | 40                               | 80               |
| 30              | 15   | 30                               | 60               |
| 35              | 12   | 24                               | 48               |
| 40              | 10   | 20                               | 40               |
| 45              | 8  | 16                               | 32               |
| 50              | 6  | 12                               | 24               |

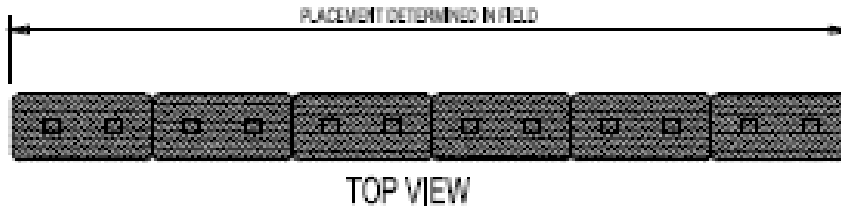
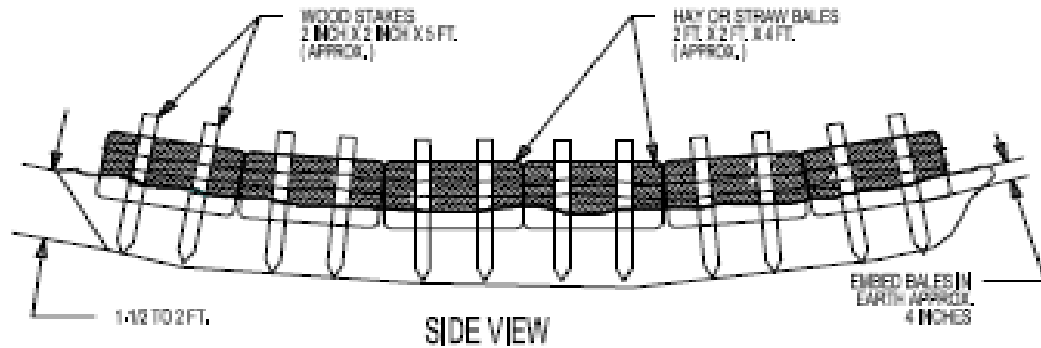


- 1) SILT FENCE SHALL BE PLACED AT LEVEL EXISTING GRADE. BOTH ENDS OF THE FENCE SHALL BE EXTENDED AT LEAST 3 FEET UPSLOPE AT 45 DEGREES TO THE MAIN FENCE ALIGNMENT.
- 2) STAKES WILL BE PLACED A MAXIMUM OF 10 FEET APART IF WIRE SUPPORT IS BEING USED WITH THE FILTER FABRIC, A MAXIMUM OF 5 FEET APART WITHOUT WIRE SUPPORT AND A MAXIMUM OF 3 FEET APART IF THE FENCE IS PLACED ACROSS A DITCH OR SWALE.
- 3) SEDIMENT SHALL BE REMOVED WHEN ACCUMULATIONS REACH HALF THE ABOVEGROUND HEIGHT OF THE FENCE.
- 4) ANY SECTION OF SILT FENCE WHICH HAS BEEN UNDERMINED OR TOPPED SHALL BE IMMEDIATELY REPLACED WITH A ROCK FILTER OUTLET.
- 5) FENCE SHALL BE REMOVED AND PROPERLY DISPOSED OF WHEN AREA IS PERMANENTLY STABILIZED.

NOT TO SCALE

|  |                                    |                   |
|--|------------------------------------|-------------------|
| <br><b>NiSource</b><br>GAS DISTRIBUTION<br>ENVIRONMENTAL CONSTRUCTION STANDARDS | <b>FILTER<br/>FABRIC<br/>FENCE</b> | <b>FIGURE - 6</b> |
|--|------------------------------------|-------------------|

|                             |  |   |
|-----------------------------|--|---|
| Effective Date:<br>7/1/2014 | <b>Environmental Construction Standard</b> | Standard Number:<br><b>HSE 4440.020</b> |
| Supersedes:<br>11/1/2013    |  | Page 49 of 69                           |



| Slope - Percent | Maximum Slope Length (ft) Above Barrier |
|-----------------|---|
| 2 (or less)     | 150                                     |
| 5               | 100                                     |
| 10              | 50                                      |
| 15              | 35                                      |
| 20              | 25                                      |
| 25              | 20                                      |
| 30              | 15                                      |
| 35              | 15                                      |
| 40              | 15                                      |
| 45              | 10                                      |
| 50              | 10                                      |
| > 50            | Not Permitted                           |

**NOTES:**

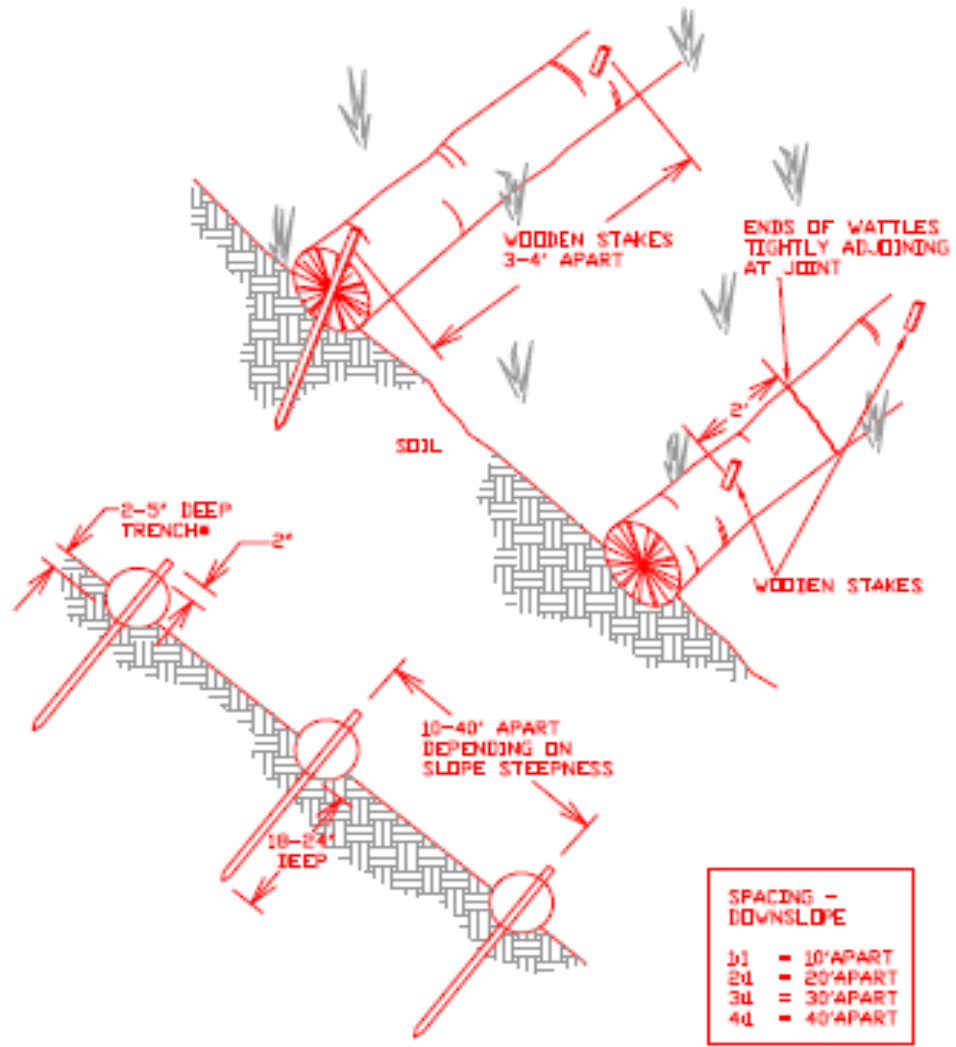
1. STRAW BALE BARRIERS SHALL NOT BE USED FOR PROJECTS EXTENDING MORE THAN 3 MONTHS.
2. STRAW BALE BARRIERS SHALL BE PLACED AT EXISTING LEVEL GRADE WITH ENDS TIGHTLY ABUTTING THE ADJACENT BALES. FIRST STAKE OF EACH BALE SHALL BE ANGLED TOWARD ADJACENT BALE TO DRAW BALES TOGETHER. STAKES SHALL BE DRIVEN FLUSH WITH THE TOP OF THE BALE. BOTH ENDS OF THE BARRIER SHALL BE EXTENDED AT LEAST 8 FEET UP SLOPE AT 45 DEGREES TO THE MAIN BARRIER ALIGNMENT.
3. COMPACTED BACKFILL SHALL EXTEND APPROXIMATELY 4 INCHES ABOVE GROUND LEVEL.
4. SEDIMENT SHALL BE REMOVED WHEN ACCUMULATIONS REACH 1/3 THE ABOVEGROUND HEIGHT OF THE BARRIER. DAMAGED OR DETERIORATED BALES SHALL BE REPLACED IMMEDIATELY UPON INSPECTION.
5. ANY SECTION OF STRAW BALE BARRIER WHICH HAS BEEN UNDERMINED OR TOPPED SHALL BE IMMEDIATELY REPLACED WITHIN 72 HOURS.
6. BALES SHALL BE REMOVED AND PROPERLY DISPOSED OF WHEN AREA IS PERMANENTLY STABILIZED.



**STRAW  
BALE  
BARRIER**


**FIGURE - 7**

|                             |  |   |
|-----------------------------|--|---|
| Effective Date:<br>7/1/2014 | <b>Environmental Construction Standard</b> | Standard Number:<br><b>HSE 4440.020</b> |
| Supersedes:<br>11/1/2013    |  | Page 50 of 69                           |



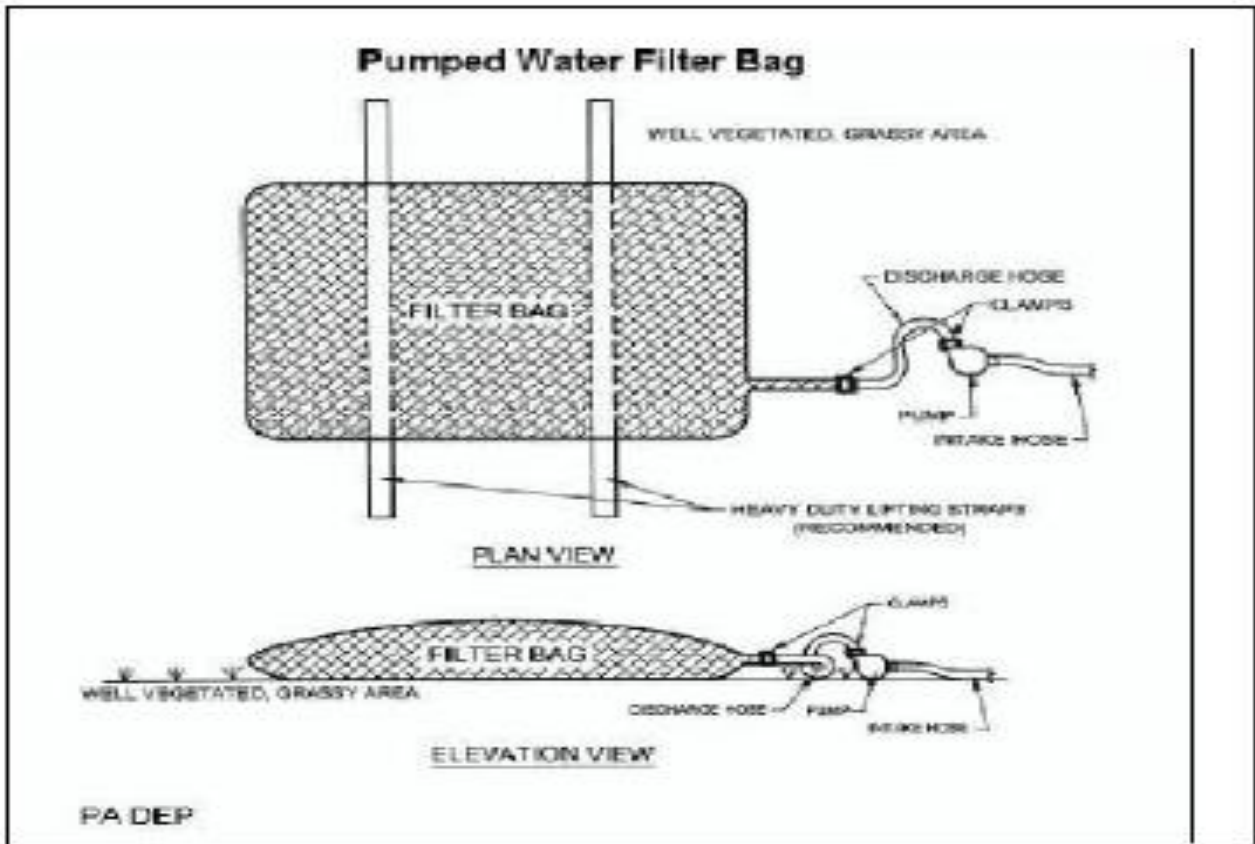
- NOTES:
1. STRAW ROLLS TO BE PLACED IN 2-5" TRENCH DEPENDING ON SLOPE GRADIENT AND SOIL TYPE, RUNOFF MUST NOT BE ALLOWED TO RUN UNDER OR AROUND ROLL. (2-3" TRENCH FOR HARD, ROCKY SOILS & 3-5" TRENCH FOR SOFT, LOAMY SOILS).
  2. STAKES TO BE PLACED APPROX. 3-4' APART, A STAKE SHOULD BE PLACED WITHIN 2' OF EACH END.
  3. STRAW WATTLES MAY BE USED IN PLACE OF SILT FENCE ALONG EASEMENT IN HARD, ROCKY SOILS.

NOT TO SCALE

|  |  |            |
|--|--|------------|
| <br>NSOURCE<br>GAS DISTRIBUTION<br>ENVIRONMENTAL CONSTRUCTION STANDARDS | SEDIMENT FILTER<br>DEVICE<br>STRAW WATTLES | FIGURE - 8 |
|--|--|------------|



|                             |  |   |
|-----------------------------|--|---|
| Effective Date:<br>7/1/2014 | <b>Environmental Construction Standard</b> | Standard Number:<br><b>HSE 4440.020</b> |
| Supersedes:<br>11/1/2013    |  | Page 51 of 69                           |



FILTER BAGS SHALL BE MADE FROM NON-WOVEN GEOTEXTILE MATERIAL SEWN WITH HIGH STRENGTH, DOUBLE STITCHED "J" TYPE SEAMS, THEY SHALL BE CAPABLE OF TRAPPING PARTICLES LARGER THAN 150 MICRONS.


A SUITABLE MEANS OF ACCESSING THE BAG WITH MACHINERY REQUIRED FOR DISPOSAL PURPOSES MUST BE PROVIDED, FILTER BAGS SHALL BE REPLACED WHEN THEY BECOME 1/2 FULL. SPARE BAGS SHALL BE KEPT AVAILABLE FOR REPLACEMENT OF THOSE THAT HAVE FAILED OR ARE FILLED.

BAGS SHALL BE LOCATED IN WELL-VEGETATED (GRASSY) AREA, AND DISCHARGE ONTO STABLE, EROSION RESISTANT AREAS, WHERE THIS IS NOT POSSIBLE, A GEOTEXTILE FLOW PATH SHALL BE PROVIDED, BAGS SHALL NOT BE PLACED ON SLOPES GREATER THAN 5%.

THE PUMP DISCHARGE HOSE SHALL BE INSERTED INTO THE BAGS IN THE MANNER SPECIFIED BY THE MANUFACTURER AND SECURELY CLAMPED.

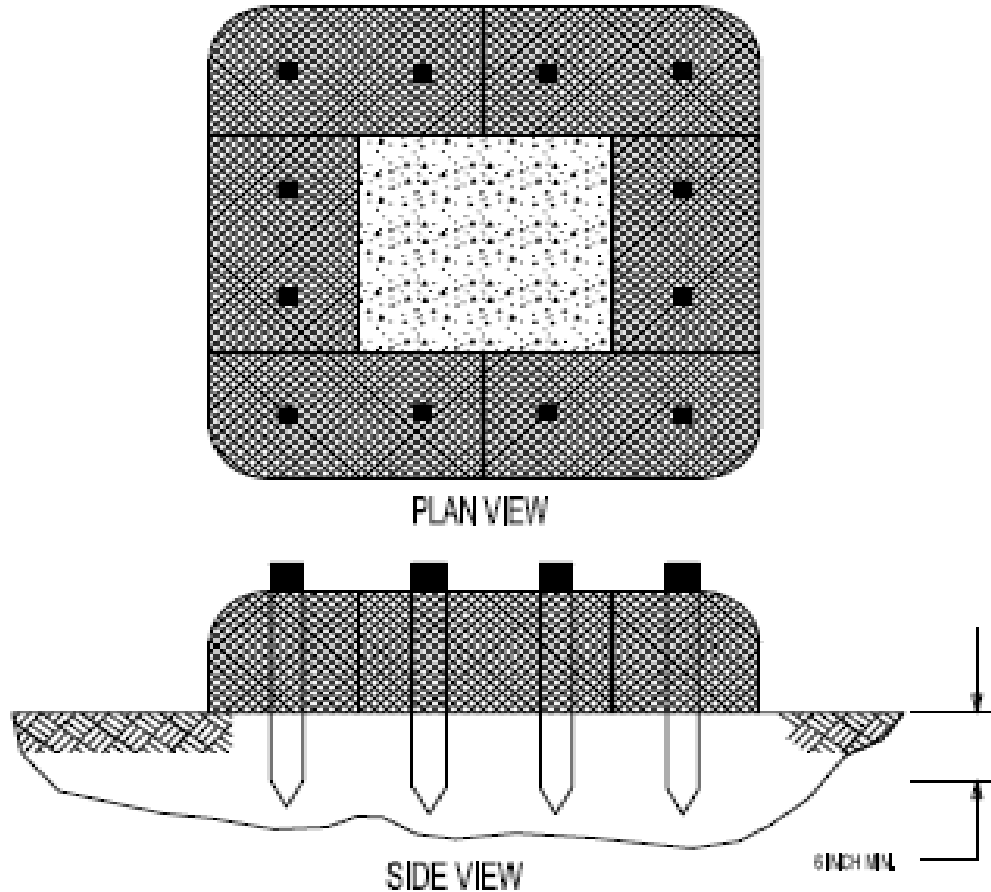
THE PUMPING RATE SHALL BE NO GREATER THAN 750 GPM OR 1/2 THE MAXIMUM SPECIFIED BY THE MANUFACTURER, WHICHEVER IS LESS. PUMP INTAKES SHOULD BE FLOATING AND SCREENED.

FILTER BAGS SHALL BE INSPECTED DAILY, IF ANY PROBLEM IS DETECTED, PUMPING SHALL CEASE IMMEDIATELY AND NOT RESUME UNTIL THE PROBLEM IS CORRECTED.

|   |                            |            |
|---|----------------------------|------------|
| <br>NISOURCE<br>GAS DISTRIBUTION<br>ENVIRONMENTAL CONSTRUCTION STANDARDS | PUMPED WATER<br>FILTER BAG | FIGURE - 9 |
|---|----------------------------|------------|



|                             |  |   |
|-----------------------------|--|---|
| Effective Date:<br>7/1/2014 | <b>Environmental Construction Standard</b> | Standard Number:<br><b>HSE 4440.020</b> |
| Supersedes:<br>11/1/2013    |  | Page 52 of 69                           |

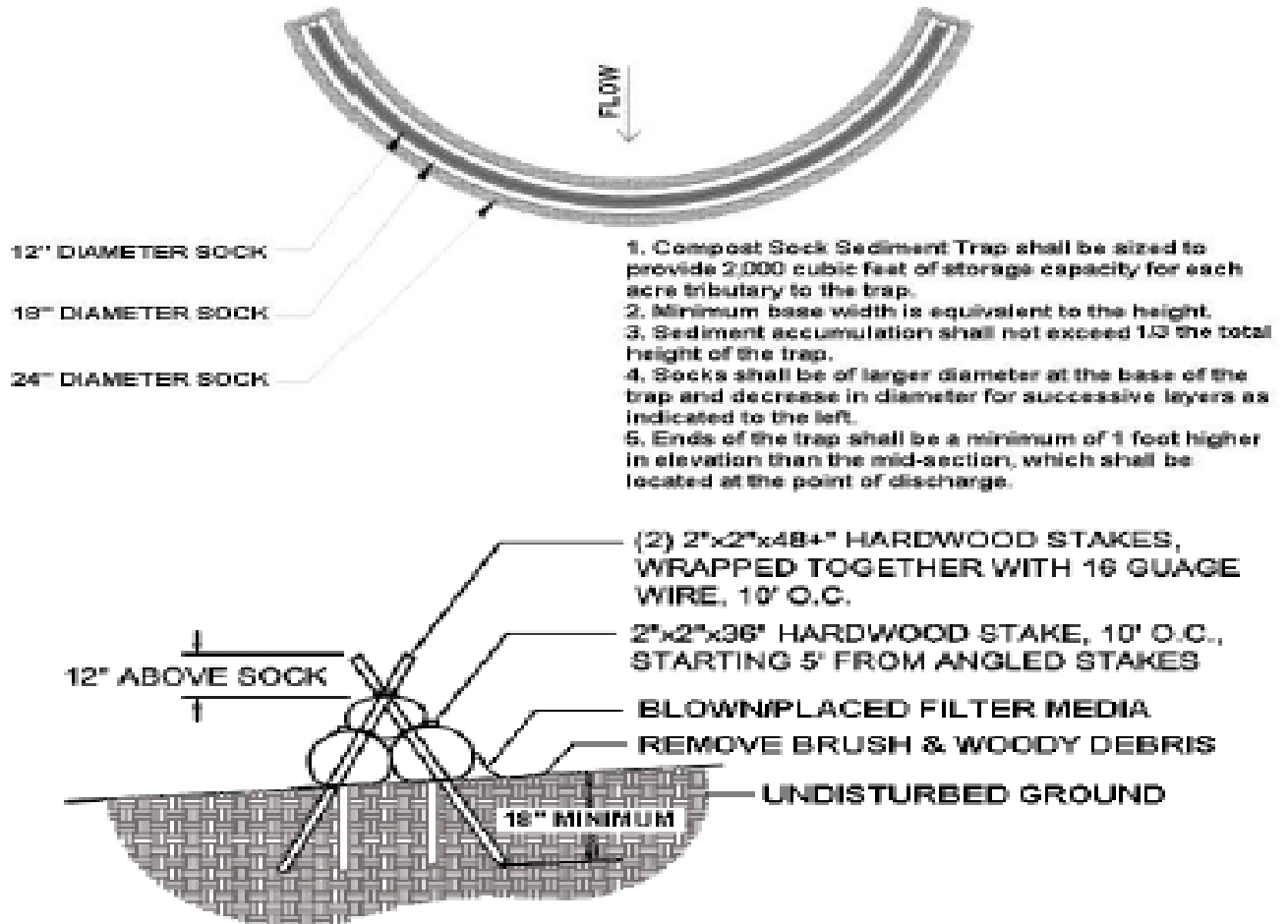


- NOTES:
1. INSTALL BALES AS SHOWN. IF ADDITIONAL STORAGE VOLUME IS NECESSARY, SECURE ADDITIONAL BALES ON TOP OF INITIAL BOTTOM LAYER AND/OR BY INCREASING THE NUMBER BALES IN BOTTOM LAYER.
  2. SECURE EACH BALE & EACH LAYER OF BALES USING EITHER TWO REBARS OR TWO WOODEN STAKES PER BALE.
  3. PLACE A 6 TO 8 INCH DEEP LAYER OF 3/4 TO 1.0 INCH CLEAN STONE ON GROUND COVER INSIDE BALES.
  4. THE SEDIMENT TRAP WILL NOT BE GREATER THAN TWO BALES IN HEIGHT FOR SIX-BALE BOTTOM CONSTRUCTION WITHOUT ADDITIONAL REINFORCEMENT OF TRAP WALLS.

NOT TO SCALE

|                             |  |   |
|-----------------------------|--|---|
| Effective Date:<br>7/1/2014 | <b>Environmental Construction Standard</b> | Standard Number:<br><b>HSE 4440.020</b> |
| Supersedes:<br>11/1/2013    |  | Page 53 of 69                           |


Figure 15: Compost Sock Sediment Trap



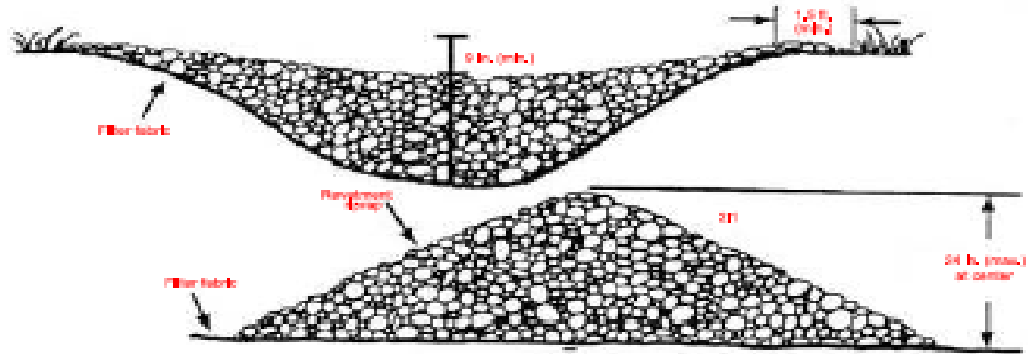
Notes: Compost sock sediment traps shall not exceed three socks in height and shall be stacked in pyramidal form as shown above. Minimum trap height is one 24" diameter sock. Additional storage may be provided by means of an excavated sump 12" deep extending 1 to 3 feet upslope of the socks.

Compost sock sediment traps shall provide 2,000 cubic feet storage capacity with 12" freeboard for each tributary drainage area. The maximum tributary drainage area is 5.0 acres. Since compost socks are "flow-through", no spillway is required.

Compost sock sediment traps shall be inspected weekly and after each runoff event. Sediment shall be removed when it reaches 1/3 the height of the socks.

|   |                                     |             |
|---|-------------------------------------|-------------|
| <br>NiSource<br>GAS DISTRIBUTION<br>ENVIRONMENTAL CONSTRUCTION STANDARDS | COMPOST<br>SOCK<br>SEDIMENT<br>TRAP | FIGURE - 11 |
|---|-------------------------------------|-------------|

|                             |  |   |
|-----------------------------|--|---|
| Effective Date:<br>7/1/2014 | <b>Environmental Construction Standard</b> | Standard Number:<br><b>HSE 4440.020</b> |
| Supersedes:<br>11/1/2013    |  | Page 54 of 69                           |



Contributing drainage area: 2 acres maximum.  
 Dam center: 2 ft, maximum height but at least 9 in, lower than the outer edges at natural ground elevation.  
 Dam side slope: 2:1 or flatter.  
 Distance between dams: Spaced so the toe of the upstream dam is the same as elevation as the top of the downstream dam,

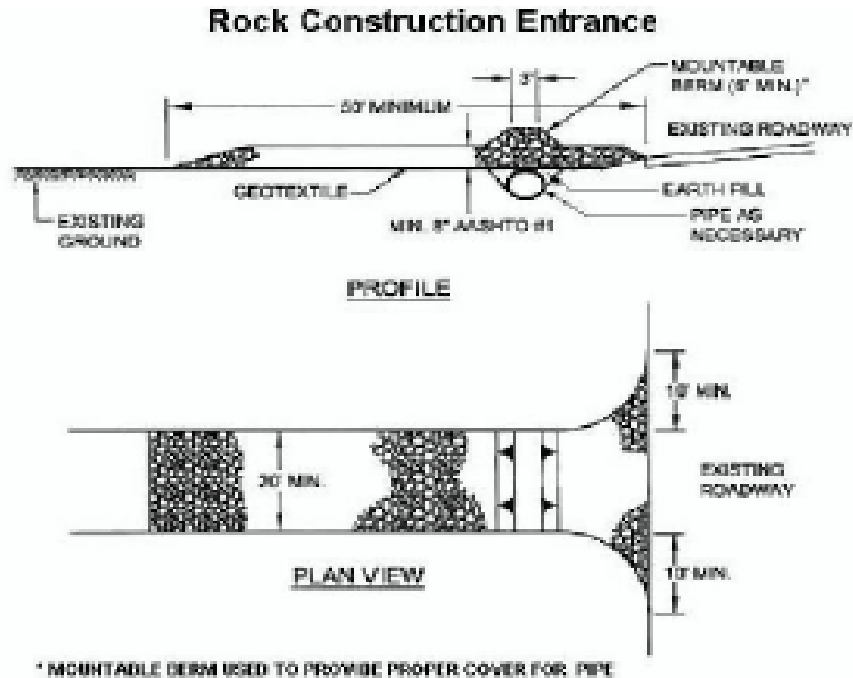


Space rock filter in the channel so the up-stream dam toe elevation (A) and down-stream dam top elevation (B) are the same.

- NOTE:
- ROCK FILTERS SHOULD BE CONSTRUCTED WITH RIPRAP SIZED AS FOLLOWS:
    - FOR CHANNELS WITH TOTAL DEPTH > 3 FEET, USE R-4,
    - FOR CHANNELS WITH TOTAL DEPTH BETWEEN 2 AND 3 FEET, USE R-3.
  - SEDIMENT SHALL BE REMOVED WHEN ACCUMULATIONS REACH HALF THE HEIGHT OF THE FILTER.

NOT TO SCALE

|                             |  |   |
|-----------------------------|--|---|
| Effective Date:<br>7/1/2014 | <b>Environmental Construction Standard</b> | Standard Number:<br><b>HSE 4440.020</b> |
| Supersedes:<br>11/1/2013    |  | Page 55 of 69                           |



Modified from Maryland DOE

- NOTES:
1. REMOVE TOPSOIL PRIOR TO INSTALLATION OF ROCK CONSTRUCTION ENTRANCE, EXTEND ROCK OVER FULL WIDTH OF ENTRANCE,
  2. ROCK CONSTRUCTION ENTRANCE THICKNESS SHALL BE CONSTANTLY MAINTAINED TO THE SPECIFIED DIMENSIONS BY ADDING ROCK, A STOCKPILE SHALL BE MAINTAINED ON SITE FOR THIS PURPOSE,
  3. ALL SEDIMENT DEPOSITED ON PAVED ROADWAYS SHALL BE REMOVED AND RETURNED TO THE CONSTRUCTION SITE IMMEDIATELY, IF EXCESSIVE AMOUNTS OF SEDIMENT ARE BEING DEPOSITED ON THE ROADWAY, EXTEND LENGTH OF ROCK CONSTRUCTION ENTRANCE BY 50 FOOT INCREMENTS UNTIL CONDITION IS ALLEVIATED,
  4. WASHING THE ROADWAY OR SWEEPING THE DEPOSITS INTO ROADWAY DITCHES, SEWERS, CULVERTS, OR OTHER DRAINAGE COURSES IS NOT ACCEPTABLE.

NOT TO SCALE

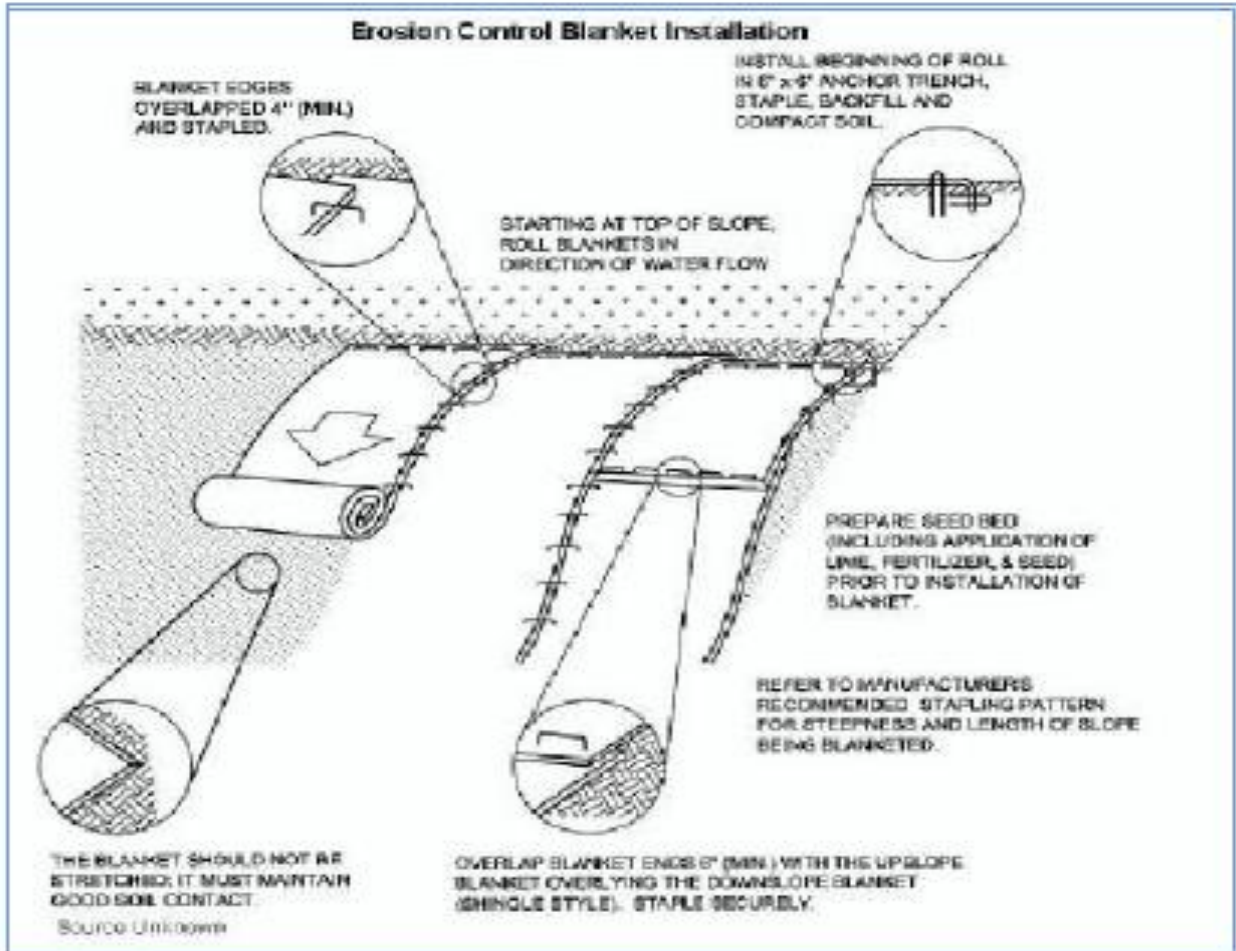


NI SOURCE  
GAS DISTRIBUTION  
ENVIRONMENTAL CONSTRUCTION STANDARDS

ROCK  
CONSTRUCTION  
ENTRANCE


FIGURE - 13

|                             |  |   |
|-----------------------------|--|---|
| Effective Date:<br>7/1/2014 | <b>Environmental Construction Standard</b> | Standard Number:<br><b>HSE 4440.020</b> |
| Supersedes:<br>11/1/2013    |  | Page 56 of 69                           |

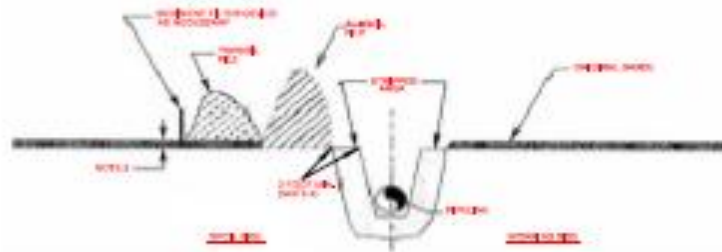


- NOTES:**
1. SEED AND SOIL AMENDMENTS SHALL BE APPLIED ACCORDING TO THE RATES IN THE PLAN DRAWINGS PRIOR TO INSTALLING THE BLANKET.
  2. SLOPE SURFACE SHALL BE FREE OF ROCKS, CLODS, STICKS, AND GRASS.
  3. BLANKET SHALL HAVE GOOD CONTINUOUS CONTACT WITH UNDERLYING SOIL THROUGHOUT THE ENTIRE LENGTH. LAY BLANKET LOOSELY AND STAKE OR STAPLE TO MAINTAIN DIRECT CONTACT WITH SOIL. DO NOT STRETCH BLANKET.

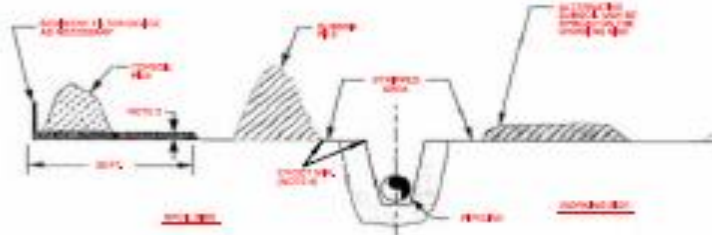
NOT TO SCALE

|   |                               |             |
|---|-------------------------------|-------------|
| <br>NISOURCE<br>GAS DISTRIBUTION<br>ENVIRONMENTAL CONSTRUCTION STANDARDS | EROSION<br>CONTROL<br>BLANKET | FIGURE - 14 |
|---|-------------------------------|-------------|

|                             |  |   |
|-----------------------------|--|---|
| Effective Date:<br>7/1/2014 | <b>Environmental Construction Standard</b> | Standard Number:<br><b>HSE 4440.020</b> |
| Supersedes:<br>11/1/2013    |  | Page 57 of 69                           |



TRENCHLINE AND SPOIL SIDE METHOD



ENTIRE CONSTRUCTION ROW METHOD



REPLACED

- NOTES:
1. OTHER CONFIGURATIONS OF TOPSOIL AND SUBSOIL ARE ACCEPTABLE PROVIDED THEY ARE KEPT SEPARATE.
  2. UP TO 12 INCHES OF TOPSOIL REMOVED.
  3. TOPSOIL AND SUBSOIL PILES WILL BE ADEQUATELY PROTECTED FROM EROSION AND SEDIMENTATION BY USE OF SEDIMENT FILTER DEVICES OR MULCH.
  4. SPOIL SHALL BE PLACED A MINIMUM OF TWO (2) FEET FROM THE TRENCH PER 29 CFR 1926.650 (j) (2).

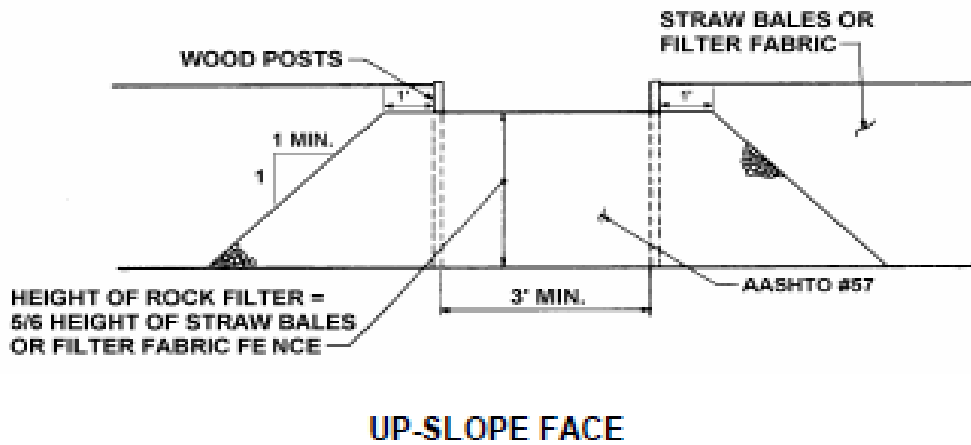
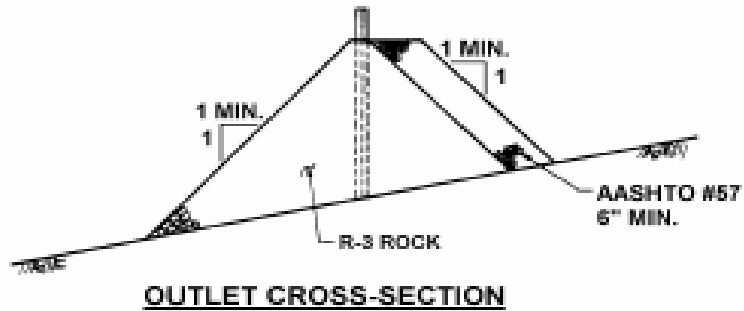
NOT TO SCALE




TYPICAL  
TOPSOIL  
CONSERVATION

FIGURE - 15

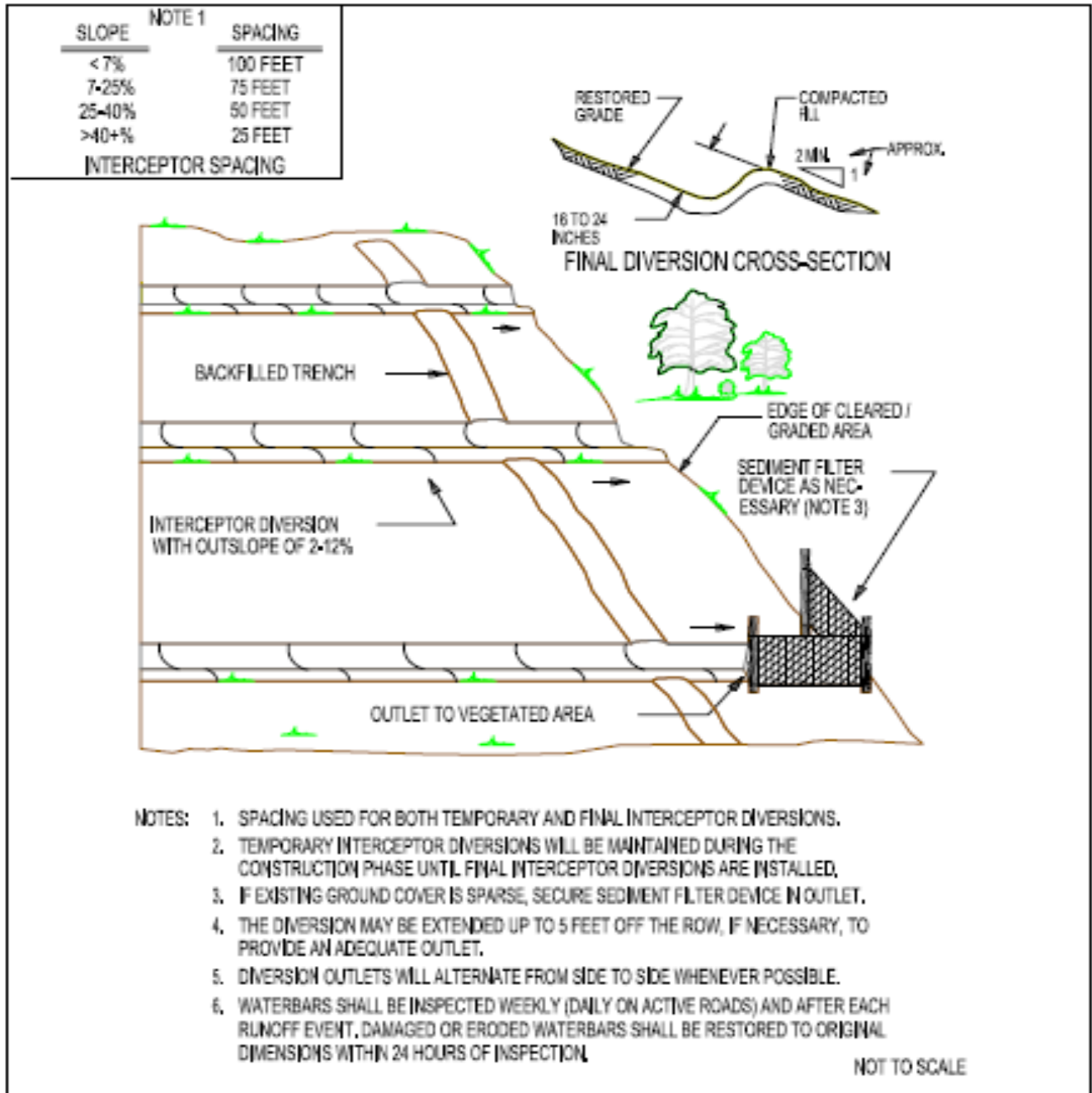
|                             |  |   |
|-----------------------------|--|---|
| Effective Date:<br>7/1/2014 | <b>Environmental Construction Standard</b> | Standard Number:<br><b>HSE 4440.020</b> |
| Supersedes:<br>11/1/2013    |  | Page 58 of 69                           |



SEDIMENT MUST BE REMOVED WHEN ACCUMULATIONS REACH 1/3 THE HEIGHT OF THE OUTLET.

|   |                       |             |
|---|-----------------------|-------------|
| <br>NISOURCE<br>GAS DISTRIBUTION<br>ENVIRONMENTAL CONSTRUCTION STANDARDS | ROCK FILTER<br>OUTLET | FIGURE - 16 |
|---|-----------------------|-------------|

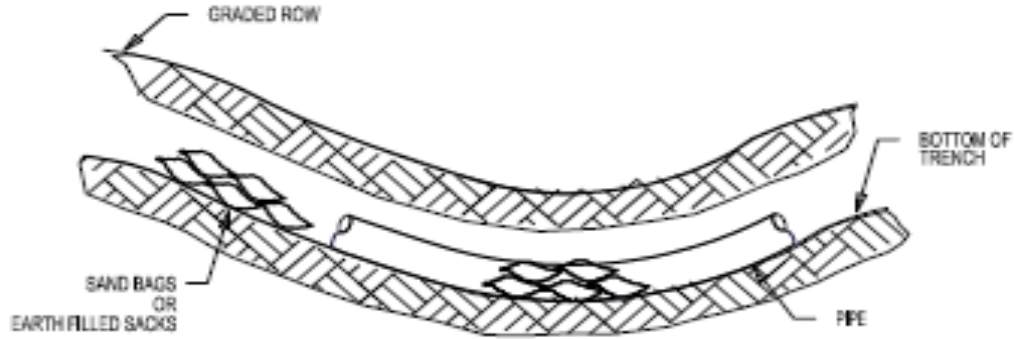
|                             |  |   |
|-----------------------------|--|---|
| Effective Date:<br>7/1/2014 | <b>Environmental Construction Standard</b> | Standard Number:<br><b>HSE 4440.020</b> |
| Supersedes:<br>11/1/2013    |  | Page 59 of 69                           |



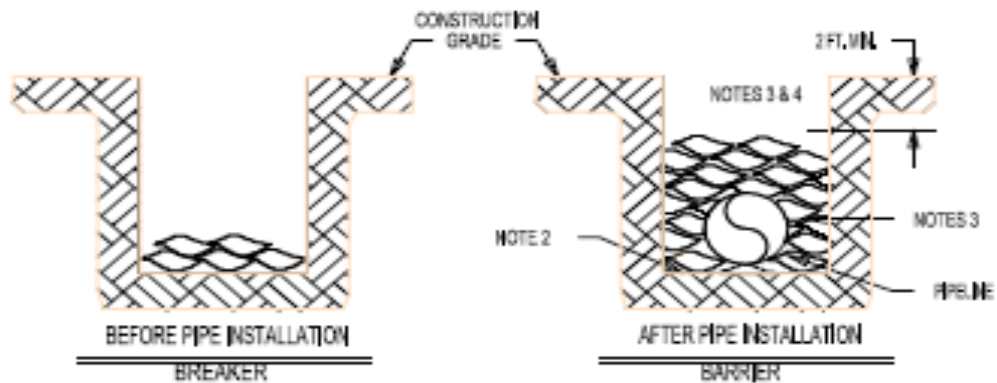
|  |   |                    |
|--|---|--------------------|
| <br>NiSource<br>GAS DISTRIBUTION<br>ENVIRONMENTAL CONSTRUCTION STANDARDS | <b>WATERBARS/<br/>INTERCEPTOR<br/>DIVERSION</b> | <b>FIGURE - 17</b> |
|--|---|--------------------|



|                             |  |   |
|-----------------------------|--|---|
| Effective Date:<br>7/1/2014 | <b>Environmental Construction Standard</b> | Standard Number:<br><b>HSE 4440.020</b> |
| Supersedes:<br>11/1/2013    |  | Page 60 of 69                           |



SIDE VIEW

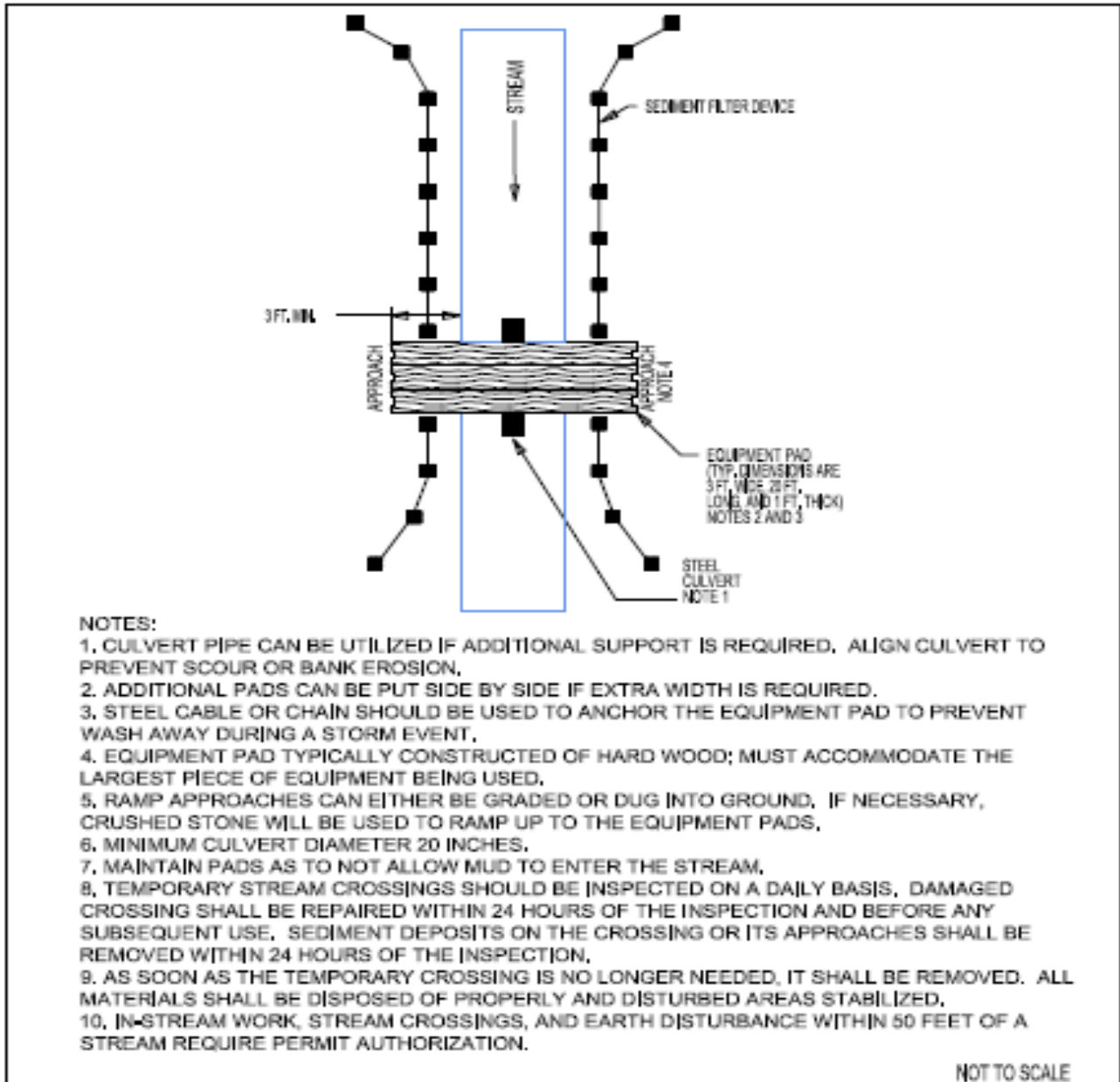



FRONT VIEW

- NOTES:
1. INSTALL AT EVERY SECOND INTERCEPTOR DIVERSION PROMPTLY AS TRENCH IS COMPLETED,
  2. PRIOR TO LOWERING IN, REMOVE ALL DECOMPOSED MATERIAL AND ROCKS,
  3. INSTALL SACKS TO TOP OF TRENCH ON STEEP GRADES THAT ARE NOT USED FOR FARMING,
  4. TOP OF TRENCHLINE BARRIER WILL BE BELOW PLOW DEPTH IN AGRICULTURAL LAND,
  5. DOUBLE STAKED HAY / STRAW BALES MAY BE SUBSTITUTED FOR SAND BAGS ( EARTH FILLED SACKS ) AS TEMPORARY BREAKERS WHERE APPROPRIATE.

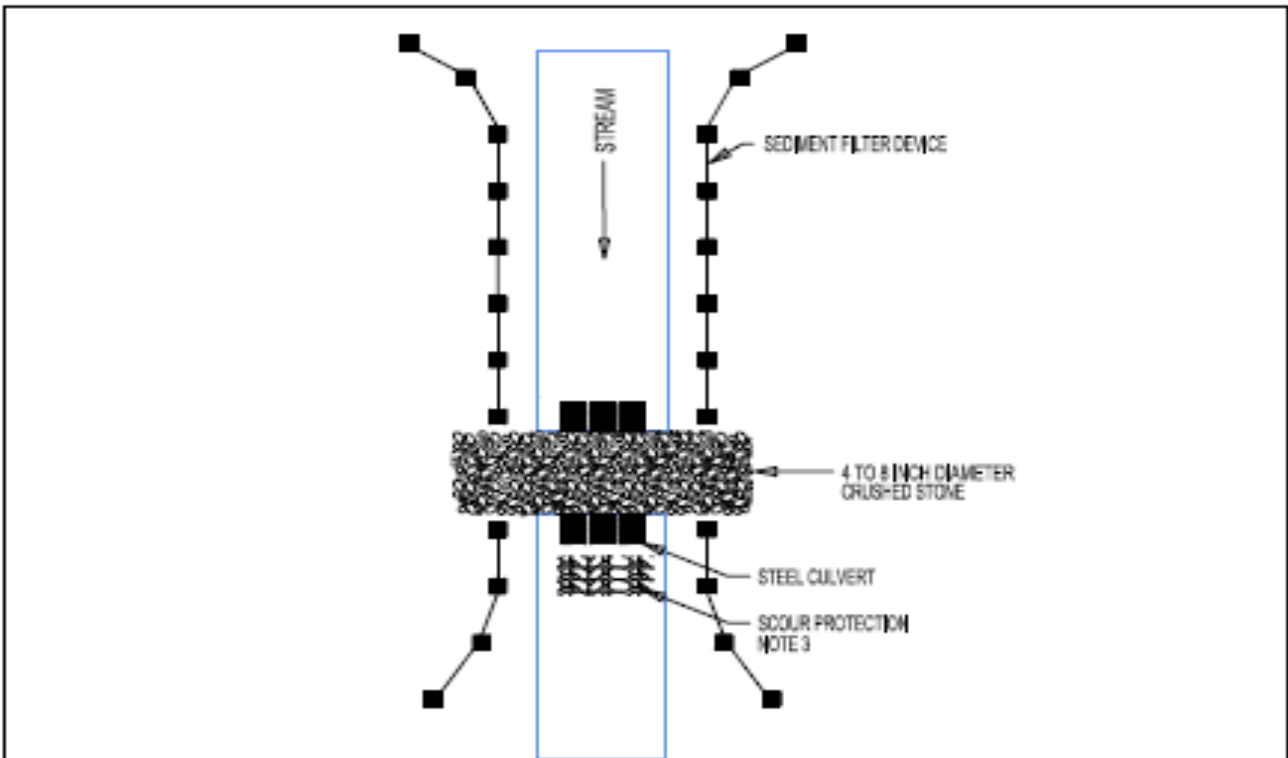
NOT TO SCALE

|                             |  |   |
|-----------------------------|--|---|
| Effective Date:<br>7/1/2014 | <b>Environmental Construction Standard</b> | Standard Number:<br><b>HSE 4440.020</b> |
| Supersedes:<br>11/1/2013    |  | Page 61 of 69                           |




|   |   |             |
|---|---|-------------|
| <br>NISOURCE<br>GAS DISTRIBUTION<br>ENVIRONMENTAL CONSTRUCTION STANDARDS | TEMPORARY<br>EQUIPMENT CROSSING<br>EQUIPMENT PADS | FIGURE - 19 |
|---|---|-------------|

|                             |  |   |
|-----------------------------|--|---|
| Effective Date:<br>7/1/2014 | <b>Environmental Construction Standard</b> | Standard Number:<br><b>HSE 4440.020</b> |
| Supersedes:<br>11/1/2013    |  | Page 62 of 69                           |

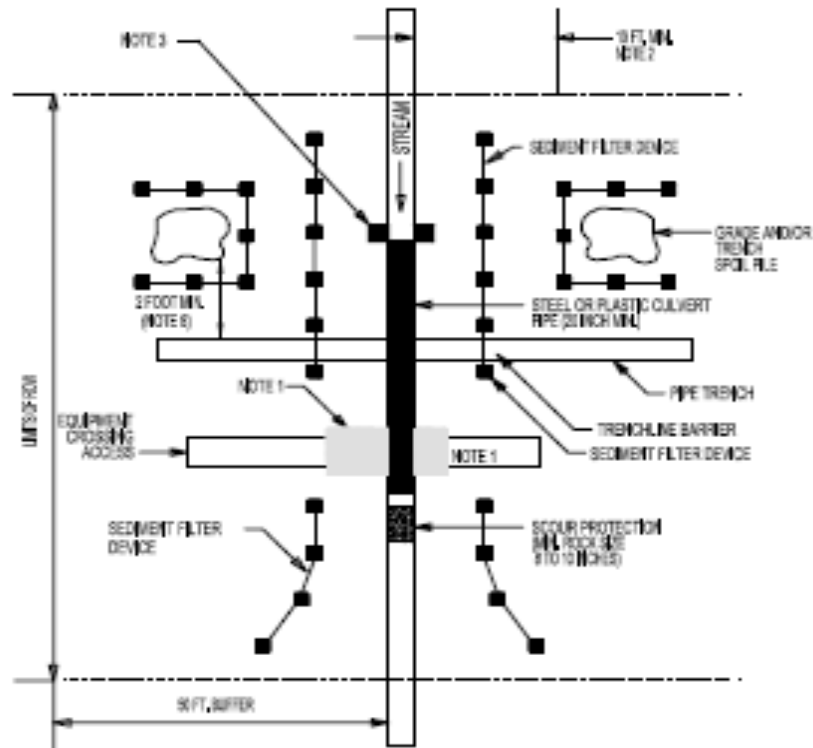


- NOTES:
1. MINIMUM CONTOURING OF THE BOTTOM NECESSARY TO LAY THE CULVERTS LEVEL MAY BE DONE.
  2. USE AS MANY CULVERTS AS REQUIRED TO SPAN ENTIRE STREAM BED.  
( CULVERTS SHALL BE PLACED SIDE BY SIDE. )
  3. STONES WILL BE PLACED AT THE OUTLET OF ALL CULVERTS TO PROVIDE SCOUR PROTECTION IN THE EXISTING CHANNELS. MINIMUM ROCK SIZE: 8 TO 10 INCHES.
  4. MINIMUM CULVERT DIAMETER 20 INCHES.
  5. MAINTAIN ROCK AS NOT TO ALLOW MUD TO ENTER THE STREAM.
  6. ALIGN CULVERTS TO PREVENT BANK EROSION.
  7. TEMPORARY STREAM CROSSINGS SHOULD BE INSPECTED ON A DAILY BASIS, DAMAGED CROSSINGS SHALL BE REPAIRED WITHIN 24 HOURS OF THE INSPECTION AND BEFORE ANY SUBSEQUENT USE. SEDIMENT DEPOSITS ON THE CROSSING OR ITS APPROACHES SHALL BE REMOVED WITHIN 24 HOURS OF THE INSPECTION.
  8. AS SOON AS THE TEMPORARY CROSSING IS NO LONGER NEEDED, IT SHALL BE REMOVED. ALL MATERIALS SHALL BE DISPOSED OF PROPERLY AND DISTURBED AREAS STABILIZED.
  9. IN-STREAM WORK, STREAM CROSSINGS, AND EARTH DISTURBANCE WITHIN 50 FEET OF A STREAM REQUIRE PERMIT AUTHORIZATION.

NOT TO SCALE


|   |  |             |
|---|--|-------------|
| <br>NISOURCE<br>GAS DISTRIBUTION<br>ENVIRONMENTAL CONSTRUCTION STANDARDS | TEMPORARY<br>EQUIPMENT CROSSING<br>CULVERT AND STONE | FIGURE - 20 |
|---|--|-------------|

|                             |  |   |
|-----------------------------|--|---|
| Effective Date:<br>7/1/2014 | <b>Environmental Construction Standard</b> | Standard Number:<br><b>HSE 4440.020</b> |
| Supersedes:<br>11/1/2013    |  | Page 63 of 69                           |

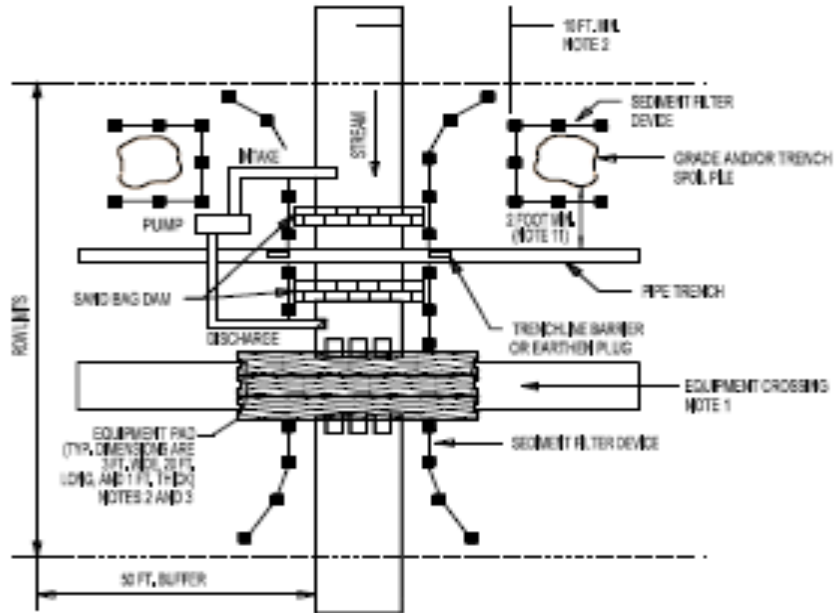


- NOTES:
1. EQUIPMENT CROSSINGS ARE TO BE PREPARED AS ILLUSTRATED IN FIGURE 18 OR 19.
  2. GRADE AND TRENCH SPOIL WILL BE STOCKPILED AT LEAST 10 FEET FROM THE WATER'S EDGE, TOPOGRAPHY PERMITTING.
  3. SAND BAGS OR EARTH FILLED SACKS WILL BE PLACED AT UPSTREAM END OF CULVERT TO CHANNEL FLOW.
  4. PIPE CULVERT FOR ACCESS ROAD AND FLUME PIPE MAY BE ONE CONTINUOUS PIPE.
  5. TRENCH PLUGS SHALL BE INSTALLED WITHIN THE TRENCH ON BOTH SIDES OF THE STREAM CHANNEL.
  6. WATER ACCUMULATING IN THE WORK AREA SHALL BE PUMPED TO A PUMPED WATER FILTER BAG OR SEDIMENT TRAP PRIOR TO DISCHARGING INTO ANY SURFACE WATER.
  7. IN-STREAM WORK, STREAM CROSSINGS, AND EARTH DISTURBANCE WITHIN 50 FEET OF A STREAM REQUIRE PERMIT AUTHORIZATION.
  8. SPOIL SHALL BE PLACED A MINIMUM OF TWO (2) FEET FROM THE TRENCH PER 29 CFR 1926.650 (j) (2).

NOT TO SCALE

|   |   |                    |
|---|---|--------------------|
| <br>NISOURCE<br>GAS DISTRIBUTION<br>ENVIRONMENTAL CONSTRUCTION STANDARDS | <b>TYPICAL FLUMED<br/>STREAM CROSSING</b> | <b>FIGURE • 21</b> |
|---|---|--------------------|

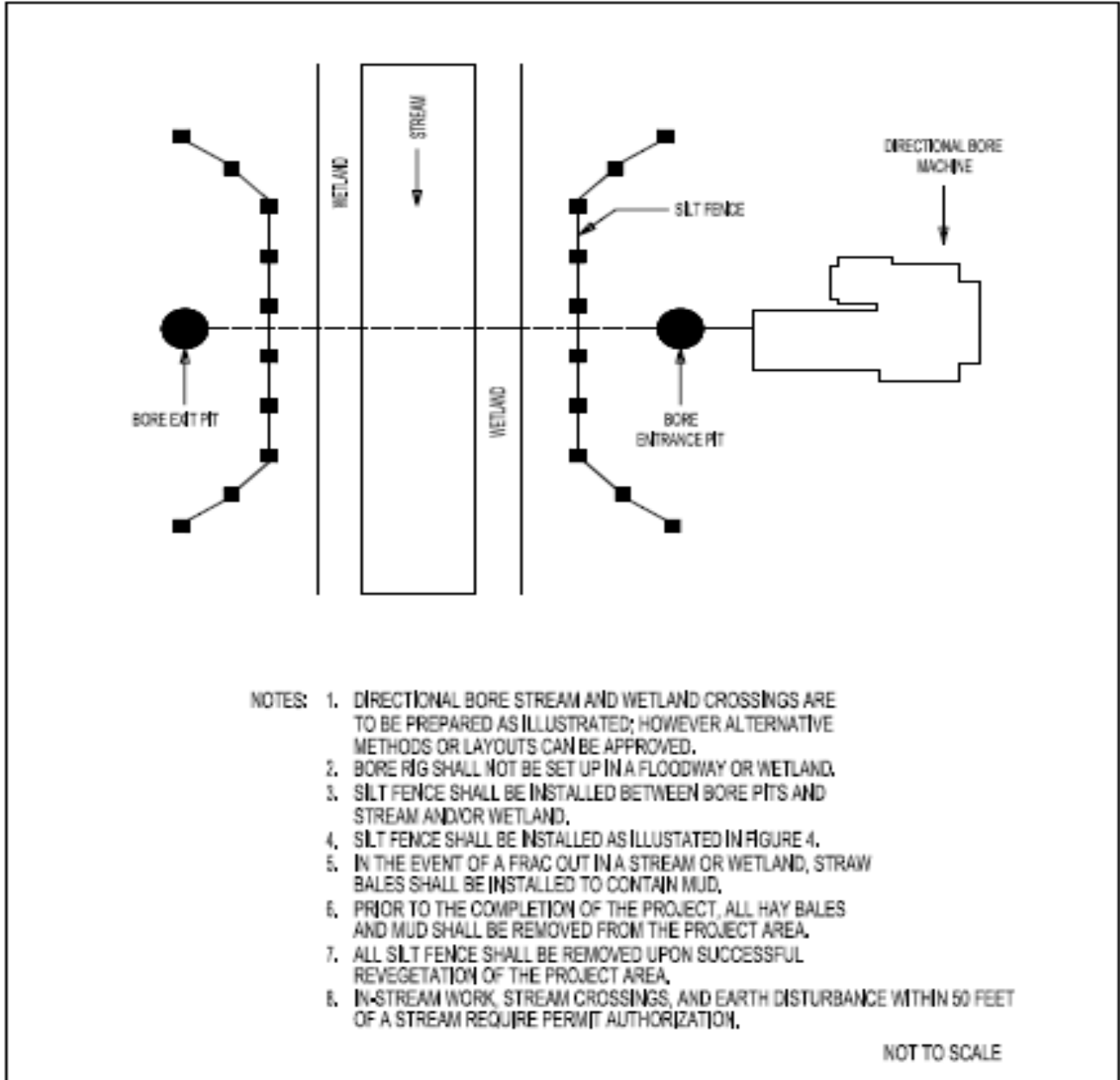
|                             |  |   |
|-----------------------------|--|---|
| Effective Date:<br>7/1/2014 | <b>Environmental Construction Standard</b> | Standard Number:<br><b>HSE 4440.020</b> |
| Supersedes:<br>11/1/2013    |  | Page 64 of 69                           |




- NOTES:
1. EQUIPMENT CROSSINGS ARE TO BE INSTALLED PERPENDICULAR TO STREAM, AS ILLUSTRATED.
  2. GRADE AND TRENCH SPOIL WILL BE STOCKPILED AT LEAST 10 FEET FROM THE WATERS' EDGE, TOPOGRAPHY PERMITTING.
  3. PUMP INTAKES WILL BE SCREENED. PREVENT STREAMBED SCOUR AT DISCHARGE.
  4. SUFFICIENT PUMP CAPACITY WILL BE USED TO MAINTAIN STREAM FLOW AT ALL TIMES UNTIL BACKFILL AND REMOVAL OF SANDBAG DAM.
  5. BACKUP PUMPS ( AS SAME NUMBER AND CAPACITY AS ACTIVE PUMPS ) WILL BE READILY AVAILABLE IN WORKING CONDITION ON SITE AT CROSSING.
  6. CONSTRUCT DAMS WITH MATERIAL THAT PREVENT SEDIMENT AND OTHER POLLUTANTS FROM ENTERING THE WATERBODY.
  7. MONITOR THE DAM AND PUMPS TO ENSURE PROPER OPERATIONS THROUGHOUT THE WATERBODY CROSSING.
  8. TRENCH PLUGS SHALL BE INSTALLED WITHIN THE TRENCH ON BOTH SIDES OF THE THE STREAM CHANNEL.
  9. WATER ACCUMULATING IN THE WORK AREA SHALL BE PUMPED TO A PUMPED WATER FILTER BAG OR SEDIMENT TRAP PRIOR TO DISCHARGING INTO ANY SURFACE WATER.
  10. IN-STREAM WORK, STREAM CROSSINGS, AND EARTH DISTURBANCE WITHIN 50 FEET OF A STREAM REQUIRE PERMIT AUTHORIZATION.
  11. SPOIL SHALL BE PLACED A MINIMUM OF TWO (2) FEET FROM THE TRENCH PER 29 CFR 1926.650 (j) (2).

NOT TO SCALE

|                             |  |   |
|-----------------------------|--|---|
| Effective Date:<br>7/1/2014 | <b>Environmental Construction Standard</b> | Standard Number:<br><b>HSE 4440.020</b> |
| Supersedes:<br>11/1/2013    |  | Page 65 of 69                           |

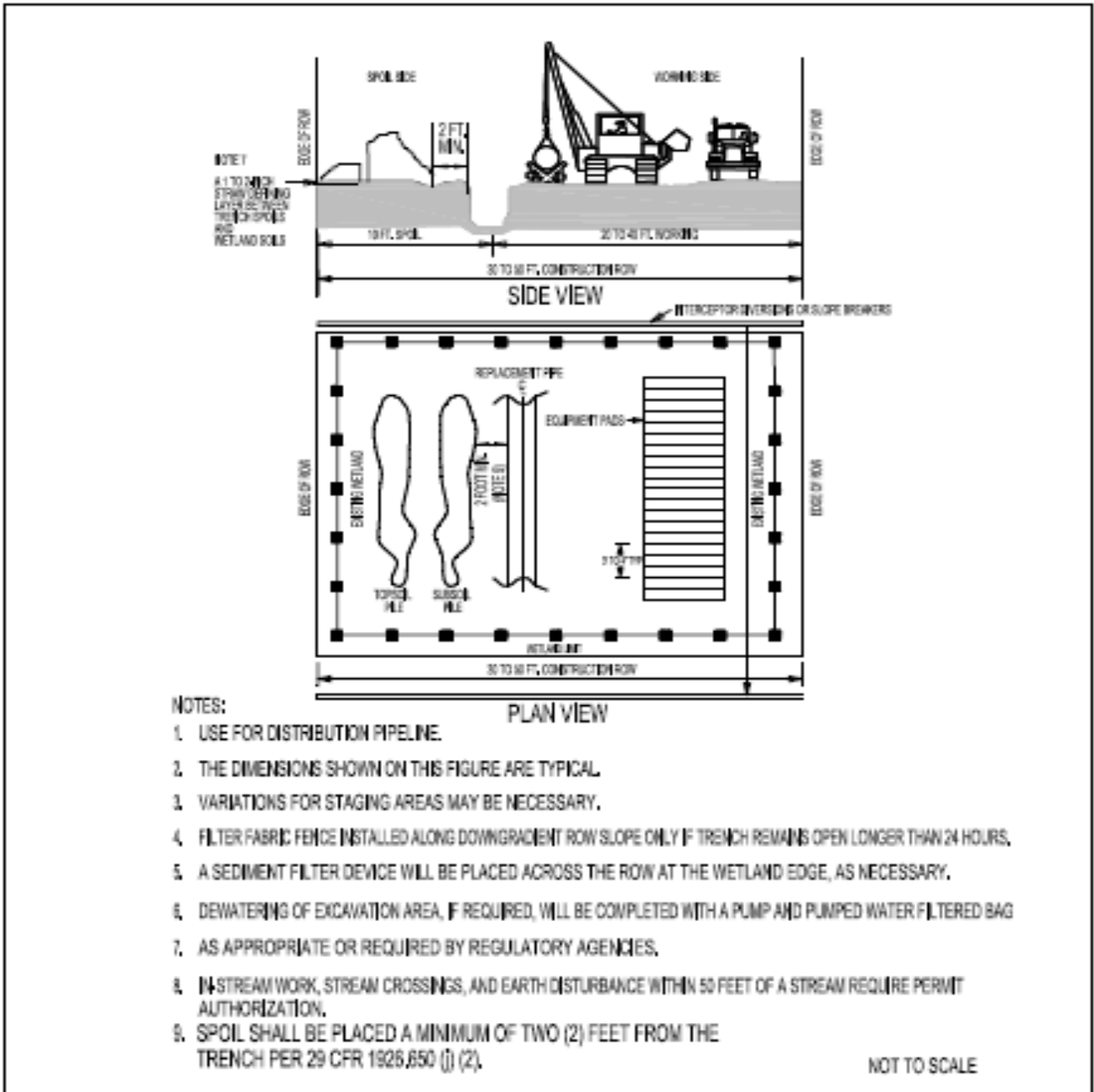


- NOTES:
1. DIRECTIONAL BORE STREAM AND WETLAND CROSSINGS ARE TO BE PREPARED AS ILLUSTRATED; HOWEVER ALTERNATIVE METHODS OR LAYOUTS CAN BE APPROVED.
  2. BORE RIG SHALL NOT BE SET UP IN A FLOODWAY OR WETLAND.
  3. SILT FENCE SHALL BE INSTALLED BETWEEN BORE PITS AND STREAM AND/OR WETLAND.
  4. SILT FENCE SHALL BE INSTALLED AS ILLUSTRATED IN FIGURE 4.
  5. IN THE EVENT OF A FRAC OUT IN A STREAM OR WETLAND, STRAW BALES SHALL BE INSTALLED TO CONTAIN MUD.
  6. PRIOR TO THE COMPLETION OF THE PROJECT, ALL HAY BALES AND MUD SHALL BE REMOVED FROM THE PROJECT AREA.
  7. ALL SILT FENCE SHALL BE REMOVED UPON SUCCESSFUL REVEGETATION OF THE PROJECT AREA.
  8. IN-STREAM WORK, STREAM CROSSINGS, AND EARTH DISTURBANCE WITHIN 50 FEET OF A STREAM REQUIRE PERMIT AUTHORIZATION.

|   |   |                    |
|---|---|--------------------|
| <br><b>NI SOURCE</b><br>GAS DISTRIBUTION<br>ENVIRONMENTAL CONSTRUCTION STANDARDS | <b>DIRECTIONAL BORE<br/>         STREAM &amp; WETLAND<br/>         CROSSING</b> | <b>FIGURE - 23</b> |
|---|---|--------------------|

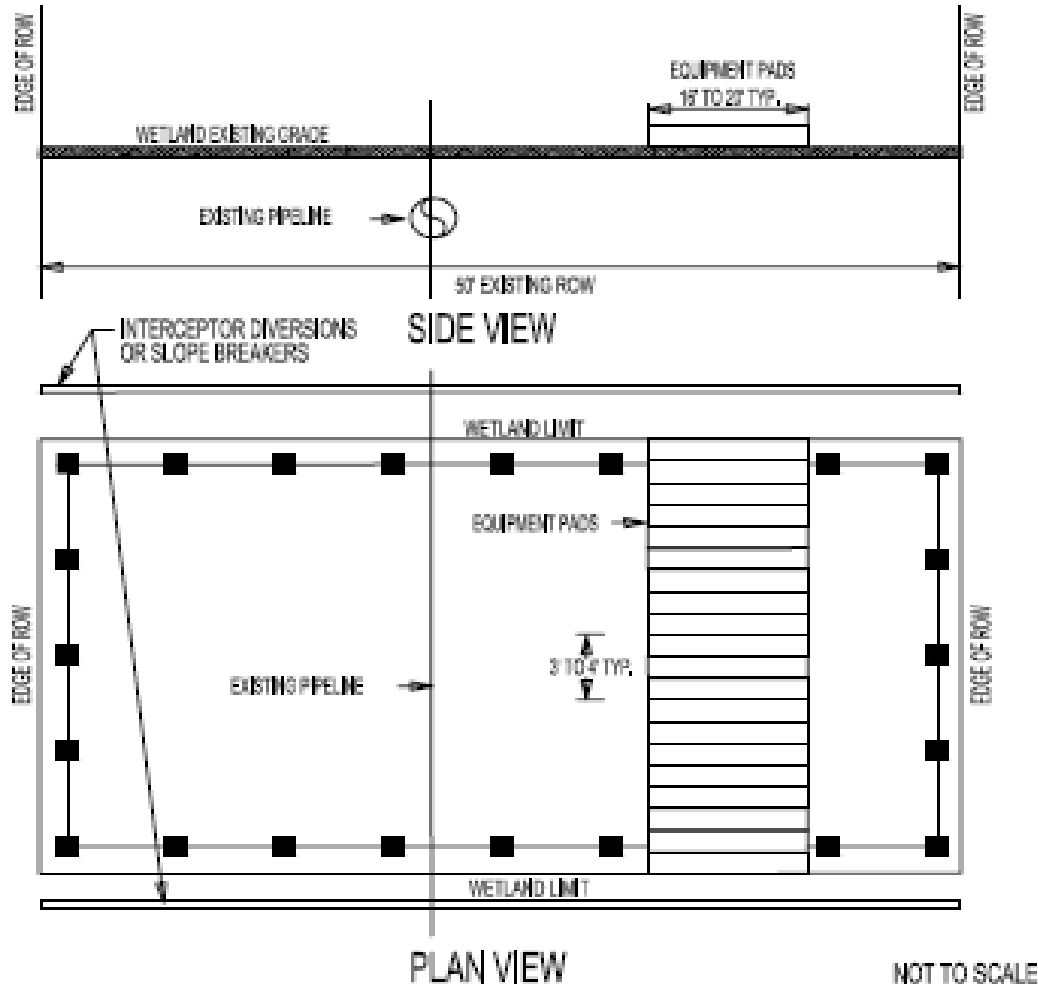


|                             |  |   |
|-----------------------------|--|---|
| Effective Date:<br>7/1/2014 | <b>Environmental Construction Standard</b> | Standard Number:<br><b>HSE 4440.020</b> |
| Supersedes:<br>11/1/2013    |  | Page 66 of 69                           |




|   |                                 |             |
|---|---------------------------------|-------------|
| <br><b>NISOURCE</b><br>GAS DISTRIBUTION<br>ENVIRONMENTAL CONSTRUCTION STANDARDS | TYPICAL WETLAND<br>CONSTRUCTION | FIGURE - 24 |
|---|---------------------------------|-------------|

|                             |  |   |
|-----------------------------|--|---|
| Effective Date:<br>7/1/2014 | <b>Environmental Construction Standard</b> | Standard Number:<br><b>HSE 4440.020</b> |
| Supersedes:<br>11/1/2013    |  | Page 67 of 69                           |



**NOTES:**

1. EQUIPMENT PADS WILL BE USED TO PROVIDE STABLE WETLAND CROSSING AND ACCESS WHEN SOIL CONDITIONS WILL NOT SUPPORT EQUIPMENT WEIGHT.
2. PADS ARE TYPICALLY 3 TO 4 FT. WIDE, 16 TO 20 FT. LONG AND 8 INCHES TO 1 FT. THICK. DIMENSIONS CAN VARY DEPENDING ON SITE CONDITIONS.
3. A SEDIMENT FILTER DEVICE WILL BE PLACED ACROSS THE ROW AT THE WETLAND EDGE, AS NECESSARY.

|  |  |                    |
|--|--|--------------------|
| <br><b>NISOURCE</b><br>GAS DISTRIBUTION<br>ENVIRONMENTAL CONSTRUCTION STANDARDS | <b>STABLE<br/>WETLAND<br/>CROSSING</b> | <b>FIGURE - 25</b> |
|--|--|--------------------|



|                             |  |   |
|-----------------------------|--|---|
| Effective Date:<br>7/1/2014 | <b>Environmental Construction Standard</b> | Standard Number:<br><b>HSE 4440.020</b> |
| Supersedes:<br>11/1/2013    |  | Page 68 of 69                           |

Figure 25: Temporary Wetland Equipment Crossing – Tire Mat



(Figure credit: University of Minnesota FS-7013)

Notes: Tire mats may be purchased commercially or built by interconnecting tire sidewalls with corrosion-resistant fasteners. Size mats according to site needs.

Smooth out any high spots and fill ruts. Do not disturb the root mat of vegetation because it provides additional support for the crossing.

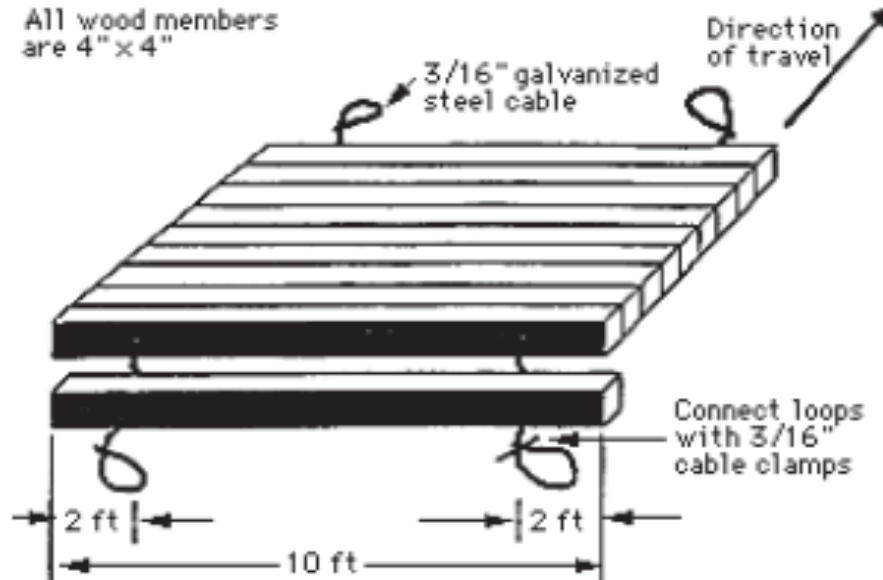
**IN-STREAM WORK, STREAM CROSSINGS, AND EARTH DISTURBANCE WITHIN 50 FEET OF A STREAM REQUIRE PERMIT AUTHORIZATION.**

NOT TO SCALE

|   |   |             |
|---|---|-------------|
| <br>NiSOURCE<br>GAS DISTRIBUTION<br>ENVIRONMENTAL CONSTRUCTION STANDARDS | TEMPORARY WETLAND<br>EQUIPMENT CROSSING<br>TIRE MAT | FIGURE - 26 |
|---|---|-------------|

|                             |  |   |
|-----------------------------|--|---|
| Effective Date:<br>7/1/2014 | <b>Environmental Construction Standard</b> | Standard Number:<br><b>HSE 4440.020</b> |
| Supersedes:<br>11/1/2013    |  | Page 69 of 69                           |

Figure 26: Temporary Wetland Equipment Crossing – Wood Mat



(Figure credit: University of Minnesota FS-7009)

Notes: Mats are made from logs or sawn hardwood and are cabled together to form a single layer crossing. Longer logs are more useful in the case of a heavy load or very loose soil.

Wood mats can be constructed on site and are easy to build and maintain. Under normal use, a wood mat is expected to last for several years. Individual wood mats can be connected to construct a complete crossing.

In-stream work, stream crossings, and earth disturbance within 50 feet of a stream require permit authorization.

NOT TO SCALE



TEMPORARY WETLAND  
EQUIPMENT CROSSING  
WOOD MAT

FIGURE • 27



**Health, Safety and Environmental Standard**

**Distribution Operations**

|                               |  |   |
|-------------------------------|--|---|
| Effective Date:<br>05/01/2012 | <b>Spoil Handling During Excavations</b> | Standard Number:<br><b>HSE 4440.030(KY)</b> |
| Supersedes:<br>N/A            |  | Page 1 of 8                                 |

Companies Affected:

|                                 |   |                              |
|---------------------------------|---|------------------------------|
| <input type="checkbox"/> NIPSCO | <input type="checkbox"/> CGV            | <input type="checkbox"/> CMD |
|                                 | <input checked="" type="checkbox"/> CKY | <input type="checkbox"/> COH |
|                                 | <input type="checkbox"/> CMA            | <input type="checkbox"/> CPA |

**REFERENCE** EXHIBIT B, EPA Letter Dated June 11, 1992

**1. SCOPE**

This Procedure is designed to ensure that excess spoils from NiSource Gas Distribution company operations are properly managed.

This document is to be used by field personnel when excavating Spoils from a project site and by HSE coordinators when handling Spoils generated as a result of excavation activities conducted on easements, rights-of-way, and other non-owned project locations.

Contaminated Spoils may be encountered when excavating sites, for example when excavating in a public right-of-way. Contaminated Spoils may contain some compounds that are considered environmentally hazardous and may also pose a health hazard to NiSource employees if exposure is over a long period of time or above a threshold value. Section 5 of this Standard will walk through the steps necessary to determine whether Spoils are contaminated.

Disposal and reuse of Excess Spoils shall comply with all local, state, and federal regulations to prevent environmental impact associated with such practices.

**2. DEFINITIONS**

**Approved, Permitted Waste Facility:** A facility that is authorized to accept regulated material for disposal, recycling, or processing pursuant to a permit from the appropriate state authority and approved by NiSource’s waste management provider.

**Contaminated Spoils:** For the purpose of this Standard, Spoils are contaminated if Company personnel have determined that the Spoils are contaminated by completing the steps in Section 5.2.2 of this Standard.

**Construction/Demolition Debris:** Any material resulting from construction, remodeling, repair and demolition, including, but not limited to asphalt, brick, concrete, rebar, rock, stone, glass, insulation, gravel, and plaster.

**Excess Spoils:** Any material that is removed from an excavation site and that will not be used as backfill.

*This document is considered CONTROLLED only when viewed electronically on the Company’s intranet. Printed or other electronic copies may not be current, and the intranet version should be used to verify.*



**Distribution Operations**

**Health, Safety and Environmental Standard**

|                               |  |   |
|-------------------------------|--|---|
| Effective Date:<br>05/01/2012 | <b>Spoil Handling During Excavations</b> | Standard Number:<br><b>HSE 4440.030(KY)</b> |
| Supersedes:<br>N/A            |  | Page 2 of 8                                 |

**Hazardous Waste:** Any Solid Waste that is regulated as “hazardous” under federal, state, or local law.

**Solid Waste:** Any discarded material, including solid, liquid, semisolid, or contained gaseous material resulting from industrial, commercial, mining, or agricultural operations or from community activities.

**Spoils:** Any material excavated from a construction or maintenance work area.

**Soil:** Any earthen material consisting of rock and mineral particles and organic material, but which does not contain Solid Waste, Hazardous Waste, or Construction/Demolition Debris.

**3. RESPONSIBILITIES**

**3.1 Excess Spoils**

It is the responsibility of local management to properly manage Excess Spoils in compliance with this Standard and communicate the requirements to their employees.

All NiSource Gas Distribution employees engaged in activities that may generate Excess Spoils shall be familiar with and understand the spoils management requirements that apply to their local operations.

The Health, Safety, and Environmental (HSE) Department is responsible for ongoing monitoring of spoils management practices and disposal location suitability.

**3.2 Contaminated Spoils**

Employees who encounter potentially Contaminated Spoils during excavation are responsible for notifying their immediate supervisor, who will in turn contact the appropriate HSE Coordinator.

It is the responsibility of HSE Coordinator to implement this Standard and maintain proper documentation, such as sampling data and waste disposal records. If Contaminated Spoils are present or suspected, then the HSE Coordinator is also responsible for notifying the property owner and appropriate environmental agency, if necessary.

**4. EXCESS SPOILS**

**4.1 Determine what materials are contained in the Excess Spoils.**

- a. If the Excess Spoils contain Soil only, proceed to Section 5.
- b. If the Excess Spoils contain any amount of Solid Waste, the Excess Spoils must be properly disposed of at an Approved, Permitted Waste Facility. If an alternate waste facility is requested, NiSource’s waste management



**Distribution Operations**

**Health, Safety and Environmental Standard**

|                               |  |   |
|-------------------------------|--|---|
| Effective Date:<br>05/01/2012 | <b>Spoil Handling During Excavations</b> | Standard Number:<br><b>HSE 4440.030(KY)</b> |
| Supersedes:<br>N/A            |  | Page 3 of 8                                 |

provider must be contacted and a request for a waste audit should be completed. However, to the extent that the Solid Waste can be segregated from the Soil and/or Construction/Demolition Debris, the Soil and/or Construction/Demolition Debris can be disposed of or reused pursuant to this Standard and the segregated Solid Waste can be disposed of at an Approved, Permitted Waste Facility. If an alternate waste facility is requested, NiSource’s waste management provider must be contacted and a request for a waste audit should be completed.

- c. If the Excess Spoils contain any amount of Hazardous Waste, the Excess Spoils must be properly disposed of at an Approved, Permitted Waste Facility. If an alternate waste facility is requested, NiSource’s waste management provider must be contacted and a request for a waste audit should be completed.
- d. If the Excess Spoils contain Construction/Demolition Debris, proceed to Section 5.
- e. If the Excess Spoils contain a **mixture** of Soil and Construction/Demolition Debris and the two materials cannot be segregated, consider the Excess Spoils “Construction/Demolition Debris” for purposes of this Standard and proceed to Section 5.

**5. CONTAMINATED SPOILS HANDLING PROCEDURES**

This Section will walk through the steps required to determine whether Spoils are contaminated. If Spoils are contaminated, they must be disposed of pursuant to the following provisions. If Spoils are not contaminated, you may follow the attached state-specific procedure for the use of “clean fill,” attached as Exhibit A.

**5.1 Operations Personnel**

All sites should have proper environmental clearances prior to any planned excavation. These clearances are required whenever new right of way is secured. NiSource Land Agents complete this process (known as the Land Rights Transfer [LRT] process) along with the HSE Department. Often excavation occurs in existing utility right-of-ways (such as replacement projects), which may not be included in the clearance process. Prior environmental clearance may not be possible in an emergency situation.

If gross physical contamination is found or if field employees feel that there is a potential issue, all work shall stop and the work site will be made safe. The employees should then promptly notify their immediate supervisor. The supervisor will immediately contact the appropriate HSE Coordinator for guidance.

Observations of gross physical contamination include the following:

- a. Odor (i.e. gasoline, diesel, mercaptan odorant),



**Distribution Operations**

**Health, Safety and Environmental Standard**

|                               |  |   |
|-------------------------------|--|---|
| Effective Date:<br>05/01/2012 | <b>Spoil Handling During Excavations</b> | Standard Number:<br><b>HSE 4440.030(KY)</b> |
| Supersedes:<br>N/A            |  | Page 4 of 8                                 |

- b. Discoloration of soil. Contaminated soil is often darker in color than the surrounding soil,
- c. Pooling or collecting of liquids within the excavation with a rainbow-colored sheen (i.e. petroleum sheen),
- d. Presence of buried containers, such as drums.

In the event of contamination, removed Spoils may be returned to the excavation, if suitable as backfill. If Spoils are removed from the generation (or excavation) site, then the appropriate HSE Coordinator will be contacted prior removing any Spoils from the work location. Spoils that are to be removed from the site are to be stockpiled and protected from precipitation and erosion. Placing the impacted Spoils on and covering the Spoils with plastic to prevent contamination from moving offsite can accomplish this. The HSE Coordinator will then provide guidance as to any required analytical and special handling.

**5.2 HSE Personnel**

NiSource’s response to Contaminated Spoils will be determined by whether the Contaminated Spoils are being returned to the excavation site or removed offsite.

**5.2.1 Excavated Spoils that are returned to the excavation site or otherwise remain on-site.**

NiSource does not have environmental responsibility for Spoils that are returned to the excavation site. Excavating of spoils does not meet the definition of “waste generation”; therefore, NiSource is not responsible for the remediation of any contaminants. The appropriate state environmental agency should be notified of any gross contamination that is found. Gross contamination includes: free product, saturated Soils or Soils with strong odors and/or discoloration.

If Spoils will remain on-site or will be placed back into the excavation site and there are physical signs of contamination, the HSE Coordinator should contact the Land Agent, if the project is being done under the LRT process, to contact the property owner or contact the property owner directly.

**5.2.2 Spoils that are removed from the excavation site.**

If excavated Spoils are to be removed from a site, then NiSource is responsible for Spoils management and environmental contaminants found within the Spoils. The decision to test for possible contaminants will be based on several criteria:

- a. Physical signs of contamination:
  - Odor





**Distribution Operations**

## Health, Safety and Environmental Standard

|                               |  |   |
|-------------------------------|--|---|
| Effective Date:<br>05/01/2012 | <b>Spoil Handling During Excavations</b> | Standard Number:<br><b>HSE 4440.030(KY)</b> |
| Supersedes:<br>N/A            |  | Page 5 of 8                                 |

- Staining/discoloration
- b. Historical land use
- c. Expected end use of the removed soil (i.e. clean-fill, disposal, etc.)
- d. Presence of buried containers, such as drums

If the Spoils meet any of the above criteria then the Spoils should be tested to meet the criteria for waste characterization, classification and disposal. Spoils should be managed according to the test results to ensure proper handling and storage.

If it is determined that testing is not required, then the generating state's clean soil regulations (Exhibit A), if any, should be followed.

### 6. TRAINING

Employees shall be familiar with and understand the requirements of this Standard. Awareness training shall be completed by affected employees.

Refresher training shall be conducted at least every three (3) years.

### 7. RECORDS

#### 7.1 Records Retention

Records associated with excavated spoils such as sample data and waste disposal records are maintained by the HSE Coordinator.

All documents relating to the disposal or reuse of Spoils shall be retained for three (3) years.

All training sessions and dates of training shall be documented and recorded in the NiSource Learning Management System.



**Distribution Operations**

**Health, Safety and Environmental Standard**

|                               |  |   |
|-------------------------------|--|---|
| Effective Date:<br>05/01/2012 | <b>Spoil Handling During Excavations</b> | Standard Number:<br><b>HSE 4440.030(KY)</b> |
| Supersedes:<br>N/A            |  | Page 6 of 8                                 |

**EXHIBIT A  
(1 OF 3)**

**KENTUCKY**

**Management of Uncontaminated Soil and Construction and Demolition Debris Generated in Kentucky**

**1. DISPOSING OF UNCONTAMINATED EXCESS SPOILS**

Note that excess spoils shall not:

- a. Be mixed with Hazardous Waste, Solid Waste, or contaminated materials.
- b. Be placed in wetlands, either vegetated or water bodies.
- c. Be placed in designated flood zones.
- d. Be placed in any locally regulated resource area that is protected from filling activities.
- e. Excess spoils shall not be moved across states lines. Excess spoils shall remain in Kentucky. On occasion, when costs and risks dictate, an exemption to move spoils across state lines may be granted. Such an exemption must be approved by senior management and must be properly documented in accordance with Section 7 of GS 4440.030(KY).

Before disposing of or reusing excess spoils in Kentucky, contact the county to see if there are any additional local requirements for properly managing excess spoils. Otherwise, this Procedure may be followed.

**1.1 Uncontaminated Soil:**

**Kentucky** places no limits on the disposal or reuse of Uncontaminated Soil. You may use any one of the following options:

**1.1.1 Reuse the Uncontaminated Soil on site.**

Before any filling activity begins, the proposed fill site shall be inspected by a representative from the HSE Department to identify any environmental restrictions that may apply to the location.

**1.1.2 Reuse the Uncontaminated Soil off site at another Company-owned location.**

Before any filling activity begins, the proposed fill site shall be inspected by a representative from the HSE Department to identify any environmental restrictions that may apply to the location.





Distribution Operations

Heath, Safety and Environmental Standard

|                               |  |   |
|-------------------------------|--|---|
| Effective Date:<br>05/01/2012 | <b>Spoil Handling During Excavations</b> | Standard Number:<br><b>HSE 4440.030(KY)</b> |
| Supersedes:<br>N/A            |  | Page 7 of 8                                 |

**EXHIBIT A  
(2 OF 3)**

**1.1.3 Reuse the Uncontaminated Soil as daily cover at a permitted landfill.**

**1.1.4 Sell the Uncontaminated Soil for reuse elsewhere.**

**1.1.5 Reuse and manage the Uncontaminated Soil as uncontaminated fill in accordance with the following procedures:**

- a. Before any filling activity begins, the proposed fill site shall be inspected by a representative from the HSE Department to identify any environmental restrictions that may apply to the location.

**1.1.6 Dispose of the Uncontaminated Soil at an Approved, Permitted Waste Facility.**

Before shipping material to any type of facility, contact the facility to review what type of documentation must accompany the shipment. For example, most facilities will require testing. All test results shall be retained in accordance with the record retention policy in Section 7.

**1.2 Uncontaminated Construction/Demolition Debris:**

The Kentucky's definition of Construction/Demolition Debris is "waste resulting from the construction, remodeling, repair, and demolition of structures and roads and for the disposal of uncontaminated solid waste consisting of vegetation resulting from land clearing and grubbing, utility line maintenance, and season and storm related cleanup."

Note that in Kentucky the definition of **Construction/Demolition Debris** also includes **Land-Clearing Debris**. As a result, this Procedure may be followed for disposing of Land-Clearing Debris and Uncontaminated Construction/Demolition Debris. **Land-Clearing Debris** means vegetative matter that is cleared from a site or removed from a site following a seasonal or storm-related cleanup, including trees, brush, stumps, and other vegetation.

Kentucky places no limits on the disposal or reuse of Uncontaminated Construction/Demolition Debris so long as it is a Recovered Material. Under Kentucky law, "Recovered Material" means "those materials, including but not limited to compost, which have known current use, reuse, or recycling potential, which can be feasibly used, reused, or recycled, and which have been diverted or removed from the solid waste stream for sale, use, reuse, or recycling,..."



Distribution Operations

Health, Safety and Environmental Standard

|                               |  |   |
|-------------------------------|--|---|
| Effective Date:<br>05/01/2012 | <b>Spoil Handling During Excavations</b> | Standard Number:<br><b>HSE 4440.030(KY)</b> |
| Supersedes:<br>N/A            |  | Page 8 of 8                                 |

**EXHIBIT A  
(3 OF 3)**

One of the following options may be used:

**1.2.1 Reuse the Uncontaminated Construction/Demolition Debris on site.**

Before any filling activity begins, the proposed fill site shall be inspected by a representative from the HSE Department to identify any environmental restrictions that may apply to the location.

**1.2.2 Reuse the Uncontaminated Construction/Demolition Debris off site at another Company-owned site.**

Before any filling activity begins, the proposed fill site shall be inspected by a representative from the HSE Department to identify any environmental restrictions that may apply to the location.

**1.2.3 Reuse the Uncontaminated Construction/Demolition Debris as daily cover at a permitted landfill.**

**1.2.4 Sell the Uncontaminated Construction/Demolition Debris for reuse elsewhere.**

**1.2.5 Reuse and manage the Uncontaminated Construction/Demolition Debris as uncontaminated fill in accordance with the following procedures:**

Before any filling activity begins, the proposed fill site shall be inspected by a representative from the HSE Department to identify any environmental restrictions that may apply to the location.

**1.2.6 Dispose of the Uncontaminated Construction/Demolition Debris at an Approved, Permitted Waste Facility.**

Before shipping material to any type of facility, contact the facility to review what type of documentation must accompany the shipment. For example, most facilities will require testing. All test results shall be retained in accordance with the record retention policy in Section 7.

Faxback 11671

9441.1992(16)

United States Environmental Protection Agency  
Washington, D.C. 20460  
Office of Solid Waste and Emergency Response

June 11, 1992

Mr. Douglas H. Green  
Piper & Marbury  
1200 Nineteenth Street, N.W.  
Washington, D.C. 20036-2430

Dear Mr. Green:

Thank you for your letter of April 30, 1992, requesting clarification of the Environmental Protection Agency's (EPA's) interpretation of the applicability of certain Resource conservation and Recovery Act (RCRA) requirements to common excavation-type activities.

The particular situation which you presented in your letter involves excavation of soils, such as trenching operations for pipeline installation, where the soils may be hazardous by characteristic, or may contain listed hazardous wastes. We understand that your questions specifically relate to excavations being conducted on public roadways or at other similar locations that are not necessarily associated with or are part of a RCRA regulated treatment, storage, or disposal facility.

In the example which you cited in your letter, the soils from the excavation or construction activities are temporarily moved within the area of contamination, and subsequently redeposited into the same excavated area. In these situations, we agree that such activity does not constitute treatment, storage, or disposal of a hazardous waste under RCRA. The activity of placing waste in the ground would not normally meet the regulatory definitions of "treatment" or "storage" (40 CFR 260.10). In addition, as you noted in your letter, movement of wastes within an area of contamination



does not constitute "land disposal" and thus does not trigger RCRA hazardous waste disposal requirements (55 FR 8666, March 8, 1990). Thus, RCRA requirements such as land disposal restrictions would not apply.

With respect to generator requirements, as you indicated, a hazardous waste "generator" is one, by site, who produces a hazardous waste or first causes the waste to be regulated as hazardous (40 CFR 260.10). In the circumstances you described, the excavation does not "produce" the hazardous waste, nor does it subject the waste to hazardous waste regulation since, as discussed above, the activity you described is not "treatment," storage, or "land disposal" of hazardous waste. Therefore, we agree that the activity is not subject to any generator requirements.

Please let me know if you have any further questions regarding this issue.

Sincerely yours,  
Sylvia K. Lowrance, Director  
Office of Solid Waste

□



Health, Safety and Environmental Standard

Distribution Operations

|                               |  |   |
|-------------------------------|--|---|
| Effective Date:<br>07/01/2013 | <b>Reporting Greenhouse Gas Emissions - Leakage Survey Requirements at T-D Transfer Stations</b> | Standard Number:<br><b>HSE 4460.020</b> |
| Supersedes:<br>05/01/2012     |  | Page 1 of 15                            |

Companies Affected:

|  |   |   |
|--|---|---|
| <input checked="" type="checkbox"/> NIPSCO | <input checked="" type="checkbox"/> CGV | <input checked="" type="checkbox"/> CMD |
|  | <input checked="" type="checkbox"/> CKY | <input checked="" type="checkbox"/> COH |
|  | <input checked="" type="checkbox"/> CMA | <input checked="" type="checkbox"/> CPA |

**REFERENCE** Environmental Protection Agency 40 CFR Part 98, Subpart W-Petroleum and Natural Gas Systems; EPA Method 21 – Determination of Volatile Organic Compound Leaks (refer to Exhibit A)

**1. GENERAL**

As part of the Environmental Protection Agency (EPA) requirements to report greenhouse gas emissions, which includes methane (CH<sub>4</sub>) - the primary component of natural gas, a leakage survey shall be performed on the above grade **transmission-distribution (T-D) transfer stations** at least once each calendar year to determine leaking **components** that are operated by the Company.

Excluded from the requirements of this standard are customer meters and regulators, infrastructure, and pipelines (both interstate and intrastate) delivering natural gas directly to major industrial users, farm taps and tubing systems equal to or less than one half inch in diameter.

For the purposes of this procedure, a T-D transfer station includes stations where the Company operates facilities above grade at:

- a. a measured Point-of-Delivery (POD) or City Gate Station that contains measurement and/or regulation,
- b. an unmeasured POD or City Gate Station that contains regulation,
- c. a district regulator station served off of a transmission class (Company-owned) pipeline facility, and/or
- d. an exchange station, where the Company is taking gas from another distribution company's transmission pipeline into a the Company's distribution pipeline or system.

For the purposes of this procedure, a leak detector instrument reading of 10,000 ppm (1% methane gas in air) or greater designates a leak.

**2. DEFINITIONS**

For the purposes of this procedure, the following terms are defined.

*This document is considered CONTROLLED only when viewed electronically on the Company's intranet. Printed or other electronic copies may not be current, and the intranet version should be used to verify.*





Distribution Operations

Health, Safety and Environmental Standard

|                               |  |   |
|-------------------------------|--|---|
| Effective Date:<br>07/01/2013 | <b>Reporting Greenhouse Gas Emissions - Leakage Survey Requirements at T-D Transfer Stations</b> | Standard Number:<br><b>HSE 4460.020</b> |
| Supersedes:<br>05/01/2012     |  | Page 2 of 15                            |

“**Connector**” means flanged, screwed, or other joined fittings used to connect pipe line segments, tubing, pipe components (such as elbows, reducers, “T’s” or valves) or a pipeline and a piece of equipment or an instrument to a pipe, tube or piece of equipment. A common connector is a flange. Joined fittings welded completely around the circumference of the interface are not considered connectors for the purpose of this procedure.

“**Component**” means each metal to metal joint or seal of non-welded connection separated by a compression gasket, screwed thread (with or without thread sealing compound), metal to metal compression, or fluid barrier through which natural gas can escape to the atmosphere.

“**Distribution pipeline**” means a pipeline that is designated as such by the Pipeline and Hazardous Material Safety Administration (PHMSA) 49 CFR 192.3

“**Equipment leak**” means those emissions which could not reasonably pass through a stack, chimney, vent, or other functionally-equivalent opening.

“**Equipment leak detection**” means the process of identifying emissions from equipment, components, and other point sources.

“**Facility**” means the collection of all distribution pipelines, metering stations, and regulating stations that are operated by the Company.

“**Farm taps**” are pressure regulation stations that deliver gas directly from transmission pipelines to generally rural customers.

“**Metering-regulating stations**” means a station that meters the flowrate, regulates the pressure, or both, of natural gas in a natural gas distribution facility. This does not include customer meters, customer regulators, or farm taps.

“**Meter/regulator run**” means a series of components used in regulating pressure or metering natural gas flow or both.

“**Transmission-distribution (T-D) transfer station**” means a metering-regulating station where the Company takes part or all of the natural gas from a transmission pipeline and puts it into a distribution pipeline.

“**Transmission pipeline**” means a Federal Energy Regulatory Commission rate-regulated Interstate pipeline, a state rate-regulated Intrastate pipeline, or a pipeline that falls under the “Hinshaw Exemption” as referenced in the section 1(c) of the Natural Gas Act, 15 U.S.C. 717-717(w)(1994).

“**Tubing systems**” means piping equal to or less than one half inch diameter as per nominal pipe size.

“**Open-ended valve**” or “**open-ended lines (OELs)**” means any valve, except pressure



Distribution Operations

Health, Safety and Environmental Standard

|                               |  |   |
|-------------------------------|--|---|
| Effective Date:<br>07/01/2013 | <b>Reporting Greenhouse Gas Emissions - Leakage Survey Requirements at T-D Transfer Stations</b> | Standard Number:<br><b>HSE 4460.020</b> |
| Supersedes:<br>05/01/2012     |  | Page 3 of 15                            |

relief valves, having one side of the valve seat in contact with natural gas and one side open to atmosphere, either directly or through open piping.

**“Pressure relief device”** or **“pressure relief valve”** or **“pressure safety valve”** means a safety device used to prevent operating pressures from exceeding the maximum allowable operating pressure of the process equipment. A common pressure relief device is, but not limited, to a spring-loaded pressure relief valve. Devices that are actuated either by a pressure of less than or equal to 2.5 psig or by a vacuum are not pressure relief devices.

**“Valve”** means any device for halting or regulating the flow of a liquid or gas through a passage, pipeline, inlet, outlet, or orifice; including, but not limited to, gate, globe, plug, ball, butterfly and needle valves.

**3. SURVEY INSTRUMENT SPECIFICATIONS**

Survey instrument types that may meet the requirements of this procedure include, but are not limited to, catalytic oxidation, flame ionization, infrared absorption, and photoionization. The survey instrument used for the leakage surveys required by this procedure shall have the following functions:

- a. The instrument shall be capable of measuring a leak concentration of 10,000 ppm.
- b. The scale of the instrument meter shall be readable to  $\pm 2.5\%$  (i.e.,  $\pm 250$  ppm,  $\pm 0.5\%$  LEL,  $\pm 0.025\%$  gas) of a leak concentration.
- c. The instrument shall be equipped with an electrically driven pump to ensure that a sample is provided to the detector at a constant flow rate. The nominal sample flow rate, as measured at the sample probe tip, shall be 0.004 - 0.1 cu. ft. per min. when the probe is fitted with a glass wool plug or filter that may be used to prevent plugging of the instrument.
- d. The instrument shall be equipped with a probe or probe extension for sampling not to exceed ¼” in outside diameter, with a single end opening for admission of sample.
- e. The instrument shall be intrinsically safe for operation in explosive atmospheres as defined by the National Electrical Code by the National Fire Prevention Association or other applicable regulatory code for operation in any explosive atmospheres that may be encountered in its use. The instrument shall, at a minimum, be intrinsically safe for Class 1, Division 1 conditions, and/or Class 2, Division 1 conditions, as appropriate.
- f. The instrument shall not be operated with any safety device, such as an exhaust flame arrestor, removed.



Distribution Operations

Health, Safety and Environmental Standard

|                               |  |   |
|-------------------------------|--|---|
| Effective Date:<br>07/01/2013 | <b>Reporting Greenhouse Gas<br/>Emissions - Leakage Survey<br/>Requirements at T-D<br/>Transfer Stations</b> | Standard Number:<br><b>HSE 4460.020</b> |
| Supersedes:<br>05/01/2012     |  | Page 4 of 15                            |

**4. SURVEY INSTRUMENT CALIBRATION**

Calibrate the survey instrument for the requirements of this standard according to GS 1708.040 "Gas Detection Equipment Calibration and Operational Checks". If a modification to the sample pumping system or flow configuration (e.g., use of probe extension) is made or if instrument parts are replaced, the instrument must be calibrated prior to use. The calibration must meet the EPA Method 21 requirements (refer to Exhibit A).

**5. SURVEY METHOD**

An Exposed Piping Test shall be performed with an instrument, meeting the specifications in Section 3 above, over the above grade T-D transfer station components (emission sources as provided in Section 7 below) that are operated by the Company. Refer to GS 1708.030 "Leakage Survey and Test Methods," Section 2.5.1. The survey method must conform with 40 CFR Part 60, Appendix A-7, Method 21 (refer to Exhibit A).

For the purposes of this procedure, a leak detector instrument reading of 10,000 ppm (1% methane gas in air) or greater designates a leak.

Leaks found on tubing systems equal to or less than one half inch diameter are exempt from the reporting requirements of this procedure.

**6. SURVEY FREQUENCY**

The leakage survey shall be performed at each above grade T-D transfer station at least once each calendar year.

**7. EMISSION SOURCES**

Emission factors have been developed to estimate the leakage of various facility components, or emission sources, typically located within T-D transfer station. The leak survey must include meters, regulators and associated equipment at transmission-distribution transfer stations, including equipment leaks from:

- a. connectors,
- b. block valves,
- c. control valves,
- d. pressure relief valves,
- e. orifice meters,
- f. regulators, and
- g. open ended lines.





**Distribution Operations**

**Health, Safety and Environmental Standard**

|                               |  |   |
|-------------------------------|--|---|
| Effective Date:<br>07/01/2013 | <b>Reporting Greenhouse Gas Emissions - Leakage Survey Requirements at T-D Transfer Stations</b> | Standard Number:<br><b>HSE 4460.020</b> |
| Supersedes:<br>05/01/2012     |  | Page 5 of 15                            |

Customer meters and regulators and farm taps that physically deliver natural gas to end users are excluded from the requirements of this procedure.

**8. LEAK REPORTING REQUIREMENTS**

In addition to the requirements of GS 1714.010, GS 1714.010(KY), GS1714.010(OH) or GS 1714.010(PA) "Leakage Classification and Response," Form HSE 4460.020-1 "Report of Leaks Found at T-D Transfer Stations" (Refer to Exhibit B), the Company's work management system, or equivalent, shall be used to report leaks found during the leakage survey required by this procedure.

Completed reports shall be sent to the Company's Environmental Compliance Manager. Reports may be sent on a periodic basis throughout the calendar year; however, they shall be sent no later than January 31<sup>st</sup> of the year following the survey year.

Leaks found on facilities that are operated by another company shall be turned over to the other company. Refer to GS 1714.010, GS 1714.010(KY), GS 1714.010(OH) or GS 1714.010(PA) "Leakage Classification and Response" for additional guidance.

**9. RESPONSIBILITY**

The Systems Operations Department is responsible for ensuring that the leakage survey is completed and the results reported according to this procedure.

Environmental Compliance is responsible for calculating the total emissions, and compiling and submitting the required report to the EPA according to applicable procedures.

**10. RECORDS**

Form HSE 4460.020-1 "Report of Leaks Found at T-D Transfer Stations," or equivalent reports, shall be kept on file by the Company's Environmental Compliance Manager for 3 years, plus the current year.

Calibration records for instruments used for the purposes of this procedure shall be kept on file by local field operations in accordance with GS 1708.040 "Gas Detection Equipment Calibration and Operational Checks."



Health, Safety and Environmental Standard

Distribution Operations

|                               |  |   |
|-------------------------------|--|---|
| Effective Date:<br>07/01/2013 | <b>Reporting Greenhouse Gas Emissions - Leakage Survey Requirements at T-D Transfer Stations</b> | Standard Number:<br><b>HSE 4460.020</b> |
| Supersedes:<br>05/01/2012     |  | Page 6 of 15                            |

**EXHIBIT A  
(1 OF 9)**

**Method 21** Determination of Volatile Organic Compound Leaks

1.0 *Scope and Application*

1.1 Analytes.

| Analyte                          | CAS No.                 |
|----------------------------------|-------------------------|
| Volatile Organic Compounds (VOC) | No CAS number assigned. |

1.2 **Scope.** This method is applicable for the determination of VOC leaks from process equipment. These sources include, but are not limited to, valves, flanges and other connections, pumps and compressors, pressure relief devices, process drains, open-ended valves, pump and compressor seal system degassing vents, accumulator vessel vents, agitator seals, and access door seals.

1.3 **Data Quality Objectives.** Adherence to the requirements of this method will enhance the quality of the data obtained from air pollutant sampling methods.

2.0 *Summary of Method*

2.1 A portable instrument is used to detect VOC leaks from individual sources. The instrument detector type is not specified, but it must meet the specifications and performance criteria contained in Section 6.0. A leak definition concentration based on a reference compound is specified in each applicable regulation. This method is intended to locate and classify leaks only, and is not to be used as a direct measure of mass emission rate from individual sources.

3.0 *Definitions*

3.1 **Calibration gas** means the VOC compound used to adjust the instrument meter reading to a known value. The calibration gas is usually the reference compound at a known concentration approximately equal to the leak definition concentration.

3.2 **Calibration precision** means the degree of agreement between measurements of the same known value, expressed as the relative percentage of the average difference between the meter readings and the known concentration to the known concentration.



Health, Safety and Environmental Standard

Distribution Operations

|                               |  |   |
|-------------------------------|--|---|
| Effective Date:<br>07/01/2013 | <b>Reporting Greenhouse Gas<br/>Emissions - Leakage Survey<br/>Requirements at T-D<br/>Transfer Stations</b> | Standard Number:<br><b>HSE 4460.020</b> |
| Supersedes:<br>05/01/2012     |  | Page 7 of 15                            |

3.3 *Leak definition concentration* means the local VOC concentration at the surface of a leak source that indicates that a VOC emission (leak) is present. The leak definition is an instrument meter reading based on a reference compound.

3.4 *No detectable emission* means a local VOC concentration at the surface of a leak source, adjusted for local VOC ambient concentration that is less than 2.5 percent of the specified leak definition concentration that indicates that a VOC emission (leak) is not present.

3.5 *Reference compound* means the VOC species selected as the instrument calibration basis for specification of the leak definition concentration. (For example, if a leak definition concentration is 10,000 ppm as methane, then any source emission that results in a local concentration that yields a meter reading of 10,000 on an instrument meter calibrated with methane would be classified as a leak. In this example, the leak definition concentration is 10,000 ppm and the reference compound is methane.)

3.6 *Response factor* means the ratio of the known concentration of a VOC compound to the observed meter reading when measured using an instrument calibrated with the reference compound specified in the applicable regulation.

3.7 *Response time* means the time interval from a step change in VOC concentration at the input of the sampling system to the time at which 90 percent of the corresponding final value is reached as displayed on the instrument readout meter.

4.0 *Interferences [Reserved]*

5.0 *Safety*

5.1 **Disclaimer.** This method may involve hazardous materials, operations, and equipment. This test method may not address all of the safety problems associated with its use. It is the responsibility of the user of this test method to establish appropriate safety and health practices and determine the applicability of regulatory limitations prior to performing this test method.

5.2 **Hazardous Pollutants.** Several of the compounds, leaks of which may be determined by this method, may be irritating or corrosive to tissues ( e.g., heptane) or may be toxic ( e.g., benzene, methyl alcohol). Nearly all are fire hazards. Compounds in emissions should be determined through familiarity with the source. Appropriate precautions can be found in reference documents, such as reference No. 4 in Section 16.0.

6.0 *Equipment and Supplies*



Distribution Operations

Health, Safety and Environmental Standard

|                               |  |   |
|-------------------------------|--|---|
| Effective Date:<br>07/01/2013 | <b>Reporting Greenhouse Gas<br/>Emissions - Leakage Survey<br/>Requirements at T-D<br/>Transfer Stations</b> | Standard Number:<br><b>HSE 4460.020</b> |
| Supersedes:<br>05/01/2012     |  | Page 8 of 15                            |

A VOC monitoring instrument meeting the following specifications is required:

- 6.1 The VOC instrument detector shall respond to the compounds being processed. Detector types that may meet this requirement include, but are not limited to, catalytic oxidation, flame ionization, infrared absorption, and photoionization.
- 6.2 The instrument shall be capable of measuring the leak definition concentration specified in the regulation.
- 6.3 The scale of the instrument meter shall be readable to  $\pm 2.5$  percent of the specified leak definition concentration.
- 6.4 The instrument shall be equipped with an electrically driven pump to ensure that a sample is provided to the detector at a constant flow rate. The nominal sample flow rate, as measured at the sample probe tip, shall be 0.10 to 3.0 l/min (0.004 to 0.1 ft<sup>3</sup>/min) when the probe is fitted with a glass wool plug or filter that may be used to prevent plugging of the instrument.
- 6.5 The instrument shall be equipped with a probe or probe extension or sampling not to exceed 6.4 mm (1/4in) in outside diameter, with a single end opening for admission of sample.
- 6.6 The instrument shall be intrinsically safe for operation in explosive atmospheres as defined by the National Electrical Code by the National Fire Prevention Association or other applicable regulatory code for operation in any explosive atmospheres that may be encountered in its use. The instrument shall, at a minimum, be intrinsically safe for Class 1, Division 1 conditions, and/or Class 2, Division 1 conditions, as appropriate, as defined by the example code. The instrument shall not be operated with any safety device, such as an exhaust flame arrestor, removed.

7.0 *Reagents and Standards*

- 7.1 Two gas mixtures are required for instrument calibration and performance evaluation:
  - 7.1.1 Zero Gas. Air, less than 10 parts per million by volume (ppmv) VOC.
  - 7.1.2 Calibration Gas. For each organic species that is to be measured during individual source surveys, obtain or prepare a known standard in air at a concentration approximately equal to the applicable leak definition specified in the regulation.
- 7.2 Cylinder Gases. If cylinder calibration gas mixtures are used, they must be analyzed and certified by the manufacturer to be within 2 percent accuracy, and a



Distribution Operations

Health, Safety and Environmental Standard

|                               |  |   |
|-------------------------------|--|---|
| Effective Date:<br>07/01/2013 | <b>Reporting Greenhouse Gas Emissions - Leakage Survey Requirements at T-D Transfer Stations</b> | Standard Number:<br><b>HSE 4460.020</b> |
| Supersedes:<br>05/01/2012     |  | Page 9 of 15                            |

shelf life must be specified. Cylinder standards must be either reanalyzed or replaced at the end of the specified shelf life.

7.3 Prepared Gases. Calibration gases may be prepared by the user according to any accepted gaseous preparation procedure that will yield a mixture accurate to within 2 percent. Prepared standards must be replaced each day of use unless it is demonstrated that degradation does not occur during storage.

7.4 Mixtures with non-Reference Compound Gases. Calibrations may be performed using a compound other than the reference compound. In this case, a conversion factor must be determined for the alternative compound such that the resulting meter readings during source surveys can be converted to reference compound results.

8.0 *Sample Collection, Preservation, Storage, and Transport*

8.1 Instrument Performance Evaluation. Assemble and start up the instrument according to the manufacturer's instructions for recommended warmup period and preliminary adjustments.

8.1.1 Response Factor. A response factor must be determined for each compound that is to be measured, either by testing or from reference sources. The response factor tests are required before placing the analyzer into service, but do not have to be repeated at subsequent intervals.

8.1.1.1 Calibrate the instrument with the reference compound as specified in the applicable regulation. Introduce the calibration gas mixture to the analyzer and record the observed meter reading. Introduce zero gas until a stable reading is obtained. Make a total of three measurements by alternating between the calibration gas and zero gas. Calculate the response factor for each repetition and the average response factor.

8.1.1.2 The instrument response factors for each of the individual VOC to be measured shall be less than 10 unless otherwise specified in the applicable regulation. When no instrument is available that meets this specification when calibrated with the reference VOC specified in the applicable regulation, the available instrument may be calibrated with one of the VOC to be measured, or any other VOC, so long as the instrument then has a response factor of less than 10 for each of the individual VOC to be measured.

8.1.1.3 Alternatively, if response factors have been published for the compounds of interest for the instrument or detector type, the response factor determination is not required, and existing results



Distribution Operations

Health, Safety and Environmental Standard

|                               |  |   |
|-------------------------------|--|---|
| Effective Date:<br>07/01/2013 | <b>Reporting Greenhouse Gas Emissions - Leakage Survey Requirements at T-D Transfer Stations</b> | Standard Number:<br><b>HSE 4460.020</b> |
| Supersedes:<br>05/01/2012     |  | Page 10 of 15                           |

may be referenced. Examples of published response factors for flame ionization and catalytic oxidation detectors are included in References 1-3 of Section 17.0.

8.1.2 Calibration Precision. The calibration precision test must be completed prior to placing the analyzer into service and at subsequent 3-month intervals or at the next use, whichever is later.

8.1.2.1 Make a total of three measurements by alternately using zero gas and the specified calibration gas. Record the meter readings. Calculate the average algebraic difference between the meter readings and the known value. Divide this average difference by the known calibration value and multiply by 100 to express the resulting calibration precision as a percentage.

8.1.2.2 The calibration precision shall be equal to or less than 10 percent of the calibration gas value.

8.1.3 Response Time. The response time test is required before placing the instrument into service. If a modification to the sample pumping system or flow configuration is made that would change the response time, a new test is required before further use.

8.1.3.1 Introduce zero gas into the instrument sample probe. When the meter reading has stabilized, switch quickly to the specified calibration gas. After switching, measure the time required to attain 90 percent of the final stable reading. Perform this test sequence three times and record the results. Calculate the average response time.

8.1.3.2 The instrument response time shall be equal to or less than 30 seconds. The instrument pump, dilution probe (if any), sample probe, and probe filter that will be used during testing shall all be in place during the response time determination.

8.2 Instrument Calibration. Calibrate the VOC monitoring instrument according to Section 10.0.

8.3 Individual Source Surveys.

8.3.1 Type I-Leak Definition Based on Concentration. Place the probe inlet at the surface of the component interface where leakage could occur. Move the probe along the interface periphery while observing the instrument readout. If an increased meter reading is observed, slowly sample the interface where leakage is indicated until the maximum meter reading is obtained. Leave the probe inlet at



Distribution Operations

Health, Safety and Environmental Standard

|                               |  |   |
|-------------------------------|--|---|
| Effective Date:<br>07/01/2013 | <b>Reporting Greenhouse Gas Emissions - Leakage Survey Requirements at T-D Transfer Stations</b> | Standard Number:<br><b>HSE 4460.020</b> |
| Supersedes:<br>05/01/2012     |  | Page 11 of 15                           |

this maximum reading location for approximately two times the instrument response time. If the maximum observed meter reading is greater than the leak definition in the applicable regulation, record and report the results as specified in the regulation reporting requirements. Examples of the application of this general technique to specific equipment types are:

- 8.3.1.1 Valves. The most common source of leaks from valves is the seal between the stem and housing. Place the probe at the interface where the stem exits the packing gland and sample the stem circumference. Also, place the probe at the interface of the packing gland take-up flange seat and sample the periphery. In addition, survey valve housings of multipart assembly at the surface of all interfaces where a leak could occur.
- 8.3.1.2 Flanges and Other Connections. For welded flanges, place the probe at the outer edge of the flange-gasket interface and sample the circumference of the flange. Sample other types of nonpermanent joints (such as threaded connections) with a similar traverse.
- 8.3.1.3 Pumps and Compressors. Conduct a circumferential traverse at the outer surface of the pump or compressor shaft and seal interface. If the source is a rotating shaft, position the probe inlet within 1 cm of the shaft-seal interface for the survey. If the housing configuration prevents a complete traverse of the shaft periphery, sample all accessible portions. Sample all other joints on the pump or compressor housing where leakage could occur.
- 8.3.1.4 Pressure Relief Devices. The configuration of most pressure relief devices prevents sampling at the sealing seat interface. For those devices equipped with an enclosed extension, or horn, place the probe inlet at approximately the center of the exhaust area to the atmosphere.
- 8.3.1.5 Process Drains. For open drains, place the probe inlet at approximately the center of the area open to the atmosphere. For covered drains, place the probe at the surface of the cover interface and conduct a peripheral traverse.
- 8.3.1.6 Open-ended Lines or Valves. Place the probe inlet at approximately the center of the opening to the atmosphere.
- 8.3.1.7 Seal System Degassing Vents and Accumulator Vents. Place the probe inlet at approximately the center of the opening to the atmosphere.
- 8.3.1.8 Access door seals. Place the probe inlet at the surface of the door seal interface and conduct a peripheral traverse.





Distribution Operations

Health, Safety and Environmental Standard

|                               |  |   |
|-------------------------------|--|---|
| Effective Date:<br>07/01/2013 | <b>Reporting Greenhouse Gas Emissions - Leakage Survey Requirements at T-D Transfer Stations</b> | Standard Number:<br><b>HSE 4460.020</b> |
| Supersedes:<br>05/01/2012     |  | Page 12 of 15                           |

8.3.2 Type II-“No Detectable Emission”. Determine the local ambient VOC concentration around the source by moving the probe randomly upwind and downwind at a distance of one to two meters from the source. If an interference exists with this determination due to a nearby emission or leak, the local ambient concentration may be determined at distances closer to the source, but in no case shall the distance be less than 25 centimeters. Then move the probe inlet to the surface of the source and determine the concentration as outlined in Section 8.3.1. The difference between these concentrations determines whether there are no detectable emissions. Record and report the results as specified by the regulation. For those cases where the regulation requires a specific device installation, or that specified vents be ducted or piped to a control device, the existence of these conditions shall be visually confirmed. When the regulation also requires that no detectable emissions exist, visual observations and sampling surveys are required. Examples of this technique are:

8.3.2.1 Pump or Compressor Seals. If applicable, determine the type of shaft seal. Perform a survey of the local area ambient VOC concentration and determine if detectable emissions exist as described in Section 8.3.2.

8.3.2.2 Seal System Degassing Vents, Accumulator Vessel Vents, Pressure Relief Devices. If applicable, observe whether or not the applicable ducting or piping exists. Also, determine if any sources exist in the ducting or piping where emissions could occur upstream of the control device. If the required ducting or piping exists and there are no sources where the emissions could be vented to the atmosphere upstream of the control device, then it is presumed that no detectable emissions are present. If there are sources in the ducting or piping where emissions could be vented or sources where leaks could occur, the sampling surveys described in Section 8.3.2 shall be used to determine if detectable emissions exist.

8.3.3 Alternative Screening Procedure.

8.3.3.1 A screening procedure based on the formation of bubbles in a soap solution that is sprayed on a potential leak source may be used for those sources that do not have continuously moving parts, that do not have surface temperatures greater than the boiling point or less than the freezing point of the soap solution, that do not have open areas to the atmosphere that the soap solution cannot bridge, or that do not exhibit evidence of liquid leakage. Sources that have these conditions present must be surveyed using the instrument technique of Section 8.3.1 or 8.3.2.





**Health, Safety and Environmental Standard**

**Distribution Operations**

|                               |  |   |
|-------------------------------|--|---|
| Effective Date:<br>07/01/2013 | <b>Reporting Greenhouse Gas Emissions - Leakage Survey Requirements at T-D Transfer Stations</b> | Standard Number:<br><b>HSE 4460.020</b> |
| Supersedes:<br>05/01/2012     |  | Page 13 of 15                           |

8.3.3.2 Spray a soap solution over all potential leak sources. The soap solution may be a commercially available leak detection solution or may be prepared using concentrated detergent and water. A pressure sprayer or squeeze bottle may be used to dispense the solution. Observe the potential leak sites to determine if any bubbles are formed. If no bubbles are observed, the source is presumed to have no detectable emissions or leaks as applicable. If any bubbles are observed, the instrument techniques of Section 8.3.1 or 8.3.2 shall be used to determine if a leak exists, or if the source has detectable emissions, as applicable.

9.0 *Quality Control*

| Section | Quality control measure                | Effect   |
|---------|--|--|
| 8.1.2   | Instrument calibration precision check | Ensure precision and accuracy, respectively, of instrument response to standard. |
| 10.0    | Instrument calibration                 |  |

10.0 *Calibration and Standardization*

10.1 Calibrate the VOC monitoring instrument as follows. After the appropriate warm-up period and zero internal calibration procedure, introduce the calibration gas into the instrument sample probe. Adjust the instrument meter readout to correspond to the calibration gas value.

Note: If the meter readout cannot be adjusted to the proper value, a malfunction of the analyzer is indicated and corrective actions are necessary before use.

11.0 *Analytical Procedures [Reserved]*

12.0 *Data Analyses and Calculations [Reserved]*

13.0 *Method Performance [Reserved]*

14.0 *Pollution Prevention [Reserved]*

15.0 *Waste Management [Reserved]*

16.0 *References*

1. Dubose, D.A., and G.E. Harris. Response Factors of VOC Analyzers at a Meter Reading of 10,000 ppmv for Selected Organic Compounds. U.S. Environmental



**Health, Safety and Environmental Standard**

**Distribution Operations**

|                               |  |   |
|-------------------------------|--|---|
| Effective Date:<br>07/01/2013 | <b>Reporting Greenhouse Gas<br/>Emissions - Leakage Survey<br/>Requirements at T-D<br/>Transfer Stations</b> | Standard Number:<br><b>HSE 4460.020</b> |
| Supersedes:<br>05/01/2012     |  | Page 14 of 15                           |

Protection Agency, Research Triangle Park, NC. Publication No. EPA 600/2-81051. September 1981.

2. Brown, G.E., *et al.* Response Factors of VOC Analyzers Calibrated with Methane for Selected Organic Compounds. U.S. Environmental Protection Agency, Research Triangle Park, NC. Publication No. EPA 600/2-81-022. May 1981.
3. DuBose, D.A. *et al.* Response of Portable VOC Analyzers to Chemical Mixtures. U.S. Environmental Protection Agency, Research Triangle Park, NC. Publication No. EPA 600/2-81-110. September 1981.
4. Handbook of Hazardous Materials: Fire, Safety, Health. Alliance of American Insurers. Schaumburg, IL. 1983.

17.0 *Tables, Diagrams, Flowcharts, and Validation Data [Reserved]*





|                            |                                 |   |   |
|----------------------------|---------------------------------|---|---|
| <u>Companies Affected:</u> | <input type="checkbox"/> NIPSCO | <input type="checkbox"/> CGV            | <input checked="" type="checkbox"/> CMD |
|                            |                                 | <input checked="" type="checkbox"/> CKY | <input checked="" type="checkbox"/> COH |
|                            |                                 | <input checked="" type="checkbox"/> CMA | <input checked="" type="checkbox"/> CPA |

## WELDING MANUAL

03/07/2013



# NGD Welding Manual

- 1. Scope .....5**
- 2. Industry References .....5**
- 3. DEFINITIONS.....5**
- 4. Materials.....6**
  - 4.1 Pipe and Fittings.....6
  - 4.2 Pipe Wall Discontinuities .....7
    - 4.2.1 Pipe Ends.....7
    - 4.2.2 Laminations.....7
    - 4.2.3 Cracks.....7
    - 4.2.4 Dents.....7
    - 4.2.5 Gouges, Grooves, Scratches, and Notches.....7
  - 4.3 Pipe Bevel Discontinuities .....8
    - 4.3.1 Arc Burns .....8
    - 4.3.2 Laminations.....8
    - 4.3.3 Bevel Damage.....8
    - 4.3.4 Root Face Damage .....9
    - 4.3.5 Bevel Dents.....9
  - 4.4 Welded Closures .....9
  - 4.5 Flanges .....9
  - 4.6 O-let Fittings.....9
  - 4.7 Reuse/Reclamation Practices for Weld Flanges and Fittings.....9
    - 4.7.1 General Requirements .....9
    - 4.7.2 ANSI Weld Neck Flanges .....10
    - 4.7.3 MSS Flanges.....11
    - 4.7.4 Caps and Reducers.....11
    - 4.7.5 ANSI Elbows .....11
    - 4.7.6 Tees .....11
    - 4.7.7 Other Butt-Weld Fittings .....11
  - 4.8 Filler Metal.....11
    - 4.8.1 Type and Size .....11
    - 4.8.2 Storage and Handling of Filler Metals and Fluxes.....12
    - 4.8.3 Filler Metal Groups .....12
- 5. Qualification of Welding Procedures for Welds Containing Filler-metal Additives .....13**
  - 5.1 Procedure Qualifications .....13
  - 5.2 Welding Procedure Specification Testing .....13
    - 5.2.1 Butt Welds Tests .....13



# NGD Welding Manual

- 5.2.2 Fillet Welds Test..... 13
- 5.3 Records..... 13
- 5.4 Process ..... 13
- 5.5 Base Metal, Diameter and Wall Thickness Groups..... 14
  - 5.5.1 Base Metal Groupings ..... 14
  - 5.5.2 Diameter..... 14
  - 5.5.3 Wall Thickness ..... 14
- 5.6 Joint Design ..... 14
- 5.7 ESSENTIAL VARIABLES ..... 15
- 6. Qualification of Welders..... 15**
  - 6.1 Initial Qualifications ..... 15
  - 6.2 Testing of Qualification Welds ..... 16
    - 6.2.1 Visual ..... 16
    - 6.2.2 Destructive Testing..... 16
  - 6.3 Required Welder Qualifying Tests for Shield Metal Arc Welding (SMAW) and Gas Metal Arc Welding (GMAW) ..... 16
    - 6.3.1 Service Welder Test ..... 16
    - 6.3.2 Pipeline Welder Test ..... 16
    - 6.3.3 In-service Welder Test..... 16
  - 6.4 Required Welder Qualifying Tests for Oxyactylene Welding (OAW) ..... 17
  - 6.5 Structural Welder Qualifications..... 17
    - 6.5.1 Structural Weld Tests ..... 18
  - 6.6 Welding Permits ..... 18
  - 6.7 Six-month Requalification Requirements ..... 18
  - 6.8 RECORDS ..... 19
    - 6.8.1 Company Forms/Database..... 19
    - 6.8.2 Records Retention..... 19
- 7. Production Welding..... 19**
  - 7.1 Depolarization ..... 20
  - 7.2 Alignment ..... 20
    - 7.2.1 Butt Welds..... 20
    - 7.2.2 Line-up Clamps ..... 20
    - 7.2.3 Tack Welds ..... 21
    - 7.2.4 Socket Welds ..... 21
    - 7.2.5 Slip-on Flanges ..... 21
  - 7.3 Bevels ..... 21



# NGD Welding Manual

- 7.3.1 Mill Bevel ..... 22
- 7.3.2 Field Bevel ..... 22
- 7.4 Weather Conditions ..... 22
- 7.5 Cleaning and Grinding ..... 22
- 7.6 Filler and Finish Beads ..... 23
- 7.7 Identification of Welders ..... 23
- 7.8 Minimum Number of Welders ..... 23
- 7.9 Minimum Distance between Welds ..... 23
- 7.10 Transition Joints ..... 24
- 7.11 Weld Joint Clearance ..... 24
- 7.12 Preheating of Welds ..... 24
- 8. Inspection of Welds..... 25**
  - 8.1 Visual Inspection of Welds..... 25
  - 8.2 Non-Destructive Testing Personnel ..... 25
  - 8.3 Records ..... 26
- 9. Weld Repair..... 26**
  - 10.1 Cracks ..... 27
  - 10.2 Arc Burns ..... 27
- 10. Safety..... 27**
  - 10.1 General Area ..... 27
  - 10.2 Eye and Face Protection ..... 27
  - 10.3 Protective Clothing ..... 28
  - 10.4 Ventilation ..... 28
  - 10.5 Fire Prevention and Protection ..... 29
  - 10.6 Welding Equipment ..... 29
    - 10.6.1 Oxy-fuel Welding and Cutting Equipment ..... 29
    - 10.6.2 Welding Machine and Associated Equipment ..... 30
  - 10.7 Power Tools ..... 30
  - 10.8 Gas Cylinders ..... 30
- 11. In-service Welding..... 31**
  - 11.1 Design Limitations ..... 31
    - 11.1.1 Location and Position ..... 31
    - 11.1.2 Design Pressure ..... 31
    - 11.1.3 Branch Reinforcement Members ..... 31
  - 11.2 Preliminary Steps ..... 32
  - 11.3 Welding ..... 32



# NGD Welding Manual

|   |   |    |
|---|---|----|
| 11.3.1                                      | Non-encirclement Reinforcement and Fittings ..... | 32 |
| 11.3.2                                      | Type A Full-encirclement Fittings .....           | 32 |
| 11.3.3                                      | Type B Full-encirclement Fittings .....           | 32 |
| 11.3.4                                      | Pressure Testing .....                            | 33 |
| APPENDIX A Industry References              |   | 56 |
| APPENDIX B Welding Procedure Specifications |   | 59 |





# NGD Welding Manual

## 1. SCOPE

This manual includes the welding specifications and procedures to be used for the construction, fabrication, and maintenance on all pipeline facilities, including casings, within the Companies of NiSource Distribution Operations (Company). All Company and contractor personnel performing work for the Company shall follow the specifications and procedures presented herein. This manual provides the requirements for welder qualification using the Shielded Metal Arc (SMAW), Gas Metal Arc (GMAW) Sub-arc (SAW) and Oxy-acetylene (OAW) welding processes. GMAW is restricted to fabrication shop welding only.

All welding shall meet the requirements set forth in the Department of Transportation, Code of Federal Regulations, Title 49, Part 192. This manual will be updated as required to maintain current revisions of the referenced codes and standards. The welding manual, procedure qualification records and welding procedure specification adhere to the requirements set forth in API 1104 Twentieth Edition.

All pipe welds shall be made in accordance with qualified Welding Procedure Specifications. Appendix B contains qualified Welding Procedure Specifications using the SMAW and OAW processes

## 2. INDUSTRY REFERENCES

See Appendix A for a list of Industry References.

## 3. DEFINITIONS

“ASME Piping” means any piping system designed in accordance with an American Society of Mechanical Engineers (ASME) Code. These piping systems require welding procedure and welder qualification in accordance with ASME Section IX requirements.

“ANSI” means American National Standards Institute.

“API” means American Petroleum Institute.

“Branch Weld” means the complete groove and/or fillet weld joining a set on or set in branch pipe or a set in or set on branch fitting to a run pipe.

“Company Welder” means a Company employee who has been qualified to perform specific welding services on Company pipeline facilities.

“Confined Space” is a space that has limited or restricted means of entry and exit, has adequate size and configuration to allow employee entry and is not designed or intended for continuous human occupancy.

“Contract Welder” means an employee of a contractor who has been contracted for the purpose of performing specific welding services on Company pipeline facilities.

“Defect” means an imperfection of sufficient magnitude to warrant weld rejection based on the stipulations in this standard.

“Imperfection” means a discontinuity or irregularity that is detectable by methods outlined in this standard.



## NGD Welding Manual

“Indication” means evidence obtained by nondestructive testing.

“Inspector” means a person designated to monitor the quality of work performed by a “welder” and for ensuring the “welder” is qualified according to the procedures established in this manual.

“In-Service pipeline welding” means welding on Company pipeline facilities that contain a gas or liquid such as natural gas, petroleum products or hydrostatic test water under static or flowing conditions.

“MSS” mean Manufacturers Standardization Society.

“Position welding” means welding in which the pipe or assembly is not rotating while the weld is being deposited.

“Procedure Qualification Record” (PQR) means a document that contains a record of how the weld was made and the destructive test results. The “PQR” may support one or more “WPS” documents.

“Qualified Welding Procedure” See Welding Procedure Specification.

“Repair” means any rework on a completed weld that requires welding to correct a defect.

“Roll welding” means welding in which the pipe or assembly is rotated while the weld metal is being deposited at or near top center.

“Root bead” means the first or stringer bead that initially joins two sections of pipe, a section of pipe to a fitting, or two fittings.

“Welder” means a person employed to specifically perform the function of welding on Company pipeline facilities.

“Welder Performance Qualification” means the process by which a welder is qualified to weld on Company pipeline facilities.

“Welding Procedure Specification” (WPS) means a welding procedure document that provides direction to the welder on joint design, type of electrode, welding parameters and the other conditions required to make the specific weld.

### 4. MATERIALS

[See Attachment 1 for fitting material steel grade and Specified Minimum Yield Strength.](#)

#### 4.1 Pipe and Fittings

All pipe and fittings shall conform to the following Specifications.

API Specification of Line Pipe 5L.

ASTM Specifications.

Company Material Specifications.

MSS Specifications for fittings.

All compressor station piping equal to or less than 2 inches NPS shall be at minimum extra



## NGD Welding Manual

strong wall.

Threaded pipe shall have sufficient remaining wall thickness after threading to meet design requirements.

Socket welds are limited to 2 inches for field welding and 6 inches for fabrication shops. Socket fittings are also allowed.

### 4.2 Pipe Wall Discontinuities

Repairs in the longitudinal seam are allowed, but must not be ground below the actual wall thickness of the pipe.

Hammering or repair patches shall not be used to repair imperfections.

#### 4.2.1 Pipe Ends

All material pressed inward and encroaching on the pipe bore shall be ground away to maintain the original contour of the pipe. The remaining wall thickness shall be equal to or greater than the minimum required for the pipe design. If grinding reduces the wall thickness below the minimum required wall thickness, the affected area shall be cut out and the end re-beveled.

Dents that affect the curvature of the pipe within 4 inches of the end of the joint shall be removed. The ends shall be re-beveled.

#### 4.2.2 Laminations

Pipe walls in a weld area must be inspected by an approved ultrasonic instrument and the portion of the pipe which contains the lamination be cut-out as a cylinder.

#### 4.2.3 Cracks

No welding shall be completed in a crack in the pipe. Cracks found in the pipe wall shall require that the portion of pipe containing the crack be cut-out as a cylinder.

#### 4.2.4 Dents

No welding shall be completed in a dent in the pipe.

#### 4.2.5 Gouges, Grooves, Scratches, and Notches

All gouges, grooves, scratches, and notches that do not encroach on the permissible wall thickness shall be eliminated by grinding, providing the wall thickness is not reduced to below the minimum requirements. Wall thickness tolerances from nominal are shown in Table 1. For gouges, grooves, scratches and notches that encroach on the permissible wall thickness, the defect shall be cut out or the whole joint rejected.



# NGD Welding Manual

Table 1 – Wall Thickness Tolerance for Steel Pipe  
 (Percentage of Nominal Wall Thickness not measured wall thickness)

| Size: NPS and Manufacturing Type              | API 5L Gr. B     | API 5L X42 and Up | ASTM (ASME) |
|---|------------------|-------------------|-------------|
| 2 ½ inches and smaller<br>Seamless and welded | +20.0%<br>-12.5% | +15.0%<br>-12.5%  | -12.5%      |
| 3 inches<br>Seamless and welded               | +18.0%<br>-12.5% | +15.0%<br>-12.5%  | -12.5%      |
| 4 inches – 18 inches<br>Seamless and welded   | +15.0%<br>-12.5% | +15.0%<br>-12.5%  | -12.5%      |
| 20 inches and larger<br>Seamless and welded   | +15.0%<br>-10.0% | +17.5%<br>-8.0%   | -12.5%      |

Using the data in Table 1, the maximum and minimum wall thicknesses can be calculated using one of the formulas below:

$$\text{Maximum wall thickness} = \text{Nominal wall thickness times } (1 + \frac{\text{the positive percentage}}{100})$$

$$\text{Minimum wall thickness} = \text{Nominal wall thickness times } (1 - \frac{\text{the negative percentage}}{100})$$

Example: For 4 inch pipe with a nominal wall thickness of 0.237 inch, the maximum wall thickness for welding is 0.237 times (1+0.15) which equals 0.273 inch. The minimum wall thickness for welding would be 0.237 times (1-.0.125) which is 0.207 inch.

## 4.3 Pipe Bevel Discontinuities

### 4.3.1 Arc Burns

Arc burns shall not be permitted on new pipe ends. These imperfections shall be cut out. The remaining pipe ends shall be properly re-beveled.

### 4.3.2 Laminations

Laminations or other visual defects in the pipe bevel that exceed 1/4 inch shall be removed by cutting out this portion of the pipe as a cylinder.

### 4.3.3 Bevel Damage

Bevel damage such as dents, gouges, or depressions shall be repaired if their depth exceeds one-sixteenth of an inch. Repairs shall be made by grinding or filing to smooth the defect into the existing bevel. Damage that requires grinding to the point



## NGD Welding Manual

where the bevel may be modified, from the tolerances on the welding procedure, shall be rejected and the end shall be re-beveled.

### 4.3.4 Root Face Damage

Hammering shall not be used to restore a damaged land.

The root face (land), if damaged, may be restored to its original dimension by filing or grinding. The gap from the ground area and the remaining land area shall not be more than 1/32 inches for ¾ inches long or 3/64 inches for 3/8 inches long. In the event restoration is not possible, the end shall be completely re-beveled.

If the imperfection is greater than 3/64 inches, the end shall be re-beveled.

### 4.3.5 Bevel Dents

Denting restricted to the top edge of the bevel shall be ground smooth and shall not be cause for rejection, unless, in the opinion of the welding inspector, the denting extends beyond the area where the cap pass will tie-in to the bevel edge.

## 4.4 Welded Closures

Welded closures shall be made with weld caps only. Flat plate steel shall not be used for permanent closures.

## 4.5 Flanges

Slip-on flanges shall not be used for working pressure over 720 PSIG. Slip-on flanges are not recommended for use over 4 inches NPS or in a cyclic stress environment.

Socket weld flanges shall not be used above 3 inches NPS. In compressor stations, socket weld flanges shall not be used above 2 inches NPS. Socket weld flanges shall be ANSI Class 600 or heavier.

Lap joint flanges shall not be used where vibration or lateral movement is anticipated.

## 4.6 O-let Fittings

The maximum size is 2 inches NPS. The maximum branch size is one size smaller than the nominal run pipe size. The run pipe wall thickness shall be at least standard wall or 0.250 inches whichever is less.

## 4.7 Reuse/Reclamation Practices for Weld Flanges and Fittings

### 4.7.1 General Requirements

Flanges and weld fittings, which have the minimum ¼ inch reclamation dimension, may be reclaimed for reuse, except for the following.

- Flanges or fittings which have been exposed to known sustained cyclic loading in previous service are not to be reused.
- Slip-on and lightweight (taper face) flanges and socket weld fittings are not to



## NGD Welding Manual

be reused.

- Fittings such as tees, elbows, reducers, caps, etc., on to which braces, taps or other connections have been welded are not to be reused.
- Flanges or fittings containing cracks of any depth or corrosion pits or gouges of a depth exceeding 10% of the system's or attaching pipe nominal wall thickness are not to be reused.

When fittings or flanges are reclaimed from service, they must be either:

- a. Cut from service with at least 1 inch of pipe remaining on the flange or fitting, returned to the machine shop, re-beveled back to the fitting, and returned to stock;
- b. Cut from service with sufficient pipe remaining to comply with the requirements for minimum distance between welds, re-beveled, and returned to stock. The remaining welds are to be nondestructively examined; or
- c. If circumstances dictate that a flange or fitting must be reused immediately in the field, it shall be re-beveled by either mechanical or flame cutting. In such circumstances, the length tolerance specified above is not mandatory, provided a satisfactory bevel can be obtained.

The reclaimed length of fittings other than ells shall be plus or minus  $\frac{1}{4}$  inch of the original fitting length. Otherwise the fitting shall be discarded.

Adding metal by welding to a fitting or flange to be reclaimed is prohibited.

If two fittings to be individually reclaimed are welded together, the assembly is to be separated by using a machining device.

Flanges and fittings are to be thoroughly cleaned and examined for discontinuities. If there is any question as to the soundness of a re-machined flange or fitting, it shall be examined by an approved nondestructive testing process.

All reclaimed flanges or fittings shall be appropriately identified. The suggested method is to write "reclaimed" on each fitting or flange, using a highly contrasting paint marker.

These requirements are not applicable to the reuse of caps and other fittings used solely for test purposes.

### 4.7.2 ANSI Weld Neck Flanges

Flanges shall have a machined, standard pipe weld bevel.

If the remaining straightaway dimension is less than  $\frac{1}{4}$  inch, the flange is to be discarded.

If necessary, the flange face may be machined to a limited degree, to clean and true up the face. The flange thickness shall not be reduced below the minimum specified.



## NGD Welding Manual

The hub taper shall not be altered in any manner.

### 4.7.3 MSS Flanges

The flange shall have a machined standard pipe weld bevel.

If the difference between the new overall length and the original overall length is 1/8 inch or greater, the flange is to be discarded.

If necessary, the flange face may be machined to a limited degree, to clean and true up the face. The flange thickness shall not be reduced below the minimum specified.

The hub taper shall not be altered in any manner.

### 4.7.4 Caps and Reducers

The fitting shall have machined, standard pipe weld bevels.

If the remaining skirt is less than ¼ inch, the cap or reducer shall be discarded.

### 4.7.5 ANSI Elbows

The fitting shall have machined standard pipe weld bevel.

The original center-to-face dimension shall not be reduced by more than 1/8 inch.

Elbows may be cut to smaller angle elbows. The angle is to be measured and marked on the fitting.

### 4.7.6 Tees

The fitting shall have machined, standard pipe weld bevels.

The original center-to-end dimensions shall not be reduced by more than 1/8 inch.

### 4.7.7 Other Butt-Weld Fittings

The fitting shall have machined, standard pipe weld bevel.

If the difference between the reclaimed length and the original overall length is greater than ¼ inch, the fitting shall be discarded.

## 4.8 Filler Metal

### 4.8.1 Type and Size

All filler metals shall conform to one of the following.

- a. AWS A5.1.
- b. AWS A5.2.
- c. AWS A5.5.
- d. AWS A5.17.



## NGD Welding Manual

- e. AWS A5.18.
- f. AWS A5.20.
- g. AWS A5.28.
- h. AWS A5.29.

### 4.8.2 Storage and Handling of Filler Metals and Fluxes

Electrode containers which have been opened shall be protected from direct exposure to moisture. All electrodes showing indications of deterioration, damage, or have been exposed to an adverse atmosphere or other detrimental conditions which may affect their operating characteristics or weld quality shall be discarded. Cellulose coated electrodes should not be stored in rod ovens. Open containers of low-hydrogen electrodes shall be stored in a rod oven maintained at 200-250 degrees F. Low-hydrogen electrodes shall be used within 8 hours after removal from rod oven. Unused low-hydrogen electrodes removed from rod oven shall be discarded.

Welding wire and submerged arc flux shall be packaged and stored according to manufacturer recommendations when not in use. Reclaiming fused flux is prohibited.

### 4.8.3 Filler Metal Groups

Filler metal groups and AWS specifications are shown in Table 2.

Table 2 – Filler Metal Groups

| Group | AWS Specification    | Electrode  | Flux   |
|-------|----------------------|--|--|
| 1     | A5.1 ,<br>A5.5       | E6010, E6011,<br>E7010, E7011                          |  |
| 2     | A5.5                 | E8010, E8011<br>E9010                                  |  |
| 3     | A5.1 OR A5.5<br>A5.5 | E7015,E7016,E7018<br>E8015,E8016,E8018,E9010           |  |
| 4     | A5.17                | EL8<br>EL8K<br>EL12<br>EM5K<br>EM12K<br>EM13K<br>EM15K | P6XZ<br>F6XO<br>F6X2<br>F7XZ<br>F7XO<br>F7X2 |
| 5     | A5.18                | ER70S-2,ER70S-6  |  |





## NGD Welding Manual

|   |       |                                      |  |
|---|-------|--------------------------------------|--|
|   | A5.28 | ER80S-D2,ER90S-G                     |  |
| 6 | A5.2  | RG60, RG65                           |  |
| 7 | A5.20 | E61T-GS, E71T-GS<br>(ROOT BEAD ONLY) |  |
| 8 | A5.29 | E71T8-K6                             |  |
| 9 | A5.29 | E91T8-G                              |  |

### 5. QUALIFICATION OF WELDING PROCEDURES FOR WELDS CONTAINING FILLER-METAL ADDITIVES

#### 5.1 Procedure Qualifications

Detailed procedures shall be established and qualified before any production welding is started. These procedures shall be adhered to except where a change is approved by Gas Standards.

#### 5.2 Welding Procedure Specification Testing

All welding procedures shall be tested and approved according to 49 CFR 192.225.

##### 5.2.1 Butt Welds Tests

- a. Tensile Test.
- b. Nick-break Test.
- c. Root-and Face-bend Test.
- d. Side-bend Test.

##### 5.2.2 Fillet Welds Test

- a. Break Test.

#### 5.3 Records

The details of each qualified procedure shall be recorded. The record shall show complete results of procedure qualification tests. The record shall be maintained as long as the procedure is in use.

#### 5.4 Process

The specific process or combination of processes used in the procedure shall be identified in the qualified welding procedure.

## NGD Welding Manual

### 5.5 Base Metal, Diameter and Wall Thickness Groups

Outside diameter and wall thickness groups have been established in accordance with API 1104. The outside diameter and wall thickness limitation over which welding procedures are applicable are established in each qualified welding procedure specification (WPS).

#### 5.5.1 Base Metal Groupings

Group 1 – Specified minimum yield strength less than or equal to 42,000 psi.

Group 2 – Specified minimum yield strength greater than 42,000 psi but less than 65,000 psi.

Group 3 – Specified minimum yield strength greater than or equal to 65,000 psi. Each grade shall have a separate qualification test.

#### 5.5.2 Diameter

Group 1 – Outside diameter less than 2.375 inches.

Group 2 -- Outside diameter from 2.375 inches through 12.75 inches.

Group 3 – Outside diameter greater than 12.75 inches.

#### 5.5.3 Wall Thickness

Group 1 – Wall thickness less than 0.188 inches.

Group 2 – Wall thickness from 0.188 inches through 0.750 inches.

Group 3 – Wall thickness greater than 0.750 inches.

### 5.6 Joint Design

Acceptable joint designs are specified in each qualified welding procedure and shown in Exhibit 1. For butt welds less than 0.875 inches wall thickness, the joint design in Exhibit 1, Figure 1 is preferred, however, a 37 ½ degree bevel maybe used, as shown in Figure 2. A bevel with no land is acceptable for oxyacetylene (OAW) welding.

For full encirclement-type, pad or saddle-type lap joints, the maximum dimension of L is 1.25t1 or t2, whichever is smaller; see Exhibit 1, Figure 7. The minimum dimension of L is ¼ inches. If the full encirclement-type lap joint thickness is greater than 1.25t1, it shall be tapered 1 on 4 (14 degrees) to a thickness of t1 at the weld.

For lap or tee fillet joints as shown in Exhibit 1, Figures 8 & 9, the maximum dimension of L is 1.25t1 or 1.25t2, whichever is smaller. The minimum dimension of L is ¼ inches.

For socket welds the minimum weld size is 5/32 inches or 1.25 times the nominal thickness of the pipe, whichever is larger. For socket weld flanges the minimum weld size is 1.4 times the nominal wall of the pipe.

Acceptable joint designs for butt welds having unequal wall thickness are shown in Exhibit 2.



## NGD Welding Manual

### 5.7 ESSENTIAL VARIABLES

A new welding procedure must be requalified when any essential variable is changed. Essential variables are listed in items a. through p. below. Changes that are not essential variables may be made without requalification providing the procedure specification is revised to show the changes prior to beginning production welding.

- a. A change in the process or combination of processes.
- b. A change from one base metal group to another.
- c. A change in joint design.
- d. A change in the welding position.
- e. A change from one wall thickness group to another.
- f. A change from filler material group to another.
- g. A change from DC electrode positive to DC electrode negative or vise-versa.
- h. A change in current from DC to AC.
- i. An increase in the maximum time between root bead completion and start of second bead.
- j. A change in the direction of welding.
- k. A change in the shield gas or range of shielding gas flow rate.
- l. A change in shielding flux resulting in a different AWS Classification Number.
- m. A change in the speed of travel.
- n. A decrease in the specified minimum pre-heat temperature.
- o. A change in the range of values in post-weld heat treatment.
- p. The addition of post-weld heat treatment.

### 6. QUALIFICATION OF WELDERS

#### 6.1 Initial Qualifications

During the qualification testing, the welder shall use the same welding technique and proceed with the same speed the welder will use to do production welding.

Location of the testing and the testing instructor is at the discretion of the Company.

The welder shall be fully supervised and controlled by the welding instructor

A welder shall be allowed to weld on Company property only with the hand by which qualified. Both hands may be qualified during testing.

Qualification welds shall be prepared and made with the established and approved WPS.

An identification number or symbol shall be assigned to each Company welder and it shall appear on both the welding permit and test reports.



## NGD Welding Manual

### 6.2 Testing of Qualification Welds

#### 6.2.1 Visual

The welding instructor may at any time terminate the test if the welder does not exhibit the necessary skills. The welded test coupon shall satisfy the visual requirement in Exhibit 3.

#### 6.2.2 Destructive Testing

All initial qualification welds shall be evaluated by destructive testing. The test specimens shall be removed from the completed weld and tested in the presence of the welding instructor. The tests are as follows.

- a. Butt weld tensile strength test.
- b. Butt weld nick-break test.
- c. Butt weld bend test.
- d. Fillet weld break test.

### 6.3 Required Welder Qualifying Tests for Shield Metal Arc Welding (SMAW) and Gas Metal Arc Welding (GMAW)

#### 6.3.1 Pipeline Welder Test

A welder who wishes to weld on pipeline, compressor stations or M&R stations shall successfully complete the following tests.

- a. One 12 inch butt weld in the 45 degree fixed position with wall thickness greater than or equal to 0.250 inches.
- b. Lay out, fit, cut and weld a 12 inch x 12 inch bottom branch connection with wall thicknesses greater than or equal to 0.250 inches. A full size hole shall be cut out of the run pipe.

A welder who successfully completes both tests shall be qualified to weld in all positions, on all wall thicknesses, on all pipe diameters, on all joint designs and fittings.

#### 6.3.2 In-service Welder Test

To qualify for in-service welding a welder must successfully complete the following two tests. Both tests are performed on a cylinder with flowing water to simulate in-service conditions. The increase of water temperature from the inlet to the outlet shall be minimized and can be checked by hand. For SMAW, low-hydrogen electrodes shall be used.

Weld a 12 inch full-encirclement sleeve to a grade X-42 cylinder in the 45° position as shown in Exhibit 6. The 12 inch run pipe shall be 0.250 inch. The sleeve shall be placed on the pipe so that the longitudinal seams are positioned on the side of the pipe. The sleeve's two longitudinal butt welds shall be welded first, followed by the two circumferential fillets welds.



## NGD Welding Manual

Lay out, fit, cut and weld a 12 inch by 12 inch branch connection in the horizontal position. The wall thickness shall be 0.250 inch for 12 inch run pipe. This connection shall be made using uphill direction of welding.

The welds shall pass visual inspection, dye penetrate inspection or magnetic particle according to Exhibit 3, page 2, "Standards of Weld Acceptability."

A welder who successfully completes the above tests shall be qualified to weld on in-service pipelines using low-hydrogen electrodes only on all pipe diameters within the essential variables listed below.

- a. Welding process.
- b. Direction of welding.
- c. Wall thickness group.
- d. Welding position.
- e. Joint Design.

After passing the test requirement of Section 6.3.3, a welder who is qualified as a Pipeline Welder is qualified for in-service welding on all diameters, all positions and all wall thicknesses.

### 6.4 Required Welder Qualifying Tests for Oxyacetylene Welding (OAW)

A welder who wishes to weld on pipeline facilities using the oxyacetylene welding process must pass the following welding tests.

- a. Two 1 ¼ inch Butt welds on wall thickness of 0.191 inch on grade B pipe in the 45 degree horizontal fixed position.
- b. One 6 inch Butt weld on wall thickness of 0.156 inch on grade X42 pipe in the 45 degree horizontal fixed position.

### 6.5 Required Welder Qualification Test for Submerged Arc Welding (SAW)

A welder must complete a butt weld using the heaviest wall thickness the welder will weld on during production. To qualify for all pipe diameters separate tests must be made for pipe diameters less than 12.75 inches and one for pipe diameters equal to or greater than 12.75 inches. A welder may choose to qualify for only one diameter range either equal to and greater than 12.75 inches or less than 12.75 inches. The range or ranges will be noted on the welder's permit card.

### 6.6 Structural Welder Qualifications

A person who wishes to be a structural welder must pass the following test.

- a. The welder shall make a fillet weld test in both the overhead (4F) and vertical (3F) positions.

To be acceptable, the completed welds shall be successfully tested per the appropriate requirements.

Structural welders may be required to take these tests prior to each job, but will not be issued



## NGD Welding Manual

a "Temporary Welding Permit." The welding instructor may waive the tests if they are familiar with the quality of the welder's work.

### 6.6.1 Structural Weld Tests

#### 1. Visual

To pass the visual examination, the fillet weld shall present a reasonably uniform appearance and shall be free of overlap, cracks, and excessive undercut. There shall be no porosity visible on the surface of the weld.

#### 2. Macroetch

For acceptable qualification, the test specimen, when inspected visually, shall conform to the following requirements.

- a. Fillet welds shall have fusion to the root of the joint, but not necessarily beyond.
- b. Minimum leg size shall meet the specified fillet weld size.

#### 3. Destructive Weld Test

The specimen shall pass the test if it bends flat upon itself. If the fillet weld fractures, the fractured surface shall show complete fusion to the root of the joint and shall exhibit no inclusion or porosity larger than 3/32 inch in greatest dimension. The sum of the greatest dimension of all inclusions and porosity shall not exceed 3/8 inch in the 6 inch long specimen.

### 6.7 Welding Permits

A welding permit, valid for a maximum of 2 years for company welders and 1 year for contract welders, will be issued upon successful completion of the initial testing on each process (Exhibit 4). The permit shall indicate the date tested, the welding instructor, the qualified processes, the qualified hand, the qualified position, the qualified diameter range, the qualified wall thickness range and the maximum pipe grade.

During welding permit qualification, the welder's welding machine shall be checked with independent voltage and amp meters to insure proper operation within the welding procedures specifications. If the welding machine is found to be operating outside the indicated ranges in the welding procedure, the unit shall be recalibrated.

The appropriate welding instructor shall maintain a record of qualified welders and permits. Each Company shall establish their own requalification testing intervals. The welder shall schedule with the welding instructor for requalification tests.

Structural welding permits have no time limit and are valid as long as the welder has made a production weld within the last 6 months.

### 6.8 Six-month Requalification Requirements

No welder may weld with a particular welding process unless within the preceding six calendar months the welder has welded with that process and has at least one weld acceptable by either destructive or approved nondestructive testing. The welder is responsible to complete the six-month requalification.



## NGD Welding Manual

If a production weld is used for the six-month requalification requirement, the welder shall obtain a copy of the NDT report signed by the welding inspector and showing the disposition of the weld. The report shall be forwarded to the appropriate welding instructor for review and qualification update.

A company welder not meeting the six-month requalification requirement shall be notified along with his supervisor by the welding instructor. The welder shall not perform any production welding until a retest is completed.

Destructive tests are listed in Section 6.2.2 of this standard. Non-destructive tests include the following.

- a. Radiographic (X-RAY).
- b. Ultrasonic Examination.
- c. Dye Penetrate Examination.
- d. Magnetic Particle Examination.

### 6.9 RECORDS

#### 6.9.1 Company Forms/Database

The welding instructor shall maintain a database containing each welder and the process in which they are or were qualified.

#### 6.9.2 Records Retention

Welder qualification records shall be retained for 5 years.

## 7. PRODUCTION WELDING

All welding shall be performed by qualified welders using qualified procedures. The surfaces to be welded shall be smooth, uniform and free from laminations, tears, scale, slag, grease, paint and other material that might affect the quality of the weld. Longitudinal seams in adjacent lengths of longitudinal welded pipe shall be offset by a minimum of 2 inches.

When welding dual marked or stamped pipe always weld to the highest grade marked or stamped on the pipe using the appropriate WPS for the highest grade.

When welding pipe or fittings of different grades always use a WPS qualified for the highest grade.

Welding equipment used for field welding shall be maintained in good working condition and have the same performance capabilities as that which was used to qualify the welding procedure. Any machine that is not performing satisfactorily shall be removed from service and repaired or replaced. Electrode holder shall be fully insulated and shall not be cooled by water immersion. Water cooled holders shall not be used if any water leaks or condensation exists.

A welder who makes a weld that fails to comply with the requirements of this section will be disqualified from further welding.

The starting point of two successive passes for SMAW welding shall not begin at the same point on



## NGD Welding Manual

the circumference of the pipe.

Oxyacetylene welding is restricted to Grade B pipe with nominal diameters less than or equal to 6 inches. The designed stress level of the piping system shall be 20% or less.

### 7.1 Depolarization

See Exhibit 7 for methods to depolarize or demagnetize pipe for welding.

### 7.2 Alignment

Miter welds are not allowed. Deflections caused by misalignment up to 3 degrees are not considered miters.

#### 7.2.1 Butt Welds

Joint alignment shall have a uniform spacing (root opening) throughout the circumference of the joint. The spacing shall be in accordance with the approved welding procedure.

Butt welds shall be aligned to minimize the offset (high-low) between the pipe and or fitting surfaces. Offset caused by dimensional variations (out-of-roundness) shall be equally distributed around the circumference of the pipe and may be reduced to a minimum by rotation of the pieces to obtain the best fit.

Limited high-low is acceptable provided the root of adjacent pipe and/or fitting joints is completely tied-in by weld metal. For single side welding, the maximum allowable internal offset shall not exceed 3/32 inches for wall thicknesses greater than 0.250 inches and 3/64 inches for wall thickness less than or equal to 0.250 inches. For offsets exceeding these tolerances see Exhibit 2 for acceptable designs for unequal wall thicknesses.

The alignment of the abutting pipe or fitting ends shall be such that the abutting edges (land) have a uniform spacing (root gap) around the circumference of the joint. This spacing shall be in accordance with the WPS.

The alignment shall be preserved until the root bead is completed.

When using backing rings, the lands on the pipe bevels shall be fitted tightly against the raised portion of the backing rings.

#### 7.2.2 Line-up Clamps

Either internal or external line-up clamps should be used for assuring proper alignment for butt welds unless it is impractical due to dimensional differences such as flange or fitting to pipe, etc. The clamps shall remove out-of-roundness and shall provide a uniform joint fit-up. High-low conditions shall not exceed 3/32 of an inch.

External line-up clamps may be removed after the root bead is fifty (50) percent complete, provided the completed portion of the root bead is in segments of approximately equal length, and provided the segments are equally spaced around the circumference of the pipe. If conditions are such that it is difficult to prevent movement of the pipe, or if the weld is excessively stressed, the root bead shall be completed to





## NGD Welding Manual

the extent possible before the line-up clamp is released.

When an internal alignment clamp is used for achieving alignment, it shall be held firmly in position until the root pass is one hundred percent complete and the pipe has been properly supported.

### 7.2.3 Tack Welds

If tack welding is used for joint lineup, the tack welds shall be considered part of the root bead and shall be made with the same class filler metal and approved welding procedure including preheat requirements as the final root bead. The area to be tacked shall be free of moisture. Tack welds should be uniformly placed around the pipe circumference be of sufficient number and length to maintain the root opening and alignment.

Tacks of excessive thickness and all tack weld crowns shall be ground and the stop and start points feathered with a disc grinder prior to application of the final root bead to ensure complete root bead continuity. All tacks made with the Gas Metal Arc process shall be reduced to a feather edge. The use of an oxy-acetylene cutting torch or a welding electrode will not be permitted for removing excess metal.

Tack welds shall be thoroughly cleaned of slag and scale and examined visually for discontinuities. If cracked or found to be defective, they shall be removed.

### 7.2.4 Socket Welds

A 1/16 inch gap must be left between the pipe end and socket fitting before welding. The use of a contraction ring (Gap-A-Let™) is recommended. If a Gap-A-Let™ is not available use the following procedure to properly gap the socket joint.

- a. The pipe ends must be free of burs and lip edges.
- b. Insert the pipe into the socket fitting until it bottoms.
- c. Mark the pipe and fitting at a predetermined distance from the fitting face. The scribe marks should be placed far enough (i.e., approximately 1 inch) from the weld so they will be visible after welding for inspection purposes.
- d. Withdraw the pipe 1/16 inches and tack weld.

### 7.2.5 Slip-on Flanges

Slip-on flanges shall be positioned for welding so that the distance from the face of the flange to the pipe end shall be equal to the nominal pipe wall thickness, plus approximately 1/8 inch. The welds shall be made in a manner that will not require re-facing of the flange.

## 7.3 Bevels

All traces of corrosion preventive coating shall be removed from the welding area. The minimum cut back for coal tar and extruded coating shall be 6 inches; for Fusion-Bonded Epoxy (FBE), 1-1/2 inches. Internal coating shall be removed back a minimum ¼ inches.



## NGD Welding Manual

All rust, scale, primer, oil/grease, paint, and other material that may be detrimental to the finished weld shall be removed from the bevel and shall also be removed 1 inch back from the internal pipe surfaces. Power brushes shall be used to clean all beveled surfaces. Power-sanding discs, sand blasting and/or safety solvents may be used if power brushing does not clean the bevel satisfactorily.

Water or moisture shall be completely removed by preheating the pipe with a propane or oxy-acetylene torch using a "rosebud" tip.

FBE coating shall be protected using fireproof blankets or suitable protective material on the top 1/3 of the pipe diameter for 2 feet on each side of the weld joint.

### 7.3.1 Mill Bevels

All mill bevels shall conform to the joint design used in the welding procedure specification.

### 7.3.2 Field Bevel

Pipe may be field beveled by machine tool, machine oxygen cutting or manual oxygen cutting. The beveled ends shall be reasonably smooth and uniform. The dimensions shall conform to the welding procedure specification.

## 7.4 Weather Conditions

Welding shall not be done when weather conditions impair the quality of the finished weld. Shelters or weather screens which protect the welding area may be used to shield or protect the finished weld from inclement weather. The shelter or screen shall provide adequate room to conduct proper welding. If conditions necessitate the removal of the shelter or weather screen before weld has cooled, a temporary covering of felt tar paper or similar covering shall be placed around the welded joint for protection. At no time may liquids be used to cool a welded joint.

If weather interrupts the welding process of unfinished welds, the joint shall be protected by felt tar paper or similar covering until a shelter or weather screen can be installed. Once the welding area is protected, the weld shall be preheated to at least 250 degrees F to eliminate any moisture on the weld area before welding resumes. Refer to welding procedure specification for any additional preheating requirements.

## 7.5 Cleaning and Grinding

Power grinding or brushes shall be used to remove slag, spatter, oxides, flux and scale from grooves and each bead prior to welding the next pass. All cover passes shall be brushed and cleaned to prepare the weld for inspection.

Peening may be used for slag removal only. Pneumatic needle scalers and hand chipping hammers may be used.

Power grinders shall be used to feather stops and starts from tacks welds and to remove high points in the root bead. The crown of the root bead shall be ground down and power brushed before applying the hot pass.



## NGD Welding Manual

### 7.6 Filler and Finish Beads

The number of filler and finish beads shall be such that the completed weld has a substantially uniform cross section around the entire weld. The crown surface of the weld shall not fall below the outside surface of the pipe. The face of the completed weld should be 1/8 inch wider than the original groove.

### 7.7 Identification of Welders

Each welder shall mark the weld or section of a weld for which he has been responsible with the identification assigned to him by the welding inspector using a weatherproof crayon or a permanent ink marker.

### 7.8 Minimum Number of Welders

One welder is recommended for all passes for pipe sizes 14 inches O.D. and smaller. Only one welder shall weld on pipe 4 inches NPS or less. Two welders are required when using the SMAW process on 16 inches O.D. pipe and larger for the root pass and second pass (hot pass), operating simultaneously on opposite sides. Only the Company's authorized representative can approve using one welder for pipe 16 inches OD or larger. One welder may complete the remaining passes of the weld if they are completed within the time restraints of the applicable welding procedure specification.

### 7.9 Minimum Distance between Welds

The recommended minimum distance between welds is.

- a. 2 inches between adjacent fillet welds. If the operating pressure produces a hoop stress less than 20% SMYS, the minimum distance is 1 inch.
- b. 2 inches between a fillet and a butt weld. If the operating pressure produces a hoop stress less than 20% SMYS, the minimum distance is 1 inch.
- c. 12 inches or one pipe diameter, whichever is smaller, for parallel butt welds. For shop fabrication or completely unrestrained conditions, 4 inches or one pipe diameter whichever is smaller, for parallel butt welds.

Forged or fabricated steel elbows and elbow segments must have a minimum arc length measured along the crotch of at least 1 inch.

Only the Company's authorized representative can approve any deviations in the recommended minimum distances between welds.

Manufacturer recommendation for minimum distance from pressure control fittings shall be followed.

The following stress relieving procedure shall be performed if the above conditions are not met.

1. The temperature shall not be less than 1100 degrees F.
2. The temperature of the heating facilities shall not exceed 800 degrees F at the start of the stress relieving cycle. The maximum heating rate shall be 400



## NGD Welding Manual

degrees F per hour.

3. The stress relieving temperature shall be maintained for a minimum of one hour.
4. The cooling rate above 800 degrees F shall be less than or equal to 500 degree F per hour. Below 800 degrees F, the weld may be cooled in still air.
5. The temperature and rates of heating and cooling shall apply to a width on each side of the weld equal to 4 times the pipe wall thickness.
6. A record of the stress relieving procedure including time and temperature sequences shall be kept. The record shall be signed by the welding inspector or the Company authorized representative. The record shall be maintained in the construction records for the life of the facility.

### 7.10 Transition Joints

The transition between pipe ends of unequal thickness shall be by mechanical tapering, or by welding to provide a taper of 30 degrees max. - 14 degrees min. (1:4). A prefabricated transition nipple not less than one pipe diameter or 12 inches in length whichever is smaller can be used for the transition for field welding. The transition nipple for shop fabrication shall be 4 inches long or one pipe diameter whichever is smaller. When a transition taper is required, it shall be made using a mechanical end preparation machine.

### 7.11 Weld Joint Clearance

The working clearance around the pipe for welding should allow the welder sufficient physical and visual access. When the pipe is welded in a ditch, the bell hole shall be of sufficient size to provide the welder(s) ready access to the joint and shall provide sufficient clearance to enable the welder(s) to exercise normal welding skill. The clearance shall be a minimum of 16 inches when welding above ground.

### 7.12 Preheating of Welds

Pipe shall be preheated and the temperature monitored in accordance with the welding procedure specification. Preheating may be performed by propane or oxy-acetylene torches with a "rosebud" tip. Preheating shall always be done when the pipe is wet or damp for purposes of drying the pipe prior to welding.

The preheat temperature shall be confirmed using temperature indicating crayons or direct reading pyrometers. Measurements shall be made at four locations ninety degrees apart on each side of the weld joint. The location shall be 2 inches from the weld joint centerline. Maximum temperature differential between any two points shall not exceed 50 degrees Fahrenheit.

Half the wall thickness of the welding groove or a minimum of two complete weld passes whichever is greater shall be made prior to leaving the weld in the unfinished condition. Depending on the pipe wall thickness and/or weld stress level, the welding inspector may require additional passes be made prior to leaving the weld in a temporarily unfinished condition or may require the weld be completed. The weld joint shall be preheated before welding resumes according to the welding procedure specification. All tie-in welds shall be completed without interruption.

Preheating the inside wall to 250 degrees F minimum and 350 degrees F maximum shall be



## NGD Welding Manual

completed before all back welding has commenced.

All repair areas shall be preheated to 250 degrees F minimum and 350 degrees F maximum in the area of the repair and 2 inches from the edge of the repair in all directions.

### 8. INSPECTION OF WELDS

Unless specified otherwise, the standard of acceptability for the radiographic film interpretation and ultrasonic testing of all regulated pipeline or piping system welds shall be acceptable standards set forth in API 1104. The current acceptance standards are located in Exhibit 3. The welding inspector may reject a weld meeting the acceptance standard if in the inspector's opinion a defect exists that is detrimental to the weld.

All welds shall be visually inspected to insure that the welding is performed in accordance with the approved welding procedure specification and the welding meets the requirements of this standard. Additional non-destructive testing may be required per GS 1210.010 and GS 1210.010 (MA), "Nondestructive Testing".

At the discretion of the Company production welds may be cut out and tested to confirm the adequacy of the welds. Welds meeting the current requirements of API 1104 will be charged to the Company. Those welds not meeting the current requirements of API 1104 will be charged to the pipeline contractor.

The acceptance standards for visual inspection and non-destructive testing are located in Exhibit 3.

For each project a Company representative shall determine all welder qualifications and review the status of the welder permits.

#### 8.1 Visual Inspection of Welds

Visual inspection of welding shall be performed by personnel who are trained in the following area.

- a. Visual inspection.
- b. Welding and cutting safety.
- c. Welding Procedure Specifications.
- d. Weather consideration for welding.

The same personnel shall also have welding or pipeline construction experience and shall pass the Operator Qualification exam. The welder may be the person performing the visual inspection of welding.

#### 8.2 Non-Destructive Testing Personnel

All non-destructive testing personnel shall be certified to level I, II, or III with the recommended of American Society of Nondestructive Testing. Only level II or III certified non-destructive personnel shall interpret test results. Copies of the certification shall be retained by the Company in the appropriate file for the completed welds.

#### 8.3 Records

The radiographic contractor shall be responsible for furnishing the field representative and



## NGD Welding Manual

construction contractor's representative with a detailed report of each of the previous day's radiography. If no radiographs were made, but were scheduled to be performed, a report shall be made by the radiographic contractor explaining the reason for the absence of the radiographic report. The daily radiographic report supplied shall include, but is not limited to the following.

- a. Weld ID Number.
- b. Status of Weld (in code/out of code).
- c. Defect Type.
- d. Location of Defect on Pipe Circumference.
- e. Location of Defect in Reference to cross-section (based on judgment).
- f. Date of Radiography.
- g. Pipe Diameter/Wall Thickness.
- h. Weld Location – GPS Coordinates preferred.
- i. Number of Welds Radiographed.
- j. Crew Size and Unit No.
- k. Radiographer's Signature and CWI level.
- l. Defect Code.
- m. Company's Representative's Signature.

The radiographic contractor shall keep a copy of all daily reports for the duration of their assignment to the project.

### 9. WELD REPAIR

Welds found to be defective shall be repaired or cut-out. Repairs shall use the approved repair welding procedure specification or the original welding procedure specification.

All discontinuities observed by the welder or welding inspector shall be removed or repaired prior to NDT using the original WPS. This procedure is not considered a repair operation.

All discontinuities shall be ground down to sound metal. The weld area shall be wire brushed and free of slag and scale.

All repair areas shall be preheated to 250 degrees F minimum and 350 degrees F maximum for 3 inches in each direction of the repair area prior to welding.

The Company's authorized representative may for any reason condemn the weld and require the weld be cut out as a cylinder and the pipe ends be re-beveled.

Only one repair attempt is allowed without approval **from the welding inspector** per each repair area. The weld shall be cut out and the pipe ends re-beveled if this approval is not granted.

Radiographic inspection shall include the repaired weld area and for 4 inches on each side of the repaired area. The Company may require the entire weld to be re-tested.



## NGD Welding Manual

### 9.1 Cracks

All cracks not meeting the acceptance standard in Exhibit 3 Page 2 shall be removed except in unusual situations and no other alternative exists. The crack must be less than 8% in weld length to be considered for repair.

### 9.2 Arc Burns

All arc burns shall be cut out as a cylinder except in unusual conditions and no alternative exists.

If the arc burn is to be repaired, the area shall be ground down to sound metal and have a smooth contour. The wall thickness in the ground area shall be checked. If the remaining wall thickness is less than the required wall thickness, the damaged area shall be removed from the pipeline as a cylinder.

For X65 or greater grade pipe, the area shall be etched with Ammonium Persulfate used in 10% by weight solution. If the area etched by the solution darkens, then the area shall be ground down again and etched until the darkening ceases.

## 10. SAFETY

All Company safety practices and policies shall be followed during all welding and cutting operations including destructive and non-destructive testing. Refer to HSE 4120.010 "[Welding and Cutting Safety](#)" for additional requirements.

### 10.1 General Area

Warning signs shall be posted designating permanent welding areas and indicating proper personal protection equipment shall be worn.

There shall be no leaks of cooling water, shielding gas, or engine fuel that could affect the safety of the welding area.

In confined spaces, the welding power source and any gas cylinders shall be located outside the confined space and clear of the exit area. Any wheel equipment shall be blocked securely to prevent movement before any operations begin in a confined space. All confined space operations shall follow the Company's confined space work permit requirements. Refer to [HSE 4100.010 "Hazardous Atmosphere Considerations"](#) for additional requirements.

### 10.2 Eye and Face Protection

Helmets and hand shields shall be made from material that is thermally and electrically insulating, noncombustible or self-extinguishing and opaque to visible, ultraviolet and infrared radiation. The material shall be able to be disinfected. Helmets and hand shields shall protect the face, forehead, neck and ears to a vertical line in back of the ear from direct radiant energy from the arc and from weld splatter. A window shall be provided for filter plates and cover plates shall be designed for easy removal and replacement of filter plates. All helmets and hand shields shall not readily irritate or discolor the skin.

Lift front helmets shall have a fixed high impact resistant safety lens or plate on the inside of the frame to protect the welder when the front is lifted.





## NGD Welding Manual

All high impact lenses and plates shall be marked with the letter “H”. Exhibit 5 indicates the shade number required for certain welding operations.

All goggles shall be vented. Cup type goggles shall have baffles to prevent light from entering the eye cup.

Helmets or hand shields with filter lenses and cover plates shall be used by operators and nearby personnel when view welding. Safety goggles, glasses or other suitable eye protection shall be worn during arc welding or cutting. Safety glassed or goggles with side shields shall also be worn during grinding, brushing or other activities resulting in flying particles.

Safety glass with filter lenses without side shields may be worn during light work, torch blazing, or for inspection. All helpers shall wear similar eye protection.

For large viewing areas such as training or demonstrations, a large filter window or curtain may be used rather than individual eye protection. Suitable arrangements shall be used to prevent direct viewing of the welding or cutting arc and to protect viewers from sparks and flying objects.

Helmets, hand shields and goggles shall be well maintained. They shall not be transferred from one employee to another without being cleaned and disinfected.

Refer to [HSE 4200.030 “Eye and Face Protection”](#) for additional requirements

### 10.3 Protective Clothing

Clothing made from synthetic or plastic material is not allowed near welding or cutting areas.

Noise protection shall be used in areas where the noise level exceeds Company allowable limits.

### 10.4 Ventilation

Welders and helpers shall be positioned to avoid direct breathing of the fume plume. When forced air is used for ventilation it shall be directly across the face of the welder and not behind the welder. Precautions shall be deployed to prevent the contaminants from entering other work areas.

Mechanic ventilation shall be used indoors when the following conditions exist.

- a. Cutting of stainless steel.

Local mechanic ventilation and respiratory protection shall be used when using consumables containing the following chemicals.

|           |          |          |
|-----------|----------|----------|
| Antimony  | Chromium | Mercury  |
| Arsenic   | Cobalt   | Nickel   |
| Barium    | Copper   | Selenium |
| Beryllium | Lead     | Silver   |





## NGD Welding Manual

Manganese

Vanadium

The Material Safety Data Sheets (MSDS) of the consumable shall be checked to determine if any of the above chemicals are present. All persons in the immediate vicinity of the welding or cutting shall also be similarly protected.

Local mechanical ventilation or respiratory protection shall be used when welding or cutting operations involve fluxes, coating or other material containing fluorine or zinc compounds.

Manufacturer instruction shall be followed when using any cleaning agents in the welding area. Chlorinated hydrocarbons cleaning agent shall be kept out of the welding or cutting areas and out of atmosphere penetrated by ultraviolet radiation.

Only specifically trained personnel are allowed to weld or cut in area involving asbestos covered surfaces. Local health regulations shall be consulted before any welding or cutting takes place in asbestos areas.

Contact supervision or the HSE department for any questions regarding ventilation or air quality.

### 10.5 Fire Prevention and Protection

Provisions shall be made to protect against electrical shock when floors are wetted or covered.

A fire watcher shall be used when combustibles are within 35 feet of the welding or cutting operation. The fire watch will remain in effect until 30 minutes after welding or cutting operations cease.

All welding or cutting areas not designed for welding or cutting shall be inspected to insure proper safety precautions are met.

Oxygen shall not be substituted for any other gas. Oxygen shall not be used to dust off clothing or work areas, blow out pipelines or fittings or strike oily surfaces, greasy clothing, fuel lines or storage tanks. Oxygen handling equipment shall be kept clean and not handled by oily hands or gloves.

Arc welding and oxy-fuel cutting can be performed on gas-filled pipelines if there is a positive pressure at the point of welding or cutting at all times. All atmospheric openings shall be closed or sealed. If positive pressure cannot be maintained, then the pipeline shall be purged with air or inert gas before welding and cutting begins.

The atmosphere shall be tested with a combustible gas detector in work areas where gas may be present. Testing shall continue periodically during the work.

### 10.6 Welding Equipment

#### 10.6.1 Oxy-fuel Welding and Cutting Equipment

Cutting torches, hoses and hose connections shall be leak checked after assembly and before lighting the torch. Hoses showing leaks, burns, worn places or other defects shall be repaired or replaced. Each day the hoses shall be purged before first use. Do not use matches or cigarette lighters to light a torch. Use a friction lighter,



## NGD Welding Manual

stationary pilot flame or other suitable source of ignition. Follow manufacturers' procedures with respect to the sequence of operations in lighting, adjusting and extinguishing torch flames. When hoses are taped together, not more than 4 inches out each 12 inches long hose shall be covered in tape. Welding gas hose connections shall not be compatible with breathing air hose connections. All hoses connections shall be fabricated to withstand twice the pressure the hose connections are normally subjected to in service but at least to 300 psig. Oil free air or inert gas shall be used for testing.

Pressure regulators shall only be used for the gases and pressures for which they are labeled. Union nuts and connections on cylinders shall be inspected before use. All damaged nuts or connections shall be replaced. Oxygen gauges shall be marked "USE NO OIL". All regulators shall be drained of oxygen before connection to a cylinder or manifold by opening and closing the outlet valve with the regulator adjustment screw engaged before the inlet valve is opened. All cylinder valves shall be opened slowly. Regulators shall be repaired by properly trained mechanics.

### 10.6.2 Welding Machine and Associated Equipment

All portable control devices shall be grounded through a conductor in the control cable for devices operating at 50 or more volts.

Coiled cables on the storage spool are allowed.

The welding machine shall be turned off when the welder leaves the area for any appreciable time.

Semi-automatic welding machine guns shall be placed so the switch cannot be accidentally operated when not in use.

### 10.7 Power Tools

All portable grinders and power wire brushes shall be equipped with safety guards. The guard shall be between the operator and the wheel during use. The maximum angular exposure of the grinding wheel edge is 180 degrees. The guard shall be installed to deflect pieces of broken wheel or wires away from the operator.

Refer to HSE 4100.050 "Tools and Equipment - Plant Operations" for additional requirements

### 10.8 Gas Cylinders

Only the owner or persons authorized by the owner may fill a cylinder. . Cylinders without markings shall not be used and shall be returned to the supplier. Only the owner shall change the markings on a cylinder. All cylinders shall be equipped with proper connections. Every cylinder with a water-weight capacity of 30 lbs shall have a means to connect a valve protection cap or collar or recess to protect the valve. The temperature of the contents of the cylinder shall never exceed 130 degree F. An attempt should be made to extinguish small fires at a cylinder leak with available firefighting equipment. The local fire department shall be called if the fire cannot be extinguished.

Larger fires shall be allowed to burn out. Company personnel shall be kept as far away from the cylinder as possible. The local fire department shall be called.



## NGD Welding Manual

Acetylene shall not be used at pressures over 15 psig.

The cylinder connections shall be wiped with a clean cloth before connecting a regulator to a cylinder. Never stand in front of the valve when opening the valve without a regulator. Cylinder valves shall be closed and gas released from the regulator before the regulator can be removed from the cylinder.

A high pressure cylinder shall be fully open and back seated when in use. Cylinder valves shall be closed when welding or cutting is completed.

Nothing may be placed on top of a cylinder when in use. [A suitable cylinder truck, chain or steadying device shall be used to keep the cylinder steady while in use.](#) Cylinder shall be placed far enough away from the welding or cutting to protect the cylinder from sparks, hot slag or flame. Otherwise fire-resistance screens shall be used. Cylinder shall also be placed out of the electrical circuit and away from radiators, piping systems, layout tables and other areas that may be used for grounding welding equipment. Arcs shall not be struck on cylinders.

Open flames or boiling water (212 degrees F or higher) shall not be used to thaw out frozen acetylene cylinder valves. Hot water less than 212 degrees F may be used.

### 11. IN-SERVICE WELDING

For safety of employees and quality of welds, pipeline pressures [should](#) be reduced to pressures which produce hoop stresses less than 30% of SMYS. Higher stress pipelines tend to also flow more gas past the in-service weld causing greater cooling rates. Cooling rates have an impact on the weld quality.

Only welders qualified for in-service welding may weld on mains operating at pressures in excess of 60 psig.

#### 11.1 Design Limitations

##### 11.1.1 Location and Position

Branch connections shall be located 12 inches or one pipe diameter from any girth weld or pipe bend. All branch welds shall be made at 90 degrees to the header pipe. Hot tapping in the longitudinal seam of the header pipe is not recommended. If necessary, the seam shall be ultrasonically tested. The seam shall meet the minimum wall thickness of the surrounding pipe wall.

##### 11.1.2 Design Pressure

All manufactured fittings, including repair fittings, shall have design rating equal to or greater than the MAOP of the pipeline. All weld-o-let fittings shall be extra strong and shall only be used on wall thicknesses 0.188 inches and greater. All thread-O-lets and socket-o-let fittings shall be 3000 lbs or greater.

##### 11.1.3 Branch Reinforcement Members

See GS 2420.010 "Reinforcement Requirements for Steel Pipe Branch Connections" for guidance on when and what type of reinforcement is to be used for branch connections.

## NGD Welding Manual

All branch reinforcement members' wall thickness shall be the thicker of extra strong wall (schedule 80) or the minimum required wall to meet the MAOP of the pipeline. The thickness of local reinforcement members such as pads or saddles at the fillet weld shall not be more than 1.25 times the thickness of the run pipe.

The length of the reinforcement member measured along the axis of the header pipe shall be twice the inside diameter of the branch pipe.

### 11.2 Preliminary Steps

Before the in-service welding begins these steps shall be followed.

- a. Remove the coating and clean the weld area.
- b. The header pipe shall be inspected for laminations, corrosion pitting, dents, grooves or other defects. At least 4 ultrasonic wall thickness measurements shall be taken along the intended weld area.
- c. Welding shall conform to the WPS for in-service welding or the when issued by field engineering the in-service welding plan.

### 11.3 Welding

Figures 1-4 show typical welding sequences and types of welds for reinforcement and repair fittings. Refer to Section 8 of this manual for weld inspections. For transmission lines also refer to GS 1730.010 "Transmission Line Field Repair".

#### 11.3.1 Non-encirclement Reinforcement and Fittings

All non-encirclement reinforcement or fittings shall be centered and squared to the header pipe. Four tack welds shall each be place halfway between the skirt and the crotch of the fitting. The weld sequence is shown in Figure 1. All vent holes in reinforcement fittings shall be plugged with non-pressure retaining material.

#### 11.3.2 Type A Full-encirclement Fittings

All dents and grooves shall be filled with epoxy resin before a type A non-pressurized full-encirclement sleeve is install. The longitudinal welds shall be completed before the epoxy has hardened using passes with very little weave. A backing tape or ring may be used during fitting and welding. The longitudinal welds should be completed at the same time when possible. Type A full-encirclement sleeves shall not be fused to the pipe. No circumferential fillet welds shall be made. The sleeve ends shall be sealed with approved material to prevent crevice corrosion.

Examples of type A reinforcements are branch connection reinforcement, sleeve and saddle, and welded split sleeve. These are used for branch reinforcement and non-pressurized repair of dent, grooves and gouges in the pipe body.

Welding shall follow the sequences given in Figure 1 for branch connections.

#### 11.3.3 Type B Full-encirclement Fittings

Type B full-encirclement fittings shall be designed to withstand the full MAOP of the pipeline. They are used for plugging operations and pipeline leak repair in couplings



## NGD Welding Manual

or pipe body. Examples are reducing branch fittings, spherical split tees, tapping and stopple fittings, weld over coupling sleeve and welded split sleeve.

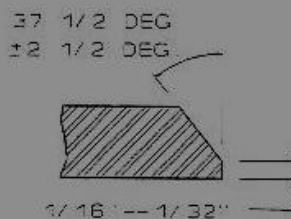
The longitudinal seams shall be welded first using passes with very little weave. The longitudinal welds should be welded at the same time when possible. If one welder is available, then alternating after each pass to the other longitudinal weld shall be performed. Backing tape or rings may be used. The end fillet welds shall then be completed.

### 11.4 Pressure Testing

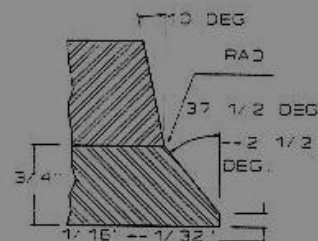
Refer to GS 1500.010 "Pressure Testing."



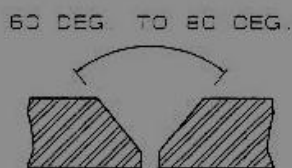
**Fig. 1** Standard End Prep. for API Pipe



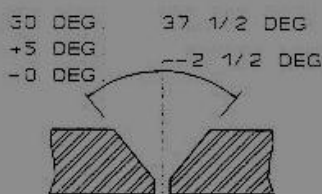
**Fig. 2** Standard End Prep. for ASME/ANSI, 7/8" WT and less



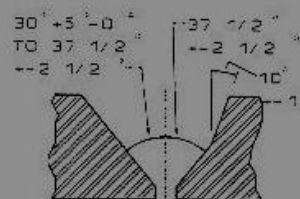
**Fig. 3** End Preps. for all Specs. over 7/8" WT



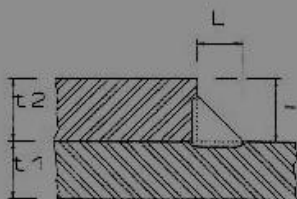
**Fig. 4** Preferred End Prep. Combination



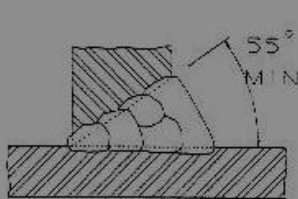
**Fig. 5** Acceptable End Prep. Combination



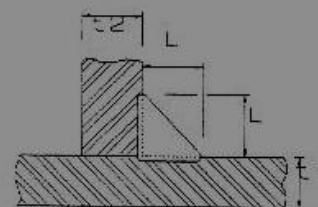
**Fig. 6** Acceptable End Prep. Combination



**Fig. 7** Lap Joint Fillet Weld

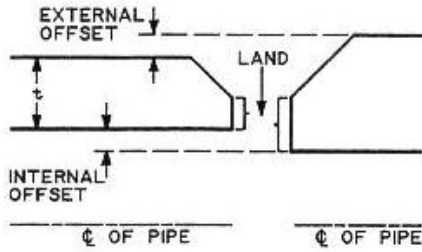


**Fig. 8** Single Bevel Tee



**Fig. 9** Single Fillet Tee

**Exhibit 1 – Weld Joints and Types**



Note:  $T_D$  = Min. Req'd thickness of thicker piece per design.  $T_D$  Max.  $\leq 1.5 \times$  thinner section.

Fig. 1

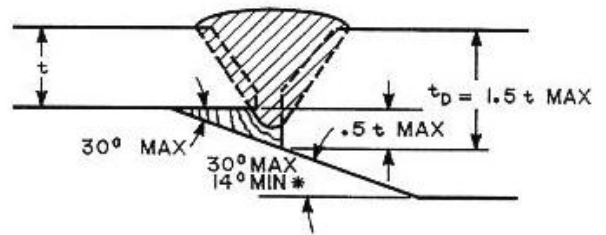


Fig. 5

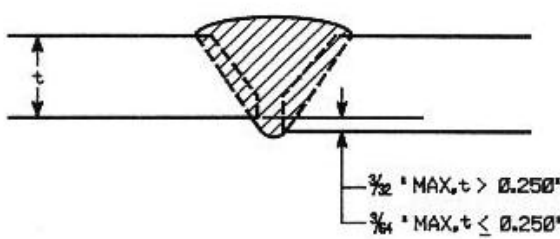


Fig. 2

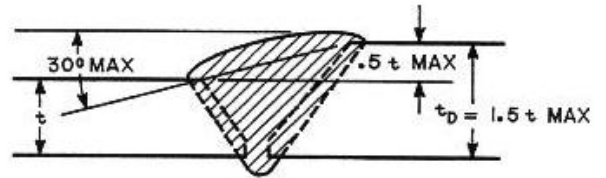


Fig. 6

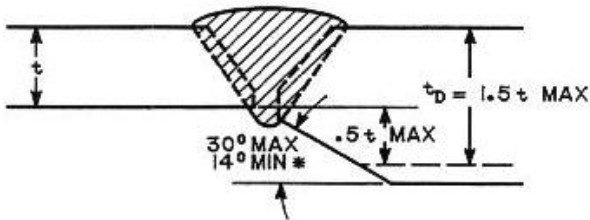


Fig. 3

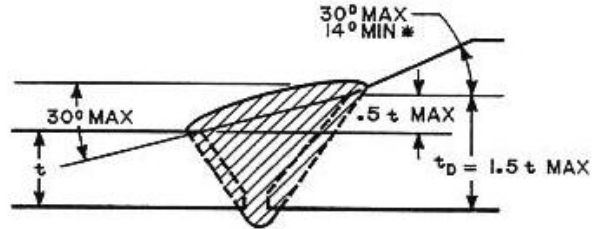


Fig. 7

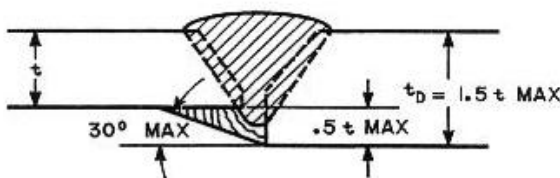


Fig. 4

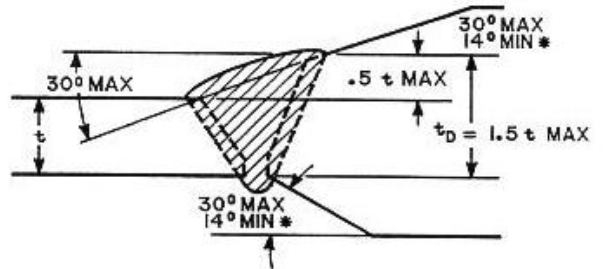


Fig. 8

**Exhibit 2 – Acceptable Design for Unequal Wall Thickness**

## Explanatory Notes For Exhibit 2

1. Butt welding should be performed on pipe, which is aligned concentrically.
2. Exhibit 2 illustrates acceptable end preparations for butt welding pipe of unequal wall thicknesses and/or unequal SMYS.
3. Exhibit 2, Fig. 1 illustrates the terminology used herein.
4. All inner diameters, outer diameters, and wall thicknesses are to be considered nominal.
5. The thickness of the sections to be joined, beyond the joint design area, should comply with the design operating requirements of the pipeline.
6. When the SMYS of the sections to be joined are not equal, the deposited weld metal should have mechanical properties at least equal to those of the section with the higher strength.
7. The transition between ends of unequal thickness may be accomplished by tapering, welding (as illustrated), or by means of a prefabricated transition ring.
8. Sharp notches or grooves at the edge of the weld should be avoided.
9. There is no recommended minimum taper angle for pipe of equal SMYS.
10.  $t_D$  is the thickness of the thicker section in accordance with the steel pipe design equation in Part 192.105.  $t_D$  shall not exceed 1.5 times the thickness of the thinner wall section.
11. As used herein, internal offset is the difference between the inside radii of the pipes and external offset is the difference between the outside radii of the pipes.

**Exhibit 2 – Acceptable Design for Unequal Wall Thickness (continued)**

**Page 2 of 3**



### UNEQUAL INTERNAL DIAMETERS

1. If the internal offset is not more than  $3/32$ " ( $3/64$ " for  $t$  equal to or less than  $1/4$ " (0.250")), special treatment is not necessary [See Exhibit 2, Fig. 2].
2. If the internal offset is more than  $3/32$ " and there is no access for welding internally, transition should be made by a taper cut on the inside end of the thicker section. The taper angle should not be less than 14 degrees (unless pipes are of equal SMYS) nor more than 30 degrees [See Exhibit 2, Fig 3].
3. If the internal offset is more than  $3/32$ ", but not greater than  $1/2$  the thickness of the thinner section, and there is access for welding internally, the transition may be made with a tapered weld, as shown in Exhibit 2, Fig. 4. The land [See Exhibit 2, Fig. 1] of the thicker section must be equal to the offset plus the land on the abutting section.
4. If the internal offset is more than  $1/2$  the thickness of the thinner section and there is access for welding internally, the transition may be made with a taper cut on the inside end of the thicker section, as shown in Exhibit 2, Fig. 3, or by a combination taper weld to  $1/2$  the thickness of the thinner section and a taper cut from that point, as shown in Exhibit 2, Fig. 5.
5. If the wall thickness of either pipe joint is  $1/4$ " or less, the maximum allowable offset is  $3/64$ ".

### UNEQUAL EXTERNAL DIAMETERS

1. If the external offset is not more than  $1/2$  the thickness of the thinner section, the transition may be made by welding, as shown in Exhibit 2, Fig. 6, as long as the angle of rise of the weld surface is not more than 30 degrees and both bevel edges are properly fused.
2. If the external offset is more than  $1/2$  the thickness of the thinner section, that portion of the offset over  $.5t$  should be tapered, as shown in Exhibit 2, Fig. 7.

### UNEQUAL INTERNAL AND EXTERNAL DIAMETERS

If there is both an internal and an external offset, the joint design should be a combination of the above, similar to Exhibit 2, Fig. 8. Particular attention should be paid to proper alignment under these conditions.

**Exhibit 2**  
**Page 3 of 3**



## NDO Welding Manual

| <b>Visual Examination Requirements</b>                             |   |  |
|--|---|--|
| <b>Discontinuity</b>   | <b>Butt Welds</b>   | <b>Fillet Welds</b>  |
| Cracks   | None Permitted  | None Permitted   |
| Inadequate Penetration   | None Permitted  | None Permitted   |
| Burn-Through   | None Permitted  | N/A  |
| Weld Reinforcement (where the thinner component is 1/2" and under) | 1/8" Maximum<br>(1/16" desired)   | N/A  |
| Weld Reinforcement (where the thinner component is above 1/2")     | 3/16" maximum<br>(1/16" desired)  | N/A  |
| Overlap  | 1/16" minimum - 1/8" maximum  | N/A  |
| Internal Concavity   | Shall not reduce the total thickness of the joint, including reinforcement, to less than the thickness of the thinner component | N/A  |
| Arc Strikes (Burns)  | None Permitted  | None Permitted   |
| Low Cap/Cover  | None Permitted  | N/A  |
| Internal Build-up  | 3/32" maximum   | N/A  |
| Porosity   | None Permitted  | None Permitted   |
| <b>Undercutting</b>  | <b>IF THE DEPTH IS:</b>   | <b>LENGTH</b>  |
| Butt Weld (EU & IU)<br>Fillet Weld (EU Only)                       | Over 1/32" or over 12.5% of wall thickness  | None Acceptable  |
|  | Over 1/64" or over 6% of wall thickness, but not over 1/32" or 12.5% of wall thickness  | Total of IU plus EU shall not exceed 2" in any 12" length or 1/6 the weld length |
|  | 1/64" or less and 6% or less of wall thickness  | EU is acceptable<br>Consider only IU   |
| <b>NOTE:</b> Welds must have a neat appearance                     |   |  |

**Exhibit 3 – Visual Examination Requirements**



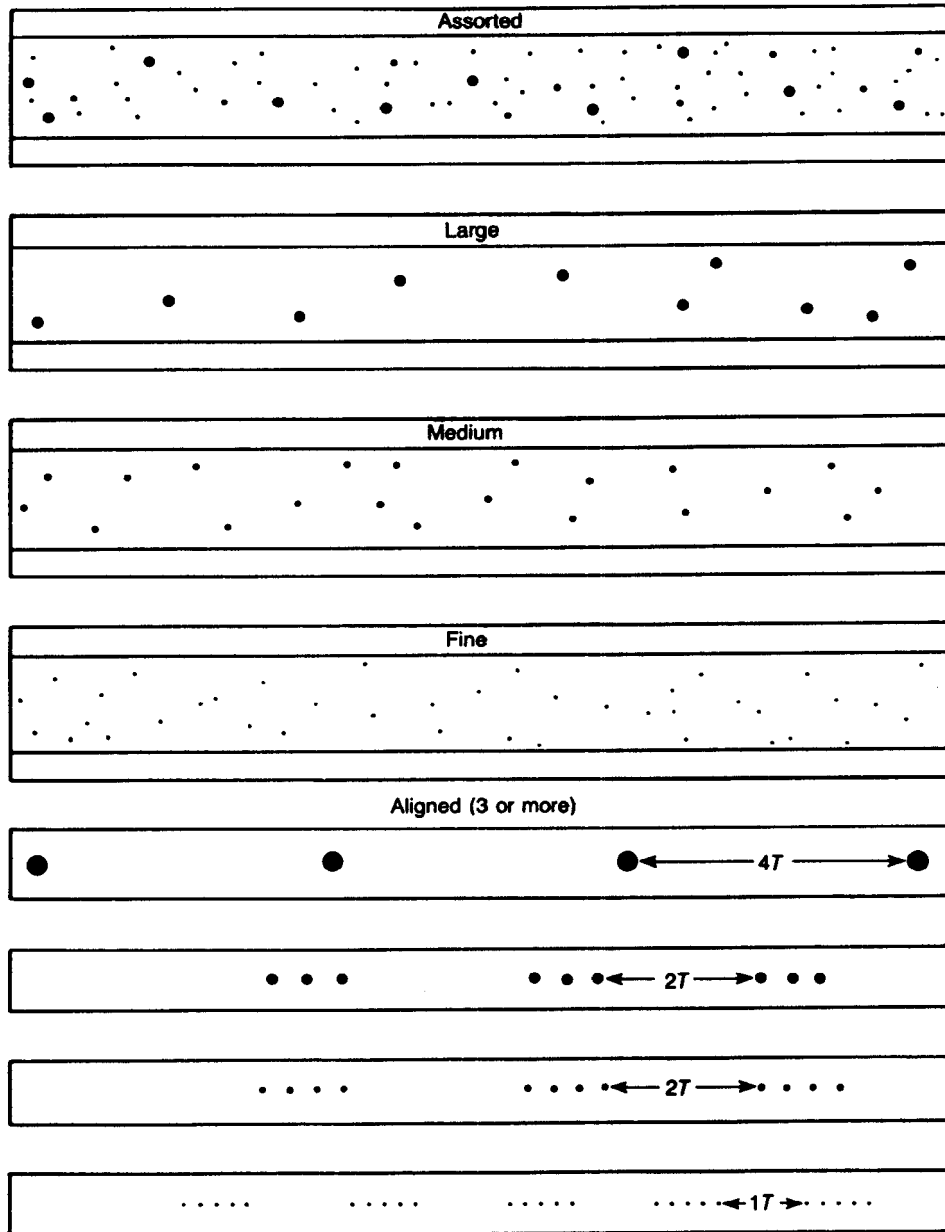
# NDO Welding Manual

| Non-destructive Testing Standards Of Acceptability For Welds In Pipelines And Mains<br>(Note: Acceptance standards comparable to API 1104, 20th Edition.)                              |      |   |   |  |
|--|------|---|---|--|
| Type Of Discontinuity  | Abrv | Individual Size (1)   | Total Length (1)  | Special Under 2-3/8" O.D.(1)   |
| <b>Inadequate Penetration without high-low</b>   | IP   | Shall not exceed 1" or 8% of weld length.   | Total length shall not exceed 1" in 12", or 8% of weld length.  |  |
| <b>Inadequate Penetration Due To High-Low</b>  | IPD  | Shall not exceed 2" or 16% of weld length.  | Total length shall not exceed 3" in 12", or 16% of weld length.   |  |
| <b>Incomplete Fusion</b>   | IF   | Shall not exceed 1" or 8% of weld length.   | Total length shall not exceed 1" in 12", or 8% of weld length.  |  |
| <b>Incomplete Fusion Due To Cold Lap</b>   | IFD  | Shall not exceed 2" or 8% of weld length.   | Total length shall not exceed 2" in 12", or 8% of weld length.  |  |
| <b>Internal Concavity</b>  | IC   | Any length, as long as the radiographic image of the "IC" is lighter than that of the thinnest adjacent base metal. If darker than that of the thinnest adjacent base metal, the dimensions of the IC shall not exceed that specified for burn-through. |   |  |
| <b>Burn-Through</b><br>Considered "BT" only if the radiographic image is darker than that of the thinnest adjacent base metal.   | BT   | Shall not exceed 1/4" or t in any dimension. (2)  | Total of the maximum dimensions of separate BT's shall not exceed 1/2" in any 12", or 1/2" if the total weld length is less than 12"                            | Only one BT is allowed, which shall not exceed 1/4" or t in any dimension. (2)   |
| <b>Elongated Slag Inclusion</b><br>(Continuous, broken or parallel): Parallel "ESI" (wagon tracks) shall be considered as separate ESI's if the width of either one exceeds 1/32". (3) | ESI  | Length shall not exceed 2" or 8% of weld length. Width shall not exceed 1/16". (If width exceeds 1/16", acceptance standards for ISI may apply.)  | Total length of ESI plus ISI shall not exceed 2" in 12", or 8% of weld length.  | Length shall not exceed 3t or 8% of weld length. (2)<br>Width shall not exceed 1/16".<br><br>Total length of ESI plus ISI shall not exceed 8% of the weld length.        |
| <b>Isolated Slag Inclusion</b><br>(Irregularly shaped)<br>(3)n   | ISI  | Length shall not exceed 1/2" or 8% of weld length. (If longer, acceptance standards for ESI may apply.) Width shall not exceed 1/8".  | Total length of "ISI" shall not exceed 1/2" in 12", or 8% of weld length.<br><br>Total length of ESI plus ISI shall not exceed 2" in 12", or 8% of weld length. | Length shall not exceed 2t or 8% of weld length. (2)<br><br>Width shall not exceed 1/2t. (2)<br><br>Total length of ESI plus ISI shall not exceed 8% of the weld length. |
| <b>Porosity</b> (individual or scattered)  | P    | Maximum dimension shall not exceed 1/8" or 1/4t. (2)<br>Maximum distribution shall not exceed concentration shown in Exhibit 3 or 4   |   |  |
| <b>Cluster Porosity</b><br>(Finish pass only); "CP" in other passes shall comply with P requirements.  | CP   | Cluster diameter shall not exceed 1/2", with the maximum dimension of any individual pore within the cluster not to exceed 1/16".   | Total combined length of clusters shall not exceed 1/2" in 12", or 8% of weld length.   |  |
| <b>Hollow Bead</b>   | HB   | Shall not exceed 1/2" or 8% of weld length.   | Total length shall not exceed 2" in 12", or 8% of weld length. Individual HB's which exceed 1/4" in length shall be separated by at least 2".                   |  |
| <b>Crack</b>   | C    | None, regardless of size or location, except crater cracks less than 5/32" in length.   |   |  |
| <b>External Undercutting</b>   | EU   | Total length of "EU" plus "IU" shall not exceed 2" in 12", or 1/6 of the weld length. If the undercutting can be mechanically measured, special acceptance criteria found in Exhibit 1 may be applied.  |   |  |
| <b>Internal Undercutting</b>   | IU   |   |   |  |
| <b>Accumulation Of Discontinuities</b>   | AD   | N/A   | Excluding IPD, EU, and IU, total length shall not exceed 2" in 12", or 8% of weld length.   |  |
| <b>Arc Strike</b> (Arc Burn)   | AS   | None allowed. Welding Inspector must be consulted for disposition.  |   |  |
| <b>Low Cap</b>   | LC   | If indicated radiographically, image shall not exceed 1/4" or t in any dimension. (2)   |   |  |

NOTES: (1) If more than one acceptance standard is given for a discontinuity, the most restrictive shall apply.  
 (2) "t" is the thinner of the nominal wall thicknesses joined.  
 (3) When the size is measured, the indication's maximum dimension shall be considered its length.

**Exhibit 3 – Standards of Weld Acceptability**  
**Page 2 of 4**

# NDO Welding Manual

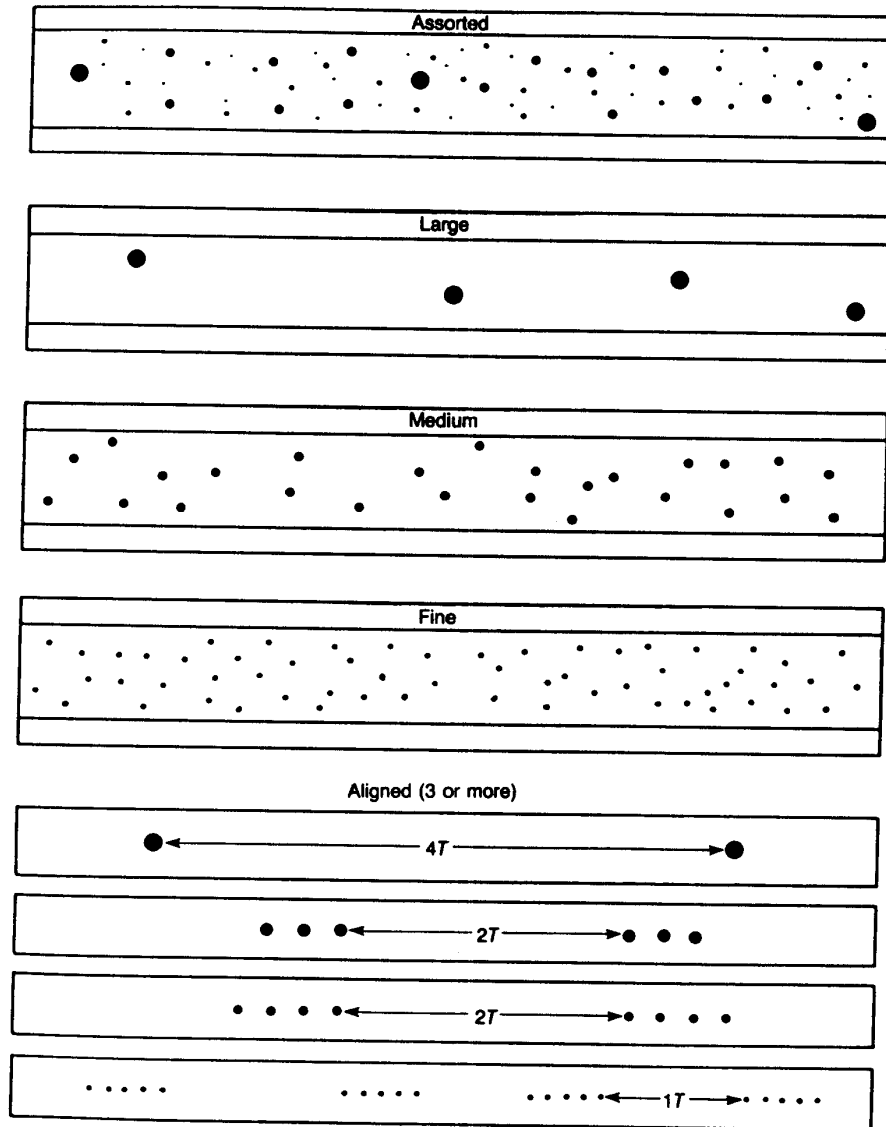


NOTE: The size of the porosity is not drawn to scale.

**Exhibit 3 – Maximum Distribution of Porosity: Wall Thickness 1/2" or Less**

**Page 3 of 4**

# NDO Welding Manual



NOTE: The size of the porosity is not drawn to scale.

**Exhibit 3 – Maximum Distribution of Porosity: Wall Thickness Over 1/2"**

**Page 4 of 4**



# NDO Welding Manual

## **Welding Permit**

Name \_\_\_\_\_

ID No. \_\_\_\_\_ D.O.B. \_\_\_\_\_

*Is qualified as follows:*

Process \_\_\_\_\_

Position \_\_\_\_\_

Pipe Diameter range \_\_\_\_\_

Wall thickness range \_\_\_\_\_

Maximum Grade \_\_\_\_\_

Additional Qualification \_\_\_\_\_

\_\_\_\_\_  
DATE

\_\_\_\_\_  
WELDING INSTRUCTOR

### 6 Month Test Information

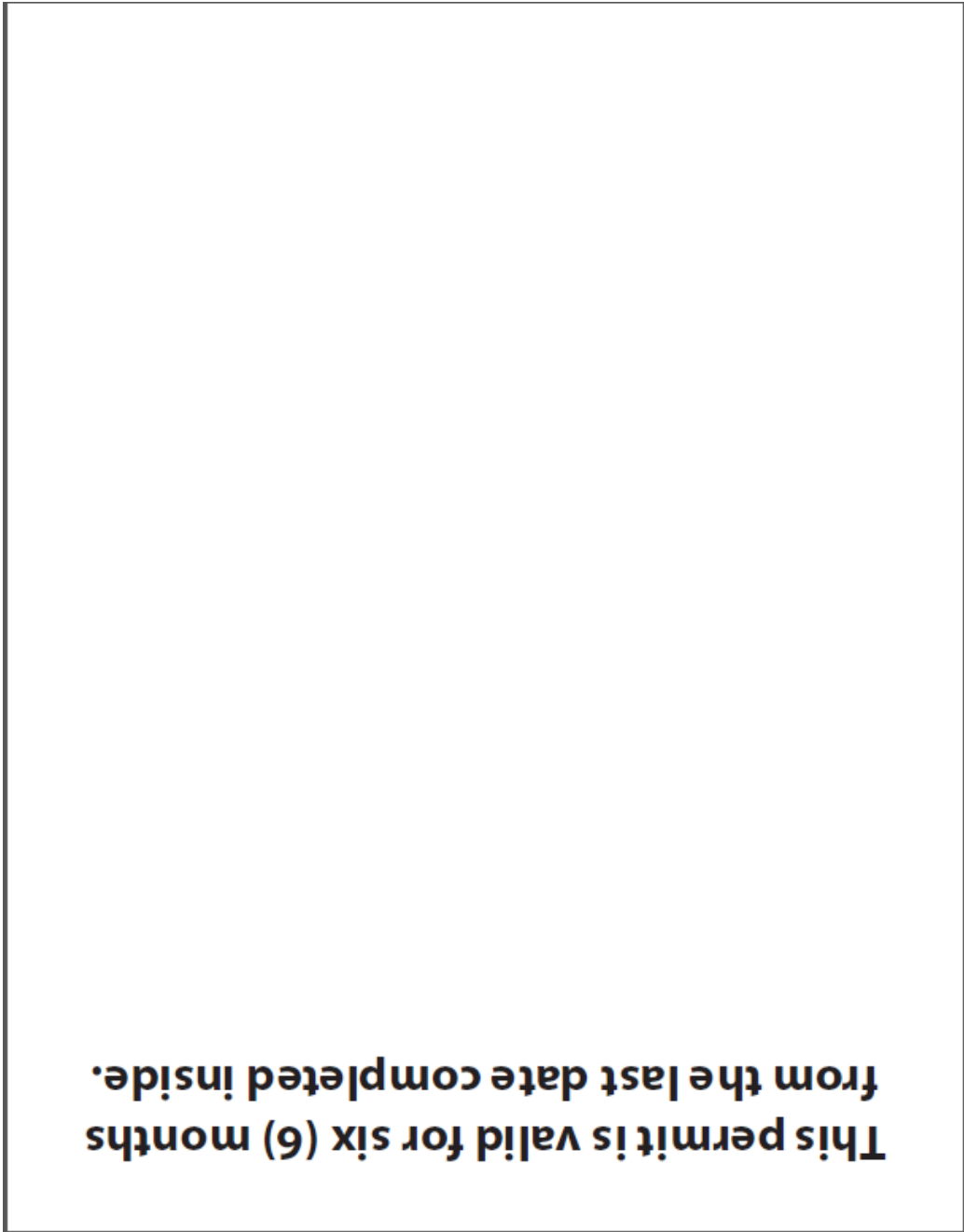
| Type of test | Due date | Date completed | Welding instructor |
|--------------|----------|----------------|--------------------|
|              |          |                |                    |
|              |          |                |                    |
|              |          |                |                    |
|              |          |                |                    |

FORM GS 1200-1 (03/2013)

Exhibit 4 - Welding Permit

Page 1 of 2

## NDO Welding Manual



**Exhibit 4 – Welding Permit**  
**Page 2 of 2**



## NDO Welding Manual

| Operation  | Elec. Size<br>(X 1/32" or (X mm))        | Arc<br>Current<br>(Amps)      | Min.<br>Shade | Sugg*<br>Shade    |
|--|--|-------------------------------|---------------|-------------------|
| SMA Welding  | < 3                                      | < 60                          | 7             | 8                 |
|  | 3-5 (2.5-4)                              | 60 -<br>160                   | 8             | 10                |
|  | 6-8 (4-6.4)                              | 160-<br>250                   | 10            | 12                |
|  | >8 (6.4)                                 | > 250                         | 11            | 14                |
| GMA Welding and<br>FCA Welding   |  | < 60                          | 7             | 8                 |
|  |  | 60-160                        | 10            | 11                |
|  |  | 160-<br>250                   | 10            | 12                |
|  |  | > 250                         | 10            | 14                |
| GTA Welding  |  | < 50                          | 8             | 10                |
|  |  | 50-150                        | 8             | 12                |
|  |  | > 150                         | 10            | 14                |
| Air Carbon Arc Cutting   | (Light)<br>(Heavy)                       | < 500<br>> 500                | 10<br>11      | 12<br>14          |
| Plasma Arc Welding   |  | < 20                          | 6             | 8                 |
|  |  | 20-100                        | 8             | 10                |
|  |  | 100-<br>400                   | 10            | 12                |
|  |  | > 400                         | 11            | 14                |
| Plasma Arc Cutting   | (Light)**<br>(Medium)**<br><br>(Heavy)** | < 300<br>300-<br>400<br>> 400 | 8<br>9<br>10  | 9<br>12<br>14     |
| Torch Brazing<br>Torch Soldering   |  |                               |               | 3-4<br>2          |
|  | <b>Plate Thickness</b>                   |                               |               |                   |
|  | (in)                                     |                               |               | (mm)              |
| OAW (light)  | < 1/8                                    | < 3.2                         |               | 4-5               |
| OAW (medium)   | 1/8 - 1/2                                | 3.2 -12.                      |               | 5-6               |
| OAW (heavy)  | > 1/2                                    | > 12.                         |               | 6-8               |
| Oxy-fuel Cutting<br>(light)<br>(medium)<br>(heavy)   | < 1<br>1 - 6<br>> 6                      | < 25<br>25-150<br>> 150       |               | 3-4<br>4-5<br>5-6 |
| <p>* As a rule of thumb, start with a shade that is too dark to see the weld zone. Then go to a lighter shade, which gives sufficient view of the weld zone without going below shade 3 as the minimum. In oxy-fuel operation where the torch produces a yellow light, it is desirable to use a filter lens that absorbs the yellow or sodium line in the visible light spectrum.</p> <p>** These values apply where the actual arc is clearly seen. Experience has shown that lighter filters may be used when the arc is hidden by the work piece.</p> |  |                               |               |                   |

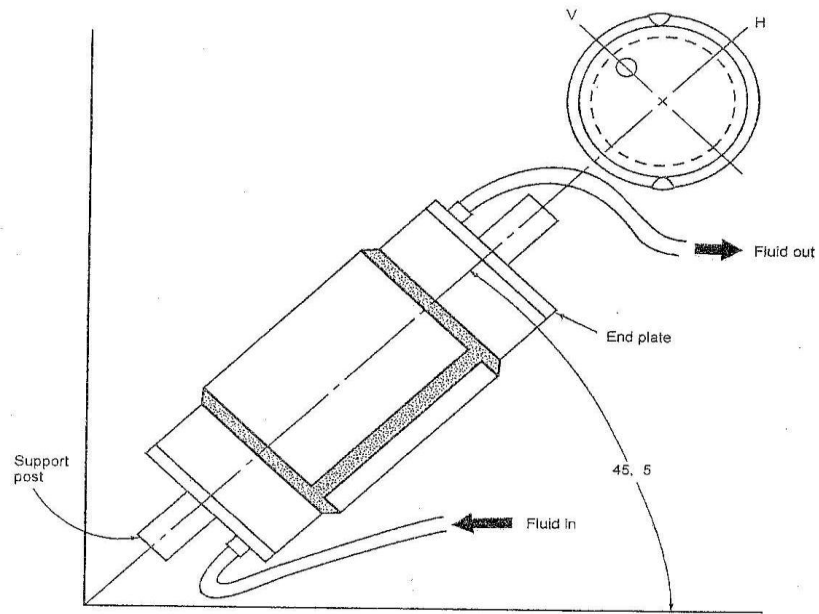
**Exhibit 5**  
**Guide For Shade Numbers and Plate Thicknesses**



# NDO Welding Manual

WELDING OF PIPELINES AND RELATED FACILITIES

65



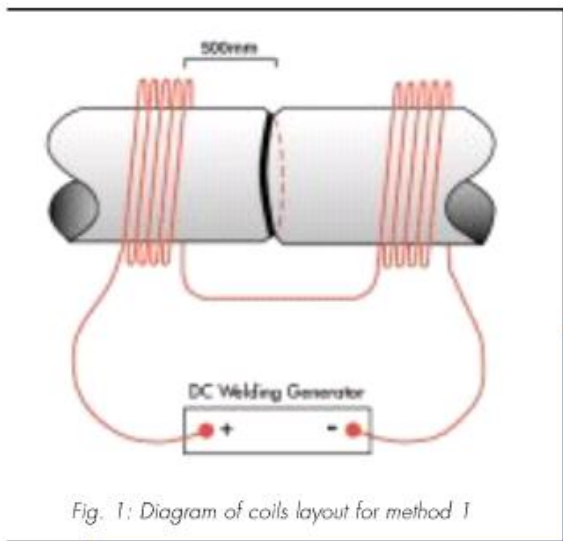
Note: This test position qualifies the procedure for all positions. Tests may be performed in other positions which will qualify the procedure for that position only.

**Exhibit 6 - In-service Welder Test**

## NDO Welding Manual

### Method One: The two welding generator approach

One method of reducing residual magnetism in pipe work is to induce a compensating magnetic field during the welding process with a second welding generator. This method is employed when welding cannot be completed quickly. By maintaining this compensating field throughout the welding procedure, the risk of arc blow is eliminated. Using this method of demagnetization, the residual magnetic field is opposed by the induced field, reducing overall pipe magnetism to low levels. These are the minimum equipment requirements to carry out this operation: Flexible welding cable, 300 amp. capacity. Aluminum cored cable is not recommended for this procedure. 1x Standard DC Welding Generator for field compensation. It is important that the current output is smooth DC and controllable down to approximately 10 amps. 1x Standard AC or DC Welding Generator for welding. PII Gauss Indicator or Gauss Meter, range between 10 to 1000 Gauss. Do not attempt this procedure with-out one.



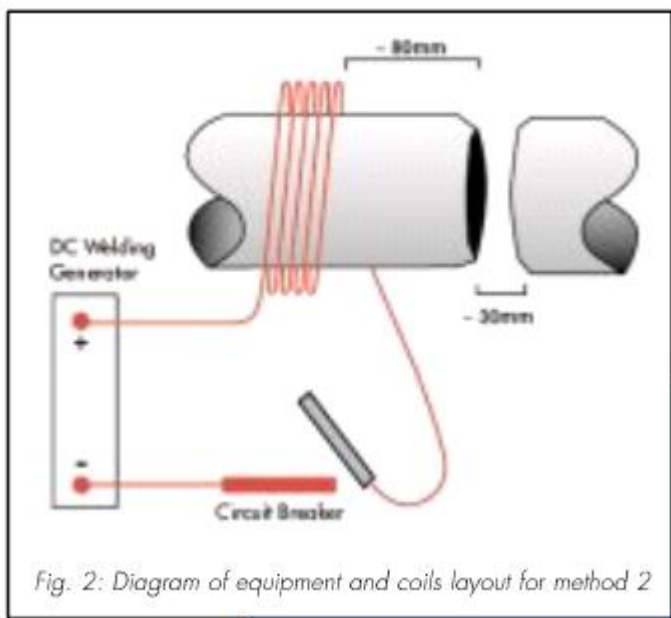
1. With a PII Gauss Indicator or Gauss Meter and a suitable probe, measure the strength and polarity of the magnetic field in the root gap of the joint to be welded. Figure A shows how to measure the magnetic field.
2. Wrap the welding cable around one pipe end to form a tight coil (approximately 10-12 turns). With the same welding cable, form a coil around the other pipe end. The edge of the coils should be within 500 mm of the root gap. The coil should be wound in the same direction for both pipe ends. Figure 1 provides a diagram of the coils layout, and Figure B a picture.
3. Connect the cable ends to the DC welding generator. Then, using the Gauss Indicator or Meter, prepare to read the field in the weld gap. Figure C shows the equipment and coils layout.
4. Set the welding generator current to its lowest setting and switch it on, as shown in Figure D. Slowly increase the current supplied to the coils and observe the reading on the Gauss Indicator or Meter. The field should decrease as the current increases.
5. In the event that the field increases, reverse the lead connections to the generator. This changes the polarity of the induced magnetic field.
6. Continue to increase the current until the field in the weld gap is as close to zero as possible – at least below 20 Oe. This is the point that the induced magnetic field is of equal magnitude to the residual field, but of opposing polarity. Normal welding becomes possible at this point.
7. Throughout the welding of the root pass, ensure that the current to the coils remains on.

### Exhibit 7 - Demagnetization of Pipe

## NDO Welding Manual

### Method Two: When only one generator is available

A second method of demagnetizing a pipeline is to induce a magnetic field that temporarily disrupts the residual magnetism in the pipe prior to normal welding procedures. The advantage of this approach is that a single DC welding generator can do the whole job of demagnetizing the pipe-line and welding the root pass. However, the pipeline remains demagnetized for only a short period of time. If two generators are available, operators may prefer to use method one. This procedure does not permanently demagnetize the pipeline, but instead creates a temporary disruption of the fields to allow the welding process to proceed. After disrupting the field strength to a suit-able level, the operator has about one hour to start the root weld. These are the minimum equipment requirements to carry out this operation: Flexible welding cable, 300 amp. capacity. Aluminum cored cable is not recommended for this procedure. Standard DC Welding Generator • PII Gauss Indicator or Gauss Meter, range between 10 to 1000 Gauss. Do not attempt this procedure without one.



1. Before starting, ensure that all pipe components are fully prepared and sized for the proposed tie-in, as time is limited. Separate all components by at least 300mm. Figure 2 provides a diagram of the pipeline layout; Figure A, a picture.
2. The PII Gauss Indicator or Gauss Meter probe should be in gentle contact with the pipe and aligned such that it measures the field strength in line with the pipe axis. Identify the position around the circumference where the field is at its maximum, then mark the location and note and reading polarity. Figure B shows how to measure the magnetic field.
3. Wrap the welding cable around the pipe to form a tight coil (approximately 18-20 turns). The edge of the coil should be within 80 mm from the pipe end being demagnetized. Figures 2 and C show the coil layout.

## NDO Welding Manual

4. Connect the DC welding generator out-put to one end of the cable and complete the circuit by connecting the stick holder to the earthing clamp with a suitable piece of steel plate – see Figure D. This should be done such that it facilitates its use as a circuit breaker at a later stage. Figure E shows a picture of the equipment and coils layout.
5. Adjust the welding generator to a low current setting, somewhere less than 80amps, and turn it on with the polarity switch. This will change the field strength shown on the Gauss Indicator or Meter. If the reading decreases or reverses, note the position of the polarity switch, for use in step 6, and turn the welding generator off. If the reading increases then repeat step 5, this time with the polarity switch reversed. Then follow the earlier instructions – note the position of the switch and turn the generator off.
6. Adjust the current setting control to zero. Turn on the generator with the polarity switch, and set it to the position established in step 5. Quickly increase the current supply to the coil to 300 amps and hold for ten seconds. Switch off by breaking the [stick holder](#)/earthing clamp joint to cause an immediate interruption in the current. Do not reduce the current gradually, as the interruption speed of the applied field produces the required changes. Switch off the welding generator in the normal manner, as shown in Figure F.
7. Observe the field strength and direction at the position noted in step 2. Compare this reading to the original. The field strength should be reduced or reversed. See Figure G. If the reading is less than 20 Oe, then DC welding is possible without further demagnetization.
8. If the reading is less than 100 Oe there is a choice of either AC welding or continuing further demagnetization by repeating steps 2, 5 and 6 until the field falls below 20 Oe.
9. If the reading is greater than 100 Oe, further demagnetization is necessary. If the polarity has reversed, then repeat steps 2, 5 and 6. If not, return to step 6.
10. If a constant minimum field strength reading is obtained after repeated demagnetization then there is insufficient flux density created by the product of the weld current in amps and the number of turns on the coil. This is a common problem when working on thick wall pipe, usually in excess of 19mm. To overcome this it is necessary to increase the number of turns on the coil, thereby increasing the amp turns. This, in turn, increases the demagnetization penetration. Repeat the whole procedure from step 2, with the ampere product doubled.

## NDO Welding Manual

**Table 1. Minimum length of cable required for demagnetisation**

| Normal Pipe Diameter |        | Minimum length of cable (m*) |        |
|----------------------|--------|------------------------------|--------|
| mm                   | Inches | mm                           | Inches |
| 100                  | 4      | 9                            | 7      |
| 150                  | 6      | 12                           | 10     |
| 200                  | 8      | 16                           | 13     |
| 250                  | 10     | 20                           | 16     |
| 300                  | 12     | 24                           | 19     |
| 350                  | 14     | 28                           | 22     |
| 400                  | 16     | 32                           | 26     |
| 450                  | 18     | 35                           | 29     |
| 500                  | 20     | 39                           | 32     |
| 550                  | 22     | 43                           | 36     |
| 600                  | 24     | 46                           | 38     |
| 750                  | 30     | 58                           | 48     |
| 900                  | 36     | 69                           | 57     |

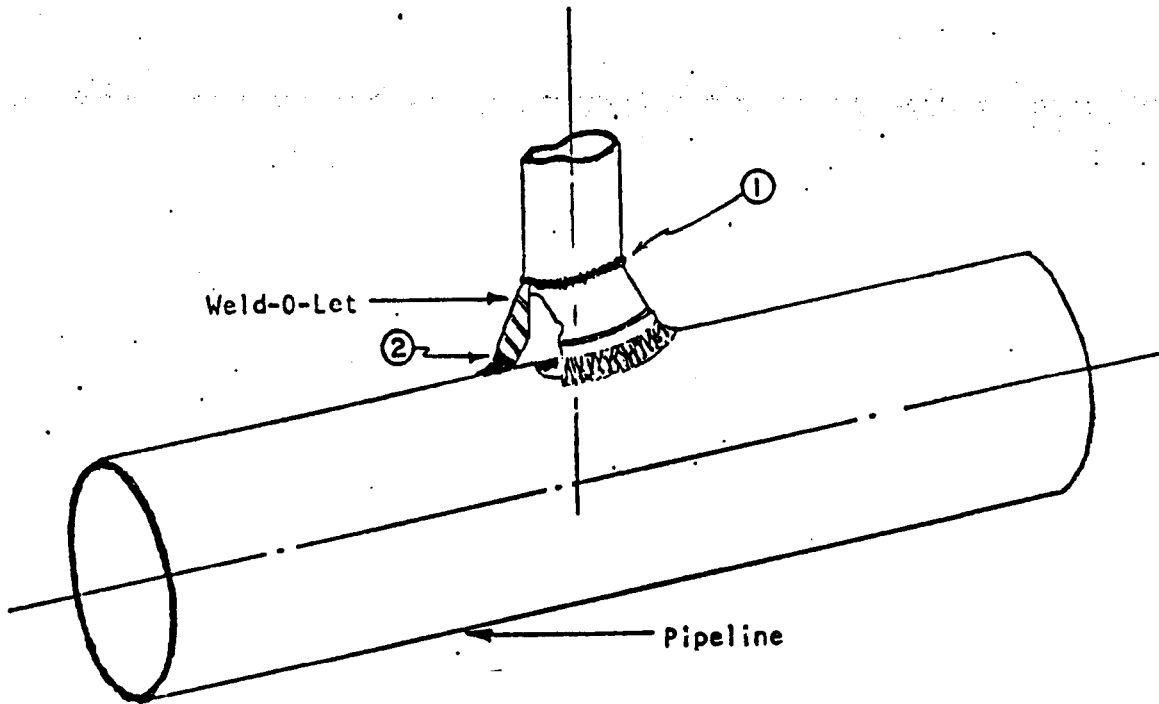
\* These lengths only refer to the coils—further cable is necessary to connect the coil to the welding generators.

Note: Thick wall pipe may need more turns in the coil and so need more cable.

**Exhibit 7 - Demagnetization of Pipe**

**Page 4 of 4**

## NDO Welding Manual

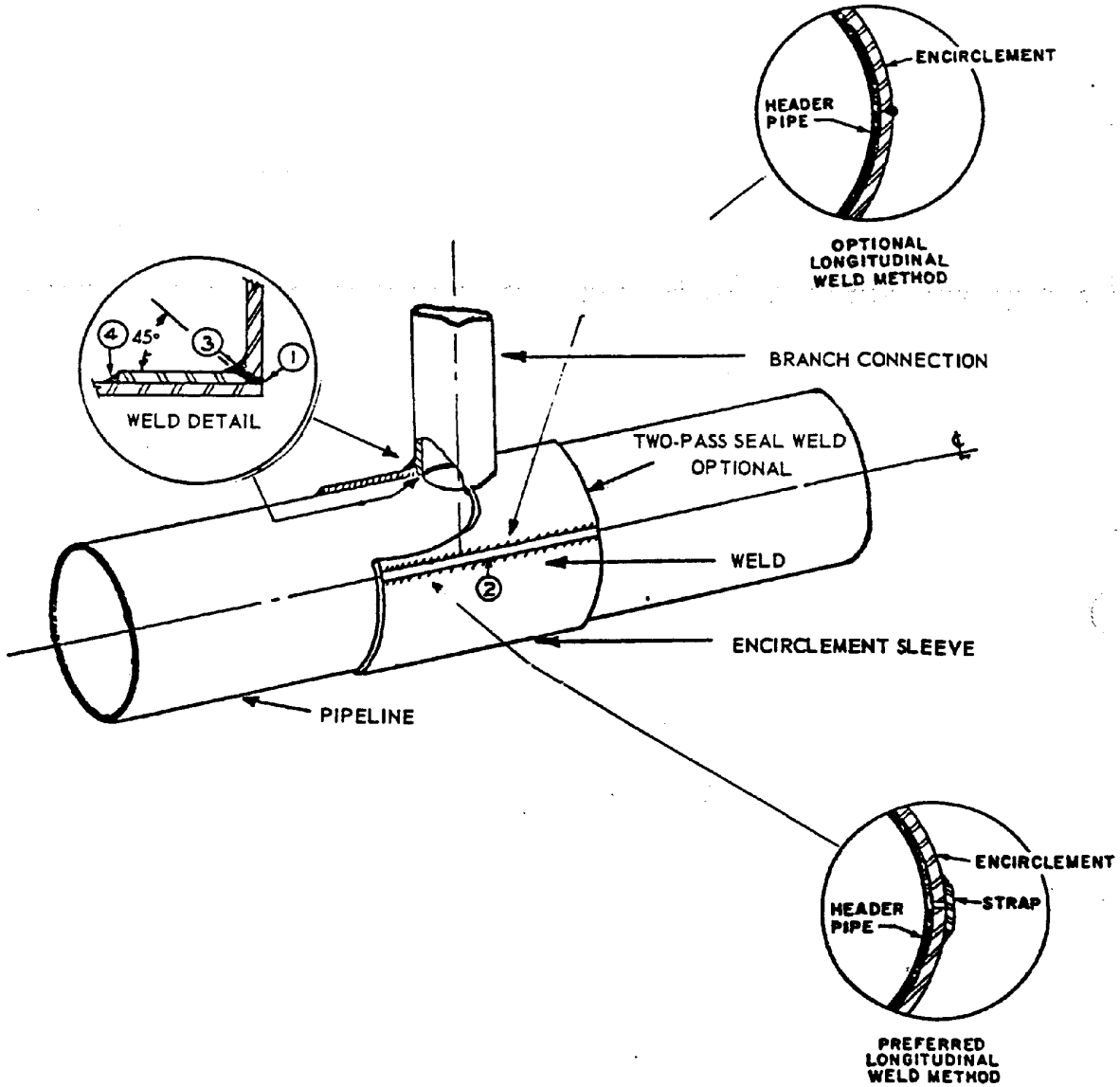


**Notes:**

- A. Numbers Indicate Sequence for depositing welds
- B. For  $\leq 2$ " NPS Taps on Wall thicknesses  $\geq 0.188$ "

**Figure 1 - Weld Sequences**  
**Page 1 of 4**

# NDO Welding Manual

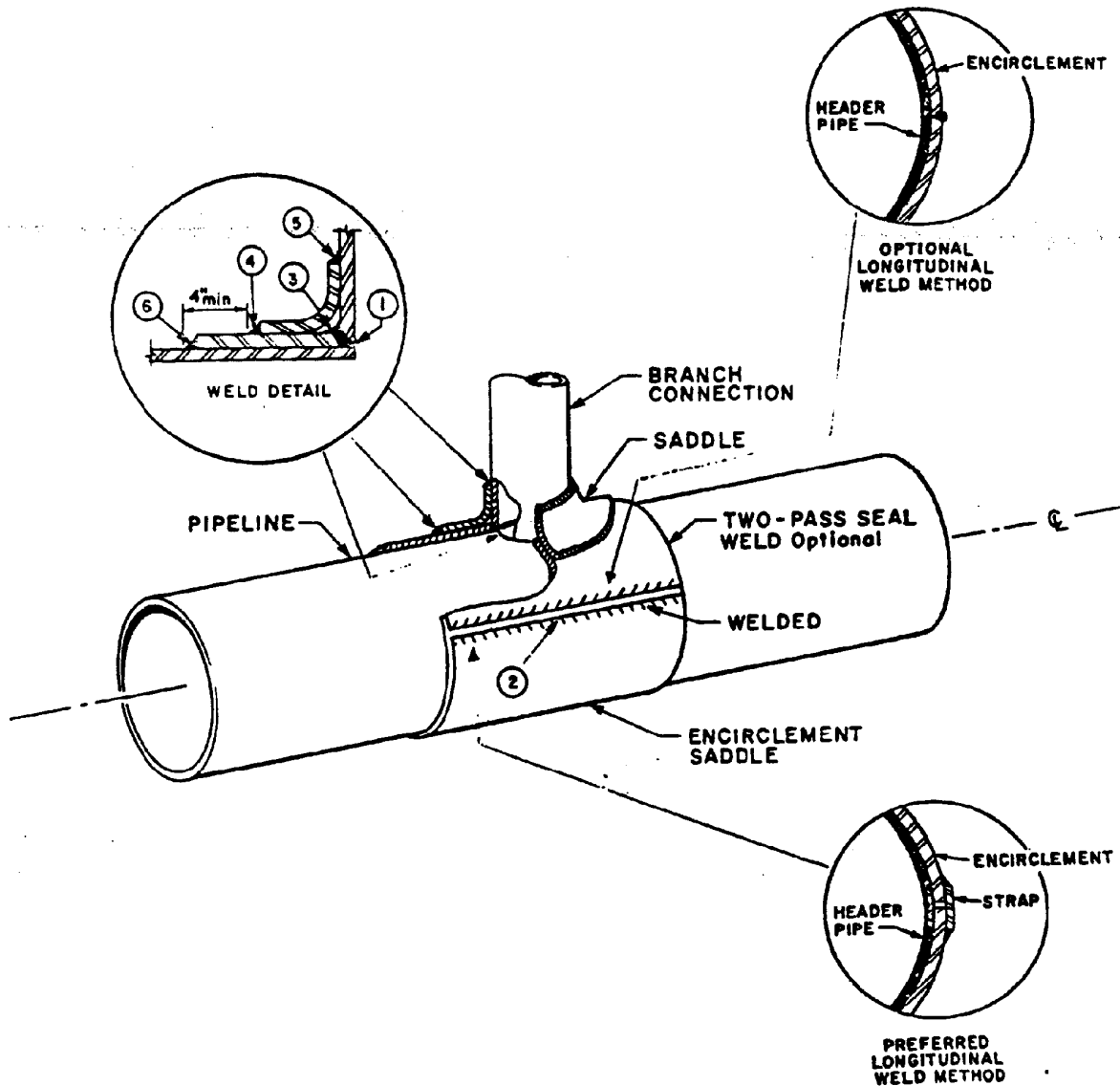


**Notes:**

- A. Numbers indicate sequence for depositing welds
- B. The longitudinal weld must not penetrate into the carrier pipe. A thin piece of sheet metal may be used to prevent welding into the pipeline.
- C. Circumferential fillet weld on ends are for Type B, pressurized fittings only.
- D. If the seal weld is omitted the end of the encirclement sleeve shall be sealed to prevent moisture from seeping under the sleeve.

**Figure 1 - Weld Sequences**

# NDO Welding Manual



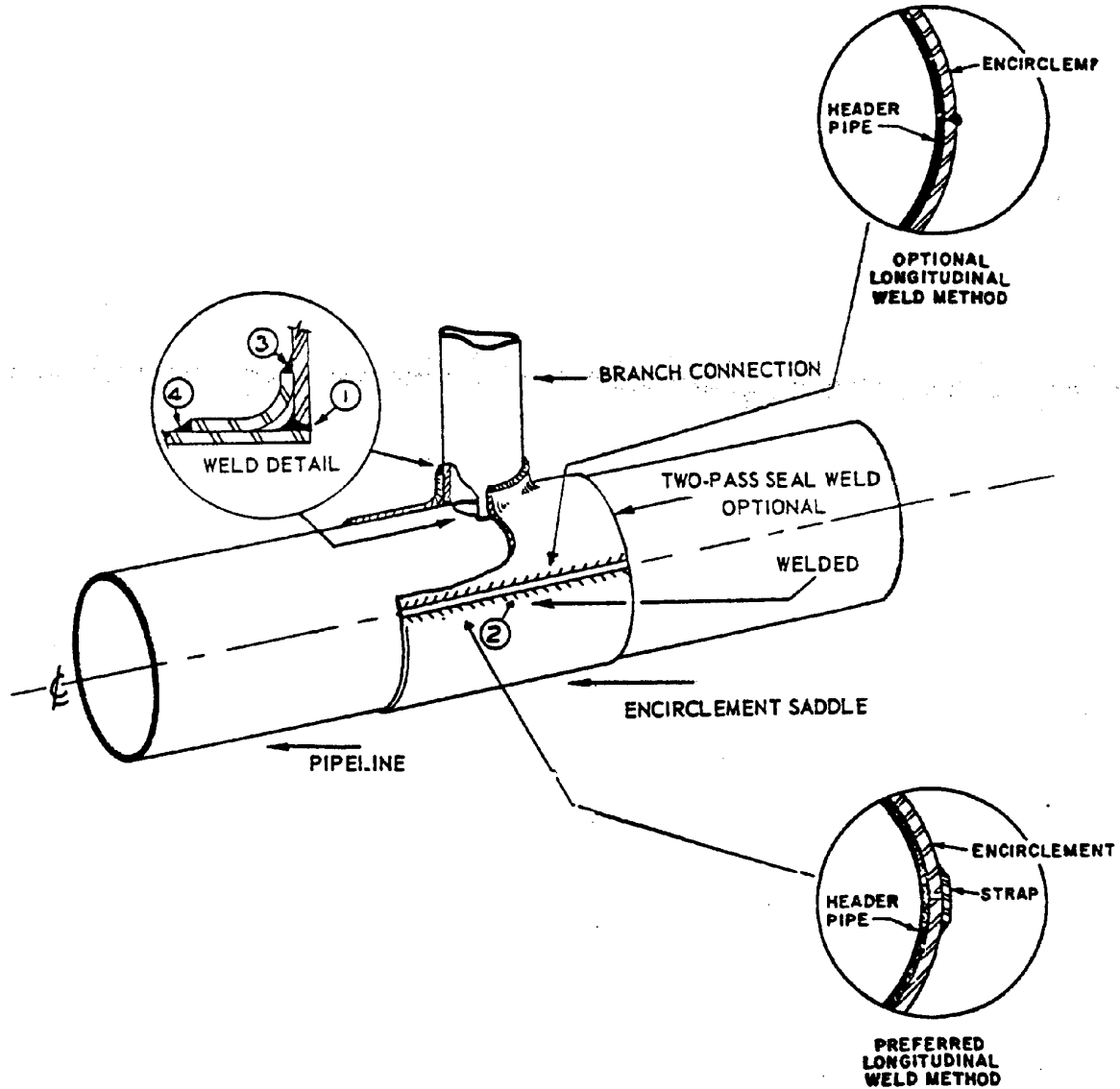
**Notes:**

- A. Numbers indicate sequence for depositing welds
- B. The longitudinal weld must not penetrate into the carrier pipe. A thin piece of sheet metal may be used to prevent welding into the pipeline.
- C. Circumferential fillet weld on ends are for Type B, pressurized fittings only.
- D. If the seal weld is omitted the end of the encirclement sleeve shall be sealed to prevent moisture from seeping under the sleeve.

**Figure 1 - Weld Sequences**



# NDO Welding Manual

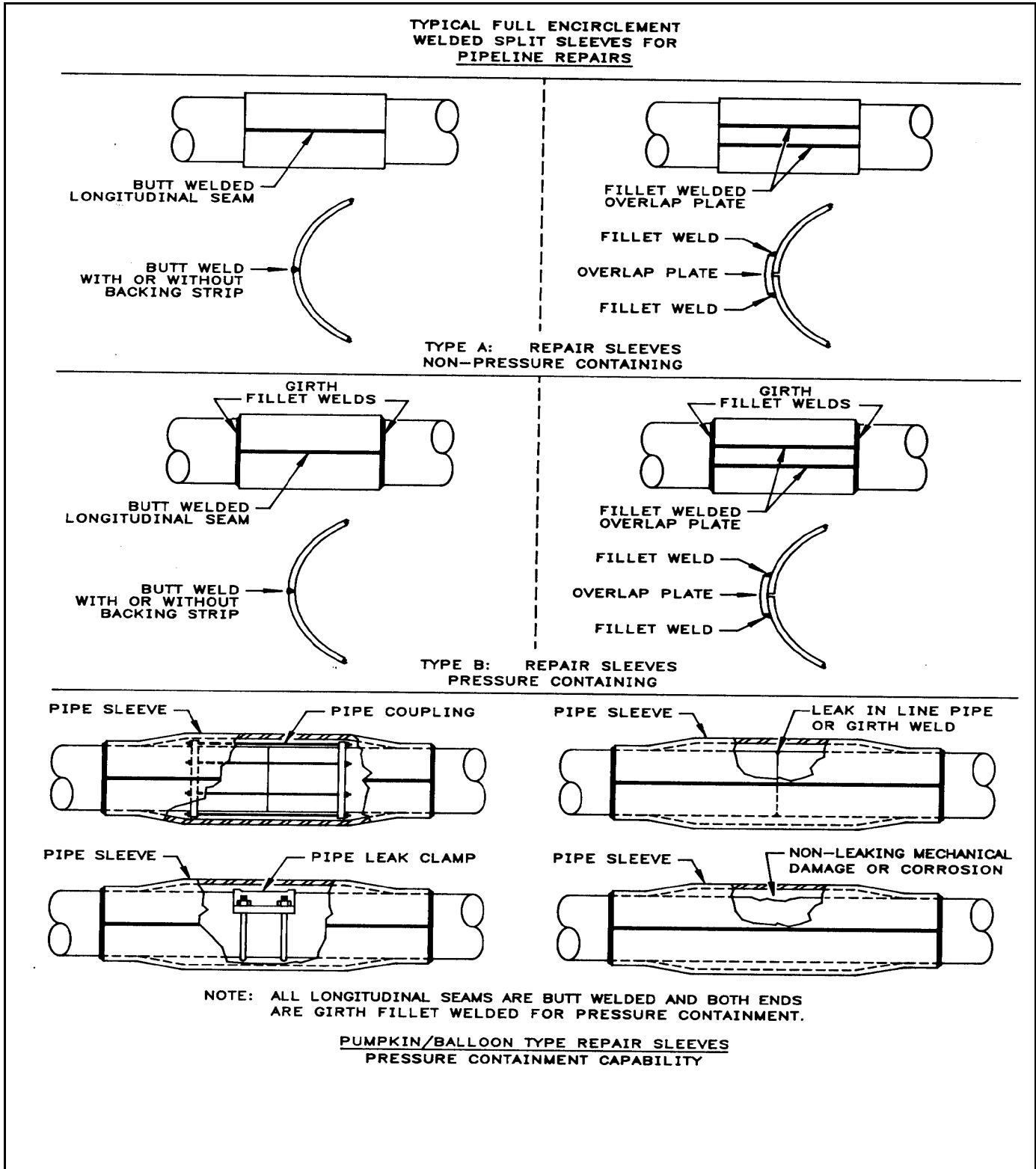


**Notes:**

- A. Numbers indicate sequence for depositing welds
- B. The longitudinal weld must not penetrate into the carrier pipe. A thin piece of sheet metal may be used to prevent welding into the pipeline.
- C. Circumferential fillet weld on ends are for Type B, pressurized fittings only.
- D. If the seal weld is omitted the end of the encirclement sleeve shall be sealed to prevent moisture from seeping under the sleeve.

**Figure 1 - Weld Sequences**

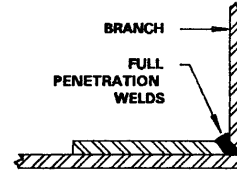
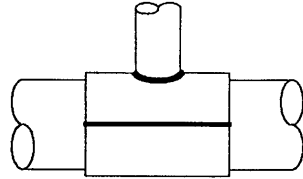
# NDO Welding Manual



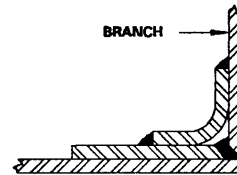
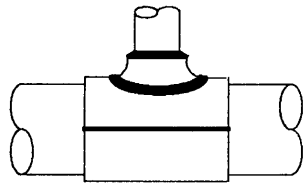
**Figure 2 - Full Encirclement Repair Sleeves**

# NDO Welding Manual

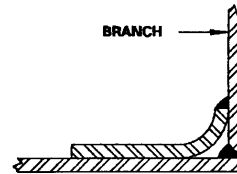
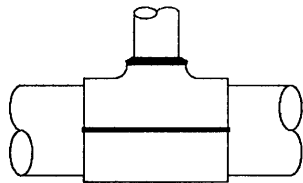
**TYPICAL FULL ENCIRCLEMENT  
WELDED HOT TAP BRANCH CONNECTIONS  
NON-PRESSURE CONTAINING**



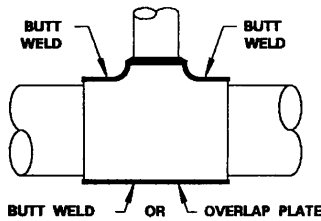
**TYPE A-1: NON-PRESSURE CONTAINING ENCIRCLEMENT SLEEVE  
WITHOUT ADDED BRANCH SUPPORT**



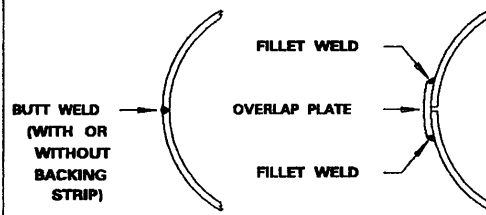
**TYPE A-2: NON-PRESSURE CONTAINING ENCIRCLEMENT SLEEVE  
WITH ADDED BRANCH SUPPORT**



**TYPE A-3: NON-PRESSURE CONTAINING ENCIRCLEMENT SLEEVE  
WITH INTEGRAL BRANCH SUPPORT  
(ENCIRCLEMENT SADDLE)**



**ALTERNATE  
LONGITUDINAL-WELD LOCATION  
(TYPE A-3 ONLY)**

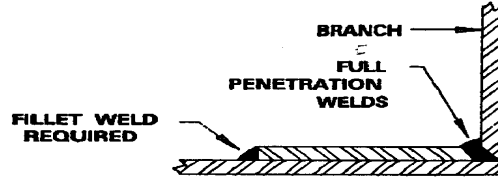
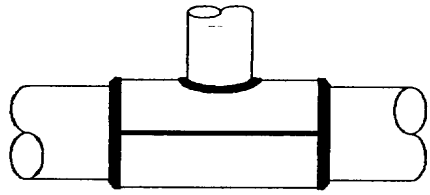


**OPTIONAL  
SLEEVE LONGITUDINAL-WELD DETAILS**

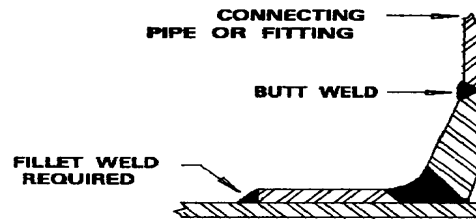
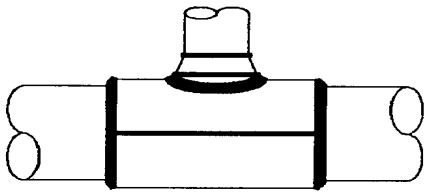
**Figure 3 - Non-pressurized Branch Connections**

# NDO Welding Manual

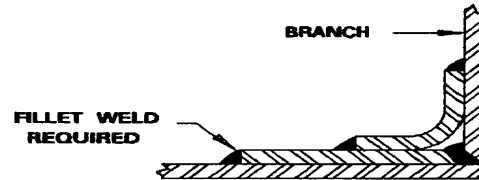
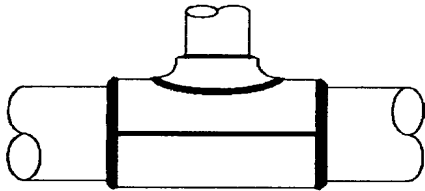
## TYPICAL FULL ENCIRCLEMENT WELDED HOT TAP BRANCH CONNECTIONS PRESSURE CONTAINING



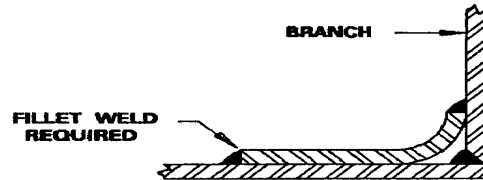
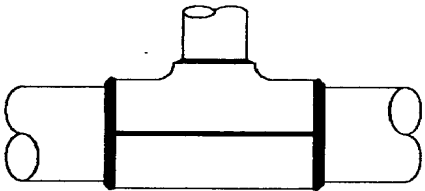
**TYPE B-1: PRESSURE CONTAINING ENCIRCLEMENT SLEEVE WITH ADDED BRANCH SUPPORT**



**TYPE B-2: PRESSURE CONTAINING ENCIRCLEMENT SLEEVE WITH ADDED BRANCH OUTLET FITTING**



**TYPE B-3: PRESSURE CONTAINING ENCIRCLEMENT SLEEVE WITH ADDED BRANCH SUPPORT**



**TYPE B-4: PRESSURE CONTAINING ENCIRCLEMENT SLEEVE WITH INTEGRAL BRANCH SUPPORT (ENCIRCLEMENT SADDLE)**

**Figure 4 - Full Encirclement Pressurized Branch Connections**

## **APPENDIX A INDUSTRY REFERENCES**

The following industry code standards or guides are listed for references and are to be used as applicable.

**Note:** All of these standards are incorporated by reference in 49 CFR Part 192.7.

- A. American Gas Association (AGA):
  - 1. AGA Pipeline Research Committee, Project PR-3-805, "A Modified Criterion for Evaluating the Remaining Strength of Corroded Pipe" (December 22, 1989).
  
- B. American Petroleum Institute (API):
  - 1. API Specification 5L "Specification for Line Pipe" (44<sup>th</sup> edition and errata 2009).
  - 2. API Recommended Practice 5L1 "Recommended Practice for Railroad Transportation of Line Pipe" (7<sup>th</sup> edition, 2002).
  - 3. API Specification 6D "Specification for Pipeline Valves (Gate, Plug, Ball, and Check Valves)" (23<sup>rd</sup> edition, 2009)
  - 4. API Standard 1104 "Welding of Pipelines and Related Facilities" (20<sup>th</sup> edition, 2007 including Errata 2009)
  
- C. The American Society for Testing and Materials (ASTM):
  - 1. ASTM Designation: A 53/A53M-04a (2007) "Standard Specification for Pipe, Steel, Black and Hot-Dipped, Zinc-Coated Welded and Seamless"
  - 2. ASTM Designation: A106/A106M-04b (2008) "Standard Specification for Seamless Carbon Steel Pipe for High-Temperature Service"
  - 3. ASTM Designation: A333/A333M-05 (2005)"Standard Specification for Seamless and Welded Steel Pipe for Low-Temperature Service"
  - 4. ASTM Designation: A372/A372M-03 (2003) "Standard Specification for Carbon and Alloy Steel Forgings for Thin-Walled Pressure Vessels"
  - 5. ASTM Designation: A381-96 (1996, re-approved 2005) "Standard Specification for Metal-Arc-Welded Steel Pipe for Use with High-Pressure Transmission Systems"
  - 6. ASTM Designation: A671-04 (2006) "Standard Specification for Electric-Fusion-Welded Steel Pipe for Atmospheric and Lower Temperatures"
  - 7. ASTM Designation: A672-96 (re-approved 2008) "Standard Specification for Electric-Fusion-Welded Steel Pipe for High-Pressure Service at Moderate Temperatures"
  - 8. ASTM Designation: A691-98 (re-approved 2007) "Standard Specification for Carbon and Alloy Steel Pipe, Electric-Fusion-Welded for High-Pressure Service at High Temperatures"
  
- D. The American Society of Mechanical Engineers (ASME):
  - 1. ASME/ANSI B16.1 "Cast Iron Pipe Flanges and Flanged Fittings" (2005).
  - 2. ASME/ANSI B16.5 "Pipe Flanges and Flanged Fittings" (October 2009)
  - 3. ASME/ANSI B31G "Manual for Determining the Remaining Strength of Corroded Pipelines" (1991, Reaffirmed 2009).
  - 4. ASME/ANSI B31.8-2003 "Gas Transmission and Distribution Piping Systems" (February 2007).
  - 5. ASME/ANSI B31.8S-2004 "Supplement to B31.8 on Managing System Integrity of Gas

Pipelines”

6. ASME Boiler and Pressure Vessel Code, Section I "Power Boilers" (2004 edition with addenda through July 1, 2007).
  7. ASME Boiler and Pressure Vessel Code, Section VIII, Division 1 "Pressure Vessels" (2004 edition with addenda through July 12, 2007).
  8. ASME Boiler and Pressure Vessel Code, Section VIII, Division 2 "Pressure Vessels: Alternative Rules" (2007).
  9. ASME Boiler and Pressure Vessel Code, Section IX "Welding and Brazing Qualifications" (2004 edition, with addenda through July 1, 2007).
- E. Manufacturers Standardization Society of the Valve and Fittings Industry, Inc. (MSS):
1. MSS SP-44-96 "Steel Pipe Line Flanges" (1996, reaffirmed 2001)
- F. National Fire Protection Association (NFPA):
1. NFPA 30 "Flammable and Combustible Liquids Code" (2008).
  2. ANSI/NFPA 58 "Standard for the Storage and Handling of Liquefied Petroleum Gases" (2008).
  3. ANSI/NFPA 59 "Standard for the Storage and Handling of Liquefied Petroleum Gases at Utility Gas Plants" (2008).
  4. ANSI/NFPA 70 "National Electrical Code" (2008).

## APPENDIX B

| WPS                                | Process                                   | Pipe Grades       | Diameters                             | Wall Thicknesses                                    |
|------------------------------------|---|-------------------|---------------------------------------|---|
| GMAW B-X65                         | Fixed GMAW Fillet Welds, All Groove Welds | Grade B - X65     | All Diameters                         | 0.188" - 0.750" and Less than 0.188 for X42 or less |
| OAW 1 Pass                         | OAW Groove Welds                          | Grade B           | All Diameter less than or equal to 6" | Maximum wall thickness is 0.191"                    |
| OAW 2 Pass                         | OAW Groove Welds                          | Grades B          | All Diameter less than or equal to 6" | Maximum wall thickness is 0.191"                    |
| SAW Groove                         | Rolled SAW Groove Welds                   | Grades B – X65    | All Diameters                         | 0.188" – 0.750"                                     |
| SMAW B-X52 Fillet less than 0.188" | Fixed SMAW Fillet Welds                   | Grades B-X52      | All Diameters                         | Less than 0.188"                                    |
| SMAW B-X52 Groove LT 0.188"        | Fixed SMAW Groove Welds                   | Grades B-X52      | All Diameters                         | Less than 0.188"                                    |
| SMAW B--X70 Fillet 0.188"-0.750"   | Fixed SMAW Fillet Welds                   | Grades B - X70    | All Diameters                         | 0.188" - 0.750"                                     |
| SMAW Fixed Groove 0.188"-0.750"    | Fixed SMAW Groove Welds                   | Grades B-X70      | All Diameters                         | 0.188" - 0.750"                                     |
| SMAW In-Service                    | Fixed SMAW In-Service Welds               | All Pipe Grades   | All Diameters                         | All Wall Thicknesses                                |
| SMAW Wall Thickness over 0.750"    | Fixed SMAW Groove Welds                   | Grade X56 or less | All Diameters                         | Greater than 0.750"                                 |
| Repairs of GMAW welds Using SMAW   | Fixed                                     | 65000 psi or less | All Diameters                         | 0,750" or less                                      |
| Repairs of SAW welds Using GMAW    | Fixed                                     | 65000 psi or less | All Diameters                         | 0.750" or less                                      |
| Repairs of SAW Welds Using SMAW    | Fixed                                     | 65000 psi or less | All Diameters                         | 0.750" or less                                      |
| SMAW Double Repair Grade B – X42   | Fixed SMAW Welds                          | Grade X42 or less | All Diameters                         | 0.188" - 0.750"                                     |
| SMAW X65 Double Repair             | Fixed SMAW Welds                          | Grade X65         | All Diameters                         | 0.188" – 0.750"                                     |

| Fitting Material Steel Grades for Welding |  |                  |                     |   |   |
|---|--|------------------|---------------------|---|---|
| MANUFACTURER                              | MODEL  | SIZE             | Pressure rating     | MATERIAL  | SMYS  |
| TDW                                       | SHORTSTOPP®<br>Weld Fitting                            | 1-1/4" – 3"      | ANSI 150,<br>285psi | ASTM A 106 Gr B<br>pipe   | 35000   |
| TDW                                       |  | 4" and<br>larger | ANSI 150,<br>285psi | ASTM A106-<br>Grade B Pipe and<br>ASTM A105 forged<br>steel or ASTM<br>A234 Grade WPB | A106 and A234 - 35000<br>A105 forged - 30000            |
| TDW                                       | SHORTSTOPP®<br>300D Split Tee                          | 2"/3"            | ANSI 300,<br>740psi | ASTM A234 GR<br>WPB and A106 GR<br>B  | 35000   |
| TDW                                       |  | 4" and<br>Larger | ANSI 300,<br>740psi | ASTM A537 Cl 1<br>and A105 Flanges  | A105 forged - 30000<br>A537 Cl - 50000                  |
| TDW                                       | SHORTSTOPP®<br>3-WAY™ Tee                              | 1-1/4" – 3"      | ANSI 150,<br>285psi | ASTM A105<br>FORGED STEEL;<br>ASTM A106 Gr B<br>SMLS Outlet                           | A105 forged - 30000<br>A106 GR B -35000                 |
| TDW                                       |  | 4" and<br>larger | ANSI 150,<br>285psi | ASTM A105 Forged<br>Steel or ASTM<br>A519; A106 Gr B<br>SMLS Outlet                   | A105 forged - 30000<br>A106 GR B -35000<br>A519 - 48300 |
| TDW                                       | SHORTSTOPP®<br>Flat-Bottom<br>Tee                      | 1" - 1-<br>1/2"  | ANSI 150,<br>285psi | ASTM A105 and<br>A106 Gr B  | A105 forged - 30000<br>A106 GR B -35000                 |
| TDW                                       |  | 2"               |                     | ASTM A105<br>Forging  | A105 forged - 30000                                     |
| TDW                                       |  | 3"               |                     | ASTM A234 Gr B  | 35000   |
| TDW                                       |  | 4"-8"            |                     | ASTM A105/A234<br>Gr B  | A105 forged - 30000<br>A234 - 35000                     |
| TDW                                       |  | 10" & 12"        |                     | ASTM A106 Gr<br>B/A105 Forging  | A105 forged - 30000<br>A106 GR B -35000                 |
| TDW                                       | SHORTSTOPP®<br>300D Full<br>Encirclement<br>3-WAY™ Tee | 2"-3"            | ANSI 300,<br>740psi | ASTM A105<br>Forging and ASTM<br>A234 Gr WPB  | A105 forged - 30000<br>A234 - 35000                     |
| TDW                                       |  | 4" and<br>larger |                     | ASTM A537 Cl 1  | A537 Cl - 50000   |



Attachment 1

|     |   |                  |                     |   |   |
|-----|---|------------------|---------------------|---|---|
| TDW | SHORTSTOPP®<br>Spherical 3-<br>WAY™ Tee               | 2"-3"            | ANSI 150,<br>285psi | ASTM A516<br>GR70/ASTM A106<br>GR B   | A516 Gr 70 - 38000<br>A106 GR B -35000                                  |
| TDW |   | 4"               |                     | ASTM A106 GR<br>B/A105/A516 GR<br>70  | A105 forged - 30000<br>A106 GR B -35000<br>A516 Gr 70 - 38000           |
| TDW |   | 6"-12"           |                     | ASTM 105 STL/<br>A516 GR 70   | A105 forged - 30000<br>A516 Gr 70 - 38000                               |
| TDW | SHORTSTOPP®<br>300D<br>Spherical 3-<br>WAY™ Tee       | 2" - 12"         | ANSI 300,<br>740psi | Longitudinal<br>Seams ASME A<br>516 grade 70,<br>Outlet ASTM A105<br>grade B  | A105 forged - 30000<br>A516 Gr 70 - 38000                               |
| TDW | SHORTSTOPP®<br>740 Purge &<br>Equalization<br>Fitting | 2"               | ANSI 300,<br>740psi | ASTM A106 GR B<br>SMLS  | A106 GR B -35000  |
| TDW | SHORTSTOPP®<br>Bolt-On<br>Fitting                     | 1-1/4" –<br>3"   | 60psi               | ASTM A 106 Gr B<br>pipe   | A106 GR B -35000  |
| TDW |   | 4" and<br>larger |                     | ASTM A106-<br>Grade B Pipe and<br>ASTM A105 forged<br>steel or ASTM<br>A234 Grade WPB;<br>SLEEVES of ASTM<br>A285 Grade C | A105 forged - 30000<br>A106 GR B -35000<br>A234 - 35000<br>A285 - 30000 |
| TDW | SHORTSTOPP®<br>Bolt-On 3-<br>WAY™ Tee                 | 1-1/4" –<br>3"   | 60psi               | ASTM A105<br>FORGED STEEL   | A105 forged - 30000   |
| TDW |   | 4" and<br>larger |                     | ASTM A105 Forged<br>Steel; or ASTM<br>A519; A106 Gr B<br>SMLS Outlet;<br>SLEEVES of ASTM<br>A285 Grade C                  | A105 forged - 30000<br>A106 GR B -35000<br>A519 - 48300<br>A285 - 30000 |

Attachment 1  
Page 3 of 5

|     |                                |                      |  |   |   |
|-----|--------------------------------|----------------------|--|---|---|
| TDW | M-STOPP™<br>Fitting            | 3"                   | ASNI 150-300-<br>400, 990psi                       | ASTM 516 GR<br>70/ASTM<br>A105/ASTM A106<br>GR B              | A105 forged - 30000<br>A106 GR B -35000<br>A516 Gr 70 - 38000 |
| TDW |                                | 3" 400#              |  | ASTM A537 CL<br>1/ASTM<br>A105/ASTM A106<br>GR B              | A105 forged - 30000<br>A106 GR B -35000<br>A537 Cl - 50000    |
| TDW |                                | 4"-8"                |  | ASTM 537 CLA<br>1/ASTM A105/<br>ASTM A106 GR B                | A105 forged - 30000<br>A106 GR B -35000<br>A537 Cl - 50000    |
| TDW |                                | 8"-150               |  | ASTM A 516 GR<br>70/ASTM A105/<br>ASTM 106 GR B               | A105 forged - 30000<br>A106 GR B -35000<br>A516 Gr 70 - 38000 |
| TDW |                                | 10"&<br>12"-150      |  | ASTM A516 GR<br>70/ASTM<br>A105/ASTM A106<br>GR B             | A105 forged - 30000<br>A106 GR B -35000<br>A516 Gr 70 - 38000 |
| TDW |                                | 10"& 12-<br>300/400  |  | ASTM A537 CL<br>1/ASTM A105/<br>ASTM A106 GR B                | A105 forged - 30000<br>A106 GR B -35000<br>A537 Cl - 50000    |
| TDW |                                | STOPPLE®<br>Fittings |  | 4" and<br>Larger  | ASME Class<br>150-300-600,<br>285psi to<br>1480psi            |
| TDW | STOPPLE®<br>Plus Fittings      | 4" - 20"             | ASME Class<br>150-300-600,<br>285psi to<br>1480psi | Sleeve: ASTM<br>A537 Cl 1 Steel;<br>Flange: ASTM<br>A-105 (N) | A105 forged - 30000<br>A537 Cl - 50000                        |
| TDW | Tapping<br>Fittings            | 2" - 30"             | ASME Class<br>150-300-600,<br>285psi -<br>1480psi  | Sleeve: ASTM<br>A537 Cl 1 Steel;<br>Flange: ASTM<br>A-105 (N) | A105 forged - 30000<br>A537 Cl - 50000                        |
| TDW | THREAD-O-<br>RING™<br>Fittings | 2" and 3"            |  | ASTM A333 Gr B  | 30000   |

Attachment 1

|         |  |          |  |                                 |                                    |
|---------|--|----------|--|---------------------------------|------------------------------------|
| TDW     | THREAD-O-RING™ Flanged Fittings                        | 2"       |  | ASTM A105 N                     | A105 forged - 30000                |
| Dresser | 501 Service Tee  |          |  |                                 | Weld as 30000                      |
| Dresser | 90 Tap-N-Valve Tee                                     |          |  |                                 | Weld as 30000                      |
| Dresser | 110 Reinforcing Sleeve for Welded Joints               |          |  | ASTM A572 Gr 50 or A588         | 50,000                             |
| Dresser | 115 Reinforcing Sleeve for Pipe Repair                 |          |  | To Customer Specification       | NA                                 |
| Dresser | 220 Reinforcing Sleeve for Couplings                   | 2 - 24"  |  | ASTM A572 Gr 50 or A588         | 50,000                             |
| Dresser | 220-S Reinforcing Sleeve for Couplings                 | 3/4 - 2" |  | AISI C1012 or ASTM A513 Gr 1015 | AISI C1012 – 30,000<br>A513 35,000 |
| Mueller | Service Tees   |          |  | ASTM A105                       | 36,000                             |
| Mueller | Service Stop Tees                                      |          |  | ASTM A105                       | 36,000                             |
| Mueller | Curb Stop Tees   |          |  | ASTM A105                       | 36,000                             |
| Mueller | 3/4" - 4" One Piece Low Pressure Line Stopper Fittings |          |  | ASTM A105                       | 36,000                             |
| Mueller | 3/4" - 2 1/2" Two Piece Line Stopper Fittings          |          |  | ASTM A105                       | 36,000                             |

Attachment 1  
Page 5 Of 5

|                               |   |            |  |   |                                    |
|-------------------------------|---|------------|--|---|------------------------------------|
| Mueller                       | 3" - 12" Line Stopper Fittings & Flanged Tees |            |  | ASTM A105                                   | 36,000                             |
| Georg Fischer Central Plastic | Transition Fitting                            | 1/2" - 12" |  | API 5L Grade B                              | 35,000                             |
| Georg Fischer Central Plastic | Transition Fitting                            | 12' - 24"  |  | API 5L Grade B or ASTM A53 Type E Grade A   | API 5L - 35000<br>ASTM A53 - 30000 |
| Continental Industries        | Tees  |            |  | Tee Bodies ASTM A 513 Type 5                | 70,000                             |
|                               |   |            |  | Outlet - ASTM A53 Pipe or 1020 Carbon Steel | 35000                              |

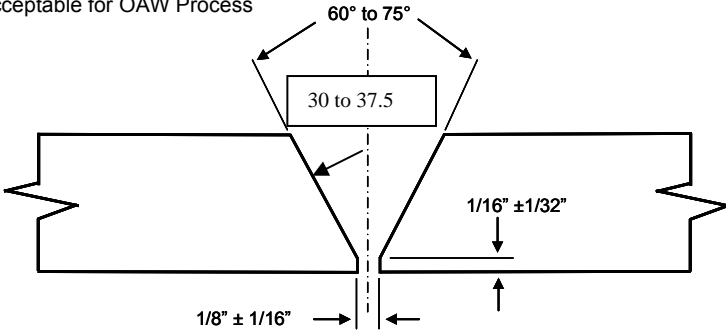
Welding Procedure Specification  
WPS GMAW B-X65

|  |   |  |  |
|--|---|--|--|
| Applicable Codes and Specifications                  | API Standard 1104 20 <sup>th</sup> Edition  | Date: 1/3/2010   | Revision Date: September 19,2011   |
| Supporting PQR                                       | Procedure Qualification Record (PQR):GMAW 1-2010, GMAW 2-2010, GMAW 3-2010, 40-99, 39-99 and 106-04 PQR GMAW X60 Fixed, PQR GMAW X60 ROLLED, PQR GMAW X60 FILLET, PQR GMAW X65 ROLLED, PQR X65 FIXED, PQR X65 FILET   |  |  |
| Process and Method                                   | Gas Metal Arc Welding<br>Semi-automatic   | Shielding Gas – 75% Argon / 25% CO <sub>2</sub><br>Flow Rate Range – 15-50 CFH |  |
| Materials, Diameter, and Wall Thickness              | Materials:<br><input checked="" type="checkbox"/> API 5L X42, Grade B<br><input checked="" type="checkbox"/> API 5L X46, X52, X56, X60<br><input checked="" type="checkbox"/> API 5L X65<br><input type="checkbox"/> API 5L X70   | Diameter:<br>All Diameters   | Wall Thickness:<br><input checked="" type="checkbox"/> Under 0.188 (X42 or less)<br><input checked="" type="checkbox"/> 0.188 through 0.750<br><input type="checkbox"/> Over 0.750 |
| Joint Design   |   |  |  |
| Position of Pipe Axis                                | <input checked="" type="checkbox"/> Flat (1G) <input checked="" type="checkbox"/> Multiple (5G)<br><input checked="" type="checkbox"/> Horizontal (2G) <input checked="" type="checkbox"/> Inclined (6G)<br><input checked="" type="checkbox"/> Vertical (3G) <input checked="" type="checkbox"/> Fixed<br><input checked="" type="checkbox"/> Overhead (4G) <input checked="" type="checkbox"/> Rolled   |  |  |
| Minimum Number of Welders                            |   |  |  |
| Type & Removal of Lineup Clamp                       | Not Required. When Used the recommendation is:<br>External - 50% of root bead must be completed before removal<br>OR<br>Internal - 100% of root bead must be complete before removal  |  |  |
| Preheating: Method, Temperature, Temperature Control | <u>Above 40 °F</u> <u>40 °F and Below</u><br>None Required                                      150 °F minimum<br>For wall thicknesses exceeding 0.500", preheat pipe to 200 °F.<br>Preheat to 250 °F – 350 °F max. for all welding repairs using this procedure.<br>Heat using a gas torch, induction coils, or other approved method. Heat should be used to remove any moisture before welding. Monitor temperature using tempil sticks, contact pyrometer, or infrared gun. |  |  |

Welding Procedure Specification  
WPS GMAW B-X65

|                                   |  |                      |                                |                      |
|-----------------------------------|--|----------------------|--------------------------------|----------------------|
| Post Weld Heat Treatment          | <input type="checkbox"/> Yes <input checked="" type="checkbox"/> No  |                      | Time N/A<br>Temperature N/A °F |                      |
| Cleaning and/or Grinding          | <input checked="" type="checkbox"/> Hand Tools <input checked="" type="checkbox"/> Power Tools   |                      |                                |                      |
| Time Between Passes (mins)        | Root and Hot 5 max. Time Between Hot and First Fill - 10 max when wall thickness exceeds 0.500". All other passes within 15 Minutes when half the groove is not filled. If 15 minutes as exceeded, then the weld shall be preheated to 250 -350 degrees F. If half the groove is filled then time between remaining passes is 72 hours and preheat according to the preheat section in this WPS. |                      |                                |                      |
| Welding Pass                      | Root Bead (RB)   | Hot (H)              | Fills (F)                      | Cap (C)              |
| Welding Process                   | GMAW   | GMAW                 | GMAW                           | GMAW                 |
| Direction of Welding              | Vertical Down  | Vertical Down        | Vertical Down                  | Vertical Down        |
| Polarity                          | DCRP (+)   | DCRP (+)             | DCRP (+)                       | DCRP (+)             |
| Deposition Method                 | Stringer/Weave   | Stringer/Weave       | Stringer/Weave                 | Stringer/Weave       |
| AWS Specification                 | A5.18  | A5.18                | A5.18                          | A5.18                |
| AWS Classification                | gr.B-X60   | ER70S-6              | ER70S-6                        | ER70S-6              |
|                                   | X65  | ER80S-6              | ER80S-6                        | ER80S-6              |
| Electrode Diameter(s)             | 0.035"   | 0.035"               | 0.035"                         | 0.035"               |
| Arc Voltage – Min (preferred) Max | 15 - (18-20) - 24  | 16 - (18-20) - 24    | 16 - (18-20) - 24              | 16 - (18-20) - 24    |
| Amperage – Min (preferred) Max    | 75 - (100-180) - 180   | 75 - (100-180) - 180 | 75 - (100-180) - 180           | 75 - (100-180) - 180 |
| Travel Speed Range (inch/min)     | 3 - 15   | 3 - 15               | 3 - 15                         | 3 - 15               |
| Minimum Number of Passes          | Wall Thickness Range (in)  | Number of Passes     |                                | Number of Cap Passes |
|                                   | < 0.188  | 2                    |                                | 1                    |
|                                   | ≥ 0.188 to 0.250   | 2                    |                                | 1                    |
|                                   | ≥ 0.250 to 0.500   | 3                    |                                | 1                    |
|                                   | ≥ 0.500 through 0.750  | 4                    |                                | 1                    |
| Notes                             | Stripper beads are optional and do not count toward the minimum number of passes.  |                      |                                |                      |
| Optional Electrode                |  |                      |                                |                      |
| Welding Pass                      | RB   | H                    | F                              | C                    |
| AWS Specification                 | A5.28  | A5.28                | A5.28                          | A5.28                |
| AWS Classification                | ER80S-D2   | ER80S-D2             | ER80S-D2                       | ER80S-D2             |
| Diameter                          | 0.035"   | 0.035"               | 0.035"                         | 0.035"               |
| Arc Voltage – Min (preferred) Max | 16 - (18-20) - 24  | 16 - (18-20) - 24    | 16 - (18-20) - 24              | 16 - (18-20) - 24    |
| Amperage – Min (preferred) Max    | 75 - (100-180) - 180   | 75 - (100-180) - 180 | 75 - (100-180) - 180           | 75 - (100-180) - 180 |
| Travel Speed (ipm)                | 3 - 15   | 3 - 15               | 3 - 15                         | 3 - 15               |
| Submittal                         | Author: Robert Lawless   |                      | Title: Gas Standards Engineer  |                      |
|                                   | Company/Organization: NiSource Gas Distribution  |                      |                                | Date: 9/19/2011      |
| Approval                          | Title  | Name                 | Signature                      | Date                 |
|                                   | Gas Standard Engineer  | Robert W. Lawless    |                                | 9/19/2011            |

Welding Procedure Specification  
 WPS OAW 1 PASS

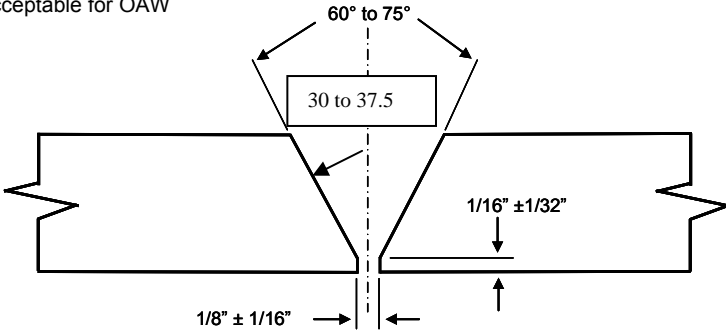
|  |   |   |  |
|--|---|---|--|
| Applicable Codes and Specifications                  | API Standard 1104 20 <sup>th</sup> Edition  | Date: 1/3/2011  | Revision Date:   |
| Supporting PQR                                       | Procedure Qualification Record (PQR):<br>101R001, 101R002, 101R004, 101R005, 101R006, 101R007 and 101R008   |   |  |
| Process and Method                                   | Oxyacetylene Welding<br>Manual 1-Pass Backhand Method   |   |  |
| Materials, Diameter, and Wall Thickness              | Materials:<br><input checked="" type="checkbox"/> Grade B<br><input type="checkbox"/> API 5L X46, X52, X56, X60<br><input type="checkbox"/> API 5L X65<br><input type="checkbox"/> API 5L X70   | Diameter:<br>All Nominal Diameters Less Than or Equal to 6". Maximum Wall Thickness is 0.191" | Wall Thickness:<br><input checked="" type="checkbox"/> Under 0.188<br><input checked="" type="checkbox"/> 0.188 through 0.191<br><input type="checkbox"/> Over 0.750 |
| Joint Design   | No Land is Acceptable for OAW Process<br>  |   |  |
| Position of Pipe Axis                                | <input checked="" type="checkbox"/> Flat (1G) <input checked="" type="checkbox"/> Multiple (5G)<br><input checked="" type="checkbox"/> Horizontal (2G) <input checked="" type="checkbox"/> Inclined (6G)<br><input checked="" type="checkbox"/> Vertical (3G) <input checked="" type="checkbox"/> Fixed<br><input checked="" type="checkbox"/> Overhead (4G) <input checked="" type="checkbox"/> Rolled |   |  |
| Minimum Number of Welders                            | One welder  |   |  |
| Type & Removal of Lineup Clamp                       | External - N/A<br>OR<br>Internal - N/A  |   |  |
| Preheating: Method, Temperature, Temperature Control | Above 40 °F                      40 °F and Below<br>None Required                      150 °F minimum<br><br>Heat using a gas torch, induction coils, or other approved method. Heat should be used to remove any moisture before welding. Monitor temperature using tempil sticks, contact pyrometer, or infrared gun.   |   |  |

**Welding Procedure Specification  
WPS OAW 1 PASS**

|                                     |  |                                |                              |                |
|-------------------------------------|--|--------------------------------|------------------------------|----------------|
| Post Weld Heat Treatment            | <input type="checkbox"/> Yes <input checked="" type="checkbox"/> No                            | Time N/A<br>Temperature N/A °F |                              |                |
| Cleaning and/or Grinding            | <input checked="" type="checkbox"/> Hand Tools <input checked="" type="checkbox"/> Power Tools |                                |                              |                |
| Time Between Passes (mins)          | Root and Hot - Unlimited   |                                |                              |                |
| Wall Thickness                      | Less than 0.188"   | 0.188" – 0.750"                |                              |                |
| Welding Process                     | OAW  | OAW                            |                              |                |
| Direction of Welding                | Vertical Down or Horizontal  | Vertical Down or Horizontal    |                              |                |
| Polarity                            | Nuetral  | Nuetral                        |                              |                |
| AWS Specification                   | A5.2   | A5.2                           |                              |                |
| AWS Classification                  | RG60   | RG60                           |                              |                |
| Maximum Electrode Diameter(s)       | 5/32   | 3/16                           |                              |                |
| Travel Speed Range (inch/min)       | 1-4  | 1-4                            |                              |                |
| Minimum Number of Passes            | Wall Thickness Range (in)  | Number of Passes               | Number of Cap Passes         |                |
|                                     | < 0.188  | 1                              |                              |                |
|                                     | ≥ 0.188 to 0.250   | 1                              |                              |                |
|                                     | ≥ 0.250 to 0.500   | 1                              |                              |                |
|                                     | ≥ 0.500 through 0.750  | 1                              |                              |                |
|                                     | > .750   | N/A                            |                              |                |
| <b>Optional Electrode Diameters</b> |  |                                |                              |                |
| AWS Specification                   | A5.2   | A5.2                           |                              |                |
| AWS Classification                  | RG60   | RG60                           |                              |                |
| Diameter                            | 3/32   | 1/8                            |                              |                |
| Travel Speed (ipm)                  | 1-4  | 1-4                            |                              |                |
| Submittal                           | Author: Robert W. Lawless  |                                | Title: Gas Standard Engineer |                |
|                                     | Company/Organization: NiSource Gas Distribution  |                                |                              | Date: 1/3/2011 |
| Approval                            | Title  | Name                           | Signature                    | Date           |
|                                     | Gas Standard Engineer  | Robert W. Lawless              |                              | 01/03/2011     |
|                                     |  |                                |                              |                |
|                                     |  |                                |                              |                |



Welding Procedure Specification  
 WPS OAW 2 PASS

|  |   |   |  |
|--|---|---|--|
| Applicable Codes and Specifications                  | API Standard 1104 20 <sup>th</sup> Edition  | Date: 1/3/2011  | Revision Date:   |
| Supporting PQR                                       | Procedure Qualification Record (PQR):<br>102R001, 102R002, 102R003, 102R005, 102R006 and 102R008  |   |  |
| Process and Method                                   | Oxyacetylene Welding<br>Manual 2-Pass Backhand/Forehand Method  |   |  |
| Materials, Diameter, and Wall Thickness              | Materials:<br><input checked="" type="checkbox"/> Grade B<br><input type="checkbox"/> API 5L X46, X52, X56, X60<br><input type="checkbox"/> API 5L X65<br><input type="checkbox"/> API 5L X70   | Diameter:<br>All Nominal Diameters Less Than or Equal to 6". Maximum Wall Thickness is 0.191" | Wall Thickness:<br><input checked="" type="checkbox"/> Under 0.188<br><input checked="" type="checkbox"/> 0.188 through 0.191<br><input type="checkbox"/> Over 0.750 |
| Joint Design   | No Land is Acceptable for OAW<br>  |   |  |
| Position of Pipe Axis                                | <input checked="" type="checkbox"/> Flat (1G) <input checked="" type="checkbox"/> Multiple (5G)<br><input checked="" type="checkbox"/> Horizontal (2G) <input checked="" type="checkbox"/> Inclined (6G)<br><input checked="" type="checkbox"/> Vertical (3G) <input checked="" type="checkbox"/> Fixed<br><input checked="" type="checkbox"/> Overhead (4G) <input checked="" type="checkbox"/> Rolled |   |  |
| Minimum Number of Welders                            | One welder  |   |  |
| Type & Removal of Lineup Clamp                       | External - N/A<br>OR<br>Internal - N/A  |   |  |
| Preheating: Method, Temperature, Temperature Control | Above 40 °F                      40 °F and Below<br>None Required                      150 °F minimum<br><br>Heat using a gas torch, induction coils, or other approved method. Heat should be used to remove any moisture before welding. Monitor temperature using tempil sticks, contact pyrometer, or infrared gun.   |   |  |

**Welding Procedure Specification  
WPS OAW 2 PASS**

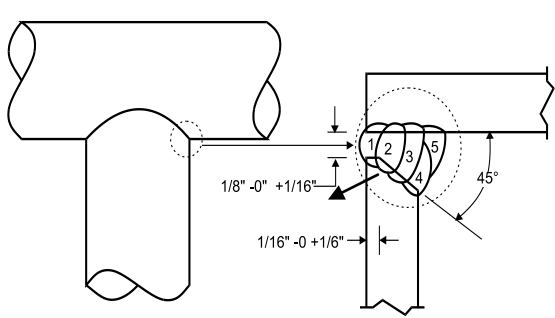
|                               |  |  |  |  |
|-------------------------------|--|--|--|--|
| Post Weld Heat Treatment      | <input type="checkbox"/> Yes <input checked="" type="checkbox"/> No                            | Time N/A<br>Temperature N/A °F                 |  |  |
| Cleaning and/or Grinding      | <input checked="" type="checkbox"/> Hand Tools <input checked="" type="checkbox"/> Power Tools |  |  |  |
| Time Between Passes (mins)    | Root and Hot - Unlimited   |  |  |  |
| Wall Thickness                | Less than 0.188"   |  | 0.188" – 0.750"                                |  |
| Welding Pass                  | Root Bead (RB)   | Cover  | Root Bead (RB)                                 | Cover  |
| Welding Process               | OAW  | OAW  | OAW  | OAW  |
| Direction of Welding          | Vertical Up,<br>Vertical Down or<br>Horizontal   | Vertical Up,<br>Vertical Down or<br>Horizontal | Vertical Up,<br>Vertical Down or<br>Horizontal | Vertical Up,<br>Vertical Down or<br>Horizontal |
| Polarity                      | Nuetral  | Nuetral  | Nuetral  | Nuetral  |
| AWS Specification             | A5.2   | A5.2   | A5.2   | A5.2   |
| AWS Classification            | RG60   | RG60   | RG60   | RG60   |
| Maximum Electrode Diameter(s) | 5/32   | 5/32   | 3/16   | 3/16   |
| Travel Speed Range (inch/min) | 1-4  | 0.5-2  | 1-4  | 0.5-2  |
| Minimum Number of Passes      | Wall Thickness Range (in)  | Number of Passes                               | Number of Cap Passes                           |  |
|                               | < 0.188  | 2  |  |  |
|                               | ≥ 0.188 to 0.250   | 2  |  |  |
|                               | ≥ 0.250 to 0.500   | 2  |  |  |
|                               | ≥ 0.500 through 0.750  | 2  |  |  |
|                               | > .750   | N/A  |  |  |
| Optional Electrode Diameters  |  |  |  |  |
| Welding Pass                  | Root Bead (RB)   | Root Bead (RB)                                 | Cover  | Cover  |
| AWS Specification             | A5.2   | A5.2   | A5.2   | A5.2   |
| AWS Classification            | RG60   | RG60   | RG60   | RG60   |
| Diameter                      | 3/32   | 1/8  | 3/32   | 1/8  |
| Travel Speed (ipm)            | 1-4  | 1-4  | 0.5-2  | 0.5-2  |
| Submittal                     | Author: Robert W. Lawless  |  | Title: Gas Standards Engineer                  |  |
|                               | Company/Organization: NiSource Gas Distribution  |  |  | Date: 01/03/2011                               |
| Approval                      | Title  | Name   | Signature                                      | Date   |
|                               | Gas Standards Engineer   | Robert W. Lawless                              |  | 01/03/2011                                     |
|                               |  |  |  |  |
|                               |  |  |  |  |



**Welding Procedure Specification  
WPS SAW Groove**

|                                     |  |                     |                                |                     |
|-------------------------------------|--|---------------------|--------------------------------|---------------------|
| Post Weld Heat Treatment            | <input type="checkbox"/> Yes <input checked="" type="checkbox"/> No  |                     | Time N/A<br>Temperature N/A °F |                     |
| Cleaning and/or Grinding            | <input checked="" type="checkbox"/> Hand Tools <input checked="" type="checkbox"/> Power Tools   |                     |                                |                     |
| Time Between Passes (mins)          | Root and Hot 5 max. Time Between Hot and First Fill - 10 max when wall thickness exceeds 0.500". All other passes within 15 Minutes when half the groove is not filled. If 15 minutes as exceeded, then the weld shall be preheated to 250 -350 degrees F. If half the groove is filled then time between remaining passes is 72 hours and preheat according to the preheat section in this WPS. |                     |                                |                     |
| Welding Pass                        | Root Bead (RB)   | Hot (H)             | Fills (F)                      | Cap (C)             |
| Welding Process                     | GMAW   | SAW                 | SAW                            | SAW                 |
| Direction of Welding                | Vertical Down  | Flat                | Flat                           | Flat                |
| Polarity                            | DCRP (+)   | DCRP (+)            | DCRP (+)                       | DCRP (+)            |
| Deposition Method                   | Stringer/Weave   | Stringer            | Stringer                       | Stringer            |
| AWS Specification                   | A5.18  | A5.17               | A5.17                          | A5.17               |
| AWS Classification                  | ER70S  | F7AO-EL12           | F7AO-EL12                      | F7AO-EL12           |
| Electrode Diameter(s)               | 0.035"   | 0.1875"             | 0.1875"                        | 0.1875"             |
| Arc Voltage – Min (preferred) Max   | 16 - (22-28) - 34  | 28 - (30-34) - 38   | 28 - (30-34) - 38              | 28 - (30-34) - 38   |
| Amperage – Min (preferred) Max      | 90 -(130-170)- 200   | 210 -(290-390)- 450 | 210 -(290-390)- 450            | 210 -(290-390)- 450 |
| Travel Speed Range (inch/min)       | 3 - 18   | 4 - 18              | 4 - 18                         | 4 - 18              |
| Minimum number of Passes            | Wall Thickness Range (in)  | Number of passes    | Number of Cap Passes           |                     |
|                                     | < 0.188  | 2                   | 1                              |                     |
|                                     | ≥ 0.188 to 0.250   | 2                   | 1                              |                     |
|                                     | ≥ 0.250 to 0.500   | 3                   | 1                              |                     |
|                                     | ≥ 0.500 through 0.750  | 4                   | 1                              |                     |
|                                     | > .750   | 5                   | 2                              |                     |
| Notes                               | Stripper beads are optional and do not count toward the minimum number of passes.  |                     |                                |                     |
| <b>Optional Electrode Diameters</b> |  |                     |                                |                     |
| Welding Pass Diameter               | RB, H  | H, F, C             | H, F, C                        | F, C                |
| Arc Voltage – Min (preferred) Max   |  |                     |                                |                     |
| Amperage – Min (preferred) Max      |  |                     |                                |                     |
| Travel Speed (ipm)                  |  |                     |                                |                     |
| Submittal                           | Author: Robert W. Lawless  |                     | Title: Gas Standards Engineer  |                     |
|                                     | Company/Organization: Nisource Distribution  |                     |                                | Date: 08/16/2012    |
| Approval                            | Title  | Name                | Date                           |                     |
|                                     | Gas Standards Engineer   | Robert W. Lawless   | 08/16/2012                     |                     |

**Welding Procedure Specification**  
**WPS SMAW (B-X52) Fillet Less Than .188**

|  |   |                            |   |
|--|---|----------------------------|---|
| Applicable Codes and Specifications                  | API Standard 1104 20 <sup>th</sup> Edition  | Date: 2/10/2011            | Revision Date:  |
| Supporting PQR                                       | Procedure Qualification Record (PQR): SMAW B-X52 Fillet LT 188, X52 LT 188 Fillets  |                            |   |
| Process and Method                                   | Shielded Metal Arc Welding<br>Manual  |                            |   |
| Materials, Diameter, and Wall Thickness              | Materials:<br><input checked="" type="checkbox"/> API 5L X42, Grade B<br><input checked="" type="checkbox"/> API 5L X46, X52<br><input type="checkbox"/> API 5L X65<br><input type="checkbox"/> API 5L X70  | Diameter:<br>All Diameters | Wall Thickness:<br><input checked="" type="checkbox"/> Under 0.188<br><input type="checkbox"/> 0.188 through 0.750<br><input type="checkbox"/> Over 0.750 |
| Joint Design Butt and Fillet                         |   |                            |   |
| Position of Pipe Axis                                | <input checked="" type="checkbox"/> Flat (1G) <input checked="" type="checkbox"/> Multiple (5G)<br><input checked="" type="checkbox"/> Horizontal (2G) <input checked="" type="checkbox"/> Inclined (6G)<br><input checked="" type="checkbox"/> Vertical (3G) <input checked="" type="checkbox"/> Fixed<br><input checked="" type="checkbox"/> Overhead (4G) <input type="checkbox"/> Rolled  |                            |   |
| Minimum Number of Welders                            | One welder for OD < 16" NPS, two welders required for OD ≥ 16" NPS.   |                            |   |
| Type & Removal of Lineup Clamp                       | External - N/A<br>OR<br>Internal - N/A  |                            |   |
| Preheating: Method, Temperature, Temperature Control | <u>Above 40 °F</u> <u>40 °F and Below</u><br>None Required                                      150 °F minimum<br>For wall thicknesses exceeding 0.500", preheat pipe to 200 °F.<br>Preheat to 250 °F – 350 °F max. for all welding repairs using this procedure.<br>Heat using a gas torch, induction coils, or other approved method. Heat should be used to remove any moisture before welding. Monitor temperature using tempil sticks, contact pyrometer, or infrared gun. |                            |   |

**Welding Procedure Specification  
WPS SMAW (B-X52) Fillet Less Than .188**

|  |   |                                |                               |                         |
|--|---|--------------------------------|-------------------------------|-------------------------|
| Post Weld Heat Treatment   | <input type="checkbox"/> Yes <input checked="" type="checkbox"/> No   | Time N/A<br>Temperature N/A °F |                               |                         |
| Cleaning and/or Grinding   | <input checked="" type="checkbox"/> Hand Tools <input checked="" type="checkbox"/> Power Tools  |                                |                               |                         |
| Time Between Passes (mins)   | Root and Hot 5 max. Time Between Hot and First Fill - 10 max when wall thickness exceeds 0.500". All other passes within 10 minutes. If 10 minutes is exceeded, then the weld shall be preheated to 250-350 degree F. |                                |                               |                         |
| Welding Pass   | Root Bead (RB)  | Hot (H)                        | Fills (F)                     | Cap (C)                 |
| Welding Process  | SMAW  | SMAW                           | SMAW                          | SMAW                    |
| Direction of Welding   | Downhill and Horizontal   | Downhill and Horizontal        | Downhill or Horizontal        | Downhill and Horizontal |
| Polarity   | DCRP (+)  | DCRP (+)                       | DCRP (+)                      | DCRP (+)                |
| Deposition Method  | Stringer  | Stringer                       | Stringer/Weave                | Stringer/Weave          |
| AWS Specification  | A5.1  | A5.1                           | A5.1                          | A5.1                    |
| AWS Classification   | E6010   | E6010                          | E6010                         | E6010                   |
| Electrode Diameter(s)  | 1/8   | 5/32                           | 5/32                          | 5/32                    |
| Arc Voltage – Min (preferred) Max  | 18 - (20-25) - 35   | 18 - (22-28) - 34              | 18 - (22-28) - 34             | 18 - (22-28) - 34       |
| Amperage – Min (preferred) Max   | 80 - (90-120) - 190   | 90 -(130-170)- 200             | 90 -(130-170)- 200            | 90 -(130-170)- 200      |
| Travel Speed Range (inch/min)  | 3-15  | 3-18                           | 3-18                          | 3-18                    |
| Minimum Number of Passes   | Wall Thickness Range (in)   | Number of Passes Includes Cap  |                               | Number of Cap Passes    |
|  | < 0.188   | 3                              |                               | 1                       |
|  |   |                                |                               |                         |
|  |   |                                |                               |                         |
| Notes  | Stripper beads are optional and do not count toward the minimum number of passes.   |                                |                               |                         |
| Optional Electrode Diameters   |   |                                |                               |                         |
| E7010 Electrode AWS Specification A5.5 may be substituted for any single or multiple passes. |   |                                |                               |                         |
| Welding Pass   | RB, H   | H, F, C                        | H, F, C                       | F, C                    |
| Diameter   | 3/32  | 1/8                            | 5/32                          | 3/16                    |
| Arc Voltage – Min (preferred) Max  | 18 - (20-25) - 35   | 18 - (20-25) - 35              | 18 - (22-28) - 34             | 18 - (22-28) - 34       |
| Amperage – Min (preferred) Max   | 40 - (50-80) - 190  | 50 - (90-120) - 190            | 90 - (130-160) - 200          | 110 - (160-200) -225    |
| Travel Speed (ipm)   | 3 - 18  | 3 - 18                         | 3 - 18                        | 3 - 18                  |
| Submittal  | Author: Robert W. Lawless   |                                | Title: Gas Standards Engineer |                         |
|  | Company/Organization: NiSource Gas Distribution   |                                |                               | Date: 2/10/2011         |
| Approval   | Title   | Name                           |                               | Date                    |
|  | Gas Standard Engineer   | Robert W. Lawless              |                               | 2/10/2011               |
|  |   |                                |                               |                         |

**Welding Procedure Specification**  
**WPS SMAW B-X52 Groove Less Than 0.188"**

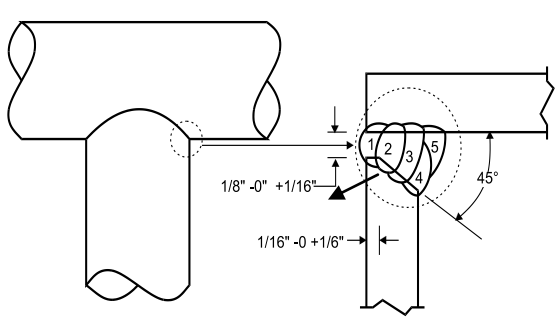
|  |   |                 |  |
|--|---|-----------------|--|
| Applicable Codes and Specifications                  | API Standard 1104 20 <sup>th</sup> Edition  | Date: 2/10/2011 | Revision Date:   |
| Supporting PQR                                       | Procedure Qualification Record (PQR): SMAW X42-X52 Fixed Groove LT 188  |                 |  |
| Process and Method                                   | Shielded Metal Arc Welding<br>Manual  |                 |  |
| Materials, Diameter, and Wall Thickness              | Materials:  | Diameter:       | Wall Thickness:  |
|  | <input checked="" type="checkbox"/> API 5L X42, Grade B<br><input checked="" type="checkbox"/> API 5L X46, X52<br><input type="checkbox"/> API 5L X65<br><input type="checkbox"/> API 5L X70  | All Diameters   | <input checked="" type="checkbox"/> Under 0.188<br><input type="checkbox"/> 0.188 through 0.750<br><input type="checkbox"/> Over 0.750 |
| Joint Design Butt and Fillet                         |   |                 |  |
| Position of Pipe Axis                                | <input checked="" type="checkbox"/> Flat (1G) <input checked="" type="checkbox"/> Multiple (5G)<br><input checked="" type="checkbox"/> Horizontal (2G) <input checked="" type="checkbox"/> Inclined (6G)<br><input checked="" type="checkbox"/> Vertical (3G) <input checked="" type="checkbox"/> Fixed<br><input checked="" type="checkbox"/> Overhead (4G) <input type="checkbox"/> Rolled  |                 |  |
| Minimum Number of Welders                            | One welder for OD < 16" NPS, two welders required for OD ≥ 16" NPS.   |                 |  |
| Type & Removal of Lineup Clamp                       | None required. When used the requirements are<br>External - 50% of root bead must be completed before removal<br>OR<br>Internal - 100% of root bead must be complete before removal   |                 |  |
| Preheating: Method, Temperature, Temperature Control | Above 40 °F                      40 °F and Below<br>None Required                      150 °F minimum<br>For wall thicknesses exceeding 0.500", preheat pipe to 200 °F.<br>Preheat to 250 °F – 350 °F max. for all welding repairs using this procedure.<br>Heat using a gas torch, induction coils, or other approved method. Heat should be used to remove any moisture before welding. Monitor temperature using tempil sticks, contact pyrometer, or infrared gun. Wrought iron pipe will be preheated to 250 °F. |                 |  |

**Welding Procedure Specification  
WPS SMAW B-X52 Groove Less Than 0.188"**

|  |  |  |  |  |
|--|--|--|--|--|
| Post Weld Heat Treatment   | <input type="checkbox"/> Yes <input checked="" type="checkbox"/> No  | Time N/A<br>Temperature N/A °F           |  |  |
| Cleaning and/or Grinding   | <input checked="" type="checkbox"/> Hand Tools <input checked="" type="checkbox"/> Power Tools   |  |  |  |
| Time Between Passes (mins)   | Root and Hot 5 max. Time Between Hot and First Fill - 10 max when wall thickness exceeds 0.500". All other passes within 15 Minutes when half the groove is not filled. If 15 minutes as exceeded, then the weld shall be preheated to 250 -350 degrees F. If half the groove is filled then time between remaining passes is 72 hours and preheat according to the preheat section in this WPS. |  |  |  |
| Welding Pass   | Root Bead (RB)   | Hot (H)                                  | Fills (F)                                | Cap (C)                                  |
| Welding Process  | SMAW   | SMAW                                     | SMAW                                     | SMAW                                     |
| Direction of Welding   | Vertical Down  | Vertical Down                            | Vertical Down                            | Vertical Down                            |
| Polarity   | DCRP (+)   | DCRP (+)                                 | DCRP (+)                                 | DCRP (+)                                 |
| Deposition Method  | Stringer   | Stringer                                 | Stringer/Weave                           | Stringer/Weave                           |
| AWS Specification  | A5.1   | Grade B-X42 A5.1<br>Grade X46-X52 A5.5   | Grade B-X42 A5.1<br>Grade X46-X52 A5.5   | Grade B-X42 A5.1<br>Grade X46-X52 A5.5   |
| AWS Classification   | E6010  | Grade B-X42 E6010<br>Grade X46-X52 E7010 | Grade B-X42 E6010<br>Grade X46-X52 E7010 | Grade B-X42 E6010<br>Grade X46-X52 E7010 |
| Electrode Diameter(s)  | 1/8  | 5/32                                     | 5/32                                     | 5/32                                     |
| Arc Voltage – Min (preferred) Max  | 18 - (20-25) - 35  | 18 - (22-28) - 34                        | 18 - (22-28) - 34                        | 18 - (22-28) - 34                        |
| Amperage – Min (preferred) Max   | 80 - (90-120) - 190  | 90 -(130-170)- 200                       | 90 -(130-170)- 200                       | 90 -(130-170)- 200                       |
| Travel Speed Range (inch/min)  | 3 - 15   | 3 - 18                                   | 3 - 18                                   | 3 - 18                                   |
| Minimum Number of Passes   | Wall Thickness Range (in)  | Number of Passes                         |  | Number of Cap Passes                     |
|  | < 0.188  | 2  |  | 1  |
|  |  |  |  |  |
|  |  |  |  |  |
| Notes  | Stripper beads are optional and do not count toward the minimum number of passes.  |  |  |  |
| Optional Electrode Diameters   |  |  |  |  |
| E7010 Electrode AWS Specification A5.5 may be substituted for any single or multiple passes. |  |  |  |  |
| Welding Pass   | RB, H  | RB,H, F, C                               | RB,H, F, C                               | F, C                                     |
| Diameter   | 3/32   | 1/8                                      | 5/32                                     | 3/16                                     |
| Arc Voltage – Min (preferred) Max  | 18 - (20-25) - 35  | 18 - (20-25) - 35                        | 18 - (22-28) - 34                        | 18 - (22-28) - 34                        |
| Amperage – Min (preferred) Max   | 40 - (50-80) - 190   | 50 - (90-120) - 190                      | 90 - (130-160) - 200                     | 110 - (160-200) -225                     |
| Travel Speed (ipm)   | 3 - 18   | 3 - 18                                   | 3 - 18                                   | 3 - 18                                   |
| Submittal  | Author: Robert W. Lawless  |  | Title: Gas Standards Engineer            |  |
|  | Company/Organization: NiSource Gas Distribution  |  |  | Date:2/10/2011                           |
| Approval   | Title  | Name                                     |  | Date                                     |
|  | Gas Standard Engineer  | Robert W. Lawless                        |  | 2/10/2011                                |



**Welding Procedure Specification**  
**WPS SMAW B-X70 Fillet 0.188"-0.750"**

|  |  |                                |   |
|--|--|--------------------------------|---|
| Applicable Codes and Specifications                  | API Standard 1104 20 <sup>th</sup> Edition   | Date: 1/3/2011                 | Revision Date: 02/13/2013   |
| Supporting PQR                                       | Procedure Qualification Record (PQR): Sc/122-BR, SMAW -5-2010, PQR SMAW X65-FILLET, PQR SMAW X70 FILLET, PQR X65 Fillet 7010   |                                |   |
|  | Shielded Metal Arc Welding<br><br>Manual   |                                |   |
| Materials, Diameter, and Wall Thickness              | Materials:<br><input checked="" type="checkbox"/> API 5L X42, Grade B<br><input checked="" type="checkbox"/> API 5L X46, X52, X56, X60<br><input checked="" type="checkbox"/> API 5L X65<br><input checked="" type="checkbox"/> API 5L X70   | Diameter:<br><br>All Diameters | Wall Thickness:<br><input type="checkbox"/> Under 0.188<br><input checked="" type="checkbox"/> 0.188 through 0.750<br><input type="checkbox"/> Over 0.750 |
| Joint Design Butt and Fillet                         |    |                                |   |
| Position of Pipe Axis                                | <input checked="" type="checkbox"/> Flat (1G) <input checked="" type="checkbox"/> Multiple (5G)<br><input checked="" type="checkbox"/> Horizontal (2G) <input checked="" type="checkbox"/> Inclined (6G)<br><input checked="" type="checkbox"/> Vertical (3G) <input checked="" type="checkbox"/> Fixed<br><input checked="" type="checkbox"/> Overhead (4G) <input type="checkbox"/> Rolled   |                                |   |
| Minimum Number of Welders                            | One welder for OD < 16" NPS, two welders required for OD ≥ 16" NPS.  |                                |   |
| Type & Removal of Lineup Clamp                       | External - N/A<br>OR<br>Internal - N/A   |                                |   |
| Preheating: Method, Temperature, Temperature Control | <u>Above 40 °F</u> <u>40 °F and Below</u><br>None Required                                      150 °F minimum<br>For wall thicknesses exceeding 0.500", preheat pipe to 200 °F.<br>Preheat to 250 °F – 350 °F max. for all welding repairs using this procedure.<br>Heat using a gas torch, induction coils, or other approved method. Heat should be used to remove any moisture before welding. Monitor temperature using tempil sticks, contact pyrometer, or infrared gun. Wrought iron pipe will be preheated to 250 °F. |                                |   |

**Welding Procedure Specification  
WPS SMAW B-X70 Fillet 0.188"-0.750"**

|   |  |                         |                                |                         |
|---|--|-------------------------|--------------------------------|-------------------------|
| Post Weld Heat Treatment  | <input type="checkbox"/> Yes <input checked="" type="checkbox"/> No                            |                         | Time N/A<br>Temperature N/A °F |                         |
| Cleaning and/or Grinding  | <input checked="" type="checkbox"/> Hand Tools <input checked="" type="checkbox"/> Power Tools |                         |                                |                         |
| Time Between Passes (mins)  | All Passes without delay   |                         |                                |                         |
| Welding Pass  | Root Bead (RB)   | Hot (H)                 | Fills (F)                      | Cap (C)                 |
| Welding Process   | SMAW   | SMAW                    | SMAW                           | SMAW                    |
| Direction of Welding  | Downhill and Horizontal  | Downhill and Horizontal | Downhill or Horizontal         | Downhill and Horizontal |
| Polarity  | DCRP (+)   | DCRP (+)                | DCRP (+)                       | DCRP (+)                |
| Deposition Method   | Stringer/Weave   | Stringer/Weave          | Stringer/Weave                 | Stringer/Weave          |
| AWS Specification   | Pipe Grade<br>A5.1   | A5.1                    | A5.1                           | A5.1                    |
| AWS Classification  | gr.B-X42   | E6010                   | E6010                          | E6010                   |
|   | X46-X65  | E6010                   | E7010                          | E7010                   |
|   | X70  | E6010                   | E8010                          | E8010                   |
| Electrode Diameter(s)   | 1/8  | 5/32                    | 5/32                           | 5/32                    |
| Arc Voltage – Min (preferred) Max   | 18 - (20-25) - 35  | 18 - (22-28) - 34       | 18 - (22-28) - 34              | 18 - (22-28) - 34       |
| Amperage – Min (preferred) Max  | 80 - (90-120) - 190  | 90 - (130-170) - 200    | 90 - (130-170) - 200           | 90 - (130-170) - 200    |
| Travel Speed Range (inch/min)   | 3-15   | 3-18                    | 3-18                           | 3-18                    |
| Minimum Number of Passes  | Wall Thickness Range (in)  | Number of Passes        |                                | Number of Cap Passes    |
|   | ≥ 0.188 to 0.250   | 3                       |                                | 1                       |
|   | ≥ 0.250 to 0.500   | 4                       |                                | 1                       |
|   | ≥ 0.500 through 0.750  | 5                       |                                | 2                       |
|   |  |                         |                                |                         |
| Notes   | Stripper beads are optional and do not count toward the minimum number of passes.              |                         |                                |                         |
| Optional Electrode Diameters  |  |                         |                                |                         |
| E7010 Electrode AWS Specification A5.5 may be substituted for any single or multiple passes for Grade X65 or less |  |                         |                                |                         |
| Welding Pass  | RB, H  | H, F, C                 | H, F, C                        | F, C                    |
| Diameter  | 3/32   | 1/8                     | 5/32                           | 3/16                    |
| Arc Voltage – Min (preferred) Max   | 18 - (20-25) - 35  | 18 - (20-25) - 35       | 18 - (22-28) - 34              | 18 - (22-28) - 34       |
| Amperage – Min (preferred) Max  | 40 - (50-80) - 190   | 50 - (90-120) - 190     | 90 - (130-160) - 200           | 110 - (160-200) - 225   |
| Travel Speed (ipm)  | 3 - 18   | 3 - 18                  | 3 - 18                         | 3 - 18                  |
| Submittal   | Author: Robert W. Lawless  |                         | Title: Gas Standards Engineer  |                         |
|   | Company/Organization: NiSource Gas Distribution  |                         |                                | Date: 09/19/2011        |
| Approval  | Title  | Name                    |                                | Date                    |
|   | Gas Standard Engineer  | Robert W. Lawless       |                                | 09/19/2011              |
| Revision Approval   | Gas Standard Engineer  | Robert W. Lawless       |                                | 02/13/2013              |



**Welding Procedure Specification  
WPS SMAW IN-SERVICE**

|   |  |                     |                     |                      |
|---|--|---------------------|---------------------|----------------------|
| Post Weld Heat Treatment  | <input type="checkbox"/> Yes <input checked="" type="checkbox"/> No  |                     | Time Temperature °F |                      |
| Cleaning and/or Grinding  | <input checked="" type="checkbox"/> Hand Tools <input checked="" type="checkbox"/> Power Tools   |                     |                     |                      |
| <b>Branch Fillets and Sleeve Fillets</b>  |  |                     |                     |                      |
| Time Between Passes (mins)  | Root and Hot – 5 max. Time Between Hot and First Fill – 10 max when wall thickness exceeds 0.500". Remaining Passes – Without Delay after cleaning and grinding. |                     |                     |                      |
| Welding Pass  | Root Bead (RB)   | Hot (H)             | Fills (F)           | Cap (C)              |
| Welding Process   | SMAW   | SMAW                | SMAW                | SMAW                 |
| Direction of Welding  | Vertical Up  | Vertical Up         | Vertical Up         | Vertical Up          |
| Polarity  | DCRP (+)   | DCRP (+)            | DCRP (+)            | DCRP (+)             |
| Deposition Method   | Stringer   | Stringer            | Stringer/Weave      | Stringer/Weave       |
| AWS Specification   | A5.5   | A5.5                | A5.5                | A5.5                 |
| AWS Classification  | Grades B-X52   | E7018               | E7018               | E7018                |
|   | Grades X56-X70   | E8018               | E8018               | E8018                |
| Electrode Diameter(s)   | 3/32   | 3/32                | 3/32                | 3/32                 |
| Arc Voltage – Min (preferred) Max   | 18 – (20-25) – 32  | 18 – (20-25) – 32   | 18 – (20-25) – 32   | 18 – (20-25) – 32    |
| Amperage – Min (preferred) Max  | 40 – (50-80) – 100   | 50 – (90-120) – 180 | 50 – (90-120) – 180 | 50 – (90-120) – 180  |
| Travel Speed Range (inch/min)   | 2 – 18   | 3 – 18              | 3 – 18              | 3 - 18               |
| Minimum Number of Passes  | Wall Thickness Range (in)  | Number of Passes    |                     | Number of Cap Passes |
|   | < 0.188  | 3                   |                     | 1                    |
|   | ≥ 0.188 to 0.250   | 3                   |                     | 1                    |
|   | ≥ 0.250 to 0.500   | 4                   |                     | 1                    |
|   | ≥ 0.500 through 0.750  | 5                   |                     | 2                    |
|   | > .750   | 6                   |                     | 2                    |
| Notes   | Stripper beads are optional and do not count toward the minimum number of passes.  |                     |                     |                      |
| Optional Electrode Diameters – 7018 A5.5 Electrodes may be substituted for 8018 electrodes for X56-X70 pipe |  |                     |                     |                      |
| Welding Pass  | RB , H   | H, F, C             |                     |                      |
| Diameter  | 3/32   | 1/8                 |                     |                      |
| Arc Voltage – Min (preferred) Max   | 18 – (20-25) – 32  | 18 – (20-25) – 32   |                     |                      |
| Amperage – Min (preferred) Max  | 40 – (50-80) – 100   | 50 – (90-120) – 180 |                     |                      |
| Travel Speed (ipm)  | 2 – 18   | 3 - 18              |                     |                      |

Welding Procedure Specification  
WPS SMAW IN-SERVICE

| Longitudinal Seam Welds See below for Low Hydrogen rod option  |   |  |  |  |
|--|---|--|--|--|
| Time Between Passes (mins)   | Root and Hot 5 max. Time Between Hot and First Fill – 10 max when wall thickness exceeds 0.500". All other passes within 15 Minutes. If 15 minutes as exceeded, then the weld shall be preheated to 250 -350 degrees F. |  |  |  |
| Welding Pass   | Root Bead (RB)  | Hot (H)  | Fills (F)  | Cap (C)  |
| Welding Process  | SMAW  | SMAW   | SMAW   | SMAW   |
| Direction of Welding   | Horizontal or Downhill  | Horizontal or Downhill   | Horizontal or Downhill   | Horizontal or Downhill   |
| Polarity   | DCRP (+)  | DCRP (+)   | DCRP (+)   | DCRP (+)   |
| Deposition Method  | Stringer  | Stringer   | Stringer/Weave   | Stringer/Weave   |
| AWS Specification  | A5.1  | E6010 A5.1<br>E7010, E8010 A5.5                                | E6010 A5.1<br>E7010, E8010 A5.5                                | E6010 A5.1<br>E7010, E8010 A5.5                                |
| AWS Classification   | Grade B-X70 E6010   | Grade B-X42 E6010<br>Grade X46-X65<br>E7010<br>Grade X70 E8010 | Grade B-X42 E6010<br>Grade X46-X65<br>E7010<br>Grade X70 E8010 | Grade B-X42 E6010<br>Grade X46-X65<br>E7010<br>Grade X70 E8010 |
| Electrode Diameter(s)  | 1/8   | 5/32   | 5/32   | 5/32   |
| Arc Voltage – Min (preferred) Max  | 18 – (20-25) – 35   | 18 – (22-28) – 34  | 18 - (22-28) - 34  | 18 - (22-28) – 34  |
| Amperage – Min (preferred) Max   | 80 – (90-120) – 190   | 90 – (130-170) – 200   | 90 – (130-170) – 200   | 90 – (130-170) – 200   |
| Travel Speed Range (inch/min)  | 3 – 15  | 3 - 18   | 3 – 18   | 3 - 18   |
| Minimum Number of Passes   | Wall Thickness Range (in)   | Number of Passes   |  | Number of Cap Passes   |
|  | < 0.188   | 3  |  | 1  |
|  | ≥ 0.188 to 0.250  | 3  |  | 1  |
|  | ≥ 0.250 to 0.500  | 4  |  | 1  |
|  | ≥ 0.500 through 0.750   | 5  |  | 2  |
|  | > .750  | 6  |  | 2  |
| Notes  | Stripper beads are optional and do not count toward the minimum number of passes.   |  |  |  |
| Optional Electrode Diameters – E7010 may be substituted for E6010 for any pass. E8010 electrode may be substituted for 7010 electrodes for X65 pipe grade. |   |  |  |  |
| Welding Pass   | RB , H  | RB,H,F,C   | RB, H, F, C  | F, C   |
| Diameter   | 3/32  | 1/8  | 5/32   | 3/16   |
| Arc Voltage – Min (preferred) Max  | 18 – (20-25) - 35   | 18 – (20-25) – 35  | 18 – (22-28) – 34  | 18 – (22-28) - 34  |
| Amperage – Min (preferred) Max   | 40 – (50-80) – 190  | 50 – (90-120) – 190  | 90 – (130-160) – 200   | 110 – (160-200) –225   |
| Travel Speed (ipm)   | 3 – 18  | 3 – 18   | 3 – 18   | 3 – 18   |
|  |   |  |  |  |

**Welding Procedure Specification  
WPS SMAW IN-SERVICE**

| Longitudinal Seam Welds Low Hydrogen rods  |   |   |   |   |
|--|---|---|---|---|
| Time Between Passes (mins)   | Root and Hot 5 max. Time Between Hot and First Fill – 10 max when wall thickness exceeds 0.500". All other passes within 15 Minutes. If 15 minutes as exceeded, then the weld shall be preheated to 250 -350 degrees F. |   |   |   |
| Welding Pass   | Root Bead (RB)  | Hot (H)                                     | Fills (F)                                   | Cap (C)                                     |
| Welding Process  | SMAW  | SMAW  | SMAW  | SMAW  |
| Direction of Welding   | Vertical Up   | Vertical Up                                 | Vertical Up                                 | Vertical Up                                 |
| Polarity   | DCRP (+)  | DCRP (+)                                    | DCRP (+)                                    | DCRP (+)                                    |
| Deposition Method  | Stringer/Weave  | Stringer/Weave                              | Stringer/Weave                              | Stringer/Weave                              |
| AWS Specification  | A5.5  | A5.5  | A5.5  | A5.5  |
| AWS Classification   | Grade B-X60 E7018<br>Grade X65-X70<br>E8018   | Grade B-X60 E7018<br>Grade X65-X70<br>E8018 | Grade B-X60 E7018<br>Grade X65-X70<br>E8018 | Grade B-X60 E7018<br>Grade X65-X70<br>E8018 |
| Electrode Diameter(s)  | 3/32  | 3/32  | 3/32  | 3/32  |
| Arc Voltage – Min (preferred) Max  | 18 – (20-25) – 32   | 18 – (20-25) – 32                           | 18 – (20-25) – 32                           | 18 – (20-25) – 32                           |
| Amperage – Min (preferred) Max   | 40 – (50-80) - 100  | 40 – (50-80) – 100                          | 40 – (50-80) – 100                          | 40 – (50-80) – 100                          |
| Travel Speed Range (inch/min)  | 2 - 18  | 2 – 18                                      | 2 – 18                                      | 2 - 18                                      |
| Minimum Number of Passes   | Wall Thickness Range (in)   | Number of Passes                            |   | Number of Cap Passes                        |
|  | < 0.188   | 3   |   | 1   |
|  | ≥ 0.188 to 0.250  | 3   |   | 1   |
|  | ≥ 0.250 to 0.500  | 4   |   | 1   |
|  | ≥ 0.500 through 0.750   | 5   |   | 2   |
|  | > .750  | 6   |   | 2   |
| Notes  | Stripper beads are optional and do not count toward the minimum number of passes.   |   |   |   |
| Optional Electrode Diameters 7018 A5.5 electrodes may be substituted for 8018 electrodes for X65-X70 pipe. |   |   |   |   |
| Welding Pass   | RB, H, F, C   | RB, H, F, C                                 | H, F, C                                     | F, C  |
| Diameter   | 3/32  | 5/32  |   |   |
| Arc Voltage – Min (preferred) Max  | 18 – (20-25) – 32   | 18 – (20-25) – 32                           |   |   |
| Amperage – Min (preferred) Max   | 40 – (50-80) – 100  | 50 – (90-120) – 180                         |   |   |
| Travel Speed (ipm)   | 2 – 18  | 3 - 18                                      |   |   |
| Submittal  | Author: Robert W. Lawless   |   | Title: Gas Standard Engineer                |   |
|  | Company/Organization:   |   |   | Date: 09/20/2011                            |
| Approval   | Title   | Name  | Date  |   |
|  | Gas Standards Engineer  | Robert W. Lawless                           | 09/20/2011                                  |   |
| Revision Approval  | Gas Standards Engineer  | Robert W. Lawless                           | 02/13/2013                                  |   |

**Welding Procedure Specification  
 WPS SMAW Fixed Groove 0.188"-0.750"**

|  |   |                 |  |
|--|---|-----------------|--|
| Applicable Codes and Specifications                  | API Standard 1104 20 <sup>th</sup> Edition  | Date: 2/10/2011 | Revision Date:<br>02/08/2013   |
| Supporting PQR                                       | Procedure Qualification Record (PQR): SC/122-G, SMAW X65/X70 Fixed Groove 188-750, SMAW X60 Fixed Groove 188-750  |                 |  |
| Process and Method                                   | Shielded Metal Arc Welding<br>Manual  |                 |  |
| Materials, Diameter, and Wall Thickness              | Materials:  | Diameter:       | Wall Thickness:  |
|  | <input checked="" type="checkbox"/> API 5L X42, Grade B<br><input checked="" type="checkbox"/> API 5L X46, X52, X56, X60<br><input checked="" type="checkbox"/> API 5L X65<br><input type="checkbox"/> API 5L X70   | All Diameters   | <input type="checkbox"/> Under 0.188<br><input checked="" type="checkbox"/> 0.188 through 0.750<br><input type="checkbox"/> Over 0.750 |
| Joint Design Butt and Fillet                         |   |                 |  |
| Position of Pipe Axis                                | <input checked="" type="checkbox"/> Flat (1G) <input checked="" type="checkbox"/> Multiple (5G)<br><input checked="" type="checkbox"/> Horizontal (2G) <input checked="" type="checkbox"/> Inclined (6G)<br><input checked="" type="checkbox"/> Vertical (3G) <input checked="" type="checkbox"/> Fixed<br><input checked="" type="checkbox"/> Overhead (4G) <input type="checkbox"/> Rolled  |                 |  |
| Minimum Number of Welders                            | One welder for OD < 16" NPS, two welders required for OD ≥ 16" NPS.   |                 |  |
| Type & Removal of Lineup Clamp                       | None required. When used the requirements are<br>External - 50% of root bead must be completed before removal<br>OR<br>Internal - 100% of root bead must be complete before removal   |                 |  |
| Preheating: Method, Temperature, Temperature Control | Above 40 °F                      40 °F and Below<br>None Required                    150 °F minimum<br>For wall thicknesses exceeding 0.500", preheat pipe to 200 °F.<br>Preheat to 250 °F – 350 °F max. for all welding repairs using this procedure.<br>Heat using a gas torch, induction coils, or other approved method. Heat should be used to remove any moisture before welding. Monitor temperature using tempil sticks, contact pyrometer, or infrared gun. Wrought iron pipe will be preheated to 250 °F. |                 |  |

**Welding Procedure Specification  
WPS SMAW Fixed Groove 0.188"-0.750"**

|   |   |   |   |   |
|---|---|---|---|---|
| Post Weld Heat Treatment  | <input type="checkbox"/> Yes <input checked="" type="checkbox"/> No   | Time N/A<br>Temperature N/A °F                                  |   |   |
| Cleaning and/or Grinding  | <input checked="" type="checkbox"/> Hand Tools <input checked="" type="checkbox"/> Power Tools  |   |   |   |
| Time Between Passes (mins)  | Root and Hot 5 max. Time Between Hot and First Fill - 10 max when wall thickness exceeds 0.500". All other passes within 15 Minutes. If 15 minutes as exceeded, then the weld shall be preheated to 250 -350 degrees F. |   |   |   |
| Welding Pass  | Root Bead (RB)  | Hot (H)   | Fills (F)   | Cap (C)   |
| Welding Process   | SMAW  | SMAW  | SMAW  | SMAW  |
| Direction of Welding  | Vertical Down   | Vertical Down   | Vertical Down   | Vertical Down   |
| Polarity  | DCRP (+)  | DCRP (+)  | DCRP (+)  | DCRP (+)  |
| Deposition Method   | Stringer/Weave  | Stringer/Weave  | Stringer/Weave  | Stringer/Weave  |
| AWS Specification   | A5.1  | E6010 A5.1<br>E7010, E8010 A5.5                                 | E6010 A5.1<br>E7010, E8010 A5.5                                 | E6010 A5.1<br>E7010, E8010 A5.5                                 |
| AWS Classification  | Grade B-X70 E6010   | Grade B-X42 E6010<br>Grade X46-X60 E7010<br>Grade X65-X70 E8010 | Grade B-X42 E6010<br>Grade X46-X60 E7010<br>Grade X65-X70 E8010 | Grade B-X42 E6010<br>Grade X46-X60 E7010<br>Grade X65-X70 E8010 |
| Electrode Diameter(s)   | 1/8   | 5/32  | 5/32  | 5/32  |
| Arc Voltage – Min (preferred) Max   | 18 - (20-25) - 35   | 18 - (22-28) - 34   | 18 - (22-28) - 34   | 18 - (22-28) - 34   |
| Amperage – Min (preferred) Max  | 80 - (90-120) - 190   | 90 -(130-170)- 200  | 90 -(130-170)- 200  | 90 -(130-170)- 200  |
| Travel Speed Range (inch/min)   | 3 - 15  | 3 - 18  | 3 - 18  | 3 - 18  |
| Minimum Number of Passes  | Wall Thickness Range (in)   | Number of Passes  |   | Number of Cap Passes  |
|   | < 0.188   | 3   |   | 1   |
|   | ≥ 0.188 to 0.250  | 3   |   | 1   |
|   | ≥ 0.250 to 0.500  | 4   |   | 1   |
|   | ≥ 0.500 through 0.750   | 5   |   | 2   |
| Notes   | Stripper beads are optional and do not count toward the minimum number of passes.   |   |   |   |
| Optional Electrode Diameters  |   |   |   |   |
| E7010 Electrode AWS Specification A5.5 may be substituted for E6010 rods for any pass |   |   |   |   |
| Welding Pass  | RB, H   | RB,H, F, C  | RB,H, F, C  | F, C  |
| Diameter  | 3/32  | 1/8   | 5/32  | 3/16  |
| Arc Voltage – Min (preferred) Max   | 18 - (20-25) - 35   | 18 - (20-25) - 35   | 18 - (22-28) - 34   | 18 - (22-28) - 34   |
| Amperage – Min (preferred) Max  | 40 - (50-80) - 190  | 50 - (90-120) - 190   | 90 - (130-160) - 200  | 110 - (160-200) -225  |
| Travel Speed (ipm)  | 3 - 18  | 3 - 18  | 3 - 18  | 3 - 18  |
| Submittal   | Author: Robert W. Lawless   |   | Title: Gas Standards Engineer                                   |   |
|   | Company/Organization: NiSource Gas Distribution   |   |   | Date:2/10/2011  |
| Approval  | Title   | Name  |   | Date  |
|   | Gas Standard Engineer   | Robert W. Lawless   |   | 2/10/2011   |



**Welding Procedure Specification  
 WPS Repairs on GMAW Welds Using SMAW**

|  |  |                            |  |
|--|--|----------------------------|--|
| Applicable Codes and Specifications                  | API Standard 1104 20 <sup>th</sup> Edition   | Date: 1/20/2012            | Revision Date:   |
| Supporting PQR                                       | Procedure Qualification Record (PQR): PQR X42 Repair Using SMAW on GMAW Welds , PQR X60 Repair Using SMAW on GMAW Welds and PQR X65 Repair Using SMAW on GMAW Welds  |                            |  |
| Process and Method                                   | Shielded Metal Arc Welding<br>Manual   |                            |  |
| Materials, Diameter, and Wall Thickness              | Materials:<br>Materials with Specified Minimum Yield Strength less than or equal to 65000 psi  | Diameter:<br>All Diameters | Repair Thickness:<br><input checked="" type="checkbox"/> Under 0.188<br><input checked="" type="checkbox"/> 0.188 through 0.750<br><input type="checkbox"/> Over 0.750 |
| Joint Design   |  |                            |  |
| Position of Pipe Axis                                | <input checked="" type="checkbox"/> Fixed<br><input type="checkbox"/> Rolled   |                            |  |
| Minimum Number of Welders                            | One welder   |                            |  |
| Type & Removal of Lineup Clamp                       | None required.   |                            |  |
| Preheating: method, temperature, temperature control | Preheat to 250 °F – 350 °F max. Heat using a gas torch, induction coils, or other approved method. Monitor temperature using tempil sticks, contact pyrometer, or infrared gun. No Interpass heat treatment is required. |                            |  |

|                          |   |                     |
|--------------------------|---|---------------------|
| Post Weld Heat Treatment | <input type="checkbox"/> Yes <input checked="" type="checkbox"/> No | Time Temperature °F |
|--------------------------|---|---------------------|

**Welding Procedure Specification  
WPS Repairs on GMAW Welds Using SMAW**

|  |                              |   |                              |                              |                              |
|--|------------------------------|---|------------------------------|------------------------------|------------------------------|
| Cleaning and/or Grinding   |                              | Grinding with power tools will be used to explore and completely remove defect. The repair groove shall be examined to verify the removal of the defect before repair welding begins.<br><input checked="" type="checkbox"/> Hand Tools <input checked="" type="checkbox"/> Power Tools |                              |                              |                              |
| Time Between Passes (mins)   |                              | Root and Hot 5 Max. (if root is required) Time Between remaining passes – 10 minutes. Welds repair shall be completed and not left uncompleted.   |                              |                              |                              |
| Interpass Nondestructive testing is not required   |                              |   |                              |                              |                              |
| Welding Pass   |                              | Root Bead (RB)  | Hot (H)                      | Fills (F)                    | Cap (C)                      |
| Welding Process  |                              | SMAW  | SMAW                         | SMAW                         | SMAW                         |
| Direction of Welding   |                              | Vertical Down   | Vertical Down                | Vertical Down                | Vertical Down                |
| Polarity   |                              | DCRP (+)  | DCRP (+)                     | DCRP (+)                     | DCRP (+)                     |
| Deposition Method  |                              | Stringer/Weave  | Stringer/Weave               | Stringer/Weave               | Stringer/Weave               |
| AWS Specification  |                              | A5.1 E6010, A5.5 E7010, 8010  | A5.1 E6010, A5.5 E7010, 8010 | A5.1 E6010, A5.5 E7010, 8010 | A5.1 E6010, A5.5 E7010, 8010 |
| AWS Classification   | SMYS ≤ 42000 psi             | E6010   | E6010                        | E6010                        | E6010                        |
|  | 42000 psi < SMYS ≤ 60000 psi |   | E7010                        | E7010                        | E7010                        |
|  | SMYS > 60000 psi             |   | E8010                        | E8010                        | E8010                        |
| Electrode Diameter(s)  |                              | 5/32  | 5/32                         | 5/32                         | 5/32                         |
| Arc Voltage – Min (preferred) Max  |                              | 18 – (22-28) - 34   | 18 – (22-28) - 34            | 18 – (22-28) - 34            | 18 – (22-28) - 34            |
| Amperage – Min (preferred) Max   |                              | 87 – (130-170) - 200  | 87–(130-170)-200             | 87–(130-170)-200             | 87–(130-170)-200             |
| Travel Speed Range (inch/min)  |                              | 3 - 18  | 3 - 18                       | 3 - 18                       | 3 - 18                       |
| Minimum number of Passes   |                              | Repair Thickness Range (in)   | Number of passes             | Number of Cap Passes         |                              |
|  |                              | < 0.188   | 2                            | 1                            |                              |
|  |                              | ≥ 0.188 to 0.250  | 3                            | 1                            |                              |
|  |                              | ≥ 0.250 to 0.500  | 4                            | 1                            |                              |
|  |                              | ≥ 0.500 through 0.750   | 5                            | 2                            |                              |
|  |                              | > .750  | 6                            | 2                            |                              |
| Notes  |                              | Stripper beads are optional and do not count toward the minimum number of passes.   |                              |                              |                              |
| <b>Optional Electrode</b>  |                              |   |                              |                              |                              |
| E7010 Electrode AWS Specification A5.5 may be substituted for E6010 electrode for any pass |                              |   |                              |                              |                              |
| Welding Pass   |                              | RB, H   | RB, H, F, C                  | F, C                         |                              |
| Diameter   |                              | 3/32  | 1/8                          | 3/16                         |                              |
| Arc Voltage – Min (preferred) Max  |                              | 18 – (20-25) - 35   | 18 – (20-25) - 35            | 18 – (22-28) - 34            |                              |
| Amperage – Min (preferred) Max   |                              | 40 – (50-80) - 190  | 50 – (90-120) - 190          | 90 – (130-160) - 200         |                              |
| Travel Speed (ipm)   |                              | 3 - 18  | 3 - 18                       | 3 - 18                       |                              |
| Submittal  |                              | Author: Robert W. Lawless   |                              | Title: Gas Standard Engineer |                              |
|  |                              | Company/Organization: NiSource Distribution   |                              |                              | Date: 01/20/2012             |
| Approval   |                              | Title   |                              | Name                         | Date                         |
|  |                              | Gas Standards Engineer  |                              | Robert W. Lawless            | 1/20/2012                    |

### Welding Procedure Specification WPS Repairs on SAW Welds Using GMAW

|  |  |                            |  |
|--|--|----------------------------|--|
| Applicable Codes and Specifications                  | API Standard 1104 20 <sup>th</sup> Edition   | Date: 1/20/2012            | Revision Date:   |
| Supporting PQR                                       | Procedure Qualification Record (PQR): PQR X42 Repair Using GMAW on SAW Welds , PQR X60 Repair Using GMAW on SAW Welds and PQR X65 Repair Using GMAW on SAW Welds   |                            |  |
| Process and Method                                   | Gas Metal Arc Welding<br>Semi-automatic  |                            |  |
| Materials, Diameter, and Wall Thickness              | Materials:<br>Materials with Specified Minimum Yield Strength less than or equal to 65000 psi  | Diameter:<br>All Diameters | Repair Thickness:<br><input checked="" type="checkbox"/> Under 0.188<br><input checked="" type="checkbox"/> 0.188 through 0.750<br><input type="checkbox"/> Over 0.750 |
| Joint Design   |  |                            |  |
| Position of Pipe Axis                                | <input checked="" type="checkbox"/> Fixed<br><input type="checkbox"/> Rolled   |                            |  |
| Minimum Number of Welders                            | One welder   |                            |  |
| Type & Removal of Lineup Clamp                       | None required.   |                            |  |
| Preheating: method, temperature, temperature control | Preheat to 250 °F – 350 °F max. Heat using a gas torch, induction coils, or other approved method. Monitor temperature using tempil sticks, contact pyrometer, or infrared gun. No Interpass heat treatment is required. |                            |  |

**Welding Procedure Specification  
WPS Repairs on SAW Welds Using GMAW**

|   |   |                     |                               |                   |
|---|---|---------------------|-------------------------------|-------------------|
| Post Weld Heat Treatment                                  | <input type="checkbox"/> Yes <input checked="" type="checkbox"/> No   | Time Temperature °F |                               |                   |
| Cleaning and/or Grinding                                  | Grinding with power tools will be used to explore and completely remove defect. The repair groove shall be examined to verify the removal of the defect before repair welding begins.<br><input checked="" type="checkbox"/> Hand Tools <input checked="" type="checkbox"/> Power Tools |                     |                               |                   |
| Time Between Passes (mins)                                | Root and Hot 5 Max. (if root is required) Time Between remaining passes – 10 minutes. Welds repair shall be completed and not left uncompleted.   |                     |                               |                   |
| Interpass Nondestructive testing is not required          |   |                     |                               |                   |
| Welding Pass  | Root Bead (RB)  | Hot (H)             | Fills (F)                     | Cap (C)           |
| Welding Process   | GMAW  | GMAW                | GMAW                          | GMAW              |
| Direction of Welding                                      | Vertical Down   | Vertical Down       | Vertical Down                 | Vertical Down     |
| Polarity  | DCRP (+)  | DCRP (+)            | DCRP (+)                      | DCRP (+)          |
| Deposition Method   | Stringer/Weave  | Stringer/Weave      | Stringer/Weave                | Stringer/Weave    |
| AWS Specification   | A5.18   | A5.18               | A5.18                         | A5.18             |
| AWS Classification  | < 65000 PSI<br>SMYS<br>ER70S-6  | ER70S-6             | ER70S-6                       | ER70S-6           |
| Electrode Diameter(s)                                     | 0.035   | 0.035               | 0.035                         | 0.035             |
| Arc Voltage – Min (preferred) Max                         | 16 – (18-20) - 24   | 16 – (18-20) – 24   | 16 – (18-20) - 24             | 16 – (18-20) - 24 |
| Amperage – Min (preferred) Max                            | 75 –(100-180)-180   | 75–(100-180)-180    | 75–(100-180)-180              | 75–(100-180)-180  |
| Travel Speed Range (inch/min)                             | 3 - 15  | 3 – 15              | 3 – 15                        | 3 - 15            |
| Minimum number of Passes                                  | Repair Thickness Range (in)   | Number of passes    | Number of Cap Passes          |                   |
|   | < 0.188   | 2                   | 1                             |                   |
|   | ≥ 0.188 to 0.250  | 3                   | 1                             |                   |
|   | ≥ 0.250 to 0.500  | 4                   | 1                             |                   |
|   | ≥ 0.500 through 0.750   | 5                   | 2                             |                   |
| > .750  | 6   | 2                   |                               |                   |
| Notes   | Stripper beads are optional and do not count toward the minimum number of passes.   |                     |                               |                   |
| Optional Electrode ER80S-6 can be substituted for ER70S-6 |   |                     |                               |                   |
| Welding Pass  | R   | H                   | F                             | C                 |
|   | ER80S-D2  | ER80S-D2            | ER80S-D2                      | ER80S-D2          |
| Diameter  | 0.035"  | 0.035"              | 0.035"                        | 0.035"            |
| Arc Voltage – Min (preferred) Max                         | 16 – (18-20) - 24   | 16 – (18-20) – 24   | 16 – (18-20) – 24             | 16 – (18-20) - 24 |
| Amperage – Min (preferred) Max                            | 75-(100-180)- 180   | 75-(100-180)- 180   | 75-(100-180)- 180             | 75-(100-180)- 180 |
| Travel Speed (ipm)  | 3 – 15  | 3 – 15              | 3 – 15                        | 3 - 15            |
| Submittal   | Author: Robert W. Lawless   |                     | Title: Gas Standards Engineer |                   |
|   | Company/Organization: NiSource Distribution   |                     |                               | Date: 01/20/2012  |
| Approval  | Title   |                     | Name                          | Date              |
|   | Gas Standards Engineer  |                     | Robert W Lawless              | 1/20/2012         |

### Welding Procedure Specification WPS Repairs on SAW Welds Using SMAW

|  |  |                            |  |
|--|--|----------------------------|--|
| Applicable Codes and Specifications                  | API Standard 1104 20 <sup>th</sup> Edition   | Date: 1/20/2012            | Revision Date:   |
| Supporting PQR                                       | Procedure Qualification Record (PQR): PQR X42 Repair Using SMAW on SAW Welds , PQR X60 Repair Using SMAW on SAW Welds and PQR X65 Repair Using SMAW on SAW Welds   |                            |  |
| Process and Method                                   | Shielded Metal Arc Welding<br>Manual   |                            |  |
| Materials, Diameter, and Wall Thickness              | Materials:<br>Materials with Specified Minimum Yield Strength less than or equal to 65000 psi  | Diameter:<br>All Diameters | Repair Thickness:<br><input checked="" type="checkbox"/> Under 0.188<br><input checked="" type="checkbox"/> 0.188 through 0.750<br><input type="checkbox"/> Over 0.750 |
| Joint Design   |  |                            |  |
| Position of Pipe Axis                                | <input checked="" type="checkbox"/> Fixed<br><input type="checkbox"/> Rolled   |                            |  |
| Minimum Number of Welders                            | One welder   |                            |  |
| Type & Removal of Lineup Clamp                       | None required.   |                            |  |
| Preheating: method, temperature, temperature control | Preheat to 250 °F – 350 °F max. Heat using a gas torch, induction coils, or other approved method. Monitor temperature using tempil sticks, contact pyrometer, or infrared gun. No Interpass heat treatment is required. |                            |  |

|                          |   |                        |
|--------------------------|---|------------------------|
| Post Weld Heat Treatment | <input type="checkbox"/> Yes <input checked="" type="checkbox"/> No | Time Temperature    °F |
|--------------------------|---|------------------------|

**Welding Procedure Specification  
WPS Repairs on SAW Welds Using SMAW**

|  |                              |   |                              |                               |                              |
|--|------------------------------|---|------------------------------|-------------------------------|------------------------------|
| Cleaning and/or Grinding   |                              | Grinding with power tools will be used to explore and completely remove defect. The repair groove shall be examined to verify the removal of the defect before repair welding begins.<br><input checked="" type="checkbox"/> Hand Tools <input checked="" type="checkbox"/> Power Tools |                              |                               |                              |
| Time Between Passes (mins)   |                              | Root and Hot 5 Max. (if root is required) Time Between remaining passes – 10 minutes. Welds repair shall be completed and not left uncompleted.   |                              |                               |                              |
| Interpass Nondestructive testing is not required   |                              |   |                              |                               |                              |
| Welding Pass   |                              | Root Bead (RB)  | Hot (H)                      | Fills (F)                     | Cap (C)                      |
| Welding Process  |                              | SMAW  | SMAW                         | SMAW                          | SMAW                         |
| Direction of Welding   |                              | Vertical Down   | Vertical Down                | Vertical Down                 | Vertical Down                |
| Polarity   |                              | DCRP (+)  | DCRP (+)                     | DCRP (+)                      | DCRP (+)                     |
| Deposition Method  |                              | Stringer/Weave  | Stringer/Weave               | Stringer/Weave                | Stringer/Weave               |
| AWS Specification  |                              | A5.1 E6010, A5.5 E7010, 8010  | A5.1 E6010, A5.5 E7010, 8010 | A5.1 E6010, A5.5 E7010, 8010  | A5.1 E6010, A5.5 E7010, 8010 |
| AWS Classification   | SMYS ≤ 42000 psi             | E6010   | E6010                        | E6010                         | E6010                        |
|  | 42000 psi < SMYS ≤ 60000 psi |   | E7010                        | E7010                         | E7010                        |
|  | SMYS > 60000 psi             |   | E8010                        | E8010                         | E8010                        |
| Electrode Diameter(s)  |                              | 5/32  | 5/32                         | 5/32                          | 5/32                         |
| Arc Voltage – Min (preferred) Max  |                              | 18 – (22-28) - 34   | 18 – (22-28) - 34            | 18 – (22-28) - 34             | 18 – (22-28) - 34            |
| Amperage – Min (preferred) Max   |                              | 90 – (130-170) - 200  | 90–(130-170)-200             | 90–(130-170)-200              | 90–(130-170)-200             |
| Travel Speed Range (inch/min)  |                              | 3 - 18  | 3 - 18                       | 3 - 18                        | 3 - 18                       |
| Minimum number of Passes   |                              | Repair Thickness Range (in)   | Number of passes             | Number of Cap Passes          |                              |
|  |                              | < 0.188   | 2                            | 1                             |                              |
|  |                              | ≥ 0.188 to 0.250  | 3                            | 1                             |                              |
|  |                              | ≥ 0.250 to 0.500  | 4                            | 1                             |                              |
|  |                              | ≥ 0.500 through 0.750   | 5                            | 2                             |                              |
|  |                              | > .750  | 6                            | 2                             |                              |
| Notes  |                              | Stripper beads are optional and do not count toward the minimum number of passes.   |                              |                               |                              |
| <b>Optional Electrode</b>  |                              |   |                              |                               |                              |
| E7010 Electrode AWS Specification A5.5 may be substituted for E6010 electrode for any pass |                              |   |                              |                               |                              |
| Welding Pass   |                              | RB, H   | RB, H, F, C                  | F, C                          |                              |
| Diameter   |                              | 3/32  | 1/8                          | 3/16                          |                              |
| Arc Voltage – Min (preferred) Max  |                              | 18 – (20-25) - 35   | 18 – (20-25) - 35            | 18 – (22-28) - 34             |                              |
| Amperage – Min (preferred) Max   |                              | 40 – (50-80) - 190  | 50 – (90-120) - 190          | 90 – (130-160) - 200          |                              |
| Travel Speed (ipm)   |                              | 3 - 18  | 3 - 18                       | 3 - 18                        |                              |
| Submittal  |                              | Author: Robert W. Lawless   |                              | Title: Gas Standards Engineer |                              |
|  |                              | Company/Organization: NiSource Distribution   |                              |                               | Date: 01/20/2012             |
| Approval   |                              | Title   |                              | Name                          |                              |
|  |                              | Gas Standards Engineer  |                              | Robert W. Lawless             |                              |
|  |                              |   |                              | Date                          |                              |
|  |                              |   |                              | 1/20/2012                     |                              |

**Welding Procedure Specification**  
**WPS SMAW Wall Thickness Over 0.750" Butt Weld**

|  |   |                                |   |
|--|---|--------------------------------|---|
| Applicable Codes and Specifications                  | API Standard 1104 20 <sup>th</sup> Edition  | Date: 02/02/2012               | Revision Date:  |
| Supporting PQR                                       | Procedure Qualification Record (PQR): 06R004 and 10R001   |                                |   |
| Process and Method                                   | Shielded Metal Arc Welding<br>Manual  |                                |   |
| Materials, Diameter, and Wall Thickness              | Materials:<br>Materials with SMYS equal to or less than 42,000 PSI  | Diameter:<br>All Diameters     | Wall Thickness:<br><input type="checkbox"/> Under 0.188<br><input type="checkbox"/> 0.188 through 0.750<br><input checked="" type="checkbox"/> Over 0.750 |
| Joint Design   |   |                                |   |
| Position of Pipe Axis                                | <input checked="" type="checkbox"/> Flat (1G) <input checked="" type="checkbox"/> Multiple (5G)<br><input checked="" type="checkbox"/> Horizontal (2G) <input checked="" type="checkbox"/> Inclined (6G)<br><input checked="" type="checkbox"/> Vertical (3G) <input checked="" type="checkbox"/> Fixed<br><input checked="" type="checkbox"/> Overhead (4G) <input type="checkbox"/> Rolled  |                                |   |
| Minimum Number of Welders                            | One welder for OD < 16" NPS, two welders required for OD ≥ 16" NPS.   |                                |   |
| Type & Removal of Lineup Clamp                       | None required. When used the requirements are<br>External - 50% of root bead must be completed before removal<br>OR<br>Internal - 100% of root bead must be complete before removal   |                                |   |
| Preheating: method, temperature, temperature control | <u>Above 40 °F</u> <u>40 °F and Below</u><br>None Required                                      150 °F minimum<br>For wall thicknesses exceeding 0.500", preheat pipe to 250 °F.<br>Preheat to 250 °F – 350 °F max. for all welding repairs using this procedure.<br>Heat using a gas torch, induction coils, or other approved method. Heat should be used to remove any moisture before welding. Monitor temperature using tempil sticks, contact pyrometer, or infrared gun. |                                |   |
| Post Weld Heat Treatment                             | <input type="checkbox"/> Yes <input checked="" type="checkbox"/> No   | Time N/A<br>Temperature N/A °F |   |

**Welding Procedure Specification**  
**WPS SMAW Wall Thickness Over 0.750" Butt Weld**

|  |   |  |                     |                               |                      |
|--|---|--|---------------------|-------------------------------|----------------------|
| Cleaning and/or Grinding   |   | <input checked="" type="checkbox"/> Hand Tools <input checked="" type="checkbox"/> Power Tools   |                     |                               |                      |
| Time Between Passes (mins)   |   | Root and Hot 5 max. Time Between Hot and First Fill - 10 max when wall thickness exceeds 0.500". All other passes within 15 Minutes when half the groove is not filled. If 15 minutes as exceeded, then the weld shall be preheated to 250 -350 degrees F. If half the groove is filled then time between remaining passes is 72 hours and preheat according to the preheat section in this WPS. |                     |                               |                      |
| Welding Pass   |   | Root Bead (RB)   | Hot (H)             | Fills (F)                     | Cap (C)              |
| Welding Process  |   | SMAW   | SMAW                | SMAW                          | SMAW                 |
| Direction of Welding   |   | Vertical Down  | Vertical Down       | Vertical Down                 | Vertical Down        |
| Polarity   |   | DCRP (+)   | DCRP (+)            | DCRP (+)                      | DCRP (+)             |
| Deposition Method  |   | Stringer/Weave   | Stringer/Weave      | Stringer/Weave                | Stringer/Weave       |
| AWS Specification  | E6010                                       | A5.1   | A5.1                | A5.1                          | A5.1                 |
|  | E8010                                       | A5.5   | A5.5                | A5.5                          | A5.5                 |
| AWS Classification   | SMYS ≤ 42000 PSI                            | E6010  | E6010               | E6010                         | E6010                |
|  | SMYS ≤ 56000 PSI                            | E8010  | E8010               | E8010                         | E8010                |
| Electrode Diameter(s)  |   | 5/32   | 5/32                | 5/32                          | 5/32                 |
| Arc Voltage – Min (preferred) Max  |   | 18 - (22-28) - 34  | 18 - (22-28) - 34   | 18 - (22-28) - 34             | 18 - (22-28) - 34    |
| Amperage – Min (preferred) Max   |   | 90 -(130-170)- 200   | 90 -(130-170)- 200  | 90 -(130-170)- 200            | 90 -(130-170)- 200   |
| Travel Speed Range (inch/min)  |   | 4 - 18   | 4 - 18              | 4 - 18                        | 4 - 18               |
| Minimum number of Passes   | Wall Thickness Range (in)                   |  | Number of passes    |                               | Number of Cap Passes |
|  | < 0.188                                     |  | 3                   |                               | 1                    |
|  | ≥ 0.188 to 0.250                            |  | 3                   |                               | 1                    |
|  | ≥ 0.250 to 0.500                            |  | 4                   |                               | 1                    |
|  | ≥ 0.500 through 0.750                       |  | 5                   |                               | 2                    |
| > .750   |   | 6  |                     | 2                             |                      |
| Notes  |   | Stripper beads are optional and do not count toward the minimum number of passes.  |                     |                               |                      |
| E7010 Electrodes A5.1 can be substituted for E6010 Electrodes for any passes |   |  |                     |                               |                      |
| Optional Electrode Diameters   |   |  |                     |                               |                      |
| Welding Pass   |   | RB, H  | H, F, C             | H, F, C                       | F, C                 |
| Diameter   |   | 3/32   | 1/8                 | 5/32                          | 3/16                 |
| Arc Voltage – Min (preferred) Max  |   | 18 - (20-25) - 32  | 18 - (20-25) - 32   | 18 - (22-28) - 34             | 18 - (22-28) - 34    |
| Amperage – Min (preferred) Max   |   | 40 - (50-80) - 100   | 50 - (90-120) - 180 | 90 - (130-160) - 200          | 110 - (160-200) -225 |
| Travel Speed (ipm)   |   | 4 - 18   | 4 - 18              | 4 - 18                        | 4 - 18               |
| Submittal  | Author: Robert W. Lawless                   |  |                     | Title: Gas Standards Engineer |                      |
|  | Company/Organization: Nisource Distribution |  |                     | Date: 03/02/2012              |                      |
| Approval   | Title                                       |  | Name                |                               | Date                 |
|  | Gas Standards Engineer                      |  | Robert W. Lawless   |                               | 03/02/2012           |
|  |   |  |                     |                               |                      |



Welding Procedure Specification

WPS SMAW Double Repair Grade B -X42

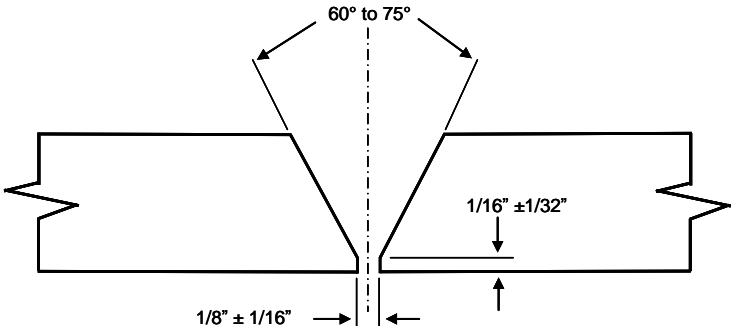
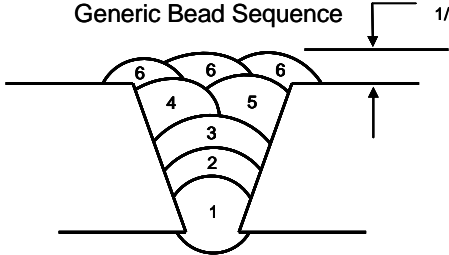
|  |  |                                |   |
|--|--|--------------------------------|---|
| Applicable Codes and Specifications                  | API Standard 1104 20 <sup>th</sup> Edition   | Date: 1/19/2012                | Revision Date:  |
| Supporting PQR                                       | Procedure Qualification Record (PQR):<br>PQR X42 Double Repair SMAW Partial Wall and PQR X42 Double Repair SMAW Thru Wall  |                                |   |
| Process and Method                                   | Shielded Metal Arc Welding<br><br>Manual   |                                |   |
| Materials, Diameter, and Wall Thickness              | Materials:<br><input checked="" type="checkbox"/> API 5L X42, Grade B<br><input type="checkbox"/> API 5L X46, X52, X56, X60<br><input type="checkbox"/> API 5L X65<br><input type="checkbox"/> API 5L X70  | Diameter:<br><br>All Diameters | Wall Thickness:<br><input type="checkbox"/> Under 0.188<br><input checked="" type="checkbox"/> 0.188 through 0.750<br><input type="checkbox"/> Over 0.750 |
| Joint Design Butt and Fillet                         |  |                                |   |
| Position of Pipe Axis                                | <input checked="" type="checkbox"/> Flat (1G) <input checked="" type="checkbox"/> Multiple (5G)<br><input checked="" type="checkbox"/> Horizontal (2G) <input checked="" type="checkbox"/> Inclined (6G)<br><input checked="" type="checkbox"/> Vertical (3G) <input checked="" type="checkbox"/> Fixed<br><input checked="" type="checkbox"/> Overhead (4G) <input type="checkbox"/> Rolled |                                |   |
| Minimum Number of Welders                            | One welder for OD < 14" NPS, two welders required for OD ≥ 14" NPS.  |                                |   |
| Type & Removal of Lineup Clamp                       | External - 50% of root bead must be completed before removal<br>OR<br>Internal - 100% of root bead must be complete before removal   |                                |   |
| Preheating: Method, Temperature, Temperature Control | Preheat to 300 °F.<br>Heat using a gas torch, induction coils, or other approved method. Monitor temperature using tempil sticks, contact pyrometer, or infrared gun.  |                                |   |

Welding Procedure Specification

WPS SMAW Double Repair Grade B -X42

|                                   |  |                        |                                |                         |
|-----------------------------------|--|------------------------|--------------------------------|-------------------------|
| Post Weld Heat Treatment          | Yes No   |                        | Time N/A<br>Temperature N/A °F |                         |
| Cleaning and/or Grinding          | Hand Tools Power Tools   |                        |                                |                         |
| Time Between Passes (mins)        | Root and Hot 3.75. Time Between Hot and First Fill - 10 max when wall thickness exceeds 0.500". All other passes within 15 minutes |                        |                                |                         |
| Welding Pass                      | Root Bead (RB)   | Hot (H)                | Fills (F)                      | Cap (C)                 |
| Welding Process                   | SMAW   | SMAW                   | SMAW                           | SMAW                    |
| Direction of Welding              | Downhill and Horizont  | Downhill and Horizonta | Downhill or Horizontal         | Downhill and Horizontal |
| Polarity                          | DCRP (+)   | DCRP (+)               | DCRP (+)                       | DCRP (+)                |
| Deposition Method                 | Stringer   | Stringer               | Stringer/Weave                 | Stringer/Weave          |
| AWS Specification                 | A5.1   | A5.1                   | A5.1                           | A5.1                    |
| AWS Classification                | E6010  | E6010                  | E6010                          | E6010                   |
| Electrode Diameter(s)             | 5/32   | 5/32                   | 5/32                           | 5/32                    |
| Arc Voltage – Min (preferred) Max | 18 – (22-28) - 34  | 18 – (22-28) - 34      | 18 – (22-28) - 34              | 18 – (22-28) - 34       |
| Amperage – Min (preferred) Max    | 90 – (130-160) - 200   | 90 – (130-160) - 200   | 90 – (130-160) - 200           | 90 – (130-160) - 200    |
| Travel Speed Range (inch/min)     | 4 – 18   | 4 – 18                 | 4 – 18                         | 4 - 18                  |
| Minimum Number of Passes          | Wall Thickness Range (in)  |                        | Number of Passes               | Number of Cap Passes    |
|                                   | < 0.188  |                        | 3                              | 1                       |
|                                   | ≥ 0.188 to 0.250   |                        | 3                              | 1                       |
|                                   | ≥ 0.250 to 0.500   |                        | 4                              | 1                       |
|                                   | ≥ 0.500 to 0.750   |                        | 5                              | 2                       |
| Notes                             | Stripper beads are optional and do not count toward the minimum number of passes.  |                        |                                |                         |
| Optional Electrode Diameters      |  |                        |                                |                         |
| Welding Pass                      | RB, H  | H, F, C                |                                |                         |
| Diameter                          | 3/32   | 1/8                    |                                |                         |
| Arc Voltage – Min (preferred) Max | 18 - (20-25) - 32  | 18 - (20-25) - 32      |                                |                         |
| Amperage – Min (preferred) Max    | 40 - (50-80) - 100   | 50 - (90-120) - 180    |                                |                         |
| Travel Speed (ipm)                | 4 - 18   | 4 - 18                 |                                |                         |
| Submittal                         | Author: Robert W. Lawless  |                        | Title: Gas Standards Engineer  |                         |
|                                   | Company/Organization: NiSource   |                        |                                | Date: 10/25/2012        |
| Approval                          | Title  |                        | Name                           |                         |
|                                   | Gas Standards Engineer   |                        | Robert W. Lawless              |                         |

Welding Procedure Specification  
 WPS SMAW X65 Double Repair

|  |  |   |   |
|--|--|---|---|
| Applicable Codes and Specifications                  | API Standard 1104 20 <sup>th</sup> Edition   | Date: 06/22/2011  | Revision Date:  |
| Supporting PQR                                       | Procedure Qualification Record (PQR): X65 through Thickness Double Repair  |   |   |
| Process and Method                                   | Shielded Metal Arc Welding<br>-  | Repair Area Would be Explored and Excavated by Abrasive Grinding Disc   |   |
| Materials, Diameter, and Wall Thickness              | Manual<br>Materials:<br><input type="checkbox"/> API 5L X42, Grade B<br><input type="checkbox"/> API 5L X46, X52, X56, X60<br><input checked="" type="checkbox"/> API 5L X65<br><input type="checkbox"/> API 5L X70  | Diameter:<br>All Diameters  | Wall Thickness:<br><input type="checkbox"/> Under 0.188<br><input checked="" type="checkbox"/> 0.188 through 0.750<br><input type="checkbox"/> Over 0.750 |
| Joint Design   |   |   |   |
| Position of Pipe Axis                                | <input checked="" type="checkbox"/> Flat (1G) <input checked="" type="checkbox"/> Multiple (5G)<br><input checked="" type="checkbox"/> Horizontal (2G) <input checked="" type="checkbox"/> Inclined (6G)<br><input checked="" type="checkbox"/> Vertical (3G) <input checked="" type="checkbox"/> Fixed<br><input checked="" type="checkbox"/> Overhead (4G) <input type="checkbox"/> Rolled | Generic Bead Sequence $1/32'' - 1/16''$<br> |   |
| Minimum Number of Welders                            | One welder for OD < 16" NPS, two welders required for OD ≥ 16" NPS.  |   |   |
| Type & Removal of Lineup Clamp                       | None required. When used the requirements are<br>External - 50% of root bead must be completed before removal<br>Internal - 100% of root bead must be complete before removal  |   |   |
| Preheating: method, temperature, temperature control | Preheat to 300° F.<br>Heat using a gas torch, induction coils, or other approved method. Monitor temperature using tempil sticks, contact pyrometer, or infrared gun.  |   |   |

**Welding Procedure Specification  
WPS SMAW X65 Double Repair**

|   |  |                     |                              |                      |
|---|--|---------------------|------------------------------|----------------------|
| Post Weld Heat Treatment  | <input type="checkbox"/> Yes <input checked="" type="checkbox"/> No  | Time Temperature °F |                              |                      |
| Cleaning and/or Grinding  | <input checked="" type="checkbox"/> Hand Tools <input checked="" type="checkbox"/> Power Tools   |                     |                              |                      |
| Time Between Passes (mins)  | Root and Hot 1.5 Minutes. Time Between Hot and First Fill – 10 Max when wall thickness exceeds 0.500". All other passes within 15 Minutes. |                     |                              |                      |
| Welding Pass  | Root Bead (RB)   | Hot (H)             | Fills (F)                    | Cap (C)              |
| Welding Process   | SMAW   | SMAW                | SMAW                         | SMAW                 |
| Direction of Welding  | Vertical Down  | Vertical Down       | Vertical Down                | Vertical Down        |
| Polarity  | DCRP (+)   | DCRP (+)            | DCRP (+)                     | DCRP (+)             |
| Deposition Method   | Stringer/Weave   | Stringer/Weave      | Stringer/Weave               | Stringer/Weave       |
| AWS Specification   | A5.1   | A5.1                | A5.5                         | A5.5                 |
| AWS Classification  | E6010  | E6010               | E8010                        | E8010                |
| Electrode Diameter(s)   | 5/32   | 5/32                | 5/32                         | 5/32                 |
| Arc Voltage – Min (preferred) Max                                     | 18 - (22-28) - 34  | 18 - (22-28) - 34   | 18 - (22-28) - 34            | 18 - (22-28) - 34    |
| Amperage – Min (preferred) Max  | 90-(130-160)-200   | 90-(130-160)-200    | 90-(130-160)-200             | 90-(130-160)-200     |
| Travel Speed Range (inch/min)   | 4-18   | 4-18                | 4-18                         | 4-18                 |
| Minimum number of Passes  | Wall Thickness Range (in)  | Number of passes    |                              | Number of Cap Passes |
|   | < 0.188  | 3                   |                              | 1                    |
|   | ≥ 0.188 to 0.250   | 3                   |                              | 1                    |
|   | ≥ 0.250 to 0.500   | 4                   |                              | 1                    |
|   | ≥ 0.500 through 0.750  | 5                   |                              | 2                    |
|   | > .750   | 6                   |                              | 2                    |
| Notes   | Stripper beads are optional and do not count toward the minimum number of passes.  |                     |                              |                      |
| E7010 electrodes may be substituted for E6010 Electrodes for any pass |  |                     |                              |                      |
| Optional Electrode Diameters  |  |                     |                              |                      |
| Welding Pass  | RB,H,F,C   | RB,H,F,C            | H,F,C                        | F,C                  |
| Diameter  | 3/32   | 1/8                 | 5/32                         | 3/16                 |
| Arc Voltage – Min (preferred) Max                                     | 18-(20-35)-32  | 18-(20-25)-32       | 18-(22-28)-34                | 18-(22-28)-34        |
| Amperage – Min (preferred) Max  | 40-(50-80)-100   | 50-(90-120)-180     | 80-(130-160)-200             | 110-(160-200)-225    |
| Travel Speed (ipm)  | 4-18   | 4-18                | 4-18                         | 4-18                 |
| Submittal   | Author: Robert W Lawless   |                     | Title: Gas Standard Engineer |                      |
|   | Company/Organization:  |                     |                              | Date: 11/2/2011      |
| Approval  | Title  |                     | Name                         |                      |
|   | Gas Standard Engineer  |                     | Robert W. Lawless            |                      |
|   |  |                     |                              |                      |
|   |  |                     | Date                         |                      |
|   |  | 11/2/2011           |                              |                      |