

# SPECIFICATIONS

---

---

- **Owners:**                   Kenton County Fiscal Court and  
Northern Kentucky Water District
  
- **Description:**           Latonia Lakes Street and  
Water Main Reconstruction
  
- **Location:**               Latonia Lakes Area
  
- **Date:**                     March 2016
  
- **KY Labor Cabinet #: 059-H-00646-15-2**  
**Heavy/Highway**



**VIOX & VIOX**

Civil Engineers, Surveyors, and Landscape Architects

466 Erlanger Road • Erlanger, Kentucky 41018

Ph (859) 727-3293 • Fax (859) 727-8452 • [www.vioxinc.com](http://www.vioxinc.com)

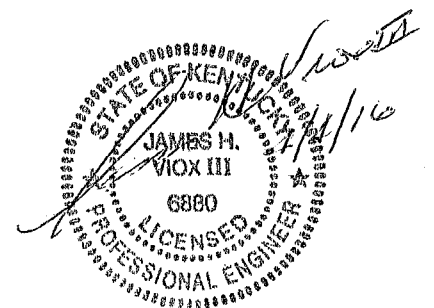

(This page left blank intentionally)

## TABLE OF CONTENTS

### BIDDING REQUIREMENTS

Notice to Bidders	00100-1 through 00100-2
Instructions to Bidders	00200-1 through 00200-11

### CONDITIONS OF THE CONTRACT

General Conditions	00700-1 through 00700-62
Supplementary Conditions to General Conditions	00800-1 through 00800-21
Kentucky Prevailing Wage Rates	00835-1 through 00835-12

### TECHNICAL SPECIFICATIONS

#### DIVISION 1 - GENERAL REQUIREMENTS

Summary of Work Pertaining to Street Constr.	01010-1 through 01010-3
Summary of Work Pertaining to Water Main Constr.	01015-1 through 01015-7
Measurement and Payment	
Part A - Pertaining to Street Construction	01025-1 through 01025-5
Measurement and Payment	
Part B - Pertaining to Water Main Construction	01025-6 through 01025-15
Schedule of Values	01026-1 through 01026-2
Project Coordination	01040-1 through 01040-2
Field Engineering	01050-1 through 01050-2
References	01090-1 through 01090-6
Preconstruction Conference	01210-1 through 01210-2
Progress Meetings	01220-1 through 01220-2
Construction Schedules	01310-1 through 01310-2
Shop Drawing Procedures	01340-1 through 01340-6
Construction Videotapes and Photographs	01380-1 through 01380-2
Testing Laboratory Services	01410-1 through 01410-3
Temporary Construction Facilities	01510-1 through 01510-2
Temporary Electricity and Lighting	01511-1 through 01511-2
Security	01540-1
Protection of the Work and Property	01541-1 through 01541-4
Access Roads and Parking Areas	01550-1 through 01550-2
Environmental Controls	01560-1 through 01560-7
Maintenance and Protection of Traffic	01570-1 through 01570-3
Transportation and Handling Products	01610-1 through 01610-3
Storage and Protection of Products	01611-1 through 01611-3
Cleaning	01710-1 through 01710-3
Record Documents	01720-1 through 01720-3

## DIVISION 2 - SITEWORK

Clearing & Grubbing	02100-1 through 02100-2
Earthwork, Grading and Backfilling	02200-1 through 02200-4
Rock Removal	02225-1
Slope Protection and Erosion Control	02300-1 through 02300-6
Bituminous Concrete Pavement	02400-1
Full Depth Reclamation	02410-1 through 02410-6
Pavement Striping	02425-1 through 02425-3
Storm Sewers	02500-1
Restoration - Seed	02700-1 through 02700-6
Restoration - Sod	02800-1 through 02800-6

### APPENDIX A

#### Bid Packet

(Kenton County Fiscal Court Request for Bid/Proposal Information, Bid Forms, Bid Quantity Notes, Bidder Qualifications Statement, Bidders Pre-Qualification Statement, Non Collusion Affidavit, Non-Resident Bidder Form)

### APPENDIX B

AIA Payment Application Forms (AIA-G702 & G703)

Change Order Form

Department of Labor Payroll Form (Sample)

Bid Bond (Sample)

### APPENDIX C

Standard Drawings

## **BIDDING REQUIREMENTS**

(This page left blank intentionally)

SECTION 00100

NOTICE TO BIDDERS

Project: **Latonia Lakes Street Reconstruction and Water Main Project**  
(Latonia Lakes Area)

Date/Time: Tuesday, March 15, 2016  
3:00 p.m. local time.

Sealed bids for the **Latonia Lakes Street Reconstruction and Water Main Project** will be received by the Kenton County Fiscal Court, until 3:00 p.m., local time on Tuesday, March 15, 2016, at which time the bids will be publicly opened and read.

This project includes all materials, labor, equipment, and installation necessary to complete the construction of the water main, storm sewer, pavement rehabilitation and all appurtenances.

Beginning February 25, 2016 Documents may be examined from 8:00 a.m. to 4 p.m. - Monday through Friday at the following locations:

Viox & Viox Inc.  
466 Erlanger Rd.  
Erlanger, KY 41018

Kenton County Public Works  
420 Independence Station Road  
Independence, KY 41051

Plans, Specifications, and Bid Documents shall be obtained from the official document distributor, Viox & Viox, Inc. located at 466 Erlanger Road, Erlanger, KY 41018, Telephone number - (859) 727-3293, upon payment of the nonrefundable cost of \$125.00 per set (shipping and handling costs not included), payable to Viox & Viox, Inc. Neither the OWNER nor the ENGINEER will be responsible for full or partial sets of Bidding Documents, including any addenda, obtained from other sources.

**This project is subject to the Prevailing Wage Rates as determined by the Kentucky Department of Labor.**

**Attention is called to the CONTRACTOR Qualification Requirements which include a current Certificate of Eligibility from the Kentucky Transportation Cabinet at the time of bid.**

CONTRACTORS shall register with Viox & Viox, Inc. to qualify as a bidder. No substitution of CONTRACTORS shall occur without change of registration.

Each sealed bid shall be accompanied by either a cashier's check or satisfactory bid bond, in a sum which is not less than five (5%) percent of the aggregate amount of the bid, payable to the Kenton County Fiscal Court.

Successful bidder will be required to execute and to provide construction contract security in an amount not less than one hundred percent of the bid.

Bidders shall provide bid security and proof of qualifications to perform the Work as described in the Instructions to Bidders. Bidders must comply with all statutory requirements in accordance with the Instructions to Bidders.

All bids must be made on the required Bid Form in the Appendix (the County requires 1 original and 3 copies of the bid/proposal). The Bid Form shall not be altered in any way.

The Kenton County Fiscal Court reserves the right to reject the bids which do not meet the requirements as noted in the Specifications or if the project low bid is over the funded budget.

Bids shall remain subject to acceptance for 90 days after the day of bid opening or for such longer period of time to which a Bidder may agree in writing upon request of the Owner. If a contract is to be awarded, the Owner will give the successful Bidder a Notice of Award during the period of time during which the successful Bidder's bid remains subject to acceptance.

Holly Hill, Buyer  
Kenton County Fiscal Court

++END OF SECTION++



## SECTION 00200

### INSTRUCTIONS TO BIDDERS

#### 1.1 PRE-QUALIFICATION OF BIDDERS

- A. See Division 100, Section 102, 102.01 of the Kentucky Standard Specification for Road and Bridge Construction, most current edition, for specifics on pre-qualification of bidders for this project.
- B. If certification from KYTC does not exist for a particular CONTRACTOR activity, then the above statement shall not apply for that particular activity (i.e. landscaping).
- C. Bid proposals submitted by CONTRACTORS that do not meet the criteria above will not be considered.

#### 1.2 PRE-BID CONFERENCE

- A. A Pre-bid conference will be held for this project. Refer to the Notice to Bidders for information on date, time, and any other requirements.

#### 1.3 EXAMINATION OF BIDDING DOCUMENTS, OTHER RELATED DATA AND SITE

- A. It is the responsibility of Bidder, before submitting a Bid to:
  - 1. Thoroughly examine and carefully study the Bidding Documents, including any Addenda and the other related data identified in the Bidding Documents;
  - 2. Visit the Site and become familiar with and satisfy Bidder as to the general, local and Site conditions that may affect cost, progress and performance of the Work;
  - 3. Become familiar with and satisfy Bidder as to all federal, state and local Laws and Regulations that may affect cost, progress and performance of the Work;
  - 4. Carefully study all reports of explorations and tests of subsurface conditions at or contiguous to the Site and all drawings of physical conditions in or relating to existing surface or subsurface structures at or contiguous to the Site (except Underground Facilities) which have been identified in the Supplementary Conditions as provided in paragraph 4.02 of the General Conditions;

5. Obtain and carefully study (or assume responsibility for having done so) all examinations, investigations, explorations, tests, studies, and data concerning conditions (surface, subsurface and Underground Facilities ) at or contiguous to the Site which may affect cost, progress or performance of the Work or which relate to any aspect of the means, methods, techniques, sequences and procedures of construction to be employed by Bidder, including any specific means, methods, techniques, sequences and procedures of construction expressly required by Bidding Documents, and safety precautions and programs incident thereto;
6. Agree at the time of submitting its Bid that no further examinations, investigations, explorations, tests, studies, or data are necessary for the determination of its Bid for the performance of the Work at the price bid and within the times and in accordance with the other terms and conditions of the Bidding Documents;
7. Become aware of the general nature of work (if any) to be performed by OWNER and others at the site that relates to the Work as indicated in the Bidding Documents;
8. Correlate the information known to Bidder, information and observations obtained from visits to the Site, reports and drawings identified in the Bidding Documents, and all additional examinations, investigations, explorations, tests, studies and data with the Bidding Documents;
9. Promptly give OWNER written notice of all conflicts, errors, ambiguities or discrepancies that Bidder discovers in the Bidding Documents and confirm that the written resolution thereof by OWNER is acceptable to Bidder; and
10. Determine that the Bidding Documents are generally sufficient to indicate and convey understanding of all terms and conditions for the performance of the Work.

#### 1.4 INTERPRETATIONS OF BID PROPOSAL & ADDENDA

- A. All questions about the true meaning or intent of any part of the plans, specifications, or other proposed contract documents, shall be submitted in writing to the ENGINEER, Viox and Viox, Inc.; Civil ENGINEERS, 466 Erlanger Road, Erlanger, Kentucky.
- B. In order to receive consideration, questions must be received by the ENGINEER, at least three days prior to the date for the Bid opening. The person making the request will be responsible for its prompt delivery.
- C. Any interpretations or clarifications of the contract documents considered necessary by the OWNER or ENGINEER will be issued by addenda and mailed, faxed or delivered to all parties recorded by the ENGINEER as having received

the Bidding documents for receipt not later than two days prior to the date of the opening of bids.

- D. Only questions answered by addenda will be binding. Oral and other interpretations or clarification will be without legal effect.
- E. OWNER will not be responsible for explanations or interpretations of the proposed documents except as issued in accordance herewith.

1.5 PREPARATION OF BID

- A. A Bid Proposal must be made on the Bid Form provided in the back of the Specification Book.
- B. All blanks in the Bid Proposal form shall be completed by printing in ink or by typewriter. A bid price shall be indicated in numerals for each Bid Item listed.
- C. A bid price shall be indicated in numerals for each Bid Item listed. No partial bids will be accepted.
- D. The bid proposal must be signed in the locations indicated on the bid form.
- E. The Bid Proposal shall contain copies of the Acknowledgement of Receipt for all Addenda issued for the project.

1.6 BID PROPOSAL GUARANTY

- A. As set out in the Notice to Bidders, the bidder shall be required to furnish bid guaranty in the amount of not less than five percent (5%) of the bid. The OWNER will reject and will not read any Bid Proposal that is not accompanied by a guarantee in the form of a cashier's check, certified check, or a bid bond in the amount specified above. The guaranty should be made payable to "Kenton County Fiscal Court".
- B. Bid Bond shall be an equivalent instrument meeting the minimum requirements of the Bid Bond sample, which can be found in Appendix B. Bid Bond shall be issued by a surety meeting the requirements of Paragraphs 5.01 and 5.02 of the General Conditions.

1.7 SUBMITTAL OF BID PROPOSAL

- A. The entire Bid Proposal shall be submitted no later than the date and time prescribed and at the place indicated in the Notice to Bidders.
- B. A total of four (4) bid proposals shall be submitted: One (1) complete and executed bid proposal, and three (3) photo copies of the complete and executed bid proposal. A complete bid proposal shall contain the following items: completed and signed Bid Quantity Forms, Bid Guaranty, Bidders Pre-Qualification Statement, Non-collusion Affidavit. The Bid Quantity Notes and Bid Quantity Measurement and Payment Sections shall also be submitted as part of the bid proposal, to acknowledge that the contractor has read these items.
- C. The Bid Proposal shall be enclosed in a sealed envelope and clearly labeled with the project title, name and address of the bidder, and the date and time of opening, so as to guard against premature opening of any bid.
- D. If the Bid is sent by mail or other delivery system, the sealed envelope containing the Bid shall be enclosed in a separate envelope plainly marked on the outside with the notation "Bid Enclosed for: "Latonia Lakes Street Reconstruction and Water Main Replacement Project". Bids shall be addressed to:

HOLLY HILL, BUYER  
P.O. Box 792  
303 COURT STREET  
ROOM 207  
COVINGTON, KENTUCKY 41012-0792

- E. Bidder shall assume full responsibility for timely delivery at the location designated for receipt of Bid Proposals. Bid Proposals received after the time and date for receipt of Bid Proposals will be returned unopened. Telephone or facsimile bids are invalid and will not receive consideration.

1.9 DISQUALIFIED BIDDERS

- A. Any bidder who has defaulted on any contract with the Kenton County Fiscal Court within the past three years shall not be qualified for any portion of the work.

1.9 MODIFICATION OR WITHDRAWAL OF BID

- A. Withdrawal prior to bid opening:
  - 1. A bid may be withdrawn either in person or by telegraphic or written request at any time prior to the scheduled time for closing the receipt of bids.

- B. Modification prior to bid opening:
  - 1. If a bidder wishes to modify its bid, bidder must withdraw its initial bid and submit a new bid.
- C. If within 24 hours after Bids are opened, any Bidder files a duly signed written notice with the OWNER and promptly thereafter demonstrates to the reasonable satisfaction of the OWNER that there was material and substantial mistake in the preparation of its Bid, that Bidder may withdrawal its Bid and the Bid Security will be returned. If a CONTRACTOR chooses to withdrawal its bid, more than 24 hours after the Bids are opened, the Bid Security will not be returned.

1.10 BASIS OF BIDS; COMPARISON OF BIDS

- A. The Bid consists of a series of lump sums with unit price items:
  - 1. For each lump sum item on the Bid Form, Bidder shall enter the lump sum Bid in the spaces provided on the Bid Form.
  - 2. For each unit price item on the Bid Form, Bidder shall enter the unit price Bid, and shall enter the computation of the respective quantity times the Bidder's unit price for that item in the spaces provided on the Bid Form.
  - 3. Bidder shall compute and enter the total of all lump sum items and the products of quantity and unit price Bid for each unit price item in the space provided on the Bid Form. This amount shall be considered as the Total Bid Amount.
  - 4. For determination of the apparent low Bidder, Bids will be compared on the basis of the Total Bid Amount, which is the sum of the Total Base Bid Price plus any and all Add Alternate items as may be selected by the OWNER.
- B. Discrepancies between the multiplication of units of Work and unit prices will be resolved in favor of the unit prices. Discrepancies between the indicated sum of any column of figures and the correct sum thereof will be resolved in favor of the correct sum.
- C. In case of discrepancy between the bid price in words and in figures in the Bid Proposal, the price words will control.

1.11 REJECTION OF BID PROPOSALS

- A. Bid Proposals that contain any omission, condition, or limitation, or that show any other irregularity of any kind may be rejected as informal.

1.12 AWARD OF CONTRACT

- A. The contract will be awarded to the lowest responsive and responsible bidder as soon as practicable after the opening of bids.

1.13 COMMENCEMENT AND COMPLETION OF WORK

- A. The CONTRACTOR shall commence work on a date as specified in the bid packet, the contract.
- B. The CONTRACTOR shall have the following days to achieve milestones of substantial completion, and final payment.
  - 1. Milestone No. 1 – The Work shall be substantially completed on or before April 30, 2017. Substantial completion shall consist of all pavement, storm sewer, and all other required appurtenances to allow the road to be used for its purpose in a safe manner.
  - 2. Milestone No. 2 – The work shall be completed and ready for final payment in accordance with the General Conditions, Section 0070, Paragraph 14.07 on or before June 30, 2017.

1.14 FAILURE TO COMPLETE WORK ON TIME

- A. Should the CONTRACTOR fail to complete the work within the time specified in the Contract, there will be deducted by the OWNER “Liquidated Damages” in the amount per day as set below. The amount of “liquidated Damages” shall in no event be considered a penalty or otherwise than an agreed “Liquidated and adjustment damage” to reimburse by reason the CONTRACTOR’S failure to complete the work within the time specified.
- B. A log indicating working days will be kept jointly by the COUNTY and the CONTRACTOR.
- C. Liquidated damages shall be per the table below:

ORIGINAL CONTRACT AMOUNT		DAILY CHARGE
(FROM)	(TO AND INCLUDING)	
0.00	100,000.00	250.00
100,000.01	500,000.00	750.00
500,000.01	1,000,000.00	1,650.00
1,000,000.01	5,000,000.00	2,400.00
5,000,000.01	10,000,000.00	3,250.00
10,000,000.01	20,000,000.00	4,000.00
20,000,000.01	or more	4,750.00

1.15 CONTRACT DRAWINGS & SPECIFICATIONS:

- A. Three (3) sets of contract drawings and specifications will be furnished to the successful bidder without charge. Additional sets will be furnished upon request at the cost of reproduction.

1.16 EXECUTION OF CONTRACT

- A. The Construction Contract and performance bond shall be executed within the time specified in the proposal, and in at least three (3) copies.

1.17 ASSIGNMENT OF CONTRACT

- A. The CONTRACTOR will not be permitted to assign his Contract or any portion thereof, nor may any monies due that become due there under, without the written approval of the OWNER.

1.18 SUBLETTING CONTRACT

- A. The CONTRACTOR shall not sublet, sell, transfer, assign, or otherwise dispose of any portion of the Contract to any individual, co-partnership, or corporation without the proper written consent of the OWNER.

1.19 SEPARATE CONTRACTS

- A. The OWNER reserves the right to let other contracts in connection with the work. The CONTRACTOR shall afford other CONTRACTORS reasonable opportunity for ingress and egress and storage of their material and the execution of their work, and shall properly connect and coordinate his work with theirs. The respective right of various interests shall be established by the ENGINEER to secure proper completion of the various portions of the work.

1.20 CONTRACT SECURITY OR PERFORMANCE BOND

- A. The CONTRACTOR will be required to furnish a surety bond executed by a surety company duly authorized to do business in the state in which the work is to be performed in an amount at least equal to 100% of the contract price, as security for the faithful performance of this contract and as security for the payment of all persons performing labor and furnishing materials in connection with this contract.

1.21 INSURANCE, CONTRACTOR'S COVERAGE AND CANCELLATION PROVISION

- A. See Section 00700, General Conditions, Article 5, and the corresponding Supplementary Conditions, Section 0800.

1.22 PREVAILING WAGE RATES

- A. The prevailing rate of wages to be paid laborers, workmen and mechanics have been determined and fixed by the Department of Industrial Relations of the Commonwealth of Kentucky and CONTRACTOR shall so conform.

1.23 NON-REBATE OF WAGES

- A. The CONTRACTOR shall comply with the regulations, ruling and interpretations of the Secretary of Labor of the United States pursuant to the Anti-Kickback Act (Title 18, U.S.C. Sec. 874 and Title 40, U.S.C., Sec. 276c) which makes it unlawful to induce any person employed in the construction or repair of public buildings or public works to give up any part of the compensation to which he is entitled under his Contract of employment; and the CONTRACTOR agrees to insert a like provision in all subcontracts hereunder.

1.24 HOURS OF WORK AND RECORDS

- A. The CONTRACTOR shall conform in every respect to all provisions of the Kentucky Revised Statutes 337.510 to 337.990 relative to wages and hours. This shall include full and accurate payroll records covering all disbursements of wages to employees as covered in KRS 337.520. Wages will be defined in Section 00835.

- B. Hours of work shall be as set out in KRS 337.540 that is not more than eight (8) hours in one calendar day, nor more than forty (40) hours in one week except in case of emergency caused by fire, flood, or damage to life or property.

Any laborer, workman, mechanic, helper, assistant, or apprentice working in excess of 8 hours per day or 40 hours in one week except in case of emergency shall be paid not less than 1 1/2 times the "Prevailing Wage Rate" as set out hereinafter.

- C. Additional information concerning wages and hours are covered in General Conditions, Section 00700, and Supplementary Conditions, Section 00800.

1.25 EXTRA WORK

- A. Any departures from the original contract will be made as provided in the General Conditions, Section 00700, under "Extra Work".

1.26 SECOND HAND SALVAGED MATERIALS

- A. The use of second hand and/or salvaged materials will not be permitted unless specifically provided for in the specifications.



1.27 ALTERNATES

- A. Alternates if any are defined in the bid packet.

1.28 MATERIALS AND EQUIPMENT REQUIREMENTS IN BID PROPOSAL

- A. It is the intention of the specific technical specifications to specify standard materials and equipment. However, when space is provided in the Proposal the bidders shall specify the equipment and materials which they propose to use in the contemplated project, and the OWNER may declare a bid irregular wherein the equipment and materials are not specifically named by the bidder.

1.29 "OR EQUAL" CLAUSE

- A. See Division 0700, General Conditions, Article 6, CONTRACTOR'S Responsibilities, 6.05, Substitutes and "Or-Equals".

1.30 SPECIFIC BRANDS, MAKES, OR MANUFACTURE

- A. Wherever in the specifications a certain brand, make, or manufacture is set out, it is intended to denote the quality standard of the article desired, but unless otherwise noted does not restrict bidders to the specific brand, make or manufacture; it is to set forth and convey to the prospective bidder the general style, type, character, and quality of the article desired.

1.31 PAYMENT FOR MATERIALS STORED AT SITE OF PROJECT

- A. Payment for materials or equipment stored at the site of the project may be allowed by the OWNER to the extent of 90% of the cost of such materials or equipment upon specific recommendation of the ENGINEER. Materials or equipment eligible for advance payment prior to being incorporated in the work or prior to installation are cast/ductile iron pipe, valves, special cast/ductile iron fittings, structural steel, machinery, equipment, or such other items as in the opinion of the ENGINEER are eligible. It is solely the CONTRACTOR'S responsibility to secure the stored items.

1.32 EMPLOYMENT, QUALIFICATIONS

- A. No person under the age of sixteen (16) years, and no convict labor shall be employed to perform any work under this contract. No person whose age or physical condition is such as to make his employment dangerous to his health or safety or to the health and safety of others shall be employed to perform any work under this contract, provided that this shall not operate against the employment of physically handicapped persons, otherwise employable, where such persons may be safely assigned to work which they can ably perform.
- B. There shall be no discrimination because of race, creed, color, or political affiliations in the employment of persons for work under this contract.

1.33 EMPLOYMENT SERVICES & LABOR PREFERENCES

- A. With respect to all skilled, semi-skilled, and unskilled workers employed to perform work on the project, preference in employment shall be given first to persons who reside in the city in which the work is to be performed, and second to persons residing in the county in which the work is to be performed.

1.34 PAYMENT OF EMPLOYEES

- A. The CONTRACTOR and each of his SUB-CONTRACTORS shall pay each of his employees engaged in work on the project in full (less deductions made mandatory by law) in cash and not less often than as required by Federal or State law.

1.35 MATERIALS, CONVICT MADE

- A. No material manufactured or produced in a penal or correctional institution shall be incorporated in the project under this contract.

1.36 MATERIALS, DOMESTIC & FOREIGN

- A. Only such unmanufactured articles, materials, and supplies as have been mined or produced in the United States of America, and only such manufactured articles, materials, and supplies as have been manufactured in the United States of America substantially all from articles, materials, or supplies, mined, produced, or manufactured as the case may be in the United States of America, shall be employed under this contract in the construction of the project.

1.37 CONSTRUCTION PAYROLL RECORDS & REPORTS

- A. The CONTRACTOR shall furnish the OWNER with substantial proof that all payrolls for services rendered and invoices for materials supplied have been duly paid as herein required, and such other data as the OWNER may require.
- B. In connection with all lump sum contracts, the CONTRACTOR shall furnish the ENGINEER a suitable detailed breakdown on which to base partial payment estimates.
- C. When so required, the CONTRACTOR shall furnish and keep current a suitable progress chart or schedule showing the estimated and actual progress on the work. The progress chart or schedule shall be subject to the approval of the ENGINEER.
- D. The CONTRACTOR shall furnish all the necessary information for, and assist in the preparation of, and/or prepare the partial payment estimates on forms approved by the ENGINEER.

- E. The ENGINEER or his authorized representatives and agents shall be permitted to inspect all payrolls, records of personnel, invoices of materials, and other relevant data and records.

1.38 PARTIAL PAYMENT ESTIMATES

- A. Partial Payments (also known as progress payments) shall be made in accordance with the details set out hereinafter under General Conditions, Section 00700, General Conditions, and Section 00800, Supplemental Conditions, Article 14.

1.39 CONTRACTOR'S ACCOUNTS

- A. The CONTRACTOR shall pay for all services (including transportation and utility services, for all materials, tools, and other expendable equipment, and to each of the SUB-CONTRACTORS) as per the time frame and respective amounts as specified in the contract for each of these items required to complete the project. The COUNTY shall not be held liable for any late payments or fines incurred due to late payments made by the CONTRACTOR for these services.

1.40 FINAL PAYMENT

- A. Final payment shall be made in accordance with the details set out hereinafter under General Conditions, Section 00700.

++END OF SECTION++

(This page left blank intentionally)

## **CONDITIONS OF THE CONTRACT**

(This page left blank intentionally)

This document has important legal consequences; consultation with an attorney is encouraged with respect to its use or modification. This document should be adapted to the particular circumstances of the contemplated Project and the controlling Laws and Regulations.

# STANDARD GENERAL CONDITIONS OF THE CONSTRUCTION CONTRACT

Prepared by

**ENGINEERS JOINT CONTRACT DOCUMENTS COMMITTEE**

and

Issued and Published Jointly by



AMERICAN COUNCIL OF ENGINEERING COMPANIES

ASSOCIATED GENERAL CONTRACTORS OF AMERICA

AMERICAN SOCIETY OF CIVIL ENGINEERS

PROFESSIONAL ENGINEERS IN PRIVATE PRACTICE  
*A Practice Division of the*  
NATIONAL SOCIETY OF PROFESSIONAL ENGINEERS

Endorsed by



CONSTRUCTION SPECIFICATIONS INSTITUTE

These General Conditions have been prepared for use with the Suggested Forms of Agreement Between Owner and Contractor (EJCDC C-520 or C-525, 2007 Editions). Their provisions are interrelated and a change in one may necessitate a change in the other. Comments concerning their usage are contained in the Narrative Guide to the EJCDC Construction Documents (EJCDC C-001, 2007 Edition). For guidance in the preparation of Supplementary Conditions, see Guide to the Preparation of Supplementary Conditions (EJCDC C-800, 2007 Edition).

Copyright © 2007 National Society of Professional Engineers  
1420 King Street, Alexandria, VA 22314-2794  
(703) 684-2882  
[www.nspe.org](http://www.nspe.org)

American Council of Engineering Companies  
1015 15th Street N.W., Washington, DC 20005  
(202) 347-7474  
[www.acec.org](http://www.acec.org)

American Society of Civil Engineers  
1801 Alexander Bell Drive, Reston, VA 20191-4400  
(800) 548-2723  
[www.asce.org](http://www.asce.org)

Associated General Contractors of America  
2300 Wilson Boulevard, Suite 400, Arlington, VA 22201-3308  
(703) 548-3118  
[www.agc.org](http://www.agc.org)

The copyright for this EJCDC document is owned jointly by the four EJCDC sponsoring organizations and held in trust for their benefit by NSPE.



# STANDARD GENERAL CONDITIONS OF THE CONSTRUCTION CONTRACT

## TABLE OF CONTENTS

	Page
Article 1 – Definitions and Terminology.....	1
1.01 Defined Terms.....	1
1.02 Terminology.....	5
Article 2 – Preliminary Matters.....	6
2.01 Delivery of Bonds and Evidence of Insurance.....	6
2.02 Copies of Documents.....	6
2.03 Commencement of Contract Times; Notice to Proceed.....	6
2.04 Starting the Work.....	7
2.05 Before Starting Construction.....	7
2.06 Preconstruction Conference; Designation of Authorized Representatives.....	7
2.07 Initial Acceptance of Schedules.....	7
Article 3 – Contract Documents: Intent, Amending, Reuse.....	8
3.01 Intent.....	8
3.02 Reference Standards.....	8
3.03 Reporting and Resolving Discrepancies.....	9
3.04 Amending and Supplementing Contract Documents.....	9
3.05 Reuse of Documents.....	10
3.06 Electronic Data.....	10
Article 4 – Availability of Lands; Subsurface and Physical Conditions; Hazardous Environmental Conditions; Reference Points.....	11
4.01 Availability of Lands.....	11
4.02 Subsurface and Physical Conditions.....	11
4.03 Differing Subsurface or Physical Conditions.....	12
4.04 Underground Facilities.....	13
4.05 Reference Points.....	14
4.06 Hazardous Environmental Condition at Site.....	14
Article 5 – Bonds and Insurance.....	16
5.01 Performance, Payment, and Other Bonds.....	16
5.02 Licensed Sureties and Insurers.....	16
5.03 Certificates of Insurance.....	17
5.04 Contractor’s Insurance.....	17
5.05 Owner’s Liability Insurance.....	19
5.06 Property Insurance.....	19
5.07 Waiver of Rights.....	20
5.08 Receipt and Application of Insurance Proceeds.....	21

5.09	Acceptance of Bonds and Insurance; Option to Replace .....	21
5.10	Partial Utilization, Acknowledgment of Property Insurer .....	22
Article 6 – Contractor’s Responsibilities.....		22
6.01	Supervision and Superintendence .....	22
6.02	Labor; Working Hours .....	22
6.03	Services, Materials, and Equipment .....	22
6.04	Progress Schedule .....	23
6.05	Substitutes and “Or-Equals” .....	23
6.06	Concerning Subcontractors, Suppliers, and Others .....	25
6.07	Patent Fees and Royalties.....	27
6.08	Permits .....	27
6.09	Laws and Regulations .....	28
6.10	Taxes.....	28
6.11	Use of Site and Other Areas.....	28
6.12	Record Documents .....	29
6.13	Safety and Protection.....	29
6.14	Safety Representative .....	30
6.15	Hazard Communication Programs.....	30
6.16	Emergencies .....	30
6.17	Shop Drawings and Samples .....	31
6.18	Continuing the Work.....	32
6.19	Contractor’s General Warranty and Guarantee .....	33
6.20	Indemnification .....	33
6.21	Delegation of Professional Design Services .....	34
Article 7 – Other Work at the Site .....		35
7.01	Related Work at Site .....	35
7.02	Coordination.....	35
7.03	Legal Relationships .....	36
Article 8 – Owner’s Responsibilities.....		36
8.01	Communications to Contractor .....	36
8.02	Replacement of Engineer .....	36
8.03	Furnish Data .....	36
8.04	Pay When Due.....	36
8.05	Lands and Easements; Reports and Tests.....	36
8.06	Insurance.....	36
8.07	Change Orders .....	37
8.08	Inspections, Tests, and Approvals.....	37
8.09	Limitations on Owner’s Responsibilities.....	37
8.10	Undisclosed Hazardous Environmental Condition .....	37
8.11	Evidence of Financial Arrangements.....	37
8.12	Compliance with Safety Program .....	37
Article 9 – Engineer’s Status During Construction.....		37
9.01	Owner’s Representative .....	37

9.02	Visits to Site .....	37
9.03	Project Representative.....	38
9.04	Authorized Variations in Work.....	38
9.05	Rejecting Defective Work.....	38
9.06	Shop Drawings, Change Orders and Payments .....	39
9.07	Determinations for Unit Price Work.....	39
9.08	Decisions on Requirements of Contract Documents and Acceptability of Work .....	39
9.09	Limitations on Engineer's Authority and Responsibilities .....	39
9.10	Compliance with Safety Program .....	40
Article 10 – Changes in the Work; Claims.....		40
10.01	Authorized Changes in the Work.....	40
10.02	Unauthorized Changes in the Work.....	41
10.03	Execution of Change Orders .....	41
10.04	Notification to Surety .....	41
10.05	Claims.....	41
Article 11 – Cost of the Work; Allowances; Unit Price Work .....		42
11.01	Cost of the Work .....	42
11.02	Allowances .....	45
11.03	Unit Price Work .....	45
Article 12 – Change of Contract Price; Change of Contract Times.....		46
12.01	Change of Contract Price .....	46
12.02	Change of Contract Times .....	47
12.03	Delays .....	47
Article 13 – Tests and Inspections; Correction, Removal or Acceptance of Defective Work.....		48
13.01	Notice of Defects.....	48
13.02	Access to Work .....	48
13.03	Tests and Inspections .....	49
13.04	Uncovering Work.....	49
13.05	Owner May Stop the Work .....	50
13.06	Correction or Removal of Defective Work .....	50
13.07	Correction Period .....	50
13.08	Acceptance of Defective Work.....	51
13.09	Owner May Correct Defective Work.....	52
Article 14 – Payments to Contractor and Completion .....		52
14.01	Schedule of Values.....	52
14.02	Progress Payments.....	52
14.03	Contractor's Warranty of Title.....	55
14.04	Substantial Completion.....	55
14.05	Partial Utilization .....	56
14.06	Final Inspection .....	57
14.07	Final Payment.....	57
14.08	Final Completion Delayed .....	58

14.09 Waiver of Claims .....	58
Article 15 – Suspension of Work and Termination.....	59
15.01 Owner May Suspend Work.....	59
15.02 Owner May Terminate for Cause.....	59
15.03 Owner May Terminate For Convenience .....	60
15.04 Contractor May Stop Work or Terminate.....	60
Article 16 – Dispute Resolution .....	61
16.01 Methods and Procedures .....	61
Article 17 – Miscellaneous .....	61
17.01 Giving Notice .....	61
17.02 Computation of Times .....	62
17.03 Cumulative Remedies .....	62
17.04 Survival of Obligations .....	62
17.05 Controlling Law .....	62
17.06 Headings .....	62

## ARTICLE 1 – DEFINITIONS AND TERMINOLOGY

### 1.01 *Defined Terms*

- A. Wherever used in the Bidding Requirements or Contract Documents and printed with initial capital letters, the terms listed below will have the meanings indicated which are applicable to both the singular and plural thereof. In addition to terms specifically defined, terms with initial capital letters in the Contract Documents include references to identified articles and paragraphs, and the titles of other documents or forms.
1. *Addenda*—Written or graphic instruments issued prior to the opening of Bids which clarify, correct, or change the Bidding Requirements or the proposed Contract Documents.
  2. *Agreement*—The written instrument which is evidence of the agreement between Owner and Contractor covering the Work.
  3. *Application for Payment*—The form acceptable to Engineer which is to be used by Contractor during the course of the Work in requesting progress or final payments and which is to be accompanied by such supporting documentation as is required by the Contract Documents.
  4. *Asbestos*—Any material that contains more than one percent asbestos and is friable or is releasing asbestos fibers into the air above current action levels established by the United States Occupational Safety and Health Administration.
  5. *Bid*—The offer or proposal of a Bidder submitted on the prescribed form setting forth the prices for the Work to be performed.
  6. *Bidder*—The individual or entity who submits a Bid directly to Owner.
  7. *Bidding Documents*—The Bidding Requirements and the proposed Contract Documents (including all Addenda).
  8. *Bidding Requirements*—The advertisement or invitation to bid, Instructions to Bidders, Bid security of acceptable form, if any, and the Bid Form with any supplements.
  9. *Change Order*—A document recommended by Engineer which is signed by Contractor and Owner and authorizes an addition, deletion, or revision in the Work or an adjustment in the Contract Price or the Contract Times, issued on or after the Effective Date of the Agreement.
  10. *Claim*—A demand or assertion by Owner or Contractor seeking an adjustment of Contract Price or Contract Times, or both, or other relief with respect to the terms of the Contract. A demand for money or services by a third party is not a Claim.
  11. *Contract*—The entire and integrated written agreement between the Owner and Contractor concerning the Work. The Contract supersedes prior negotiations, representations, or agreements, whether written or oral.

12. *Contract Documents*—Those items so designated in the Agreement. Only printed or hard copies of the items listed in the Agreement are Contract Documents. Approved Shop Drawings, other Contractor submittals, and the reports and drawings of subsurface and physical conditions are not Contract Documents.
13. *Contract Price*—The moneys payable by Owner to Contractor for completion of the Work in accordance with the Contract Documents as stated in the Agreement (subject to the provisions of Paragraph 11.03 in the case of Unit Price Work).
14. *Contract Times*—The number of days or the dates stated in the Agreement to: (i) achieve Milestones, if any; (ii) achieve Substantial Completion; and (iii) complete the Work so that it is ready for final payment as evidenced by Engineer's written recommendation of final payment.
15. *Contractor*—The individual or entity with whom Owner has entered into the Agreement.
16. *Cost of the Work*—See Paragraph 11.01 for definition.
17. *Drawings*—That part of the Contract Documents prepared or approved by Engineer which graphically shows the scope, extent, and character of the Work to be performed by Contractor. Shop Drawings and other Contractor submittals are not Drawings as so defined.
18. *Effective Date of the Agreement*—The date indicated in the Agreement on which it becomes effective, but if no such date is indicated, it means the date on which the Agreement is signed and delivered by the last of the two parties to sign and deliver.
19. *Engineer*—The individual or entity named as such in the Agreement.
20. *Field Order*—A written order issued by Engineer which requires minor changes in the Work but which does not involve a change in the Contract Price or the Contract Times.
21. *General Requirements*—Sections of Division 1 of the Specifications.
22. *Hazardous Environmental Condition*—The presence at the Site of Asbestos, PCBs, Petroleum, Hazardous Waste, or Radioactive Material in such quantities or circumstances that may present a substantial danger to persons or property exposed thereto.
23. *Hazardous Waste*—The term Hazardous Waste shall have the meaning provided in Section 1004 of the Solid Waste Disposal Act (42 USC Section 6903) as amended from time to time.
24. *Laws and Regulations; Laws or Regulations*—Any and all applicable laws, rules, regulations, ordinances, codes, and orders of any and all governmental bodies, agencies, authorities, and courts having jurisdiction.
25. *Liens*—Charges, security interests, or encumbrances upon Project funds, real property, or personal property.
26. *Milestone*—A principal event specified in the Contract Documents relating to an intermediate completion date or time prior to Substantial Completion of all the Work.

27. *Notice of Award*—The written notice by Owner to the Successful Bidder stating that upon timely compliance by the Successful Bidder with the conditions precedent listed therein, Owner will sign and deliver the Agreement.
28. *Notice to Proceed*—A written notice given by Owner to Contractor fixing the date on which the Contract Times will commence to run and on which Contractor shall start to perform the Work under the Contract Documents.
29. *Owner*—The individual or entity with whom Contractor has entered into the Agreement and for whom the Work is to be performed.
30. *PCBs*—Polychlorinated biphenyls.
31. *Petroleum*—Petroleum, including crude oil or any fraction thereof which is liquid at standard conditions of temperature and pressure (60 degrees Fahrenheit and 14.7 pounds per square inch absolute), such as oil, petroleum, fuel oil, oil sludge, oil refuse, gasoline, kerosene, and oil mixed with other non-Hazardous Waste and crude oils.
32. *Progress Schedule*—A schedule, prepared and maintained by Contractor, describing the sequence and duration of the activities comprising the Contractor's plan to accomplish the Work within the Contract Times.
33. *Project*—The total construction of which the Work to be performed under the Contract Documents may be the whole, or a part.
34. *Project Manual*—The bound documentary information prepared for bidding and constructing the Work. A listing of the contents of the Project Manual, which may be bound in one or more volumes, is contained in the table(s) of contents.
35. *Radioactive Material*—Source, special nuclear, or byproduct material as defined by the Atomic Energy Act of 1954 (42 USC Section 2011 et seq.) as amended from time to time.
36. *Resident Project Representative*—The authorized representative of Engineer who may be assigned to the Site or any part thereof.
37. *Samples*—Physical examples of materials, equipment, or workmanship that are representative of some portion of the Work and which establish the standards by which such portion of the Work will be judged.
38. *Schedule of Submittals*—A schedule, prepared and maintained by Contractor, of required submittals and the time requirements to support scheduled performance of related construction activities.
39. *Schedule of Values*—A schedule, prepared and maintained by Contractor, allocating portions of the Contract Price to various portions of the Work and used as the basis for reviewing Contractor's Applications for Payment.

40. *Shop Drawings*—All drawings, diagrams, illustrations, schedules, and other data or information which are specifically prepared or assembled by or for Contractor and submitted by Contractor to illustrate some portion of the Work.
41. *Site*—Lands or areas indicated in the Contract Documents as being furnished by Owner upon which the Work is to be performed, including rights-of-way and easements for access thereto, and such other lands furnished by Owner which are designated for the use of Contractor.
42. *Specifications*—That part of the Contract Documents consisting of written requirements for materials, equipment, systems, standards and workmanship as applied to the Work, and certain administrative requirements and procedural matters applicable thereto.
43. *Subcontractor*—An individual or entity having a direct contract with Contractor or with any other Subcontractor for the performance of a part of the Work at the Site.
44. *Substantial Completion*—The time at which the Work (or a specified part thereof) has progressed to the point where, in the opinion of Engineer, the Work (or a specified part thereof) is sufficiently complete, in accordance with the Contract Documents, so that the Work (or a specified part thereof) can be utilized for the purposes for which it is intended. The terms “substantially complete” and “substantially completed” as applied to all or part of the Work refer to Substantial Completion thereof.
45. *Successful Bidder*—The Bidder submitting a responsive Bid to whom Owner makes an award.
46. *Supplementary Conditions*—That part of the Contract Documents which amends or supplements these General Conditions.
47. *Supplier*—A manufacturer, fabricator, supplier, distributor, materialman, or vendor having a direct contract with Contractor or with any Subcontractor to furnish materials or equipment to be incorporated in the Work by Contractor or Subcontractor.
48. *Underground Facilities*—All underground pipelines, conduits, ducts, cables, wires, manholes, vaults, tanks, tunnels, or other such facilities or attachments, and any encasements containing such facilities, including those that convey electricity, gases, steam, liquid petroleum products, telephone or other communications, cable television, water, wastewater, storm water, other liquids or chemicals, or traffic or other control systems.
49. *Unit Price Work*—Work to be paid for on the basis of unit prices.
50. *Work*—The entire construction or the various separately identifiable parts thereof required to be provided under the Contract Documents. Work includes and is the result of performing or providing all labor, services, and documentation necessary to produce such construction, and furnishing, installing, and incorporating all materials and equipment into such construction, all as required by the Contract Documents.
51. *Work Change Directive*—A written statement to Contractor issued on or after the Effective Date of the Agreement and signed by Owner and recommended by Engineer ordering an



addition, deletion, or revision in the Work, or responding to differing or unforeseen subsurface or physical conditions under which the Work is to be performed or to emergencies. A Work Change Directive will not change the Contract Price or the Contract Times but is evidence that the parties expect that the change ordered or documented by a Work Change Directive will be incorporated in a subsequently issued Change Order following negotiations by the parties as to its effect, if any, on the Contract Price or Contract Times.

## 1.02 Terminology

A. The words and terms discussed in Paragraph 1.02.B through F are not defined but, when used in the Bidding Requirements or Contract Documents, have the indicated meaning.

### B. *Intent of Certain Terms or Adjectives:*

1. The Contract Documents include the terms “as allowed,” “as approved,” “as ordered,” “as directed” or terms of like effect or import to authorize an exercise of professional judgment by Engineer. In addition, the adjectives “reasonable,” “suitable,” “acceptable,” “proper,” “satisfactory,” or adjectives of like effect or import are used to describe an action or determination of Engineer as to the Work. It is intended that such exercise of professional judgment, action, or determination will be solely to evaluate, in general, the Work for compliance with the information in the Contract Documents and with the design concept of the Project as a functioning whole as shown or indicated in the Contract Documents (unless there is a specific statement indicating otherwise). The use of any such term or adjective is not intended to and shall not be effective to assign to Engineer any duty or authority to supervise or direct the performance of the Work, or any duty or authority to undertake responsibility contrary to the provisions of Paragraph 9.09 or any other provision of the Contract Documents.

### C. *Day:*

1. The word “day” means a calendar day of 24 hours measured from midnight to the next midnight.

### D. *Defective:*

1. The word “defective,” when modifying the word “Work,” refers to Work that is unsatisfactory, faulty, or deficient in that it:
  - a. does not conform to the Contract Documents; or
  - b. does not meet the requirements of any applicable inspection, reference standard, test, or approval referred to in the Contract Documents; or
  - c. has been damaged prior to Engineer’s recommendation of final payment (unless responsibility for the protection thereof has been assumed by Owner at Substantial Completion in accordance with Paragraph 14.04 or 14.05).

E. *Furnish, Install, Perform, Provide:*

1. The word “furnish,” when used in connection with services, materials, or equipment, shall mean to supply and deliver said services, materials, or equipment to the Site (or some other specified location) ready for use or installation and in usable or operable condition.
2. The word “install,” when used in connection with services, materials, or equipment, shall mean to put into use or place in final position said services, materials, or equipment complete and ready for intended use.
3. The words “perform” or “provide,” when used in connection with services, materials, or equipment, shall mean to furnish and install said services, materials, or equipment complete and ready for intended use.
4. When “furnish,” “install,” “perform,” or “provide” is not used in connection with services, materials, or equipment in a context clearly requiring an obligation of Contractor, “provide” is implied.

F. Unless stated otherwise in the Contract Documents, words or phrases that have a well-known technical or construction industry or trade meaning are used in the Contract Documents in accordance with such recognized meaning.

## **ARTICLE 2 – PRELIMINARY MATTERS**

### **2.01 *Delivery of Bonds and Evidence of Insurance***

- A. When Contractor delivers the executed counterparts of the Agreement to Owner, Contractor shall also deliver to Owner such bonds as Contractor may be required to furnish.
- B. *Evidence of Insurance:* Before any Work at the Site is started, Contractor and Owner shall each deliver to the other, with copies to each additional insured identified in the Supplementary Conditions, certificates of insurance (and other evidence of insurance which either of them or any additional insured may reasonably request) which Contractor and Owner respectively are required to purchase and maintain in accordance with Article 5.

### **2.02 *Copies of Documents***

- A. Owner shall furnish to Contractor up to ten printed or hard copies of the Drawings and Project Manual. Additional copies will be furnished upon request at the cost of reproduction.

### **2.03 *Commencement of Contract Times; Notice to Proceed***

- A. The Contract Times will commence to run on the thirtieth day after the Effective Date of the Agreement or, if a Notice to Proceed is given, on the day indicated in the Notice to Proceed. A Notice to Proceed may be given at any time within 30 days after the Effective Date of the Agreement. In no event will the Contract Times commence to run later than the sixtieth day after the day of Bid opening or the thirtieth day after the Effective Date of the Agreement, whichever date is earlier.

## 2.04 *Starting the Work*

- A. Contractor shall start to perform the Work on the date when the Contract Times commence to run. No Work shall be done at the Site prior to the date on which the Contract Times commence to run.

## 2.05 *Before Starting Construction*

- A. *Preliminary Schedules:* Within 10 days after the Effective Date of the Agreement (unless otherwise specified in the General Requirements), Contractor shall submit to Engineer for timely review:
  - 1. a preliminary Progress Schedule indicating the times (numbers of days or dates) for starting and completing the various stages of the Work, including any Milestones specified in the Contract Documents;
  - 2. a preliminary Schedule of Submittals; and
  - 3. a preliminary Schedule of Values for all of the Work which includes quantities and prices of items which when added together equal the Contract Price and subdivides the Work into component parts in sufficient detail to serve as the basis for progress payments during performance of the Work. Such prices will include an appropriate amount of overhead and profit applicable to each item of Work.

## 2.06 *Preconstruction Conference; Designation of Authorized Representatives*

- A. Before any Work at the Site is started, a conference attended by Owner, Contractor, Engineer, and others as appropriate will be held to establish a working understanding among the parties as to the Work and to discuss the schedules referred to in Paragraph 2.05.A, procedures for handling Shop Drawings and other submittals, processing Applications for Payment, and maintaining required records.
- B. At this conference Owner and Contractor each shall designate, in writing, a specific individual to act as its authorized representative with respect to the services and responsibilities under the Contract. Such individuals shall have the authority to transmit instructions, receive information, render decisions relative to the Contract, and otherwise act on behalf of each respective party.

## 2.07 *Initial Acceptance of Schedules*

- A. At least 10 days before submission of the first Application for Payment a conference attended by Contractor, Engineer, and others as appropriate will be held to review for acceptability to Engineer as provided below the schedules submitted in accordance with Paragraph 2.05.A. Contractor shall have an additional 10 days to make corrections and adjustments and to complete and resubmit the schedules. No progress payment shall be made to Contractor until acceptable schedules are submitted to Engineer.
  - 1. The Progress Schedule will be acceptable to Engineer if it provides an orderly progression of the Work to completion within the Contract Times. Such acceptance will not impose on

Engineer responsibility for the Progress Schedule, for sequencing, scheduling, or progress of the Work, nor interfere with or relieve Contractor from Contractor's full responsibility therefor.

2. Contractor's Schedule of Submittals will be acceptable to Engineer if it provides a workable arrangement for reviewing and processing the required submittals.
3. Contractor's Schedule of Values will be acceptable to Engineer as to form and substance if it provides a reasonable allocation of the Contract Price to component parts of the Work.

### **ARTICLE 3 – CONTRACT DOCUMENTS: INTENT, AMENDING, REUSE**

#### **3.01 *Intent***

- A. The Contract Documents are complementary; what is required by one is as binding as if required by all.
- B. It is the intent of the Contract Documents to describe a functionally complete project (or part thereof) to be constructed in accordance with the Contract Documents. Any labor, documentation, services, materials, or equipment that reasonably may be inferred from the Contract Documents or from prevailing custom or trade usage as being required to produce the indicated result will be provided whether or not specifically called for, at no additional cost to Owner.
- C. Clarifications and interpretations of the Contract Documents shall be issued by Engineer as provided in Article 9.

#### **3.02 *Reference Standards***

- A. Standards, Specifications, Codes, Laws, and Regulations
  1. Reference to standards, specifications, manuals, or codes of any technical society, organization, or association, or to Laws or Regulations, whether such reference be specific or by implication, shall mean the standard, specification, manual, code, or Laws or Regulations in effect at the time of opening of Bids (or on the Effective Date of the Agreement if there were no Bids), except as may be otherwise specifically stated in the Contract Documents.
  2. No provision of any such standard, specification, manual, or code, or any instruction of a Supplier, shall be effective to change the duties or responsibilities of Owner, Contractor, or Engineer, or any of their subcontractors, consultants, agents, or employees, from those set forth in the Contract Documents. No such provision or instruction shall be effective to assign to Owner, Engineer, or any of their officers, directors, members, partners, employees, agents, consultants, or subcontractors, any duty or authority to supervise or direct the performance of the Work or any duty or authority to undertake responsibility inconsistent with the provisions of the Contract Documents.

### 3.03 *Reporting and Resolving Discrepancies*

#### A. *Reporting Discrepancies:*

1. *Contractor's Review of Contract Documents Before Starting Work:* Before undertaking each part of the Work, Contractor shall carefully study and compare the Contract Documents and check and verify pertinent figures therein and all applicable field measurements. Contractor shall promptly report in writing to Engineer any conflict, error, ambiguity, or discrepancy which Contractor discovers, or has actual knowledge of, and shall obtain a written interpretation or clarification from Engineer before proceeding with any Work affected thereby.
2. *Contractor's Review of Contract Documents During Performance of Work:* If, during the performance of the Work, Contractor discovers any conflict, error, ambiguity, or discrepancy within the Contract Documents, or between the Contract Documents and (a) any applicable Law or Regulation, (b) any standard, specification, manual, or code, or (c) any instruction of any Supplier, then Contractor shall promptly report it to Engineer in writing. Contractor shall not proceed with the Work affected thereby (except in an emergency as required by Paragraph 6.16.A) until an amendment or supplement to the Contract Documents has been issued by one of the methods indicated in Paragraph 3.04.
3. Contractor shall not be liable to Owner or Engineer for failure to report any conflict, error, ambiguity, or discrepancy in the Contract Documents unless Contractor had actual knowledge thereof.

#### B. *Resolving Discrepancies:*

1. Except as may be otherwise specifically stated in the Contract Documents, the provisions of the Contract Documents shall take precedence in resolving any conflict, error, ambiguity, or discrepancy between the provisions of the Contract Documents and:
  - a. the provisions of any standard, specification, manual, or code, or the instruction of any Supplier (whether or not specifically incorporated by reference in the Contract Documents); or
  - b. the provisions of any Laws or Regulations applicable to the performance of the Work (unless such an interpretation of the provisions of the Contract Documents would result in violation of such Law or Regulation).

### 3.04 *Amending and Supplementing Contract Documents*

- A. The Contract Documents may be amended to provide for additions, deletions, and revisions in the Work or to modify the terms and conditions thereof by either a Change Order or a Work Change Directive.
- B. The requirements of the Contract Documents may be supplemented, and minor variations and deviations in the Work may be authorized, by one or more of the following ways:

1. A Field Order;
2. Engineer's approval of a Shop Drawing or Sample (subject to the provisions of Paragraph 6.17.D.3); or
3. Engineer's written interpretation or clarification.

### 3.05 *Reuse of Documents*

- A. Contractor and any Subcontractor or Supplier shall not:
1. have or acquire any title to or ownership rights in any of the Drawings, Specifications, or other documents (or copies of any thereof) prepared by or bearing the seal of Engineer or its consultants, including electronic media editions; or
  2. reuse any such Drawings, Specifications, other documents, or copies thereof on extensions of the Project or any other project without written consent of Owner and Engineer and specific written verification or adaptation by Engineer.
- B. The prohibitions of this Paragraph 3.05 will survive final payment, or termination of the Contract. Nothing herein shall preclude Contractor from retaining copies of the Contract Documents for record purposes.

### 3.06 *Electronic Data*

- A. Unless otherwise stated in the Supplementary Conditions, the data furnished by Owner or Engineer to Contractor, or by Contractor to Owner or Engineer, that may be relied upon are limited to the printed copies (also known as hard copies). Files in electronic media format of text, data, graphics, or other types are furnished only for the convenience of the receiving party. Any conclusion or information obtained or derived from such electronic files will be at the user's sole risk. If there is a discrepancy between the electronic files and the hard copies, the hard copies govern.
- B. Because data stored in electronic media format can deteriorate or be modified inadvertently or otherwise without authorization of the data's creator, the party receiving electronic files agrees that it will perform acceptance tests or procedures within 60 days, after which the receiving party shall be deemed to have accepted the data thus transferred. Any errors detected within the 60-day acceptance period will be corrected by the transferring party.
- C. When transferring documents in electronic media format, the transferring party makes no representations as to long term compatibility, usability, or readability of documents resulting from the use of software application packages, operating systems, or computer hardware differing from those used by the data's creator.

**ARTICLE 4 – AVAILABILITY OF LANDS; SUBSURFACE AND PHYSICAL CONDITIONS;  
HAZARDOUS ENVIRONMENTAL CONDITIONS; REFERENCE POINTS**

4.01 *Availability of Lands*

- A. Owner shall furnish the Site. Owner shall notify Contractor of any encumbrances or restrictions not of general application but specifically related to use of the Site with which Contractor must comply in performing the Work. Owner will obtain in a timely manner and pay for easements for permanent structures or permanent changes in existing facilities. If Contractor and Owner are unable to agree on entitlement to or on the amount or extent, if any, of any adjustment in the Contract Price or Contract Times, or both, as a result of any delay in Owner's furnishing the Site or a part thereof, Contractor may make a Claim therefor as provided in Paragraph 10.05.
- B. Upon reasonable written request, Owner shall furnish Contractor with a current statement of record legal title and legal description of the lands upon which the Work is to be performed and Owner's interest therein as necessary for giving notice of or filing a mechanic's or construction lien against such lands in accordance with applicable Laws and Regulations.
- C. Contractor shall provide for all additional lands and access thereto that may be required for temporary construction facilities or storage of materials and equipment.

4.02 *Subsurface and Physical Conditions*

- A. *Reports and Drawings:* The Supplementary Conditions identify:
  - 1. those reports known to Owner of explorations and tests of subsurface conditions at or contiguous to the Site; and
  - 2. those drawings known to Owner of physical conditions relating to existing surface or subsurface structures at the Site (except Underground Facilities).
- B. *Limited Reliance by Contractor on Technical Data Authorized:* Contractor may rely upon the accuracy of the "technical data" contained in such reports and drawings, but such reports and drawings are not Contract Documents. Such "technical data" is identified in the Supplementary Conditions. Except for such reliance on such "technical data," Contractor may not rely upon or make any claim against Owner or Engineer, or any of their officers, directors, members, partners, employees, agents, consultants, or subcontractors with respect to:
  - 1. the completeness of such reports and drawings for Contractor's purposes, including, but not limited to, any aspects of the means, methods, techniques, sequences, and procedures of construction to be employed by Contractor, and safety precautions and programs incident thereto; or
  - 2. other data, interpretations, opinions, and information contained in such reports or shown or indicated in such drawings; or
  - 3. any Contractor interpretation of or conclusion drawn from any "technical data" or any such other data, interpretations, opinions, or information.

#### 4.03 *Differing Subsurface or Physical Conditions*

A. *Notice:* If Contractor believes that any subsurface or physical condition that is uncovered or revealed either:

1. is of such a nature as to establish that any “technical data” on which Contractor is entitled to rely as provided in Paragraph 4.02 is materially inaccurate; or
2. is of such a nature as to require a change in the Contract Documents; or
3. differs materially from that shown or indicated in the Contract Documents; or
4. is of an unusual nature, and differs materially from conditions ordinarily encountered and generally recognized as inherent in work of the character provided for in the Contract Documents;

then Contractor shall, promptly after becoming aware thereof and before further disturbing the subsurface or physical conditions or performing any Work in connection therewith (except in an emergency as required by Paragraph 6.16.A), notify Owner and Engineer in writing about such condition. Contractor shall not further disturb such condition or perform any Work in connection therewith (except as aforesaid) until receipt of written order to do so.

B. *Engineer’s Review:* After receipt of written notice as required by Paragraph 4.03.A, Engineer will promptly review the pertinent condition, determine the necessity of Owner’s obtaining additional exploration or tests with respect thereto, and advise Owner in writing (with a copy to Contractor) of Engineer’s findings and conclusions.

C. *Possible Price and Times Adjustments:*

1. The Contract Price or the Contract Times, or both, will be equitably adjusted to the extent that the existence of such differing subsurface or physical condition causes an increase or decrease in Contractor’s cost of, or time required for, performance of the Work; subject, however, to the following:
  - a. such condition must meet any one or more of the categories described in Paragraph 4.03.A; and
  - b. with respect to Work that is paid for on a unit price basis, any adjustment in Contract Price will be subject to the provisions of Paragraphs 9.07 and 11.03.
2. Contractor shall not be entitled to any adjustment in the Contract Price or Contract Times if:
  - a. Contractor knew of the existence of such conditions at the time Contractor made a final commitment to Owner with respect to Contract Price and Contract Times by the submission of a Bid or becoming bound under a negotiated contract; or
  - b. the existence of such condition could reasonably have been discovered or revealed as a result of any examination, investigation, exploration, test, or study of the Site and



contiguous areas required by the Bidding Requirements or Contract Documents to be conducted by or for Contractor prior to Contractor's making such final commitment; or

- c. Contractor failed to give the written notice as required by Paragraph 4.03.A.
3. If Owner and Contractor are unable to agree on entitlement to or on the amount or extent, if any, of any adjustment in the Contract Price or Contract Times, or both, a Claim may be made therefor as provided in Paragraph 10.05. However, neither Owner or Engineer, or any of their officers, directors, members, partners, employees, agents, consultants, or subcontractors shall be liable to Contractor for any claims, costs, losses, or damages (including but not limited to all fees and charges of engineers, architects, attorneys, and other professionals and all court or arbitration or other dispute resolution costs) sustained by Contractor on or in connection with any other project or anticipated project.

#### 4.04 *Underground Facilities*

A. *Shown or Indicated:* The information and data shown or indicated in the Contract Documents with respect to existing Underground Facilities at or contiguous to the Site is based on information and data furnished to Owner or Engineer by the owners of such Underground Facilities, including Owner, or by others. Unless it is otherwise expressly provided in the Supplementary Conditions:

1. Owner and Engineer shall not be responsible for the accuracy or completeness of any such information or data provided by others; and
2. the cost of all of the following will be included in the Contract Price, and Contractor shall have full responsibility for:
  - a. reviewing and checking all such information and data;
  - b. locating all Underground Facilities shown or indicated in the Contract Documents;
  - c. coordination of the Work with the owners of such Underground Facilities, including Owner, during construction; and
  - d. the safety and protection of all such Underground Facilities and repairing any damage thereto resulting from the Work.

B. *Not Shown or Indicated:*

1. If an Underground Facility is uncovered or revealed at or contiguous to the Site which was not shown or indicated, or not shown or indicated with reasonable accuracy in the Contract Documents, Contractor shall, promptly after becoming aware thereof and before further disturbing conditions affected thereby or performing any Work in connection therewith (except in an emergency as required by Paragraph 6.16.A), identify the owner of such Underground Facility and give written notice to that owner and to Owner and Engineer. Engineer will promptly review the Underground Facility and determine the extent, if any, to which a change is required in the Contract Documents to reflect and document the

consequences of the existence or location of the Underground Facility. During such time, Contractor shall be responsible for the safety and protection of such Underground Facility.

2. If Engineer concludes that a change in the Contract Documents is required, a Work Change Directive or a Change Order will be issued to reflect and document such consequences. An equitable adjustment shall be made in the Contract Price or Contract Times, or both, to the extent that they are attributable to the existence or location of any Underground Facility that was not shown or indicated or not shown or indicated with reasonable accuracy in the Contract Documents and that Contractor did not know of and could not reasonably have been expected to be aware of or to have anticipated. If Owner and Contractor are unable to agree on entitlement to or on the amount or extent, if any, of any such adjustment in Contract Price or Contract Times, Owner or Contractor may make a Claim therefore as provided in Paragraph 10.05.

#### 4.05 *Reference Points*

- A. Owner shall provide engineering surveys to establish reference points for construction which in Engineer's judgment are necessary to enable Contractor to proceed with the Work. Contractor shall be responsible for laying out the Work, shall protect and preserve the established reference points and property monuments, and shall make no changes or relocations without the prior written approval of Owner. Contractor shall report to Engineer whenever any reference point or property monument is lost or destroyed or requires relocation because of necessary changes in grades or locations, and shall be responsible for the accurate replacement or relocation of such reference points or property monuments by professionally qualified personnel.

#### 4.06 *Hazardous Environmental Condition at Site*

- A. *Reports and Drawings:* The Supplementary Conditions identify those reports and drawings known to Owner relating to Hazardous Environmental Conditions that have been identified at the Site.
- B. *Limited Reliance by Contractor on Technical Data Authorized:* Contractor may rely upon the accuracy of the "technical data" contained in such reports and drawings, but such reports and drawings are not Contract Documents. Such "technical data" is identified in the Supplementary Conditions. Except for such reliance on such "technical data," Contractor may not rely upon or make any claim against Owner or Engineer, or any of their officers, directors, members, partners, employees, agents, consultants, or subcontractors with respect to:
  1. the completeness of such reports and drawings for Contractor's purposes, including, but not limited to, any aspects of the means, methods, techniques, sequences and procedures of construction to be employed by Contractor and safety precautions and programs incident thereto; or
  2. other data, interpretations, opinions and information contained in such reports or shown or indicated in such drawings; or
  3. any Contractor interpretation of or conclusion drawn from any "technical data" or any such other data, interpretations, opinions or information.

- C. Contractor shall not be responsible for any Hazardous Environmental Condition uncovered or revealed at the Site which was not shown or indicated in Drawings or Specifications or identified in the Contract Documents to be within the scope of the Work. Contractor shall be responsible for a Hazardous Environmental Condition created with any materials brought to the Site by Contractor, Subcontractors, Suppliers, or anyone else for whom Contractor is responsible.
- D. If Contractor encounters a Hazardous Environmental Condition or if Contractor or anyone for whom Contractor is responsible creates a Hazardous Environmental Condition, Contractor shall immediately: (i) secure or otherwise isolate such condition; (ii) stop all Work in connection with such condition and in any area affected thereby (except in an emergency as required by Paragraph 6.16.A); and (iii) notify Owner and Engineer (and promptly thereafter confirm such notice in writing). Owner shall promptly consult with Engineer concerning the necessity for Owner to retain a qualified expert to evaluate such condition or take corrective action, if any. Promptly after consulting with Engineer, Owner shall take such actions as are necessary to permit Owner to timely obtain required permits and provide Contractor the written notice required by Paragraph 4.06.E.
- E. Contractor shall not be required to resume Work in connection with such condition or in any affected area until after Owner has obtained any required permits related thereto and delivered written notice to Contractor: (i) specifying that such condition and any affected area is or has been rendered safe for the resumption of Work; or (ii) specifying any special conditions under which such Work may be resumed safely. If Owner and Contractor cannot agree as to entitlement to or on the amount or extent, if any, of any adjustment in Contract Price or Contract Times, or both, as a result of such Work stoppage or such special conditions under which Work is agreed to be resumed by Contractor, either party may make a Claim therefor as provided in Paragraph 10.05.
- F. If after receipt of such written notice Contractor does not agree to resume such Work based on a reasonable belief it is unsafe, or does not agree to resume such Work under such special conditions, then Owner may order the portion of the Work that is in the area affected by such condition to be deleted from the Work. If Owner and Contractor cannot agree as to entitlement to or on the amount or extent, if any, of an adjustment in Contract Price or Contract Times as a result of deleting such portion of the Work, then either party may make a Claim therefor as provided in Paragraph 10.05. Owner may have such deleted portion of the Work performed by Owner's own forces or others in accordance with Article 7.
- G. To the fullest extent permitted by Laws and Regulations, Owner shall indemnify and hold harmless Contractor, Subcontractors, and Engineer, and the officers, directors, members, partners, employees, agents, consultants, and subcontractors of each and any of them from and against all claims, costs, losses, and damages (including but not limited to all fees and charges of engineers, architects, attorneys, and other professionals and all court or arbitration or other dispute resolution costs) arising out of or relating to a Hazardous Environmental Condition, provided that such Hazardous Environmental Condition: (i) was not shown or indicated in the Drawings or Specifications or identified in the Contract Documents to be included within the scope of the Work, and (ii) was not created by Contractor or by anyone for whom Contractor is responsible. Nothing in this Paragraph 4.06.G shall obligate Owner to indemnify any individual or entity from and against the consequences of that individual's or entity's own negligence.

- H. To the fullest extent permitted by Laws and Regulations, Contractor shall indemnify and hold harmless Owner and Engineer, and the officers, directors, members, partners, employees, agents, consultants, and subcontractors of each and any of them from and against all claims, costs, losses, and damages (including but not limited to all fees and charges of engineers, architects, attorneys, and other professionals and all court or arbitration or other dispute resolution costs) arising out of or relating to a Hazardous Environmental Condition created by Contractor or by anyone for whom Contractor is responsible. Nothing in this Paragraph 4.06.H shall obligate Contractor to indemnify any individual or entity from and against the consequences of that individual's or entity's own negligence.
- I. The provisions of Paragraphs 4.02, 4.03, and 4.04 do not apply to a Hazardous Environmental Condition uncovered or revealed at the Site.

## **ARTICLE 5 – BONDS AND INSURANCE**

### *5.01 Performance, Payment, and Other Bonds*

- A. Contractor shall furnish performance and payment bonds, each in an amount at least equal to the Contract Price as security for the faithful performance and payment of all of Contractor's obligations under the Contract Documents. These bonds shall remain in effect until one year after the date when final payment becomes due or until completion of the correction period specified in Paragraph 13.07, whichever is later, except as provided otherwise by Laws or Regulations or by the Contract Documents. Contractor shall also furnish such other bonds as are required by the Contract Documents.
- B. All bonds shall be in the form prescribed by the Contract Documents except as provided otherwise by Laws or Regulations, and shall be executed by such sureties as are named in the list of "Companies Holding Certificates of Authority as Acceptable Sureties on Federal Bonds and as Acceptable Reinsuring Companies" as published in Circular 570 (amended) by the Financial Management Service, Surety Bond Branch, U.S. Department of the Treasury. All bonds signed by an agent or attorney-in-fact must be accompanied by a certified copy of that individual's authority to bind the surety. The evidence of authority shall show that it is effective on the date the agent or attorney-in-fact signed each bond.
- C. If the surety on any bond furnished by Contractor is declared bankrupt or becomes insolvent or its right to do business is terminated in any state where any part of the Project is located or it ceases to meet the requirements of Paragraph 5.01.B, Contractor shall promptly notify Owner and Engineer and shall, within 20 days after the event giving rise to such notification, provide another bond and surety, both of which shall comply with the requirements of Paragraphs 5.01.B and 5.02.

### *5.02 Licensed Sureties and Insurers*

- A. All bonds and insurance required by the Contract Documents to be purchased and maintained by Owner or Contractor shall be obtained from surety or insurance companies that are duly licensed or authorized in the jurisdiction in which the Project is located to issue bonds or insurance policies for the limits and coverages so required. Such surety and insurance companies shall also

meet such additional requirements and qualifications as may be provided in the Supplementary Conditions.

#### 5.03 *Certificates of Insurance*

- A. Contractor shall deliver to Owner, with copies to each additional insured and loss payee identified in the Supplementary Conditions, certificates of insurance (and other evidence of insurance requested by Owner or any other additional insured) which Contractor is required to purchase and maintain.
- B. Owner shall deliver to Contractor, with copies to each additional insured and loss payee identified in the Supplementary Conditions, certificates of insurance (and other evidence of insurance requested by Contractor or any other additional insured) which Owner is required to purchase and maintain.
- C. Failure of Owner to demand such certificates or other evidence of Contractor's full compliance with these insurance requirements or failure of Owner to identify a deficiency in compliance from the evidence provided shall not be construed as a waiver of Contractor's obligation to maintain such insurance.
- D. Owner does not represent that insurance coverage and limits established in this Contract necessarily will be adequate to protect Contractor.
- E. The insurance and insurance limits required herein shall not be deemed as a limitation on Contractor's liability under the indemnities granted to Owner in the Contract Documents.

#### 5.04 *Contractor's Insurance*

- A. Contractor shall purchase and maintain such insurance as is appropriate for the Work being performed and as will provide protection from claims set forth below which may arise out of or result from Contractor's performance of the Work and Contractor's other obligations under the Contract Documents, whether it is to be performed by Contractor, any Subcontractor or Supplier, or by anyone directly or indirectly employed by any of them to perform any of the Work, or by anyone for whose acts any of them may be liable:
  - 1. claims under workers' compensation, disability benefits, and other similar employee benefit acts;
  - 2. claims for damages because of bodily injury, occupational sickness or disease, or death of Contractor's employees;
  - 3. claims for damages because of bodily injury, sickness or disease, or death of any person other than Contractor's employees;
  - 4. claims for damages insured by reasonably available personal injury liability coverage which are sustained:

- a. by any person as a result of an offense directly or indirectly related to the employment of such person by Contractor, or
  - b. by any other person for any other reason;
5. claims for damages, other than to the Work itself, because of injury to or destruction of tangible property wherever located, including loss of use resulting therefrom; and
  6. claims for damages because of bodily injury or death of any person or property damage arising out of the ownership, maintenance or use of any motor vehicle.

B. The policies of insurance required by this Paragraph 5.04 shall:

1. with respect to insurance required by Paragraphs 5.04.A.3 through 5.04.A.6 inclusive, be written on an occurrence basis, include as additional insureds (subject to any customary exclusion regarding professional liability) Owner and Engineer, and any other individuals or entities identified in the Supplementary Conditions, all of whom shall be listed as additional insureds, and include coverage for the respective officers, directors, members, partners, employees, agents, consultants, and subcontractors of each and any of all such additional insureds, and the insurance afforded to these additional insureds shall provide primary coverage for all claims covered thereby;
2. include at least the specific coverages and be written for not less than the limits of liability provided in the Supplementary Conditions or required by Laws or Regulations, whichever is greater;
3. include contractual liability insurance covering Contractor's indemnity obligations under Paragraphs 6.11 and 6.20;
4. contain a provision or endorsement that the coverage afforded will not be canceled, materially changed or renewal refused until at least 30 days prior written notice has been given to Owner and Contractor and to each other additional insured identified in the Supplementary Conditions to whom a certificate of insurance has been issued (and the certificates of insurance furnished by the Contractor pursuant to Paragraph 5.03 will so provide);
5. remain in effect at least until final payment and at all times thereafter when Contractor may be correcting, removing, or replacing defective Work in accordance with Paragraph 13.07; and
6. include completed operations coverage:
  - a. Such insurance shall remain in effect for two years after final payment.
  - b. Contractor shall furnish Owner and each other additional insured identified in the Supplementary Conditions, to whom a certificate of insurance has been issued, evidence satisfactory to Owner and any such additional insured of continuation of such insurance at final payment and one year thereafter.

5.05 *Owner's Liability Insurance*

- A. In addition to the insurance required to be provided by Contractor under Paragraph 5.04, Owner, at Owner's option, may purchase and maintain at Owner's expense Owner's own liability insurance as will protect Owner against claims which may arise from operations under the Contract Documents.

5.06 *Property Insurance*

- A. Unless otherwise provided in the Supplementary Conditions, Owner shall purchase and maintain property insurance upon the Work at the Site in the amount of the full replacement cost thereof (subject to such deductible amounts as may be provided in the Supplementary Conditions or required by Laws and Regulations). This insurance shall:
1. include the interests of Owner, Contractor, Subcontractors, and Engineer, and any other individuals or entities identified in the Supplementary Conditions, and the officers, directors, members, partners, employees, agents, consultants, and subcontractors of each and any of them, each of whom is deemed to have an insurable interest and shall be listed as a loss payee;
  2. be written on a Builder's Risk "all-risk" policy form that shall at least include insurance for physical loss or damage to the Work, temporary buildings, falsework, and materials and equipment in transit, and shall insure against at least the following perils or causes of loss: fire, lightning, extended coverage, theft, vandalism and malicious mischief, earthquake, collapse, debris removal, demolition occasioned by enforcement of Laws and Regulations, water damage (other than that caused by flood), and such other perils or causes of loss as may be specifically required by the Supplementary Conditions.
  3. include expenses incurred in the repair or replacement of any insured property (including but not limited to fees and charges of engineers and architects);
  4. cover materials and equipment stored at the Site or at another location that was agreed to in writing by Owner prior to being incorporated in the Work, provided that such materials and equipment have been included in an Application for Payment recommended by Engineer;
  5. allow for partial utilization of the Work by Owner;
  6. include testing and startup; and
  7. be maintained in effect until final payment is made unless otherwise agreed to in writing by Owner, Contractor, and Engineer with 30 days written notice to each other loss payee to whom a certificate of insurance has been issued.
- B. Owner shall purchase and maintain such equipment breakdown insurance or additional property insurance as may be required by the Supplementary Conditions or Laws and Regulations which will include the interests of Owner, Contractor, Subcontractors, and Engineer, and any other individuals or entities identified in the Supplementary Conditions, and the officers, directors,

members, partners, employees, agents, consultants and subcontractors of each and any of them, each of whom is deemed to have an insurable interest and shall be listed as a loss payee.

- C. All the policies of insurance (and the certificates or other evidence thereof) required to be purchased and maintained in accordance with this Paragraph 5.06 will contain a provision or endorsement that the coverage afforded will not be canceled or materially changed or renewal refused until at least 30 days prior written notice has been given to Owner and Contractor and to each other loss payee to whom a certificate of insurance has been issued and will contain waiver provisions in accordance with Paragraph 5.07.
- D. Owner shall not be responsible for purchasing and maintaining any property insurance specified in this Paragraph 5.06 to protect the interests of Contractor, Subcontractors, or others in the Work to the extent of any deductible amounts that are identified in the Supplementary Conditions. The risk of loss within such identified deductible amount will be borne by Contractor, Subcontractors, or others suffering any such loss, and if any of them wishes property insurance coverage within the limits of such amounts, each may purchase and maintain it at the purchaser's own expense.
- E. If Contractor requests in writing that other special insurance be included in the property insurance policies provided under this Paragraph 5.06, Owner shall, if possible, include such insurance, and the cost thereof will be charged to Contractor by appropriate Change Order. Prior to commencement of the Work at the Site, Owner shall in writing advise Contractor whether or not such other insurance has been procured by Owner.

#### 5.07 *Waiver of Rights*

- A. Owner and Contractor intend that all policies purchased in accordance with Paragraph 5.06 will protect Owner, Contractor, Subcontractors, and Engineer, and all other individuals or entities identified in the Supplementary Conditions as loss payees (and the officers, directors, members, partners, employees, agents, consultants, and subcontractors of each and any of them) in such policies and will provide primary coverage for all losses and damages caused by the perils or causes of loss covered thereby. All such policies shall contain provisions to the effect that in the event of payment of any loss or damage the insurers will have no rights of recovery against any of the insureds or loss payees thereunder. Owner and Contractor waive all rights against each other and their respective officers, directors, members, partners, employees, agents, consultants and subcontractors of each and any of them for all losses and damages caused by, arising out of or resulting from any of the perils or causes of loss covered by such policies and any other property insurance applicable to the Work; and, in addition, waive all such rights against Subcontractors and Engineer, and all other individuals or entities identified in the Supplementary Conditions as loss payees (and the officers, directors, members, partners, employees, agents, consultants, and subcontractors of each and any of them) under such policies for losses and damages so caused. None of the above waivers shall extend to the rights that any party making such waiver may have to the proceeds of insurance held by Owner as trustee or otherwise payable under any policy so issued.
- B. Owner waives all rights against Contractor, Subcontractors, and Engineer, and the officers, directors, members, partners, employees, agents, consultants and subcontractors of each and any of them for:



1. loss due to business interruption, loss of use, or other consequential loss extending beyond direct physical loss or damage to Owner's property or the Work caused by, arising out of, or resulting from fire or other perils whether or not insured by Owner; and
  2. loss or damage to the completed Project or part thereof caused by, arising out of, or resulting from fire or other insured peril or cause of loss covered by any property insurance maintained on the completed Project or part thereof by Owner during partial utilization pursuant to Paragraph 14.05, after Substantial Completion pursuant to Paragraph 14.04, or after final payment pursuant to Paragraph 14.07.
- C. Any insurance policy maintained by Owner covering any loss, damage or consequential loss referred to in Paragraph 5.07.B shall contain provisions to the effect that in the event of payment of any such loss, damage, or consequential loss, the insurers will have no rights of recovery against Contractor, Subcontractors, or Engineer, and the officers, directors, members, partners, employees, agents, consultants and subcontractors of each and any of them.

#### 5.08 *Receipt and Application of Insurance Proceeds*

- A. Any insured loss under the policies of insurance required by Paragraph 5.06 will be adjusted with Owner and made payable to Owner as fiduciary for the loss payees, as their interests may appear, subject to the requirements of any applicable mortgage clause and of Paragraph 5.08.B. Owner shall deposit in a separate account any money so received and shall distribute it in accordance with such agreement as the parties in interest may reach. If no other special agreement is reached, the damaged Work shall be repaired or replaced, the moneys so received applied on account thereof, and the Work and the cost thereof covered by an appropriate Change Order.
- B. Owner as fiduciary shall have power to adjust and settle any loss with the insurers unless one of the parties in interest shall object in writing within 15 days after the occurrence of loss to Owner's exercise of this power. If such objection be made, Owner as fiduciary shall make settlement with the insurers in accordance with such agreement as the parties in interest may reach. If no such agreement among the parties in interest is reached, Owner as fiduciary shall adjust and settle the loss with the insurers and, if required in writing by any party in interest, Owner as fiduciary shall give bond for the proper performance of such duties.

#### 5.09 *Acceptance of Bonds and Insurance; Option to Replace*

- A. If either Owner or Contractor has any objection to the coverage afforded by or other provisions of the bonds or insurance required to be purchased and maintained by the other party in accordance with Article 5 on the basis of non-conformance with the Contract Documents, the objecting party shall so notify the other party in writing within 10 days after receipt of the certificates (or other evidence requested) required by Paragraph 2.01.B. Owner and Contractor shall each provide to the other such additional information in respect of insurance provided as the other may reasonably request. If either party does not purchase or maintain all of the bonds and insurance required of such party by the Contract Documents, such party shall notify the other party in writing of such failure to purchase prior to the start of the Work, or of such failure to maintain prior to any change in the required coverage. Without prejudice to any other right or remedy, the other party may elect to obtain equivalent bonds or insurance to protect such other party's

interests at the expense of the party who was required to provide such coverage, and a Change Order shall be issued to adjust the Contract Price accordingly.

5.10 *Partial Utilization, Acknowledgment of Property Insurer*

- A. If Owner finds it necessary to occupy or use a portion or portions of the Work prior to Substantial Completion of all the Work as provided in Paragraph 14.05, no such use or occupancy shall commence before the insurers providing the property insurance pursuant to Paragraph 5.06 have acknowledged notice thereof and in writing effected any changes in coverage necessitated thereby. The insurers providing the property insurance shall consent by endorsement on the policy or policies, but the property insurance shall not be canceled or permitted to lapse on account of any such partial use or occupancy.

**ARTICLE 6 – CONTRACTOR’S RESPONSIBILITIES**

6.01 *Supervision and Superintendence*

- A. Contractor shall supervise, inspect, and direct the Work competently and efficiently, devoting such attention thereto and applying such skills and expertise as may be necessary to perform the Work in accordance with the Contract Documents. Contractor shall be solely responsible for the means, methods, techniques, sequences, and procedures of construction. Contractor shall not be responsible for the negligence of Owner or Engineer in the design or specification of a specific means, method, technique, sequence, or procedure of construction which is shown or indicated in and expressly required by the Contract Documents.
- B. At all times during the progress of the Work, Contractor shall assign a competent resident superintendent who shall not be replaced without written notice to Owner and Engineer except under extraordinary circumstances.

6.02 *Labor; Working Hours*

- A. Contractor shall provide competent, suitably qualified personnel to survey and lay out the Work and perform construction as required by the Contract Documents. Contractor shall at all times maintain good discipline and order at the Site.
- B. Except as otherwise required for the safety or protection of persons or the Work or property at the Site or adjacent thereto, and except as otherwise stated in the Contract Documents, all Work at the Site shall be performed during regular working hours. Contractor will not permit the performance of Work on a Saturday, Sunday, or any legal holiday without Owner’s written consent (which will not be unreasonably withheld) given after prior written notice to Engineer.

6.03 *Services, Materials, and Equipment*

- A. Unless otherwise specified in the Contract Documents, Contractor shall provide and assume full responsibility for all services, materials, equipment, labor, transportation, construction equipment and machinery, tools, appliances, fuel, power, light, heat, telephone, water, sanitary facilities, temporary facilities, and all other facilities and incidentals necessary for the performance, testing, start-up, and completion of the Work.

- B. All materials and equipment incorporated into the Work shall be as specified or, if not specified, shall be of good quality and new, except as otherwise provided in the Contract Documents. All special warranties and guarantees required by the Specifications shall expressly run to the benefit of Owner. If required by Engineer, Contractor shall furnish satisfactory evidence (including reports of required tests) as to the source, kind, and quality of materials and equipment.
- C. All materials and equipment shall be stored, applied, installed, connected, erected, protected, used, cleaned, and conditioned in accordance with instructions of the applicable Supplier, except as otherwise may be provided in the Contract Documents.

#### 6.04 *Progress Schedule*

- A. Contractor shall adhere to the Progress Schedule established in accordance with Paragraph 2.07 as it may be adjusted from time to time as provided below.
  - 1. Contractor shall submit to Engineer for acceptance (to the extent indicated in Paragraph 2.07) proposed adjustments in the Progress Schedule that will not result in changing the Contract Times. Such adjustments will comply with any provisions of the General Requirements applicable thereto.
  - 2. Proposed adjustments in the Progress Schedule that will change the Contract Times shall be submitted in accordance with the requirements of Article 12. Adjustments in Contract Times may only be made by a Change Order.

#### 6.05 *Substitutes and "Or-Equals"*

- A. Whenever an item of material or equipment is specified or described in the Contract Documents by using the name of a proprietary item or the name of a particular Supplier, the specification or description is intended to establish the type, function, appearance, and quality required. Unless the specification or description contains or is followed by words reading that no like, equivalent, or "or-equal" item or no substitution is permitted, other items of material or equipment or material or equipment of other Suppliers may be submitted to Engineer for review under the circumstances described below.
  - 1. "*Or-Equal*" Items: If in Engineer's sole discretion an item of material or equipment proposed by Contractor is functionally equal to that named and sufficiently similar so that no change in related Work will be required, it may be considered by Engineer as an "or-equal" item, in which case review and approval of the proposed item may, in Engineer's sole discretion, be accomplished without compliance with some or all of the requirements for approval of proposed substitute items. For the purposes of this Paragraph 6.05.A.1, a proposed item of material or equipment will be considered functionally equal to an item so named if:
    - a. in the exercise of reasonable judgment Engineer determines that:
      - 1) it is at least equal in materials of construction, quality, durability, appearance, strength, and design characteristics;

- 2) it will reliably perform at least equally well the function and achieve the results imposed by the design concept of the completed Project as a functioning whole; and
  - 3) it has a proven record of performance and availability of responsive service.
- b. Contractor certifies that, if approved and incorporated into the Work:
- 1) there will be no increase in cost to the Owner or increase in Contract Times; and
  - 2) it will conform substantially to the detailed requirements of the item named in the Contract Documents.

2. *Substitute Items:*

- a. If in Engineer's sole discretion an item of material or equipment proposed by Contractor does not qualify as an "or-equal" item under Paragraph 6.05.A.1, it will be considered a proposed substitute item.
- b. Contractor shall submit sufficient information as provided below to allow Engineer to determine if the item of material or equipment proposed is essentially equivalent to that named and an acceptable substitute therefor. Requests for review of proposed substitute items of material or equipment will not be accepted by Engineer from anyone other than Contractor.
- c. The requirements for review by Engineer will be as set forth in Paragraph 6.05.A.2.d, as supplemented by the General Requirements, and as Engineer may decide is appropriate under the circumstances.
- d. Contractor shall make written application to Engineer for review of a proposed substitute item of material or equipment that Contractor seeks to furnish or use. The application:
  - 1) shall certify that the proposed substitute item will:
    - a) perform adequately the functions and achieve the results called for by the general design,
    - b) be similar in substance to that specified, and
    - c) be suited to the same use as that specified;
  - 2) will state:
    - a) the extent, if any, to which the use of the proposed substitute item will prejudice Contractor's achievement of Substantial Completion on time,
    - b) whether use of the proposed substitute item in the Work will require a change in any of the Contract Documents (or in the provisions of any other direct contract with Owner for other work on the Project) to adapt the design to the proposed substitute item, and

- c) whether incorporation or use of the proposed substitute item in connection with the Work is subject to payment of any license fee or royalty;
  - 3) will identify:
    - a) all variations of the proposed substitute item from that specified, and
    - b) available engineering, sales, maintenance, repair, and replacement services; and
  - 4) shall contain an itemized estimate of all costs or credits that will result directly or indirectly from use of such substitute item, including costs of redesign and claims of other contractors affected by any resulting change.
- B. *Substitute Construction Methods or Procedures:* If a specific means, method, technique, sequence, or procedure of construction is expressly required by the Contract Documents, Contractor may furnish or utilize a substitute means, method, technique, sequence, or procedure of construction approved by Engineer. Contractor shall submit sufficient information to allow Engineer, in Engineer's sole discretion, to determine that the substitute proposed is equivalent to that expressly called for by the Contract Documents. The requirements for review by Engineer will be similar to those provided in Paragraph 6.05.A.2.
- C. *Engineer's Evaluation:* Engineer will be allowed a reasonable time within which to evaluate each proposal or submittal made pursuant to Paragraphs 6.05.A and 6.05.B. Engineer may require Contractor to furnish additional data about the proposed substitute item. Engineer will be the sole judge of acceptability. No "or equal" or substitute will be ordered, installed or utilized until Engineer's review is complete, which will be evidenced by a Change Order in the case of a substitute and an approved Shop Drawing for an "or equal." Engineer will advise Contractor in writing of any negative determination.
- D. *Special Guarantee:* Owner may require Contractor to furnish at Contractor's expense a special performance guarantee or other surety with respect to any substitute.
- E. *Engineer's Cost Reimbursement:* Engineer will record Engineer's costs in evaluating a substitute proposed or submitted by Contractor pursuant to Paragraphs 6.05.A.2 and 6.05.B. Whether or not Engineer approves a substitute so proposed or submitted by Contractor, Contractor shall reimburse Owner for the reasonable charges of Engineer for evaluating each such proposed substitute. Contractor shall also reimburse Owner for the reasonable charges of Engineer for making changes in the Contract Documents (or in the provisions of any other direct contract with Owner) resulting from the acceptance of each proposed substitute.
- F. *Contractor's Expense:* Contractor shall provide all data in support of any proposed substitute or "or-equal" at Contractor's expense.

#### 6.06 *Concerning Subcontractors, Suppliers, and Others*

- A. Contractor shall not employ any Subcontractor, Supplier, or other individual or entity (including those acceptable to Owner as indicated in Paragraph 6.06.B), whether initially or as a replacement, against whom Owner may have reasonable objection. Contractor shall not be

required to employ any Subcontractor, Supplier, or other individual or entity to furnish or perform any of the Work against whom Contractor has reasonable objection.

- B. If the Supplementary Conditions require the identity of certain Subcontractors, Suppliers, or other individuals or entities to be submitted to Owner in advance for acceptance by Owner by a specified date prior to the Effective Date of the Agreement, and if Contractor has submitted a list thereof in accordance with the Supplementary Conditions, Owner's acceptance (either in writing or by failing to make written objection thereto by the date indicated for acceptance or objection in the Bidding Documents or the Contract Documents) of any such Subcontractor, Supplier, or other individual or entity so identified may be revoked on the basis of reasonable objection after due investigation. Contractor shall submit an acceptable replacement for the rejected Subcontractor, Supplier, or other individual or entity, and the Contract Price will be adjusted by the difference in the cost occasioned by such replacement, and an appropriate Change Order will be issued. No acceptance by Owner of any such Subcontractor, Supplier, or other individual or entity, whether initially or as a replacement, shall constitute a waiver of any right of Owner or Engineer to reject defective Work.
- C. Contractor shall be fully responsible to Owner and Engineer for all acts and omissions of the Subcontractors, Suppliers, and other individuals or entities performing or furnishing any of the Work just as Contractor is responsible for Contractor's own acts and omissions. Nothing in the Contract Documents:
1. shall create for the benefit of any such Subcontractor, Supplier, or other individual or entity any contractual relationship between Owner or Engineer and any such Subcontractor, Supplier or other individual or entity; nor
  2. shall create any obligation on the part of Owner or Engineer to pay or to see to the payment of any moneys due any such Subcontractor, Supplier, or other individual or entity except as may otherwise be required by Laws and Regulations.
- D. Contractor shall be solely responsible for scheduling and coordinating the Work of Subcontractors, Suppliers, and other individuals or entities performing or furnishing any of the Work under a direct or indirect contract with Contractor.
- E. Contractor shall require all Subcontractors, Suppliers, and such other individuals or entities performing or furnishing any of the Work to communicate with Engineer through Contractor.
- F. The divisions and sections of the Specifications and the identifications of any Drawings shall not control Contractor in dividing the Work among Subcontractors or Suppliers or delineating the Work to be performed by any specific trade.
- G. All Work performed for Contractor by a Subcontractor or Supplier will be pursuant to an appropriate agreement between Contractor and the Subcontractor or Supplier which specifically binds the Subcontractor or Supplier to the applicable terms and conditions of the Contract Documents for the benefit of Owner and Engineer. Whenever any such agreement is with a Subcontractor or Supplier who is listed as a loss payee on the property insurance provided in Paragraph 5.06, the agreement between the Contractor and the Subcontractor or Supplier will contain provisions whereby the Subcontractor or Supplier waives all rights against Owner,

Contractor, Engineer, and all other individuals or entities identified in the Supplementary Conditions to be listed as insureds or loss payees (and the officers, directors, members, partners, employees, agents, consultants, and subcontractors of each and any of them) for all losses and damages caused by, arising out of, relating to, or resulting from any of the perils or causes of loss covered by such policies and any other property insurance applicable to the Work. If the insurers on any such policies require separate waiver forms to be signed by any Subcontractor or Supplier, Contractor will obtain the same.

#### 6.07 *Patent Fees and Royalties*

- A. Contractor shall pay all license fees and royalties and assume all costs incident to the use in the performance of the Work or the incorporation in the Work of any invention, design, process, product, or device which is the subject of patent rights or copyrights held by others. If a particular invention, design, process, product, or device is specified in the Contract Documents for use in the performance of the Work and if, to the actual knowledge of Owner or Engineer, its use is subject to patent rights or copyrights calling for the payment of any license fee or royalty to others, the existence of such rights shall be disclosed by Owner in the Contract Documents.
- B. To the fullest extent permitted by Laws and Regulations, Owner shall indemnify and hold harmless Contractor, and its officers, directors, members, partners, employees, agents, consultants, and subcontractors from and against all claims, costs, losses, and damages (including but not limited to all fees and charges of engineers, architects, attorneys, and other professionals, and all court or arbitration or other dispute resolution costs) arising out of or relating to any infringement of patent rights or copyrights incident to the use in the performance of the Work or resulting from the incorporation in the Work of any invention, design, process, product, or device specified in the Contract Documents, but not identified as being subject to payment of any license fee or royalty to others required by patent rights or copyrights.
- C. To the fullest extent permitted by Laws and Regulations, Contractor shall indemnify and hold harmless Owner and Engineer, and the officers, directors, members, partners, employees, agents, consultants and subcontractors of each and any of them from and against all claims, costs, losses, and damages (including but not limited to all fees and charges of engineers, architects, attorneys, and other professionals and all court or arbitration or other dispute resolution costs) arising out of or relating to any infringement of patent rights or copyrights incident to the use in the performance of the Work or resulting from the incorporation in the Work of any invention, design, process, product, or device not specified in the Contract Documents.

#### 6.08 *Permits*

- A. Unless otherwise provided in the Supplementary Conditions, Contractor shall obtain and pay for all construction permits and licenses. Owner shall assist Contractor, when necessary, in obtaining such permits and licenses. Contractor shall pay all governmental charges and inspection fees necessary for the prosecution of the Work which are applicable at the time of opening of Bids, or, if there are no Bids, on the Effective Date of the Agreement. Owner shall pay all charges of utility owners for connections for providing permanent service to the Work.

## 6.09 *Laws and Regulations*

- A. Contractor shall give all notices required by and shall comply with all Laws and Regulations applicable to the performance of the Work. Except where otherwise expressly required by applicable Laws and Regulations, neither Owner nor Engineer shall be responsible for monitoring Contractor's compliance with any Laws or Regulations.
- B. If Contractor performs any Work knowing or having reason to know that it is contrary to Laws or Regulations, Contractor shall bear all claims, costs, losses, and damages (including but not limited to all fees and charges of engineers, architects, attorneys, and other professionals and all court or arbitration or other dispute resolution costs) arising out of or relating to such Work. However, it shall not be Contractor's responsibility to make certain that the Specifications and Drawings are in accordance with Laws and Regulations, but this shall not relieve Contractor of Contractor's obligations under Paragraph 3.03.
- C. Changes in Laws or Regulations not known at the time of opening of Bids (or, on the Effective Date of the Agreement if there were no Bids) having an effect on the cost or time of performance of the Work shall be the subject of an adjustment in Contract Price or Contract Times. If Owner and Contractor are unable to agree on entitlement to or on the amount or extent, if any, of any such adjustment, a Claim may be made therefor as provided in Paragraph 10.05.

## 6.10 *Taxes*

- A. Contractor shall pay all sales, consumer, use, and other similar taxes required to be paid by Contractor in accordance with the Laws and Regulations of the place of the Project which are applicable during the performance of the Work.

## 6.11 *Use of Site and Other Areas*

### A. *Limitation on Use of Site and Other Areas:*

- 1. Contractor shall confine construction equipment, the storage of materials and equipment, and the operations of workers to the Site and other areas permitted by Laws and Regulations, and shall not unreasonably encumber the Site and other areas with construction equipment or other materials or equipment. Contractor shall assume full responsibility for any damage to any such land or area, or to the owner or occupant thereof, or of any adjacent land or areas resulting from the performance of the Work.
- 2. Should any claim be made by any such owner or occupant because of the performance of the Work, Contractor shall promptly settle with such other party by negotiation or otherwise resolve the claim by arbitration or other dispute resolution proceeding or at law.
- 3. To the fullest extent permitted by Laws and Regulations, Contractor shall indemnify and hold harmless Owner and Engineer, and the officers, directors, members, partners, employees, agents, consultants and subcontractors of each and any of them from and against all claims, costs, losses, and damages (including but not limited to all fees and charges of engineers, architects, attorneys, and other professionals and all court or arbitration or other dispute resolution costs) arising out of or relating to any claim or action, legal or equitable, brought



by any such owner or occupant against Owner, Engineer, or any other party indemnified hereunder to the extent caused by or based upon Contractor's performance of the Work.

- B. *Removal of Debris During Performance of the Work:* During the progress of the Work Contractor shall keep the Site and other areas free from accumulations of waste materials, rubbish, and other debris. Removal and disposal of such waste materials, rubbish, and other debris shall conform to applicable Laws and Regulations.
- C. *Cleaning:* Prior to Substantial Completion of the Work Contractor shall clean the Site and the Work and make it ready for utilization by Owner. At the completion of the Work Contractor shall remove from the Site all tools, appliances, construction equipment and machinery, and surplus materials and shall restore to original condition all property not designated for alteration by the Contract Documents.
- D. *Loading Structures:* Contractor shall not load nor permit any part of any structure to be loaded in any manner that will endanger the structure, nor shall Contractor subject any part of the Work or adjacent property to stresses or pressures that will endanger it.

#### 6.12 *Record Documents*

- A. Contractor shall maintain in a safe place at the Site one record copy of all Drawings, Specifications, Addenda, Change Orders, Work Change Directives, Field Orders, and written interpretations and clarifications in good order and annotated to show changes made during construction. These record documents together with all approved Samples and a counterpart of all approved Shop Drawings will be available to Engineer for reference. Upon completion of the Work, these record documents, Samples, and Shop Drawings will be delivered to Engineer for Owner.

#### 6.13 *Safety and Protection*

- A. Contractor shall be solely responsible for initiating, maintaining and supervising all safety precautions and programs in connection with the Work. Such responsibility does not relieve Subcontractors of their responsibility for the safety of persons or property in the performance of their work, nor for compliance with applicable safety Laws and Regulations. Contractor shall take all necessary precautions for the safety of, and shall provide the necessary protection to prevent damage, injury or loss to:
  - 1. all persons on the Site or who may be affected by the Work;
  - 2. all the Work and materials and equipment to be incorporated therein, whether in storage on or off the Site; and
  - 3. other property at the Site or adjacent thereto, including trees, shrubs, lawns, walks, pavements, roadways, structures, utilities, and Underground Facilities not designated for removal, relocation, or replacement in the course of construction.
- B. Contractor shall comply with all applicable Laws and Regulations relating to the safety of persons or property, or to the protection of persons or property from damage, injury, or loss; and

shall erect and maintain all necessary safeguards for such safety and protection. Contractor shall notify owners of adjacent property and of Underground Facilities and other utility owners when prosecution of the Work may affect them, and shall cooperate with them in the protection, removal, relocation, and replacement of their property.

- C. Contractor shall comply with the applicable requirements of Owner's safety programs, if any. The Supplementary Conditions identify any Owner's safety programs that are applicable to the Work.
- D. Contractor shall inform Owner and Engineer of the specific requirements of Contractor's safety program with which Owner's and Engineer's employees and representatives must comply while at the Site.
- E. All damage, injury, or loss to any property referred to in Paragraph 6.13.A.2 or 6.13.A.3 caused, directly or indirectly, in whole or in part, by Contractor, any Subcontractor, Supplier, or any other individual or entity directly or indirectly employed by any of them to perform any of the Work, or anyone for whose acts any of them may be liable, shall be remedied by Contractor (except damage or loss attributable to the fault of Drawings or Specifications or to the acts or omissions of Owner or Engineer or anyone employed by any of them, or anyone for whose acts any of them may be liable, and not attributable, directly or indirectly, in whole or in part, to the fault or negligence of Contractor or any Subcontractor, Supplier, or other individual or entity directly or indirectly employed by any of them).
- F. Contractor's duties and responsibilities for safety and for protection of the Work shall continue until such time as all the Work is completed and Engineer has issued a notice to Owner and Contractor in accordance with Paragraph 14.07.B that the Work is acceptable (except as otherwise expressly provided in connection with Substantial Completion).

#### 6.14 *Safety Representative*

- A. Contractor shall designate a qualified and experienced safety representative at the Site whose duties and responsibilities shall be the prevention of accidents and the maintaining and supervising of safety precautions and programs.

#### 6.15 *Hazard Communication Programs*

- A. Contractor shall be responsible for coordinating any exchange of material safety data sheets or other hazard communication information required to be made available to or exchanged between or among employers at the Site in accordance with Laws or Regulations.

#### 6.16 *Emergencies*

- A. In emergencies affecting the safety or protection of persons or the Work or property at the Site or adjacent thereto, Contractor is obligated to act to prevent threatened damage, injury, or loss. Contractor shall give Engineer prompt written notice if Contractor believes that any significant changes in the Work or variations from the Contract Documents have been caused thereby or are required as a result thereof. If Engineer determines that a change in the Contract Documents is

required because of the action taken by Contractor in response to such an emergency, a Work Change Directive or Change Order will be issued.

#### 6.17 *Shop Drawings and Samples*

A. Contractor shall submit Shop Drawings and Samples to Engineer for review and approval in accordance with the accepted Schedule of Submittals (as required by Paragraph 2.07). Each submittal will be identified as Engineer may require.

##### 1. *Shop Drawings:*

- a. Submit number of copies specified in the General Requirements.
- b. Data shown on the Shop Drawings will be complete with respect to quantities, dimensions, specified performance and design criteria, materials, and similar data to show Engineer the services, materials, and equipment Contractor proposes to provide and to enable Engineer to review the information for the limited purposes required by Paragraph 6.17.D.

##### 2. *Samples:*

- a. Submit number of Samples specified in the Specifications.
- b. Clearly identify each Sample as to material, Supplier, pertinent data such as catalog numbers, the use for which intended and other data as Engineer may require to enable Engineer to review the submittal for the limited purposes required by Paragraph 6.17.D.

B. Where a Shop Drawing or Sample is required by the Contract Documents or the Schedule of Submittals, any related Work performed prior to Engineer's review and approval of the pertinent submittal will be at the sole expense and responsibility of Contractor.

##### C. *Submittal Procedures:*

1. Before submitting each Shop Drawing or Sample, Contractor shall have:

- a. reviewed and coordinated each Shop Drawing or Sample with other Shop Drawings and Samples and with the requirements of the Work and the Contract Documents;
- b. determined and verified all field measurements, quantities, dimensions, specified performance and design criteria, installation requirements, materials, catalog numbers, and similar information with respect thereto;
- c. determined and verified the suitability of all materials offered with respect to the indicated application, fabrication, shipping, handling, storage, assembly, and installation pertaining to the performance of the Work; and
- d. determined and verified all information relative to Contractor's responsibilities for means, methods, techniques, sequences, and procedures of construction, and safety precautions and programs incident thereto.

2. Each submittal shall bear a stamp or specific written certification that Contractor has satisfied Contractor's obligations under the Contract Documents with respect to Contractor's review and approval of that submittal.
3. With each submittal, Contractor shall give Engineer specific written notice of any variations that the Shop Drawing or Sample may have from the requirements of the Contract Documents. This notice shall be both a written communication separate from the Shop Drawings or Sample submittal; and, in addition, by a specific notation made on each Shop Drawing or Sample submitted to Engineer for review and approval of each such variation.

D. *Engineer's Review:*

1. Engineer will provide timely review of Shop Drawings and Samples in accordance with the Schedule of Submittals acceptable to Engineer. Engineer's review and approval will be only to determine if the items covered by the submittals will, after installation or incorporation in the Work, conform to the information given in the Contract Documents and be compatible with the design concept of the completed Project as a functioning whole as indicated by the Contract Documents.
2. Engineer's review and approval will not extend to means, methods, techniques, sequences, or procedures of construction (except where a particular means, method, technique, sequence, or procedure of construction is specifically and expressly called for by the Contract Documents) or to safety precautions or programs incident thereto. The review and approval of a separate item as such will not indicate approval of the assembly in which the item functions.
3. Engineer's review and approval shall not relieve Contractor from responsibility for any variation from the requirements of the Contract Documents unless Contractor has complied with the requirements of Paragraph 6.17.C.3 and Engineer has given written approval of each such variation by specific written notation thereof incorporated in or accompanying the Shop Drawing or Sample. Engineer's review and approval shall not relieve Contractor from responsibility for complying with the requirements of Paragraph 6.17.C.1.

E. *Resubmittal Procedures:*

1. Contractor shall make corrections required by Engineer and shall return the required number of corrected copies of Shop Drawings and submit, as required, new Samples for review and approval. Contractor shall direct specific attention in writing to revisions other than the corrections called for by Engineer on previous submittals.

6.18 *Continuing the Work*

- A. Contractor shall carry on the Work and adhere to the Progress Schedule during all disputes or disagreements with Owner. No Work shall be delayed or postponed pending resolution of any disputes or disagreements, except as permitted by Paragraph 15.04 or as Owner and Contractor may otherwise agree in writing.

6.19 *Contractor's General Warranty and Guarantee*

- A. Contractor warrants and guarantees to Owner that all Work will be in accordance with the Contract Documents and will not be defective. Engineer and its officers, directors, members, partners, employees, agents, consultants, and subcontractors shall be entitled to rely on representation of Contractor's warranty and guarantee.
- B. Contractor's warranty and guarantee hereunder excludes defects or damage caused by:
1. abuse, modification, or improper maintenance or operation by persons other than Contractor, Subcontractors, Suppliers, or any other individual or entity for whom Contractor is responsible; or
  2. normal wear and tear under normal usage.
- C. Contractor's obligation to perform and complete the Work in accordance with the Contract Documents shall be absolute. None of the following will constitute an acceptance of Work that is not in accordance with the Contract Documents or a release of Contractor's obligation to perform the Work in accordance with the Contract Documents:
1. observations by Engineer;
  2. recommendation by Engineer or payment by Owner of any progress or final payment;
  3. the issuance of a certificate of Substantial Completion by Engineer or any payment related thereto by Owner;
  4. use or occupancy of the Work or any part thereof by Owner;
  5. any review and approval of a Shop Drawing or Sample submittal or the issuance of a notice of acceptability by Engineer;
  6. any inspection, test, or approval by others; or
  7. any correction of defective Work by Owner.

6.20 *Indemnification*

- A. To the fullest extent permitted by Laws and Regulations, Contractor shall indemnify and hold harmless Owner and Engineer, and the officers, directors, members, partners, employees, agents, consultants and subcontractors of each and any of them from and against all claims, costs, losses, and damages (including but not limited to all fees and charges of engineers, architects, attorneys, and other professionals and all court or arbitration or other dispute resolution costs) arising out of or relating to the performance of the Work, provided that any such claim, cost, loss, or damage is attributable to bodily injury, sickness, disease, or death, or to injury to or destruction of tangible property (other than the Work itself), including the loss of use resulting therefrom but only to the extent caused by any negligent act or omission of Contractor, any Subcontractor, any Supplier, or any individual or entity directly or indirectly employed by any of them to perform any of the Work or anyone for whose acts any of them may be liable .

- B. In any and all claims against Owner or Engineer or any of their officers, directors, members, partners, employees, agents, consultants, or subcontractors by any employee (or the survivor or personal representative of such employee) of Contractor, any Subcontractor, any Supplier, or any individual or entity directly or indirectly employed by any of them to perform any of the Work, or anyone for whose acts any of them may be liable, the indemnification obligation under Paragraph 6.20.A shall not be limited in any way by any limitation on the amount or type of damages, compensation, or benefits payable by or for Contractor or any such Subcontractor, Supplier, or other individual or entity under workers' compensation acts, disability benefit acts, or other employee benefit acts.
- C. The indemnification obligations of Contractor under Paragraph 6.20.A shall not extend to the liability of Engineer and Engineer's officers, directors, members, partners, employees, agents, consultants and subcontractors arising out of:
  - 1. the preparation or approval of, or the failure to prepare or approve maps, Drawings, opinions, reports, surveys, Change Orders, designs, or Specifications; or
  - 2. giving directions or instructions, or failing to give them, if that is the primary cause of the injury or damage.

6.21 *Delegation of Professional Design Services*

- A. Contractor will not be required to provide professional design services unless such services are specifically required by the Contract Documents for a portion of the Work or unless such services are required to carry out Contractor's responsibilities for construction means, methods, techniques, sequences and procedures. Contractor shall not be required to provide professional services in violation of applicable law.
- B. If professional design services or certifications by a design professional related to systems, materials or equipment are specifically required of Contractor by the Contract Documents, Owner and Engineer will specify all performance and design criteria that such services must satisfy. Contractor shall cause such services or certifications to be provided by a properly licensed professional, whose signature and seal shall appear on all drawings, calculations, specifications, certifications, Shop Drawings and other submittals prepared by such professional. Shop Drawings and other submittals related to the Work designed or certified by such professional, if prepared by others, shall bear such professional's written approval when submitted to Engineer.
- C. Owner and Engineer shall be entitled to rely upon the adequacy, accuracy and completeness of the services, certifications or approvals performed by such design professionals, provided Owner and Engineer have specified to Contractor all performance and design criteria that such services must satisfy.
- D. Pursuant to this Paragraph 6.21, Engineer's review and approval of design calculations and design drawings will be only for the limited purpose of checking for conformance with performance and design criteria given and the design concept expressed in the Contract Documents. Engineer's review and approval of Shop Drawings and other submittals (except design calculations and design drawings) will be only for the purpose stated in Paragraph 6.17.D.1.

- E. Contractor shall not be responsible for the adequacy of the performance or design criteria required by the Contract Documents.

## ARTICLE 7 – OTHER WORK AT THE SITE

### 7.01 *Related Work at Site*

- A. Owner may perform other work related to the Project at the Site with Owner's employees, or through other direct contracts therefor, or have other work performed by utility owners. If such other work is not noted in the Contract Documents, then:
  - 1. written notice thereof will be given to Contractor prior to starting any such other work; and
  - 2. if Owner and Contractor are unable to agree on entitlement to or on the amount or extent, if any, of any adjustment in the Contract Price or Contract Times that should be allowed as a result of such other work, a Claim may be made therefor as provided in Paragraph 10.05.
- B. Contractor shall afford each other contractor who is a party to such a direct contract, each utility owner, and Owner, if Owner is performing other work with Owner's employees, proper and safe access to the Site, provide a reasonable opportunity for the introduction and storage of materials and equipment and the execution of such other work, and properly coordinate the Work with theirs. Contractor shall do all cutting, fitting, and patching of the Work that may be required to properly connect or otherwise make its several parts come together and properly integrate with such other work. Contractor shall not endanger any work of others by cutting, excavating, or otherwise altering such work; provided, however, that Contractor may cut or alter others' work with the written consent of Engineer and the others whose work will be affected. The duties and responsibilities of Contractor under this Paragraph are for the benefit of such utility owners and other contractors to the extent that there are comparable provisions for the benefit of Contractor in said direct contracts between Owner and such utility owners and other contractors.
- C. If the proper execution or results of any part of Contractor's Work depends upon work performed by others under this Article 7, Contractor shall inspect such other work and promptly report to Engineer in writing any delays, defects, or deficiencies in such other work that render it unavailable or unsuitable for the proper execution and results of Contractor's Work. Contractor's failure to so report will constitute an acceptance of such other work as fit and proper for integration with Contractor's Work except for latent defects and deficiencies in such other work.

### 7.02 *Coordination*

- A. If Owner intends to contract with others for the performance of other work on the Project at the Site, the following will be set forth in Supplementary Conditions:
  - 1. the individual or entity who will have authority and responsibility for coordination of the activities among the various contractors will be identified;
  - 2. the specific matters to be covered by such authority and responsibility will be itemized; and
  - 3. the extent of such authority and responsibilities will be provided.

- B. Unless otherwise provided in the Supplementary Conditions, Owner shall have sole authority and responsibility for such coordination.

### 7.03 *Legal Relationships*

- A. Paragraphs 7.01.A and 7.02 are not applicable for utilities not under the control of Owner.
- B. Each other direct contract of Owner under Paragraph 7.01.A shall provide that the other contractor is liable to Owner and Contractor for the reasonable direct delay and disruption costs incurred by Contractor as a result of the other contractor's wrongful actions or inactions.
- C. Contractor shall be liable to Owner and any other contractor under direct contract to Owner for the reasonable direct delay and disruption costs incurred by such other contractor as a result of Contractor's wrongful action or inactions.

## **ARTICLE 8 – OWNER'S RESPONSIBILITIES**

### 8.01 *Communications to Contractor*

- A. Except as otherwise provided in these General Conditions, Owner shall issue all communications to Contractor through Engineer.

### 8.02 *Replacement of Engineer*

- A. In case of termination of the employment of Engineer, Owner shall appoint an engineer to whom Contractor makes no reasonable objection, whose status under the Contract Documents shall be that of the former Engineer.

### 8.03 *Furnish Data*

- A. Owner shall promptly furnish the data required of Owner under the Contract Documents.

### 8.04 *Pay When Due*

- A. Owner shall make payments to Contractor when they are due as provided in Paragraphs 14.02.C and 14.07.C.

### 8.05 *Lands and Easements; Reports and Tests*

- A. Owner's duties with respect to providing lands and easements and providing engineering surveys to establish reference points are set forth in Paragraphs 4.01 and 4.05. Paragraph 4.02 refers to Owner's identifying and making available to Contractor copies of reports of explorations and tests of subsurface conditions and drawings of physical conditions relating to existing surface or subsurface structures at the Site.

### 8.06 *Insurance*

- A. Owner's responsibilities, if any, with respect to purchasing and maintaining liability and property insurance are set forth in Article 5.



8.07 *Change Orders*

A. Owner is obligated to execute Change Orders as indicated in Paragraph 10.03.

8.08 *Inspections, Tests, and Approvals*

A. Owner's responsibility with respect to certain inspections, tests, and approvals is set forth in Paragraph 13.03.B.

8.09 *Limitations on Owner's Responsibilities*

A. The Owner shall not supervise, direct, or have control or authority over, nor be responsible for, Contractor's means, methods, techniques, sequences, or procedures of construction, or the safety precautions and programs incident thereto, or for any failure of Contractor to comply with Laws and Regulations applicable to the performance of the Work. Owner will not be responsible for Contractor's failure to perform the Work in accordance with the Contract Documents.

8.10 *Undisclosed Hazardous Environmental Condition*

A. Owner's responsibility in respect to an undisclosed Hazardous Environmental Condition is set forth in Paragraph 4.06.

8.11 *Evidence of Financial Arrangements*

A. Upon request of Contractor, Owner shall furnish Contractor reasonable evidence that financial arrangements have been made to satisfy Owner's obligations under the Contract Documents.

8.12 *Compliance with Safety Program*

A. While at the Site, Owner's employees and representatives shall comply with the specific applicable requirements of Contractor's safety programs of which Owner has been informed pursuant to Paragraph 6.13.D.

**ARTICLE 9 – ENGINEER'S STATUS DURING CONSTRUCTION**

9.01 *Owner's Representative*

A. Engineer will be Owner's representative during the construction period. The duties and responsibilities and the limitations of authority of Engineer as Owner's representative during construction are set forth in the Contract Documents.

9.02 *Visits to Site*

A. Engineer will make visits to the Site at intervals appropriate to the various stages of construction as Engineer deems necessary in order to observe as an experienced and qualified design professional the progress that has been made and the quality of the various aspects of Contractor's executed Work. Based on information obtained during such visits and observations, Engineer, for the benefit of Owner, will determine, in general, if the Work is proceeding in accordance with the Contract Documents. Engineer will not be required to make exhaustive or

continuous inspections on the Site to check the quality or quantity of the Work. Engineer's efforts will be directed toward providing for Owner a greater degree of confidence that the completed Work will conform generally to the Contract Documents. On the basis of such visits and observations, Engineer will keep Owner informed of the progress of the Work and will endeavor to guard Owner against defective Work.

- B. Engineer's visits and observations are subject to all the limitations on Engineer's authority and responsibility set forth in Paragraph 9.09. Particularly, but without limitation, during or as a result of Engineer's visits or observations of Contractor's Work, Engineer will not supervise, direct, control, or have authority over or be responsible for Contractor's means, methods, techniques, sequences, or procedures of construction, or the safety precautions and programs incident thereto, or for any failure of Contractor to comply with Laws and Regulations applicable to the performance of the Work.

### 9.03 *Project Representative*

- A. If Owner and Engineer agree, Engineer will furnish a Resident Project Representative to assist Engineer in providing more extensive observation of the Work. The authority and responsibilities of any such Resident Project Representative and assistants will be as provided in the Supplementary Conditions, and limitations on the responsibilities thereof will be as provided in Paragraph 9.09. If Owner designates another representative or agent to represent Owner at the Site who is not Engineer's consultant, agent or employee, the responsibilities and authority and limitations thereon of such other individual or entity will be as provided in the Supplementary Conditions.

### 9.04 *Authorized Variations in Work*

- A. Engineer may authorize minor variations in the Work from the requirements of the Contract Documents which do not involve an adjustment in the Contract Price or the Contract Times and are compatible with the design concept of the completed Project as a functioning whole as indicated by the Contract Documents. These may be accomplished by a Field Order and will be binding on Owner and also on Contractor, who shall perform the Work involved promptly. If Owner or Contractor believes that a Field Order justifies an adjustment in the Contract Price or Contract Times, or both, and the parties are unable to agree on entitlement to or on the amount or extent, if any, of any such adjustment, a Claim may be made therefor as provided in Paragraph 10.05.

### 9.05 *Rejecting Defective Work*

- A. Engineer will have authority to reject Work which Engineer believes to be defective, or that Engineer believes will not produce a completed Project that conforms to the Contract Documents or that will prejudice the integrity of the design concept of the completed Project as a functioning whole as indicated by the Contract Documents. Engineer will also have authority to require special inspection or testing of the Work as provided in Paragraph 13.04, whether or not the Work is fabricated, installed, or completed.

9.06 *Shop Drawings, Change Orders and Payments*

- A. In connection with Engineer's authority, and limitations thereof, as to Shop Drawings and Samples, see Paragraph 6.17.
- B. In connection with Engineer's authority, and limitations thereof, as to design calculations and design drawings submitted in response to a delegation of professional design services, if any, see Paragraph 6.21.
- C. In connection with Engineer's authority as to Change Orders, see Articles 10, 11, and 12.
- D. In connection with Engineer's authority as to Applications for Payment, see Article 14.

9.07 *Determinations for Unit Price Work*

- A. Engineer will determine the actual quantities and classifications of Unit Price Work performed by Contractor. Engineer will review with Contractor the Engineer's preliminary determinations on such matters before rendering a written decision thereon (by recommendation of an Application for Payment or otherwise). Engineer's written decision thereon will be final and binding (except as modified by Engineer to reflect changed factual conditions or more accurate data) upon Owner and Contractor, subject to the provisions of Paragraph 10.05.

9.08 *Decisions on Requirements of Contract Documents and Acceptability of Work*

- A. Engineer will be the initial interpreter of the requirements of the Contract Documents and judge of the acceptability of the Work thereunder. All matters in question and other matters between Owner and Contractor arising prior to the date final payment is due relating to the acceptability of the Work, and the interpretation of the requirements of the Contract Documents pertaining to the performance of the Work, will be referred initially to Engineer in writing within 30 days of the event giving rise to the question.
- B. Engineer will, with reasonable promptness, render a written decision on the issue referred. If Owner or Contractor believes that any such decision entitles them to an adjustment in the Contract Price or Contract Times or both, a Claim may be made under Paragraph 10.05. The date of Engineer's decision shall be the date of the event giving rise to the issues referenced for the purposes of Paragraph 10.05.B.
- C. Engineer's written decision on the issue referred will be final and binding on Owner and Contractor, subject to the provisions of Paragraph 10.05.
- D. When functioning as interpreter and judge under this Paragraph 9.08, Engineer will not show partiality to Owner or Contractor and will not be liable in connection with any interpretation or decision rendered in good faith in such capacity.

9.09 *Limitations on Engineer's Authority and Responsibilities*

- A. Neither Engineer's authority or responsibility under this Article 9 or under any other provision of the Contract Documents nor any decision made by Engineer in good faith either to exercise or not

exercise such authority or responsibility or the undertaking, exercise, or performance of any authority or responsibility by Engineer shall create, impose, or give rise to any duty in contract, tort, or otherwise owed by Engineer to Contractor, any Subcontractor, any Supplier, any other individual or entity, or to any surety for or employee or agent of any of them.

- B. Engineer will not supervise, direct, control, or have authority over or be responsible for Contractor's means, methods, techniques, sequences, or procedures of construction, or the safety precautions and programs incident thereto, or for any failure of Contractor to comply with Laws and Regulations applicable to the performance of the Work. Engineer will not be responsible for Contractor's failure to perform the Work in accordance with the Contract Documents.
- C. Engineer will not be responsible for the acts or omissions of Contractor or of any Subcontractor, any Supplier, or of any other individual or entity performing any of the Work.
- D. Engineer's review of the final Application for Payment and accompanying documentation and all maintenance and operating instructions, schedules, guarantees, bonds, certificates of inspection, tests and approvals, and other documentation required to be delivered by Paragraph 14.07.A will only be to determine generally that their content complies with the requirements of, and in the case of certificates of inspections, tests, and approvals that the results certified indicate compliance with, the Contract Documents.
- E. The limitations upon authority and responsibility set forth in this Paragraph 9.09 shall also apply to the Resident Project Representative, if any, and assistants, if any.

#### 9.10 *Compliance with Safety Program*

- A. While at the Site, Engineer's employees and representatives shall comply with the specific applicable requirements of Contractor's safety programs of which Engineer has been informed pursuant to Paragraph 6.13.D.

### **ARTICLE 10 – CHANGES IN THE WORK; CLAIMS**

#### 10.01 *Authorized Changes in the Work*

- A. Without invalidating the Contract and without notice to any surety, Owner may, at any time or from time to time, order additions, deletions, or revisions in the Work by a Change Order, or a Work Change Directive. Upon receipt of any such document, Contractor shall promptly proceed with the Work involved which will be performed under the applicable conditions of the Contract Documents (except as otherwise specifically provided).
- B. If Owner and Contractor are unable to agree on entitlement to, or on the amount or extent, if any, of an adjustment in the Contract Price or Contract Times, or both, that should be allowed as a result of a Work Change Directive, a Claim may be made therefore as provided in Paragraph 10.05.

#### 10.02 *Unauthorized Changes in the Work*

- A. Contractor shall not be entitled to an increase in the Contract Price or an extension of the Contract Times with respect to any work performed that is not required by the Contract Documents as amended, modified, or supplemented as provided in Paragraph 3.04, except in the case of an emergency as provided in Paragraph 6.16 or in the case of uncovering Work as provided in Paragraph 13.04.D.

#### 10.03 *Execution of Change Orders*

- A. Owner and Contractor shall execute appropriate Change Orders recommended by Engineer covering:
  - 1. changes in the Work which are: (i) ordered by Owner pursuant to Paragraph 10.01.A, (ii) required because of acceptance of defective Work under Paragraph 13.08.A or Owner's correction of defective Work under Paragraph 13.09, or (iii) agreed to by the parties;
  - 2. changes in the Contract Price or Contract Times which are agreed to by the parties, including any undisputed sum or amount of time for Work actually performed in accordance with a Work Change Directive; and
  - 3. changes in the Contract Price or Contract Times which embody the substance of any written decision rendered by Engineer pursuant to Paragraph 10.05; provided that, in lieu of executing any such Change Order, an appeal may be taken from any such decision in accordance with the provisions of the Contract Documents and applicable Laws and Regulations, but during any such appeal, Contractor shall carry on the Work and adhere to the Progress Schedule as provided in Paragraph 6.18.A.

#### 10.04 *Notification to Surety*

- A. If the provisions of any bond require notice to be given to a surety of any change affecting the general scope of the Work or the provisions of the Contract Documents (including, but not limited to, Contract Price or Contract Times), the giving of any such notice will be Contractor's responsibility. The amount of each applicable bond will be adjusted to reflect the effect of any such change.

#### 10.05 *Claims*

- A. *Engineer's Decision Required:* All Claims, except those waived pursuant to Paragraph 14.09, shall be referred to the Engineer for decision. A decision by Engineer shall be required as a condition precedent to any exercise by Owner or Contractor of any rights or remedies either may otherwise have under the Contract Documents or by Laws and Regulations in respect of such Claims.
- B. *Notice:* Written notice stating the general nature of each Claim shall be delivered by the claimant to Engineer and the other party to the Contract promptly (but in no event later than 30 days) after the start of the event giving rise thereto. The responsibility to substantiate a Claim shall rest with the party making the Claim. Notice of the amount or extent of the Claim, with supporting data

shall be delivered to the Engineer and the other party to the Contract within 60 days after the start of such event (unless Engineer allows additional time for claimant to submit additional or more accurate data in support of such Claim). A Claim for an adjustment in Contract Price shall be prepared in accordance with the provisions of Paragraph 12.01.B. A Claim for an adjustment in Contract Times shall be prepared in accordance with the provisions of Paragraph 12.02.B. Each Claim shall be accompanied by claimant's written statement that the adjustment claimed is the entire adjustment to which the claimant believes it is entitled as a result of said event. The opposing party shall submit any response to Engineer and the claimant within 30 days after receipt of the claimant's last submittal (unless Engineer allows additional time).

- C. *Engineer's Action:* Engineer will review each Claim and, within 30 days after receipt of the last submittal of the claimant or the last submittal of the opposing party, if any, take one of the following actions in writing:
1. deny the Claim in whole or in part;
  2. approve the Claim; or
  3. notify the parties that the Engineer is unable to resolve the Claim if, in the Engineer's sole discretion, it would be inappropriate for the Engineer to do so. For purposes of further resolution of the Claim, such notice shall be deemed a denial.
- D. In the event that Engineer does not take action on a Claim within said 30 days, the Claim shall be deemed denied.
- E. Engineer's written action under Paragraph 10.05.C or denial pursuant to Paragraphs 10.05.C.3 or 10.05.D will be final and binding upon Owner and Contractor, unless Owner or Contractor invoke the dispute resolution procedure set forth in Article 16 within 30 days of such action or denial.
- F. No Claim for an adjustment in Contract Price or Contract Times will be valid if not submitted in accordance with this Paragraph 10.05.

## **ARTICLE 11 – COST OF THE WORK; ALLOWANCES; UNIT PRICE WORK**

### **11.01 *Cost of the Work***

- A. *Costs Included:* The term Cost of the Work means the sum of all costs, except those excluded in Paragraph 11.01.B, necessarily incurred and paid by Contractor in the proper performance of the Work. When the value of any Work covered by a Change Order or when a Claim for an adjustment in Contract Price is determined on the basis of Cost of the Work, the costs to be reimbursed to Contractor will be only those additional or incremental costs required because of the change in the Work or because of the event giving rise to the Claim. Except as otherwise may be agreed to in writing by Owner, such costs shall be in amounts no higher than those prevailing in the locality of the Project, shall not include any of the costs itemized in Paragraph 11.01.B, and shall include only the following items:

1. Payroll costs for employees in the direct employ of Contractor in the performance of the Work under schedules of job classifications agreed upon by Owner and Contractor. Such employees shall include, without limitation, superintendents, foremen, and other personnel employed full time on the Work. Payroll costs for employees not employed full time on the Work shall be apportioned on the basis of their time spent on the Work. Payroll costs shall include, but not be limited to, salaries and wages plus the cost of fringe benefits, which shall include social security contributions, unemployment, excise, and payroll taxes, workers' compensation, health and retirement benefits, bonuses, sick leave, vacation and holiday pay applicable thereto. The expenses of performing Work outside of regular working hours, on Saturday, Sunday, or legal holidays, shall be included in the above to the extent authorized by Owner.
2. Cost of all materials and equipment furnished and incorporated in the Work, including costs of transportation and storage thereof, and Suppliers' field services required in connection therewith. All cash discounts shall accrue to Contractor unless Owner deposits funds with Contractor with which to make payments, in which case the cash discounts shall accrue to Owner. All trade discounts, rebates and refunds and returns from sale of surplus materials and equipment shall accrue to Owner, and Contractor shall make provisions so that they may be obtained.
3. Payments made by Contractor to Subcontractors for Work performed by Subcontractors. If required by Owner, Contractor shall obtain competitive bids from subcontractors acceptable to Owner and Contractor and shall deliver such bids to Owner, who will then determine, with the advice of Engineer, which bids, if any, will be acceptable. If any subcontract provides that the Subcontractor is to be paid on the basis of Cost of the Work plus a fee, the Subcontractor's Cost of the Work and fee shall be determined in the same manner as Contractor's Cost of the Work and fee as provided in this Paragraph 11.01.
4. Costs of special consultants (including but not limited to engineers, architects, testing laboratories, surveyors, attorneys, and accountants) employed for services specifically related to the Work.
5. Supplemental costs including the following:
  - a. The proportion of necessary transportation, travel, and subsistence expenses of Contractor's employees incurred in discharge of duties connected with the Work.
  - b. Cost, including transportation and maintenance, of all materials, supplies, equipment, machinery, appliances, office, and temporary facilities at the Site, and hand tools not owned by the workers, which are consumed in the performance of the Work, and cost, less market value, of such items used but not consumed which remain the property of Contractor.
  - c. Rentals of all construction equipment and machinery, and the parts thereof whether rented from Contractor or others in accordance with rental agreements approved by Owner with the advice of Engineer, and the costs of transportation, loading, unloading, assembly, dismantling, and removal thereof. All such costs shall be in accordance with the terms of

said rental agreements. The rental of any such equipment, machinery, or parts shall cease when the use thereof is no longer necessary for the Work.

- d. Sales, consumer, use, and other similar taxes related to the Work, and for which Contractor is liable, as imposed by Laws and Regulations.
- e. Deposits lost for causes other than negligence of Contractor, any Subcontractor, or anyone directly or indirectly employed by any of them or for whose acts any of them may be liable, and royalty payments and fees for permits and licenses.
- f. Losses and damages (and related expenses) caused by damage to the Work, not compensated by insurance or otherwise, sustained by Contractor in connection with the performance of the Work (except losses and damages within the deductible amounts of property insurance established in accordance with Paragraph 5.06.D), provided such losses and damages have resulted from causes other than the negligence of Contractor, any Subcontractor, or anyone directly or indirectly employed by any of them or for whose acts any of them may be liable. Such losses shall include settlements made with the written consent and approval of Owner. No such losses, damages, and expenses shall be included in the Cost of the Work for the purpose of determining Contractor's fee.
- g. The cost of utilities, fuel, and sanitary facilities at the Site.
- h. Minor expenses such as telegrams, long distance telephone calls, telephone service at the Site, express and courier services, and similar petty cash items in connection with the Work.
- i. The costs of premiums for all bonds and insurance Contractor is required by the Contract Documents to purchase and maintain.

B. *Costs Excluded:* The term Cost of the Work shall not include any of the following items:

1. Payroll costs and other compensation of Contractor's officers, executives, principals (of partnerships and sole proprietorships), general managers, safety managers, engineers, architects, estimators, attorneys, auditors, accountants, purchasing and contracting agents, expeditors, timekeepers, clerks, and other personnel employed by Contractor, whether at the Site or in Contractor's principal or branch office for general administration of the Work and not specifically included in the agreed upon schedule of job classifications referred to in Paragraph 11.01.A.1 or specifically covered by Paragraph 11.01.A.4, all of which are to be considered administrative costs covered by the Contractor's fee.
2. Expenses of Contractor's principal and branch offices other than Contractor's office at the Site.
3. Any part of Contractor's capital expenses, including interest on Contractor's capital employed for the Work and charges against Contractor for delinquent payments.
4. Costs due to the negligence of Contractor, any Subcontractor, or anyone directly or indirectly employed by any of them or for whose acts any of them may be liable, including but not



limited to, the correction of defective Work, disposal of materials or equipment wrongly supplied, and making good any damage to property.

5. Other overhead or general expense costs of any kind and the costs of any item not specifically and expressly included in Paragraphs 11.01.A.
- C. *Contractor's Fee:* When all the Work is performed on the basis of cost-plus, Contractor's fee shall be determined as set forth in the Agreement. When the value of any Work covered by a Change Order or when a Claim for an adjustment in Contract Price is determined on the basis of Cost of the Work, Contractor's fee shall be determined as set forth in Paragraph 12.01.C.
- D. *Documentation:* Whenever the Cost of the Work for any purpose is to be determined pursuant to Paragraphs 11.01.A and 11.01.B, Contractor will establish and maintain records thereof in accordance with generally accepted accounting practices and submit in a form acceptable to Engineer an itemized cost breakdown together with supporting data.

#### 11.02 *Allowances*

- A. It is understood that Contractor has included in the Contract Price all allowances so named in the Contract Documents and shall cause the Work so covered to be performed for such sums and by such persons or entities as may be acceptable to Owner and Engineer.
- B. *Cash Allowances:*
1. Contractor agrees that:
    - a. the cash allowances include the cost to Contractor (less any applicable trade discounts) of materials and equipment required by the allowances to be delivered at the Site, and all applicable taxes; and
    - b. Contractor's costs for unloading and handling on the Site, labor, installation, overhead, profit, and other expenses contemplated for the cash allowances have been included in the Contract Price and not in the allowances, and no demand for additional payment on account of any of the foregoing will be valid.
- C. *Contingency Allowance:*
1. Contractor agrees that a contingency allowance, if any, is for the sole use of Owner to cover unanticipated costs.
- D. Prior to final payment, an appropriate Change Order will be issued as recommended by Engineer to reflect actual amounts due Contractor on account of Work covered by allowances, and the Contract Price shall be correspondingly adjusted.

#### 11.03 *Unit Price Work*

- A. Where the Contract Documents provide that all or part of the Work is to be Unit Price Work, initially the Contract Price will be deemed to include for all Unit Price Work an amount equal to

the sum of the unit price for each separately identified item of Unit Price Work times the estimated quantity of each item as indicated in the Agreement.

- B. The estimated quantities of items of Unit Price Work are not guaranteed and are solely for the purpose of comparison of Bids and determining an initial Contract Price. Determinations of the actual quantities and classifications of Unit Price Work performed by Contractor will be made by Engineer subject to the provisions of Paragraph 9.07.
- C. Each unit price will be deemed to include an amount considered by Contractor to be adequate to cover Contractor's overhead and profit for each separately identified item.
- D. Owner or Contractor may make a Claim for an adjustment in the Contract Price in accordance with Paragraph 10.05 if:
  - 1. the quantity of any item of Unit Price Work performed by Contractor differs materially and significantly from the estimated quantity of such item indicated in the Agreement; and
  - 2. there is no corresponding adjustment with respect to any other item of Work; and
  - 3. Contractor believes that Contractor is entitled to an increase in Contract Price as a result of having incurred additional expense or Owner believes that Owner is entitled to a decrease in Contract Price and the parties are unable to agree as to the amount of any such increase or decrease.

## **ARTICLE 12 – CHANGE OF CONTRACT PRICE; CHANGE OF CONTRACT TIMES**

### *12.01 Change of Contract Price*

- A. The Contract Price may only be changed by a Change Order. Any Claim for an adjustment in the Contract Price shall be based on written notice submitted by the party making the Claim to the Engineer and the other party to the Contract in accordance with the provisions of Paragraph 10.05.
- B. The value of any Work covered by a Change Order or of any Claim for an adjustment in the Contract Price will be determined as follows:
  - 1. where the Work involved is covered by unit prices contained in the Contract Documents, by application of such unit prices to the quantities of the items involved (subject to the provisions of Paragraph 11.03); or
  - 2. where the Work involved is not covered by unit prices contained in the Contract Documents, by a mutually agreed lump sum (which may include an allowance for overhead and profit not necessarily in accordance with Paragraph 12.01.C.2); or
  - 3. where the Work involved is not covered by unit prices contained in the Contract Documents and agreement to a lump sum is not reached under Paragraph 12.01.B.2, on the basis of the Cost of the Work (determined as provided in Paragraph 11.01) plus a Contractor's fee for overhead and profit (determined as provided in Paragraph 12.01.C).

C. *Contractor's Fee*: The Contractor's fee for overhead and profit shall be determined as follows:

1. a mutually acceptable fixed fee; or
2. if a fixed fee is not agreed upon, then a fee based on the following percentages of the various portions of the Cost of the Work:
  - a. for costs incurred under Paragraphs 11.01.A.1 and 11.01.A.2, the Contractor's fee shall be 15 percent;
  - b. for costs incurred under Paragraph 11.01.A.3, the Contractor's fee shall be five percent;
  - c. where one or more tiers of subcontracts are on the basis of Cost of the Work plus a fee and no fixed fee is agreed upon, the intent of Paragraphs 12.01.C.2.a and 12.01.C.2.b is that the Subcontractor who actually performs the Work, at whatever tier, will be paid a fee of 15 percent of the costs incurred by such Subcontractor under Paragraphs 11.01.A.1 and 11.01.A.2 and that any higher tier Subcontractor and Contractor will each be paid a fee of five percent of the amount paid to the next lower tier Subcontractor;
  - d. no fee shall be payable on the basis of costs itemized under Paragraphs 11.01.A.4, 11.01.A.5, and 11.01.B;
  - e. the amount of credit to be allowed by Contractor to Owner for any change which results in a net decrease in cost will be the amount of the actual net decrease in cost plus a deduction in Contractor's fee by an amount equal to five percent of such net decrease; and
  - f. when both additions and credits are involved in any one change, the adjustment in Contractor's fee shall be computed on the basis of the net change in accordance with Paragraphs 12.01.C.2.a through 12.01.C.2.e, inclusive.

#### 12.02 *Change of Contract Times*

- A. The Contract Times may only be changed by a Change Order. Any Claim for an adjustment in the Contract Times shall be based on written notice submitted by the party making the Claim to the Engineer and the other party to the Contract in accordance with the provisions of Paragraph 10.05.
- B. Any adjustment of the Contract Times covered by a Change Order or any Claim for an adjustment in the Contract Times will be determined in accordance with the provisions of this Article 12.

#### 12.03 *Delays*

- A. Where Contractor is prevented from completing any part of the Work within the Contract Times due to delay beyond the control of Contractor, the Contract Times will be extended in an amount equal to the time lost due to such delay if a Claim is made therefore as provided in Paragraph 12.02.A. Delays beyond the control of Contractor shall include, but not be limited to, acts or

neglect by Owner, acts or neglect of utility owners or other contractors performing other work as contemplated by Article 7, fires, floods, epidemics, abnormal weather conditions, or acts of God.

- B. If Owner, Engineer, or other contractors or utility owners performing other work for Owner as contemplated by Article 7, or anyone for whom Owner is responsible, delays, disrupts, or interferes with the performance or progress of the Work, then Contractor shall be entitled to an equitable adjustment in the Contract Price or the Contract Times, or both. Contractor's entitlement to an adjustment of the Contract Times is conditioned on such adjustment being essential to Contractor's ability to complete the Work within the Contract Times.
- C. If Contractor is delayed in the performance or progress of the Work by fire, flood, epidemic, abnormal weather conditions, acts of God, acts or failures to act of utility owners not under the control of Owner, or other causes not the fault of and beyond control of Owner and Contractor, then Contractor shall be entitled to an equitable adjustment in Contract Times, if such adjustment is essential to Contractor's ability to complete the Work within the Contract Times. Such an adjustment shall be Contractor's sole and exclusive remedy for the delays described in this Paragraph 12.03.C.
- D. Owner, Engineer, and their officers, directors, members, partners, employees, agents, consultants, or subcontractors shall not be liable to Contractor for any claims, costs, losses, or damages (including but not limited to all fees and charges of engineers, architects, attorneys, and other professionals and all court or arbitration or other dispute resolution costs) sustained by Contractor on or in connection with any other project or anticipated project.
- E. Contractor shall not be entitled to an adjustment in Contract Price or Contract Times for delays within the control of Contractor. Delays attributable to and within the control of a Subcontractor or Supplier shall be deemed to be delays within the control of Contractor.

## **ARTICLE 13 – TESTS AND INSPECTIONS; CORRECTION, REMOVAL OR ACCEPTANCE OF DEFECTIVE WORK**

### *13.01 Notice of Defects*

- A. Prompt notice of all defective Work of which Owner or Engineer has actual knowledge will be given to Contractor. Defective Work may be rejected, corrected, or accepted as provided in this Article 13.

### *13.02 Access to Work*

- A. Owner, Engineer, their consultants and other representatives and personnel of Owner, independent testing laboratories, and governmental agencies with jurisdictional interests will have access to the Site and the Work at reasonable times for their observation, inspection, and testing. Contractor shall provide them proper and safe conditions for such access and advise them of Contractor's safety procedures and programs so that they may comply therewith as applicable.

### 13.03 *Tests and Inspections*

- A. Contractor shall give Engineer timely notice of readiness of the Work for all required inspections, tests, or approvals and shall cooperate with inspection and testing personnel to facilitate required inspections or tests.
- B. Owner shall employ and pay for the services of an independent testing laboratory to perform all inspections, tests, or approvals required by the Contract Documents except:
  - 1. for inspections, tests, or approvals covered by Paragraphs 13.03.C and 13.03.D below;
  - 2. that costs incurred in connection with tests or inspections conducted pursuant to Paragraph 13.04.B shall be paid as provided in Paragraph 13.04.C; and
  - 3. as otherwise specifically provided in the Contract Documents.
- C. If Laws or Regulations of any public body having jurisdiction require any Work (or part thereof) specifically to be inspected, tested, or approved by an employee or other representative of such public body, Contractor shall assume full responsibility for arranging and obtaining such inspections, tests, or approvals, pay all costs in connection therewith, and furnish Engineer the required certificates of inspection or approval.
- D. Contractor shall be responsible for arranging and obtaining and shall pay all costs in connection with any inspections, tests, or approvals required for Owner's and Engineer's acceptance of materials or equipment to be incorporated in the Work; or acceptance of materials, mix designs, or equipment submitted for approval prior to Contractor's purchase thereof for incorporation in the Work. Such inspections, tests, or approvals shall be performed by organizations acceptable to Owner and Engineer.
- E. If any Work (or the work of others) that is to be inspected, tested, or approved is covered by Contractor without written concurrence of Engineer, Contractor shall, if requested by Engineer, uncover such Work for observation.
- F. Uncovering Work as provided in Paragraph 13.03.E shall be at Contractor's expense unless Contractor has given Engineer timely notice of Contractor's intention to cover the same and Engineer has not acted with reasonable promptness in response to such notice.

### 13.04 *Uncovering Work*

- A. If any Work is covered contrary to the written request of Engineer, it must, if requested by Engineer, be uncovered for Engineer's observation and replaced at Contractor's expense.
- B. If Engineer considers it necessary or advisable that covered Work be observed by Engineer or inspected or tested by others, Contractor, at Engineer's request, shall uncover, expose, or otherwise make available for observation, inspection, or testing as Engineer may require, that portion of the Work in question, furnishing all necessary labor, material, and equipment.

- C. If it is found that the uncovered Work is defective, Contractor shall pay all claims, costs, losses, and damages (including but not limited to all fees and charges of engineers, architects, attorneys, and other professionals and all court or arbitration or other dispute resolution costs) arising out of or relating to such uncovering, exposure, observation, inspection, and testing, and of satisfactory replacement or reconstruction (including but not limited to all costs of repair or replacement of work of others); and Owner shall be entitled to an appropriate decrease in the Contract Price. If the parties are unable to agree as to the amount thereof, Owner may make a Claim therefor as provided in Paragraph 10.05.
- D. If the uncovered Work is not found to be defective, Contractor shall be allowed an increase in the Contract Price or an extension of the Contract Times, or both, directly attributable to such uncovering, exposure, observation, inspection, testing, replacement, and reconstruction. If the parties are unable to agree as to the amount or extent thereof, Contractor may make a Claim therefor as provided in Paragraph 10.05.

#### 13.05 *Owner May Stop the Work*

- A. If the Work is defective, or Contractor fails to supply sufficient skilled workers or suitable materials or equipment, or fails to perform the Work in such a way that the completed Work will conform to the Contract Documents, Owner may order Contractor to stop the Work, or any portion thereof, until the cause for such order has been eliminated; however, this right of Owner to stop the Work shall not give rise to any duty on the part of Owner to exercise this right for the benefit of Contractor, any Subcontractor, any Supplier, any other individual or entity, or any surety for, or employee or agent of any of them.

#### 13.06 *Correction or Removal of Defective Work*

- A. Promptly after receipt of written notice, Contractor shall correct all defective Work, whether or not fabricated, installed, or completed, or, if the Work has been rejected by Engineer, remove it from the Project and replace it with Work that is not defective. Contractor shall pay all claims, costs, losses, and damages (including but not limited to all fees and charges of engineers, architects, attorneys, and other professionals and all court or arbitration or other dispute resolution costs) arising out of or relating to such correction or removal (including but not limited to all costs of repair or replacement of work of others).
- B. When correcting defective Work under the terms of this Paragraph 13.06 or Paragraph 13.07, Contractor shall take no action that would void or otherwise impair Owner's special warranty and guarantee, if any, on said Work.

#### 13.07 *Correction Period*

- A. If within one year after the date of Substantial Completion (or such longer period of time as may be prescribed by the terms of any applicable special guarantee required by the Contract Documents) or by any specific provision of the Contract Documents, any Work is found to be defective, or if the repair of any damages to the land or areas made available for Contractor's use by Owner or permitted by Laws and Regulations as contemplated in Paragraph 6.11.A is found to be defective, Contractor shall promptly, without cost to Owner and in accordance with Owner's written instructions:

1. repair such defective land or areas; or
  2. correct such defective Work; or
  3. if the defective Work has been rejected by Owner, remove it from the Project and replace it with Work that is not defective, and
  4. satisfactorily correct or repair or remove and replace any damage to other Work, to the work of others or other land or areas resulting therefrom.
- B. If Contractor does not promptly comply with the terms of Owner's written instructions, or in an emergency where delay would cause serious risk of loss or damage, Owner may have the defective Work corrected or repaired or may have the rejected Work removed and replaced. All claims, costs, losses, and damages (including but not limited to all fees and charges of engineers, architects, attorneys, and other professionals and all court or arbitration or other dispute resolution costs) arising out of or relating to such correction or repair or such removal and replacement (including but not limited to all costs of repair or replacement of work of others) will be paid by Contractor.
- C. In special circumstances where a particular item of equipment is placed in continuous service before Substantial Completion of all the Work, the correction period for that item may start to run from an earlier date if so provided in the Specifications.
- D. Where defective Work (and damage to other Work resulting therefrom) has been corrected or removed and replaced under this Paragraph 13.07, the correction period hereunder with respect to such Work will be extended for an additional period of one year after such correction or removal and replacement has been satisfactorily completed.
- E. Contractor's obligations under this Paragraph 13.07 are in addition to any other obligation or warranty. The provisions of this Paragraph 13.07 shall not be construed as a substitute for, or a waiver of, the provisions of any applicable statute of limitation or repose.

#### 13.08 *Acceptance of Defective Work*

- A. If, instead of requiring correction or removal and replacement of defective Work, Owner (and, prior to Engineer's recommendation of final payment, Engineer) prefers to accept it, Owner may do so. Contractor shall pay all claims, costs, losses, and damages (including but not limited to all fees and charges of engineers, architects, attorneys, and other professionals and all court or arbitration or other dispute resolution costs) attributable to Owner's evaluation of and determination to accept such defective Work (such costs to be approved by Engineer as to reasonableness) and for the diminished value of the Work to the extent not otherwise paid by Contractor pursuant to this sentence. If any such acceptance occurs prior to Engineer's recommendation of final payment, a Change Order will be issued incorporating the necessary revisions in the Contract Documents with respect to the Work, and Owner shall be entitled to an appropriate decrease in the Contract Price, reflecting the diminished value of Work so accepted. If the parties are unable to agree as to the amount thereof, Owner may make a Claim therefor as provided in Paragraph 10.05. If the acceptance occurs after such recommendation, an appropriate amount will be paid by Contractor to Owner.

### 13.09 *Owner May Correct Defective Work*

- A. If Contractor fails within a reasonable time after written notice from Engineer to correct defective Work, or to remove and replace rejected Work as required by Engineer in accordance with Paragraph 13.06.A, or if Contractor fails to perform the Work in accordance with the Contract Documents, or if Contractor fails to comply with any other provision of the Contract Documents, Owner may, after seven days written notice to Contractor, correct, or remedy any such deficiency.
- B. In exercising the rights and remedies under this Paragraph 13.09, Owner shall proceed expeditiously. In connection with such corrective or remedial action, Owner may exclude Contractor from all or part of the Site, take possession of all or part of the Work and suspend Contractor's services related thereto, take possession of Contractor's tools, appliances, construction equipment and machinery at the Site, and incorporate in the Work all materials and equipment stored at the Site or for which Owner has paid Contractor but which are stored elsewhere. Contractor shall allow Owner, Owner's representatives, agents and employees, Owner's other contractors, and Engineer and Engineer's consultants access to the Site to enable Owner to exercise the rights and remedies under this Paragraph.
- C. All claims, costs, losses, and damages (including but not limited to all fees and charges of engineers, architects, attorneys, and other professionals and all court or arbitration or other dispute resolution costs) incurred or sustained by Owner in exercising the rights and remedies under this Paragraph 13.09 will be charged against Contractor, and a Change Order will be issued incorporating the necessary revisions in the Contract Documents with respect to the Work; and Owner shall be entitled to an appropriate decrease in the Contract Price. If the parties are unable to agree as to the amount of the adjustment, Owner may make a Claim therefor as provided in Paragraph 10.05. Such claims, costs, losses and damages will include but not be limited to all costs of repair, or replacement of work of others destroyed or damaged by correction, removal, or replacement of Contractor's defective Work.
- D. Contractor shall not be allowed an extension of the Contract Times because of any delay in the performance of the Work attributable to the exercise by Owner of Owner's rights and remedies under this Paragraph 13.09.

## **ARTICLE 14 – PAYMENTS TO CONTRACTOR AND COMPLETION**

### 14.01 *Schedule of Values*

- A. The Schedule of Values established as provided in Paragraph 2.07.A will serve as the basis for progress payments and will be incorporated into a form of Application for Payment acceptable to Engineer. Progress payments on account of Unit Price Work will be based on the number of units completed.

### 14.02 *Progress Payments*

#### A. *Applications for Payments:*

- 1. At least 20 days before the date established in the Agreement for each progress payment (but not more often than once a month), Contractor shall submit to Engineer for review an



Application for Payment filled out and signed by Contractor covering the Work completed as of the date of the Application and accompanied by such supporting documentation as is required by the Contract Documents. If payment is requested on the basis of materials and equipment not incorporated in the Work but delivered and suitably stored at the Site or at another location agreed to in writing, the Application for Payment shall also be accompanied by a bill of sale, invoice, or other documentation warranting that Owner has received the materials and equipment free and clear of all Liens and evidence that the materials and equipment are covered by appropriate property insurance or other arrangements to protect Owner's interest therein, all of which must be satisfactory to Owner.

2. Beginning with the second Application for Payment, each Application shall include an affidavit of Contractor stating that all previous progress payments received on account of the Work have been applied on account to discharge Contractor's legitimate obligations associated with prior Applications for Payment.
3. The amount of retainage with respect to progress payments will be as stipulated in the Agreement.

B. *Review of Applications:*

1. Engineer will, within 10 days after receipt of each Application for Payment, either indicate in writing a recommendation of payment and present the Application to Owner or return the Application to Contractor indicating in writing Engineer's reasons for refusing to recommend payment. In the latter case, Contractor may make the necessary corrections and resubmit the Application.
2. Engineer's recommendation of any payment requested in an Application for Payment will constitute a representation by Engineer to Owner, based on Engineer's observations of the executed Work as an experienced and qualified design professional, and on Engineer's review of the Application for Payment and the accompanying data and schedules, that to the best of Engineer's knowledge, information and belief:
  - a. the Work has progressed to the point indicated;
  - b. the quality of the Work is generally in accordance with the Contract Documents (subject to an evaluation of the Work as a functioning whole prior to or upon Substantial Completion, the results of any subsequent tests called for in the Contract Documents, a final determination of quantities and classifications for Unit Price Work under Paragraph 9.07, and any other qualifications stated in the recommendation); and
  - c. the conditions precedent to Contractor's being entitled to such payment appear to have been fulfilled in so far as it is Engineer's responsibility to observe the Work.
3. By recommending any such payment Engineer will not thereby be deemed to have represented that:
  - a. inspections made to check the quality or the quantity of the Work as it has been performed have been exhaustive, extended to every aspect of the Work in progress, or

- involved detailed inspections of the Work beyond the responsibilities specifically assigned to Engineer in the Contract Documents; or
- b. there may not be other matters or issues between the parties that might entitle Contractor to be paid additionally by Owner or entitle Owner to withhold payment to Contractor.
4. Neither Engineer's review of Contractor's Work for the purposes of recommending payments nor Engineer's recommendation of any payment, including final payment, will impose responsibility on Engineer:
    - a. to supervise, direct, or control the Work, or
    - b. for the means, methods, techniques, sequences, or procedures of construction, or the safety precautions and programs incident thereto, or
    - c. for Contractor's failure to comply with Laws and Regulations applicable to Contractor's performance of the Work, or
    - d. to make any examination to ascertain how or for what purposes Contractor has used the moneys paid on account of the Contract Price, or
    - e. to determine that title to any of the Work, materials, or equipment has passed to Owner free and clear of any Liens.
  5. Engineer may refuse to recommend the whole or any part of any payment if, in Engineer's opinion, it would be incorrect to make the representations to Owner stated in Paragraph 14.02.B.2. Engineer may also refuse to recommend any such payment or, because of subsequently discovered evidence or the results of subsequent inspections or tests, revise or revoke any such payment recommendation previously made, to such extent as may be necessary in Engineer's opinion to protect Owner from loss because:
    - a. the Work is defective, or completed Work has been damaged, requiring correction or replacement;
    - b. the Contract Price has been reduced by Change Orders;
    - c. Owner has been required to correct defective Work or complete Work in accordance with Paragraph 13.09; or
    - d. Engineer has actual knowledge of the occurrence of any of the events enumerated in Paragraph 15.02.A.

*C. Payment Becomes Due:*

1. Ten days after presentation of the Application for Payment to Owner with Engineer's recommendation, the amount recommended will (subject to the provisions of Paragraph 14.02.D) become due, and when due will be paid by Owner to Contractor.

D. *Reduction in Payment:*

1. Owner may refuse to make payment of the full amount recommended by Engineer because:
  - a. claims have been made against Owner on account of Contractor's performance or furnishing of the Work;
  - b. Liens have been filed in connection with the Work, except where Contractor has delivered a specific bond satisfactory to Owner to secure the satisfaction and discharge of such Liens;
  - c. there are other items entitling Owner to a set-off against the amount recommended; or
  - d. Owner has actual knowledge of the occurrence of any of the events enumerated in Paragraphs 14.02.B.5.a through 14.02.B.5.c or Paragraph 15.02.A.
2. If Owner refuses to make payment of the full amount recommended by Engineer, Owner will give Contractor immediate written notice (with a copy to Engineer) stating the reasons for such action and promptly pay Contractor any amount remaining after deduction of the amount so withheld. Owner shall promptly pay Contractor the amount so withheld, or any adjustment thereto agreed to by Owner and Contractor, when Contractor remedies the reasons for such action.
3. Upon a subsequent determination that Owner's refusal of payment was not justified, the amount wrongfully withheld shall be treated as an amount due as determined by Paragraph 14.02.C.1 and subject to interest as provided in the Agreement.

14.03 *Contractor's Warranty of Title*

- A. Contractor warrants and guarantees that title to all Work, materials, and equipment covered by any Application for Payment, whether incorporated in the Project or not, will pass to Owner no later than the time of payment free and clear of all Liens.

14.04 *Substantial Completion*

- A. When Contractor considers the entire Work ready for its intended use Contractor shall notify Owner and Engineer in writing that the entire Work is substantially complete (except for items specifically listed by Contractor as incomplete) and request that Engineer issue a certificate of Substantial Completion.
- B. Promptly after Contractor's notification, Owner, Contractor, and Engineer shall make an inspection of the Work to determine the status of completion. If Engineer does not consider the Work substantially complete, Engineer will notify Contractor in writing giving the reasons therefor.
- C. If Engineer considers the Work substantially complete, Engineer will deliver to Owner a tentative certificate of Substantial Completion which shall fix the date of Substantial Completion. There shall be attached to the certificate a tentative list of items to be completed or corrected before

final payment. Owner shall have seven days after receipt of the tentative certificate during which to make written objection to Engineer as to any provisions of the certificate or attached list. If, after considering such objections, Engineer concludes that the Work is not substantially complete, Engineer will, within 14 days after submission of the tentative certificate to Owner, notify Contractor in writing, stating the reasons therefor. If, after consideration of Owner's objections, Engineer considers the Work substantially complete, Engineer will, within said 14 days, execute and deliver to Owner and Contractor a definitive certificate of Substantial Completion (with a revised tentative list of items to be completed or corrected) reflecting such changes from the tentative certificate as Engineer believes justified after consideration of any objections from Owner.

- D. At the time of delivery of the tentative certificate of Substantial Completion, Engineer will deliver to Owner and Contractor a written recommendation as to division of responsibilities pending final payment between Owner and Contractor with respect to security, operation, safety, and protection of the Work, maintenance, heat, utilities, insurance, and warranties and guarantees. Unless Owner and Contractor agree otherwise in writing and so inform Engineer in writing prior to Engineer's issuing the definitive certificate of Substantial Completion, Engineer's aforesaid recommendation will be binding on Owner and Contractor until final payment.
- E. Owner shall have the right to exclude Contractor from the Site after the date of Substantial Completion subject to allowing Contractor reasonable access to remove its property and complete or correct items on the tentative list.

#### 14.05 *Partial Utilization*

- A. Prior to Substantial Completion of all the Work, Owner may use or occupy any substantially completed part of the Work which has specifically been identified in the Contract Documents, or which Owner, Engineer, and Contractor agree constitutes a separately functioning and usable part of the Work that can be used by Owner for its intended purpose without significant interference with Contractor's performance of the remainder of the Work, subject to the following conditions:
  - 1. Owner at any time may request Contractor in writing to permit Owner to use or occupy any such part of the Work which Owner believes to be ready for its intended use and substantially complete. If and when Contractor agrees that such part of the Work is substantially complete, Contractor, Owner, and Engineer will follow the procedures of Paragraph 14.04.A through D for that part of the Work.
  - 2. Contractor at any time may notify Owner and Engineer in writing that Contractor considers any such part of the Work ready for its intended use and substantially complete and request Engineer to issue a certificate of Substantial Completion for that part of the Work.
  - 3. Within a reasonable time after either such request, Owner, Contractor, and Engineer shall make an inspection of that part of the Work to determine its status of completion. If Engineer does not consider that part of the Work to be substantially complete, Engineer will notify Owner and Contractor in writing giving the reasons therefor. If Engineer considers that part of the Work to be substantially complete, the provisions of Paragraph 14.04 will apply with respect to certification of Substantial Completion of that part of the Work and the division of responsibility in respect thereof and access thereto.

4. No use or occupancy or separate operation of part of the Work may occur prior to compliance with the requirements of Paragraph 5.10 regarding property insurance.

#### 14.06 *Final Inspection*

- A. Upon written notice from Contractor that the entire Work or an agreed portion thereof is complete, Engineer will promptly make a final inspection with Owner and Contractor and will notify Contractor in writing of all particulars in which this inspection reveals that the Work is incomplete or defective. Contractor shall immediately take such measures as are necessary to complete such Work or remedy such deficiencies.

#### 14.07 *Final Payment*

##### A. *Application for Payment:*

1. After Contractor has, in the opinion of Engineer, satisfactorily completed all corrections identified during the final inspection and has delivered, in accordance with the Contract Documents, all maintenance and operating instructions, schedules, guarantees, bonds, certificates or other evidence of insurance, certificates of inspection, marked-up record documents (as provided in Paragraph 6.12), and other documents, Contractor may make application for final payment following the procedure for progress payments.
2. The final Application for Payment shall be accompanied (except as previously delivered) by:
  - a. all documentation called for in the Contract Documents, including but not limited to the evidence of insurance required by Paragraph 5.04.B.6;
  - b. consent of the surety, if any, to final payment;
  - c. a list of all Claims against Owner that Contractor believes are unsettled; and
  - d. complete and legally effective releases or waivers (satisfactory to Owner) of all Lien rights arising out of or Liens filed in connection with the Work.
3. In lieu of the releases or waivers of Liens specified in Paragraph 14.07.A.2 and as approved by Owner, Contractor may furnish receipts or releases in full and an affidavit of Contractor that: (i) the releases and receipts include all labor, services, material, and equipment for which a Lien could be filed; and (ii) all payrolls, material and equipment bills, and other indebtedness connected with the Work for which Owner might in any way be responsible, or which might in any way result in liens or other burdens on Owner's property, have been paid or otherwise satisfied. If any Subcontractor or Supplier fails to furnish such a release or receipt in full, Contractor may furnish a bond or other collateral satisfactory to Owner to indemnify Owner against any Lien.

##### B. *Engineer's Review of Application and Acceptance:*

1. If, on the basis of Engineer's observation of the Work during construction and final inspection, and Engineer's review of the final Application for Payment and accompanying

documentation as required by the Contract Documents, Engineer is satisfied that the Work has been completed and Contractor's other obligations under the Contract Documents have been fulfilled, Engineer will, within ten days after receipt of the final Application for Payment, indicate in writing Engineer's recommendation of payment and present the Application for Payment to Owner for payment. At the same time Engineer will also give written notice to Owner and Contractor that the Work is acceptable subject to the provisions of Paragraph 14.09. Otherwise, Engineer will return the Application for Payment to Contractor, indicating in writing the reasons for refusing to recommend final payment, in which case Contractor shall make the necessary corrections and resubmit the Application for Payment.

*C. Payment Becomes Due:*

1. Thirty days after the presentation to Owner of the Application for Payment and accompanying documentation, the amount recommended by Engineer, less any sum Owner is entitled to set off against Engineer's recommendation, including but not limited to liquidated damages, will become due and will be paid by Owner to Contractor.

*14.08 Final Completion Delayed*

- A. If, through no fault of Contractor, final completion of the Work is significantly delayed, and if Engineer so confirms, Owner shall, upon receipt of Contractor's final Application for Payment (for Work fully completed and accepted) and recommendation of Engineer, and without terminating the Contract, make payment of the balance due for that portion of the Work fully completed and accepted. If the remaining balance to be held by Owner for Work not fully completed or corrected is less than the retainage stipulated in the Agreement, and if bonds have been furnished as required in Paragraph 5.01, the written consent of the surety to the payment of the balance due for that portion of the Work fully completed and accepted shall be submitted by Contractor to Engineer with the Application for such payment. Such payment shall be made under the terms and conditions governing final payment, except that it shall not constitute a waiver of Claims.

*14.09 Waiver of Claims*

- A. The making and acceptance of final payment will constitute:
  1. a waiver of all Claims by Owner against Contractor, except Claims arising from unsettled Liens, from defective Work appearing after final inspection pursuant to Paragraph 14.06, from failure to comply with the Contract Documents or the terms of any special guarantees specified therein, or from Contractor's continuing obligations under the Contract Documents; and
  2. a waiver of all Claims by Contractor against Owner other than those previously made in accordance with the requirements herein and expressly acknowledged by Owner in writing as still unsettled.

## ARTICLE 15 – SUSPENSION OF WORK AND TERMINATION

### 15.01 *Owner May Suspend Work*

- A. At any time and without cause, Owner may suspend the Work or any portion thereof for a period of not more than 90 consecutive days by notice in writing to Contractor and Engineer which will fix the date on which Work will be resumed. Contractor shall resume the Work on the date so fixed. Contractor shall be granted an adjustment in the Contract Price or an extension of the Contract Times, or both, directly attributable to any such suspension if Contractor makes a Claim therefor as provided in Paragraph 10.05.

### 15.02 *Owner May Terminate for Cause*

- A. The occurrence of any one or more of the following events will justify termination for cause:
  1. Contractor's persistent failure to perform the Work in accordance with the Contract Documents (including, but not limited to, failure to supply sufficient skilled workers or suitable materials or equipment or failure to adhere to the Progress Schedule established under Paragraph 2.07 as adjusted from time to time pursuant to Paragraph 6.04);
  2. Contractor's disregard of Laws or Regulations of any public body having jurisdiction;
  3. Contractor's repeated disregard of the authority of Engineer; or
  4. Contractor's violation in any substantial way of any provisions of the Contract Documents.
- B. If one or more of the events identified in Paragraph 15.02.A occur, Owner may, after giving Contractor (and surety) seven days written notice of its intent to terminate the services of Contractor:
  1. exclude Contractor from the Site, and take possession of the Work and of all Contractor's tools, appliances, construction equipment, and machinery at the Site, and use the same to the full extent they could be used by Contractor (without liability to Contractor for trespass or conversion);
  2. incorporate in the Work all materials and equipment stored at the Site or for which Owner has paid Contractor but which are stored elsewhere; and
  3. complete the Work as Owner may deem expedient.
- C. If Owner proceeds as provided in Paragraph 15.02.B, Contractor shall not be entitled to receive any further payment until the Work is completed. If the unpaid balance of the Contract Price exceeds all claims, costs, losses, and damages (including but not limited to all fees and charges of engineers, architects, attorneys, and other professionals and all court or arbitration or other dispute resolution costs) sustained by Owner arising out of or relating to completing the Work, such excess will be paid to Contractor. If such claims, costs, losses, and damages exceed such unpaid balance, Contractor shall pay the difference to Owner. Such claims, costs, losses, and damages incurred by Owner will be reviewed by Engineer as to their reasonableness and, when

so approved by Engineer, incorporated in a Change Order. When exercising any rights or remedies under this Paragraph, Owner shall not be required to obtain the lowest price for the Work performed.

- D. Notwithstanding Paragraphs 15.02.B and 15.02.C, Contractor's services will not be terminated if Contractor begins within seven days of receipt of notice of intent to terminate to correct its failure to perform and proceeds diligently to cure such failure within no more than 30 days of receipt of said notice.
- E. Where Contractor's services have been so terminated by Owner, the termination will not affect any rights or remedies of Owner against Contractor then existing or which may thereafter accrue. Any retention or payment of moneys due Contractor by Owner will not release Contractor from liability.
- F. If and to the extent that Contractor has provided a performance bond under the provisions of Paragraph 5.01.A, the termination procedures of that bond shall supersede the provisions of Paragraphs 15.02.B and 15.02.C.

#### 15.03 *Owner May Terminate For Convenience*

- A. Upon seven days written notice to Contractor and Engineer, Owner may, without cause and without prejudice to any other right or remedy of Owner, terminate the Contract. In such case, Contractor shall be paid for (without duplication of any items):
  - 1. completed and acceptable Work executed in accordance with the Contract Documents prior to the effective date of termination, including fair and reasonable sums for overhead and profit on such Work;
  - 2. expenses sustained prior to the effective date of termination in performing services and furnishing labor, materials, or equipment as required by the Contract Documents in connection with uncompleted Work, plus fair and reasonable sums for overhead and profit on such expenses;
  - 3. all claims, costs, losses, and damages (including but not limited to all fees and charges of engineers, architects, attorneys, and other professionals and all court or arbitration or other dispute resolution costs) incurred in settlement of terminated contracts with Subcontractors, Suppliers, and others; and
  - 4. reasonable expenses directly attributable to termination.
- B. Contractor shall not be paid on account of loss of anticipated profits or revenue or other economic loss arising out of or resulting from such termination.

#### 15.04 *Contractor May Stop Work or Terminate*

- A. If, through no act or fault of Contractor, (i) the Work is suspended for more than 90 consecutive days by Owner or under an order of court or other public authority, or (ii) Engineer fails to act on any Application for Payment within 30 days after it is submitted, or (iii) Owner fails for 30 days



to pay Contractor any sum finally determined to be due, then Contractor may, upon seven days written notice to Owner and Engineer, and provided Owner or Engineer do not remedy such suspension or failure within that time, terminate the Contract and recover from Owner payment on the same terms as provided in Paragraph 15.03.

- B. In lieu of terminating the Contract and without prejudice to any other right or remedy, if Engineer has failed to act on an Application for Payment within 30 days after it is submitted, or Owner has failed for 30 days to pay Contractor any sum finally determined to be due, Contractor may, seven days after written notice to Owner and Engineer, stop the Work until payment is made of all such amounts due Contractor, including interest thereon. The provisions of this Paragraph 15.04 are not intended to preclude Contractor from making a Claim under Paragraph 10.05 for an adjustment in Contract Price or Contract Times or otherwise for expenses or damage directly attributable to Contractor's stopping the Work as permitted by this Paragraph.

## **ARTICLE 16 – DISPUTE RESOLUTION**

### *16.01 Methods and Procedures*

- A. Either Owner or Contractor may request mediation of any Claim submitted to Engineer for a decision under Paragraph 10.05 before such decision becomes final and binding. The mediation will be governed by the Construction Industry Mediation Rules of the American Arbitration Association in effect as of the Effective Date of the Agreement. The request for mediation shall be submitted in writing to the American Arbitration Association and the other party to the Contract. Timely submission of the request shall stay the effect of Paragraph 10.05.E.
- B. Owner and Contractor shall participate in the mediation process in good faith. The process shall be concluded within 60 days of filing of the request. The date of termination of the mediation shall be determined by application of the mediation rules referenced above.
- C. If the Claim is not resolved by mediation, Engineer's action under Paragraph 10.05.C or a denial pursuant to Paragraphs 10.05.C.3 or 10.05.D shall become final and binding 30 days after termination of the mediation unless, within that time period, Owner or Contractor:
1. elects in writing to invoke any dispute resolution process provided for in the Supplementary Conditions; or
  2. agrees with the other party to submit the Claim to another dispute resolution process; or
  3. gives written notice to the other party of the intent to submit the Claim to a court of competent jurisdiction.

## **ARTICLE 17 – MISCELLANEOUS**

### *17.01 Giving Notice*

- A. Whenever any provision of the Contract Documents requires the giving of written notice, it will be deemed to have been validly given if:

1. delivered in person to the individual or to a member of the firm or to an officer of the corporation for whom it is intended; or
2. delivered at or sent by registered or certified mail, postage prepaid, to the last business address known to the giver of the notice.

#### 17.02 *Computation of Times*

- A. When any period of time is referred to in the Contract Documents by days, it will be computed to exclude the first and include the last day of such period. If the last day of any such period falls on a Saturday or Sunday or on a day made a legal holiday by the law of the applicable jurisdiction, such day will be omitted from the computation.

#### 17.03 *Cumulative Remedies*

- A. The duties and obligations imposed by these General Conditions and the rights and remedies available hereunder to the parties hereto are in addition to, and are not to be construed in any way as a limitation of, any rights and remedies available to any or all of them which are otherwise imposed or available by Laws or Regulations, by special warranty or guarantee, or by other provisions of the Contract Documents. The provisions of this Paragraph will be as effective as if repeated specifically in the Contract Documents in connection with each particular duty, obligation, right, and remedy to which they apply.

#### 17.04 *Survival of Obligations*

- A. All representations, indemnifications, warranties, and guarantees made in, required by, or given in accordance with the Contract Documents, as well as all continuing obligations indicated in the Contract Documents, will survive final payment, completion, and acceptance of the Work or termination or completion of the Contract or termination of the services of Contractor.

#### 17.05 *Controlling Law*

- A. This Contract is to be governed by the law of the state in which the Project is located.

#### 17.06 *Headings*

- A. Article and paragraph headings are inserted for convenience only and do not constitute parts of these General Conditions.

## SUPPLEMENTARY CONDITIONS

SCOPE. These Supplementary Conditions amend or supplement the Standard General Conditions of the Construction Contract (C-700, 2007 Edition) and other provisions of the Contract Documents as indicated herein. All provisions which are not so amended or supplemented remain in full force and effect.

### SC-1. DEFINITIONS AND TERMINOLOGY.

SC-1.01. DEFINED TERMS. The terms used in these Supplementary Conditions which are defined in the Standard General Conditions of the Construction Contract (C-700, 2007 Edition) have the meanings assigned to them in the General Conditions.

Amend the terms as follows:

3. Application for Payment: Strike out the word "Engineer" and insert the word "Owner" in its place.
9. Change Order: Strike out the words "recommended by Engineer".
12. Contract Documents: In the first sentence, strike out the word "Engineer's" and insert the word "Owner's" in its place.
14. Contract Times: Strike out the words "as evidenced by Engineer's written recommendation of final payment".
15. Contractor: Delete the term "Contractor" and substitute therefore the terms "Contractor or Prime Contractor."
17. Drawings: Add the following sentence to the definition: "Drawings may also be described as Plans."
20. Field Order: Strike out the word "Engineer" and insert the word "Owner" in its place.
22. Hazardous Environmental Conditions: Delete the words " or Radioactive Material" and substitute therefore the words "Radioactive Material or other pollutants or contaminants".
44. Substantial Completion: Strike out the word "Engineer" and insert the word "Owner" in its place. Add the following to the first sentence: "and a Certificate of Substantial Completion has been completed."
51. Work Change Directive: In the first sentence strike out the words "and recommended by Engineer".

Additional terms used in these Supplementary Conditions have the meanings indicated herein, which are applicable to both the singular and plural thereof.

Add the following new definitions to paragraph 1.01:

- “52. Final Completion – The time when all work is complete, including all punch list items, and all documents required for occupancy of the facility are completed and submitted to the OWNER. These documents include, but are not limited to, Certificate of Occupancy, Letters of Approval from various regulatory agencies, inspection certificates, and all other items as required in paragraph 14.07.”
- “53. General Contractor – The person, firm, or corporation with whom OWNER has entered into an Agreement for a complete project, general trades, or complete project less a part of the project.”
- “54. Without exception – The term “without exception”, when used in the Contract Documents following the name of a Supplier or a proprietary item of equipment, product, or material, shall mean that the sources of the product are limited to the listed Suppliers or products and that no like, equivalent, or “or-equal” item and no substitution will be considered.”
- “55. Written Notice – Notice to any party which is in writing and which shall be considered delivered and the service thereof completed once posted by certified or registered mail to the party to whom the notice is sent at its last given address or delivered in person to said party or its authorized representative on the work.”

SC-102. TERMINOLOGY. Add the following paragraphs G, H, and I.

"G. Imperative Mood. These specifications are written to the BIDDER before the award of the Contract and to the CONTRACTOR after award of the Contract. The sentences that direct the CONTRACTOR to perform work are mostly written as commands. For example, a requirement to provide cold-weather protection would be expressed as, 'Provide cold-weather protection for concrete,' rather than 'The Contractor shall provide cold-weather protection for concrete.' In the imperative mood, the subject "the Bidder" or "the Contractor" is understood.

SC-2. PRELIMINARY MATTERS.

SC-2.02. Copies of Documents. Delete the second sentence of paragraph 2.02.A and insert the following new sentence in its place:

“Two (2) sets of contract drawings and specifications will be furnished the Contractor without charge. Additional sets will be furnished upon request at the cost of reproduction. The Contractor shall keep one (1) set of approved plans and specifications on the site of the work. This set shall be kept current by addition of all approved changes, addenda and amendments thereto. One set of as-built plans shall be returned to the Owner after the project is complete.”

The plans and specifications are intended to be complementary; but should any discrepancy appear or any misunderstanding arise as to the import of anything contained in either, the decision of the District shall be final and binding on the Contractor. The District may make any corrections of errors or omissions in the drawings and specifications when such corrections are necessary for the proper fulfillment of their intention as construed by the District. All work or materials shown on the plans and not mentioned in the specifications or any work specified and not shown on the plans, shall be furnished, performed and done by the Contractor as if the same were both mentioned in the specifications and shown on the plans.

All work or materials shown on the plans and not mentioned in the specifications or any work specified and not shown on the plans, shall be furnished, performed and done by the CONTRACTOR as if the same were both mentioned in the specifications and shown on the plans.

Should the Contractor in preparing its bid find anything necessary for the construction of the project that is not mentioned in the specifications or shown on the plans, or any discrepancy, it shall notify the District so that such items may be included. Should the Contractor fail to notify the District of such items, it will be assumed that its bid included everything necessary for the complete construction in the spirit and intent of the designs shown.

In case of discrepancy, figure dimensions shall govern over scale dimensions, large-scale details shall govern over small-scale drawings, plans shall govern over specifications, detailed technical specifications shall govern over general specifications, and the more restrictive specifications shall prevail.”

SC-2.03. Commencement of Contract Times; Notice to Proceed. Delete the paragraph and insert in its place:

"A. The Contract Times will commence to run on the day indicated in the Notice to Proceed. The date for the Contract Times may be extended by mutual agreement between the OWNER and the CONTRACTOR."

SC-2.05. Before Starting Construction. Amend paragraphs 2.05.A and 2.05.B by striking out the word “Engineer” in all locations where it appears in the paragraphs and inserting the word “Owner” in its place.

SC-2.06. Preconstruction Conference. Delete paragraph 2.06.A in its entirety and insert the following new paragraph in its place:

If requested by Owner, within 20 days after the Contract Times start to run, but before any work at the Site is started, a conference attended by Contractor, Owner, and others as appropriate will be held to establish a working understanding among the parties as to the Work and to discuss the schedules referred to in paragraph 2.05.B, procedures for handling Shop Drawings and other submittals, processing Applications for Payment, and maintaining required records.

SC-2.07. Initial Acceptance of Schedules. Amend paragraph 2.07.A, including paragraphs 2.07.A.1, 2.07.A.2, and 2.07.A.3, by striking out the word “Engineer” in all locations where it appears in the paragraph and inserting the word “Owner” in its place.

SC-3. CONTRACT DOCUMENTS: INTENT, AMENDING, REUSE.

SC-3.01. Intent. Amend paragraph 3.01.C by striking out the word “Engineer” and inserting the word “Owner” in its place.

SC-3.03. Reporting and Resolving Discrepancies. Amend paragraph 3.03.A by striking out the word “Engineer” and inserting the word “Owner” in its place.

SC-3.04. Amending and Supplementing Contract Documents. Amend paragraph 3.04.B by striking out the word “Engineer” and inserting the word “Owner” in its place.

SC-4. AVAILABILITY OF LANDS; SUBSURFACE AND PHYSICAL CONDITIONS; REFERENCE POINTS.

SC-4.01.C. Availability of Lands. Add the following language immediately following the words and equipment” in the first sentence:

...and bear all costs associated with.

SC-4.03. Differing Subsurface or Physical Conditions.

Replace paragraph 4.03.A with the following:

"A. Notice: If CONTRACTOR believes that any subsurface or physical condition at or contiguous to the Site that is uncovered or revealed either:

"1. Is of such nature as to require a change in the Contract Documents; or

"2. Differs materially from that shown or indicated in the Contract Documents; or

"3. Is of an unusual nature, and differs materially from conditions ordinarily encountered and generally recognized as inherent on work of the character provided for in the Contract Documents;

"then CONTRACTOR shall, promptly after becoming aware thereof and before further disturbing the subsurface or physical conditions or performing any work in connection therewith (except in an emergency as required by paragraph 6.16.A), notify OWNER and ENGINEER in writing about such condition. CONTRACTOR shall not further disturb such condition or perform any work in connection therewith (except as aforesaid) until receipt of written order to do so."

Delete paragraph 4.03.B in its entirety and insert the following new paragraph in its place:

B. *Owner's Review.* After receipt of written notice as required by paragraph 4.03.A, Owner will promptly review the pertinent condition, determine the necessity if obtaining additional explorations or tests with respect thereto, and advise Contractor in writing of Owner's findings and conclusions.

SC-4.04. Underground Facilities.

Add the following immediately after paragraph 4.04.A.2.

"4.04.A.3 Location of Subsurface Utilities.

"a. The location of subsurface utilities is shown on the plans from information furnished by the utility owners.

"b. The CONTRACTOR shall, no later than 2 working days, excluding Saturdays, Sundays, and legal holidays, prior to construction in the area of the subsurface utility, notify the subsurface utility Owner in writing, by telephone, or in person. The marking

or locating shall be coordinated to stay approximately 2 days ahead of the planned construction.

"c. The CONTRACTOR shall alert immediately the occupants of nearby premises as to any emergency that it may create or discover at or near such premises.

"d. The CONTRACTOR shall have full responsibility for coordination of the work with owners of such underground facilities during construction, for the safety and protection thereof as provided in paragraph 6.13 and repairing any damage thereto resulting from the work, the cost of all of which will be considered as having been included in the Contract Price.

"4.04.A.4 Where existing utilities and structures are indicated as being in the line of the proposed improvement, the CONTRACTOR shall expose them sufficiently in advance of the construction operations to permit adjustments in line or grade, if required, to eliminate interferences.

"4.04.A.5 Existing pipes or conduits crossing a trench, or otherwise exposed, shall be adequately braced and supported to prevent movement during construction.

"4.04.A.6 Broken Utility Services.

"a. Utility services broken or damaged shall be repaired at once to avoid inconvenience to customers and utility owners.

"b. Temporary arrangements, as approved by the ENGINEER, may be used until any damaged items can be permanently repaired.

"c. All items damaged or destroyed by construction and subsequently repaired must be properly maintained by the CONTRACTOR.

"d. CONTRACTOR must work 24 hours a day until service is restored to a damaged utility.

"4.04.A.7 Existing Utility Relocation.

"a. Where it is necessary to relocate an existing utility or structure, the work shall be done in such manner as is necessary to restore it to a condition equal to that of the original utility or structure.

"b. No such relocation shall be done until approval is received from the authority responsible for the utility or structure being changed."

Amend the first sentence of paragraph 4.04.B.1 by striking out the words "and Engineer".

Amend the second sentence of paragraph 4.04.B.2 by striking out the word "Engineer" and inserting the word "Owner" in its place.

Amend the first sentence of paragraph 4.04.B.2 by striking out the word "Engineer" and inserting the word "Owner" in its place.

Add the following new paragraph immediately after paragraph 4.04.B:

Generally, service connections are not indicated on the Drawings. Contractor shall be responsible for discovery of existing underground installations, in advance of excavating or trenching, by contacting all local utilities and by prospecting.

SC-4.06 Hazardous Environmental Conditions at Site.

Delete paragraph 4.06.A. in its entirety and substitute the following paragraph therefore:

A. The following reports and drawings related to Hazardous Environmental Conditions identified at the Site are known to Owner: (None).

Amend paragraph 4.06.B by adding the words "that is created by, or" immediately after the words "a Hazardous Environmental Condition" in the fourth line.

Amend paragraph 4.06.G by deleting all words following the words "Hazardous Environmental Condition" in the seventh line and substituting therefore the following words: "was created by Owner or by anyone for whom Owner is responsible, other than Contractor and all persons, subcontractors and entities for which Contractor is responsible."

SC-5. BONDS AND INSURANCE.

SC-5.01 Performance, Payment, and other Bonds. Add the following language at the end of Paragraph 5.01.C:

Should the CONTRACTOR fail to comply with the requirements of the paragraph, and provide substitute Bond or Bonds within the time limits specified, the OWNER shall suspend all payments to the CONTRACTOR, including those previously authorized but unpaid, until the substitute Bond or Bonds have been submitted.

SC-5.02. Licensed Sureties and Insurers. Add the following new sentence at the end of paragraph 5.02.A:

The surety company shall be rated "A" by AM BEST.

SC-5.03. Certificates of Insurance. Add the following new sentence at the end of paragraph 5.03.A:

Contractor shall deliver to Owner properly completed certificates of insurance prior to the start of any Work at the Site, on the forms included in the Contract Documents.

5.03.G. If a sub-contractor does not take out insurance in his name and his principal contractor wishes to provide insurance protection for such sub-contractor and such sub-contractor's employees, a rider must be attached to the principal contractor's policy, which rider must identify their persons thereby covered, or else the principal contractor must take out appropriate policies in the name of the sub-contractor. The instructions are not retroactive to insurance heretofore approved.



5.03.H. Certificates of insurance coverage shall include a statement of alteration or cancellation provisions of the policy, sufficient to show definitely that such provisions comply with the requirements stated above

SC-5.04. Contractor's Insurance.

Add the following new paragraphs immediately after paragraph 5.04.A.6:

7. Claims arising out of pollution and excluded from the Contractor's general liability and comprehensive automobile liability policies. This insurance shall be coordinated with the Contractor's general liability policy and shall provide bodily injury and property damage coverage similar to the Contractor's general liability policy. Coverage shall include contractual liability.

Add the following new paragraphs immediately after paragraph 5.04.B.6:

7. contain a cross liability or severability of interest clause or endorsement. Insurance covering the specified additional insureds shall be primary insurance, and all other insurance carried by the additional insureds shall be excess insurance;
8. with respect to workers' compensation and employers' liability, comprehensive automobile liability, commercial general liability, and umbrella liability insurance, and all other liability insurance specified herein to be provided by Contractor, Contractor shall require its insurance carriers to waive all rights of subrogation against Owner, Engineer, and their respective officers, directors, partners, employees, and agents.

Add the following new paragraphs immediately after paragraph 5.04.B:

- C. The insurance required by paragraph 5.04 shall include coverage as necessary for the benefits provided under the United States Longshoremen's and Harbor Workers' Act and the Jones Act. This policy shall include an "all states" endorsement.
- D. The limits of liability for the insurance required by paragraph 5.04 of the General Conditions shall provide coverage for not less than the following amounts but shall provide coverage in greater amounts where required by Laws and Regulations. This coverage may be primary or a combination of primary and umbrella excess liability.
  1. Workers' Compensation, and related coverage under paragraphs 5.04.A.1 and 5.04.A.2 of the General Conditions:
    - a. State Statutory
    - b. Applicable Federal (e.g., Longshoreman's) Statutory
    - b. Employer's Liability \$1,000,000 each occurrence
  2. Commercial General Liability under paragraphs 5.04.A.3 through 5.04.A.6 of the General Conditions shall be occurrence type, written in comprehensive form, and shall protect Contractor, Owner, and Engineer as additional insureds, against claims arising from injuries, sickness, disease, or death of any person or damage to property arising out

of performance of the Work. The policy shall also include a per project aggregate limit endorsement, personal injury liability coverage, contractual liability coverage for blasting, explosion, collapse of buildings, and damage to underground property.

- a. General Aggregate \$1,000,000
- b. Products – Completed Operations Aggregate \$1,000,000
- c. Personal and Advertising Injury \$1,000,000
- d. Each Occurrence (Bodily Injury and Property Damage) \$1,000,000
- e. Property Damage liability insurance will provide Explosion, Collapse and Underground coverage's where applicable.

3. Automobile Liability under paragraph 5.04.A.6 of the General Conditions shall be occurrence type, written in comprehensive form, and shall protect Contractor, Owner, and Engineer as additional insureds, against all claims for injuries to members of the public and damage to property of others arising from the use of motor vehicles, either on or off the project site whether they are owned, nonowned, or hired. The liability limit shall be not less than:

- a. Bodily Injury
  - Each Person \$1,000,000
  - Each Accident \$1,000,000
- b. Property Damage
  - Each Accident \$1,000,000
- c. Combined Single Limit \$1,000,000

4. Umbrella Liability Insurance shall protect Contractor, Owner, and Engineer as additional insureds, against claims in excess of the limits provided under workers' compensation and employers' liability, comprehensive automobile liability, and commercial general liability policies. The umbrella policy shall follow the forms of the primary insurance, including the application of the primary limits. The liability limits shall be not less than:

- Bodily injury and Property damage \$4,000,000 combined single limit for each occurrence
- \$4,000,000 general aggregate

SC-5.05. Owner's Liability Insurance. Delete paragraph 5.05 in its entirety and insert the following new paragraph in its place:

5.05. *Owner's Liability Insurance*. This insurance shall be obtained by Contractor and issued in the name of Owner, and shall protect and defend Owner against claims arising as a result of the operations of Contractor or Contractor's Subcontractors. The liability limits shall be not less than:

a.	Bodily Injury	
	Each Occurrence	\$1,000,000
	General Aggregate	\$1,000,000
b.	Property Damage	
	Each Occurrence	\$1,000,000
	General Aggregate	\$1,000,000

SC-5.06. Property Insurance. Delete paragraph 5.06 in its entirety and insert the following new paragraphs in their place:

5.06. *Property Insurance*

- A. Contractor shall purchase and maintain property insurance coverage upon the Work at the Site in the amount of the full replacement cost thereof. This insurance shall:
1. include the interests of Owner, Contractor, Subcontractors, Engineer, Engineer's Consultants, and any other individuals or entities identified in the Supplementary Conditions, and the officers, directors, partners, employees, agents, and other consultants and subcontractors of each and any of them, each of whom is deemed to have an insurable interest and shall be listed as an additional insured;
  2. be written on a Builder's Risk "all-risk" or open peril or special causes of loss policy form that shall at least include insurance for physical loss or damage to the Work, temporary buildings, false work, and materials and equipment, and shall insure against at least the following perils or causes of loss: fire, lightning, extended coverage, theft, vandalism and malicious mischief, earthquake, collapse, debris removal, demolition occasioned by enforcement of Laws and Regulations, water damage, flood, damage caused by frost and freezing, and such other perils or causes of loss as may be specifically required by the Supplementary Conditions;
  3. cover materials and equipment stored at the Site or at another location that was agreed to in writing by Owner prior to being incorporated in the Work, provided that such materials and equipment have been included in an Application for Payment accepted by Owner;
  4. include expenses incurred in the repair or replacement of any insured property (including, but not limited to, fees and charges of engineers and architects);
  5. allow for partial utilization of the Work by Owner;
  6. include testing and startup; and

7. be maintained in effect until final payment is made unless otherwise agreed to in writing by Owner, Contractor, and Engineer, with 30 days' written notice to each other additional insured to whom a certificate of insurance has been issued.

B. Contractor shall be responsible for any deductible or self-insured retention.

C. All the policies of insurance (and the certificates or other evidence thereof) required to be purchased and maintained in accordance with paragraph 5.06 shall contain a provision or endorsement that the coverage afforded will not be canceled or materially changed or renewal refused until at least 30 days prior written notice has been given to Owner and Contractor and to each other additional insured to whom a certificate of insurance has been issued and will contain waiver provisions in accordance with paragraph 5.07.

D. If Owner requests in writing that other special insurance be included in the property insurance policies provided under paragraph 5.06, Contractor shall, if possible, include such insurance, and the cost thereof will be charged to Owner by appropriate Change Order or Written Amendment. Prior to commencement of the Work at the Site, Contractor shall in writing advise Owner whether or not Contractor has procured such other special insurance.

#### SC-6. CONTRACTOR'S RESPONSIBILITIES.

SC-6.02. Labor; Working Hours. Add the following new paragraphs immediately after paragraph 6.02.B:

C. No Work shall be done between 6:00 p.m. and 7:00 a.m. without permission of Owner. However, emergency work may be done without prior permission.

D. Night Work may be undertaken as a regular procedure with the permission of Owner; such permission, however, may be revoked at any time by Owner if Contractor fails to maintain adequate equipment and supervision for the proper prosecution and control of the Work at night.

SC-6.03. Services, Materials, and Equipment. Amend the second sentence of paragraph 6.03.B by striking out the word "Engineer" and inserting the word "Owner" in its place.

SC-6.04. Progress Schedule. Amend the first sentence of paragraph 6.04.A.1 by striking out the word "Engineer" and inserting the word "Owner" in its place.

SC-6.05. Substitutes and "Or-Equals". Amend paragraph 6.05, including paragraphs 6.05.A, 6.05.A.1, 6.05.A.1.a, 6.05.A.1.b, 6.05.A.2, 6.05.A.2.a, 6.05.A.2.b, 6.05.A.2.c, 6.05.A.2.d, 6.05.B, 6.05.C, 6.05.D, and 6.05.E by striking out the words "Engineer" and "Engineer's" in all locations where they appear in the paragraph and inserting the words "Owner" and "Owner's", respectively, in their place.

Add the following new paragraph after paragraph 6.05.A.2.d:

e. "If a proposed substitute item is accepted, all incidental costs associated with the use of the substitute including, but not limited to, redesign, claims of other Contractors, changes to electrical supply equipment, additional equipment or material required for the installation, etc., shall be at the expense of the Contractor proposing the substitute unless otherwise agreed to by the Owner."

SC-6.06.B In addition to Paragraph 6.06.B, add the following:

“The apparent Successful Bidder and any other Bidder so requested, shall within five days after the day of the Bid opening provide a list of Subcontractors and Suppliers with an experience statement indicating pertinent information as to similar projects and other evidence of qualification for each Subcontractor for Supplier proposed for those portions of the Work for which the total dollar amount exceeds \$20,000. Reasonable objection against Subcontractors or Suppliers may include but not be limited to the following reasons: fraud, collusion, defaulting on previous work, poor credit rating, lack of financial ability, safety violations, unpaid taxes, etc.”

SC-6.08. Permits. Add the following new paragraph immediately after paragraph 6.08.A:

B. Owner will obtain and pay for the following permits: Road & Highway Encroachment Permits, Kentucky Division of Water, and Stream Crossing Permits.

SC-6.09. Laws and Regulations. Add the following new paragraph immediately after paragraph 6.09.C:

D. Employment requirements shall be as specified herein and in the attachments at the end of the Supplementary Conditions.

SC-6.10. Taxes. Add the following new paragraph immediately after Paragraph 6.10.A of the General Conditions:

B. Portions of this project may be exempt from taxes. It is the Contractor's responsibility to determine any applicable exemptions.

SC-6.12. Record Documents. Amend the second sentence of paragraph 6.12.A by striking out the word “Engineer” and inserting the word “Owner” in its place.

Amend the third sentence of paragraph 6.12.A by striking out the words “Engineer for”.

SC-6.15 Add a new paragraph immediately after paragraph 6.15.A, which is to read as follows:

6.15.B. CONTRACTOR shall be responsible for coordinating any exchange of material safety data sheets or other hazard communication information required to be made available to or exchanged between or among employers at the Site in accordance with all Laws and Regulations. CONTRACTOR shall provide a centralized location for the maintenance of the material safety data sheets or other hazard communication information required to be made available by any employer on the Site. Location of the material safety data sheets or other hazard communication information shall be readily accessible to the employees of any employer on the Site.

SC-6.16. Emergencies. Amend paragraph 6.16 by striking out the word “Engineer” in all locations where it appears in the paragraph and inserting the word “Owner” in its place.

Add the following new paragraph immediately after paragraph 6.16.A:

B. The Contractor understands and agrees that during the performance of the Contract, it shall maintain a presence within such proximity of the Work Site which will allow it to respond to an emergency at the Work Site within one hour of receiving notice of an emergency, including emergencies occurring during non-working hours. The Contractor shall provide a list of emergency

phone numbers for such purposes. If the Contractor does not have such a presence, it may satisfy this requirement by sub-contracting with a sub-contractor that does have such a presence, provided that any such sub-contractor must be approved by the Owner, in its sole discretion, prior to the project pre-construction meeting.

SC-6.17. Shop Drawings and Samples. Amend paragraph 6.17, including paragraphs 6.17.A, 6.17.B, 6.17.C, 6.17.D, 6.17.D.1, 6.17.D.1.a, 6.17.D.1.b, 6.17.D.1.c, 6.17.D.1.d, 6.17.D.2, 6.17.D.3, 6.17.E.1, 6.17.E.2, 6.17.E.3, and 6.17.F.1 by striking out the words “Engineer” and “Engineer’s” in all locations where they appear in the paragraph and inserting the words “Owner” and “Owner’s”, respectively, in their place.

SC-6.19. Contractor’s General Warranty and Guarantee. Amend paragraph 6.19.C.1 by adding the words “or Owner” at the end of the paragraph.

Amend paragraph 6.19.C.2 by striking out the words “recommendation by Engineer or”.

Amend paragraph 6.19.C.3 by striking out the words “by Engineer”.

Amend paragraph 6.19.C.6 by striking out the word “Engineer” and inserting the word “Owner” in its place.

Delete paragraph 6.19.C.7 and substitute the following new paragraph therefore:

7. any correction of defective Work by Owner; or

Add the following new paragraph immediately after paragraph 6.19.C.7:

8. any expiration of a correction period.

#### SC-7. OTHER WORK.

SC-7.01. Related Work at Site. Amend paragraphs 7.01.B and 7.01.C by striking out the word “Engineer” in all locations where it appears in the paragraphs and inserting the word “Owner” in its place.

#### SC-8. OWNER’S RESPONSIBILITIES.

SC-8.01. Communications to Contractor. Amend paragraph A by striking out “through Engineer”.

SC-8.02. Replacement of Engineer. Delete paragraph 8.02 in its entirety.

#### SC-9. ENGINEER’S STATUS DURING CONSTRUCTION.

SC-9.01. Owner’s Representative. Delete paragraph 9.01 in its entirety.

SC-9.02. Visits to Site. Amend paragraphs 9.02.A and 9.02.B by striking out the words “Engineer” and “Engineer’s” in all locations where they appear in the paragraph and inserting the words “Owner” and “Owners”, respectively, in their place. Add following new paragraph:

B. Engineer may make visits to the Site as Owner deems necessary in order to observe as an experienced and qualified design professional the progress that has been made and the quality of the various aspects of Contractor's executed Work. Based on information obtained during such visits and observations, Engineer, at the request and benefit of Owner, may determine, in general, if the Work is proceeding in accordance with the Contract Documents. Engineer will not be required to make exhaustive or continuous inspections on the Site to check the quality or quantity of the Work. Engineer's efforts will be directed toward providing for Owner a greater degree of confidence that the completed Work will conform generally to the Contract Documents. On the basis of such visits and observations, Engineer will advise Owner of the progress of the Work and will endeavor to guard Owner against defective Work.

SC-9.04. Clarifications and Interpretations. Amend paragraph 9.04 by striking out the word "Engineer" in all locations where it appears in the paragraph and inserting the word "Owner" in its place.

SC-9.05. Authorizing Variations in Work. Amend paragraph 9.05 by striking out the word "Engineer" in all locations where it appears in the paragraph and inserting the word "Owner" in its place.

SC-9.06. Rejecting Defective Work. Amend paragraph 9.06 by striking out the word "Engineer" in all locations where it appears in the paragraph and inserting the word "Owner" in its place.

SC-9.07. Shop Drawings, Change Orders and Payments. Delete paragraph 9.07 in its entirety.

SC-9.08. Determinations for Unit Price Work. Delete paragraph 9.08 in its entirety.

SC-9.09. Decisions on Requirements of Contract Documents and Acceptability of Work. Delete paragraph 9.09 in its entirety.

SC-9.10. Limitations on Engineer's Authority and Responsibilities. Delete paragraph 9.10.D in its entirety.

#### SC-10. CHANGES IN THE WORK.

SC-10.03. Execution of Change Orders. Amend paragraph 10.03.A by striking out the words "recommended by Engineer".

Amend paragraph 10.03.A.3 by striking out the word "Engineer" and inserting the word "Owner" in its place.

SC-10.05. Claims and Disputes. Amend paragraph 10.05 by deleting paragraphs 10.05.A, 10.05.B, 10.05.B.1, 10.05.B.2, and 10.05.C in their entirety and inserting the following new paragraphs in their place:

A. *Notice.* Written notice stating the general nature of each Claim, dispute, or other matter shall be delivered by Contractor to Owner no later than 30 days after the start of the event giving rise thereto. Notice of the amount of extent of the Claim, dispute, or other matter with supporting data shall be delivered to Owner within 60 days after the start of such event, unless the Owner allows, in writing, additional time for Contractor to submit additional or more accurate data in support of such Claim, dispute, or other matter. A Claim for an adjustment in Contract Price shall be prepared in accordance with the provisions of paragraph 12.01.B. A Claim for an adjustment in Contract Time shall be prepared in accordance with the provisions of paragraph 12.02.B. Each Claim shall be

accompanied by Contractor's written statement that the adjustment claimed is the entire adjustment to which Contractor believes it is entitled as a result of said event.

B. *Owner's Decisions.* Owner will render a formal decision in writing within 30 days after receipt of the last submittal of Contractor.

C. If Owner does not render a formal decision in writing within the time stated in paragraph 10.05.B, a decision denying the Claim in its entirety shall be deemed to have been issued 31 days after receipt of the last submittal of Contractor, unless Owner notifies Contractor in writing that a formal decision is pending and will be rendered within a specified number of days or by a specified date.

SC-11. COST OF THE WORK; CASH ALLOWANCES; UNIT PRICE WORK.

SC-11.01. Cost of the Work. Amend the second sentence of paragraph 11.01.A.3 by striking out the words "with the advice of Engineer".

Amend paragraph 11.01.D by striking out the word "Engineer" and inserting the word "Owner" in its place.

SC-11.02. Cash Allowances. Amend paragraph 11.02.A by striking out the words "and Engineer".

Amend paragraph 11.02.B by striking out the words "as recommended by Engineer".

SC-11.9. Unit Price Work. Add the following new paragraph immediately after paragraph 11.9.3.3

11.9.4. The unit price of an item of Unit Price Work shall be subject to reevaluation and adjustment by Change Order if the variation in the actual quantity of an item of Unit Price Work performed by Contractor differs by more than 25 percent from the estimated quantity of that item indicated in the Bid.

SC-12. CHANGE OF CONTRACT PRICE; CHANGE OF CONTRACT TIMES.

SC-12.01. Change of Contract Price. Delete paragraph 12.01.A in its entirety and insert the following new paragraph in its place:

A. The Contract Price may only be changed by a Change Order. Any Claim for an adjustment in the Contract Price shall be based on written notice submitted by Contractor to Owner in accordance with the provisions of paragraph 10.05.

SC-12.02. Change of Contract Times. Delete paragraph 12.02.A in its entirety and insert the following new paragraph in its place:

A. The Contract Times (or Milestones) may only be changed by a Change Order. Any Claim for an adjustment in the Contract Times (or Milestones) shall be based on written notice submitted by Contractor to owner in accordance with the provisions of paragraph 10.05.

SC-12.03. Delays. Insert the following new sentence following the first sentence of paragraph 12.03.A:

This extension shall be Contractor's sole and exclusive remedy for such delay.



Insert the following new paragraph 12.03.F immediately after paragraph 12.03.E:

F. In no event shall Owner be liable to Contractor, any Subcontractor, any Supplier, or any other person or organization, or to any surety for or employee or agent of any of them, for damages (including acceleration costs) arising out of or resulting from any delay.

SC-13. TESTS AND INSPECTIONS; CORRECTION, REMOVAL, OR ACCEPTANCE OF DEFECTIVE WORK.

SC-13.02. Access to Work. Add the following new paragraph immediately after paragraph 13.02.A:

B. Authorized representatives of the U.S. Environmental Protection Agency and the Kentucky Division of Water shall have access to the Work whenever it is in preparation or progress. Contractor shall provide proper facilities for such access and inspection.

SC-13.03. Tests and Inspections. Amend paragraph 13.03.A by striking out the word "Engineer" and inserting the word "Owner" in its place.

Amend paragraph 13.03.C by striking out the word "Engineer" and inserting the word "Owner" in its place.

Amend paragraph 13.03.E by striking out the word "Engineer" in both locations where it appears in the paragraph and inserting the word "Owner" in its place.

Amend paragraph 13.03.F by striking out the word "Engineer" in both locations where it appears in the paragraph and inserting the word "Owner" in its place.

SC-13.04. Uncovering Work. Amend paragraph 13.04.A by striking out the words "Engineer" and "Engineer's" in all locations where they appear in the paragraph and inserting the words "Owner" and "Owner's", respectively, in their place.

Delete paragraph 13.04.B in its entirety and insert the following new paragraph in its place:

B. If Owner considers it necessary or advisable that covered Work be observed by Engineer or Owner's representatives, or inspected or tested by others, Contractor, at Owner's request, shall uncover, expose, or otherwise make available for observation, inspection, or testing as Owner may require, that portion of the Work in question, furnishing all necessary labor, material and equipment. If it is found that such Work is defective, Contractor shall pay all Claims, costs, losses, and damages (including but not limited to all fees and charges of engineers, architects, attorneys, and other professionals and all court or arbitration or other dispute resolution costs) arising out of or relating to such uncovering, exposure, observation, inspection, and testing, and of satisfactory replacement or reconstruction (including but not limited to all costs of repair or replacement of work of others); and Owner shall be entitled to an appropriate decrease in the Contract Price. If, however, such Work is not found to be defective, Contractor shall be allowed an increase in the Contract Price or an extension of the Contract Times (or Milestones), or both, directly attributable to such uncovering, exposure, observation, inspection, testing, replacement, and reconstruction. If the parties are unable to agree as to the amount or extent thereof, Contractor may make a Claim therefor as provided in paragraph 10.05.

SC-13.06. Correction or Removal of Defective Work. Amend paragraph 13.06.A by inserting the words “or Owner” following the word “Engineer”.

SC-13.07. Correction Period. Add the following new paragraph after paragraph 13.07.E:

F. Nothing in Article 13 concerning the correction period shall establish a period of limitation with respect to any other obligation which Contractor has under the Contract Documents. The establishment of time periods relates only to the specific obligations of Contractor to correct the Work, and has no relationship to the time within which Contractor's obligations under the Contract Documents may be sought to be enforced, nor to the time within which proceedings may be commenced to establish Contractor's liability with respect to Contractor's obligations other than to specifically correct the Work.

All machinery, piping, materials, equipment, fittings, and restoration of every kind furnished under this Contract by the Contractor shall be free from defects of manufacture and/or workmanship. The Contractor agrees to replace materials, workmanship, and restoration, which includes all roadway pavement work, shoulder and ditch restoration and repairs, which are found to be defective within twenty four (24) months after issuance of the “Certificate of Substantial Completion”. In cases where such defects shall be caused by forces beyond the Contractor’s control, as judged by the Owner, the replacements will not have to be made by the Contractor.

SC-13.08. Acceptance of Defective Work. Delete paragraph 13.08.A in its entirety and insert the following new paragraph in its place:

A. If, instead of requiring correction or removal and replacement of defective Work, Owner, prior to making final payment, prefers to accept it, Owner may do so. Contractor shall pay all Claims, costs, losses, and damages (including but not limited to all fees and charges of engineers, architects, attorneys, and other professionals and all court or arbitration or other dispute resolution costs) attributable to Owner’s evaluation of and determination to accept such defective Work and the diminished value of the Work to the extent not otherwise paid by Contractor pursuant to this sentence. If any such acceptance occurs prior to Owner making final payment, a Change Order will be issued incorporating the necessary revisions in the Contract Documents with respect to the Work, and Owner shall be entitled to an appropriate decrease in the Contract Price, reflecting the diminished value of the Work so accepted. If the acceptance occurs after making final payment, an appropriate amount will be paid by Contractor to Owner.

SC-13.09. Owner May Correct Defective Work. Amend paragraph 13.09.A by striking out the word “Engineer” in all locations where it appears in the paragraph and inserting the word “Owner” in its place.

#### SC-14. PAYMENTS TO CONTRACTOR AND COMPLETION.

SC-14.01. Schedule of Values. Amend paragraph 14.01.A by striking out the word “Engineer” and inserting the word “Owner” in its place.

SC-14.02. Progress Payments. Amend paragraph 14.02.A by striking out the word “Engineer” and inserting the word “Owner” in its place.

Add the following new paragraphs immediately after paragraph 14.02.A.3:

4. Contractor's Applications for Payment shall be accompanied by the documentation specified herein.

5. Payments for stored materials and equipment shall be based only upon the actual cost to Contractor of the materials and equipment and shall not include any overhead or profit to Contractor. Partial payments will not be made for undelivered materials or equipment.

6. During the progress of the Work, each Application for Payment shall be accompanied by Contractor's updated schedule of operations, or progress report, with such shop drawings schedules, procurement schedules, value of material on hand included in application, and other data specified in Contract Documents or reasonably required by Owner.

Delete paragraphs 14.02.B and 14.02.C in their entirety and insert the following new paragraphs in their place:

*B. Review of Applications*

1. Owner will, within 10 days after receipt of each Application for Payment, either begin processing the Application for Payment to Contractor or return the Application to Contractor indicating in writing Owner's reasons for refusing payment. In the latter case, Contractor may make the necessary corrections and resubmit the Application.

2. Owner's review of Contractor's Application for Payment will consider whether the following have been achieved:

- a. the Work has progressed to the point indicated;
- b. the quality of the Work is generally in accordance with the Contract Documents (subject to an evaluation of the Work as a functioning whole prior to or upon Substantial Completion, to the results of any subsequent tests called for in the Contract Documents, to a final determination of quantities and classifications for Unit Price Work under paragraph 9.08, and to any other qualifications as reasonably applied by Owner); and
- c. the conditions precedent to Contractor's being entitled to such payment appear to have been fulfilled in so far as Owner or Engineer has observed the Work.

3. By processing and making such payment Owner will not thereby be deemed to have represented that:

- a. inspections made to check the quality or the quantity of the Work as it has been performed have been exhaustive, extended to every aspect of the Work in progress, or involved detailed inspections of the Work; or
- b. that there may not be other matters or issues between the parties that might entitle Contractor to be paid additionally by Owner or entitle Owner to withhold payment to Contractor.

4. Neither Owner's review of Contractor's Work for the purposes of processing payments nor Owner's making any such payments, including final payment, will impose responsibility on Owner:

- a. to supervise, direct, or control the Work, or
- b. for the means, methods, techniques, sequences, or procedures of construction, or the safety precautions and programs incident thereto, or
- c. for Contractor's performance of the Work.
- d. to make any examination to ascertain how or for what purposes Contractor has used the moneys paid on account of the Contract Price, or
- e. to determine that title to any of the Work, materials, or equipment has passed to Owner free and clear of any Liens.

5. Owner may refuse to process or make the whole or any part of any payment if, in Owner's opinion, the criteria referred to in paragraph 14.02.B.2 has not been met. Owner may also refuse to process or make any such payment or, because of subsequently discovered evidence or the results of subsequent inspections or tests, revise or revoke any such payment previously made, to such extent as may be necessary in Owner's opinion to protect Owner from loss because:

- a. the Work is defective, or completed Work has been damaged, requiring correction or replacement;
- b. the Contract Price has been reduced by Written Amendment or Change Orders;
- c. Owner has been required to correct defective Work or complete Work in accordance with paragraph 13.09; or
- d. Owner has actual knowledge of the occurrence of any of the events enumerated in paragraph 15.02.A.

Delete paragraphs 14.02.C in its entirety and insert the following new paragraphs in its place:

*C. Payment Becomes Due*

1. Twenty-five days after presentation of the Application for Payment to Owner, the amount recommended will (subject to the provisions of paragraph 14.02.D) become due, and when due will be paid by Owner to Contractor.

Amend paragraph 14.02.D.1 by striking out the words "recommended by Engineer" and inserting the words "requested by Contractor" in their place.

Delete paragraph 14.02.D.2 in its entirety and insert the following new paragraph in its place:

2. If Owner refuses to make payment of the full amount requested by Contractor, Owner must give Contractor immediate written notice stating the reasons for such action and promptly pay Contractor any amount remaining after deduction of the amount so withheld. Owner shall promptly pay Contractor the amount so withheld, or any adjustment thereto agreed to by Owner and Contractor, when Contractor corrects to Owner's satisfaction the reasons for such action.

SC-14.04. Substantial Completion. Delete paragraph 14.04.A in its entirety and insert the following new paragraph in its place:

A. When Contractor considers the entire Work ready for its intended use Contractor shall notify Owner in writing that the entire Work is substantially complete (except for items specifically listed by Contractor as incomplete) and request that Owner issue a certificate of Substantial Completion.

B. Promptly thereafter, Owner and Contractor shall make an inspection of the Work to determine the status of completion. If Owner does not consider the Work substantially complete, Owner will notify Contractor in writing giving the reasons therefor.

C. If Owner considers the Work substantially complete, Owner will within 14 days after the inspection of the Work execute and deliver to Contractor a statement of Substantial Completion.

D. At the time of delivery of the certificate of Substantial Completion, Owner will deliver to Contractor a statement as to division of responsibilities pending final payment between Owner and Contractor with respect to security, operation, safety, and protection of the Work, maintenance, heat, utilities, insurance, and warranties and guarantees. Unless Owner and Contractor subsequently agree otherwise in writing, Owner's aforesaid statement will be binding on Owner and Contractor until final payment.

Add the following new paragraphs following paragraph 14.04.A:

To be considered substantially complete, the following portions of the Work must be operational and ready for Owner's continuous use as intended: Water main is tested and placed into service, services are connected to the new main if applicable to the project, and rough restoration is complete.

Portions of the Work not essential to operation, which can be completed without interruption of the Owner's operation, may be completed after the Work is accepted as substantially complete, and may include the following items: final restoration such as seeding and sodding.

SC-14.05. Partial Utilization. Amend paragraph 14.05.A by striking out the word "Engineer".

SC-14.06. Final Inspection. Delete paragraph 14.06.A in its entirety and insert the following new paragraph in its place:

A. Upon written notice from Contractor that the entire Work or an agreed portion thereof is complete, Owner and Contractor shall promptly make a final inspection of the Work. Owner will notify Contractor in writing of all particulars in which this inspection reveals that the Work is incomplete or defective. Contractor shall immediately take such measures as are necessary to complete such Work or remedy such deficiencies.

SC-14.07. Final Application for Payment. Amend paragraph 14.07.A.1 by striking out the word "Engineer" and inserting the word "Owner" in its place.

Add the following new sentence immediately after the last sentence of paragraph 14.07.A.2.b.:

Consent of the surety, signed by an agent, must be accompanied by a certified copy of such agent's authority to act for the surety. The Contractor shall be responsible for providing all of the documents identified in this paragraph.

Delete paragraph 14.07.B in its entirety and insert the following new paragraph in its place:

*B. Review of Application and Acceptance.* If, on the basis of Owner's observation of the Work during construction and final inspection, and Owner's review of the final Application for Payment and accompanying documentation as required by the Contract Documents, Owner is satisfied that the Work has been completed and Contractor's other obligations under the Contract Documents have been fulfilled, Owner will process the final Application for Payment. Otherwise, Owner will return the Application for Payment to Contractor, indicating in writing the reasons for refusing to process final payment, in which case Contractor shall make the necessary corrections and resubmit the Application for Payment.

Amend paragraph 14.07.C by striking out the words "recommended by Engineer" and inserting the words "requested by Contractor" in their place.

SC-14.08. Final Completion Delayed. Delete paragraph 14.08.A in its entirety and insert the following new paragraph in its place:

A. If, through no fault of Contractor, final completion of the Work is significantly delayed, Owner shall, upon receipt of Contractor's final Application for Payment, and without terminating the Agreement, make payment of the balance due for that portion of the Work fully completed and accepted. If the remaining balance to be held by Owner for Work not fully completed or corrected is less than the retainage stipulated in the Agreement, and if Bonds have been furnished as required in paragraph 5.01, the written consent of the surety to the payment of the balance due for that portion of the Work fully completed and accepted shall be submitted by Contractor to Owner with the Application for such payment. Such payment shall be made under the terms and conditions governing final payment, except that it shall not constitute a waiver of Claims.

#### SC-15. SUSPENSION OF WORK AND TERMINATION.

SC-15.01. Owner May Suspend Work. Amend paragraph 15.01.A by striking out the words "and Engineer".

SC-15.02. Owner May Terminate for Cause. Amend paragraph 15.02.B by deleting the fourth sentence of the paragraph, in its entirety, which begins: "Such Claims, costs, losses, and damages incurred...".

SC-15.04. Contractor May Stop Work or Terminate. Delete paragraph 15.04.A and 15.04.B in their entirety and insert the following new paragraph in its place:

A. If, through no act or fault of Contractor, the Work is suspended for more than 90 consecutive days by Owner or under an order of court or other public authority, or Owner fails to act on any Application for Payment within 30 days after it is submitted, or Owner fails for 30 days to pay Contractor any sum finally determined to be due, then Contractor may, upon seven days written notice to Owner, and provided Owner does not remedy such suspension or failure within that time, terminate the Contract and recover from Owner payment on the same terms as provided in paragraph 15.03.

B. In lieu of terminating the Contract and without prejudice to any other right or remedy, if Owner has failed for 30 days to pay Contractor any sum finally determined to be due, Contractor may, seven days after written notice to Owner, stop the Work until payment is made of all such amounts dues Contractor, including interest thereon. The provisions of this paragraph 15.04 are not intended to preclude Contractor from making a Claim under paragraph 10.05 for an adjustment in Contract Price or Contract Times or otherwise for expenses or damage directly attributable to Contractor's stopping the Work as permitted by this Paragraph.

SC-16. DISPUTE RESOLUTION.

Delete Article 16 in its entirety and insert the following new article in its place:

ARTICLE 16 - DISPUTES.

Arbitration will not be acceptable as a means for settling claims, disputes, and other matters.

SC-17. MISCELLANEOUS.

SC-17.04. Survival of Obligations. Add the following new paragraph immediately after paragraph 17.04.A:

B. Contractor shall obtain from all Suppliers and manufacturers any and all warranties and guarantees of such Suppliers and manufacturers, whether or not specifically required by the Specifications, and shall assign such warranties and guarantees to Owner. With respect thereto, Contractor shall render reasonable assistance to Owner when requested, in order to enable Owner to enforce such warranties and guarantees. The assignment of any warranties or guarantees shall not affect the Correction Period or any other provisions of these Contract Documents.

++END OF SECTION++

(This page left blank intentionally)



## SECTION 00835

### EMPLOYMENT REQUIREMENTS AND WAGE RATES

R-1. GENERAL. This Contract shall be based upon payment by the Contractor and his Subcontractors of wage rates not less than the prevailing hourly wage rate for each craft or type of workman engaged on the Work as determined by the Department of Labor of the Commonwealth of Kentucky.

The Contractor shall comply with the prevailing wage law of Kentucky, Kentucky Revised Statutes 337.510 to 337.550, including latest amendments thereto.

The Contractor and each Subcontractor shall keep accurate records indicating the hours worked each day by each employee in each classification of work and the amount paid each employee for his work in each classification. Such records shall be open to the inspection and transcript of the Commissioner of Labor or his duly authorized representatives at any reasonable time. These payroll records shall not be destroyed or removed from the state for one year following completion of the improvement.

The Contractor and each Subcontractor shall post and keep posted in a conspicuous place or places at the construction site a copy or copies of prevailing rates of wages and working hours as prescribed in these Contract Documents.

If, during the life of this Contract, the prevailing hourly rate of wages is changed by the Department of Labor, such change shall not be the basis of any claim by the Contractor against the Owner, nor will deductions be made by the Owner against sums due the Contractor by reason of any such change.

The prevailing wage law does not prohibit payment of more than the prevailing rate of wages.

Pursuant to Kentucky Revised Statute 337.540, no laborer, workman, mechanic, helper, assistant, or apprentice shall be permitted to work more than 8 hours in one calendar day, nor more than 40 hours in one week, except in cases of emergency caused by fire, flood, or damage to life or property. Whenever work in excess of 8 hours per day or 40 hours per week is required, payment for overtime shall be at not less than one and one-half times the prevailing rate of wages.

R-2. PREVAILING WAGES. The following wage rate schedule is the prevailing wage rate determination made by the Department of Labor of the Commonwealth of Kentucky on the designated date, and shall be a part of the Contract.

(This page left blank intentionally)

KENTUCKY PREVAILING WAGE RATES

SEE FOLLOWING PAGES FOR  
PREVAILING WAGE SCALES IN EFFECT.

PLEASE GO TO THE FOLLOWING WEB ADDRESS TO SECURE THE FORM ON WHICH TO ENTER THE  
CERTIFIED PAYROLL INFORMATION:

<http://www.dol.gov/whd/forms/wh347.pdf>

(This page left blank intentionally)



**Matthew G. Bevin**  
Governor

**Jenean M. Hampton**  
Lt. Governor

**Kentucky Labor Cabinet**  
**Department of Workplace Standards**  
**Division of Employment Standards, Apprenticeship**  
**and Mediation**

1047 US Hwy 127 S STE 4  
Frankfort, Kentucky 40601  
Phone: (502) 564-3070  
Fax: (502) 696-1897  
www.labor.ky.gov

**Derrick K. Ramsey**  
Secretary

February 18, 2016

Megan de Sola  
Viox & Viox  
466 Erlanger Rd.  
Erlanger KY 41018

Re: Kenton County Fiscal Court, Latonia Lakes Street & Water Main Reconstruction

Advertising Date as Shown on Notification: February 26, 2016

Dear Megan de Sola:

This office is in receipt of your written notification on the above project as required by KRS 337.510 (1).

I am enclosing a copy of the current prevailing wage determination number CR 2-023, dated December 4, 2015 for KENTON County. This schedule of wages shall be attached to and made a part of the specifications for the work, printed on the bidding blanks, and made a part of the contract for the construction of the public works between the public authority and the successful bidder or bidders.

The determination number assigned to this project is based upon the advertising date contained in your notification. There may be modifications to this wage determination prior to the advertising date indicated. In addition, if the contract is not awarded within 90 days of this advertising date or if the advertising date is modified, a different set of prevailing rates of wages may be applicable. It will be the responsibility of the public authority to contact this office and verify the correct schedule of the prevailing rates of wages for use on the project. Your project number is as follows: 059-H-00646-15-2, Heavy/Highway

Sincerely,

Michael C. Donta  
Deputy Commissioner



(This page left blank intentionally)

**KENTUCKY LABOR CABINET  
PREVAILING WAGE DETERMINATION  
CURRENT REVISION  
LOCALITY NO. 023**

**KENTON COUNTY**

Determination No. CR 2-023 2015

**PROJECT NO. 059-H-00646-15-2**

Date of Determination: December 4, 2015

\_\_\_\_\_ BLDG      X   HH

This schedule of the prevailing rate of wages for Kenton County has been determined in accordance with the provisions of KRS 337.505 to 337.550. This determination shall be referred to as Prevailing Wage Determination No. CR 2-023 2015.

Apprentices shall be permitted to work as such subject to Administrative Regulations 803 KAR 1:010. Copies of these regulations will be furnished upon request to any interested person.

Overtime is to be computed at not less than one and one-half (1 1/2) times the indicated BASE RATE for all hours worked in excess of eight (8) per day, and/or in excess of forty (40) per week. However, KRS 337.540 permits an employee and employer to agree, in writing, that the employee will be compensated at a straight time base rate for hours worked in excess of eight (8) hours in any one calendar day, but not more than ten (10) hours worked in any one calendar day, if such written agreement is prior to the over eight (8) hours in a calendar day actually being worked, or where provided for in a collective bargaining agreement. The fringe benefit rate is to be paid for each hour worked at a straight time rate for all hours worked.

Fringe benefit amounts are applicable for all hours worked except when otherwise noted. Welders will receive rate for craft in which welding is incidental.

NOTE: The type of construction shall be determined by applying the following definitions:

**BUILDING CONSTRUCTION**

Building construction is the construction of sheltered enclosures with walk-in access for the purpose of housing persons, machinery, equipment, or supplies. It includes all construction of such structures, the installation of utilities and the installation of equipment, both above and below grade level, as well as incidental grading, utilities and paving.

**HIGHWAY CONSTRUCTION**

Highway construction includes the construction, alteration or repair of roads, streets, highways, runways, taxiways, alleys, trails, paths, parking areas, and other similar projects not incidental to building or heavy construction. It includes all incidental construction in conjunction with the highway construction project.

**HEAVY CONSTRUCTION**

Heavy projects are those projects that are not properly classified as either "building" or "highway". For example, dredging projects, water and sewer line projects, dams, flood control projects, sewage treatment plants and facilities, and water treatment plants and facilities are considered heavy.



\_\_\_\_\_  
Anthony Russell, Commissioner  
Department of Workplace Standards  
Kentucky Labor Cabinet

Determination No. CR 2-023 2015  
December 4, 2015

**ASBESTOS/INSULATION WORKERS:**

(Including duct (hot/cold), Pipe Insulator, pipe wrapping):

BASE RATE \$29.40  
 FRINGE BENEFITS 14.77

Hazardous Material Handlers: (Includes preparation, wetting, stripping, removal, scrapping, vacuuming, bagging & disposing of all insulation materials, whether they contain asbestos or nor, from mechanical systems):

BASE RATE \$23.60  
 FRINGE BENEFITS 9.80

**BOILERMAKERS:**

BASE RATE \$32.22  
 FRINGE BENEFITS 24.26

**BRICKLAYERS:**

Bricklayers: BUILDING

BASE RATE \$26.77  
 FRINGE BENEFITS 11.49

Tile Setters: BUILDING

BASE RATE \$27.44  
 FRINGE BENEFITS 10.87

Tile Finishers: BUILDING

BASE RATE \$22.90  
 FRINGE BENEFITS 10.87

Bricklayer: HEAVY

BASE RATE \$26.50  
 FRINGE BENEFITS 11.17

**CARPENTERS:**

Includes Form Work: BUILDING

BASE RATE \$23.85  
 FRINGE BENEFITS 12.37

Carpenters & Piledrivermen: HEAVY

BASE RATE \$27.05  
 FRINGE BENEFITS 9.69

Divers: HEAVY

BASE RATE \$40.58  
 FRINGE BENEFITS 9.69

Form Work Only: HEAVY

BASE RATE \$24.80  
 FRINGE BENEFITS 8.76

**CEMENT MASON / CONCRETE FINISHERS:**

BUILDING

BASE RATE \$22.00  
 FRINGE BENEFITS 12.55

HEAVY

BASE RATE \$25.75  
 FRINGE BENEFITS 8.60

**ELECTRICIANS:**

Electricians (includes low voltage);

BUILDING

BASE RATE \$27.03  
 FRINGE BENEFITS 17.02

Electricians: HEAVY

BASE RATE \$30.01  
 FRINGE BENEFITS 15.65



CR 2-023 2015  
 CLASSIFICATIONS

BASE RATES AND FRINGE BENEFITS

**ELECTRICIAN/LINE CONSTRUCTION:**

Linemen:		BASE RATE	\$30.50
		FRINGE BENEFITS	11.15
Equipment Operator:		BASE RATE	\$27.45
		FRINGE BENEFITS	10.51
Groundmen:		BASE RATE	\$19.83
		FRINGE BENEFITS	8.92
SOUND & COMMUNICATION TECHNICIAN:		BASE RATE	\$21.55
		FRINGE BENEFITS	8.46

**ELEVATOR MECHANICS:**

BASE RATE	\$41.26
FRINGE BENEFITS	28.385

**GLAZIERS:**

BASE RATE	\$25.00
FRINGE BENEFITS	12.60

**IRONWORKERS:**

Structural & Ornamental:		BASE RATE	\$26.40
		FRINGE BENEFITS	19.15
Fence Erector:		BASE RATE	\$22.70
		FRINGE BENEFITS	18.40

**REINFORCING:**

BASE RATE	\$27.00
FRINGE BENEFITS	19.00

**LABORERS / BUILDING:**

Mason Tender-Brick:	BUILDING	BASE RATE	\$21.55
		FRINGE BENEFITS	11.70
Pipelayer:	BUILDING	BASE RATE	\$20.36
		FRINGE BENEFITS	9.90
Power Tool Operator:	BUILDING	BASE RATE	\$28.29
		FRINGE BENEFITS	14.15
LABORER	COMMON OR GENERAL	BASE RATE	\$22.10
		FRINGE BENEFITS	11.70
Mason Tender-Cement/Concrete:		BASE RATE	\$25.10
		FRINGE BENEFITS	13.67

**LABORER / HEAVY:**

Concrete Worker & Grade Checker:	HEAVY	BASE RATE	\$22.30
		FRINGE BENEFITS	12.46
Tamper (hand held/walk behind):	HEAVY	BASE RATE	\$22.55
		FRINGE BENEFITS	12.46
Concrete Saw (hand held/walk behind) & Pipelayer:	HEAVY	BASE RATE	\$28.89
		FRINGE BENEFITS	9.85
Flagger & Landscaper:	HEAVY	BASE RATE	\$28.72
		FRINGE BENEFITS	9.85
Common or General:	HEAVY	BASE RATE	\$25.27
		FRINGE BENEFITS	8.34
Concrete Finishing:	HEAVY	BASE RATE	\$25.75
		FRINGE BENEFITS	9.85

Signal Person will receive the rate equal to the rate paid the laborer classification for which he or she is signaling

**MILLWRIGHTS:**

BASE RATE	\$27.55
FRINGE BENEFITS	15.39

**OPERATING ENGINEERS / BUILDING:**

Drill, Loader:	BUILDING	BASE RATE	\$28.85
		FRINGE BENEFITS	14.40
Crane, Forklift:	BUILDING	BASE RATE	\$31.10
		FRINGE BENEFITS	14.40
Oiler:	BUILDING	BASE RATE	\$25.13
		FRINGE BENEFITS	14.40
Backhoe/Excavator/Trackhoe:	BUILDING	BASE RATE	\$24.66
		FRINGE BENEFITS	10.81
Bulldozer:	BUILDING	BASE RATE	\$19.69
		FRINGE BENEFITS	4.71
Paver (Asphalt, Aggregate & Concrete):	BUILDING	BASE RATE	\$22.52
		FRINGE BENEFITS	4.00
Roller:	BUILDING	BASE RATE	\$23.60
		FRINGE BENEFITS	12.65

Cranes with boom 150 ft and over including JIB shall receive \$.50 above wage rate

**OPERATING ENGINEERS / HEAVY:**

Backhoe/Excavator/Trackhoe:	HEAVY	BASE RATE	\$33.34
		FRINGE BENEFITS	14.25
Crane; Forklift:	HEAVY	BASE RATE	\$27.66
		FRINGE BENEFITS	14.15
GROUP 1			
Drill; Pumpcrete; Roller (Bituminous):	HEAVY	BASE RATE	\$29.95
		FRINGE BENEFITS	14.40
GROUP 2			
Bobcat/Skid Steer/Skid Loader; Concrete Pump; Roller (Rock):	HEAVY	BASE RATE	\$27.26
		FRINGE BENEFITS	14.40
GROUP 3			
Articulating Truck Operator:	HEAVY	BASE RATE	\$27.68
		FRINGE BENEFITS	14.40
GROUP 4			
Pump; Roller (Earth):	HEAVY	BASE RATE	\$26.96
		FRINGE BENEFITS	14.40
Bulldozer:	HEAVY	BASE RATE	\$28.04
		FRINGE BENEFITS	13.00
Loader:	HEAVY	BASE RATE	\$29.37
		FRINGE BENEFITS	10.13
Mechanic:	HEAVY	BASE RATE	\$28.60
		FRINGE BENEFITS	11.83
Oiler:	HEAVY	BASE RATE	\$24.34
		FRINGE BENEFITS	13.00
Trencher:	HEAVY	BASE RATE	\$26.27
		FRINGE BENEFITS	12.37

Operators on cranes with booms 150 ft and over including jib, shall receive \$1.00 above Group 1 rate; 250 ft and over including jib shall receive \$1.50 above Group 1 rate. Combination Rate: All crane operators operating cranes where the length of the boom in combination with the length of the piling leads equal or exceeds 150 ft, shall receive \$1.00 above Group 1 rate.

**PAINTERS / BUILDING:**

Brush & Roller Only:	BUILDING	BASE RATE	\$23.39
		FRINGE BENEFITS	9.06
Spray Only:	BUILDING	BASE RATE	\$22.81
		FRINGE BENEFITS	11.87
Sign Painter & Erector:	BUILDING	BASE RATE	\$20.23
		FRINGE BENEFITS	3.25

**PAINTERS / HEAVY**

Bridge/Equipment Tender and/or Containment Builder:	HEAVY	BASE RATE	\$20.73
		FRINGE BENEFITS	8.71
Brush & Roller:	HEAVY	BASE RATE	\$23.39
		FRINGE BENEFITS	8.71

**PAINTERS / HEAVY CONTINUED:**

Spray:	HEAVY	BASE RATE	\$23.89
		FRINGE BENEFITS	9.06
Sandblasting & Water Blasting:	HEAVY	BASE RATE	\$24.14
		FRINGE BENEFITS	8.71
Bridge:	HEAVY	BASE RATE	\$24.39
		FRINGE BENEFITS	8.71

**PIPEFITTERS:**

BASE RATE	\$34.00
FRINGE BENEFITS	19.04

**PLUMBERS:**

BASE RATE	\$31.00
FRINGE BENEFITS	16.97

**PLASTERERS:**

BUILDING

BASE RATE	\$22.00
FRINGE BENEFITS	10.10

**ROOFERS**

BASE RATE	\$26.51
FRINGE BENEFITS	13.36

**SHEETMETAL WORKERS** (including metal roofs):  
 (including HVAC duct installation)

BASE RATE	\$26.86
FRINGE BENEFITS	17.08

**SPRINKLER FITTERS:**  
 (Fire Sprinklers)

BASE RATE	\$31.35
FRINGE BENEFITS	17.52

**TRUCK DRIVERS / BUILDING:**

10 Yard Truck: BUILDING

BASE RATE	\$16.27
FRINGE BENEFITS	1.50

Dump Truck: BUILDING

BASE RATE	\$24.35
FRINGE BENEFITS	14.59

**TRUCK DRIVER / HEAVY:**

Driver: HEAVY

BASE RATE	\$15.85
FRINGE BENEFITS	4.60

Euclid Wagon, End Dump, Lowboy, Heavy Duty Equipment, Tractor-Trailer Combination, & Drag:  
 HEAVY

BASE RATE	\$16.29
FRINGE BENEFITS	4.60

Dump Truck: HEAVY

BASE RATE	\$19.00
FRINGE BENEFITS	4.78

<b>BRICKLAYER:</b>	HIGHWAY	BASE RATE	\$26.50
		FRINGE BENEFITS	11.17
-----			
<b>CEMENT MASON/CONCRETE FINISHER:</b>	HIGHWAY	BASE RATE	\$25.75
		FRINGE BENEFITS	8.60
-----			
<b>CARPENTER &amp; PILEDRIVER:</b>	HIGHWAY	BASE RATE	\$27.27
		FRINGE BENEFITS	14.59
-----			
<b>DIVER:</b>	HIGHWAY	BASE RATE	\$40.58
		FRINGE BENEFITS	9.69
-----			
<b>ELECTRICIAN:</b>	HIGHWAY	BASE RATE	\$27.03
		FRINGE BENEFITS	17.02
-----			
<b>SOUND &amp; COMMUNICATION TECHNICIAN:</b>	HIGHWAY	BASE RATE	\$22.75
		FRINGE BENEFITS	10.08
-----			
<b>IRONWORKERS:</b>			
Fence Erector:	HIGHWAY	BASE RATE	\$23.76
		FRINGE BENEFITS	19.15
Structural:	HIGHWAY	BASE RATE	\$26.40
		FRINGE BENEFITS	19.15
Reinforcing:	HIGHWAY	BASE RATE	\$27.00
		FRINGE BENEFITS	19.00
-----			
<b>LABORERS / HIGHWAY:</b>			
<p>Group 1: aging and curing of concrete, asbestos abatement worker, asphalt plant, asphalt, batch truck dump, carpenter tender, cement mason tender, cleaning of machines, concrete, demolition, dredging, environmental-nuclear, radiation, toxic &amp; hazardous waste – level D, flagperson, grade checker, hand digging &amp; hand back filling, highway marker placer, landscaping, mesh handler &amp; placer, puddler, railroad, rip-rap &amp; grouter, right of way, sign, guard rail &amp; fence installer, signal person, sound barrier installer, storm &amp; sanitary sewer, swamper, truck spotter &amp; dumper, wrecking of concrete forms, general cleanup.</p>			
	HIGHWAY	BASE RATE	\$21.80
		FRINGE BENEFITS	11.96
<p>Group 2: batter board man (sanitary storm sewer), brickmason tender, mortar mixer operator, scaffold builder, Burner &amp; welder, bushhammer, chainsaw operator, concrete saw operator, deckhand scow man, dry cement Handler, environmental – nuclear, radiation, toxic &amp; hazardous waste – Level C, forklift operator for masonry, form setter, green concrete cutting, hand operated grouter &amp; grinder machine operator, jackhammer, pavement breaker, paving joint machine, pipelayer, plastic pipe fusion, power driven Georgia Buggy &amp; wheel barrow, power post hole digger, precast manhole setter, walk behind tamper, walk behind trencher, sand blaster, concrete chipper, surface grinder, vibrator operator, wagon driller.</p>			
	HIGHWAY	BASE RATE	\$22.05
		FRINGE BENEFITS	11.96

**LABORERS / HIGHWAY CONTINUED:**

Group 3: asphalt lutemen & raker, gunnite nozzleman, gunnite operator & mixer, group pump operator, side rail setter, rail paved ditches, screw operator, tunnel (free air) water blaster:

HIGHWAY	BASE RATE	\$22.10
	FRINGE BENEFITS	11.96

Group 4: Caisson worker (free air), cement finisher, environmental-nuclear, radiation, toxic & hazardous waste Levels A & B, miner & driller (free air), tunnel blaster & tunnel mucker (free air), directional & horizontal boring, air Track drillers (all types), powderman & blasters, troxler & concrete tester if Laborer is utilized.

HIGHWAY	BASE RATE	\$22.70
	FRINGE BENEFITS	11.96

**OPERATING ENGINEERS/ HIGHWAY**

GROUP 1: Air compressor on steel erection, barrier moving machine, boiler operator on compressor or generator when mounted on a rig, cableway, combination concrete mixer & tower, concrete plant (over 4 yd capacity), concrete pump, crane (all types including boom truck, cherry picker), crane-compact, track or rubber over 4,000 lbs capacity, cranes-self erecting, stationary, track or truck (all configurations), derrick, dragline, dredge (dipper, clam or suction), elevating grader or Euclid loader, floating equipment (all types), gradall, helicopter crew (operator-hoist or winch), hoe (all types, hoisting engine on shaft or tunnel work, hydraulic gantry (lifting system, industrial type tractor, jet engine dryer (D8 or D9) diesel tractor, locomotive (standard gauge), maintenance operator Class A, Mixer, Paving (single or double drum), mucking machine, multiple scraper, piledriving machine (all types), power shovel, prentice loader, quad 9 (double pusher), rail tamper (with auto lifting & aligning device), refrigerating machine (freezer operation), rotary drill on caisson work, rough terrain fork lift with winch/hoist, side boom, slip form paver, tower derrick, tree shredder, trench machine (over 24" wide), truck mounted concrete pump, tug boat, tunnel machine and/or mining machine, wheel excavator:

HIGHWAY	BASE RATE	\$33.24
	FRINGE BENEFITS	14.25

Group 2: asphalt paver, automatic subgrader machine, self-propelled (CMI type), bobcat type and/or skid steer loader with hoe attachment greater than 7,000 lbs., boring machine more than 48", bulldozer, endloader, hydro milling machine, horizontal directional drill (over 500,000 ft lbs thrust), kolman type loader (production type -dirt), lead greaseman, lighting & traffic signal installation equipment (includes all groups or classifications), material transfer equipment (shuttle buggy), asphalt pettibone-rail equipment, power grader, power scraper, push cat, rotomill (all),k grinder & planers of all types, trench machine (24" wide & under), vermeer type concrete saw:

HIGHWAY	BASE RATE	\$33.22
	FRINGE BENEFITS	14.25

Group 3: A-frame, air compressor on tunnel work (low pressure), asphalt plant engineer, bobcat and/or skid steer loader with or without attachments highway drills (all types), locomotive (narrow gauge), material hoist/elevator, mixer, concrete (more than one bag capacity), mixer, one bag capacity (side loader), power boiler (over 15 lbs pressure), pump (4" & over discharge), roller, asphalt, rotovator (lime soil stabilizer), switch & tie tampers (without lifting & aligning device), utility operator (small equipment), welding machines:

HIGHWAY	BASE RATE	\$32.18
	FRINGE BENEFITS	14.25

Group 4: backfiller, ballast re-locator, bars, joint & mesh installing machine, batch plant, boring machine operator (48" or less), bull floats, burlap & curing machine, concrete plant (cap. 4 yd & under), concrete saw (multiple), conveyor (highway), form trencher, hydro hammer, hydro seeder, pavement breaker, plant mixer, post driver, post hole digger (power auger), power bursh burner, power form handling equipment, road widening trencher, roller (brick, grade & macadam), self-propelled power spreader & power subgrader, steam fireperson, tractor (pulling sheepfoot, roller or grader), vibratory compactor with integral power:

HIGHWAY	BASE RATE	\$31.00
	FRINGE BENEFITS	14.25

**OPERATING ENGINEERS / HIGHWAY CONTINUED:**

Group 5: compressor (portable, sewer, heavy & highway), drum fireperson (asphalt), generator, masonry fork lift, inboard-outboard motor boat launch, masonry fork lift, oil heater (asphalt plant), oiler, power driven heater, power sweeper & scrubber, pump (under 4" discharge), signalperson, tire repairperson, VAC/ALLS:

HIGHWAY	BASE RATE	\$25.54
	FRINGE BENEFITS	14.25

GROUP 6: Master mechanic & boom from 150 to 180:

HIGHWAY	BASE RATE	\$33.59
	FRINGE BENEFITS	14.25

Group 7: Boom from 180 & over:

HIGHWAY	BASE RATE	\$33.84
	FRINGE BENEFITS	14.25

Cranes with booms 150 ft & over including JIB and where length of the boom in combination with the length of the piling leads equals or 150 ft - \$1.00 over Group 1 rate.

**PAINTERS:**

Bridge:	HIGHWAY	BASE RATE	\$24.39
		FRINGE BENEFITS	9.06

Bridge equipment tender & containment builder:

HIGHWAY	BASE RATE	\$20.73
	FRINGE BENEFITS	9.06

Brush & Roller:	HIGHWAY	BASE RATE	\$23.39
		FRINGE BENEFITS	9.06

Sandblasting & water blasting:	HIGHWAY	BASE RATE	\$24.14
		FRINGE BENEFITS	9.06

Spray:	HIGHWAY	BASE RATE	\$23.89
		FRINGE BENEFITS	9.06

<b>PLUMBERS:</b>	HIGHWAY	BASE RATE	\$29.80
		FRINGE BENEFITS	17.79

**TRUCK DRIVERS**

Group 1: driver:	HIGHWAY	BASE RATE	\$15.85
		FRINGE BENEFITS	4.60

Group 2: Euclid wagon, end dump, lowboy, heavy duty equipment, tractor trailer combination & drag:

HIGHWAY	BASE RATE	\$16.29
	FRINGE BENEFITS	4.60

End of Document  
 CR 2-023 2015  
 DECEMBER 4, 2015

(This page left blank intentionally)



# **TECHNICAL SPECIFICATIONS**

(This page left blank intentionally)

## **DIVISION 1 – GENERAL REQUIREMENTS**

(This page left blank intentionally)

## SECTION 01010

### SUMMARY OF WORK PERTAINING TO STREET CONSTRUCTION

#### PART 1 – GENERAL

##### 1.1 DESCRIPTION OF WORK

- A. The Work to be performed under this Contract consists of providing all labor, equipment, materials, supplies, tools, and supervision necessary to complete the installation of the storm sewer and reconstruction of the roadways including, excavation, storm sewer, full depth pavement reclamation, restoration, erosion control and all other appurtenances as shown on the Contract Documents prepared by Viox & Viox, Inc.
- B. The Work is generally located in the Latonia Lakes subdivision, (off of KY 16 at the intersection of Clubhouse Drive).

##### 1.2 WORK BY OWNER

- A. OWNER will perform certain activities in connection with the Work as follows:
  - 1. Provide all required permits for the construction of the project, including submittal of the NOI prior to the start of construction.
  - 2. Provide Survey Control Points on plan.

##### 1.3 SEQUENCE OF WORK

- A. The CONTRACTOR shall submit to the OWNER for approval a written schedule and sequence for proposed operation which outlines significant phases of the Work.

##### 1.4 CONTRACTOR'S USE OF SITE

- A. General:
  - 1. CONTRACTOR shall conduct the Work in such a fashion that the impact from construction to residents shall be at a minimum.
- B. CONTRACTOR shall:
  - 1. Assume full responsibility for protection and safekeeping of products stored on and off premises.
  - 2. Move stored products that interfere with the operation of OWNER and/or property OWNERS.

3. Obtain and pay for all additional storage or work areas required for his operations.
4. Not interfere with operation of OWNER and/or property OWNER.
5. Provide all tools, ladders, equipment, etc. for CONTRACTOR's work and the work of all his SUB-CONTRACTORS.
6. CONTRACTOR shall assume full responsibility for the preservation of all public and private property or facility on or adjacent to the site. If any direct or indirect damage is done by or on account of any act, omission, neglect or misconduct in the execution of the Work by the CONTRACTOR, it shall be restored by the CONTRACTOR, at his sole expense, to a condition equal to that existing before the damage was done.

C. Limits on CONTRACTOR'S use of site are:

1. CONTRACTOR and all personnel shall be restricted to the right of way areas as shown on the plans and designated by the OWNER.
2. CONTRACTOR shall not, except after written consent from proper parties, enter or occupy privately-owned land with men, tools, materials or equipment, except on easements provided herein.
3. CONTRACTOR shall ensure that all utilities are in good working condition for use by the OWNER'S personnel at all times unless written permission is received from the OWNER for temporary outages.
4. CONTRACTOR shall be responsible for any damage resulting from construction activities.

1.5 EASEMENTS AND RIGHTS-OF-WAY

- A. Easements and rights-of-way are provided by OWNER as shown on the Drawings. Confine construction operations within the easements indicated on the Drawings or as directed by the OWNER. Use due care in placing construction tools, equipment, excavated materials and pipeline materials and supplies in order to avoid damage to property and interference with traffic. The CONTRACTOR shall provide land required for storage of his construction materials and/or any temporary construction facilities or where construction operation must move beyond easement boundaries provided by the OWNER. The CONTRACTOR shall submit copies of all separate agreements with property OWNERS to the ENGINEER. CONTRACTOR shall restore all lands required outside the easement boundaries provided by the OWNER, at his sole expense, to a condition equal to that existing before the Work was started.
- B. Within Highway Rights-of-Way: Permits have been obtained by OWNER.

- C. All Work performed and all operations of CONTRACTOR, its employees, or SUB-CONTRACTORS within the limits of rights-of-way shall conform to the requirements as stated in this contract.

1.6 NOTICES TO OWNERS AND AUTHORITIES OF PROPERTIES ADJACENT TO THE WORK

- A. Notify OWNERS of adjacent property and utilities when prosecution of the Work may affect them.
- B. When it is necessary to temporarily obstruct access to property, or when any utility service connection must be interrupted, give notices sufficiently in advance to enable the affected persons to provide for their needs. Conform notices to any applicable local ordinances and, whether delivered orally or in writing, include appropriate information concerning the interruption and instructions on how to limit inconvenience caused thereby.
- C. Utilities and other concerned agencies shall be notified at least 48 hours prior to cutting or closing streets or other traffic areas or excavating near underground utilities or pole lines.

PART 2 – PRODUCTS (NOT USED)

PART 3 – EXECUTION (NOT USED)

++END OF SECTION++

(This page left blank intentionally)



## SECTION 01015

### SUMMARY OF WORK PERTAINING TO WATER MAIN CONSTRUCTION

1. GENERAL DESCRIPTION OF WORK. The Work to be performed under these Contract Documents is generally described as follows: Furnishing all plant, materials, equipment, supplies, labor and transportation, including fuel, power, water, (except any materials, equipment, utility, or service, if any, specified herein to be furnished by the District), and performing all work required in the scope of work in the Contract, in strict accordance with the specifications, schedules, and drawings, all of which are made a part hereof and including such detail drawings as may be furnished by the District from time to time during the prosecution of the work in explanation of said drawings.

2. COORDINATION. Contractor shall plan, schedule, and coordinate its operations in a manner which will facilitate the simultaneous progress of the work included under other contracts outside the scope of these Contract Documents if applicable.

3. MATERIALS TO BE FURNISHED BY OWNER. If the Owner is supplying some of the materials for this project (eg. air release valves, meter materials) it shall be indicated on the bid item unit price sheet and Measurement and Payment Section 1025. Items will be available at the Owner's storage yard unless other provisions have been made.

#### 4. RESPONSIBILITY FOR MATERIALS AND EQUIPMENT.

4.01. Items Furnished by Owner. Contractor's responsibility for materials and equipment furnished by Owner shall begin at the point of delivery on acceptance by Contractor. Contractor shall carefully examine each shipment prior to acceptance and shall reject all defective items. Owner reserves the right, however, to accept items rejected by Contractor and to authorize their installation in the Work.

Defective materials and equipment discovered after installation and prior to final acceptance of the Work, where the defect is of a nature not detectable by visual examination and other appropriate field inspection methods, shall be replaced by Owner, together with such additional materials and supplies as may be necessary for their replacement. Contractor shall furnish all necessary tools, equipment, and appliances, and perform all necessary labor, for the removal and replacement of such defective items in a manner acceptable to Owner; adjustment to the Contract Price for the costs of the removal and replacement shall be made in accordance with Article 11 of the General Conditions.

All materials and equipment furnished by Owner which disappear or are damaged after their acceptance by Contractor shall be replaced by and at the expense of Contractor. Replacements shall conform to the original procurement specifications.

Contractor shall be responsible for all unloading, reloading, transporting to the site, storage if necessary, re-handling, and installation.

All items shall be unloaded promptly after arrival. All charges for demurrage due to negligence or delay by Contractor shall be paid by Contractor. Equipment and materials shall be handled by methods which will prevent damage.

Equipment and materials shall be protected from exposure to the elements. All equipment shall be stored in accordance with the General Equipment Stipulations.

Contractor shall accept the risk of any delay in delivery of equipment or materials furnished by Owner, and if the Work is delayed, Contractor shall have no claim for damages or contract adjustment other than an extension of time and the waiving of liquidated damages occasioned by the delay.

All equipment shall be arranged and installed as indicated on the Drawings, and in conformity with installation drawings and instructions furnished to Owner by the manufacturer of the equipment.

4.02. Items Furnished by Contractor. Contractor shall be fully responsible for all materials and equipment which it has furnished.

5. OFFSITE STORAGE. Offsite storage arrangement shall be approved by Owner for all materials and equipment not incorporated into the Work but included in Applications for Payment. Such offsite storage arrangement shall be presented in writing and shall afford adequate and satisfactory security and protection. Offsite storage facilities shall be accessible to Owner.

6. SUBSTITUTES AND "OR-EQUAL" ITEMS. Provisions for evaluation of substitutes and "or-equal" items of materials and equipment are covered in Paragraph 6.05 of the General Conditions. Requests for review of equivalency will not be accepted by Owner from anyone except Contractor, and such requests will not be considered until after the Contract has been awarded.

7. PREPARATION FOR SHIPMENT. All materials shall be suitably packaged to facilitate handling and protect against damage during transit and storage. Painted surfaces shall be protected against impact, abrasion, discoloration, and other damage. All painted surfaces which are damaged prior to acceptance of equipment shall be repainted to the satisfaction of Owner.

Each item, package, or bundle of material shall be tagged or marked as identified in the delivery schedule or on the Shop Drawings. Complete packing lists and bills of material shall be included with each shipment.

8. SALVAGE OF MATERIALS AND EQUIPMENT. Existing materials and equipment removed, and not reused as a part of the Work, shall become Contractor's property, except the following items which shall remain Owner's property: Fire Hydrants, temporary plugs, and any unused materials supplied by the Owner.

Contractor shall carefully remove, in a manner to prevent damage, all materials and equipment specified or indicated to be salvaged and reused or to remain the property of Owner. Contractor shall store and protect salvaged items specified or indicated to be reused in the Work.

Salvaged items not to be reused in the Work, but to remain Owner's property, shall be delivered by Contractor in good condition to Owner's storage yard.

Any items damaged in removal, storage, or handling through carelessness or improper procedures shall be replaced by Contractor in kind or with new items.

Contractor may furnish and install new items instead of those specified or indicated to be salvaged and reused, in which case such removed items will become Contractor's property.

Existing materials and equipment removed by Contractor shall not be reused in the Work except where so specified or indicated.

9. EASEMENTS AND RIGHTS-OF-WAY. The easements and rights-of-way for the pipelines will be provided by Owner. Contractor shall confine its construction operations within the limits indicated on the Drawings. Contractor shall use due care in placing construction tools, equipment, excavated materials, and pipeline materials and supplies in order to avoid damage to property and interference with traffic.

9.01. On Private Property. Easements across private property are indicated on the Drawings. Contractor shall set stakes to mark the boundaries of construction easements across private property. The stakes shall be protected and maintained until completion of construction and cleanup.

Contractor shall not enter any private property outside the designated construction easement boundaries without written permission from the owner of the property.

Whenever the easement is occupied by crops which will be damaged by construction operations, Contractor shall notify the owner sufficiently in advance so that the crops may be removed before excavation or trenching is started. Contractor shall be responsible for all damage to crops outside the easement and shall make satisfactory settlement for the damage directly with the owner.

Where the line crosses fields which are leveled for irrigation or terraced, Contractor shall relevel irrigated fields and replace all terraces to their original or better condition, and to the satisfaction of the owner.

9.02. Work Within Highway and Railroad Rights-of-Way. Permits shall be obtained by Owner. All Work performed and all operations of Contractor, its employees, or Subcontractors within the limits of railroad and highway rights-of-way shall be in conformity with the requirements and be under the control (through Owner) of the railroad or highway authority owning, or having jurisdiction over and control of, the right-of-way in each case.

10. OPERATION OF EXISTING FACILITIES. The existing water transmission and distribution system must be kept in continuous operation throughout the construction period. No interruption will be permitted which adversely affects the degree of service provided. Provided permission is obtained from Owner in advance, portions of the existing facilities may be taken out of service for short periods corresponding with periods of minimum service demands. This may facilitate work at night or weekends which is considered incidental to the project.

Contractor shall provide temporary facilities and make temporary modifications as necessary to keep the existing facilities in operation during the construction period.

11. NOTICES TO OWNERS AND AUTHORITIES. Contractor shall, as provided in the General Conditions, notify owners of adjacent property and utilities when prosecution of the Work may affect them.

When it is necessary to temporarily deny access to property, or when any utility service connection must be interrupted, Contractor shall give notices sufficiently in advance to enable the affected persons to provide for their needs. Notices shall conform to any applicable local ordinance and, whether delivered orally or in writing, shall include appropriate information concerning the interruption and instructions on how to limit inconvenience caused thereby.

Utilities and other concerned agencies shall be notified at least 24 hours prior to cutting or closing streets or other traffic areas or excavating near underground utilities or pole lines.

12. LINES AND GRADES. All Work shall be done to the lines, grades, and elevations indicated on the Drawings.

Basic horizontal and vertical control points will be established or designated by Owner to be used as datums for the Work. All additional survey, layout, and measurement work shall be performed by Contractor as a part of the Work.

Contractor shall provide an experienced instrument person, competent assistants, and such instruments, tools, stakes, and other materials required to complete the survey, layout, and measurement work. In addition, Contractor shall furnish, without charge, competent persons and such tools, stakes, and other materials as Owner may require in establishing or designating control points, or in checking survey, layout, and measurement work performed by Contractor.

Contractor shall keep Owner informed, a reasonable time in advance, of the times and places at which it wishes to do Work, so that horizontal and vertical control points may be established and any checking deemed necessary by Owner may be done with minimum inconvenience to Owner and minimum delay to Contractor.

Contractor shall remove and reconstruct work which is improperly located.

13. CONNECTIONS TO EXISTING FACILITIES. Unless otherwise specified or indicated, Contractor shall make all necessary connections to existing facilities, including structures, drain lines, and utilities such as water, sewer, gas, telephone, and electric. In each case, Contractor shall receive permission from Owner or the owning utility prior to undertaking connections. Contractor shall protect facilities against deleterious substances and damage.

Connections to existing facilities which are in service shall be thoroughly planned in advance, and all required equipment, materials, and labor shall be on hand at the time of undertaking the connections. Work shall proceed continuously (around the clock) if necessary to complete connections in the minimum time. Operation of valves or other appurtenances on existing utilities, when required, shall be by or under the direct supervision of the owning utility.

14. UNFAVORABLE CONSTRUCTION CONDITIONS. During unfavorable weather, wet ground, or other unsuitable construction conditions, Contractor shall confine its operations to work which will not be affected adversely by such conditions. No portion of the Work shall be constructed under conditions which would affect adversely the quality or efficiency thereof, unless special means or precautions are taken by Contractor to perform the Work in a proper and satisfactory manner.

15. CUTTING AND PATCHING. As provided in General Conditions, Contractor shall perform all cutting and patching required for the Work and as may be necessary in connection with uncovering Work for inspection or for the correction of defective Work.

Contractor shall perform all cutting and patching required for and in connection with the Work, including but not limited to the following:

- Removal of improperly timed Work.
- Removal of samples of installed materials for testing.
- Alteration of existing facilities.
- Installation of new Work in existing facilities.

Contractor shall provide all shoring, bracing, supports, and protective devices necessary to safeguard all Work and existing facilities during cutting and patching operations. Contractor shall not undertake any cutting or demolition which may affect the structural stability of the Work or existing facilities without Owner's concurrence.

Materials shall be cut and removed to the extent indicated on the Drawings or as required to complete the Work. Materials shall be removed in a careful manner, with no damage to adjacent facilities or materials. Materials which are not salvable shall be removed from the site by Contractor.

All Work and existing facilities affected by cutting operations shall be restored with new materials, or with salvaged materials acceptable to Owner, to obtain a finished installation with the strength, appearance, and functional capacity required. If necessary, entire surfaces shall be patched and refinished.

16. ASBESTOS REMOVAL. If, during the progress of the Work, suspected asbestos-containing products are identified, Contractor shall stop work in the affected area and engage an asbestos removal Subcontractor to verify the materials and, if necessary, encapsulate, enclose, or remove and dispose of all asbestos in accordance with current regulations of the Environmental Protection Agency and the U. S. Department of Labor - Occupational Safety and Health Administration, the state asbestos regulating agency, and any local government agency. Payment for such work will be made by Change Order.

16.01. Subcontractor's Qualifications. The Subcontractor for asbestos removal shall be regularly engaged in this type of activity and shall be familiar with the regulations which govern this work. The Subcontractor shall demonstrate to the satisfaction of Owner that it has successfully completed at least three asbestos removal projects, that it has the necessary staff and equipment to perform the work, and that it has an approved site for disposal of the asbestos. The Subcontractor shall carry insurance as specified in the Supplementary Conditions.

16.02. Removal Methods. The asbestos removal Subcontractor shall submit a work plan of its proposed removal procedure to Owner before beginning work and shall certify that the methods are in full compliance with the governing regulations. The work plan shall cover all aspects of the removal, including health and safety of employees and building occupants, hygiene facilities, employee certification, clearance criteria, transportation and disposal, enclosure techniques, and other techniques appropriate for the proposed work.

17. CLEANING UP. Contractor shall keep the premises free at all times from accumulations of waste materials and rubbish. Contractor shall provide adequate trash receptacles about the site and shall promptly empty the containers when filled.

Construction materials, such as concrete forms and scaffolding, shall be neatly stacked by Contractor when not in use. Contractor shall promptly remove splattered concrete, asphalt, oil, paint, corrosive liquids, and cleaning solutions from surfaces to prevent marring or other damage.

Volatile wastes shall be properly stored in covered metal containers and removed daily.

Wastes shall not be buried or burned on the site or disposed of into storm drains, sanitary sewers, streams, or waterways. All wastes shall be removed from the site and disposed of in a manner complying with local ordinances and anti-pollution laws.

Adequate cleanup will be a condition for processing of progress payment applications.

18. APPLICABLE CODES. References in the Contract Documents to local codes mean the following:

- Kentucky Building Code
- Kentucky Plumbing Code
- National Electric Code
- BOCA Mechanical Code

Other standard codes which apply to the Work are designated in the Specifications.

19. PRECONSTRUCTION CONFERENCE. Prior to the commencement of Work at the site, a pre-construction conference will be held at a mutually agreed time and place. The conference shall be attended by:

- Contractor and its superintendent.
- Principal Subcontractors.
- Representatives of principal Suppliers and manufacturers as appropriate.
- Representatives of Owner.
- Government representatives as appropriate.
- Others as requested by Contractor or Owner.

Unless previously submitted to Owner, Contractor shall bring to the conference a preliminary schedule for each of the following:

- Progress.
- Procurement.
- Values for progress payment purposes.
- Shop Drawings and other submittals.

The purpose of the conference is to designate responsible personnel and establish a working relationship. Matters requiring coordination will be discussed and procedures for handling such matters established. The agenda will include:

- Contractor's preliminary schedules.
- Transmittal, review, and distribution of Contractor's submittals.
- Processing Applications for Payment.
- Maintaining record documents.
- Critical Work sequencing.
- Field decisions and Change Orders.
- Use of premises, office and storage areas, security, housekeeping, and Owner's needs.
- Contractor's assignments for safety and first aid.

Owner will preside at the conference and will arrange for keeping the minutes and distributing the minutes to all persons in attendance.

20. PROGRESS MEETINGS. Contractor shall schedule and hold regular progress meetings at least monthly and at other times as requested by Owner or required by progress of the Work. Contractor, Owner, and all Subcontractors active on the site shall be represented at each meeting. Contractor may at its discretion request attendance by representatives of its Suppliers, manufacturers, and other Subcontractors.

Contractor shall preside at the meetings. Meeting minutes will be prepared and distributed by Contractor. The purpose of the meetings will be to review the progress of the Work, maintain coordination of efforts, discuss changes in scheduling, and resolve other problems which may develop.

++END OF SECTION++

(This page left blank intentionally)



## SECTION 01025

### MEASUREMENT AND PAYMENT PART A - PERTAINING TO STREET CONSTRUCTION

#### 1.1. DESCRIPTION

- A. The items listed below in Article 1.4, refer to and are the same pay items listed in the Bid Form. It constitutes all of the items for the completion of the Work.
- B. Each lump sum and unit bid price will be deemed to include an amount considered by CONTRACTOR to be adequate to cover CONTRACTOR'S overhead and profit for each separately identified item.

#### 1.2. ENGINEER'S ESTIMATE OF QUANTITIES

- A. ENGINEER'S and OWNER's estimated quantities for unit price pay items, as listed in the Bid Form, are approximate only and are included solely for the purpose of comparison of Bids. OWNER does not expressly or by implication agree that the nature of the materials encountered below the surface of the ground or the actual quantities of material encountered or required will correspond therewith and reserves the right to increase or decrease any quantity or to eliminate any quantity as OWNER may deem necessary. CONTRACTOR will not be entitled to any adjustment in a unit bid price as a result of any change in an estimated quantity and agrees to accept the aforesaid unit bid prices as complete and total compensation for any additions caused by changes or alterations in the Work ordered by OWNER.

#### 1.3. RELATED PROVISIONS

- A. Payments to CONTRACTOR: Refer to General Conditions and Agreement.
- B. Changes in Contract Price: General Conditions.
- C. Schedule of Values: Section 01026.

#### 1.4. Unit Price

- A. Storm Sewer Improvements
  - 1. Safeload Existing Storm Sewer Pipe: Payment shall be made for each storm sewer to be safeloaded and shall include all labor, equipment and materials to "safeload" existing pipes with flowable fill.
  - 2. Remove Structure: Payment shall be made for each structure removed and shall include all labor, equipment and materials to remove and dispose offsite the structures as noted on the plan, and backfill the structures with compacted clay material.

3. 15" HDPE Pipe (AASHTO M294, ASTM F2306): Payment shall be made per lineal foot installed and shall include all labor, equipment, and materials for excavation, bedding, placement, and backfill of storm sewer piping as per plans, details, and specifications. This item considers restoration type as per detail both within and outside of pavement areas.
4. 18" HDPE Pipe (AASHTO M294, ASTM F2306): Payment shall be made per lineal foot installed and shall include all labor, equipment, and materials for excavation, bedding, placement, and backfill of storm sewer piping as per plans, details, and specifications. This item considers restoration type as per detail both within and outside of pavement areas.
5. 24" HDPE Pipe (AASHTO M294, ASTM F2306): Payment shall be made per lineal foot installed and shall include all labor, equipment, and materials for excavation, bedding, placement, and backfill of storm sewer piping as per plans, details, and specifications. This item considers restoration type as per detail both within and outside of pavement areas.
6. 4' Diameter Manhole: Payment shall be made for each installed manhole and shall include all labor, equipment, and materials for excavation, subgrade preparation, setting of manhole and all appurtenances, connection of pipe, and backfill. Manhole includes all items as per detail.
7. 3' X 3' (ID) Storm Box: Payment shall be made per each installed structure and shall include all labor, equipment and materials for excavation, subgrade preparation, setting structure and all appurtenances, connection of pipes, and backfill. 3' X 3' Catch Basin includes all items as per detail.
8. Small Headwall (12"-27"): Payment shall be made for each installed headwall and shall include all labor, equipment, and materials for excavation, subgrade preparation, setting of headwall, connection of pipe, and backfill.
9. Class III Channel Liner: Payment shall be made per cubic yard and shall include all labor, equipment, and materials to install a rip rap lined ditch at the outlet of every headwall per the plans and specifications.

B. Street Improvements

10. Clearing & Grubbing for Entire Project: Payment shall be made on a lump sum basis and shall include all labor, equipment, and materials required for all clearing in the disturbed area as shown on the plans, in accordance with the details and specifications. All stumps and debris shall be hauled off site.
11. Ditching and Grading: Payment shall be made on a lump sum basis and shall include all labor, equipment, and materials required for excavation of the drainage swales, construction of proposed roadway turn arounds, and excavation of cut materials or placement and compaction of fill on

the hillside slopes as shown on the plans and per geotechnical recommendations. Removal and reinstallation of any mailboxes within the disturbed limits shall be included in this bid item.

12. Milling of Existing Asphalt to Achieve Grade Change for Mix Design (Milling Depth Varies): Payment shall be made per ton and shall include all labor, equipment, and materials needed to mill and stockpile on site, existing asphalt pavement. The total milling depth in each area is noted in the plan set. The asphalt millings are to be stockpiled on site until they can be used per Items 5, 6, 16, and 18 below.
13. Provide and Place of Asphalt Millings or DGA to Achieve Grade Change for Mix Design: Payment shall be made per ton and shall include all labor, equipment, and materials needed to provide, spread and grade asphalt millings that were generated per Item 3 above. The total placement depth in each area is noted in the plan set.
14. Roadway Widening per Detail #3B: Payment shall be made per square yard and shall include all labor, equipment, and materials necessary to excavate existing material, and place asphalt millings generated per Item 3 above or imported DGA per the associated detail. The material generated from the excavation shall be disposed of off-site. The width and location of the pavement widening is shown in the plan set.
15. Roadway Widening per Detail #3A: Payment shall be made per square yard and shall include all labor, equipment, and materials necessary to excavate existing material, and asphalt base per the associated detail. The material generated from the excavation shall be disposed of off-site. The width and location of the pavement widening is shown in the plan set.
16. Full Depth Pavement Reclamation (8" Depth): Payment shall be made per square yard and shall include all labor, equipment, and materials for the full depth reclamation of the existing roadways. This item shall include all processes outlined in the appropriate details and in the specification book. The full depth reclamation process shall comply with the mix designs outlined in the plan set.
17. Full Depth Pavement Reclamation (10" Depth): Payment shall be made per square yard and shall include all labor, equipment, and materials for the full depth reclamation of the existing roadways. This item shall include all processes outlined in the appropriate details and in the specification book. The full depth reclamation process shall comply with the mix designs outlined in the plan set.
18. Full Depth Pavement Reclamation (12" Depth): Payment shall be made per square yard and shall include all labor, equipment, and materials for the full depth reclamation of the existing roadways. This item shall include all processes outlined in the appropriate details and in the specification book. The full depth reclamation process shall comply with the mix designs outlined in the plan set.

19. Asphalt Curing Seal (SS-1): Payment shall be made per ton and shall include all labor, equipment, and materials to provide and place an asphalt curing seal as shown on the plans and details, to KYTC specifications.
20. Dense Grade Aggregate: Payment shall be made per ton and shall include all labor, equipment, and materials necessary to provide and place Dense Grade Aggregate for use as the base material for the new proposed roadways and the proposed 1' shoulder on all streets. Material and placement shall follow requirements outlined in the specification book.
21. CL-2 Asphalt Base Course (PG 64-22): Payment shall be made per ton and shall include all labor, equipment, and materials for construction of an asphalt base course as shown on the plans and details, to KYTC specifications. Any tack coat necessary shall be incidental to this item.
22. CL-2 Asphalt Surface Course (PG 64-22): Payment shall be made per ton and shall include all labor, equipment, and materials for construction of an asphalt surface course as shown on the plans and details, to KYTC specifications. This bid item shall include a 5' driveway apron on all driveways per the appropriate details.
23. Leveling & Wedging of Asphalt or Concrete Driveways to Match Proposed Street Grade: Payment shall be made per ton and shall include all labor, equipment, and materials for construction of an asphalt taper to make up the grade difference between the existing driveways and the proposed street grade. The asphalt wedge does not include the 5' asphalt apron that is to be provided per items 14 and 15. The asphalt wedge is only to be provided on driveways that are existing asphalt or concrete.
24. Leveling & Wedging of Gravel Driveways to Match Proposed Street Grade (RAP or DGA): Payment shall be made per ton and shall include all labor, equipment, and materials for construction of a gravel taper to make up the grade difference between the existing driveways and the proposed street grade. The gravel wedge does not include the 5' asphalt apron that is to be provided per items 14 and 15. The gravel wedge is only to be provided on driveways that are gravel.

C. Erosion Control

25. Silt Trap Type B: Payment shall be made for each Type B silt trap installed and shall include all labor, equipment, and materials to install as per the plan and specifications, and removal after site is stabilized.
26. Silt Trap Type C: Payment shall be made for each Type C silt trap installed and shall include all labor, equipment, and materials to install as per the plan and specifications, and removal after site is stabilized.

27. Temporary Silt Fence: Payment shall be made per lineal foot of temporary silt fence installed and shall include all labor, equipment, and materials to install as per the plan and specifications, and removal after site is stabilized.
28. Erosion Control Blanket: Payment shall be made per square yard and shall include all labor, equipment, and materials for installing and staking erosion blanket as per plan and manufactures specifications. Erosion Control Blanket shall be East Coast Erosion Blankets ECSC-2 or approved equal.
29. Maintenance of Erosion Control BMP's as Outlined in SWPPP Book: Cleaning and repairing erosion control BMP's throughout the course of construction as defined in the SWPPP Manual.

D. Miscellaneous

30. Maintenance of Traffic: Payment shall be made on a lump sum basis and shall include all labor, equipment, and materials to adequately control traffic as outlined in KYTC's current Standard Specifications for Road and Bridge Construction.
31. Yard Restoration, Seed & Protect: Payment shall be made on a lump sum basis and shall include all labor, equipment, and materials for the placement of grass mix seed and straw according to specifications on all disturbed areas. This item shall also include the spreading of a 4" topsoil layer over all areas to be seeded.
32. Remove, Store & Reinstall Fence: Payment shall be made per lineal foot and shall include all labor, equipment and materials for the careful removal, storage, and replacement of existing fencing that will be disturbed. If fence is damaged, it will be at the contractor's expense to replace it in like kind. Fence will be fully reinstalled after project is completed.
33. Construction Staking: Payment shall be made on a lump sum basis and shall include the cost for any construction staking that is determined to be necessary by the contractor. Contractor will be provided with AutoCAD file prior to pre-construction meeting which can be used for staking purposes.
34. Mobilization (5% of Total Bid): Payment shall be made on a lump sum basis and shall be 5% of the total contractor bid.
35. Demobilization (2% of Total Bid): Payment shall be made on a lump sum basis and shall be 2% of the total contractor bid. Item will be paid upon the completion of all punch list items.

++ END OF PART A++

(This page left blank intentionally)

## SECTION 01025

### MEASUREMENT AND PAYMENT PART B - PERTAINING TO WATER MAIN CONSTRUCTION

1. SCOPE. This section covers methods of measurement and payment for items of Work under this Contract.
2. GENERAL. The total Contract Price shall cover all Work required by the Contract Documents. All costs in connection with the proper and successful completion of the Work, including furnishing all materials, equipment, supplies, and appurtenances; providing all construction plant, equipment, and tools; and performing all necessary labor and supervision to fully complete the Work, shall be included in the unit and lump sum prices bid. All Work not specifically set forth as a pay item in the Bid Form shall be considered a subsidiary obligation of Contractor and all costs in connection therewith shall be included in the prices bid. The Contractor shall be responsible for supplying all project materials, except for items supplied by the Owner as indicated in the Bid Item Descriptions below and on the bid form.
3. ESTIMATED QUANTITIES. All estimated quantities stipulated in the Bid Form or other Contract Documents are approximate and are to be used only (a) as a basis for estimating the probable cost of the Work and (b) for the purpose of comparing the bids submitted for the Work. The actual amounts of work done and materials furnished under unit price items may differ from the estimated quantities. The basis of payment for work and materials will be the actual amount of work done and materials furnished. Contractor agrees that it will make no claim for damages, anticipated profits, or otherwise on account of any difference between the amounts of work actually performed and materials actually furnished and the estimated amounts therefor.
4. EXCAVATION AND TRENCHING. Except where otherwise specified, the unit or lump sum price bid for each item of Work, which involves excavation, or trenching shall include all costs for such Work. No direct payment shall be made for excavation or trenching. All excavation and trenching shall be unclassified as to materials, which may be encountered; in addition, trenches shall be unclassified as to depth.
5. BID PRICES TO INCLUDE INCIDENTAL WORK. The bid prices will cover and include the cost and expense of all contingents, accessories and incidental work and material required to complete the improvement. This includes replacement of services, pavement, fences and any other objects which are affected in the process of construction on this work. It shall also include where necessary, watchmen, flagmen, barricades, red lights, all backfill material such as gravel, flowable fill and any temporary restoration, construction joints, finishing and curing concrete, dust control, maintenance of traffic, maintenance of existing sewage flow, provision for access to property, and many other incidents which occur on a normal construction job.

#### DESCRIPTION OF BID ITEMS

NOTE: Descriptions of each material can be found in Section 01600 Technical Provisions

6. PIPELINES. Pipelines which are to be paid for on a unit price basis shall be measured for payment on a horizontal plane after installation of the pipe. Where lines are laid to conform to stationed profiles, payment shall be made on linear quantities based on the pipeline stationing as determined by surveys made after installation.

The measurement of the length of each line or run of pipe of each size will begin and end at:

- a. The end of the pipe where connected to an existing pipe, fitting, or valve; or at the end of a dead-end run.
- b. The center lines intersection of the run and branch on tees, crosses, or laterals where a branch line connecting therewith is constructed under this Contract. Where a branch fitting is installed under this Contract, and the branch or connecting line is to be constructed by others at some future date or under another contract, the pay measurement will include the entire laying length of the branch or branches of such fitting.
- c. The measurement of each line of pipe of each size which is to be paid for on a unit price basis will be continuous through, and shall include the full laying lengths of, all fittings and valves installed between the ends of each line; except that the laying lengths of reducers and increasers will be divided equally between the connected pipe sizes. Connecting piping for fire hydrants will be paid under the unit price for fire hydrants.

**6.01 CLASS 50 or 52 DUCTILE IRON PIPE (ALL SIZES).** (Detail 103, 103a, 104, 104a, 110). Includes the specified pipe, polyethylene wrap, fittings, bends, tracing wire, excavation, labor, equipment, bedding, backfill disinfection, dechlorination, pressure testing, restoration of non-paved areas, etc. required to install the specified pipe at the location shown on the plans, or as directed, in accordance with the specifications and standard drawings complete and ready for use. Paid LINEAR FEET (LF).

**6.02.A CLASS 50 or 52 DUCTILE IRON PIPE (ALL SIZES) – INTERNAL RESTRAINED JOINT.** (Detail 103, 103a, 104, 104a, 110). Includes the specified pipe, polyethylene wrap, fittings, bends, tracing wire, excavation, labor, equipment, bedding, backfill, disinfection, dechlorination, pressure testing, restoration of non-paved areas, etc. required to install the specified pipe at the location shown on the plans, or as directed, in accordance with the specifications and standard drawings complete and ready for use. Paid LINEAR FEET (LF).

**6.02.B CLASS 50 or 52 DUCTILE IRON PIPE (ALL SIZES) –RESTRAINED JOINT.** (Detail 103, 103a, 104, 104a, 110). Includes the specified pipe, polyethylene wrap, fittings, bends, tracing wire, excavation, labor, equipment, bedding, backfill, disinfection, dechlorination, pressure testing, restoration of non-paved areas, etc. required to install the specified pipe at the location shown on the plans, or as directed, in accordance with the specifications and standard drawings complete and ready for use. Pipe gaskets shall develop a wedging action between pairs of high-strength stainless steel elements spaced around the gasket (Field Lok®, Fast-Grip® or approved equal gaskets). The bend shall be restrained using mechanical joint restraint devices consisting of multiple gripping wedges incorporated into a follower gland compatible with all mechanical joints (Megalug Series 1100®, MJ Field Lok® or approved equal) Paid LINEAR FEET (LF).

**6.03 C-900, C-909 Poly Vinyl Chloride (PVC) (ALL SIZES).** (Detail 103, 103a, 104, 104a, 111). Includes the specified pipe, polyethylene wrap, fittings, bends, excavation, labor, equipment, bedding, backfill, disinfection, pressure testing, restoration of non-paved areas, tracing wire etc. required to install the specified pipe at the location shown on the plans, or as directed, in



accordance with the specifications and standard drawings complete and ready for use. Paid LINEAR FEET (LF).

**6.03B C-900, C-909 Poly Vinyl Chloride (PVC) (ALL SIZES) – RESTRAINED JOINT.**

(Detail 103, 103a, 104, 104a, 111). Includes the specified pipe, polyethylene wrap, fittings, bends, tracing wire, excavation, labor, equipment, bedding, backfill, disinfection, pressure testing, restoration of non-paved areas, etc. required to install the specified pipe at the location shown on the plans, or as directed, in accordance with the specifications and standard drawings complete and ready for use. Pipe push on joints shall be restrained using devices designed and approved by the AWWA for C900 or C909 PVC pipe (Megalug Series 1600®, Eagle Loc 900® or approved equal restraint systems). Transitional joints shall be restrained using mechanical joint restraint devices designed for PVC pipe and consisting of multiple gripping wedges incorporated into a follower gland compatible with all mechanical joints (Megalug Series 2000®, MJ Field Lok® PV Series or approved equal) Paid LINEAR FEET (LF).

**6.04 CASING PIPE.** Includes the casing pipe (K.D.O.T. or Railroad Spec.), labor, equipment, excavation, backfill, restoration, etc. required to install the casing pipe at the location shown on the plans, or as directed, in accordance with the specifications and standard drawings complete and ready for use. Paid LINEAR FEET (LF).

- a. Crossings. Where tunneling is required in connection with railroad, highway, or primary road crossings, each crossing shall be measured for payment horizontally along the longitudinal center line of the enclosing conduit or pipe installed therein, from end to end of the enclosing conduit, or from end to end of the tunnel excavation where an enclosing conduit is not required. Each designated type of crossing shall include the following:
- b. Crossings in Earth Backfill Tunnel. The unit price bid for each crossing in earth backfill tunnel shall include all costs in connection with excavation and backfilling, the excess cost of installing pipe in tunnel above the amount bid for the pipe laid in open trench, all skids, jointing materials, stabilized sand backfill, and all other work for and in connection with the crossing, not paid for separately. Separate payment shall not be made for tunnel liner or supports which may be needed for Contractor's convenience; all such items shall be considered a subsidiary obligation of Contractor.
- c. Crossings in Conduit. The unit price bid for each crossing in pipe conduit or tunnel liner shall include all costs in connection with excavation and backfilling, pipe conduit or tunnel liner, the excess cost of installing pipe in pipe conduit or tunnel liner above the amount bid for the pipe laid in open trench, all skids, jointing materials, jacking pipe, jacking pits, sand backfill, end closures, and all other work for and in connection with the crossing, not paid for separately.

**6.05 CLASS 200 S.D.R. 9 HDPE (HIGH DENSITY POLY-ETHYLENE) PIPE (2").** (Detail 115). Includes the specified pipe, preparation of the host pipe, insertion of HDPE pipe into host pipe, fittings, bends, excavation, labor, equipment, bedding, backfill, disinfection, pressure testing, restoration of non-paved areas, tracing wire etc. District shall supply service line tees, saddle, curb stop and straight coupling. Contractor is required to install the specified pipe at the location shown on the plans, or as directed, in accordance with the specifications and standard drawings complete and ready for use. Paid LINEAR FEET (LF).

7. Connections to Existing Water Mains. Connections to existing water mains will be paid for at the lump sum prices bid. Each lump sum price named for a connection shall include all costs incurred for

making the connection over and above the price of the connecting piping in place. Each lump sum price shall include furnishing and installing the tapping sleeve and valve, fittings; all excavation, blocking and backfilling work; tapping of existing main; and all other costs not included under other bid items.

**7.01 CONNECT TO EXISTING MAIN/TIE-IN (ALL SIZES).** Includes all labor, equipment, excavation, fittings, sleeves, couplings, blocking, anchoring, polyethylene wrap, disinfection, pressure testing, backfill and restoration, required to make the connection as shown on the plans, and in accordance with the specifications. Pipe for connection shall be paid under pipe bid item and shall be measured thru connection fittings. Paid EACH (EA).

**7.02 TAPPING SLEEVE & VALVE (ALL SIZES)** Includes the District approved tapping sleeve and valve, polyethylene wrap, labor, equipment, excavation, blocking, anchoring, disinfection, backfill, restoration, etc. to install the specified fitting at the locations shown on the plans in accordance with the specifications and standard drawing complete and ready for use. Paid EACH (EA) when complete.

8. **Fire Hydrants.** Fire hydrants will be paid for at the unit price bid. The unit price named for each fire hydrant installation shall include all costs incurred in furnishing and installing the fire hydrant; auxiliary gate valve, all connecting piping to the adjacent water main, accessories, and appurtenances, concrete blocking behind and under the fire hydrant, drainage facilities, yard restoration and all other costs not included under other bid items.

**8.01 INSTALL FIRE HYDRANT ASSEMBLY.** (Detail 109). Includes all labor, equipment, excavation, concrete blocking, 6" Ductile Iron Resilient Seated Gate Valve, Valve box, 6" Ductile Iron Anchor Coupling, 6" ductile iron leads (restrained) Fire Hydrant, extensions, granular drainage material, backfill and yard restoration to install fire hydrant complete and in accordance with the specifications and standard drawings. Paid EACH (EA).

**8.02 INSTALL FUTURE FIRE HYDRANT VALVE.** (Detail 109). Includes all labor, equipment, excavation, 6" Ductile Iron Resilient Seated Gate Valve, Valve box, Plug, backfill and yard restoration to install future fire hydrant assembly complete and in accordance with the specifications and standard drawings. Paid EACH (EA).

**8.03 REMOVE FIRE HYDRANT.** Includes all labor, equipment, excavation, backfill and yard restoration to remove an existing fire hydrant, cap hydrant lead if necessary and return to the Northern Kentucky Water District warehouse. Paid EACH (EA).

**8.04 RELOCATE FIRE HYDRANT.** Includes allowing for Northern Kentucky Water District's Inspector to inspect the existing fire hydrant prior to reuse, returning unusable fire hydrants to the Northern Kentucky Water District Warehouse and picking up a replacement hydrant for use. Includes the labor, equipment, excavation, bedding, backfill, testing, disinfection, and yard restoration to relocate existing fire hydrant to valve, pipe, and anchoring tee as indicated on plans and on standard drawings contained in the plans. The pipe, valve and anchoring tee shall be paid under separate bid items when required. The Contractor to supply and install all anchoring devices, fire hydrant extensions, 6" ductile iron leads (restrained), concrete blocking, yard restoration, granular drainage material, etc, needed to install the fire hydrant complete and ready for use as shown on the plans, and in accordance with the specifications and standard drawings. Paid EACH (EA).

**8.05 ADJUST FIRE HYDRANT TO GRADE.** Includes the labor, equipment, excavation, bedding, backfill, testing, disinfection, and yard restoration to adjust the existing fire hydrant using the fire hydrant manufacturer's extension kit for adjustments of 18" or less. Adjustments greater than 18" require anchoring couplings and vertical bends to adjust to grade. The Contractor will supply and install all anchor couplings, bends, fire hydrant extension, concrete blocking, yard restoration, granular drainage material, etc, needed to adjust the fire hydrant complete and ready for use as shown on the plans, and in accordance with the specifications and standard drawings. Paid EACH (EA).

9. Valves. Sectionalizing valves in water mains will be paid for at the unit price bid for each size. The unit price shall include all costs incurred in completing the sectionalizing valve installation over and above the amount paid for piping in place. The unit price shall include furnishing and installing the sectionalizing valve, valve box, and appurtenances; excavation and backfill not included under piping; and all other costs not included under other bid items.

No separate payment will be made for fire hydrant auxiliary gate valves or tapping valves.

**9.01 DUCTILE IRON RESILIENT SEATED GATE VALVE (4", 6", 8", 12").** (Detail 105). Includes the specified valve, labor, equipment, excavation, polyethylene wrap, bedding, backfill, disinfection, pressure testing, restoration, etc. (contractor must supply mechanical joint restraints on restrained joint applications), required to install the specified valve at the location shown on the plans, or as directed, in accordance with the specifications and standard drawings complete and ready for use. All External Dome and Packing Bolts Shall be Stainless Steel. Paid EACH (EA).

**9.02 BUTTERFLY VALVE (16" AND LARGER).** Includes the labor, equipment, valve and appurtenances, material, excavation, polyethylene wrap, bedding, backfill, disinfection, pressure testing, restoration, etc. (contractor must supply mechanical joint restraints on restrained joint applications), required to install the specified valve at the location shown on the plans, or as directed, in accordance with the specifications and standard drawings complete and ready for use. Paid EACH (EA).

**9.03 DUCTILE IRON RESILIENT WEDGE GATE VALVE WITH BEVELED GEARING.** Ductile iron body, non-rising stem, open left, 2" square operating nut, epoxy coated, mechanical joint, inlet and outlet connections, O-ring type packing, resilient wedge, 250 PSI working pressure, and conforming in all other ways to AWWA Standard C515 American Flow Control 2500 Resilient Wedge Gate Valve or approved equal. Valve body to be assembled with stainless steel bolts grade 304 or better. Accessory package (glands, gaskets and bolts) shall not be included. Includes the specified valve, labor, equipment, excavation, polyethylene wrap, bedding, backfill, disinfection, pressure testing, restoration, etc. (contractor must supply mechanical joint restraints on restrained joint applications), required to install the specified valve at the location shown on the plans, or as directed, in accordance with the specifications and standard drawings complete and ready for use. All External Dome and Packing Bolts Shall be Stainless Steel. Paid EACH (EA).

## 10. SERVICES

**10.01 REPLACE and RECONNECT SERVICE LINE (3/4" THRU 2").** Includes the labor, equipment, excavation, bedding, backfill, and asphalt, concrete and yard restoration to install the service line at the locations shown on the plans or as directed, in accordance with the

specifications and standard drawings, complete and ready for use. Lead service lines encountered by the excavation shall be replaced from the main to and including the meter vault and meter setting. All service line material will be supplied by NKWD. Paid EACH (EA).

**10.02 REPLACE SERVICE LINE AND INSTALL WATER METER SETTING (3/4" THRU 2").** Includes the labor, equipment, excavation, bedding, backfill, and asphalt, concrete and yard restoration to install the service line, new meter vault and yoke setting at the locations shown on the plans or as directed, in accordance with the specifications and standard drawings, complete and ready for use. All service line material will be supplied by NKWD. Paid EACH (EA).

**10.03 RECONNECT COPPER SERVICE (3/4" THRU 2").** Includes the labor, equipment, excavation, bedding, backfill and asphalt, concrete and yard restoration to reconnect the service line at the locations shown on the plans or as directed, in accordance with the specifications and standard drawings, complete and ready for use. Lead service lines encountered by the excavation shall be replaced from the main to and including the meter vault and meter setting. All service line material will be supplied by NKWD. Paid EACH (EA).

**10.04 RELOCATE WATER METER SETTING.** Includes the labor, equipment, excavation, bedding, backfill and asphalt, concrete and yard restoration to install a new meter vault and yoke setting to the location shown on the plans or as directed, in accordance with the specifications and standard drawings complete and ready for use. All service line material will be supplied by NKWD. Paid EACH (EA).

**10.05 INSTALL WATER METER SETTING.** Includes the labor, equipment, excavation, bedding, backfill, testing, disinfection and asphalt, concrete and yard restoration to install a new meter vault and yoke setting to the location shown on the plans or as directed, in accordance with the specifications and standard drawings complete and ready for use. All service line material will be supplied by NKWD. Paid EACH (EA).

**10.06 ADJUST EXISTING WATER VALVE BOX TO GRADE.** Includes all labor, equipment, excavation, bedding, 2'x2'x4" concrete pad, backfill, testing, disinfection, and asphalt, concrete and yard restoration to install the valve box and valve toggle extensions (if required) and adjust the top of the box to finished grade complete and ready for use. Valve toggle extensions will be supplied by NKWD. Paid EACH (EA).

**10.07 ADJUST WATER METER TO GRADE.** Includes all labor, equipment, excavation, bedding, backfill, testing, disinfection, and asphalt, concrete and yard restoration to adjust the top of the box to finished grade complete and ready for use. Paid EACH (EA).

**10.08 REMOVE EXISTING CURB STOP/METER CROCK.** Includes the labor, equipment, excavation, backfill and asphalt, concrete or yard restoration to remove the existing curb stop or meter crock at the location shown on the plans or as directed, in accordance with the specifications and standard drawings. Paid EACH (EA).

**10.09 INSTALL TEMPORARY WATER SERVICE.** Includes the labor, equipment and materials for the installation and disinfection of temporary piping, flushing of temporary piping, removal of the existing meter and returning meter to the Owner, hooking up temporary water to meter setting, maintaining an uninterrupted water supply, repairs to any damaged or broken piping,

installation of meter and removal of all piping and fittings upon completion of the work, Paid LUMP SUM (LS).

## **11. MISCELLANEOUS**

**11.01 CONCRETE ENCASEMENT.** Includes the labor, equipment, excavation, backfill, concrete, restoration, etc. to construct the concrete encasement of the water main stream crossing as shown on the plans, and in accordance with the specifications and standard drawings. Paid LINEAR FEET (LF).

**11.02 4" UNDERDRAIN.** Includes the labor, equipment, excavation, bedding, materials, backfill, and restoration, etc.-required to install the underdrain at the location shown on the plans in accordance with the specifications and standard drawings complete and ready for use. Paid EACH (EA).

**11.03 PRESSURE REDUCING VALVE PIT.** Includes the labor, equipment, excavation, concrete pit construction, materials, pipe work, electrical work, backfill, restoration, etc.-required to install the specified pressure reducing valve pit at the location shown on the plans in accordance with the plans, specifications and standard drawings complete and ready for use. Paid EACH (EA).

**11.04 PLUG AND BLOCK (ALL SIZES).** This item shall include the specified plug, polyethylene wrap, labor, equipment, excavation, concrete, backfill and restoration required to install the plug and blocking at the location shown on the plans or as directed in accordance with the specifications. Paid EACH (EA).

**11.05 AIR RELEASE VALVE.** (Detail 106). This item shall include labor, equipment, excavation, polyethylene wrap, bedding, backfill, disinfection, pressure testing, restoration, etc. required to install the air release valve at the location shown on the plans or as directed in accordance with the specifications. All materials will be supplied by NKWD. Paid EACH (EA).

**11.06 ANCHORING TEE AND BLOCK (ALL SIZES).** Includes the specified anchoring tee, labor, equipment, excavation, polyethylene wrap, bedding, backfill, disinfection, pressure testing, restoration, etc. required to install the specified anchoring tee at the location shown on the plans, or as directed, in accordance with the specifications and standard drawings complete and ready for use. Paid EACH (EA).

**11.07 DUCTILE IRON TEE AND BLOCK (ALL SIZES).** Includes the specified ductile iron tee, labor, equipment, excavation, polyethylene wrap, bedding, backfill, disinfection, pressure testing, restoration, etc. required to install the specified tee at the location shown on the plans, or as directed, in accordance with the specifications and standard drawings complete and ready for use. Paid EACH (EA).

**11.08 DUCTILE IRON CROSS (ALL SIZES).** Includes the specified ductile iron cross, labor, equipment, excavation, polyethylene wrap, bedding, backfill, disinfection, pressure testing, restoration, etc. required to install the specified ductile iron cross at the location shown on the plans, or as directed, in accordance with the specifications and standard drawings complete and ready for use. Paid EACH (EA).

**11.09 REDUCER (ALL SIZES).** Includes the reducer, labor, equipment, excavation, polyethylene wrap, bedding, backfill, disinfection, pressure testing, restoration, etc. required to install the specified reducer at the location shown on the plans, or as directed, in accordance with the specifications and standard drawings complete and ready for use. Paid EACH (EA).

**11.10 FLUSHING DEVICE.** (Detail 113) Includes the labor, equipment, excavation, polyethylene wrap, bedding, backfill, disinfection, pressure testing, restoration, etc. required to install the specified flushing device at the location shown on the plans in accordance with the specifications and standard drawings complete and ready for use. Flushing device materials will be supplied by NKWD. Paid EACH (EA).

**11.11 TEST TAP.** Includes the labor, equipment, excavation, polyethylene wrap, bedding, backfill, disinfection, pressure testing, restoration, etc.-required to install the specified test tap at the location shown on the plans in accordance with the specifications and standard drawings complete and ready for use. Test Tap materials will be supplied by NKWD. Paid EACH (EA).

**11.12 STORM SEWER CONNECTION.** Includes all labor, equipment, excavation, bedding, backfill and materials required to make the connection to the existing combination manhole as shown on the plans and in accordance with the specifications of K.T.C.and Sanitation District No. 1. Paid EACH (EA).

**11.13 REMOVE EXISTING CATCH BASIN & RECONSTRUCT NEW DOUBLE CURB BOX INLET.** Includes all labor, equipment, excavation, backfill and materials to remove an existing catch basin, dispose of existing catch basin in a proper manner in accordance will all applicable local, state, or federal regulations and installation of a Standard Double Curb Box Inlet as per the detail in the construction drawings. All work shall also be in accordance with the specifications of K.T.C. and Sanitation District No. 1. Paid EACH (EA)

**11.14 REMOVE EXISTING STORM PIPE & CONSTRUCT HDPE STORM PIPE.** Includes all labor, equipment, excavation, bedding, backfill and materials to remove the existing storm sewer pipe and install new HDPE storm pipe as per plan. All debris materials shall be disposed of in a proper manner and shall be as directed by all applicable local, state or federal regulations. Installation of new HDPE storm pipe shall be in accordance with the Storm Sewer Pipe Bedding – Flexible Pipe (Plastic) detail on the construction drawings. All work shall also be in accordance with the specifications of K.T.C. and Sanitation District No. 1. Paid LINEAR FOOT (LF)

**11.15 SLEEVE OUT EXISTING TEE/CROSS/VALVE.** Includes all labor, equipment, excavation, specified pipe, fittings, couplings, polyethylene wrap, bedding, backfill, disinfection, pressure testing, restoration, etc. required to remove the existing tee/cross/valve and install a straight pipe at the location shown on the plans or as directed in accordance with the specifications. Paid EACH (EA).

**11.16 CORROSION TEST STATION.** Includes the labor, equipment and materials required to place test stations, and electrodes, in accordance with specifications and details. Paid EACH (EA).

**11.17 MAGNESIUM ANODES.** Includes the labor, equipment and materials required to place magnesium anodes and associated wiring, in accordance with specifications and details. Paid EACH (EA).

## 12. RESTORATION

12.01. Pavement Removal and Replacement. The unit prices per square yard for pavement removal and replacement shall be measured for (length x width) payment horizontally along the center line of the pipe, through manholes, and to the edge of the existing pavement; or, where the edge of the existing pavement is not clearly defined, to the edge of the pavement replacement. The unit prices bid for pavement removal and replacement shall include all costs in connection therewith, including cutting, removal, and disposal of old pavement; construction of new pavement; and all extra compaction effort required for backfill beneath pavement.

12.02 Miscellaneous Asphaltic Concrete Paving. Existing valve boxes shall be abandoned by removal or filling with concrete at the discretion of the District. This cost shall be incidental to any bid item associated with asphaltic concrete paving.

12.03. Sidewalk or Driveway Removal and Replacement. The unit prices per square yard bid for sidewalk or driveway removal and replacement shall include all costs involved in cutting and removing sidewalk or driveway, and all labor and materials required to replace the sidewalks.

Measurement for payment for sidewalk or driveway removal and replacement shall be on a square yard basis and shall include only the area actually removed and replaced, between joints, over the pipeline trench.

All costs involved in repairing or removal and replacement of existing sidewalk or driveway outside the specified pay limits, where damaged during the construction operations, shall be considered a subsidiary obligation of Contractor and shall be borne by Contractor.

12.04. MISCELLANEOUS CONCRETE. Concrete for encasement or blocking of pipe and fittings not included as parts of pipelines will be measured for payment as the actual volume of concrete placed within the limits as indicated or specified.

Concrete for total encasement shall be computed using the maximum allowable trench width (or pipe OD plus 24 inches where no maximum is specified), the minimum clear depth below the pipe, and the minimum cover over the pipe, less the volume occupied by the pipe itself.

Unless otherwise authorized by Owner, all additional concrete for encasement or blocking required outside the specified pay limits will be considered a subsidiary obligation of Contractor and no direct payment shall be made therefore.

All concrete which is required in connection with manholes or structures, pavement or sidewalk replacement, and other pay items shall be included in the lump sum or unit price bid for the pay item.

The unit price bid for miscellaneous concrete shall include concrete, reinforcing steel, forms, finishing, curing, and all other work or materials required to complete the concrete work.

Existing valve boxes shall be abandoned by removal or filling with concrete at the discretion of the District. This cost shall be incidental to any bid item associated with concrete paving or other concrete work.

**12.05 ASPHALTIC CONCRETE MILLING AND PAVING.** Includes the labor, equipment and materials required to perform any necessary milling, placing of asphalt to a depth of 1.5

inches in accordance with specifications and standard drawing #103A. Paid SQUARE YARD (SY).

**12.06 ASPHALTIC CONCRETE.** Includes the labor, equipment and materials required to perform any necessary removal and replacement of asphalt to a minimum depth of 6 inches or match existing and abandoning of valve boxes in accordance with specifications and standard drawing #103A. Paid SQUARE YARD (SY).

**12.07 ASPHALTIC CONCRETE - DRIVEWAY.** Includes the labor, equipment and materials required to perform any necessary removal and replacement of asphalt to match existing depth in accordance with specifications and standard drawing #103A. Culvert repair or replacement shall be considered incidental to driveway restoration. Paid SQUARE YARD (SY).

**12.08 ASPHALTIC CONCRETE. – WINTER CHARGE** In effect when a sole asphalt plant is operating within a 50 mile radius of the project. Includes the labor, equipment and materials required to perform any necessary removal and replacement of asphalt to a minimum depth of 6 inches and abandoning of valve boxes in accordance with specifications and standard drawing #103A. Paid SQUARE YARD (SY).

**12.09 CONCRETE PAVEMENT.** Includes the labor, equipment and materials required to remove and replace a minimum of 8” KDOT class A Concrete or to match existing, whichever is greater and abandoning of valve boxes in accordance with specifications and standard drawing #103A. Paid SQUARE YARD (SY).

**12.10 CONCRETE DRIVEWAY.** Includes the labor, equipment and materials required to remove and replace the driveway concrete to match existing depth. Culvert repair or replacement shall be considered incidental to driveway restoration. Paid SQUARE YARD (SY).

**12.11 CONCRETE CURBING.** Includes the labor, equipment and materials required to place KDOT class A Concrete to match existing in accordance with specifications and standard drawings. Paid LINEAR FEET (LF).

**12.12 CONCRETE SIDEWALK.** Includes the labor, equipment and materials required to remove and replace the sidewalk concrete to match existing depth. This item also includes any requirements to install sidewalk ramps per ADA standards. Paid SQUARE YARD (SY).

**12.13 GRAVEL DRIVEWAY/PARKING AREA.** Includes the labor, equipment and materials required to replace and grade gravel driveway to match existing depth. Paid SQUARE YARD (SY).

**12.14 BEST MANAGEMENT PRACTICE.** Includes the labor, equipment and materials required to conform and comply with the best management practices to control soil erosion as shown on the plans and specifications. Paid LUMP SUM (LS).

++ END OF PART B++

++ END OF SECTION++



## SECTION 01026

### SCHEDULE OF VALUES

#### PART 1 – GENERAL

##### 1.1 DESCRIPTION

- A. Submit to OWNER and ENGINEER for acceptance, a Schedule of Values allocated to the various portions of the Work.
- B. Upon request of OWNER or ENGINEER, support values with data which will substantiate their correctness.
- C. The accepted Schedule of Values shall be used as the basis for CONTRACTOR'S Applications for Payment. It may be used as a basis for negotiations concerning additional work or credits which may arise during the course of construction.

##### 1.2 FORM AND CONTENT OF SCHEDULE OF VALUES

- A. Type Schedule on 8-1/2 by 11-inch white paper. CONTRACTOR'S standard forms or automated printout will be considered for acceptance by OWNER.
- B. Identify Schedule with:
  - 1. Title of Project and location.
  - 2. Contract or Project Number.
  - 3. CONTRACTOR'S name and addresses.
  - 4. Date of Submittal.
- C. Use Table of Contents of the Specifications as basis for Schedule format and identify each item with number and title in the Table of Contents. List sub-items of major products or systems as appropriate or when requested by OWNER or ENGINEER.
- D. Schedule shall show a breakdown of labor, materials, equipment, and other costs used in preparation of the Bid. The Schedule shall be properly balanced between all items and between labor and material for each item. The OWNER and ENGINEER reserve the right to reject an unbalanced schedule.
- E. Costs shall be in sufficient detail to indicate separate amounts for each Section of the Specifications.
- F. Each item shall include a directly proportional amount of CONTRACTOR'S overhead and profit.

- G. For items on which progress payments will be requested for stored materials, break the values down into:
  - 1. Value of materials delivered and unloaded.
  - 2. Total installed value.
- H. The sum of the individual values shown on the Schedule of Values shall equal the total Contract Price.
- I. Each equipment item shall include all costs associated with starting and placing the equipment in operation, field testing the equipment, instructing the OWNER'S personnel in the proper operation and maintenance of the equipment, and providing the equipment operation and maintenance data. Payment for equipment items will not exceed ninety (90) percent of the total item amount (labor and material) until all start-up testing, training, and O&M data requirements including as-built Record Drawings associated with the equipment item have been completed.

1.3 SUBMITTAL

- A. Submit initial Schedule and revised acceptable Schedule within the time periods set forth in the General Conditions.

1.4 UPDATING

- A. Updating and resubmit Schedule of Values before the next Application for Payment when Charge Orders result in a change of Contract Price.

PART 2 – PRODUCTS (NOT USED)

PART 3 – EXECUTION (NOT USED)

++END OF SECTION++

## SECTION 01040

### PROJECT COORDINATION

#### PART 1 – GENERAL

##### 1.1 SCOPE

- A. As more fully set forth in Article 6 of the General Conditions, CONTRACTOR shall be solely responsible for coordination of all of the Work. He shall supervise, direct and cooperate fully with all SUB-CONTRACTORS, manufacturers, fabricators, suppliers, distributors, installers, testing agencies, and all others whose services, materials or equipment are required to ensure completion of the Work within the Contract Time.
- B. As more fully set forth in Article 7 of the General Conditions, CONTRACTOR shall cooperate with and coordinate his Work with the work of any other CONTRACTOR, utility service company or OWNER'S employees performing additional work related to the Project at the site.
- C. CONTRACTOR shall not be responsible for damage done by CONTRACTORS not under his jurisdiction. He will not be liable for any such loss or damage unless it is through the negligence of CONTRACTOR.
- D. CONTRACTOR shall maintain sufficient competent personnel, drafting equipment and supplies at the site for the purpose of preparing layout and coordination drawings. These drawings shall supplement the Contract Documents, and the working and Shop Drawings as necessary to correlate the work of various trades. Where such drawings are to be prepared by the mechanical, electrical, plumbing, or heating and ventilating SUB-CONTRACTORS, the CONTRACTOR will ensure that each SUB-CONTRACTOR maintains the required personnel and facilities at the site.
- E. CONTRACTOR shall also coordinate his Work with the work of others to assure compliance with schedules.
- F. CONTRACTOR shall attend and participate in all project coordination or progress meetings and report on the progress of all Work and compliance with schedules.

##### 1.2 COORDINATION MEETINGS

- A. Coordination meetings shall be held on a weekly basis unless it is mutually agreed by all parties that another schedule is suitable.

- B. The first meeting shall be held immediately upon execution of the Contract to allocate space requirements on site, construction requirements, Shop Drawing interchange among CONTRACTOR and SUB-CONTRACTORS, and future meetings. This meeting may be concurrent with preconstruction conference required by Article 2 of the General Conditions unless otherwise directed by ENGINEER.
- C. Purposes of the meetings are:
1. Establish and modify work schedules and agree upon an orderly sequence of operations acceptable to all.
  2. Review and adjust conflicts, work arrangements, and schedules to avoid delays and work stoppages.
  3. Discuss and prepare coordination drawings, as required to assist and guide the others.
- D. Meetings will be arranged through OWNER and shall be separate from and in addition to job progress meetings. The OWNER'S Resident Project Representative will keep notes, records and write minutes of the meetings.
- E. Representatives of the CONTRACTOR and appropriate SUB-CONTRACTORS at the meetings shall have the competence and authority to make any necessary decisions. Their decisions and statements shall commit the prime CONTRACTORS to the agreed procedures, sequence of operations and schedules.

PART 2 – PRODUCTS (NOT USED)

PART 3 – EXECUTION (NOT USED)

++END OF SECTION++

## SECTION 01050

### FIELD ENGINEERING

#### PART 1 – GENERAL

##### 1.1 DESCRIPTION

###### A. CONTRACTOR shall:

1. Be responsible for all construction staking.
2. Safeguard all points, stakes, grade marks, monuments, and bench marks made or established on the Work, re-establish same if disturbed and rectify all Work improperly installed because of not maintaining, not protecting or removing without authorization such established points, stakes, marks and monuments.

###### B. OWNER shall:

1. Provide civil, structural or other professional engineering services, specified or required, to evaluate CONTRACTOR'S construction methods.
2. When requested by ENGINEER, provide such facilities and assistance as may be necessary for ENGINEER to check line and grade points placed by CONTRACTOR. CONTRACTOR shall not do any excavation or embankment work until all cross-sectioning necessary for determining pay quantities has been completed and checked by ENGINEER.

##### 1.2 CONTRACTOR'S FIELD ENGINEER

###### A. CONTRACTOR shall employ and retain at the Site a field ENGINEER with experience and capability of performing all engineering tasks required of the CONTRACTOR. Tasks included are:

1. Provide daily reports of Project activity on standard form suitable to the OWNER, with all pertinent information pertaining to the Project. Daily reports shall be signed by a responsible member of the CONTRACTOR'S staff. Activity reports shall include the following:
  - a. Numbers of employees.
  - b. SUB-CONTRACTORS and number of SUB-CONTRACTOR'S employees.
  - c. Breakdown of employees by trade.
  - d. Major equipment and materials installed.
  - e. Major construction equipment utilized.

- f. Location of all areas in which construction was done.
  - g. Materials and equipment received.
  - h. Work and tests performed.
  - i. Weather conditions.
  - j. Accidents or safety violations.
  - k. Delays.
- 2. Check all formwork, reinforcing, inserts, structural steel, bolts, sleeves, piping, other materials and equipment.
  - 3. Maintain field office files and drawings. Record Drawings, and coordinate engineering services and SUB-CONTRACTORS. Prepare layout and coordination drawings for construction operations.
  - 4. Check and coordinate Work for conflicts and interferences and immediately advise ENGINEER of all discrepancies noted.
  - 5. Cooperate with ENGINEER in field inspections as required.

1.3 RECORDS

- A. CONTRACTOR shall maintain a complete, accurate log of all control and survey work as it progresses.

1.4 SUBMITTALS

CONTRACTOR shall:

- A. On request of ENGINEER, submit documentation to verify accuracy of field engineering work.

PART 2 – PRODUCTS (NOT USED)

PART 3 – EXECUTION (NOT USED)

++END OF SECTION++

## SECTION 01090

### REFERENCES

#### PART 1 – GENERAL

##### 1.1 DEFINITIONS

- A. General: Definitions of basic Contract terms are included in Article 1 of the General Conditions.
- B. Definitions of terms commonly found in the Specifications are as follows:
  - 1. Indicated: The term indicated refers to graphic representations, notes, or schedules on the Drawings, or to other paragraphs or schedules in the Specifications and similar locations in the other Contract Documents. Terms such as “shown”, “noted”, “scheduled”, and “specified” are used to help the user locate the reference. There is no limitation on the location.
  - 2. Installer (or applicator, or erector): an installer is the CONTRACTOR or another entity engaged by the CONTRACTOR, either as an employee or SUB-CONTRACTOR to perform a particular construction activity, including installation, erection, application or similar operations. Installers are required to be experienced in the operations they are engaged to perform.
    - a. The term “experienced”, when used with the term “installer”, means having successfully completed a minimum of five previous projects similar in size and scope to this Project; being familiar with the special requirements indicated; and having complied with the requirements of authorities having jurisdiction and of the Supplier of the product being installed.
  - 3. Trades: Use of a term such as “carpentry” does not imply that certain construction activities must be performed by accredited or unionized individuals of a corresponding generic name, such as “carpenter”. It also does not imply that requirements specified apply exclusively to trades persons or the corresponding generic name.
  - 4. Assigned Specialists: Certain Sections of the Specifications require that specific construction activities shall be performed by specialists who are recognized experts in those operations. Said specialists shall be engaged for those activities, and their engagement is a requirement over which CONTRACTOR has no option. These requirements shall not be interpreted to conflict with the enforcement of building codes and similar regulations governing the Work. Also, they are not intended to interfere with local trade-union jurisdictional settlements and similar conventions. Such assignments shall not relieve the CONTRACTOR of its responsibility for fulfilling the requirements of the contract Documents.

## 1.2 ABBREVIATIONS

A. Common abbreviations, which may be found in the Specifications, are:

alternating current	a-c
ampere	A
ante meridiem	am
average	avg
biochemical oxygen demand	BOD
brake horsepower	bhp
British thermal unit	Btu
Centigrade	C
company	Co
cubic inch	cu in
cubic foot	cu ft
cubic yard	cu yd
cubic feet per minute	cfm
cubic feet per second	cfs
decibel	db
degree Centigrade (or Celsius) (Say)	20 C
degree Fahrenheit (Say)	68 F
diameter	diam
direct current	d-c
dollars	\$
each	ea
efficiency	eff
Fahrenheit	F
feet per hour	fph
feet	ft
feet per minute	fpm
feet per second	fps
figure	Fig
flange	flg
foot-pound	ft-lb
gallon	gal
gallons per minute	gpm
gallons per second	gps
gram	g
Hertz	Hz
horsepower	hp
hour	hr
inch	in.
inch-pound	in.-lb
inside diameter	id
kilovolt-ampere	kva
kilowatt	kw
kilowatt-hour	kwhr
linear foot	lin ft
liter	l
maximum	max
mercury	Hg



milligram	mg
milligrams per liter	mg/l
milliliter	ml
millimeter	mm
million gallons per day	mgd
million gallon	mil
minimum	min
National Pipe Threads	NPT
net positive suction head	npsh
number	No.
ounce	oz.
outside diameter	od
parts per million	ppm
post meridiem	pm
pound	lb
pounds per square inch	psi
pounds per square inch absolute	psia
pounds per square inch gage	psig
pounds per square foot	psf
revolutions per minute	rpm
second	sec
specific gravity	sp gr
square	sq
square foot	sq ft
square inch	sq in
square yard	sq yd
standard	std
standard cubic feet per minute	scfm
total dynamic head	tdh
totally-enclosed-fan-cooled	tefc
volt	v

### 1.3 INDUSTRY STANDARDS

- A. Applicability of Standards: Except where the Contract Documents include more stringent requirements, applicable construction industry standards have the same force and effect as if bound or copied directly into the Contract Documents to the extent referenced. Such standards are made a part of the Contract Documents by reference.
- B. Publication Dates: For applicable publication dates, refer to General Conditions, Paragraph 3.02.A.1.
- C. Conflicting Requirements: Where compliance with two or more standards is specified and the standards establish different or conflicting requirements for minimum quantities or quality levels, refer to ENGINEER for a decision before proceeding.

- D. Copies of Standards: Each entity engaged in construction on the Project is required to be familiar with industry standards applicable to its construction activity. Copies of applicable standards are not bound with the Contract Documents. Where standards are needed to perform a required construction activity, CONTRACTOR shall obtain copies of same from the publication source.
- E. Abbreviations and Names: Whenever in these Specifications or the other Contract Documents references are made to the standards, specifications, or other published data of international, national, regional or local organizations, such organizations may be referred to by their acronym or abbreviation only. The following acronyms or abbreviations, which may appear in the Specifications, shall have the meanings indicated herein.

AA	Aluminum Association
AABC	Associated Air Balance Council
AAMA	American Architectural Manufacturers Association
AASHTO	American Association of State Highway and Transportation Officials
ACI	American Concrete Institute
ACS	American Chemical Society
AFBMA	Anti-Friction Bearing Manufacturers' Association
AGMA	American Gear Manufacturer's Association
AI	Asphalt Institute
AIChE	American Institute of Chemical Engineers
AISC	American Institute of Steel Construction
AISI	American Iron and Steel Institute
AITC	American Institute of Timber Construction
ALS	American Lumber Standards
AMA	Acoustical Materials Association
AMCA	Air Movement and Control Association
ANSI	American National Standards Institute
APA	American Plywood Association
API	American Petroleum Institute
APHA	American Public Health Association
AREA	American Railway Engineering Association
ARI	Air Conditioning and Refrigeration Institute
ASA	American Standards Association
ASAE	American Society of Agricultural Engineers
ASTM	American Society of Testing and Materials
ASCE	American Society of Civil Engineers
ASHRAE	American Society of Heating, Refrigerating and Air Conditioning Engineers
ASME	American Society of Mechanical Engineers
AWI	Architectural Woodwork Institute
AWPA	American Wood Preservers' Association
AWPB	American Wood Preservers Bureau
AWPI	American Wood Preservers' Institute
AWS	American Welding Society
AWWA	American Water Works Associations
BHMA	Builders Hardware Manufacturers' Association

CBMA	Certified Ballast Manufacturers' Association
CDA	Copper Development Association
CGA	Compressed Gas Association
CISPI	Cast Iron Soil Pipe Institute
CMAA	Crane Manufacturers' Association of America
CRSI	Concrete Reinforcing Steel Institute
EPA	Environmental Protection Agency
ETL	Engineering Test Laboratories
FCC	Federal Communications Commission
FEMA	Federal Emergency Management Agency
FGMA	Flat Glass Marketing Association
FM	Factory Mutual Association
FS	Federal Specification
GA	Gypsum Association
HEW	Department of Health, Education and Welfare
HI	Hydraulic Institute
HMI	Hoist Manufacturers' Institute
HUD	Department of Housing and Urban Development
ICBO	International Conference of Building Officials
ICEA	Insulated Cable Engineers' Association
IEEE	Institute of Electrical and Electronic Engineers
IES	Illuminating Engineering Society
IFI	Industrial Fasteners Institute
IRI	Industrial Risk Insurers
ISA	Instrument Society of America
ISO	Insurance Services Office
JIC	Joint Industry Conferences of Hydraulic Manufacturers
KDOH	Kentucky Department of Highways
MIA	Marble Institute of America
MS	Military Specifications
MMA	Monorail Manufacturers' Association
NAAMM	National Association of Architectural Metal Manufacturers
NACE	National Association of Corrosion Engineers
NARUC	National Association of Railroad and Utilities Commissioners
NBHA	National Builders Hardware Association
NEC	National Electric Code
NEMA	National Electrical Manufacturers Association
NESC	National Electric Safety Code
NFPA	National Fire Protection Association
NHLA	National Hardwood Lumber Association
NHPMA	Northern Hardwood and Pine Manufacturer's Association
NLMA	National Lumber Manufacturer's Association
NRCA	National Roofing Contractors Association
NSF	National Sanitation Foundation
NTMA	National Terrazzo and Mosaic Association
NWWDA	National Wood Window and Door Association
OECI	Overhead Electrical Crane Institute
OSHA	Occupational Safety and Health Administration
PCI	Precast Concrete Institute
PEI	Porcelain Enamel Institute
PPI	Plastic Pipe Institute

PS	Product Standards Section – U.S. Department of Commerce
RMA	Rubber Manufacturer’s Association
SAE	Society of Automotive Engineers
SCPRF	Structural Clay Products Research Foundation
SDI	Steel Deck Institute
SDI	Steel Door Institute
SIGMA	Sealed Insulating Glass Manufacturing Association
SJI	Steel Joist Institute
SMACNA	Sheet Metal and Air Conditioning National Association
SPI	Society of Plastics Industry
SSPC	Steel Structures Painting Council
SWI	Steel Window Institute
TEMA	Tubular Exchanger Manufacturer’s Association
TCA	Title Council of America
UL	Underwriter’s Laboratories, Inc.
USGS	United States Geological Survey
USPHS	United States Public Health Service
WCLIB	West Coast Lumber Inspection Bureau
WWEMA	Water and Wastewater Equipment Manufacturer’s Association
WWPA	Western Wood Products Association

PART 2 – PRODUCTS (NOT USED)

PART 3 – EXECUTION (NOT USED)

++END OF SECTION++

## SECTION 01210

### PRECONSTRUCTION CONFERENCE

#### PART 1 – GENERAL

##### 1.1 SCOPE

- A. Date, Time and Location: Conference will be held after execution of the Contract, but before any Work is started at the Site. ENGINEER will fix the date, time and location of the conference.
- B. ENGINEER will prepare agenda, preside at conference, record minutes to include significant proceedings and decisions, and distribute the minutes to all parties in attendance.
- C. Unless previously submitted to OWNER and ENGINEER, CONTRACTOR shall bring to the conference a preliminary schedule of each of the following:
  - 1. Construction (Progress) Schedule.
  - 2. Schedule of Shop Drawing and Sample submittals.
  - 3. Schedule of Values.
  - 4. Safety Manual tailored for this project
- D. CONTRACTOR shall provide any other data required, contribute appropriate items for discussion, and be prepared to discuss all items on agenda.

##### 1.2 REQUIRED ATTENDANCE

- A. Conference shall be attended by CONTRACTOR'S project manager, its superintendent and its principal SUB-CONTRACTORS and Suppliers as CONTRACTOR deems appropriate. Other attendees will be representatives of:
  - 1. OWNER.
  - 2. ENGINEER.
  - 3. Governmental agencies having any degree of control or responsibility, if available.
  - 4. Others as requested by OWNER, CONTRACTOR or ENGINEER.

1.3 PURPOSE

A. The purpose of the conference is to designate responsible personnel and establish working relationships. Matters requiring coordination will be discussed and procedures for handling such matters will be established. A complete agenda will be furnished to CONTRACTOR prior to the conference date. However, CONTRACTOR should be prepared to discuss all of the following:

1. Status of CONTRACTOR'S insurance.
2. Designation of responsible personnel.
3. SUB-CONTRACTORS.
4. Coordination with other CONTRACTORS, if any.
5. CONTRACTOR'S preliminary schedules.
6. Applications for Payment.
7. Requirements for copies of Contract Documents.
8. Use of Site, office and storage areas, security, housekeeping and OWNER'S needs.
9. CONTRACTOR(S) responsibilities for safety and first aid.
10. Major equipment deliveries and priorities.
11. Critical work sequencing.
12. Maintaining record documents.

PART 2 – PRODUCTS (NOT USED)

PART 3 – EXECUTION (NOT USED)

++END OF SECTION++

## SECTION 01220

### PROGRESS MEETINGS

#### PART 1 – GENERAL

##### 1.1 SCOPE

- A. Date and Time:
  - 1. Weekly Meetings: OWNER shall schedule and hold regular progress weekly meetings and at other times as required by the progress of the Work.
  - 2. Other Meetings: On request of ENGINEER, OWNER or CONTRACTOR.
- B. Place: Location to be determined as mutually agreed upon by all parties.
- C. OWNER will prepare agenda, preside at meetings, record minutes to include significant proceedings and decisions, and distribute the minutes to all parties in attendance.
- D. CONTRACTOR shall provide data required, contribute appropriate items for discussion, and be prepared to discuss all items on agenda.

##### 1.2 MINIMUM ATTENDANCE

- A. CONTRACTOR'S project manager and superintendent:
  - 1. When needed for the discussion of a particular agenda item, CONTRACTOR shall require representatives of SUB-CONTRACTORS or Suppliers to attend a meeting.
- B. OWNER'S representative.
- C. Others as appropriate.
- D. Representatives present for each party shall be authorized to act on their behalf.

##### 1.3 AGENDA

- A. Agenda will include, but will not necessarily be limited to, the following:
  - 1. Minutes of previous meeting.
  - 2. Progress of Work since last meeting.
  - 3. Proposed Work activities for forthcoming period.
  - 4. Problems, conflicts and observations.

5. Schedules, including off-site fabrication and delivery schedules. Corrective measures, if required.
6. Coordination of Work with others.
7. Change Orders.
8. Status of Shop Drawings.
9. Quality standards and control.
10. Safety and security concerns.
11. Updates to Construction Schedule.
12. Other business.

PART 2 – PRODUCTS (NOT USED)

PART 3 – EXECUTION (NOT USED)

++END OF SECTION++



## SECTION 01310

### CONSTRUCTION SCHEDULES

#### PART 1 – GENERAL

##### 1.1 DESCRIPTION

- A. Provide construction schedule which conforms to the requirements below, unless otherwise approved by OWNER or ENGINEER.
- B. Update schedules bi-weekly unless otherwise specified or directed by OWNER or ENGINEER.

##### 1.2 CONTENT

- A. Shop Drawing submittal dates and required approval dates.
- B. Product delivery dates.
- C. Factory and field testing dates.
- D. Dates for beginning and completing each phase of the Work by activity and by trades.
- E. Dates for completing all tie-ins, replacement or modifications to existing sewer system or facilities.

##### 1.3 FORMAT

- A. Type: Horizontal bar chart.
- B. Sheet Size: 24-inches by 36-inches.
- C. Time Scale: Indicate first date in each work week.
- D. Organization:
  - 1. Group Shop Drawing submittals and reviews into a separate subschedule.
  - 2. Group product deliveries into a separate subschedule.
  - 3. Group construction work into a separate subschedule by activity.
  - 4. Group critical activities which dictate the rate of progress into a separate subschedule.
  - 5. Organize each subschedule by Specification Section number.

E. Activity Designations: Show title and related Specification Section number.

1.4 SUBMITTALS

- A. Submit initial schedule 3 days prior to Preconstruction Conference, but no later than 30 days after date of execution of Agreement.
- B. Submit updated schedules at progress meetings or bi-weekly as specified. If a schedule remains unchanged from one period to the next, submit a written notice to that effect.
- C. Make submittals to OWNER and ENGINEER.
- D. Unless otherwise specified, submit three color copies of each schedule. One copy will be reviewed by the OWNER and returned. The other copies will be retained by the OWNER and ENGINEER.
- E. Attach a letter of transmittal to each submittal and include the following information in the letter:
  - 1. A listing of items which have changed since the last submittal.
  - 2. Discussion of problems causing delays, anticipated length of delays, and proposed countermeasures.
  - 3. Outstanding change orders.

PART 2 – PRODUCTS (NOT USED)

PART 3 – EXECUTION (NOT USED)

++END OF SECTION++

SECTION 01340

SHOP DRAWING PROCEDURES

PART 1 – GENERAL

1.1 DESCRIPTION

- A. Shop drawing procedures shall conform to requirements of the General Conditions and as described in this Section.
- B. Shop drawings shall be submitted for each type of equipment, piping, construction, operation, facility or system specified on the drawings or in the specifications.

1.2 PROCEDURE

- A. Submit Shop Drawings to OWNER.
- B. A letter of transmittal shall accompany each submittal. If data for more than one Section of the Specifications is submitted, a separate transmittal letter shall accompany the data submitted for each Section.
- C. At the beginning of each letter of transmittal provide a reference heading indicating the following:
  - 1. OWNER'S Name \_\_\_\_\_
  - 2. Project Name \_\_\_\_\_
  - 3. Contract Name/No. \_\_\_\_\_
  - 4. Transmittal No. \_\_\_\_\_
  - 5. Section No. \_\_\_\_\_
- D. If a Shop Drawing deviates from the requirements of the Contract Documents, CONTRACTOR shall specifically note each variation in his letter of transmittal.
- E. All Shop Drawings submitted for approval shall have a title block with complete identifying information satisfactory to the OWNER.

- F. All Shop Drawings submitted shall bear the stamp of approval and signature of the CONTRACTOR as evidence that they have been reviewed by the CONTRACTOR. Submittals without this stamp of approval will not be reviewed by the OWNER and will be returned to the CONTRACTOR. CONTRACTOR'S stamp shall contain the following minimum information:

Project Name: \_\_\_\_\_

CONTRACTOR'S NAME: \_\_\_\_\_

Date: \_\_\_\_\_

Item: \_\_\_\_\_

Specifications:

Section: \_\_\_\_\_

Page No.: \_\_\_\_\_

Para. No.: \_\_\_\_\_

Drawing No.: \_\_\_\_\_ of \_\_\_\_\_

Location: \_\_\_\_\_

Submittal No.: \_\_\_\_\_ Review Cycle No.: \_\_\_\_\_

Shop Drawing/Document Reference No.: \_\_\_\_\_

Company Name of Source: \_\_\_\_\_

Approved By: \_\_\_\_\_

- G. Shop Drawing Submittal Numbering and Identification:

1. In order to identify and track all Shop Drawing submittals as separate and unique items, the CONTRACTOR shall utilize a two number Shop Drawing submittal identification numbering system as follows:
  - a. The first number shall be the Submittal Number. The Submittal Number shall be a separate and unique Shop Drawing. No two Shop Drawings shall be submitted with or under the same Submittal Number, regardless of whether or not they are submitted together, at the same time, under the same Section Number and/or with the same transmittal letter. A Submittal Number shall be assigned to each unique and separate submittal that needs to be tracked as a separate and unique item. The Submittal Number shall be a two part, eight character, number assigned by the CONTRACTOR in the following manner:

- (1) The first part of the Submittal Number shall consist of five characters that pertain to the applicable Section Number. For example:

<u>Section Number</u>	<u>Submittal Number, First Part</u>
2220	02220
2900	02900

- (2) The second part of the Submittal Number shall consist of three digits (the numbers 001 to 999) to number each separate and unique item, document, or drawing submitted under each Section Number.
- (3) A dash shall separate the two parts of the Submittal Number.
- (4) A typical Submittal Number would be as follows:  
 02900-003;  
 02900 = Section for Landscape Planting;  
 and  
 003 = the third submittal under this section.

- b. The second number shall be the Review Cycle. The Review Cycle shall be a three-digit number indicating the initial submission or resubmission or resubmission of the same Shop Drawing submittal. For example:  
 001 = Initial submission.  
 002 = First resubmission.  
 003 = Second resubmission, etc.

- c. Some examples of typical Shop Drawing submittal identification numbers are:

<u>Submittal Number</u>	<u>Review Cycle</u>
02900-003	001

02900 = Section for Landscape Planting;  
 003 = the third submittal under this section; and,  
 001 = the initial submission of this submittal.

<u>Submittal Number</u>	<u>Review Cycle</u>
02200-001	001

02200 = Section for Earthwork, Grading and Backfilling;  
 001 = the first submittal under this section; and,  
 001 = initial submission for this submittal.

Submittal Number  
02200-001

Review Cycle  
002

02200 = Section for Earthwork, Grading and Backfilling;  
001 = the first submittal under this section; and,  
002 – first resubmission of this submittal.

- H. The CONTRACTOR shall initially submit to the OWNER a minimum of seven (7) copies of all submittals. The Resident Project Representative shall receive one copy only of each submittal which will be stamped “Preliminary – Not For Construction.”
- I. After the OWNER completes their review, Shop Drawings will be marked with one of the following notations:
1. Approved.
  2. Approved as Corrected.
  3. Revise and Resubmit.
  4. Not approved.
- J. If a submittal is acceptable, it will be marked “Approved” or “Approved as Corrected”. Four prints or copies of the submittal will be returned to the CONTRACTOR.
- K. Upon return of a submittal marked “Approved” or “Approved as Corrected”, the CONTRACTOR may order, ship or fabricate the materials included on the submittal, provided it is in accordance with the corrections indicated.
- L. If a Shop Drawing marked “Approved as Corrected” has extensive corrections or corrections affecting other drawings or Work, OWNER may require that the CONTRACTOR make the corrections indicated thereon and resubmit the Shop Drawings for record purposes. Such drawings will have the notation, “Approved as Corrected – Resubmit.”
- M. If a submittal is unacceptable, two (2) copies will be returned to CONTRACTOR with one of the following notations:
1. “Revise and Resubmit.”
  2. “Not Approved.”
- N. Upon return of a submittal marked “Revise and Resubmit”, the CONTRACTOR shall make the corrections indicated and repeat the initial approval procedure. The “Not Approved” notation is used to indicate material or equipment that is not acceptable. Upon return of a submittal so marked, the CONTRACTOR shall repeat the initial approval procedure utilizing acceptable material or equipment.

- O. Any related Work performed or equipment installed without an "Approved" or "Approved as Corrected" Shop Drawing will be at the sole responsibility of the CONTRACTOR.
- P. Shop Drawings shall be submitted well in advance of the need for the material or equipment for construction and with ample allowance for the time required to make delivery of material or equipment after data covering such is approved. The CONTRACTOR shall assume the risk for all materials or equipment which are fabricated or delivered prior to the approval of Shop Drawings. Materials or equipment will not be included in periodic progress payments until approval thereof has been obtained in the specified manner.
- Q. The OWNER will review and process all submittals promptly, but a first submission review period, not including mailing time, of 21 days shall be allotted by the CONTRACTOR when scheduling the Work. Shop Drawings being revised and resubmitted for review shall also have the same time allotted for OWNER'S review.
- R. It is the CONTRACTOR'S responsibility to review submittals made by his suppliers and SUB-CONTRACTORS before transmitting them to the OWNER to assure proper coordination of the Work. All submittals shall be thoroughly checked by the CONTRACTOR for accuracy and conformance to the intent of the Contract Documents before being submitted to the OWNER and shall bear the CONTRACTOR'S stamp of approval certifying that they have been so checked. Submittals without the CONTRACTOR'S stamp of approval will not be reviewed by the OWNER and will be returned to the CONTRACTOR. Incomplete or inadequate submittals will be returned for revision without review.
- S. The CONTRACTOR shall furnish required submittals with complete information and accuracy in order to achieve required approval of an item within three submittals.
- T. Where errors, deviations, and/or omissions are discovered at a later date in any of the submittals, the OWNER'S prior review of the submittals does not relieve the CONTRACTOR of the responsibility for correcting all errors, deviations, and/or omissions.
- U. Operation and Maintenance Manuals
  - 1. Two (2) preliminary copies of Operation and Maintenance Manuals, prepared specifically for this Project, shall be furnished for each item of equipment furnished under this Contract. The preliminary manuals shall be provided to the OWNER not less than 60 days prior to the start-up of the respective equipment.
  - 2. The preliminary manuals shall be reviewed by the OWNER prior to the CONTRACTOR submitting final copies for distribution to the OWNER. Following review of the preliminary copies of the Operation and Maintenance Manuals, one (1) copy will be returned to the CONTRACTOR with required revisions noted, or the acceptance of the OWNER noted.

3. Manuals shall contain complete information in connection with assembly, operation, lubrication, adjustment, wiring diagrams and schematics, maintenance, and repair, including detailed parts lists with drawings or photographs identifying the parts.
4. Manuals furnished shall be assembled and bound in separate volumes, properly noted with the project name, project number and CONTRACTOR'S name, by major equipment items or trades, and properly indexed to facilitate locating any required information.
5. The OWNER shall be the sole judge of the acceptability and completeness of the manuals and may reject any submittal for insufficient information included, incorrect references and/or the manner in which the material is assembled.
6. Following the OWNER'S review of the preliminary manuals, the CONTRACTOR shall submit five (5) copies of the final Operation and Maintenance Manuals to the OWNER. The manuals shall reflect the required revisions noted during the OWNER'S review of the preliminary documents. Failure of the final manuals to reflect the required revisions noted by the OWNER during a review of the Preliminary documents will result in the manuals being returned to the CONTRACTOR. Acceptable final Operation and Maintenance Manuals shall be provided not less than two week prior to equipment start-up. Acceptable final Operation and Maintenance Manuals shall be provided not less than two weeks prior to equipment start-up. In addition to hard copies, CONTRACTOR shall provide one electronic copy of the final operation and maintenance manual. Acceptable electronic formats are Adobe PDF, Microsoft Word, and AutoCAD

PART 2 – PRODUCTS (NOT USED)

PART 3 – EXECUTION (NOT USED)

++END OF SECTION++



## SECTION 01380

### CONSTRUCTION VIDEOTAPES AND PHOTOGRAPHS

#### PART 1 – GENERAL

##### 1.1 DESCRIPTION

- A. CONTRACTOR shall document existing site conditions, progress of the work, and the completed project through the use of videotapes and photographs. Videotapes and photographs shall be taken throughout the project work area and points of egress to the site. All existing structures or facilities affected by the Work shall also have videotapes and photographs taken of their before and after conditions.
- B. The OWNER shall be present during the videotaping and photographic work and shall determine the limits at each location.
- C. All photographs shall be in digital format with a time and date stamp. Photographs shall be a minimum of 3.0 mega pixels.
- D. All videotapes shall be color VHS or DVD and be of broadcast quality.
- E. All photographs and videos become the property of the OWNER and may be reproduced and used as necessary.

##### 1.2 PRECONSTRUCTION VIDEOTAPES AND PHOTOGRAPHS

- A. Before starting construction, videotape and take photographs of the site proposed to be disturbed and all areas of egress to the site, as directed by OWNER. The purpose of these videotapes and photographs is to document existing physical conditions at the site and its surrounding property.
  - 1. Provide one copy of the videotape and pictures to the OWNER prior to construction.
  - 2. CONTRACTOR shall audibly record a brief description of each videotape, the date and time of the recording, and subject location.

##### 1.3 PERIODIC CONSTRUCTION PHOTOGRAPHS

- A. Photos shall be taken as necessary to show general progress of the Work.
- B. Photographs shall be taken of all questionable site conditions that may affect the proposed work or design intent.
- C. OWNER will approve the views to be taken and select the time at which they will be taken.

1.4 FINAL COMPLETION VIDEOTAPES AND PHOTOGRAPHS

- A. OWNER will direct photographer for desired vantage points.
- B. Following completion of the Work:
  - 1. Videotape all disturbed areas of the site and all areas of egress to the site as directed by OWNER in the same areas as the preconstruction video. The purpose of these videotapes is to document the physical condition at each site and surrounding property at the completion of work. CONTRACTOR shall audibly record a brief description of each videotape location and the date and time of the recording.

1.3 SUBMITTALS

- A. Provide digital files of each photograph to the OWNER and ENGINEER as soon as they are available. Each digital file shall be labeled with the following information:
  - 1. Date photograph taken.
  - 2. Title of Project.
  - 3. Description of view shown in photograph.
  - 4. Numbered identification of exposure.
- B. Following substantial completion of the work and after final completion photographs have been taken, provide a CD copy of all digital photographs taken for the Work. Submit two copies of CDs.
- C. Submit two copies of each videotape as soon as they are available. Each videotape shall be labeled with the following information:
  - 1. Date video was taken.
  - 2. Title of Project.
  - 3. Location of taping.

PART 2 – PRODUCTS (NOT USED)

PART 3 – EXECUTION (NOT USED)

++END OF SECTION++

## SECTION 01410

### TESTING LABORATORY SERVICES

#### PART 1 – GENERAL

##### 1.1 DESCRIPTION

- A. The CONTRACTOR is required to contract with a KYTC pre-qualified geotechnical engineer to perform all geotechnical testing and laboratory services as specified for the street construction. Thelen Associates, a Division of Geotechnology, Inc., prepared street design and specifications for this project.
- B. Inspection, sampling and testing shall be as specified in the individual Sections. These include:
  - 1. Earthwork, Grading and Backfilling, Section 02200.
  - 2. Bituminous Concrete Pavement, Section 02400.
  - 3. Full Depth Reclamation, Section 02410.
- C. The OWNER will pay for the testing listed above except for repeat testing which results from the CONTRACTOR'S negligence or his repeated failure to meet Specification requirements.
- D. CONTRACTOR shall pay for:
  - 1. Tests not listed above.
  - 2. Test made for the CONTRACTOR'S convenience.
  - 3. Repeat tests required because of the CONTRACTOR'S negligence or repeated failure to meet Specification requirements.

##### 1.2 QUALIFICATIONS OF LABORATORY

- A. Where applicable, the testing laboratory will meet "Recommended Requirements for Independent Laboratory Qualification", latest edition, published by American Council of Independent Laboratories and the basic requirements of ASTM E 329 "Standards of Recommended Practice for Inspection and Testing Agencies for Concrete and Steel as Used in Construction".
- B. Testing equipment used by the laboratory will be calibrated at maximum 12 month intervals by devices of accuracy traceable to either National Bureau of Standards or accepted values of natural physical constants.

1.3 LABORATORY DUTIES

A. The testing laboratory will:

1. Cooperate with ENGINEER and CONTRACTOR and provide qualified personnel promptly on notice.
2. Perform specified inspections, sampling and testing of materials and methods of construction; comply with applicable standards; ascertain compliance with requirements of Contract Documents.
3. Promptly notify ENGINEER and CONTRACTOR of irregularities or deficiencies of Work which are observed during performance of services.
4. Promptly submit 5 copies of reports of inspections and tests to ENGINEER, including:
  - a. Date issued.
  - b. Project title and number.
  - c. Testing laboratory name and address.
  - d. Name of inspector.
  - e. Date of inspection or sampling.
  - f. Record of temperature and weather.
  - g. Date of test.
  - h. Identification of product and Specification Section.
  - i. Location in Project.
  - j. Type of inspection or test.
  - k. Results of tests and observations regarding compliance with Contract Documents.
5. Perform additional tests and services as required by OWNER.

1.4 CONTRACTOR'S RESPONSIBILITIES

A. The CONTRACTOR shall:

1. Cooperate with laboratory personnel, provide access to work, and to manufacturer's operations.
2. Provide to laboratory, preliminary representative samples of materials to be tested, in required quantities.

3. Furnish copies of product test reports.
4. Provide to the laboratory the preliminary design mix proposed for concrete, and other material mixes that require testing by the testing laboratory.
5. Furnish labor and facilities:
  - a. To provide access to Work to be tested.
  - b. To obtain and handle samples at the site.
  - c. To facilitate inspections and tests.
  - d. For laboratory's exclusive use for storage and curing of test samples.
  - e. Forms for preparing concrete test beams and cylinders.
6. Notify laboratory and ENGINEER sufficiently in advance of operations to allow for assignment of personnel and scheduling of tests.
7. Arrange with laboratory and pay for, additional samples and tests required for CONTRACTOR'S convenience.

PART 2 – PRODUCTS (NOT USED)

PART 3 – EXECUTION (NOT USED)

++END OF SECTION++

(This page left blank intentionally)

## SECTION 01510

### TEMPORARY CONSTRUCTION FACILITIES

#### PART 1 – GENERAL

##### 1.1 DESCRIPTION

- A. CONTRACTOR shall be responsible for all temporary construction facilities required for the Work. CONTRACTOR shall make all arrangements with utility service companies for temporary services and shall pay all costs associated therewith.
- B. Temporary construction facilities include:
  - 1. Water.
  - 2. Electricity and Lighting as specified in Section 01511.
  - 3. Heat, Weather Protection and Ventilation.
  - 4. Fire Protection.
  - 5. Sanitary and First Aid Facilities.
- C. CONTRACTOR shall abide by all rules and regulations of the utility service company or authority having jurisdiction.
- D. Sufficient temporary heat and ventilation shall be provided to assure safe working conditions and that no damage will occur to any of the Work. In addition, all enclosed areas shall be maintained at a minimum of 50 F, unless otherwise specifically accepted in the Specifications.
- E. CONTRACTOR shall provide all materials, equipment and power required for temporary electricity and lighting. Provide all outlets with circuit breaker protection and comply with ground fault protection requirements of NEC. CONTRACTOR shall pay operating costs for power. See Section 01511.
- F. CONTRACTOR shall provide suitably enclosed chemical or self-contained toilets shall be provided for the use of all the workers employed on the Work. Toilets shall be located near the Work site and secluded from observation insofar as possible. Toilets shall be serviced at regular intervals, kept clean and supplied throughout the course of the Work.
- G. CONTRACTOR shall furnish and maintain a safe drinking water supply readily available to all workers.

H. CONTRACTOR shall be responsible for all utility service costs except as otherwise noted until the Work is substantially complete. Included are all fuel, power, light, heat and other utility services necessary for execution, completion, testing and initial operation of the Work.

I. CONTRACTOR shall:

1. Completely remove temporary materials and equipment when their use is no longer required.
2. Clean and repair damage caused by temporary installations or use of temporary facilities.
3. Restore existing facilities used for temporary services to specified or to original condition.

PART 2 – PRODUCTS (NOT USED)

PART 3 – EXECUTION (NOT USED)

++END OF SECTION++



## SECTION 01511

### TEMPORARY ELECTRICITY AND LIGHTING

#### PART 1 – GENERAL

##### 1.1 DESCRIPTION

- A. The CONTRACTOR shall provide temporary electrical services, and temporary lighting, until Substantial Completion of the Project unless otherwise agreed by OWNER and ENGINEER.
- B. All costs, including the charge for power consumed shall be assumed by the CONTRACTOR. Also provide power for testing and initial start-up of equipment.
- C. Materials and equipment may be new or used, however they shall be in first class, fully serviceable condition and must not create unsafe conditions or violate requirements of applicable codes.
- D. CONTRACTOR shall provide his own extension cords, drop lights, power tools, and other small devices required.
- E. Service is required only for lighting, power tools and similar usages. Electric space heaters and large welding machines are not included herein.
- F. All temporary service required beyond the specified locations shall be the responsibility of the CONTRACTOR requiring such power, who shall furnish his own portable generator or other means.

##### 1.2 POWER SOURCE AND SERVICE REQUIRED

- A. CONTRACTOR shall provide either temporary electric service or a generator will be an acceptable method for providing power to the site.
- B. If the CONTRACTOR chooses to provide temporary electric service originating from Duke Energy, contact Joe Huenefeld at 513-535-6232.
- C. Provide each outlet with circuit breaker protection and comply with ground fault protective requirements of NEC.
- D. Provide power to maintain continuous operation of existing facilities during changeover of electrical equipment.
- E. Provide power for testing and checking equipment.
- F. If OWNER occupies part of facility before final acceptance, cost of electricity for that portion will be shared proportionately.

1.3 INSTALLATION

- A. Install temporary work in a neat orderly manner, and make structurally and electrically sound throughout.
- B. Maintain installation throughout construction period to give continuous service and to provide safe working conditions.
- C. Modify service and rearrange wiring as Work progress requires.
- D. Locate all facilities to avoid interference with hoisting, materials handling, storage, traffic areas, existing operable facilities and work under Contracts.
- E. Assume responsibility for and return to original condition any part of the permanent electrical system which is used for construction purposes.

1.4 TEMPORARY LIGHTING

- A. Provide the following minimum lighting:
  - 1. All Open Areas: 5 foot candles.
  - 2. All Stairs and Shop Areas: 10 foot candles.
  - 3. Operating Areas: One 300 watt lamp per 15 foot on centers.
  - 4. Night Security Light: Provide over area within 50 feet of any portion of construction.

1.5 REMOVAL

- A. Completely remove temporary materials and equipment after permanent installation is in use.
- B. Repair damage caused by the temporary service or its removal and restore to specified or original condition.

PART 2 – PRODUCTS (NOT USED)

PART 3 – EXECUTION (NOT USED)

++END OF SECTION++

## SECTION 01540

### SECURITY

#### PART 1 – GENERAL

##### 1.1 DESCRIPTION

- A. CONTRACTOR shall safely guard all Work, materials, equipment and property from loss, theft, damage and vandalism. CONTRACTOR'S duty to safely guard property shall include the OWNER'S property and other adjacent private property from injury or loss in connection with the performance of the Work.
- B. CONTRACTOR shall employ watchmen as needed to provide the required security and prevent unauthorized entry.
- C. CONTRACTOR shall make no claim against the OWNER for damage resulting from trespass.
- D. CONTRACTOR shall make good all damage to property of OWNER and others arising from failure to provide adequate security.
- E. If existing fencing or barriers are breached or removed for purposes of construction, CONTRACTOR shall provide and maintain temporary security fencing equal to the existing in a manner satisfactory to the ENGINEER and OWNER.
- F. Security measures taken by the CONTRACTOR shall be at least equal to those usually provided by OWNER to protect its existing facilities during normal operation.
- G. Maintain security program throughout construction until OWNER'S acceptance and occupancy precludes need for CONTRACTOR'S security program.

#### PART 2 – PRODUCTS (NOT USED)

#### PART 3 – EXECUTION (NOT USED)

++END OF SECTION++

(This page left blank intentionally)

## SECTION 01541

### PROTECTION OF THE WORK AND PROPERTY

#### PART 1 – GENERAL

##### 1.1 DESCRIPTION

- A. CONTRACTOR shall be responsible for taking all precautions, providing all programs, and taking all actions necessary to protect the Work and all public and private property and facilities from damage as specified in the General Conditions and herein.
- B. In order to prevent damage, injury or loss, CONTRACTOR'S actions shall include, but not be limited to, the following:
  - 1. Store apparatus, materials, supplies, and equipment in an orderly, safe manner that will not unduly interfere with the progress of the Work or the Work of any other CONTRACTOR or utility service company.
  - 2. Provide suitable storage facilities for all materials which are subject to injury by exposure to weather, theft, breakage, or otherwise.
  - 3. Place upon the Work or any part thereof only such loads as are consistent with the safety of that portion of the Work.
  - 4. Clean up frequently all refuse, rubbish, scrap materials, and debris caused by his operations, to the end that at all times the site of the Work shall present a safe, orderly and workmanlike appearance.
  - 5. Provide barricades and guard rails around openings, for scaffolding, for temporary stairs and ramps, around excavations, elevated walkways and other hazardous areas.
- C. CONTRACTOR shall not, except after written consent from proper parties, enter or occupy privately-owned land with men, tools, materials or equipment, except on easements provided herein.
- D. CONTRACTOR shall assume full responsibility for the preservation of all public and private property or facility on or adjacent to the site. If any direct or indirect damage is done by or on account of any act, omission, neglect or misconduct in the execution of the Work by the CONTRACTOR, it shall be restored by the CONTRACTOR, at his expense, to a condition equal to that existing before the damage was done.

1.2 BARRICADES AND WARNING SIGNALS

- A. Where Work is performed on or adjacent to any roadway, right-of-way, or public place, CONTRACTOR shall provide barricades, fences, lights, warning signs, danger signals, watchmen, and shall take other precautionary measures for the protection of persons or property and of the Work. Barricades shall be painted to be visible at night. From sunset to sunrise, CONTRACTOR shall furnish and maintain at least one light at each barricade. Sufficient barricades shall be erected to keep vehicles from being driven on or into Work under construction. CONTRACTOR shall furnish watchmen in sufficient numbers to protect the Work. CONTRACTOR'S responsibility for the maintenance of barricades, signs, lights, and for providing watchmen shall continue until the Project is accepted by OWNER.

1.3 TREE AND PLANT PROTECTION

- A. CONTRACTOR shall protect existing trees, shrubs and plants on or adjacent to the site that are shown or designated to remain in place by the OWNER against unnecessary cutting, breaking or skinning of trunk, branches, bark or roots.
- B. Materials or equipment shall not be stored or parked within the drip line.
- C. Temporary fences or barricades shall be installed to protect trees and plants in areas subject to traffic.
- D. Fires shall not be permitted under or adjacent to trees and plants.
- E. Within the limits of the Work, water trees and plants that are to remain, in order to maintain their health during construction operations.
- F. Cover all exposed roots with burlap that shall be kept continuously wet. Cover all exposed roots with earth as soon as possible. Protect root systems from mechanical damage and damage by erosion, flooding, run-off or noxious materials in solution.
- G. If branches or trunks are damaged, prune branches immediately and protect the cut or damaged areas with emulsified asphalt compounded specifically for horticultural use in a manner approved by the ENGINEER.
- H. All damaged trees and plants that die or suffer permanent injury shall be removed when ordered by the ENGINEER and replaced by a specimen of equal or better quality.
- I. Coordinate Work in this Section with requirements of Sections 02700 and 02800.

## 1.4 PROTECTION OF EXISTING STRUCTURES

### A. Underground Structures:

1. Underground structures are defined to include, but not be limited to, all sewer, water, gas, and other piping, and manholes, chambers, electrical conduits, tunnels and other existing subsurface work located within or adjacent to the limits of the Work.
2. All underground structures known to ENGINEER except water, sewer, electric, and telephone service connections are shown. This information is shown for the assistance of CONTRACTOR in accordance with the best information available, but is not guaranteed to be correct or complete.
3. CONTRACTOR shall explore ahead of his trenching and excavation Work and shall uncover all obstructing underground structures sufficiently to determine their location, to prevent damage to them and to prevent interruption to the services, which such structures provide. If CONTRACTOR damages an underground structure, he shall restore it to original condition at his expense.
4. Necessary changes in the location of the Work may be made by ENGINEER, to avoid unanticipated underground structures.
5. If permanent relocation of an underground structure or other subsurface facility is required and is not otherwise provided for in the Contract Documents, ENGINEER will direct CONTRACTOR in writing to perform the Work, which shall be paid for under the provisions of Article 11 of the General Conditions.
6. See additional requirements on the Drawings.

### B. Surface structures:

1. Surface structures are defined as all existing buildings, structures and other facilities above the ground surface. Included with such structures are their foundations or any extension below the surface. Surface structures include, but are not limited to, buildings, tanks, walls, bridges, roads, dams, channels, open drainage, piping, poles, wires, posts, signs, markers, curbs, walks and all other facilities that are visible above the ground surface.

### C. Protection of Underground and Surface Structures:

1. CONTRACTOR shall sustain in their places and protect from direct or indirect injury all underground and surface structures located within or adjacent to the limits of the Work. Such sustaining and supporting shall be done carefully and as required by the party owning or controlling such structure. Before proceeding with the work of sustaining and supporting

such structure, CONTRACTOR shall satisfy the ENGINEER that the methods and procedures to be used have been approved by the party owning same.

2. CONTRACTOR shall assume all risks attending the presence or proximity of all underground and surface structures within or adjacent to the limits of the Work. CONTRACTOR shall be responsible for all damage and expense for direct or indirect injury caused by his Work to any structure. CONTRACTOR shall repair immediately all damage caused by his work, to the satisfaction of the OWNER of the damaged structure.

D. All other existing surface facilities, including but no limited to, guard rails, posts, guard cables, signs, poles, markers, and curbs which are temporarily removed to facilitate installation of the Work shall be replaced and restored to their original condition at CONTRACTOR'S expense.

#### 1.5 PROTECTION OF INSTALLED PRODUCTS AND LANDSCAPING

A. Provide protection of installed products to prevent damage from subsequent operations. Remove protection facilities when no longer needed, prior to completion of Work.

B. Control traffic to prevent damage to equipment, materials and surfaces.

#### PART 2 – PRODUCTS (NOT USED)

#### PART 3 – EXECUTION (NOT USED)

++END OF SECTION++



## SECTION 01550

### ACCESS ROADS AND PARKING AREAS

#### PART 1 – GENERAL

##### 1.1 DESCRIPTION

- A. CONTRACTOR shall provide all temporary construction roads, walks and parking areas required during construction and for use of emergency vehicles. Temporary roads and parking areas shall be designed and maintained by the CONTRACTOR so as to be fully usable in all weather conditions.
- B. CONTRACTOR shall prevent interference with traffic and the OWNER'S operations on existing roads. He shall indemnify and save harmless the OWNER from any expenses caused by CONTRACTOR'S operations over these roads.
- C. Roadways damaged by CONTRACTOR shall be restored to their original condition by the CONTRACTOR subject to approval of the ENGINEER.
- D. Temporary roads, walks, and parking areas shall be removed by the CONTRACTOR prior to final acceptance and the ground returned to its original condition, unless otherwise required by the Contract Documents or the ENGINEER.

##### 1.2 TRAFFIC CONTROLS

- A. Provide temporary traffic controls at junction of temporary roads with public roads in accordance with Kentucky Transportation Cabinets Specifications, Section 112 – Maintenance and Control of Traffic during Construction.

##### 1.3 DESIGNATED PARKING

- A. No CONTRACTOR employee's personal vehicle shall be allowed to park anywhere other than the areas approved by the OWNER. The CONTRACTOR shall prepare and maintain this area as required.

##### 1.4 MAINTENANCE OF ROADS

- A. CONTRACTOR shall at all times maintain approved access for trucks to loading areas of the construction site and parking facilities. All parking of construction vehicles shall be in approved parking areas.
- B. CONTRACTOR shall sweep all paved roads, daily if necessary, that are utilized in the prosecution of the Work.
- C. CONTRACTOR shall keep the above roads clean and serviceable at all times.
- D. Dust resulting from construction operations shall be controlled by the CONTRACTOR to prevent a nuisance on the site or in adjacent areas.

PART 2 – PRODUCTS (NOT USED)

PART 3 – EXECUTION (NOT USED)

++END OF SECTION++

## SECTION 01560

### ENVIRONMENTAL CONTROLS

#### PART 1 – GENERAL

##### 1.1 DESCRIPTION

- A. Provide and maintain equipment, and temporary construction, as necessary to provide controls over environmental and safety conditions at the construction site and adjacent areas. Remove physical evidence of temporary facilities at completion of Work.
  
- B. Prohibited Construction Activities:
  - 1. Disposing of excess or unsuitable excavated material in wetlands or floodplains, even with the permission of the property OWNER.
  - 2. Locating stockpile storage areas in environmentally sensitive areas.
  - 3. Indiscriminate, arbitrary, or capricious operation of equipment in any stream corridors, any wetlands, any surface waters, or outside the construction limits.
  - 4. Pumping of sediment-laden water from trenches or other excavations directly into any surface waters, any stream corridors, any wetlands, or storm sewers; all such water will be properly filtered or settled to remove silt prior to release.
  - 5. Discharging pollutants such as chemicals, fuels, lubricants, bituminous materials, raw sewage and other harmful waste into or alongside of rivers, streams, impoundments, or into natural or manmade channels leading thereto.
  - 6. Permanent or unspecified alteration of the flow line of any stream.
  - 7. Damaging vegetation outside of the construction area.
  - 8. Disposal of trees, brush, and other debris in any stream corridors, any wetlands, any surface waters, or at unspecified locations.
  - 9. Open burning of project debris without a permit.
  - 10. Discharging injurious silica dust concentrations into the atmosphere resulting from breaking, cutting, chipping, drilling, buffing, grinding, polishing, shaping or surfacing closer than 200 feet to places of residences or commercial, professional, quasi-public or public places of human occupation.

11. Storing construction equipment and vehicles and/or stockpiling construction materials on property, public or private, not previously specified on the plans by the ENGINEER for such purposes.
12. Running well point or pump discharge lines through private property or public property and rights-of-way without the written permission of the property OWNER and the consent of the ENGINEER.
13. Non-compliance with the CONTRACTOR'S, OSHA's, or the OWNER'S safety requirements.

1.2 SAFETY ADVISORY

- A. The CONTRACTOR shall at all times conduct the work safely in order to assure a safe work site. The CONTRACTOR shall be responsible for the safety of the CONTRACTOR'S employees, agents and SUB-CONTRACTORS, OWNER'S personnel and all other personnel or persons at the work site. The CONTRACTOR shall be responsible for the adequacy and safety of all construction methods or procedures and the safe prosecution of the work.
- B. The CONTRACTOR shall be responsible at all times to conduct the work and keep the work site in compliance with federal, state, and local safety Laws and Regulations, including but not limited to Occupational Safety and Health (OSHA) requirements. This includes shaft drilling operations, concrete moving and placement, confined space entry requirements for trench construction, including use of a trench box or other shoring to support trench walls and proper means of exit from an excavation.
- C. The CONTRACTOR shall, prior to actual construction, submit a Site Safety Manual tailored to the project along with the name or names of an authorized person who is a competent person as defined by OSHA (CFR, Title 29 – Labor, Part 1926 – OSHA) responsible for site safety activities. A resume of the qualifications of the competent person must be submitted to the OWNER. This resume shall include such items as: experience, education, special safety and first aid courses completed, safety conferences attended, familiarity with standards and regulations and certifications or registration.
- D. The CONTRACTOR shall have an authorized and competent safety representative as defined above on the work site at frequent and regular intervals, or more often, as conditions require. Failure to have such a person at the site as specified herein constitutes an unsafe practice.
- E. The CONTRACTOR shall be responsible to suspend Work whenever a Work method or procedure or condition at work site is unsafe.
- F. The CONTRACTOR shall submit a written notification to the OWNER of any accident or injury. Such notification shall include the CONTRACTOR'S investigation and what measures are appropriate to avoid such accidents. Payment applications will not be authorized until such notice is provided.

- G. Failure of the CONTRACTOR to comply with any provision of this Specification section or the OWNER'S safety requirements or any federal, state or local safety Laws and Regulations constitute just cause for the OWNER to order suspension of Work.
- H. The CONTRACTOR will conduct Site Safety Audits on a periodic basis to be determined by the OWNER. The audit shall be performed using the Audit Checklist to be provided by the OWNER. The CONTRACTOR'S safety representative will perform the audit with the OWNER'S authorized representative in attendance. A copy of the completed audit checklist shall be furnished to the OWNER.
- I. None of the provisions of the section are intended to, nor shall be construed to, create any duty or responsibility on the OWNER or ENGINEER to provide or enforce safety requirements of the CONTRACTOR. The duty, responsibility, and liability for safety shall remain with the CONTRACTOR.

### 1.3 JOB-SPECIFIC PRECAUTIONS

- A. The CONTRACTOR is advised to consider the job-specific elements of the Work when preparing and executing the safety plan.
- B. The CONTRACTOR shall make its own site investigation and evaluation for job- or site-specific safety concerns in addition to those listed herein.
- C. The following should be considered in preparation of the safety plan specific to the Work governed by this contract. The list does not limit, evaluate, or influence the means and methods of construction.
- D. Job-specific precautions include:
  - 1. Personal protection equipment
  - 2. Control of hazardous energy Lock-Out, Tag-Out (LOTO) procedures
  - 3. Fall prevention and fall protection
  - 4. Worker compensation requirements
  - 5. Housekeeping, Slips Trips and Falls
  - 6. Working within trenches and within excavation support
  - 7. Hazardous communication program employee right to know
  - 8. Maintaining safety in Work Zone.
  - 9. Protection of pedestrians (barricades, signs, sidewalk closures, and temporary walkways).
  - 10. Traffic control and Flagger safety.

11. Construction parking and access.
12. Storage of equipment and materials.
13. Dust control.
14. Movement of equipment and materials.
15. Moving and lifting of materials.
16. Confined space entry (manholes, trenches, sewer connections).
17. Emergency notification & First Aid.
18. Electrical (temporary power and extension cords). Ground fault protection and assured grounding program
19. Sanitation.
20. Fire Protection.
21. Temporary pumping for dewatering.
22. Fire Explosive Prevention Program using Hot Work Permits (obtain before use of sparking or open flame equipment).

- E. The above list is not intended to be an all-inclusive list and the CONTRACTOR is responsible for safety in all areas, whether listed above or not.
- F. CONTRACTOR shall submit to the OWNER, prior to the Pre-Construction meeting, a Site Safety Plan tailored to the project.
- G. In addition, any safety information or documentation required under the law to be filed with any state or federal agency, shall also be supplied to the OWNER. A copy of the Site Safety Plan shall at all times be present at the Work Site.
- H. The OWNER and ENGINEER, prior to the start of work on the project, shall review the Site Safety Plan. Such review shall not constitute approval, but is merely to assure general compliance with the intent of the Specifications.

#### 1.4 AIR POLLUTION AND NOISE CONTROL

- A. CONTRACTOR'S vehicles and equipment shall be such as to minimize noise to the greatest degree practicable. Noise levels shall conform to the latest OSHA standards and in no case will noise levels be permitted which interfere with the work of the OWNER or others.
  1. Construction equipment will be provided with intake silencers and mufflers, as required by safety standards.

2. All construction vehicles should be equipped with proper emissions control equipment.
3. Periodically check equipment and machinery for proper tuning to minimize exhaust emissions and noise.

1.5 DUST CONTROL

- A. CONTRACTOR shall be responsible for controlling objectionable dust caused by his operation of vehicles and equipment, clearing or for any reason whatever. CONTRACTOR shall apply water and calcium chloride or use other methods subject to the ENGINEER'S approval which will keep dust in the air to a minimum. Dust control measures shall be implemented multiple times throughout each working day if necessary.

1.6 PEST AND RODENT CONTROL

- A. Provide rodent and pest control as necessary to prevent infestation of construction or storage area.
  1. Employ methods and use materials which will not adversely affect conditions at the site or on adjoining properties.

1.7 WATER CONTROL

- A. Provide methods to control surface water and water from excavations and structures to prevent damage to the Work, the site, or adjoining properties.
  1. Control fill, grading and ditching to direct water away from excavations, pits, tunnels and other construction areas; and to direct drainage to proper runoff courses so as to prevent any erosion, damage or nuisance.
- B. Provide, operate and maintain equipment and facilities of adequate size to control surface water.
- C. Dispose of drainage water in a manner to prevent flooding, erosion, or other damage to any portion of the site or to adjoining areas and in conformance with all environmental requirements.

1.8 POLLUTION CONTROL

- A. Provide methods, means and facilities required to prevent contamination of soil, water or atmosphere by the discharge of noxious substances from construction operations.
- B. Provide equipment and personnel, perform emergency measures required to contain any spillages, and to remove contaminated soils or liquids.
  1. Excavate and dispose of any contaminated earth offsite, and replace with suitable compacted fill and topsoil.

- C. Take special measures to prevent harmful substances from entering public waters.
  - 1. Prevent disposal of wastes, effluents, chemicals, or other such substances adjacent to streams, or in sanitary or storm sewers.
- D. Provide systems for control of atmospheric pollutants.
  - 1. Prevent toxic concentrations of chemicals.
  - 2. Prevent harmful dispersal of pollutants into the atmosphere.
- E. All CONTRACTOR'S equipment used during construction shall conform to all current federal, state and local laws and regulations.

1.9 SEDIMENT & EROSION CONTROL

- A. This section covers erosion and sediment control during construction and shall include installing and maintaining sediment controls in locations on the project site specified by the OWNER or ENGINEER, and as necessary to prevent the transport of sediments and sediment laden water outside the limits of the work area. These items shall include, but not be limited to silt fence, diversion berms and swales, inlet protection, check dams, silt basins, silt traps, stabilized construction entrances, and vegetative cover.
- B. The CONTRACTOR shall follow the procedures outlined herein to prevent substances from entering all natural drainage course waters as promulgated by the NPDES Stormwater Permit requirements. CONTRACTOR'S efforts to control pollution and sediment and erosion control to public waters shall comply with requirements by the following documents:
  - 1. U.S. EPA – Storm Water Management for Construction Activities, most current edition.
  - 2. Soil Conservation Service – Water Management and Sediment Control for Urbanizing Areas, most current edition.
- C. Plan and execute construction and earth work by methods to control surface drainage from cuts and fills, and from borrow and waste disposal areas, to prevent erosion and sedimentation.
  - 1. Hold the areas of bare soil exposed at one time to a minimum. Seed and straw all areas that will not be worked for thirty days within seven days of stopping Work in that area.
  - 2. Provide temporary control measures such as berms, dikes, and drains.
- D. Construct fills and waste areas using selective placement to eliminate surface silts or delays in filling that will allow for erosion to occur.



- E. Periodically inspect earthwork to detect any evidence of the start of erosion, apply corrective measures as required to control erosion and continuously maintain the controls for the entire length of the project. Erosion and sediment controls shall be removed at the completion of construction, as required by the OWNER.
- F. CONTRACTOR shall properly install silt fence, check dams, diversion berms, silt basins, sediment capturing bags or other sediment and erosion controls along the length of the project in areas designated by the ENGINEER during construction to prevent sediment leaving the site and contain runoff within the work area.
- G. Maintenance: The CONTRACTOR shall maintain new and existing erosion and sediment controls to contain sediment and sediment laden water within the Work area. Deficiencies identified during visual inspection by the OWNER, ENGINEER, or other governing regulatory authority shall be remedied by the CONTRACTOR immediately at no additional cost to the OWNER.
- H. Removal and Disposal: The CONTRACTOR shall remove and dispose of erosion and sediment control measures after completion of construction, as directed by the OWNER.
- I. All sediment and sediment laden water shall be contained within the work area during construction and shall not be discharged directly to any adjacent watercourse. If sediment and erosion controls are not installed and maintained by the CONTRACTOR to the OWNER'S satisfaction, the OWNER may not approve the CONTRACTOR's pay requests or the OWNER may stop Work until controls are properly installed.

PART 2 – PRODUCTS (NOT USED)

PART 3 – EXECUTION (NOT USED)

++END OF SECTION++

(This page left blank intentionally)

## SECTION 01570

### MAINTENANCE AND PROTECTION OF TRAFFIC

#### PART 1 – GENERAL

##### 1.1 DESCRIPTION

- A. OWNER shall obtain necessary permits. CONTRACTOR shall arrange all inspections required by the state and pay all charges. CONTRACTOR shall conform to all applicable Kentucky Transportation Cabinet rules and regulations.
- B. Reference Standards: Comply with the applicable provisions and recommendations, unless otherwise shown or specified.
  - 1. “Standard Specifications for Road and Bridge Construction” of the Kentucky Transportation Cabinet (KYTC), most current edition.
  - 2. All traffic control, including sign, signals, etc., shall conform to AASHTO Manual of Uniform Traffic Control Devices.
- C. When required to cross, obstruct or temporarily close a street or traffic way, CONTRACTOR shall provide and maintain suitable bridges, detours or other approved temporary expedient for the accommodation of traffic. Work may be installed by the open cut method; however, the traffic flow shall be maintained. A minimum of two lanes of traffic shall be kept flowing. Closings shall be for the shortest time practical, and passage shall be restored immediately after completion of backfill and temporary paving or bridging.
- D. CONTRACTOR shall give the required advance notice to the fire and police departments of his proposed operations.
- E. CONTRACTOR shall give reasonable notice to OWNERS or tenants of private property who may be affected by his operations.
- F. CONTRACTOR shall provide signs, signals, barricades, flares, lights, and all other equipment, service and personnel required to regulate and protect all traffic, and warn of hazards. All such work shall conform to requirements of the Kentucky Transportation Cabinet.

##### 1.2 TRAFFIC SIGNALS AND SIGNS

- A. Provide and operate traffic control and directional signals required to direct and maintain an orderly flow of traffic in all areas under CONTRACTOR’S control, or affected by CONTRACTOR’S operations per the Kentucky Transportation Cabinet regulations.

- B. Provide traffic control and directional signs, mounted on barricades or standard post, per Kentucky Transportation Cabinet regulations:
  - 1. At each change of direction of a roadway and at each crossroad.
  - 2. At detours and hazardous areas.
  - 3. At parking areas.
  - 4. Any other areas designated by the Kentucky Transportation Cabinet regulations.

1.3 FLAGMAN

- A. Provide qualified and suitably equipped flagmen when construction operations encroach on traffic lanes, as required for regulation of traffic and in accordance with the requirements of the Kentucky Transportation Cabinet.

1.4 FLARES AND LIGHTS

- A. Provide flares and lights during periods of low visibility as required by the Kentucky Transportation Cabinet.

1.5 PARKING CONTROL

- A. Control all CONTRACTOR related vehicular parking within the limits of the Work to preclude interference with public traffic or parking, access by emergency vehicles, OWNER'S operations, or construction operations.
- B. Monitor parking of all construction and private vehicles:
  - 1. Maintain free vehicular access to and through parking areas.
  - 2. Prohibit parking on or adjacent to access roads, or in non-designated areas.

1.6 HAUL ROUTES

- A. Consult with governing authorities and establish thoroughfares which will be used as haul routes and site access.
- B. Confine construction traffic to designated haul routes.
- C. Provide traffic control at critical areas of haul routes to expedite traffic flow, to minimize interference with normal public traffic.

1.7 SUBMITTALS

- A. CONTRACTOR shall provide the OWNER with Maintenance of Traffic Plan for approval 14 days prior to the closure or partial closure of any streets.

PART 2 – PRODUCTS (NOT USED)

PART 3 – EXECUTION (NOT USED)

++END OF SECTION++

(This page left blank intentionally)

## SECTION 01610

### TRANSPORTATION AND HANDLING PRODUCTS

#### PART 1 – GENERAL

##### 1.1 DESCRIPTION

- A. This Section includes the general requirements for the transportation and handling of products.
- B. CONTRACTOR shall make all arrangements for transportation, delivery and handling of products required for prosecution and completion of the Work.
- C. Shipments of products to CONTRACTOR or SUB-CONTRACTORS shall be delivered to the Site only during regular working hours. Shipments shall be addressed and consigned to the proper party giving name of Project, street number and city. Shipments shall not be delivered to OWNER except where otherwise directed.
- D. If necessary to move stored products during construction, CONTRACTOR shall move or cause to be moved such stored products without any additional compensation.

##### 1.2 PREPARATION FOR SHIPMENT

- A. When practical, factory-assemble products. Match mark or tag separate parts and assemblies to facilitate field assembly. Cover machined and unpainted parts that may be damaged by the elements with a strippable protective coating.
- B. Package products to facilitate handling and protect from damage during shipping, handling, and storage. Mark or tag outside of each package or crate to indicate its purchase order number, bill of lading number, contents by name, OWNER'S contract name and number, CONTRACTOR, equipment number, and approximate weight. Include complete packing lists and bills of materials with each shipment.
- C. Protect products from exposure to the elements and keep thoroughly dry and dust free at all times. Protect painted surfaces against impact, abrasion, discoloration, or other damage. Grease or oil all bearings and similar items.
- D. Do not have products shipped until:
  - 1. Related Shop Drawings have been approved by OWNER.
  - 2. Related factory test results, required in the individual Specification Sections, have been reviewed and accepted by OWNER; and
  - 3. Required storage facilities have been provided.

### 1.3 DELIVERY

- A. Arrange deliveries of products in accord with progress schedules and in ample time to facilitate inspection prior to installation.
- B. Coordinate deliveries to avoid conflict with Work and conditions at Site, and to accommodate the following:
  - 1. Work of other CONTRACTORS, or OWNER.
  - 2. Limitations of storage space.
  - 3. Availability of equipment and personnel for handling products.
  - 4. OWNER'S use of premises.
- C. Have products delivered to Site in manufacturer's original, unopened, labeled containers.
- D. Clearly mark partial deliveries of component parts of equipment to identify the equipment, to permit easy accumulation of parts and to facilitate assembly.
- E. Immediately on delivery, inspect shipment to assure:
  - 1. Product complies with requirements of Contract Documents and reviewed submittals.
  - 2. Quantities are correct.
  - 3. Containers and packages are intact, labels are legible.
  - 4. Products are properly protected and undamaged.
- F. Promptly remove damaged products from the Site and expedite delivery of new undamaged products, and remedy incomplete or lost products to provide that specified, so as not to delay progress of the Work.

### 1.4 PRODUCT HANDLING

- A. Provide equipment and personnel necessary to handle products, including those provided by OWNER, by methods to prevent soiling or damage to products or packaging.
- B. Provide additional protection during handling as necessary to prevent scraping, marring or otherwise damaging products or surrounding surfaces.
- C. Handle products by methods to prevent bending or overstressing.
- D. Lift heavy components only at designated lifting points.



- E. Handle products in a safe manner and as recommended by manufacturer to prevent damage. Do not drop, roll or skid products off delivery vehicles. Hand carry or use suitable materials handling equipment.

PART 2 – PRODUCTS (NOT USED)

PART 3 – EXECUTION (NOT USED)

++END OF SECTION++

(This page left blank intentionally)

## SECTION 01611

### STORAGE AND PROTECTION OF PRODUCTS

#### PART 1 – GENERAL

##### 1.1 DESCRIPTION

- A. This Section includes the general requirements for the storage and protection of products.

##### 1.2 STORAGE

- A. Store and protect products, with labels intact and legible, in accordance with manufacturer's recommendations and requirements of Specifications.
- B. CONTRACTOR shall make all arrangements and provisions necessary for the storage of products. All excavated materials, construction equipment, and materials and equipment to be incorporated into the Work shall be placed so as not to injure any part of the Work or existing facilities, and so that free access can be had at all times to all parts of the Work and to all public utility installations in the vicinity of the Work. Products shall be kept neatly and compactly stored in locations that will cause a minimum of inconvenience to other CONTRACTORS, public travel, adjoining OWNERS, tenants and occupants. Arrange storage in a manner to provide easy access for inspection.
- C. Areas available on the Site for storage of products shall be as shown or approved by the OWNER.
- D. Products which are to become the property of the OWNER shall be stored to facilitate their inspection and insure preservation of the quality and fitness of the Work, including proper protection against damage by freezing and moisture.
- E. Lawns, grass plots or other private property shall not be used for storage purposes without written permission of the OWNER or other person in possession or control of such premises.
- F. CONTRACTOR shall be fully responsible for loss or damage including theft, to stored products.
- G. Do not open manufacturers' containers until time of installation unless recommended by the manufacturer or otherwise specified.
- H. Do not store products in the structures under construction unless approved in writing by the OWNER.

### 1.3 UNCOVERED STORAGE

- A. The following types of materials may be stored outdoors without cover:
  - 1. Masonry units.
  - 2. Reinforcing steel.
  - 3. Structural steel.
  - 4. Piping, except PVC.
  - 5. Precast concrete items.
  - 6. Castings.
  - 7. Handrailing.
- B. Store the above products on wood blocking or skids so there is no contact with the ground.

### 1.4 COVERED STORAGE

- A. The following types of products may be stored outdoors if covered with material impervious to water:
  - 1. Rough lumber.
  - 2. PVC piping.
- B. Tie down covers with rope and slope to prevent accumulation of water on covers.
- C. Store the above products on wood blocking or skids.
- D. Store loose granular materials, covered with materials impervious to water, in a well-drained area or solid surfaces to prevent mixing with foreign matter.

### 1.5 FULLY PROTECTED STORAGE

- A. Store all products not named above in buildings or trailers which have a concrete or wooden floor, a roof, and fully closed walls on all sides.
- B. Provide heated storage space for products which could be damaged by freezing.
- C. Protect mechanical and electrical equipment from being contaminated by dust, dirt and moisture.
- D. Maintain humidity at levels recommended by manufacturers for electrical and electronic equipment.

1.6 PANEL AND INSTRUMENTATION STORAGE

- A. All panels, microprocessor based equipment and all other devices subject to damage or useful life decrease because of temperatures below 40°F and above 120°F, relative humidity above 90 percent, or exposure to rain shall not be stored on site.
- B. Storage shall be in an insured climate controlled warehouse.
- C. All costs for the storage shall be included in the Contract Price. Any panel or device which has been damaged by any cause or for which the storage temperatures or humidity range has been exceeded shall be replaced at no cost to the OWNER and shall not be cause for a delay in Contract completion.

1.7 RECORDS

- A. Keep running account of products in storage to facilitate preparation of progress payments if Agreement provides for payment for products delivered, but not installed in the Work.

PART 2 – PRODUCTS (NOT USED)

PART 3 – EXECUTION (NOT USED)

++END OF SECTION++

(This page left blank intentionally)

## SECTION 01710

### CLEANING

#### PART 1 – GENERAL

##### 1.1 REQUIREMENTS OF REGULATORY AGENCIES

- A. Conduct cleaning and waste-removal operations to comply with local laws and ordinances and Federal and local environmental and anti-pollution regulations.

##### 1.2 PROGRESS CLEANING

- A. General: Clean the Site, Work areas and other areas CONTRACTOR is permitted to occupy by Laws and Regulations at least weekly. Dispose of materials lawfully according to Laws and Regulations:
  - 1. Comply with requirements in NFPA 241, Standard for Safeguarding Construction, Alteration and Demolition Operations, for removal of combustible waste materials and debris.
  - 2. Do not hold other materials more than 7 days during normal weather or 3 days if the temperature is expected to rise above 80 F.
  - 3. Provide suitable containers for storage of waste materials and debris.
  - 4. Containerize hazardous and unsanitary waste materials separately from other waste. Mark containers appropriately.
- B. Project:
  - 1. Maintain Project free of waste materials and debris.
  - 2. Keep exterior dust-generating areas wetted down.
  - 3. At least weekly, brush sweep all existing site roadways affected by the Work.
- C. Work Areas: Clean areas where Work is in progress to the level of cleanliness necessary for proper execution of the Work.
  - 1. Remove liquid spills promptly.
  - 2. Where dust would impair proper execution of the Work, broom-clean or vacuum the entire Work area, as appropriate.

- D. Installed Work: Keep installed Work clean. Clean installed surfaces according to written instructions of manufacturer or fabricator of product installed, using only cleaning materials specifically recommended. If specific cleaning materials are not recommended, use cleaning materials that are not hazardous to health or property and that will not damage exposed surfaces.
- E. Concealed Spaces: Remove debris from concealed spaces before enclosing the space.
- F. Exposed Surfaces: Clean exposed surfaces and protect as necessary to ensure freedom from damage and deterioration at time of Substantial Completion.
- G. Cutting and Patching: Clean areas and spaces where cutting and patching are performed. Completely remove paint, mortar, oils, putty, and similar materials.
  - 1. Thoroughly clean piping, conduit, and similar features before applying paint or other finishing materials. Restore damaged pipe covering to its original condition.
- H. Waste Disposal: Burying or burning waste materials on the Site will not be permitted. Washing waste materials down sewers or into waterways will not be permitted.
- I. During handling and installation, clean and protect construction in progress and adjoining materials already in place. Apply protective covering where required to ensure protection from damage or deterioration at Substantial Completion.
- J. Clean and provide maintenance on completed construction as frequently as necessary through the remainder of the construction period. Adjust and lubricate operable components to ensure operability without damaging effects.
- K. See additional requirements in section 01560 Environmental Controls.

### 1.3 FINAL CLEANING

- A. General: Provide final cleaning.
  - 1. Complete the following cleaning and waste-removal operations before requesting inspection for certification of Substantial Completion for entire Project or for a portion of Project:
    - a. Clean and remove from the Project rubbish, waste material, litter, and other foreign substances.
    - b. Sweep paved areas broom clean. Remove petrochemical spills, stains and other foreign deposits.
    - c. Hose clean sidewalks and loading areas.



- d. Rake grounds that are neither planted nor paved to a smooth, even-textured surface.
- e. Leave water courses, gutters, and ditches open and clean.
- f. Remove snow and ice to provide safe access to buildings.
- g. Remove debris and surface dust from limited access spaces, including roofs, plenums, shafts, trenches, equipment vaults, manholes, and similar spaces.
- h. Remove tags and labels that are not permanent.
- i. Touch up and otherwise repair chipped, scratched, dented or otherwise marred surfaces to specified finish and match adjacent surfaces.
  - (1) Do not paint over "UL" and similar labels, including mechanical and electrical nameplates.
- j. Wipe surfaces of mechanical and electrical equipment, and similar equipment. Remove excess lubrication, paint and mortar droppings, and other foreign substances.
- k. Maintain the cleaning until OWNER occupies the Project or portion thereof.
- l. Leave Project clean and in a neat and orderly condition satisfactory to OWNER.

PART 2 – PRODUCTS (NOT USED)

PART 3 – EXECUTION (NOT USED)

++END OF SECTION++

(This page left blank intentionally)

## SECTION 01720

### RECORD DOCUMENTS

#### PART 1 - GENERAL

##### 1.1 DESCRIPTION

- A. CONTRACTOR shall maintain and provide the OWNER with record documents as specified below.
- B. Maintenance of Documents:
  - 1. Maintain in CONTRACTOR'S field office or other secure area onsite in clean, dry, legible condition complete sets of the following: Drawings, Specifications, Addenda, approved Shop Drawings, Samples, photographs, Change Orders, other modifications of Contract Documents, test records, survey data, Field Orders, and all other documents pertinent to CONTRACTOR'S Work.
  - 2. Provide files and racks for proper storage and easy access. File in accordance with filing format of Construction Specification Institute (CSI), unless otherwise approved by OWNER.
  - 3. Make documents available onsite at all times for inspection by OWNER. Failure to keep record documents onsite and up-to-date may be grounds for the OWNER to not approval the CONTRACTOR'S pay requests.
  - 4. Record documents shall not be used for any other purpose and shall not be removed from the CONTRACTOR'S office without OWNER'S approval.
- C. Marking System: Provide colored pencils or felt tipped pens for marking changes, revisions, additions and deletions, to the record set of Drawings. Use following color code unless otherwise approved by the OWNER:
  - 1. Process and Mechanical: Red
  - 2. Yard Piping: Red
  - 3. Architectural: Blue
  - 4. Structural: Purple
  - 5. Plumbing: Brown
  - 6. HVAC: Green
  - 7. Other Printed Notations: Black

D. Recording:

1. Label each document "PROJECT RECORD" in 2-inch high printed letters.
2. Keep record documents current.
3. Do not permanently conceal any Work until required information has been recorded.
4. Drawings: Legibly mark to record actual construction including:
  - a. Depths of various elements of foundation in relation to datum.
  - b. Horizontal and vertical location of underground utilities and appurtenances referenced to permanent surface improvements.
  - c. Location of internal utilities and appurtenances concealed in construction referenced to visible and accessible features of structure.
  - d. Field changes of dimensions and details.
  - e. Changes made by Change Order or Field Order.
  - f. Details not on original Drawings.
5. Specifications and Addenda: Legibly mark up each Section to record:
  - a. Manufacturer, trade name, catalog number, and supplier of each product and item of equipment actually installed.
  - b. Changes made by Change Order or Field Order.
  - c. Other matters not originally specified.

E. Submittal:

1. Upon Substantial Completion of the Work, deliver record documents to OWNER. Final payment will not be made until satisfactory record documents are received by OWNER.
2. Accompany submittal with transmittal letter containing:
  - a. Date.
  - b. Project title and number.
  - c. CONTRACTOR'S name and address.
  - d. Title and number of each record document.

- e. Certification that each document as submitted is complete and accurate.
- f. Signature of CONTRACTOR, or his authorized representative.

PART 2 – PRODUCTS (NOT USED)

PART 3 – EXECUTION (NOT USED)

++END OF SECTION++

(This page left blank intentionally)

**DIVISION 2 - SITEWORK**

(This page left blank intentionally)



## SECTION 02100

### CLEARING & GRUBBING

#### PART 1 – GENERAL

##### 1.1 DESCRIPTION

- A. This work shall consist of clearing, grubbing, removing, and disposing of all vegetation, buildings, pavements and foundations not removed by others, including all curbs, medians, pavements, drainage structures, etc. noted for demolition on the project plans, and debris which is within designated limits inside the Project construction area, except such objects as are designated to remain or to be removed in accordance with the project plans or other Sections of these Specifications. This work shall also include the Preservation from injury or defacement of all vegetation and objects to remain.

#### PART 2 - PRODUCTS (NOT USED)

#### PART 3 – EXECUTION

##### 3.1 CLEARING AND GRUBBING

- A. All work pertaining to this section shall be in accordance with the Kentucky Standard Specifications for Road and Bridge Construction, most current edition, unless noted otherwise on the plans or these specifications.
- B. The ENGINEER will designate all trees, shrubs, plants, and other items to remain. Paint or ribbon required for cut or scarred surfaces of trees or shrubs selected for retention shall be an approved asphaltum base paint prepared especially for tree surgery.
- C. The entire construction area shall be cleared of all weeds, brush, briars, bushes, trees, stumps, and other protruding obstructions not designated to remain, except within areas the ENGINEER may designate to remain undisturbed. In addition, all bushes, trees, roots and stumps within the line of slope stakes shall be grubbed. In addition, all topsoil, surficial vegetation containing the heavy root system, stumps and debris shall be removed from all proposed cut, fill and at-grade areas.
- D. Stockpile removed topsoil for use in landscape areas and completed embankment slopes. Dispose of unsuitable topsoil in OWNER'S spoil area.
- E. Burning will not be permitted.
- F. No blasting is permitted.
- G. Transport unacceptable excavated material, trees, trash and debris off OWNER'S property and dispose of legally.

- H. Removing Trees or Stumps: This work shall include cutting trees, removing their stumps and roots from the ground, and disposing of the material; and the removal of existing stumps and their roots and disposing of the material.

3.2 SURVEY MONUMENTATION

- A. Any and all survey monumentation encountered and removed during the course of construction must be put back in its original location at the completion of construction by a Registered Surveyor licensed in the State of Kentucky.

++ END OF SECTION ++

## SECTION 02200

### EARTHWORK, GRADING AND BACKFILLING

#### PART 1 – GENERAL

##### 1.1 DESCRIPTION

###### A. Scope

1. CONTRACTOR shall provide all labor, materials, equipment and incidentals required to perform all clearing, excavating, filling, grading, disposal of earth materials as shown, specified, and required for construction of structures, manholes, vaults, conduits, pipelines, roads, and other facilities required to complete the Work in every respect.
2. All necessary preparation of subgrade for slabs, pavements, etc. is included.
3. All temporary means needed to prevent discharge of sediment to water courses from dewatering systems or erosion is included.
4. No classification of excavated materials will be made. Excavation includes all materials regardless of type, character, composition, moisture, or condition thereof.

##### 1.2 QUALITY ASSURANCE

###### A. Construction Review Services

1. CONTRACTOR is required to use a KYTC pre-qualified Geotechnical Engineer for all testing and laboratory services required throughout construction as noted in Section 01410.
2. The Geotechnical Engineer will distribute the test reports to OWNER, ENGINEER and CONTRACTOR for General Construction.

###### B. Reference Standards: Comply with applicable provisions and recommendations of the following except as otherwise shown or specified.

1. KM 64-519, Particle Size Analysis of Soils.
2. KM 64-511, Moisture – Density Relations of Soils (Standard Proctor Density).
3. AASHTO T191, Standard Method of Test for Density of Soil In-Place by the Sand-Cone Method.

4. AASHTO T310, Standard Specification for In-Place Density and Moisture Content of Soil and Soil-Aggregate by Nuclear Methods (Shallow Depth).
5. ASTM D4253, Standard Test Method for Maximum Index Density and Unit Weight of Soils Using a Vibratory Table.
6. ASTM D4254, Standard Test Method for Minimum Index Density and Unit Weight of Soils and Calculation of Relative Density.
7. Kentucky Department of Highways (KDOH), Standard Specifications for Road and Bridge Construction, most current edition.
8. OSHA Standard, Title 29, Code of Federal Regulations, Part 1926, Section 650 (Subpart P – Excavations).

### 1.3 EARTHWORK PRE-CONSTRUCTION MEETING

- A. A Pre-Construction Meeting shall be scheduled by the CONTRACTOR and be held at the site with the OWNER'S representative, CONTRACTOR, the Geotechnical ENGINEER and any other interested parties to review the scope and schedule of the proposed earthwork. At this meeting the CONTRACTOR shall inform the group of erosion control measures to be utilized and types of equipment to be used.

## PART 2 - PRODUCTS (NOT USED)

### PART 3 – EXECUTION

#### 3.1 GENERAL

- A. All work pertaining to this section shall be in accordance with the Kentucky Standard Specifications for Road and Bridge Construction, most current edition, unless noted otherwise on the plans or these specifications.

#### 3.2 GRADING

- A. This term shall consist of all grading above or below subgrade elevations of whatever nature required to bring the construction areas to proper subgrade elevations including necessary excavation for pavements, curb, gutter, sidewalk, construction of embankments, excavation and proper sloping of all cuts, and other work incidental thereto.

#### 3.3 CONSTRUCTION OF EMBANKMENT

- A. All surface vegetation, heavy root systems, topsoil, and low-density near-surface soils shall be removed from the area upon which the embankment is to be constructed. The vegetation and heavy root systems shall be wasted. The clean, low-density, near-surface soil can be used in construction of embankment. All

topsoil materials shall be stockpiled and re-spread across scarified areas after the scarified areas have been brought to within inches of finished grade.

- B. Embankments shall be constructed of approved soils to approximate subgrade elevation in shallow level layers, 6 to 8 inches, in loose thickness, within two (2) percent of optimum moisture content, compacted with an appropriate type of compaction equipment to a density not less than 98 percent of maximum dry density, as determined by the Standard Proctor Moisture density test (KM 64-511) beneath roadway and curb/sidewalk areas and to a density not less than 95 percent of same maximum dry density beneath areas outside of the roadway and curb/sidewalk areas. Embankment fill placed over sloping original ground shall be compacted on level benches cut into the sloping original ground, per details in project plans.

### 3.4 PIPE BEDDING AND PIPE ZONE FILL

- A. All pipe bedding and pipe zone fill shall be granular fill in accordance with the project plans and the Kentucky Standard Specifications for Road and Bridge Construction, most current edition.

### 3.5 BACKFILL

- A. Utility trench backfill beneath the pavement, curb and sidewalk areas is to consist of flowable fill placed up to the top of the clay subgrade. Outside of pavement, curb, and sidewalk areas, utility backfill materials shall consist of approved clayey soils or granular soils. Under no conditions shall backfill be flushed to obtain compaction.

### 3.6 SUBGRADE

- A. Any soft or yielding areas resulting from high moisture contents that are encountered at the time of construction shall be scarified, aerated and dried to reduce the moisture content nearer to optimum moisture content, then re-compacted to the specified density.
- B. The subgrade shall be shaped to plan elevation and cross section. Immediately prior to placing the concrete, asphalt, or the granular base materials, the subgrade shall be checked for conformity with the cross section shown on the plans by means of an approved template on the side forms. If necessary, the materials shall be removed or added as required to bring all portions of the subgrade to correct elevations. The subgrade shall be thoroughly compacted and again checked with the template. Concrete, asphalt, or granular base materials shall not be placed on any parts of the subgrade which have not been checked for correct elevation. The subgrade shall be clean of loose or soft material and shall be moistened immediately prior to placing concrete or asphalt. Prior to placing the concrete, asphalt, or granular base material, the CONTRACTOR shall proofroll the compacted subgrade with a piece of equipment, preferably a loaded single axle truck. The ENGINEER shall observe the proof-rolling for consistency. Areas which are subject to pumping or rutting shall be reworked and re-compacted as described above. Undercuts shall only be made when directed by the Project Geotechnical Engineer. Granular base materials shall be placed

immediately prior to the placement of overlying concrete or asphalt to help prevent water from ponding in the granular base and on the prepared subgrade.

3.7 DENSE GRADED AGGREGATE (DGA) BASE

- A. All DGA Base shall be in accordance with Section 302 of the Kentucky Standard Specifications for Road and Bridge Construction, most current edition, unless noted otherwise on the plans or in these specifications.

3.8 EQUIPMENT FOR COMPACTION OF BACKFILL, EMBANKMENT, and SUBGRADE

- A. Any compaction equipment capable of producing the required embankment and subgrade densities, without lamination, will be permitted. Clayey type soils shall be compacted with kneading type compaction equipment, such as a sheepsfoot roller. Cohesionless soils shall be compacted with vibratory type equipment, such as a vibrating plate or roller. All compaction equipment shall be in good condition and shall be operated efficiently to assure uniform compaction.

3.9 EQUIPMENT OPERATED ON STREETS

- A. The CONTRACTOR shall be permitted to operate only pneumatic tired equipment over any paved street surfaces and shall be responsible for correcting any damage to street surfaces resulting from the CONTRACTOR'S operation. Paved street adjacent to new development shall have all loose soil or mud removed at the end of each days work.

3.10 UTILITIES

- A. Special precautions shall be taken by the CONTRACTOR to avoid damage to existing overhead and underground utilities. Before proceeding with the work the CONTRACTOR shall confer with all public or private companies, agencies or departments that own or operate utilities in the vicinity of the construction work. The CONTRACTOR shall be diligent in his efforts to use every possible means to locate existing utilities.

++ END OF SECTION ++

## SECTION 02225

### ROCK REMOVAL

#### PART 1 – GENERAL

##### 1.1 WORK INCLUDED

- A. The CONTRACTOR shall excavate rock, if encountered, as required to perform the required work, and shall dispose of the excavated material, and shall furnish acceptable material for backfill in place of the excavated rock.
- B. No blasting will be allowed in this project.
- C. In general, rock in pipe trenches shall be excavated so as to be not less than 6 inches below the invert of the pipe after it has been laid.
- D. No additional payment will be made for rock excavation.

##### 1.2 DEFINITIONS

- A. Rock: A naturally occurring hard inorganic material that is in-situ. Rock may be either of sedimentary, igneous, or metamorphic origin, and is solid, bedded, jointed or fractured, and cannot be removed without ram hammering or systematic drilling and blasting; and boulders, masonry or concrete, except pavement, exceeding 1 cubic yard volume.

#### PART 2 – PRODUCTS (NOT USED)

#### PART 3 – EXECUTION

##### 3.1 ROCK REMOVAL – MECHANICAL METHOD

- A. Excavate and remove rock by the mechanical method. Drill holes and utilize mechanical impact to fracture rock.
- B. In utility trenches, excavate 6 inches below invert elevation of pipe and 24 inches wider than pipe diameter.
- C. Stockpile excavated materials and reuse select materials for site landscaping. Remove and dispose of excess materials offsite at approved location.

##### 3.2 PAYMENT

Rock excavation shall be bid incidental to the Work and will not be paid for separately.

++ END SECTION ++

(This page left blank intentionally)



## SECTION 02300

### SLOPE PROTECTION AND EROSION CONTROL

#### PART 1-GENERAL

##### 1.1 WORK INCLUDED

- A. The CONTRACTOR shall use the erosion control plan provided by the ENGINEER as a guideline for the placement and types of erosion control structures to be used. If no plan is provided by the ENGINEER or additional erosion control structures are necessary, CONTRACTOR shall conform to the standards as written in "Kentucky Best Management Practices for Construction Activities," prepared by Department of Conservation and the Division of Water, Natural Resources, and Environmental Protection Cabinet and all other local specifications. The CONTRACTOR shall be responsible for periodic maintenance inspections and perform preventative maintenance as necessary on all erosion control measures after each rain event or at a minimum of once per week. The CONTRACTOR shall maintain a log of inspection activities.
- B. The CONTRACTOR shall do all work and take all measures necessary to control soil erosion resulting from construction operations, shall prevent the flow of sediment from the construction site, and shall contain construction materials (including excavation and backfill) within a protected working area so as to prevent damage to adjacent property.
- C. The CONTRACTOR shall not employ any construction method that violates a rule, regulation, guideline or procedure established by Federal, State or local agencies having jurisdiction over the environmental effects of construction. The CONTRACTOR shall be responsible for obtaining all associated permits.
- D. Pollutants such as chemicals, fuels, lubricants, bitumen, raw sewage and other harmful waste shall not be discharged into or alongside of any body of water or into natural or man-made channels leading thereto.
- E. All work shall be in accordance with the Erosion and Sediment Control Plan.
- F. Erosion Control shall meet the requirements of the most current edition of the Kentucky Department of Highways Standard Specifications for Road and Bridge Construction.

PART 2 - PRODUCTS

2.1 MATERIALS

A. Temporary Slope Protection and Erosion Control: Straw mulch shall be reasonably clean and free of noxious weeds and deleterious materials. Filter fabric for sediment traps shall be of suitable materials acceptable to the ENGINEER.

B. Silt Fence Materials

1. Fence Posts --The length shall be a minimum of 32 in. long. Wood posts will be 2-by-2-in. hardwood of sound quality. The maximum spacing between posts shall be 6 ft. Posts shall be driven at least 12 inches into the ground.

2. Reinforced Silt Fence --Posts shall be a minimum 1.33 lb/linear foot steel posts driven at least 12 inches into the ground. The maximum spacing between posts shall be 10 ft. Wire mesh support shall be used and fastened to the upstream side of the posts, consisting of 6-in. by 6-in. 14 gauge wire mesh. The wire mesh shall be extended at least 6 inches in the trench.

3. Silt Fence Fabric (see chart below):

<b>Fabric Properties</b>	<b>Values</b>
Grab Tensile Strength	50 lbs minimum
Mullen Burst Strength	190 psi minimum
Slurry Flow Rate	5 gal./min. f2 maximum
Ultraviolet Radiation Stability	90% Minimum

PART 3 -EXECUTION

3.1 METHODS OF CONSTRUCTION

A. The CONTRACTOR shall use any of the acceptable methods necessary to control soil erosion and prevent the flow of sediment to the maximum extent possible. These methods shall include, but not be limited to, the use of water diversion structures, diversion ditches and settling basins.

B. Construction operations shall be restricted to the areas of work indicated on the Drawings and to the area which must be entered for the construction of temporary or permanent facilities. The ENGINEER has the authority to limit the surface area

of erodible earth material exposed by clearing and grubbing, excavation, borrow and fill operations and to direct the CONTRACTOR to provide immediate permanent or temporary pollution control measures to prevent contamination of wetlands and adjacent watercourses. Such work may involve the construction of temporary berms, dikes, dams, sediment basins, slope drains, and use of temporary mulches, mats, or other control devices or methods as necessary to control erosion.

- C. Excavated soil material shall not be placed adjacent to wetlands or watercourses in a manner that will cause it to be washed away by high water or runoff. Earth berms or diversions shall be constructed to intercept and divert runoff water away from critical areas. Diversion outlets shall be stable or shall be stabilized by means acceptable to the ENGINEER. If for any reason construction materials are washed away during the course of construction, the CONTRACTOR shall remove those materials from the fouled areas as directed by the ENGINEER.
- D. For work within easements, all materials used in construction such as excavation, backfill, roadway, and pipe bedding and equipment shall be kept within the limits of the easements.
- E. The CONTRACTOR shall not pump silt-laden water from trenches or other excavations into wetlands, or adjacent watercourses. Instead, silt-laden water from excavations shall be discharged within areas surrounded by baled hay or into sediment traps to ensure that only sediment-free water is returned to the watercourses. Damage to vegetation by excessive watering or silt accumulation in the discharge area shall be avoided.
- F. Prohibited construction procedures include, but are not limited to, the following:
  - 1. Dumping of spoil material into any streams, wetlands, surface waters or unspecified locations.
  - 2. Indiscriminate, arbitrary, or capricious operation of equipment in wetlands or surface waters.
  - 3. Pumping of silt-laden water from trenches or excavations into surface waters or wetlands.
  - 4. Damaging vegetation adjacent to or outside of the construction area limits.
  - 5. Disposal of trees, brush, debris, paints, chemicals, asphalt products, concrete curing compounds, fuels, lubricants, insecticides, washwater from concrete trucks or hydroseeders, or any other pollutant in wetlands, surface waters, or unspecified locations.
  - 6. Permanent or unauthorized alteration of the flow line of any stream.
  - 7. Open burning of debris from the construction work.

- G. Any temporary working roadways required shall be clean fill approved by the ENGINEER. In the event fill is used, the CONTRACTOR shall take every precaution to prevent the fill from mixing with native materials of the site. All such foreign fill materials shall be removed from the site following construction.

### 3.2 EROSION CHECKS

- A. The CONTRACTOR shall furnish and install rock silt barriers and filter fabric checks in all locations indicated on the Drawings, surrounding the base of all deposits of stored excavated material outside of the disturbed area, and where indicated by the ENGINEER. Checks, where indicated on the Drawings, shall be installed immediately after the site is cleared and before trench excavation is begun at the location indicated. Checks located around stored material shall be located approximately 6 feet from that material.

- 1. Rock Barriers: Temporary rock silt barriers shall be used where indicated on the drawings. They may be used in lieu of fabricated silt fence on areas where silt fence posts cannot be installed due to bed rock. Rock barriers shall be installed to a minimum height of 2 feet and shall be placed to prevent bypassing around the ends of the barrier. Shot rock from on-site construction may be used. A mixture of rock sizes shall be used to prevent short-circuiting of water through the barrier.
- 2. Silt Fence:
  - a. Silt fence shall be constructed before up slope land disturbance begins.
  - b. All silt fences shall be placed as close to the contour as possible so that water will not concentrate at low points in the fence and so that small swales or depressions which may carry small concentrated flows to the silt fence are dissipated along its length.
  - c. To prevent water pounded by the silt fence from flowing around the ends, each end shall be constructed up slope so that the ends are at a higher elevation.
  - d. Where possible, silt fence shall be placed on the flattest area available.
  - e. Where possible, vegetation shall be preserved for 5 ft. (or as much as possible) up slope from the silt fence. If vegetation is removed, it shall be reestablished within 7 days from the installation of the silt fence.
  - f. The height of the silt fence shall be a minimum of 18 in. above the original ground surface.

- g. The silt fence shall be placed in a trench cut a minimum of 6 in. deep. The trench shall be cut with a trencher, cable laying machine, or other suitable device which will ensure an adequately uniform trench depth.
- h. The silt fence shall be placed with the stakes on the downslope side of the geotextile and so that 8 in. of cloth are below the ground surface. Excess material shall lay on the bottom of the 6-in.-deep trench. The trench shall be backfilled and compacted.
- i. Seams between sections of silt fence shall be overlapped with the end stakes of each section wrapped together before driving into the ground.
- j. Maintenance--Silt fence shall allow runoff to pass only as diffuse flow through the geotextile. If runoff overtops the silt fence, flows under or around the ends, or in any other way becomes a concentrated flow, one of the following shall be performed, as appropriate: 1) the layout of the silt fence shall be changed, 2) Accumulated sediment shall be removed, or 3) Other practices shall be installed.

3. Inlet Protection in Swales, Ditch Lines or Yard Inlets

- a. Inlet protection shall be constructed either before up slope land disturbance begins or before the storm drain becomes operational.
- b. The earth around the inlet shall be excavated completely to a depth at least 18 in.
- c. The wooden frame shall be constructed of 2-by-4-in. construction-grade lumber. The 2-by-4-in. posts shall be driven 1 ft. into the ground at four corners of the inlet and the top portion of 2-by-4-in. frame assembled using the overlap joint shown. The top of the frame shall be at least 6-in. below adjacent roads if ponded water would pose a safety hazard to traffic.
- d. Wire mesh shall be of sufficient strength to support fabric with water fully impounded against it. It shall be stretched tightly around the frame and fastened securely to the frame.
- e. Geotextile shall be resistant to sunlight. It shall be stretched tightly around the frame and fastened securely. It shall extend from the top of the frame to 18 in. below the inlet notch elevation. The geotextile shall overlap across one side of the inlet so the ends of the cloth are not fastened to the same post.
- f. Backfill shall be placed around the inlet in compacted 6-in. layers until the earth is even with notch elevation on ends and top elevation on sides.

- g. A compacted earth dike or a check dam shall be constructed in the ditch line below the inlet if the inlet is not in a depression and if runoff bypassing the inlet will not flow to a settling pond. The top of earth dikes shall be at least 6 in. higher than the top of the frame.
- B. The erosion check installations should be inspected on a weekly basis and after every runoff event. Accumulated sediments shall be removed when uniform accumulations reach 1/3 the aboveground height of the barriers.

++ END OF SECTION ++

SECTION 02400

BITUMINOUS CONCRETE PAVEMENT

PART 1 – GENERAL

1.1 DESCRIPTION

- A. All materials and construction methods are to be in accordance with the Kentucky Standard Specifications for Road and Bridge Construction, most current edition (and the most recent version of the Supplemental Specifications), unless otherwise noted on the project plans or these specifications.
- B. CONTRACTOR shall submit all haul tickets for bituminous concrete with each payment application.

PART 2 – PRODUCTS (NOT USED)

PART 3 – EXECUTION (NOT USED)

++ END OF SECTION ++

(This page left blank intentionally)



## SECTION 02410

### FULL-DEPTH RECLAMATION (FDR)

#### PART 1 - GENERAL

##### 1.1 DESCRIPTION

- A. Full-depth reclamation (FDR) with cement shall consist of pulverizing and mixing existing asphalt pavement and base course material with portland cement, soil and water to produce a dense, hard, cement- treated base. It shall be proportioned, mixed, placed, compacted, and cured in accordance with Section 208 of the Kentucky Standard Specifications, current edition, unless otherwise noted. Additionally, it shall conform to the lines, grades, thicknesses, and typical cross sections shown in the plans.

#### PART 2 – MATERIALS AND EQUIPMENT

##### 2.1 GENERAL

- A. Refer to Section 208.02 of the Kentucky Standard Specifications, current edition, except as noted below or supplemented as follows.

##### 2.2 RECYCLED ASPHALT PAVEMENT (RAP) AND BASE MATERIAL

- A. Shall consist of the existing or imported recycled asphalt pavement, existing base course material and/or subgrade material. The base course and subgrade material shall not contain roots, topsoil, or any material deleterious to its reaction with cement. The particle distribution of the processed material shall be such that 100% passes a 3-inch (75 mm) sieve, at least 95% passes a 2-inch (50 mm) sieve, and at least 55% passes a No. 4 (4.75 mm) sieve.

##### 2.3 EQUIPMENT

- A. Cement Proportioning
  - 1. Cement shall be added in a dry form.
- B. Mixing Methods
  - 1. Mixing shall be accomplished in place, using single-shaft or multiple-shaft mixers. Agricultural disks or motor graders are not acceptable mixing equipment.

## PART 3 – CONSTRUCTION

### 3.1 GENERAL

- A. Refer to Section 208.03 of the Kentucky Standard Specifications, current edition, except as noted below or supplemented as follows.

### 3.2 PREPARATION OF EXISTING ROADWAY

- A. Any Manholes, valve covers, or other buried structures shall be protected from damage prior to processing.
- B. The subgrade shall be firm and able to support, without yielding or subsequent settlement, the construction equipment and the compaction of the FDR material.
  - 1. Soft or yielding subgrade shall be improved and made stable before construction proceeds. The method of improvement shall be recommended by the Project Geotechnical Engineer.

### 3.3 INITIAL PULVERIZATION

- A. Before cement is applied, initial pulverization shall be required to the full depth of mixing.
- B. Immediately prior to application of cement, if pulverized material is below optimum moisture content (ASTM D558), water shall be added. If pulverized material is more than 3 percent above optimum moisture content, the material shall be allowed adequate time to dry.
- C. The pulverized material shall be sealed and properly drained at the end of the day or if rain is expected.

### 3.4 APPLICATION OF CEMENT

- A. Cement shall be applied at the rate shown in Table 1 for the respective street section or as the Engineer directs.
- B. The time from cement placement on the pulverized material to start of mixing shall not exceed 30 minutes.

### 3.5 MIXING

- A. The final mixture (cement, bituminous surface, granular base, and subgrade soil) shall be pulverized such that 100% passes the 3-inch (75 mm) sieve, at least 95% passes the 2-in. (50 mm) sieve, and at least 55% passes the No. 4 (4.75 mm) sieve. No more than 75% of the final mixed material shall be made of the existing bituminous material unless approved by the engineer and included in a mixture design. Additional material can be added to the top or from the subgrade to improve the mixture gradation, as long as this material was included in the mixture design.

Table 1. Mix Design Table

STREET	STA. START	STA. END	FDR WIDTH (FT)	FDR DEPTH (IN)	ANTICIPATED MATERIAL IMPORT/EXPORT THICKNESS (IN)	MIX DESIGN	CEMENT APPLICATION RATE (LBS/SY OF FDR)	MAX. DRY DENSITY (LBS/CF)	OPTIMUM MOISTURE CONTENT (%)
CLUBHOUSE DRIVE	1+80	5+00	24	8	-0.75	1	45.12	127.3	9.6
CLUBHOUSE DRIVE	5+00	10+75	24	10	-1.5	1	56.40	127.3	9.6
CLUBHOUSE DRIVE	10+75	14+75	24	10	-0.5	1	56.40	127.3	9.6
CLUBHOUSE DRIVE	14+75	17+75	24	12	-2.0	1	67.68	127.3	9.6
CLUBHOUSE DRIVE	17+75	20+15	24	12	-1.0	1	67.68	127.3	9.6
CLUBHOUSE DRIVE	20+15	22+75	24	10	-0.5	1	56.40	127.3	9.6
CLUBHOUSE DRIVE	22+75	25+60	24	8	0.0	1	45.12	127.3	9.6
CLUBHOUSE DRIVE	25+60	29+32	24	10	-1.5	1	56.40	127.3	9.6
CLUBHOUSE DRIVE (END)	0+00	0+78	14	8	-2.0	3	47.92	136.1	7.3
MAPLE DRIVE & LAUREL DRIVE	0+00	6+50	14	10	2.5	1	56.40	127.3	9.6
MAPLE DRIVE & LAUREL DRIVE	6+50	10+87	14	10	2.0	1	56.40	127.3	9.6
WALNUT ROAD (EXISTING)	0+00	2+30	14	10	5.5	1	56.40	127.3	9.6
WALNUT ROAD (EXISTING)	2+30	4+20	14	10	1.5	1	56.40	127.3	9.6
WALNUT ROAD (EXISTING)	4+20	7+20	14	10	3.5	1	56.40	127.3	9.6
HILLTOP ROAD	0+00	3+50	14	10	4.5	1	56.40	127.3	9.6
HILLTOP ROAD	3+50	5+45	14	10	2.5	1	56.40	127.3	9.6
LAKESIDE DRIVE (SOUTH)	0+00	1+50	14	12	1.0	1	67.68	127.3	9.6
LAKESIDE DRIVE (NORTH) + LAKEVIEW ROAD	0+00	2+25	14	10	4.5	1	56.40	127.3	9.6
LAKESIDE DRIVE (NORTH) + LAKEVIEW ROAD	2+25	3+25	14	10	1.5	1	56.40	127.3	9.6
LAKESIDE DRIVE (NORTH) + LAKEVIEW ROAD	3+25	7+50	14	10	0.5	3	59.90	136.1	7.3
LAKESIDE DRIVE (NORTH) + LAKEVIEW ROAD	7+50	10+60	14	12	2.0	1	67.68	127.3	9.6
FAIRVALLEY ROAD + ASH ROAD	0+00	5+50	14	10	5.5	1	56.40	127.3	9.6
FAIRVALLEY ROAD + ASH ROAD	5+50	7+60	14	10	5.0*	1	56.40	127.3	9.6
TWIN LAKES DRIVE (NORTH)	0+00	3+00	14	10	4.0	2	56.40	132.7	8.6
TWIN LAKES DRIVE (NORTH)	3+00	7+75	14	10	2.5	3	59.90	136.1	7.3
TWIN LAKES DRIVE (SOUTH)	0+00	4+75	14	10	4.5	1	56.40	127.3	9.6
DOGWOOD ROAD	0+00	3+60	14	12	1.0	1	67.68	127.3	9.6
ELM ROAD	0+00	4+30	14	10	2.5	3	59.90	136.1	7.3
FOREST ROAD	0+00	5+10	14	10	3.5	1	56.40	127.3	9.6
HEMLOCK ROAD	0+00	2+75	14	10	3.0	1	56.40	127.3	9.6
HEMLOCK ROAD	2+75	5+60	14	10	2.0	1	56.40	127.3	9.6
IRVING ROAD	0+00	3+10	14	10	1.5	1	56.40	127.3	9.6
JERICO ROAD	0+00	2+50	14	10	1.5	1	56.40	127.3	9.6
JERICO ROAD	2+75	8+70	14	10	1.0	1	56.40	127.3	9.6
CEDAR ROAD + GROVE ROAD	0+00	7+00	14	10	3.5**	1	56.40	127.3	9.6
CEDAR ROAD + GROVE ROAD	7+00	10+55	14	10	2.5	1	56.40	127.3	9.6
CEDAR ROAD + GROVE ROAD	10+55	12+05	14	12	0.0	1	67.68	127.3	9.6
CEDAR ROAD + GROVE ROAD	12+05	16+60	14	10	2.5	1	56.40	127.3	9.6
OAK ROAD	0+00	2+00	14	12	2.0	1	67.68	127.3	9.6
OAK ROAD	2+00	2+30	14	12	0.0	1	67.68	127.3	9.6
LOCUST ROAD	0+00	7+05	14	10	4	1	56.40	127.3	9.6

\*Denotes area where #2 Crushed Limestone was used to fill ruts in the road before 2014 pavement overlays. See sheet 3 for more information.

\*\*Denotes area where reinforced concrete patch was encountered during drilling. See sheet 3 for more information.

- B. Mixing shall be continued until the cement is uniformly dispersed throughout the mix and until the product is uniform in color, meets gradation requirements, and is at the required moisture content.

### 3.6 COMPACTION AND SURFACE FINISH

- A. The processed material shall be uniformly compacted to at least 98 percent of maximum density, ASTM D558.
- B. If necessary, or as required by the Engineer, the surface shall be lightly scarified and re-compacted to remove imprints left by equipment.
- C. Final dimensions shall conform to the lines, grades, thicknesses, and typical cross sections shown in the plans.

### 3.7 CURING AND PROTECTION

- A. Completed portions of the FDR Base may be opened immediately to low-speed local traffic, provided the asphalt curing seal has been placed and provided the FDR base and underlying subgrade are sufficiently stable to withstand marring or permanent deformation.
  - 1. The ability of the FDR Base and underlying subgrade to withstand marring or permanent deformation shall be determined by means of a proofroll with a fully-loaded single or tandem axle dump truck.
    - a. The proofroll shall be conducted as soon as possible after completion of compaction of the FDR Base.
    - b. Marring or permanent deformation shall be corrected in accordance with Section 3.8.A of this specification.
  - 2. After passing the proofroll, an asphalt curing seal shall be applied to the FDR Base.
  - 3. The Contractor shall stage construction in such a way to minimize the construction traffic on completed portions of FDR Base.
  - 4. The Contractor shall stage construction to limit the amount of time that residents are without access to their homes.
- B. Subsequent pavement layers may be placed any time after placement of the asphalt curing seal provided the FDR Base and underlying subgrade are sufficiently stable to withstand marring or permanent deformation.

- C. The section may be opened up to all traffic after the FDR base has received a curing compound and subsequent surface layers and the FDR Base and underlying subgrade are sufficiently stable to withstand marring or permanent deformation.
  - 1. The Contractor shall stage construction in such a way to minimize the construction traffic on streets after completion of paving operations.
- D. Cores for unconfined compression tests are not required.

3.8 MAINTENANCE

- A. Maintenance shall include immediate repairs of any defects that may occur. If it is necessary to replace any processed material, the replacement shall be for the full depth, with vertical cuts, using either new cement-treated material or low strength concrete (300 to 500 psi compressive strength). No skin patches will be permitted.

3.9 INSPECTION AND TESTING

- A. The Engineer, with the assistance and cooperation of the contractor, shall make such inspections and tests as deemed necessary to ensure the conformance of the work to the contract documents. These inspections and tests may include, but shall not be limited to:
  - 1. Obtaining test samples of the cement-treated material and its individual components at all stages of processing and after completion.
  - 2. Performing field density, moisture, and gradation tests.
  - 3. Observing the operation of all equipment used on the work. Only those materials, machines, and methods meeting the requirements of the contract documents shall be used unless otherwise approved by the Engineer.
  - 4. Refer to Table 2 for minimum frequency of testing.

**Table 2. Minimum Frequency of Testing**

Test	Applicable Test Standard	Minimum Frequency	Notes
Moisture-Density Tests	ASTM D558	1 per 2,000 feet of roadway	
Moisture Content (Before Cement Application)	ASTM D4959	1 per 300 feet of roadway	Moisture content shall be between optimum and 3% above optimum.
Cement Application		1 daily per each application rate	Technician shall use plate or canvas with calibrated surface area to capture the applied cement. The weight of the captured cement shall be compared to the application rate specified in Table 1.
Sieve		1 per 2,000 feet of roadway	Refer to Section 3.5.A for gradation requirements of pulverized material.
Treatment Depth/Uniformity		4 for entire project	At four locations, as directed by the Engineer, dig to the base of pulverized, cement treated material to inspect treatment depth and uniformity of color.
Treatment Depth			Using graduated depth probe, technician shall check depth of pulverization at random locations.
Moisture Content (Before Compaction)	ASTM D4959	1 per 600 feet of roadway	Moisture content shall be between optimum and 2% above optimum.
Compaction	ASTM D6938 or ASTM D1556	1 per 300 feet of roadway	Compact to 98% of maximum dry density with moisture content between optimum and 2% above optimum.
Proofroll		1 for each completed portion of FDR Base prior to curing seal application	Technician shall visually monitor progress of a fully-loaded single or tandem axle dump truck.

Note that the frequency of testing listed in this table is a minimum and higher frequency of testing may be directed by the Engineer in the field as conditions warrant.

**PART 4 – MEASUREMENT**

**4.1 GENERAL**

A. Refer to Section 01025 of this Specifications Book.

**PART 5 - PAYMENT**

**5.1 GENERAL**

A. Refer to Section 01025 of this Specifications Book.

++END OF SECTION++

## SECTION 02425

### PAVEMENT STRIPING

#### PART 1 - GENERAL

##### 1.1 WORK INCLUDED

- A. The Contractor shall furnish all materials, equipment, tools, and labor necessary to do the work shown on the contract drawings.

##### 1.2 CONTRACTOR CERTIFICATION

- A. The Contractor shall submit a written certification to the County, after completion, stating that the materials, thickness and application meet KYTC Specifications. The certification shall be on the Contractor's stationary and signed by an official of the company.

##### 2.1 PAINT MARKINGS

- A. Traffic paint, (white, lead-free yellow, and other, if specified), shall be fast drying waterborne traffic paint.
- B. **These products shall meet all of the specifications and performance requirements of the 2008 (or latest version) of the Kentucky Department of Transportation.**
- C. These paint products are to be formulated without lead containing pigments.

##### 2.2 THERMOPLASTIC PAVEMENT MARKINGS

- A. **Thermoplastic pavement markings application and materials shall meet all appropriate Kentucky Transportation Specifications.**
- B. Kentucky Transportation Cabinet (KYTC) will require thermoplastic pavement markings at intersections with state maintained highways. The required thermoplastic markings for this project are shown on the striping plan.

#### PART 3 - EXECUTION

##### 3.1 APPLICATION STRIPING TRUCKS

- A. Waterborne traffic paints are designed for application through long-line striping trucks that have been properly equipped to apply waterborne traffic paints. The trucks must be self-propelled and capable of heating the paint to provide uniform flow and enhance quick drying of the paint.
- B. This striper must have a guide boom or optical pointer in order to attain smooth and straight lines. The equipment must use air pressure or pump pressure to

maintain proper paint pressure at all times. The equipment shall be capable of applying a single line or parallel lines of the specified width and in any combination of a skip line and a solid line in one pass.

- C. The equipment shall be equipped with a paint cutoff device to provide clean, square marking ends of the lines.
- D. The paint pots or tanks shall be equipped with an agitator that will keep the paint thoroughly mixed.
- E. The equipment shall be equipped with bead dispensers, one for each paint spray gun, placed such that the beads are applied to the paint almost instantly as the paint is being placed on the roadway surface. The bead dispensers shall be equipped with cutoff controls synchronized with the cutoff controls for the paint spray guns.
- F. The equipment shall utilize metal parts of stainless steel and hoses that have chemical resistance to high pH properties of the latex resins.

### 3.2 APPLICATION WALK BEHIND EQUIPMENT

- A. In the event that a walk behind striping application is necessary, (due to space/confinement issues), on public streets or striping of private/public parking lots, etc; it is important that the same considerations be given to the materials of construction as with the long line equipment.

### 3.3 APPLICATION CONDITIONS

- A. Surfaces shall be clean, dry, and free from loose or peeling paint.
- B. Traffic paints shall be applied when air or surface temperatures are above 50°F or below 130°F.
- C. Contractor to inspect the surface for moisture and the presence of concrete sealers or other residue on new concrete surfaces. Contractor shall make the County Inspector aware of the above conditions prior to proceeding.
- D. Previously painted lines may be repainted without additional surface preparation provided the old paint is still tightly adhered to the surface.

### 3.4 APPLICATION RATES

- A. The film thickness shall be 15 mils (approximately .110 sq. ft./gal).



3.5 RECORDS

- A. The Contractor shall video record the existing street striping before construction. No deviations shall occur unless indicated on the plans.

3.6 MARKING REMOVAL

- A. Any markings done in error or which do not conform to the traffic operation in use must be removed. Markings on existing or temporary pavement shall be removed by water blasting to the satisfaction of the County Inspector. Painting of existing markings with bituminous or other material to obliterate the markings shall not be allowed.

++ END OF SECTION ++

(This page left blank intentionally)

SECTION 02500

STORM SEWERS

PART 1 – GENERAL

1.1 DESCRIPTION

- A. All materials and construction methods are to be in accordance with the Sanitation District 1 specifications for Storm Sewer, most current edition, unless otherwise noted on the project plans or these specifications.

PART 2 – PRODUCTS (NOT USED)

PART 3 – EXECUTION (NOT USED)

++ END OF SECTION ++

(This page left blank intentionally)

## SECTION 02700

### RESTORATION - SEED

#### PART 1 – GENERAL

##### 1.1 SUMMARY

- A. This Section includes the following:  
Preparation and seeding of all unpaved areas disturbed under this contract.

##### 1.2 PURPOSE

- A. The purpose of this section is to provide a directive for restoration of private and public unpaved areas. The following guidelines will ensure that the disturbed areas are restored to the same or superior quality that existed prior to construction.
- B. The CONTRACTOR should read this section, review the site, and discuss with the ENGINEER any necessary deviations considered. Please also review any special notes within the bid packet.
- C. For restoration of paved areas, please review the appropriate section in the specifications and/or special notes within the bid packet.

##### 1.3 RELATED DOCUMENTS

- A. Drawings and general provisions of the Contract, including General, and Supplementary Conditions, and Earthwork related sections apply to this Section.
- B. Provisions of these specifications do not relieve the CONTRACTOR from any permitting requirements of regulatory agencies.

##### 1.4 SUBMITTALS

- A. Submit each item in this Article according to Conditions of Contract and General and Special Conditions sections within these specifications.
- B. Seed vendor's certified statement for grass seed mixture, stating botanical and common name, percentage by weight and percentages of purity, germination and weed seed for each grass seed species.

##### 1.5 QUALITY ASSURANCE

- A. Seeding to be performed by a single firm specializing in seeding.

##### 1.6 PRODUCT DELIVERY, STORAGE, AND HANDLING

- A. Packaged Materials: deliver packaged materials in containers showing weight, analysis and name of manufacturer. Protect materials from deterioration during deliver and while stored at the site.

1.7 PROJECT CONDITIONS

- A. Installer must examine the subgrade, verify the elevations, observe the conditions under which landscape operations are to be performed, and notify the CONTRACTOR of unsatisfactory conditions. Do not proceed until unsatisfactory conditions have been corrected in a manner acceptable to the Installer.
- B. Proceed with and complete seeding as rapidly as portions of the site become available, working within the seasonal limitations for operations required.
- C. Continue to maintain erosion control measures as required throughout project duration.

1.8 WARRANTY

- A. Special Warranty: Warrant lawns through the specified maintenance and warranty period.
- B. Warranty Period: 1 year after Substantial Completion.
- C. The special warranty specified in this Article shall not deprive the OWNER of other rights the OWNER may have under other provisions of the Contract Documents and shall be in addition to and run concurrent with, other warranties made by the CONTRACTOR under requirements of the Contract Documents.

PART 2 - PRODUCTS

2.1 TOPSOIL

- A. Topsoil will be provided under related Earthwork Sections. If quantity of topsoil is insufficient, installer is to notify the General CONTRACTOR of the unsatisfactory condition.
- B. POOR TOPSOIL MAY REQUIRE ADDITIONAL SHREDDED TOPSOIL TO BE DELIVERED TO SITE.
- C. Topsoil shall not contain more than 40 percent clay in that portion passing a No. 10 sieve and shall contain not less than 5 percent or more than 20 percent organic matter as determined by loss on ignition of samples oven dried to constant weight at 212 degrees Fahrenheit.

2.2 GRASS MATERIALS

- A. Provide fresh, clean, new-crop seed complying with the tolerance for purity and germination established by the Official Seed Analysts of North America. Provide seed of the species and proportions as specified.
- B. All seeding shall meet the standards of the governmental agency having jurisdiction. The CONTRACTOR shall: (1) examine the site and notify the OWNER of any special turf (i.e. zoysia grass) requirements that exist, and (2) meet with the necessary agencies to determine specifications prior to seeding.

- C. The following is a general guideline to be utilized as a minimum specification:

Urban Areas. All areas to be seeded which are considered to be urban in character, and any that are in front of a residence, shall be seeded with the following mixture: (percentages are by weight.)

40% Kentucky Bluegrass (*Poa pratensis*)  
40% Creeping Red Fescue (*Festuca rubra*)  
20% Annual Ryegrass (*Lolium multiflorum*)

Rights of Ways and Easements. All areas in rights-of-way or in easements adjacent to rights-of-way, other than urban areas, shall be seeded with the following mixture:

30% Kentucky Bluegrass (*Poa pratensis*)  
50 % Kentucky 31 Tall Fescue (*Festuca arundinaces* V<sub>ar.</sub> KY 31)  
20% Annual Ryegrass (*Lolium multiflorum*)

Replant special plugged turf as necessary conforming to pre-construction conditions.

All other areas: All other areas shall be seeded with the following mixture:

90% Perennial Ryegrass (*Lolium perenne*)  
10% Alsike Clover (*Trifolium hybridum*)

Seed mixtures shall include fine fescues, tall fescues, perennial rye grass, annual ryegrass, and Kentucky bluegrass from the following selections:

Fine Fescue: Banner III, Brittany III, Creeping Red Fescue, Eco, Jasper, Longfelolow, Shademaster II, Shadow II, SR 5100, Victory II, Spartan, Aurora, Valiant, Biljart, Scaldis, Reliant, Waldina.

Perennial Rye Grass: Brightstar II, Catalina, Chaparral, Divine, Imagine, Legacy II, Line Drive, Majesty, Panther, Pennant II, Prelude III, Premier II, Rebel III, Roadrunner, Wind Dancer, Gator, Tara, Allstar, Blazer, Derby, Repell, Fiesta, Palmer, or Bride II.

Kentucky Bluegrass: America, Award, Eclipse, Glade, Jefferson, Midnight, NuGlade, Odyssey, Quantum Leap, Rugby II, Total Eclipse, Unique, Aspen Emmundt, Mosa American, Somerset, Vanessa, Majestic, Adelphi, or Merit.

- D. Unless otherwise specified or shown on the drawings, all graded/disturbed areas shall be finely graded to contour of existing lawn (as photographed before construction), and left smooth and thickly sown with seed as specified and/or such other grasses as are specified by the ENGINEER.

## 2.3 SOIL ADDITIVES

- A. The CONTRACTOR should contact the U.S. Department of Agriculture, Natural Resources Conservation Service, 6028 Camp Ernst Road, Burlington, KY 41005, 586-7903 (Fax 586-6107) or other local USDA office in the project locale for testing and advice before seeding. In the absence of certified soil tests, one of the following soil additive methodologies shall be applied at the rates specified:

Methodology #1:

Commercial Fertilizer: Apply one of the following commercial grade fertilizer of neutral character (fertilizer to be spread at the recommended rates specified by the manufacturer):

30 lbs (max) per 1000 square feet of 5-10-5

25 lbs (max) per 1000 square feet of 10-10-10

10 lbs (max) per 1000 square feet of 5-20-20; **AND**

Lime: natural limestone ASTM C602 Class T with a minimum 99 percent passing through No. 8 sieve and a minimum of 75 percent passing through No. 60 sieve.

Spread 2 tons lime per acre (80 lbs per 1000 square feet).

**OR: Methodology #2:**

Organic Matter: For residential lawns only, apply 2 Cubic Yards per 1000 square feet of either: Peat Moss; well-decomposed sawdust; well-rotted, weed-free manure; organic compost; or sewage sludge (non-industrial).

Miscellaneous Landscape Materials:

Anti-Erosion Mulch: Provide clean, seed-free salt hay or threshed straw of wheat, rye, oats or barley.

Erosion Control Products: Degradable Erosion Control Blankets on embankments greater than 3:1 slopes. Follow manufacture's recommended installation specifications.

PART 3 - EXECUTION

3.1 GENERAL

- A. The CONTRACTOR shall provide all labor, materials, tools, and equipment required to grade, fertilize, seed, and mulch in good, workmanlike manner the areas where shown on the plans or where directed by the ENGINEER and as specified herein.

3.2 PREPARATION FOR LAWNS

- A. Loosen sub-grade of lawn areas to a minimum depth of 4" by disking or harrowing. Remove stones over 3/4" in any dimension and sticks, roots, rubbish and other extraneous matter with power equipment. Limit preparation to areas that will be seeded promptly after preparation.
- B. Mix specified soil amendments and fertilizers with topsoil at the rates specified by disking or harrowing. Delay mixing of fertilizer if seeding will not follow within a few days.
- C. The CONTRACTOR is to grade lawn areas to a smooth even surface with loose uniformly fine texture. Roll, rake, remove ridges and fill depressions, as required to meet finish grades and prevent puddling of water. All grass, weed, roots,



sticks, stones, and other debris are to be removed and the soil carefully brought to the finished grade by hand raking. Limit fine grading to areas that will be seeded immediately after grading. The final seedbed should be firm and free of large clods, rocks, and other extraneous material.

- D. Moisten prepared lawn areas before seeding if soil is dry. Water thoroughly and allow surface to dry before seeding lawns. Do not create a muddy soil condition.
- E. Restore lawn areas to specified condition if eroded or otherwise disturbed after fine grading and prior to seeding.

### 3.3 SEEDING LAWNS

- A. Seeding shall be broadcast over the prepared area at 7 pounds per 1000 square feet.
- B. Do not use wet seed or seed that is moldy or otherwise damaged.
- C. Sow seed using a spreader or seeding machine.
- D. Do not seed when wind velocity exceeds 5 mi. per hr.
- E. Distribute seed evenly over entire area by sowing equal quantity in 2 directions at right angles to each other.
- F. Sow not less than the quantity of seed specified.
- G. Rake seed lightly into the top 1/8" of the soil and compact with cultipacker.
- H. Protect seeded areas against erosion by spreading specified lawn mulch after completion of seeding operations.
- I. Spread uniformly to form a continuous blanket not more than 1" loose measurement over seeded areas. The mulch covering should be thin enough to expose about 50% percent of the soil surface (one to two bales per 1000 square feet).
- J. At CONTRACTOR'S option, the method of placing and tying down straw using an asphaltic emulsion as described in KY Transportation Cabinet Department of Highways Standard Specifications for Road and Bridge Construction, 2000, Section 212.03.03 Procedure B may be used. Asphaltic Emulsion shall be nontoxic to plants, and shall conform to AASHTO M140 or AASHTO M208.
- K. Install Degradable Erosion Control Blankets on all slopes greater than 3:1. Utilize manufacturers recommended installation specifications.

3.4 MAINTENANCE

- A. Begin maintenance immediately after seeding.
- B. Maintain lawns for not less than the period stated below and longer as required to establish an acceptable lawn.
- C. Seeded lawns: not less than 60 days.
- D. If seeded in fall and not given full 60 days of maintenance, or if not considered acceptable at the time, continue maintenance the following spring until acceptable lawn is established.
- E. Maintain lawns by watering, fertilizing, weeding, mowing, and other operations such as rolling, re-grading and seeding as required to establish a smooth, acceptable lawn, free of eroded or bare areas.
- F. CONTRACTOR shall include a minimum of one mowing.
- G. The CONTRACTOR prior to final acceptance shall accomplish any necessary reseeding or repairing.

3.5 CLEAN UP AND PROTECTION

- A. During seeding operations, store materials and equipment where directed. Keep pavements clean and areas of construction in an orderly condition.
- B. Protect lawns and materials from damage due to landscape operations, operations by other CONTRACTORS and trades, and trespassers. Maintain protection during installation and maintenance periods.

3.6 INSPECTION AND ACCEPTANCE

- A. When seeding operations are completed, including maintenance, the ENGINEER will, upon request, make an inspection to determine acceptability.
- B. When inspected lawns do not comply with the requirements, replace rejected lawns and continue specified maintenance until re-inspected by the ENGINEER and found to be acceptable.

++END OF SECTION++

## SECTION 02800

### RESTORATION – SOD

#### PART 1 - GENERAL

##### 1.1 SUMMARY

- A. This Section includes the following:  
Preparation and seeding of all unpaved areas disturbed under this contract.

##### 1.2 PURPOSE

- A. The purpose of this section is to provide an alternative method for restoration of private and public lawns. Sodding will be required when a quick solution is necessary or due to surface drainage issues. This section will be used instead of or in addition to the previous restoration (Seeding) specifications. The following guidelines will ensure that the disturbed areas are restored to the same or superior quality that existed prior to construction.
- B. The CONTRACTOR should read this section, review the site, and discuss with the ENGINEER any necessary deviations considered. Please also review any special notes within the bid packet.
- C. For restoration of paved areas, please review the appropriate section in the specifications and/or special notes within the bid packet.

##### 1.3 RELATED DOCUMENTS

- A. Drawings and general provisions of the Contract, including General, and Supplementary Conditions, and Earthwork related sections apply to this Section.
- B. Provisions of these specifications do not relieve the CONTRACTOR from any permitting requirements of regulatory agencies.

##### 1.4 SUBMITTALS

- A. Submit each item in this Article according to Conditions of Contract and General and Special Conditions sections within these specifications.
- B. Sod vendor's certified statement for grass sod mixture, stating botanical and common name, percentage by weight and percentages of purity, germination and weeds for each grass species.

##### 1.5 QUALITY ASSURANCE

- A. Sodding to be performed by a single firm specializing in sodding.

1.6 PRODUCT DELIVERY, STORAGE, AND HANDLING

- A. Packaged Materials: deliver packaged materials in containers showing weight, analysis and name of manufacturer. Protect materials from deterioration during deliver and while stored at the site.

1.7 PROJECT CONDITIONS

- A. Installer must examine the subgrade, verify the elevations, observe the conditions under which landscape operations are to be performed, and notify the CONTRACTOR of unsatisfactory conditions. Do not proceed until unsatisfactory conditions have been corrected in a manner acceptable to the Installer.
- B. Proceed with and complete sodding as rapidly as portions of the site become available, working within the seasonal limitations for operations required.
- C. Continue to maintain erosion control measures as required throughout project duration.

1.8 WARRANTY

- A. Special Warranty: Warrant lawns through the specified maintenance and warranty period.
- B. Warranty Period: 1 year after Substantial Completion.
- C. The special warranty specified in this Article shall not deprive the OWNER of other rights the OWNER may have under other provisions of the Contract Documents and shall be in addition to and run concurrent with, other warranties made by the CONTRACTOR under requirements of the Contact Documents.

PART 2 - PRODUCTS

2.1 TOPSOIL

- A. Topsoil will be provided under related Earthwork Sections. If quantity of topsoil is insufficient, installer to notify the General CONTRACTOR of the unsatisfactory condition.
- B. POOR TOPSOIL MAY REQUIRE ADDITIONAL SHREDDED TOPSOIL TO BE DELIVERED TO SITE.
- C. Topsoil shall not contain more than 40 percent clay in that portion passing a No. 10 sieve and shall contain not less than 5 percent or more than 20 percent organic matter as determined by loss on ignition of samples oven dried to constant weight at 212 degrees Fahrenheit.

## 2.2 GRASS MATERIALS

- A. Provide fresh, clean, new-crop, nursery grown sod.
- B. Sod shall be free of objectionable grassy and broadleaf weeds. Sod will not be acceptable if it contains any of the following weeds: common Bermudagrass (wiregrass), quackgrass, johnsongrass, poison ivy, nutsedge, nimblewill, Canada thistle, bindweed, bentgrass, wild garlic, ground ivy, perennial sorrel, and bromegrass.
- C. Sod mixtures shall include fine fescues, tall fescues, perennial rye grass, annual ryegrass, and Kentucky bluegrass from the following selections:
- Fine Fescue: Banner III, Brittany III, Creeping Red Fescue, Eco, Jasper, Longfelolow, Shademaster II, Shadow II, SR 5100, Victory II, Spartan, Aurora, Valiant, Biljart, Scaldis, Reliant, Waldina.
- Perennial Rye Grass: Brightstar II, Catalina, Chaparral, Divine, Imagine, Legacy II, Line Drive, Majesty, Panther, Pennant II, Prelude III, Premier II, Rebel III, Roadrunner, Wind Dancer, Gator, Tara, Allstar, Blazer, Derby, Repell, Fiesta, Palmer, or Bride II.
- Kentucky Bluegrass: America, Award, Eclipse, Glade, Jefferson, Midnight, NuGlade, Odyssey, Quantum Leap, Rugby II, Total Eclipse, Unique, Aspen Emmundt, Mosa American, Somerset, Vanessa, Majestic, Adelphi, or Merit.
- D. Thickness of cut: Sod shall be machine cut at a uniform soil thickness of 5/8" plus or minus 1/4" at the time of cutting. Measurement for thickness shall exclude top growth and thatch.
- E. Pad size: Individual pieces of sod shall be cut to the supplier's standard width and length. Maximum allowable deviation from the standard width and length shall be +/- 1/2" on width and +/- 5 percent on length. Broken pads and torn or uneven ends will not be accepted.
- F. Strength of Sod Sections: Standard size sections of sod shall be strong enough to support their own weight and retain their size and shape when supported vertically from a firm grasp on the upper 10 percent of the section.
- G. Moisture Content: Sod shall not be harvested or transplanted when moisture content is excessively wet or dry and may adversely affect the sod's survival.
- H. Time Limitations: Sod shall be harvested, delivered and transplanted within a 36 hour period unless suitable preservation method is approved prior to delivery.
- I. Mowing Height: Before stripping, sod shall be mowed uniformly at a 2" height.

## 2.3 SOIL ADDITIVES

- A. The CONTRACTOR should contact the U.S. Department of Agriculture, Natural Resources Conservation Service, 6028 Camp Ernst Road, Burlington, KY 41005, 586-7903 (Fax 586-6107) or other local USDA office in the project locale for testing and advice before sodding. In the absence of certified soil tests, one of the following soil additive methodologies shall be applied at the rates specified:

### Methodology #1:

Commercial Fertilizer: Apply one of the following commercial grade fertilizer of neutral character (fertilizer to be spread at the recommended rates specified by the manufacturer):

- 30 lbs (max) per 1000 square feet of 5-10-5
- 25 lbs (max) per 1000 square feet of 10-10-10
- 10 lbs (max) per 1000 square feet of 5-20-20; AND

Lime: natural limestone ASTM C602 Class T with a minimum 99 percent passing through No. 8 sieve and a minimum of 75 percent passing through No. 60 sieve.

Spread 2 tons lime per acre (80 lbs per 1000 square feet).

### OR: Methodology #2:

Organic Matter: For residential lawns only, apply 2 Cubic Yards per 1000 square feet of either: Peat Moss; well-decomposed sawdust; well-rotted, weed-free manure; organic compost; or sewage sludge (non-industrial).

## PART 3 - EXECUTION

### 3.1 GENERAL

- A. The CONTRACTOR shall provide all labor, materials, tools, and equipment required to grade, fertilize, and sod in good, workmanlike manner the areas where shown on the plans or where directed by the ENGINEER and as specified herein.

### 3.2 PREPARATION FOR LAWNS

- A. Loosen sub-grade of lawn areas to a minimum depth of 4" by disking or harrowing.
- B. Remove stones over 3/4" in any dimension and sticks, roots, rubbish and other extraneous matter with power equipment. Limit preparation to areas that will be sodded promptly after preparation.
- C. Mix specified soil amendments and fertilizers with topsoil at the rates specified by disking or harrowing. Delay mixing of fertilizer if sodding will not follow within a few days.

- D. The CONTRACTOR is to grade lawn areas to a smooth even surface with loose uniformly fine texture. Roll, rake, remove ridges and fill depressions, as required to meet finish grades and prevent puddling of water. All grass, weed, roots, sticks, stones, and other debris are to be removed and the soil carefully brought to the finished grade by hand raking. Limit fine grading to areas that will be sodded immediately after grading. The final grade should be firm and free of large clods, rocks, and other extraneous material.
- E. Moisten prepared lawn areas before sodding if soil is dry. Water thoroughly and allow surface to dry before seeding lawns. Do not create a muddy soil condition.
- F. Restore lawn areas to specified condition if eroded or otherwise disturbed after fine grading and prior to sodding.

### 3.3 SODDING

- A. Lay sod within 36 hours from time of stripping. Do not plant dormant sod or if ground is frozen.
- B. Lay sod to form a solid mass with tightly fitted joints. Butt ends and sides of sod strips; do not overlap. Stagger strips to offset joint in adjacent courses. Work from boards to avoid damage to subgrade or sod. Tamp or roll lightly to ensure contact with subgrade.
- C. Work sifted soil into minor cracks between pieces of sod; remove excess to avoid smothering of adjacent grass.
- D. Anchor sod on slopes greater than 4:1 with wood pegs to prevent slippage.
- E. Water sod thoroughly with fine spray immediately after planting.

### 3.4 MAINTENANCE

- A. Begin maintenance immediately after sodding.
- B. Maintain lawns for not less than two weeks or until sod is well rooted and cannot be lifted out of place.
- C. Maintain lawns by watering, fertilizing, weeding, mowing, and other operations such as rolling, re-grading and seeding as required to establish a smooth, acceptable lawn, free of eroded or bare areas.
- D. CONTRACTOR shall include a minimum of one mowing.
- E. The CONTRACTOR prior to final acceptance shall accomplish any necessary resodding.

3.5 CLEAN UP AND PROTECTION

- A. During sodding operations, store materials and equipment where directed. Keep pavements clean and areas of construction in an orderly condition.
- B. Protect lawns and materials from damage due to landscape operations, operations by other CONTRACTORS and trades, and trespassers. Maintain protection during installation and maintenance periods.

3.6 INSPECTION AND ACCEPTANCE

- A. When sodding operations are completed, including maintenance, the ENGINEER will, upon request, make an inspection to determine acceptability.
- B. Sodding will be considered acceptable when all specified requirements, including maintenance period, have been complied with and a healthy, uniform, close stand of grass has been established, free of weeds, surface irregularities and bare spots larger than 1-1/2" diameter, open joints, and surface irregularities.
- C. When inspected lawns do not comply with the requirements, replace rejected lawns and continue specified maintenance until re-inspected by the ENGINEER and found to be acceptable.

++END OF SECTION++



**APPENDIX A**

**BID PACKETS**

(This page was left blank intentionally)

*2 PLASTIC POCKETS*

*GO HERE FOR BID SHEETS*

(This page was left blank intentionally)

**APPENDIX B**  
**MISCELLANEOUS FORMS**

(This page was left blank intentionally)

*PLASTIC POCKET GOES HERE FOR JOB FORMS*

(This page was left blank intentionally)



**APPENDIX C**  
**STANDARD DRAWINGS**

(This page was left blank intentionally)

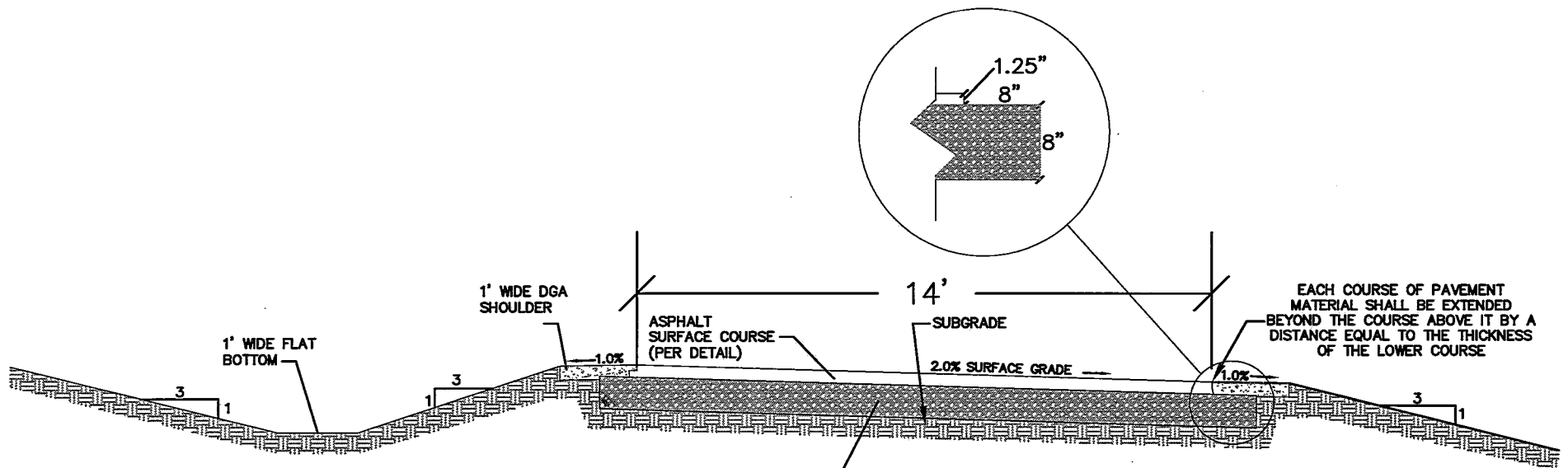

- FULL DEPTH RECLAMATION (FDR)**
1. SEE SHEET 3 FOR WHETHER OR NOT MATERIAL NEEDS TO BE IMPORTED, EXPORTED, OR IF THE EXISTING PAVEMENT THICKNESS IS SATISFACTORY FOR PROPOSED FDR.
  2. EXISTING PAVEMENT COMPOSITION FOR EACH STREET IS PROVIDED ON SHEET 4.
  3. FOR AREAS OF WIDENING THE EXISTING STREET, CONTRACTOR SHALL ADD APPROVED MATERIAL PRIOR TO PULVERIZATION. SEE DETAIL #3.

- THIS IS THE TYPICAL SECTION FOR THE FOLLOWING STREETS:**
- LAUREL STREET
  - MAPLE ROAD
  - GROVE ROAD {STA. 6+00 - STA. 16+69}
  - JERICHO ROAD {STA. 0+00 - STA. 2+50}
  - LAKESIDE DRIVE (NORTH) {STA. 0+00 - STA. 2+00}

#1A TYPICAL SECTION

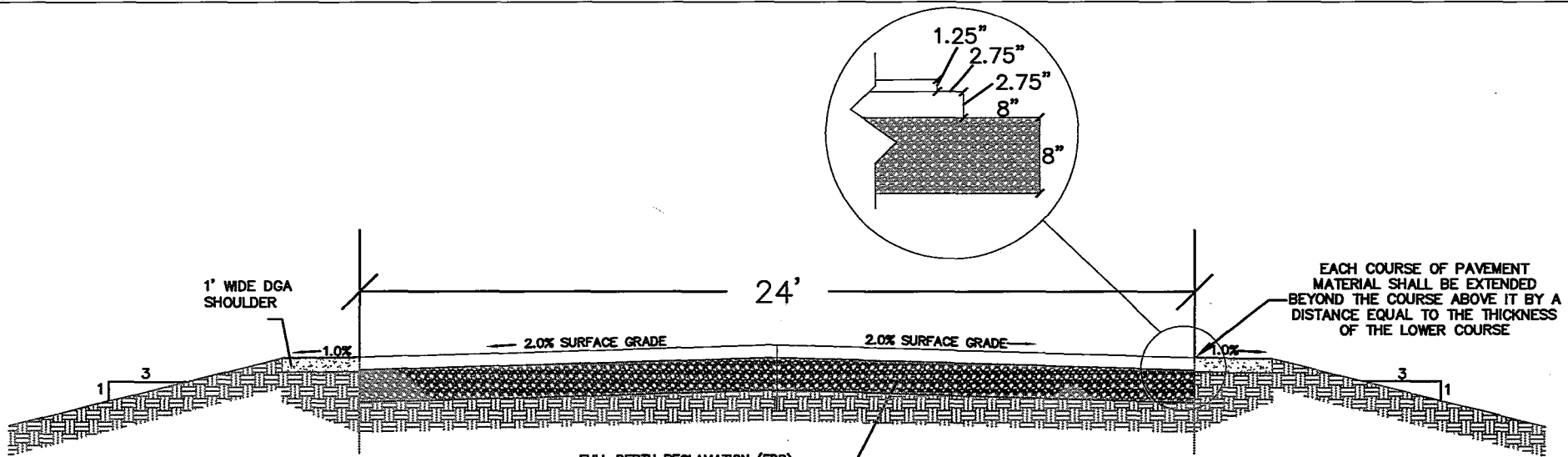

1' WIDE DGA SHOULDER

24'

2.0% SURFACE GRADE

2.0% SURFACE GRADE

EACH COURSE OF PAVEMENT MATERIAL SHALL BE EXTENDED BEYOND THE COURSE ABOVE IT BY A DISTANCE EQUAL TO THE THICKNESS OF THE LOWER COURSE

- FULL DEPTH RECLAMATION (FDR)
1. SEE SHEET 3 FOR WHETHER OR NOT MATERIAL NEEDS TO BE IMPORTED, EXPORTED, OR IF THE EXISTING PAVEMENT IS SATISFACTORY FOR FDR.
  2. EXISTING SUBGRADE COMPOSITION FOR EACH STREET IS PROVIDED ON SHEET 4.
  3. FOR AREAS OF WIDENING THE EXISTING STREET, CONTRACTOR SHALL ADD APPROVED MATERIAL PRIOR TO PULVERIZATION.

THIS IS THE TYPICAL SECTION FOR THE FOLLOWING STREETS:  
 • CLUBHOUSE DRIVE {STA. 0+00 - STA. 4+65}

#1B TYPICAL SECTION

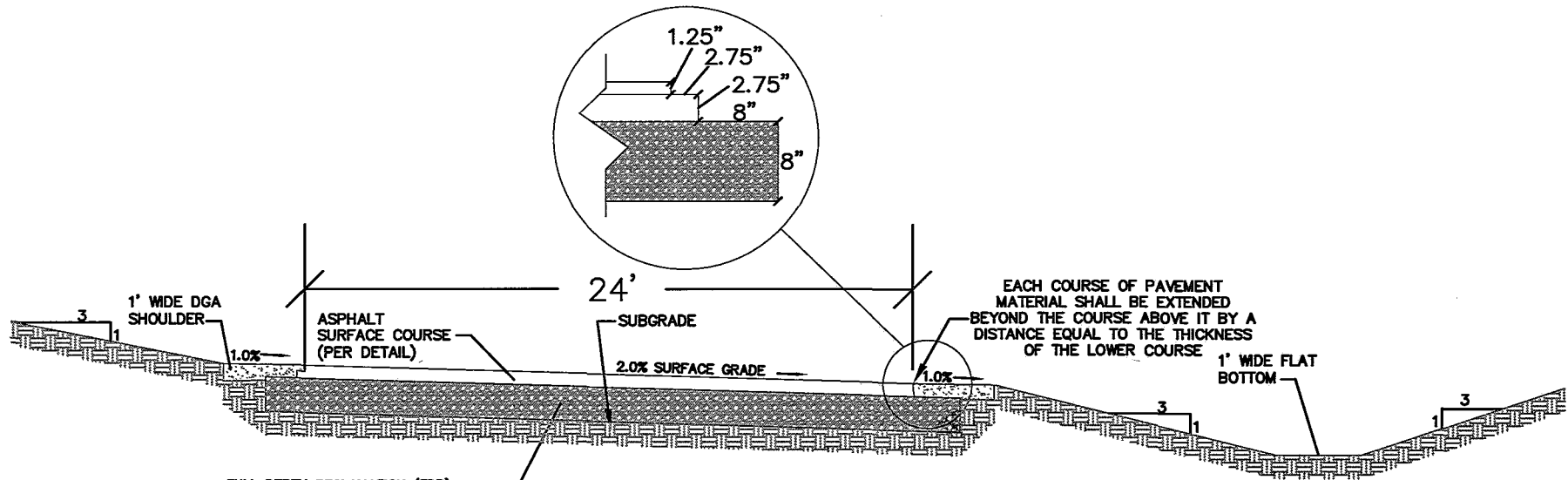

EACH COURSE OF PAVEMENT MATERIAL SHALL BE EXTENDED BEYOND THE COURSE ABOVE IT BY A DISTANCE EQUAL TO THE THICKNESS OF THE LOWER COURSE

- FULL DEPTH RECLAMATION (FDR)
1. SEE SHEET 3 FOR WHETHER OR NOT MATERIAL NEEDS TO BE IMPORTED, EXPORTED, OR IF THE EXISTING PAVEMENT THICKNESS IS SATISFACTORY FOR PROPOSED FDR.
  2. EXISTING PAVEMENT COMPOSITION FOR EACH STREET IS PROVIDED ON SHEET 4.
  3. FOR AREAS OF WIDENING THE EXISTING STREET, CONTRACTOR SHALL ADD APPROVED MATERIAL PRIOR TO PULVERIZATION. SEE DETAIL #3.

THIS IS THE TYPICAL SECTION FOR THE FOLLOWING STREETS:  
 • CLUBHOUSE DRIVE {STA. 5+35 TO STA. 29+15}

#1C TYPICAL SECTION

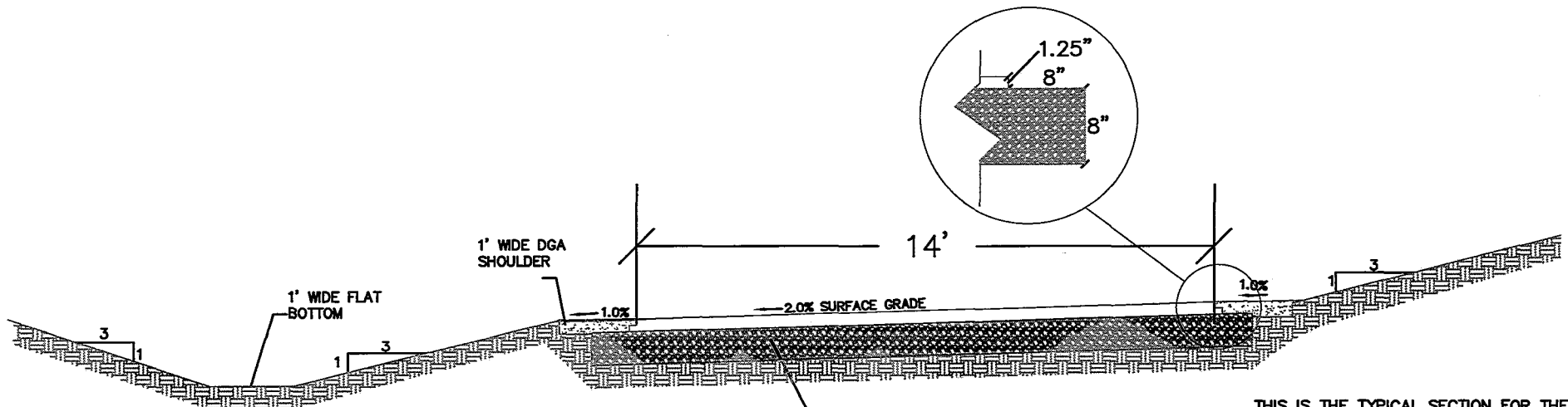

**FULL DEPTH RECLAMATION (FDR)**  
 1. SEE SHEET 3 FOR WHETHER OR NOT MATERIAL NEEDS TO BE IMPORTED, EXPORTED, OR IF THE EXISTING PAVEMENT IS SATISFACTORY FOR FDR.  
 2. EXISTING SUBGRADE COMPOSITION FOR EACH STREET IS PROVIDED ON SHEET 4.  
 3. FOR AREAS OF WIDENING THE EXISTING STREET, CONTRACTOR SHALL ADD APPROVED MATERIAL PRIOR TO PULVERIZATION.

**THIS IS THE TYPICAL SECTION FOR THE FOLLOWING STREETS:**

- ELM ROAD
- HEMLOCK ROAD
- IRVING ROAD
- LAKESIDE ROAD {SOUTH}
- FAIR VALLEY ROAD
- ASH ROAD
- HILLTOP ROAD
- WALNUT ROAD {PROPOSED}

#1D TYPICAL SECTION

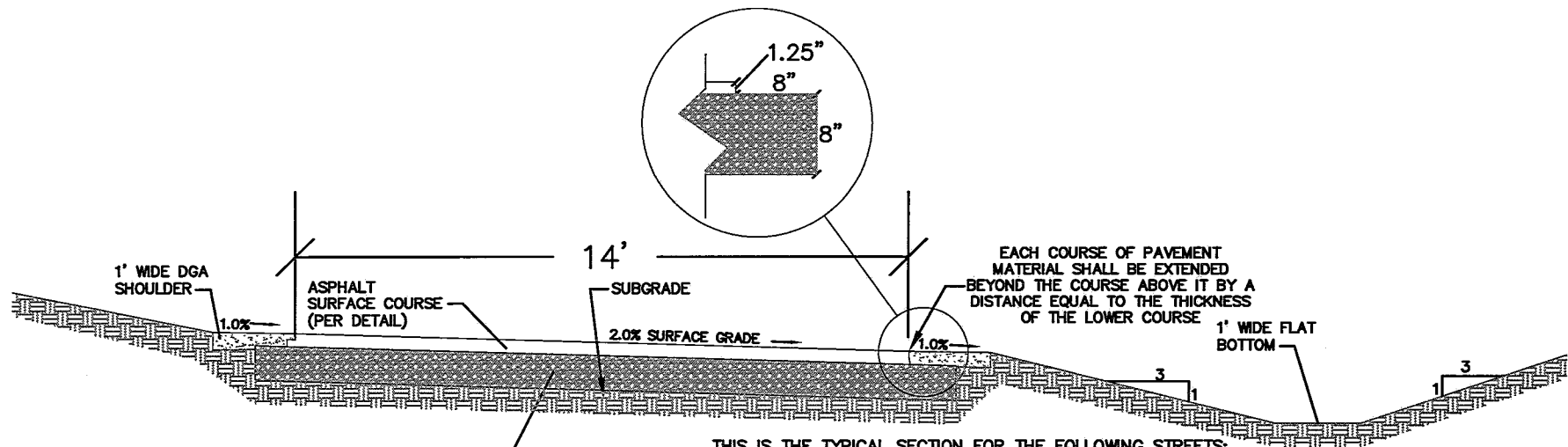

**FULL DEPTH RECLAMATION (FDR)**

1. SEE SHEET 3 FOR WHETHER OR NOT MATERIAL NEEDS TO BE IMPORTED, EXPORTED, OR IF THE EXISTING PAVEMENT THICKNESS IS SATISFACTORY FOR PROPOSED FDR.
2. EXISTING PAVEMENT COMPOSITION FOR EACH STREET IS PROVIDED ON SHEET 4.
3. FOR AREAS OF WIDENING THE EXISTING STREET, CONTRACTOR SHALL ADD APPROVED MATERIAL PRIOR TO PULVERIZATION. SEE DETAIL #3.

**THIS IS THE TYPICAL SECTION FOR THE FOLLOWING STREETS:**

- TWIN LAKES DRIVE {NORTH}
- DOGWOOD ROAD
- FOREST ROAD
- JERICHO ROAD {STA. 2+50 TO STA. 8+69}
- OAK ROAD
- LAKESIDE DRIVE (NORTH) {STA. 2+00 TO 10+71}
- CEDAR ROAD STA. 0+00 TO GROVE ROAD STA. 6+00
- WALNUT ROAD
- END OF CLUBHOUSE DRIVE {STA. 0+00 TO STA. 0+78}

#1E TYPICAL SECTION

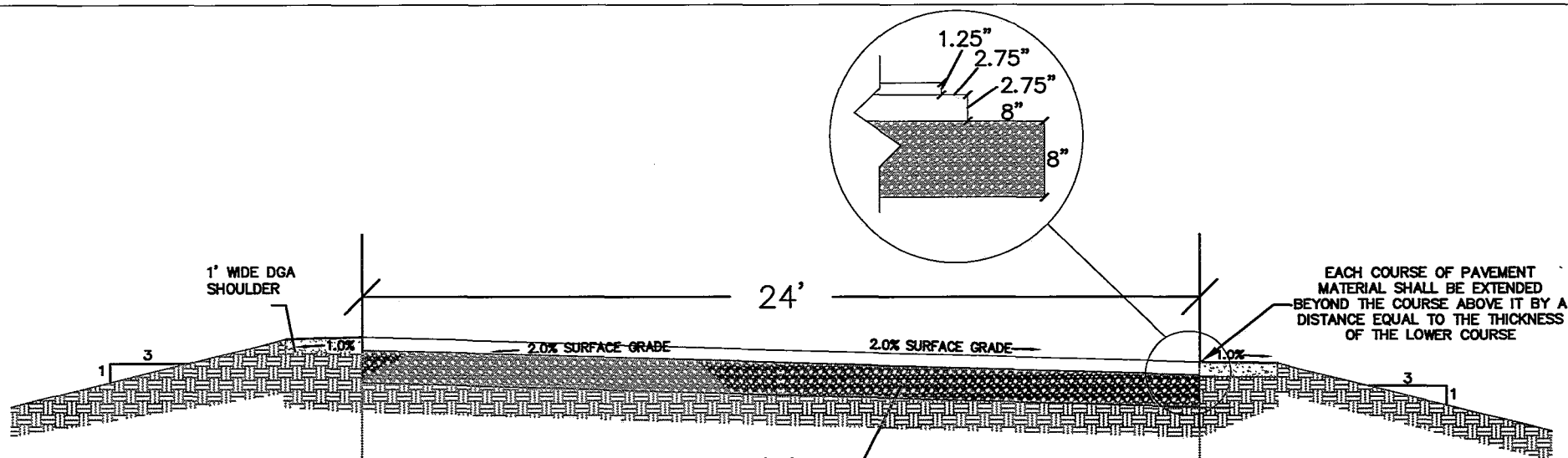

- FULL DEPTH RECLAMATION (FDR)**
1. SEE SHEET 3 FOR WHETHER OR NOT MATERIAL NEEDS TO BE IMPORTED, EXPORTED, OR IF THE EXISTING PAVEMENT IS SATISFACTORY FOR FDR.
  2. EXISTING SUBGRADE COMPOSITION FOR EACH STREET IS PROVIDED ON SHEET 4.
  3. FOR AREAS OF WIDENING THE EXISTING STREET, CONTRACTOR SHALL ADD APPROVED MATERIAL PRIOR TO PULVERIZATION.

THIS IS THE TYPICAL SECTION FOR THE FOLLOWING STREETS:  
 • CLUBHOUSE DRIVE {STA. 15+00 - STA. 24+00}

#1F TYPICAL SECTION



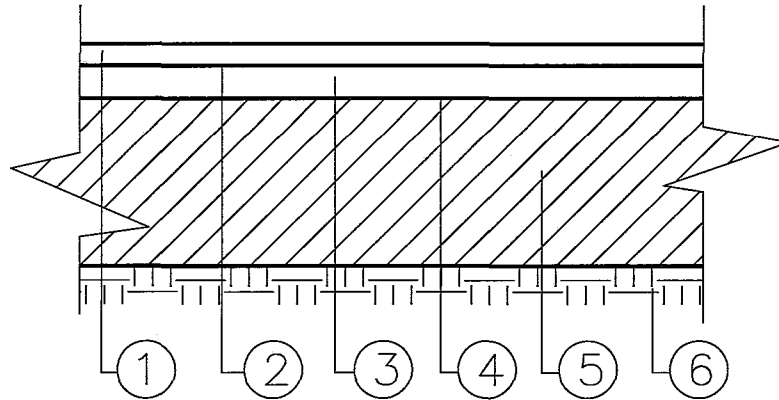

- ① 1 $\frac{1}{4}$ " CL2 ASPH SURF 0.38D PG64-22; KYTC SECTION 806
- ② BITUMINOUS TACK COAT (SS-1) @ 0.05 GAL/SY BETWEEN ALL ASPHALT LIFTS
- ③ 2 $\frac{3}{4}$ " CL2 ASPH BASE 0.75D PG64-22; KYTC SECTION 806
- ④ ASPHALT CURING SEAL (SS-1) @ 2 LBS/SY (KYTC SECTION 208)
- ⑤ FULL DEPTH RECLAMATION (FDR) – FOR MIX DESIGN, SEE SHEETS 3 & 4
- ⑥ UNDISTURBED SUBGRADE

**#2A**

## PAVEMENT DESIGN: CLUBHOUSE DRIVE

SCALE: N.T.S.

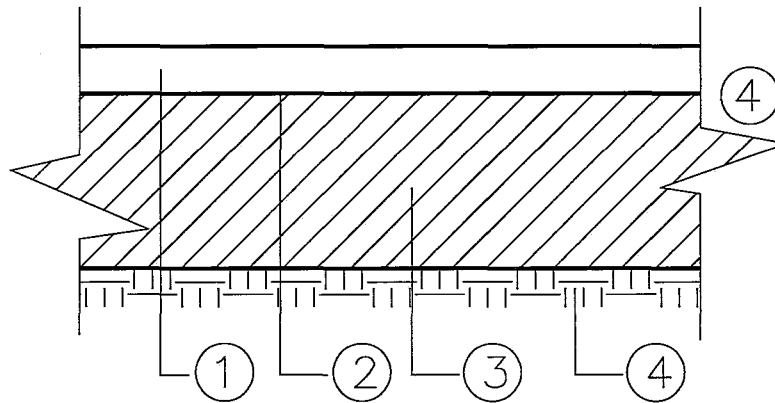

- ① 1 $\frac{1}{4}$ " CL2 ASPH SURF 0.38D PG64-22; KYTC SECTION 806
- ② ASPHALT CURING SEAL (SS-1) @ 2 LBS/SY (KYTC SECTION 208)
- ③ FULL DEPTH RECLAMATION (FDR) – FOR MIX DESIGN, SEE SHEETS 3 & 4
- ④ UNDISTURBED SUBGRADE

#2B

## PAVEMENT DESIGN: ALL 14' STREETS

SCALE: N.T.S.

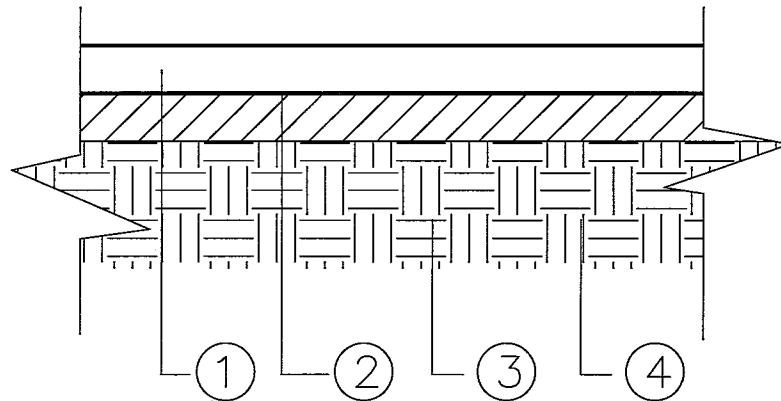

- ① 2" CL2 ASPH SURF 0.75D PG64-22
- ② BITUMINOUS TACK COAT (SS-1) @ 0.05 GAL/SY
- ③ EXISTING BIRCH STREET (ASPHALT)
- ④ UNDISTURBED SUBGRADE

#2C

## PAVEMENT DESIGN: ASPHALT OVERLAY

SCALE: N.T.S.

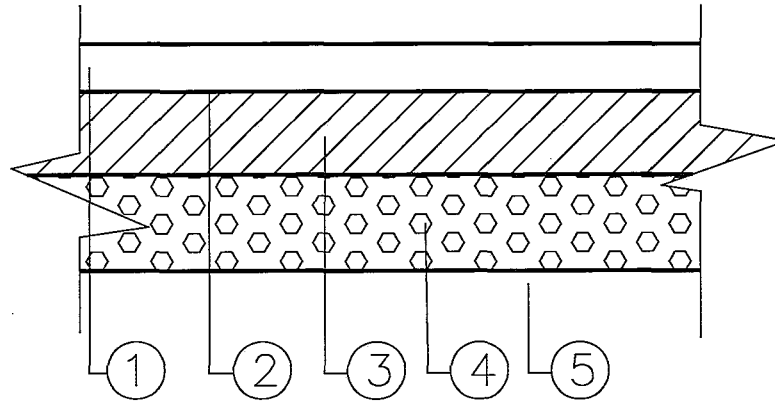

- ① 1 $\frac{1}{4}$ " CL2 ASPH SURF 0.38D PG64-22; KYTC SECTION 806
- ② BITUMINOUS TACK COAT (SS-1) @ 0.05 GAL/SY
- ③ 3" CL2 ASPH BASE 0.75D PG64-22; KYTC SECTION 806
- ④ 4" DGA BASE
- ⑤ COMPACTED SUBGRADE

**#2D**

# PAVEMENT DESIGN: ALL PROPOSED STREETS & TURNAROUNDS

SCALE: N.T.S.

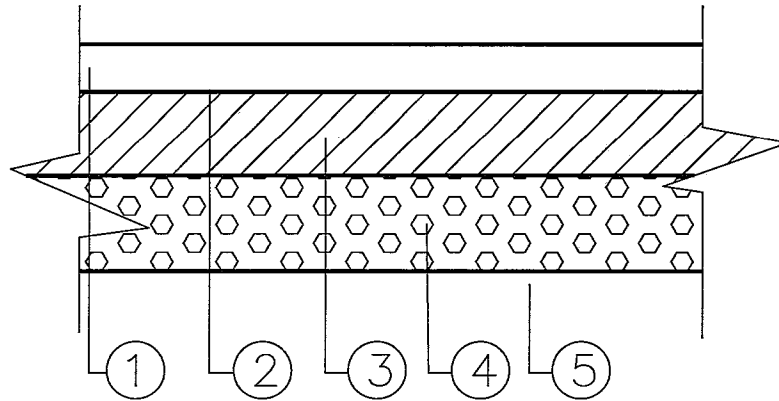

- ① 1 $\frac{1}{4}$ " CL2 ASPH SURF 0.38D PG64-22; KYTC SECTION 806
- ② BITUMINOUS TACK COAT (SS-1) @ 0.05 GAL/SY
- ③ 5" CL2 ASPH BASE 0.75D PG64-22; KYTC SECTION 806
- ④ 5" DGA BASE
- ⑤ COMPACTED SUBGRADE

#2E

## PAVEMENT DESIGN: PROPOSED CLUBHOUSE DIGOUT (STA. 1+00 TO STA. 1+80)

① EXCAVATION & PREPARATION

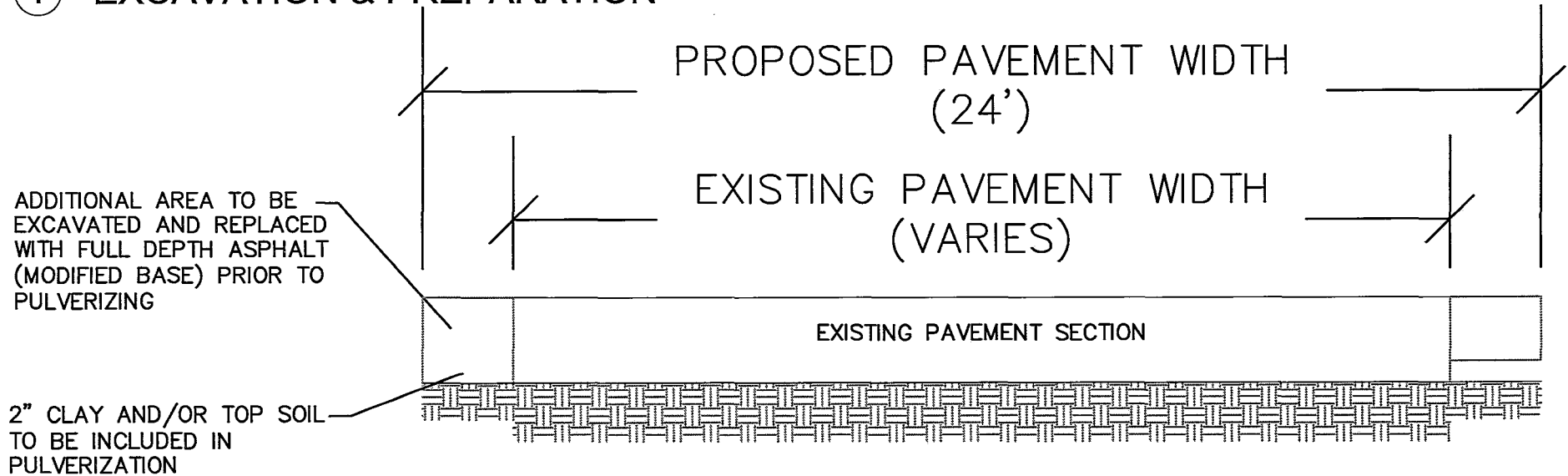

② PULVERIZATION AND FINAL SURFACE

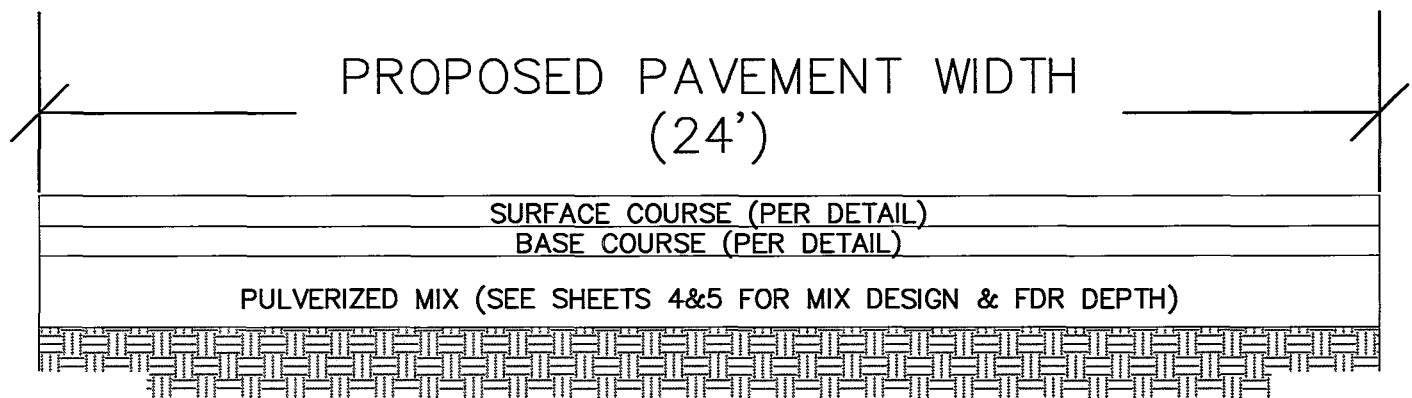

① EXCAVATION & PREPARATION

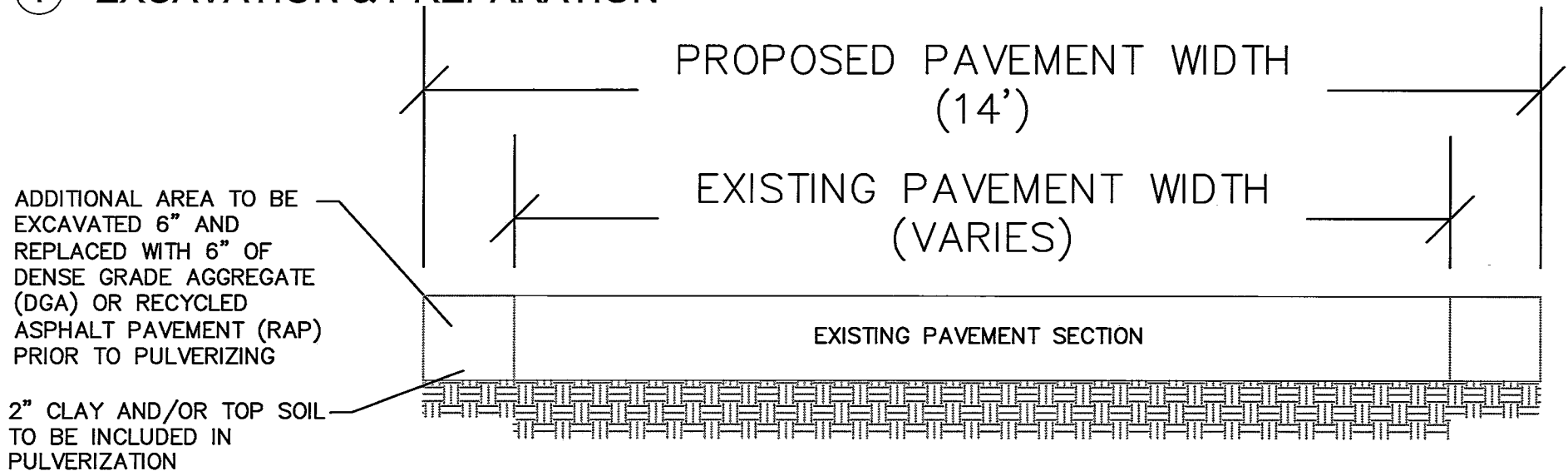

② PULVERIZATION AND FINAL SURFACE

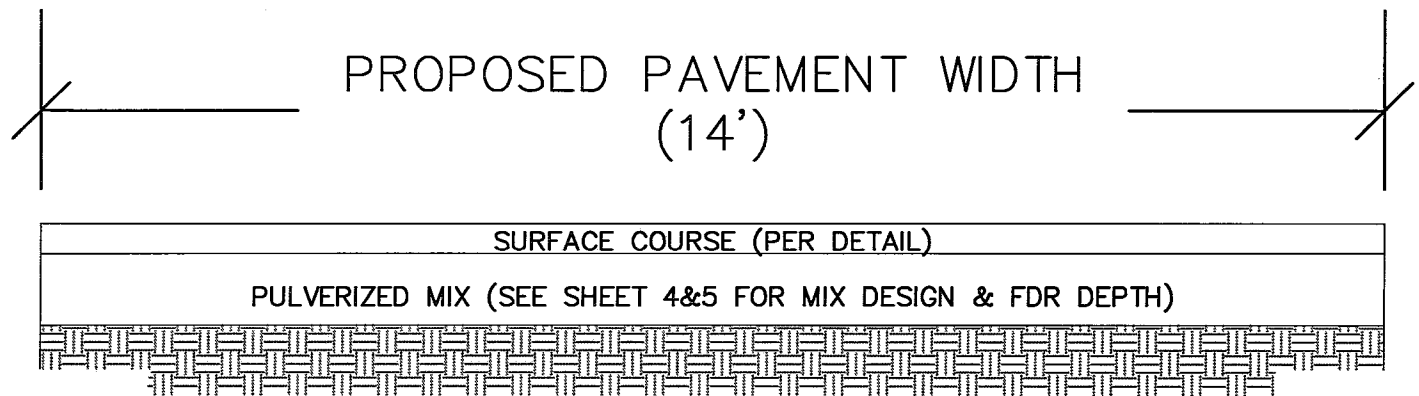

#3B PULVERIZING DETAIL FOR ADDITIONAL WIDTH AREAS - 14' STREETS

SCALE: N.T.S.

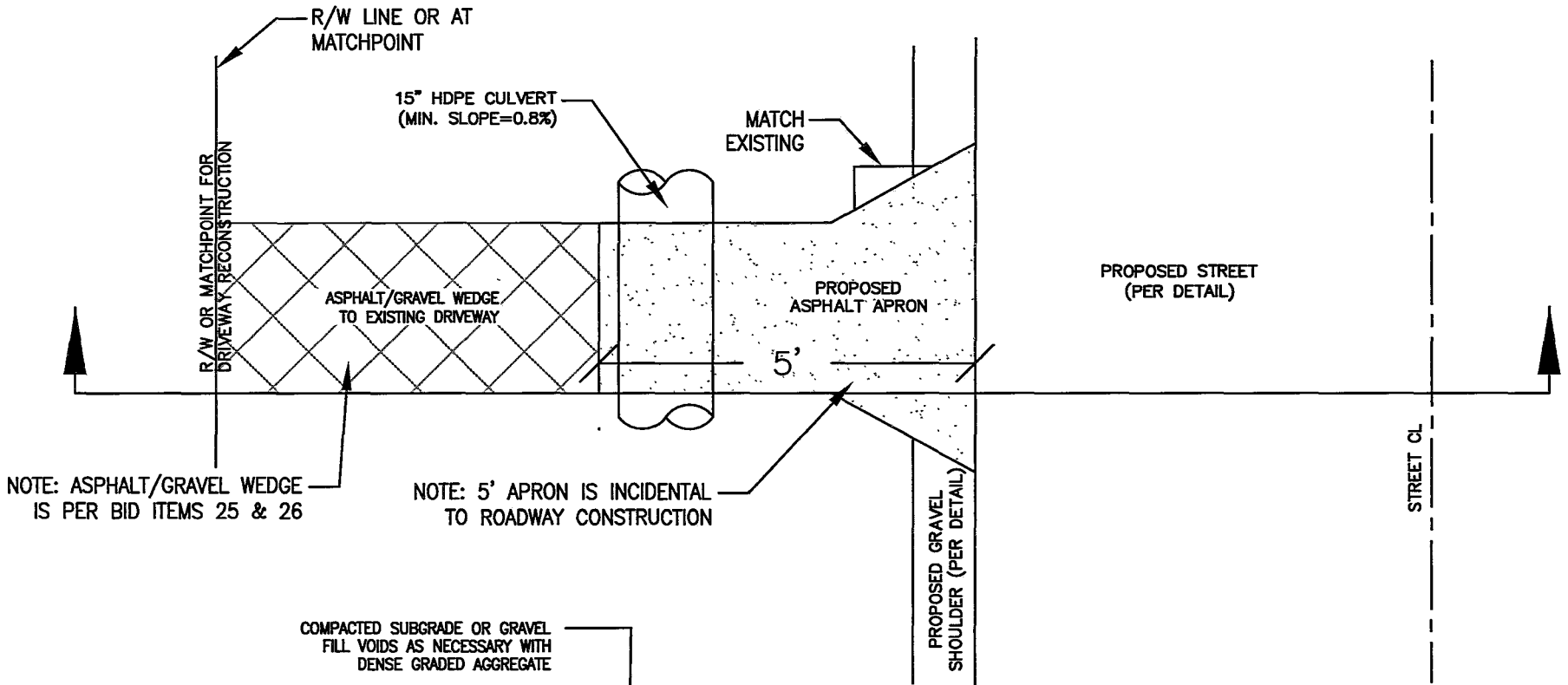

NOTE: ASPHALT/GRAVEL WEDGE IS PER BID ITEMS 25 & 26

NOTE: 5' APRON IS INCIDENTAL TO ROADWAY CONSTRUCTION

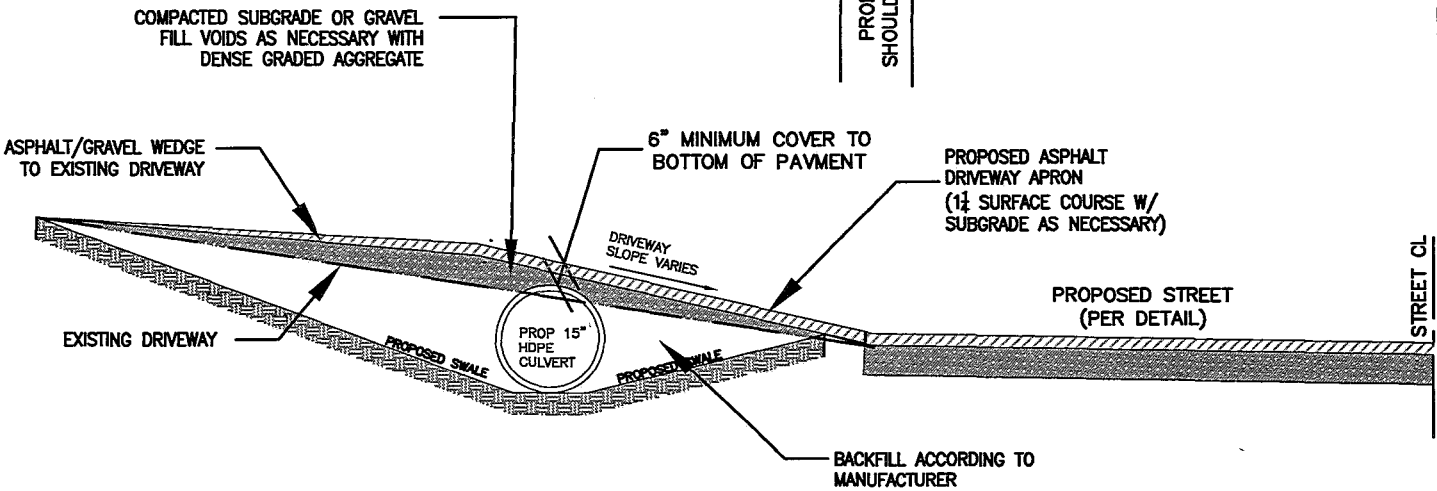

NOTE: REMOVE EXISTING CULVERTS AS NOTED ON PLANS

**#4A** DRIVEWAY RECONSTRUCTION ON DITCH SIDE WITH PROPOSED CULVERT

SCALE: N.T.S.



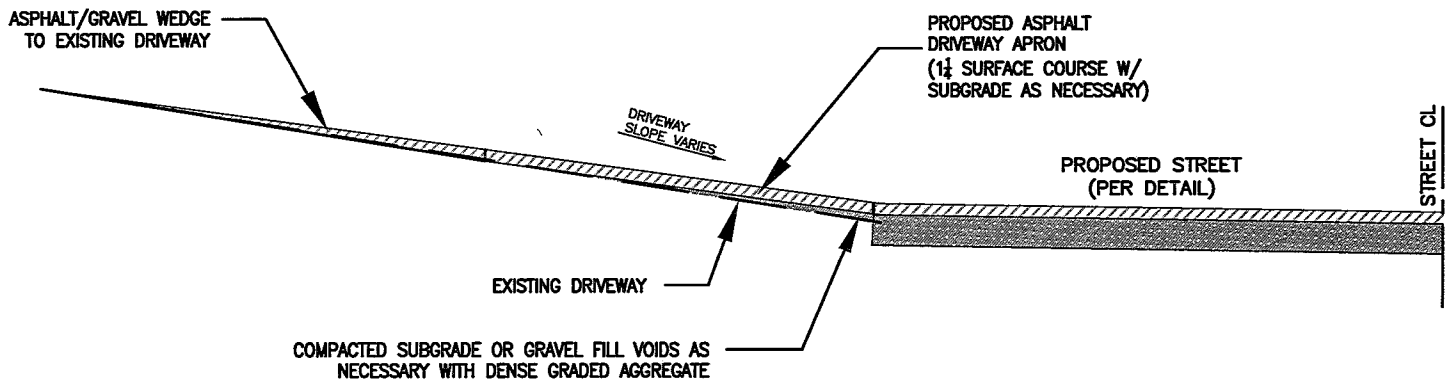
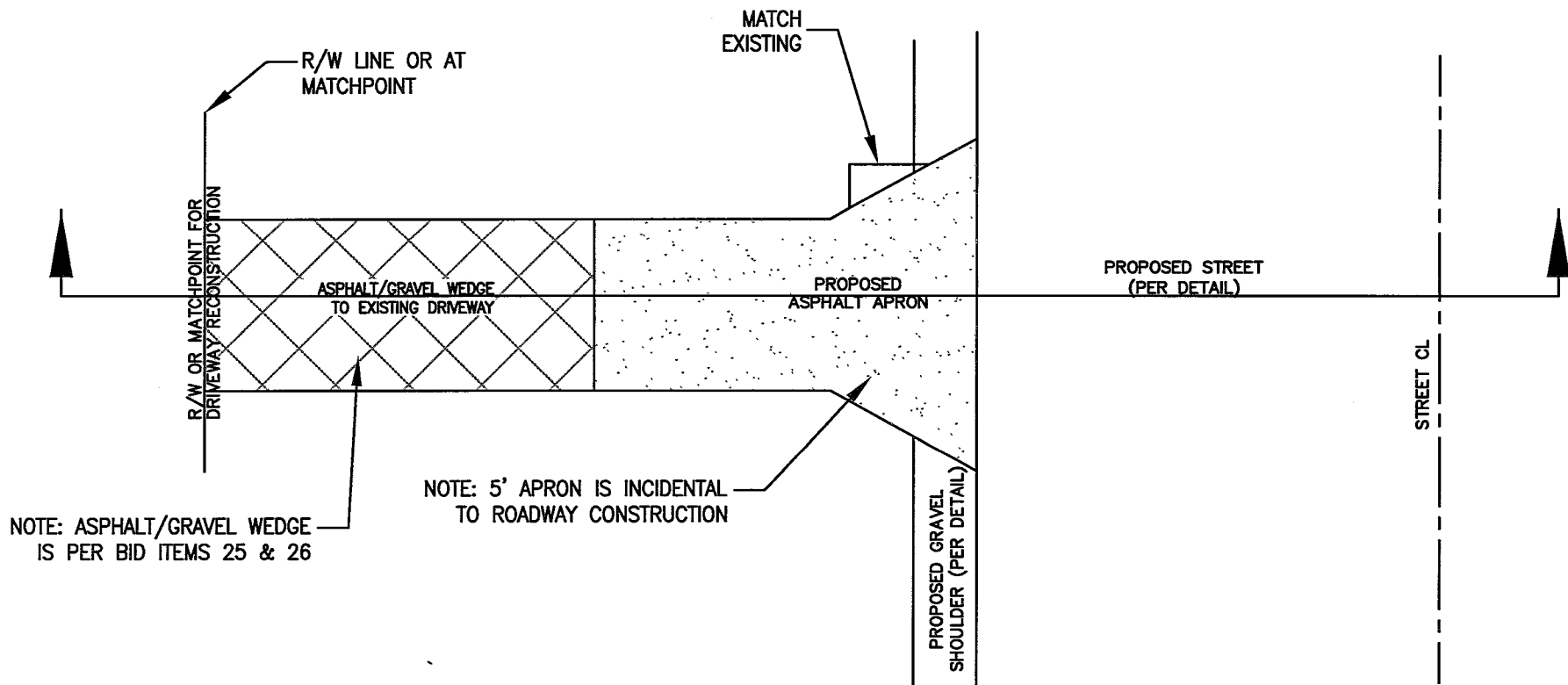

**#4B** DRIVEWAY RECONSTRUCTION ON NON-DITCH SIDE

SCALE: N.T.S.

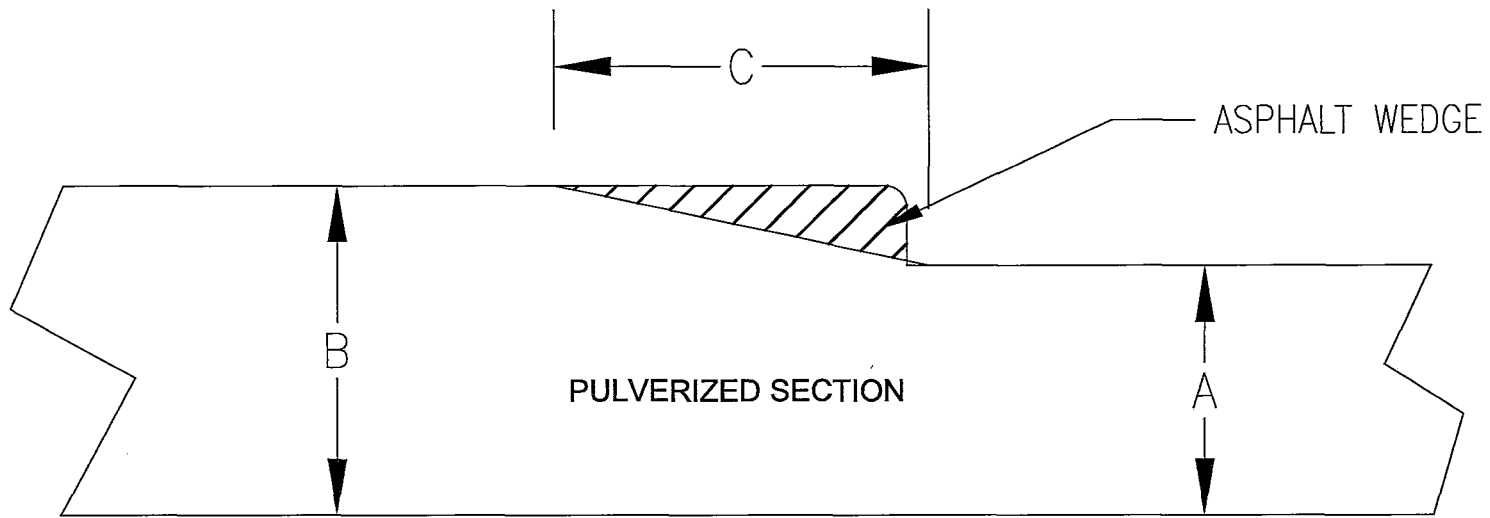
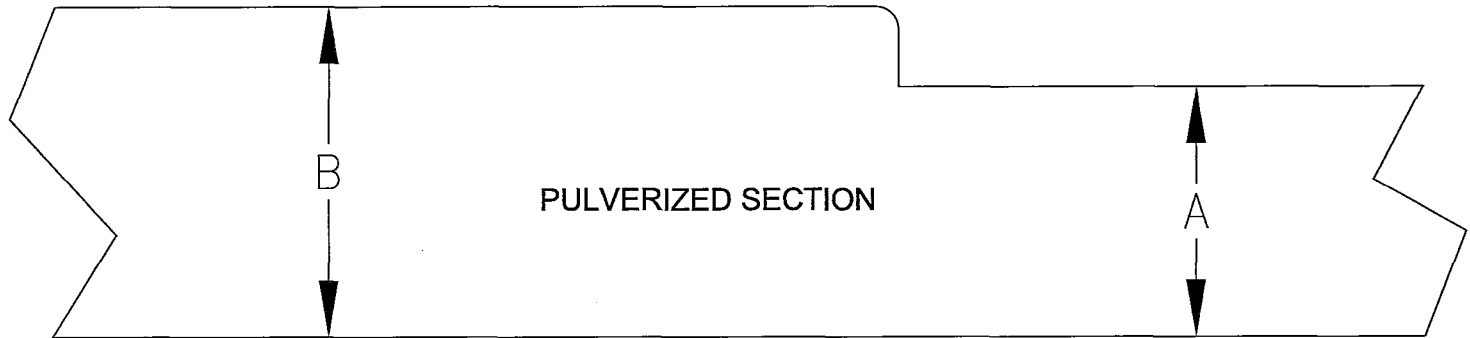

A - DEPTH OF FIRST FDR SECTION  
 B - DEPTH OF DEEPER FDR SECTION  
 C - USE 15' PER 1" DIFFERENCE BETWEEN B & A

① EXISTING CONDITION

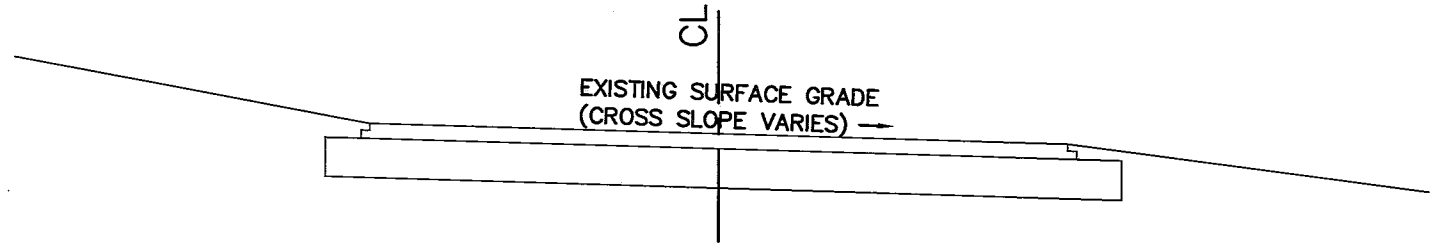

② MODIFIED BASE WEDGE

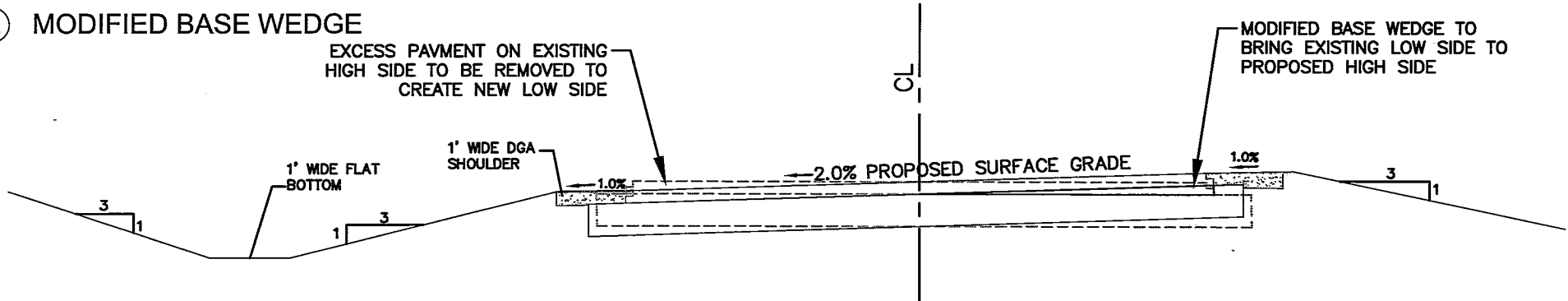

#6 CROSS-SLOPE FLIP w/ MODIFIED BASE WEDGE

East Coast ECSC-2 Erosion Control Blanket or equivalent installed to manufacturers specifications

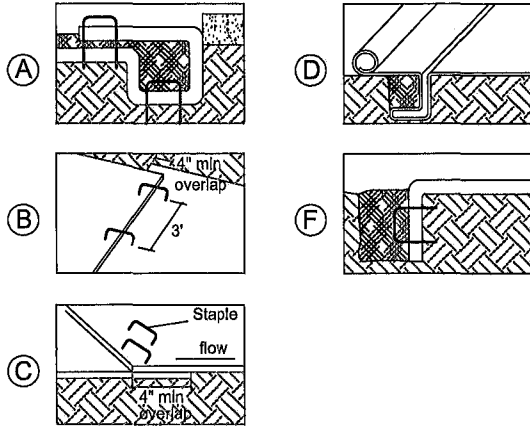

Technical Specifications for equivalent product:

- Top Net - Heavyweight UV-stabilized polypropylene
- Straw/Coconut Matrix - 70% agricultural straw (0.38 lbs/---/yd<sup>2</sup>)  
30% coconut (0.17 lbs/yd<sup>2</sup>)
- Bottom Net - Lightweight photodegradable polypropylene
- Thread must be degradable
- Permissible Shear Stress - 2.6 psf minimum
- For specified use in moderate to heavy flow drainage channels
- Provide a minimum of 24 months of erosion protection

\*Equivalent materials must be approved by owner and/or engineer.

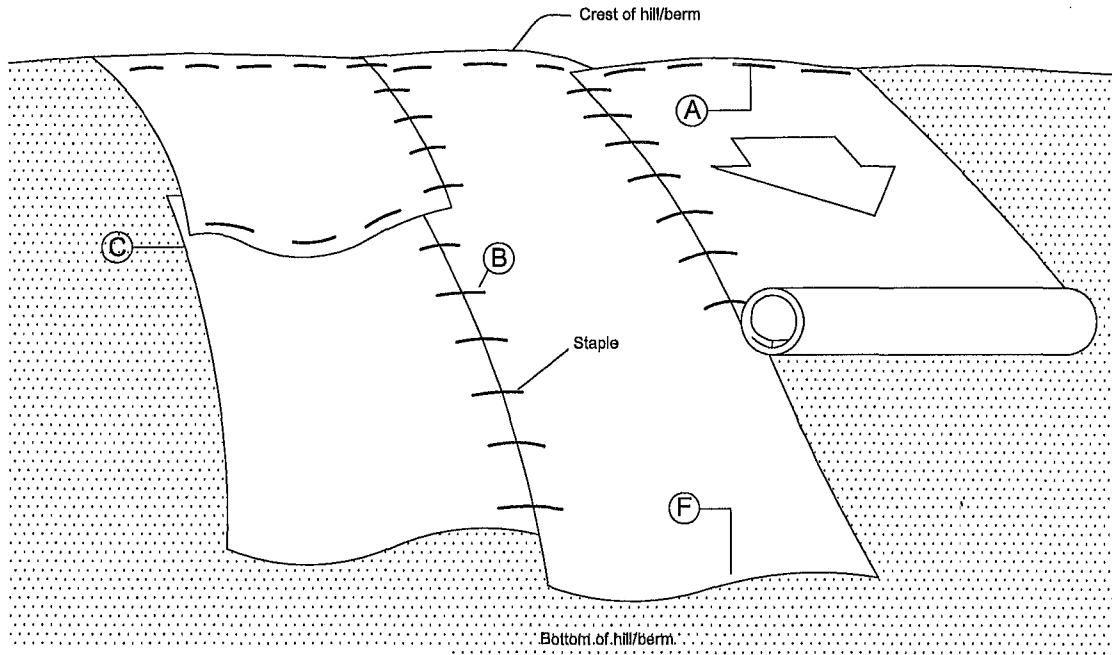

11/12/09

# EROSION CONTROL BLANKET

BASIC INSTALLATION GUIDE

SCALE: N.T.S.

REVISION

BY DATE

SANITATION DISTRICT NO. 1

DATE

1045 Eaton Drive  
 FT. Wright, Kentucky 41017

AUG 2009

Ph: (859) 578-7460

Fax: (859) 331-2436

STANDARD DRAWING NO:

STM-08

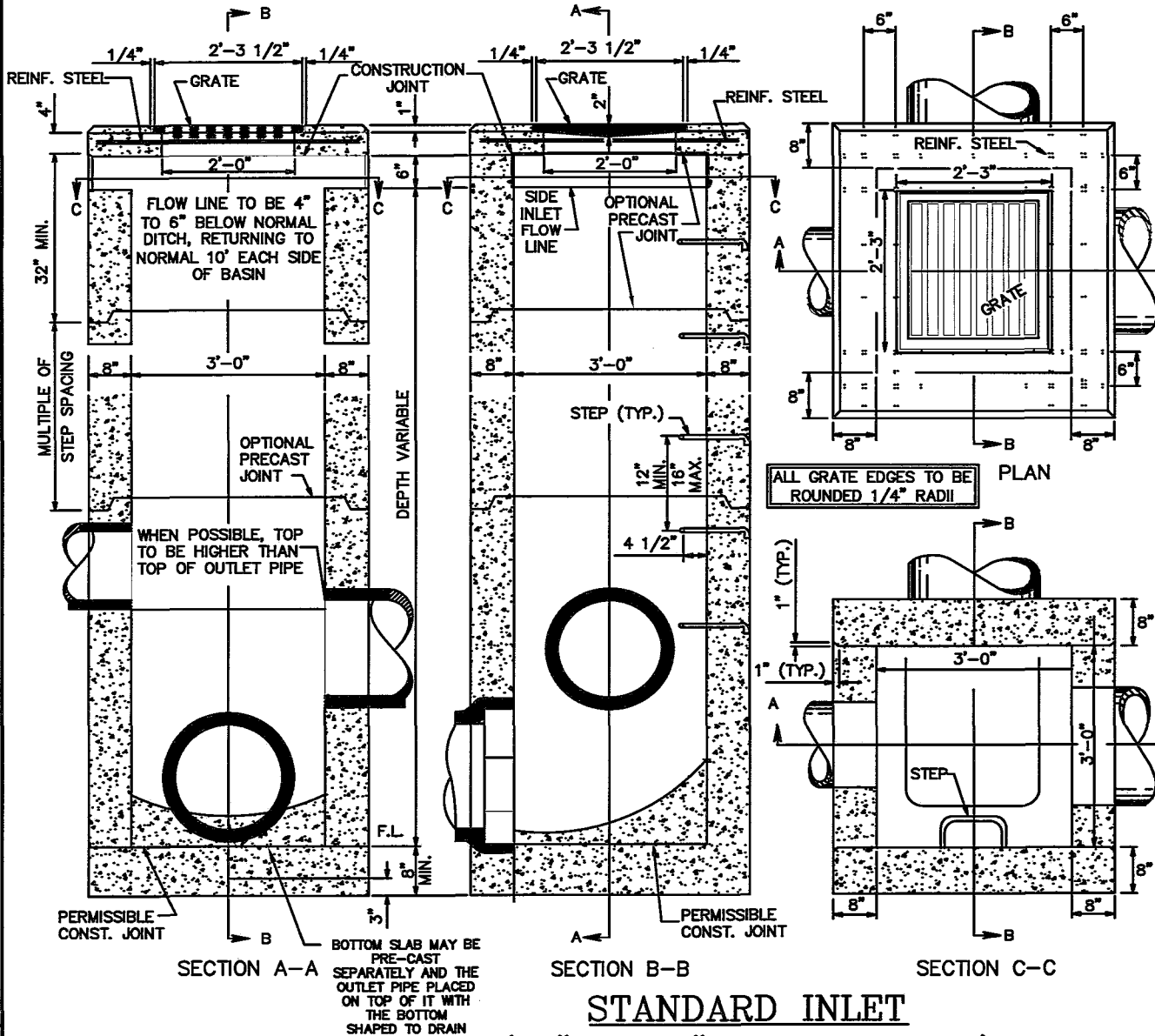

**STANDARD INLET**  
**(12" - 33" OUTLET PIPE)**  
**(STM-08)**

N.T.S.

(REFERENCE - ODOT CB 1.2 - {2-3})

**KNOCKOUT PANELS:** IF STRUCTURES WITH KNOCK OUT PANELS ARE USED AT DEPTHS GREATER THAN 6' STRUCTURAL CALCULATIONS MUST BE SUPPLIED

- NOTES -

**GRATES:**  
 GRATES SHALL BE NEENAH NO. R-4850-C OR EAST JORDAN NO. 5110 TYPE M2 OR APPROVED EQUALS.

**WALLS:** CAST-IN-PLACE WALLS SHALL HAVE A NOMINAL THICKNESS OF 8". PRECAST WALLS SHALL HAVE A MINIMUM THICKNESS OF 6" AND BE REINFORCED SUFFICIENTLY TO PERMIT SHIPPING AND HANDLING WITHOUT DAMAGE. CONCRETE SHALL MEET REQUIREMENTS OF SD1'S SPECIFICATIONS, SECTION 02630, PARAGRAPH 3.1.1.

**REINFORCEMENT:** REINFORCING IN THE TOP IS TO BE #4 BARS SPACED AT 6" CENTER TO CENTER. USE EIGHT BARS.

**INLETS OVER 12 FEET IN DEPTH:** SHALL BE PRECAST OR CAST-IN PLACE CONCRETE; REINFORCED WITH #4 BARS ON 12" CENTERS BOTH VERTICALLY AND HORIZONTALLY WITH 2" CLEARANCE FROM INSIDE WALL FACE.

**PRECAST BASE:** IF A PRECAST BASE IS USED, IT SHALL BE SET DEEP ENOUGH SO THAT THE TOP CAN BE PLACED ON THE BASE TO PROVIDE THE GRATE ELEVATION SPECIFIED IN THE PLANS. GRADE ADJUSTMENTS SHALL BE MADE PER SD1'S SPECIFICATION SECTION 02630, SECTION 3.2.4 AND 3.2.5. CONCRETE SHALL MEET REQUIREMENTS OF SD1'S SPECIFICATIONS, SECTION 02630, PARAGRAPH 3.1.1.

**LOCATION AND ELEVATION:** WHEN GIVEN ON THE PLANS, THE LOCATION AND THE ELEVATION ARE AT THE TOP CENTER OF THE GRATE. WHEN SIDE OPENINGS ARE PROVIDED, THE ELEVATION SHALL BE AT THE FLOW LINE OF THE SIDE INLET.

**MINIMUM DEPTH:** THE MINIMUM DEPTH SHALL BE THE OUTSIDE DIAMETER (O.D.) OF THE OUTLET PIPE PLUS 7".

**OPENINGS:** PIPE OPENINGS SHALL BE THE O.D. OF THE PIPE BEING SUPPLIED PLUS 3" WHEN PREFABRICATED OR FIELD CUT. THE INTERSTITIAL SPACE SHALL BE FILLED WITH GROUT.

**SIDE INLETS:** SHALL BE PROVIDED ONLY WHEN SPECIFIED ON THE PLANS.

**STEPS:** STEPS SHALL BE PROVIDED WHERE THE DEPTH EXCEEDS 4' AND SHALL MEET THE REQUIREMENTS OF SD1'S SPECIFICATIONS, SECTION 02630, PARAGRAPH 3.2.2.

**BENCHING:** BENCHING SHALL BE REQUIRED IN ALL STRUCTURES AND SHALL MEET THE REQUIREMENTS OF SECTION 02630, PARAGRAPH 3.2.3, OF SD1'S STANDARD SPECIFICATIONS

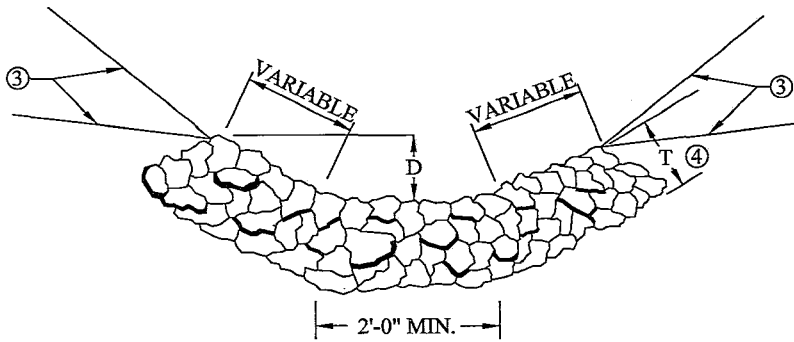
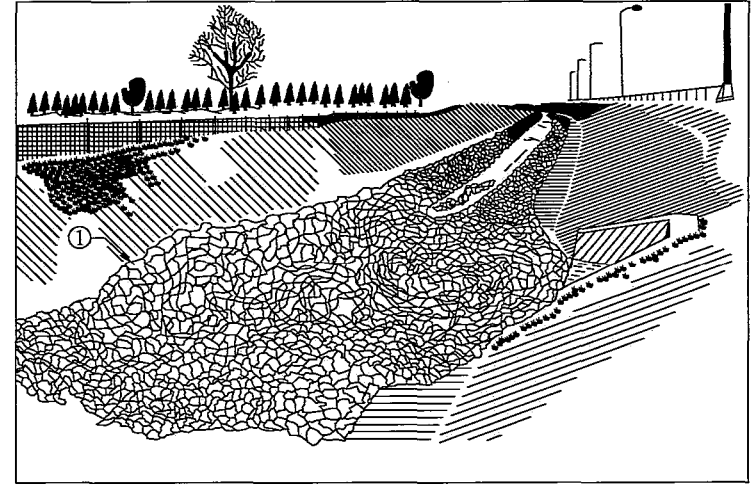
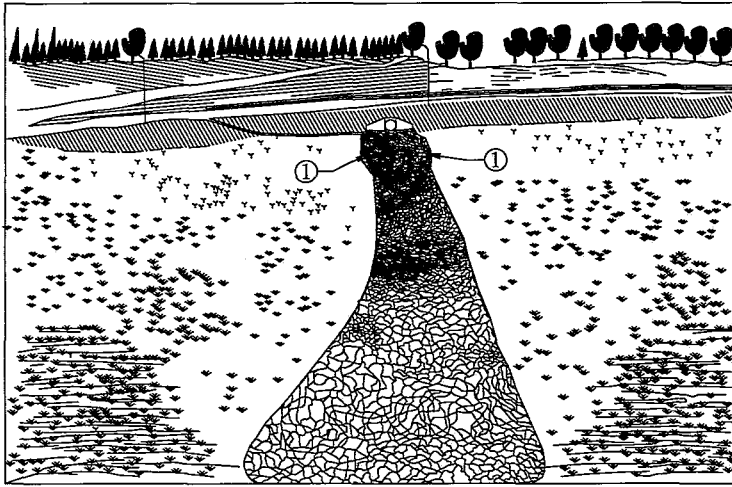

TYPICAL SECTION

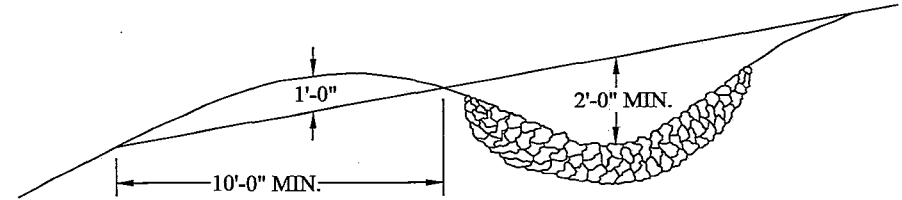

TYPICAL INTERCEPTOR DITCH

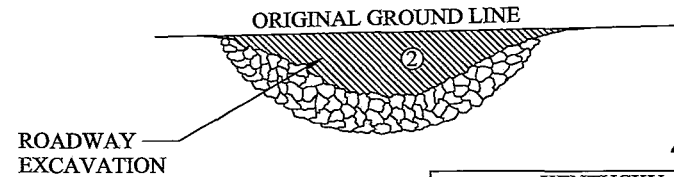

NOTES

- CHANNEL LINING WILL BE PAID FOR AT THE CONTRACT UNIT PRICE PER TON FOR EACH CLASS.  
 CHANNEL LINING WILL NOT BE REQUIRED IN THE BOTTOM OF THE DITCH WHERE SOLID ROCK IS ENCOUNTERED.  
 CHANNEL LINING ESTIMATED ON THE BASIS OF 0.50 TON PER SQ. YD. PER FOOT OF DEPTH.
- ① WIDEN CHANNEL LINING NEAR OUTLET END OF STRUCTURE AS DIRECTED BY THE ENGINEER.
  - ② FROM THE TOP OF THE LINING TO THE ORIGINAL GROUNDLINE.
  - ③ ALTERNATE LOCATION OF GROUNDLINE.
  - ④ 15' MIN. CLASS II, OR 24' MIN. CLASS III.
- D=DEPTH TO PROJECT, T=THICKNESS, (SEE PLAN NOTES FOR THESE VALUES)

4/2/07

KENTUCKY  
DEPARTMENT OF HIGHWAYS

CHANNEL LINING  
CLASS II AND III

STANDARD DRAWING NO. RDD-040-04

SUBMITTED	12-1-99
DIRECTOR DIVISION OF DESIGN	DATE
APPROVED	12-1-99
STATE HIGHWAY ENGINEER	DATE

REVISION

BY DATE

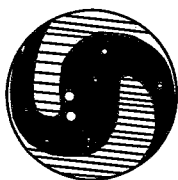

SANITATION DISTRICT NO. 1

1045 Eaton Drive  
 FT. Wright, Kentucky 41017  
 Ph: (859) 578-7460  
 Fax: (859) 331-2436

DATE: MAY 2010

STANDARD DRAWING NO.: STM-16

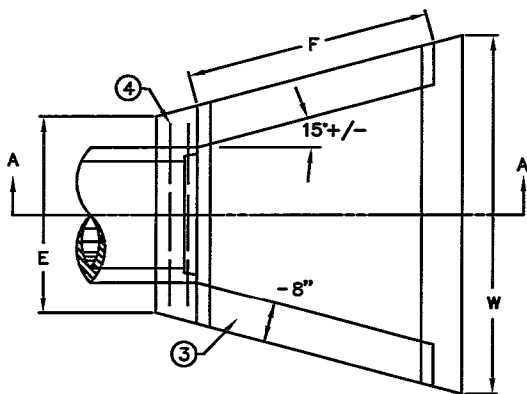

PLAN VIEW

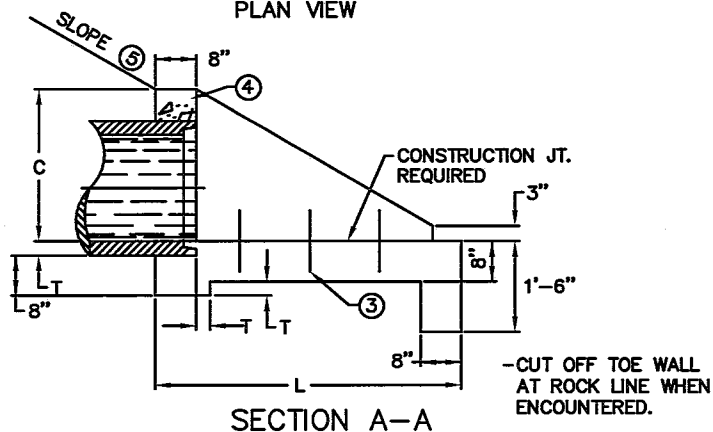

SECTION A-A

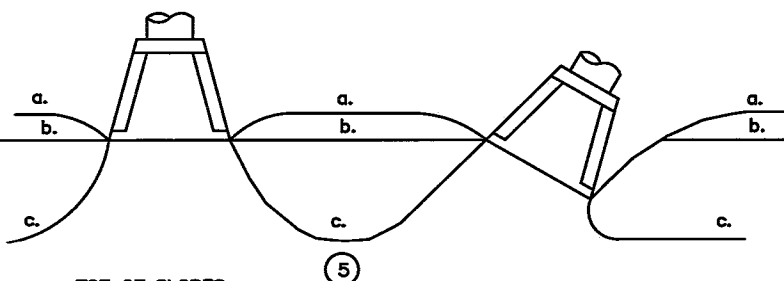

TOE OF SLOPES:  
 a. STEEPER THAN 2:1  
 b. 2:1  
 c. FLATTER THAN 2:1

PIPE DIA. OR EQUIV. DIA.	PIPE SHAPE ⑨	DIMENSIONS						CLASS A CONC C. Y.	REINF STEEL LBS.
		C	E	F	L	W	T		
12"	○	1'-9"	2'-6"	2'-3"	3'-6"	4'-0"	2"	0.58	7
15"	○	2'-0"	2'-9"	2'-9"	4'-0"	4'-9"	2 1/4"	0.75	
	○	1'-9"	3'-0"	2'-6"	3'-6"	4'-9"		0.68	
18"	○	2'-3"	3'-0"	3'-6"	4'-6"	5'-3"	2 1/2"	0.93	8
	○	2'-0"	3'-6"	3'-0"	4'-0"	5'-6"		0.89	
21"	○	2'-6"	3'-3"	4'-0"	5'-0"	6'-0"	2 3/4"	1.14	9
	○	2'-3"	3'-0"	3'-6"	4'-6"	6'-0"		1.07	
24"	○	2'-9"	3'-6"	4'-6"	5'-6"	6'-6"	3"	1.35	8
	○	2'-6"	4'-0"	4'-0"	5'-0"	6'-9"		3 1/4"	
27"	○	3'-0"	3'-9"	5'-0"	6'-0"	7'-0"	3 1/2"	1.57	10
	○	2'-9"	4'-6"	4'-3"	5'-3"	7'-3"		1.51	

NOTES

1. DIMENSIONS AND QUANTITIES ARE BASED ON CONCRETE PIPE AND WILL VARY INSIGNIFICANTLY FOR ALTERNATE PIPE MATERIALS.
2. REINFORCING STEEL : MINIMUM GRADE 40, BARS EVENLY SPACED.
- ③ 6 - NO. 4 x 1'-0" DOWEL BARS.
- ④ 2 - NO. 4 x (E DIMENSION MINUS 4").
- ⑤ SLOPES SHALL BE WARPED TO FIT HEADWALL WHEN PIPE IS SKEWED AND/OR NORMAL SLOPE VARIES FROM 2:1.
6. VOLUME DISPLACED BY PIPE COMPUTED USING INSIDE DIAMETER OF PIPE.
7. WING ANGLES AND/OR DIMENSIONS MAY BE ALTERED DURING CONSTRUCTION TO ACCOMMODATE FLOW OF WATER.
8. APRON BETWEEN WINGS SHALL BE SLOPED IN DIRECTION OF FLOW EQUAL TO SLOPE OF PIPE. FRONT FACE OF HEADWALL SHALL REMAIN VERTICAL.
- ⑨ HEADWALLS ARE FOR CIRCULAR, ARCH, AND HORIZONTAL ELLIPTICAL 12"- 27" EQUIVALENT PIPE SIZES. SEE CURRENT KDOT STD. DWG. RDI-016, FOR NON-CIRCULAR PIPE EQUIVALENT SIZES.
10. ENCLOSURE GRATE SHALL BE INSTALLED PER DETAIL STM-19 FOR PIPE SIZES 24 INCHES DIAMETER AND UNDER.

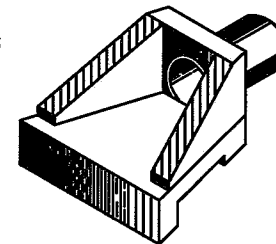

ISOMETRIC VIEW

SLOPED & FLARED HEADWALLS (12"-27" PIPE)

(STM-16)

N.T.S.

(REFERENCE KYTC STANDARD DRAWING RDH-020)

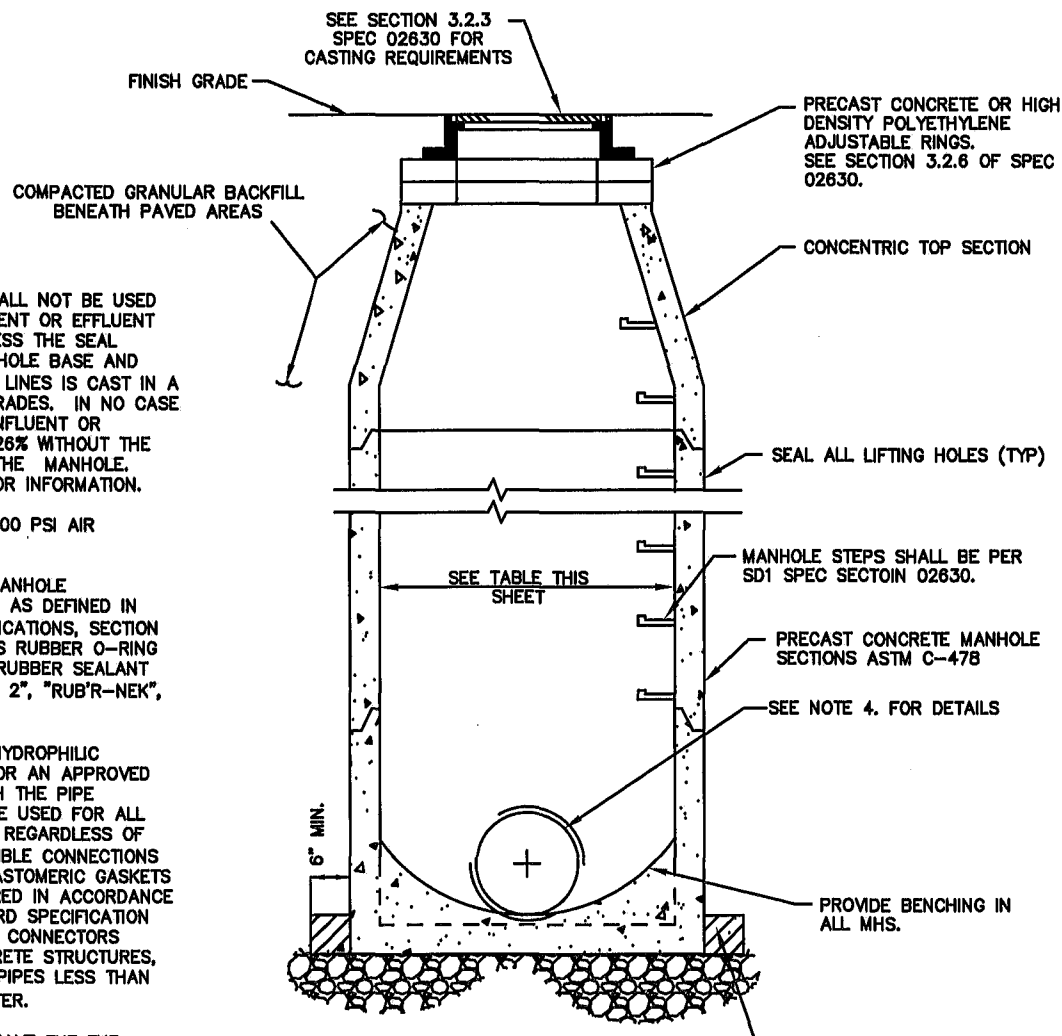

**NOTES:**

1. PRECAST MANHOLE BASE SHALL NOT BE USED IF THE GRADE OF THE INFLUENT OR EFFLUENT CONDUIT EXCEEDS 10%, UNLESS THE SEAL BETWEEN THE PRECAST MANHOLE BASE AND INFLUENT AND/OR EFFLUENT LINES IS CAST IN A SKEW TO ACCEPT LARGER GRADES. IN NO CASE SHALL THE GRADE OF THE INFLUENT OR EFFLUENT CONDUIT EXCEED 26% WITHOUT THE USE OF A FITTING OUTSIDE THE MANHOLE. SEE SPECIFICATION 02606 FOR INFORMATION.
2. ALL CONCRETE SHALL BE 4000 PSI AIR ENTRAINED.
3. JOINTS BETWEEN PRECAST MANHOLE SECTIONS SHALL BE SEALED AS DEFINED IN PART 3.2.4 OF SD1'S SPECIFICATIONS, SECTION 02630: A SINGLE, CONTINUOUS RUBBER O-RING GASKET, A FLEXIBLE BUTYL RUBBER SEALANT (CONSEAL), "KENT-SEAL NO. 2", "RUB'R-NEK", OR "E-Z STIK".
4. FLEXIBLE CONNECTIONS OR HYDROPHILIC SEALANT AND OKUM ROPE, OR AN APPROVED NON-BENTONITE EQUAL, WITH THE PIPE GROUTED IN PLACE SHALL BE USED FOR ALL CONNECTIONS AT MANHOLES REGARDLESS OF THE PIPE'S DIAMETER. FLEXIBLE CONNECTIONS AT MANHOLES SHALL BE ELASTOMERIC GASKETS OR COUPLINGS, MANUFACTURED IN ACCORDANCE WITH ASTM C 1478, STANDARD SPECIFICATION FOR STORM DRAIN RESILIENT CONNECTORS BETWEEN REINFORCED CONCRETE STRUCTURES, PIPES, AND LATERALS. FOR PIPES LESS THAN OR EQUAL TO 48" IN DIAMETER.
5. THE PRECAST BASE SHALL HAVE THE FLOOR AND SIDE WALL CAST AS ONE UNIT; IF THE FLOW LINE (CHANNEL) AND BENCHES ARE NOT CAST AS A PART OF FLOOR AND SIDE WALL, THEY SHALL BE CAST IN PLACE.
6. LIFT HOLES IN PRECAST MANHOLE BASE TO BE SEALED WITH HYDRAULIC CEMENT.
7. PRECAST MANHOLES SHALL BE INSTALLED PER SECTION 02606.
8. BENCHING SHALL BE SHAPED TO MAINTAIN A SMOOTH TRANSITION OF FLOW FOR PIPE ANGLES BETWEEN 90 AND 180 DEGREES, AS REFERENCED TO THE DOWNSTREAM FLOWLINE. NO ANGLES LESS THAN 90 DEGREES WILL BE ALLOWED BETWEEN INCOMING AND OUTGOING PIPES IN MHS.
9. ALL MANHOLES SHALL FOLLOW THE REQUIREMENTS OF SECTION 02630 OF SD1'S TECHNICAL SPECIFICATIONS.
10. FOR LARGE DIAMETER MANHOLES GREATER THAN 5'-0" DIAMETER, THE BOTTOM SECTION CAN TRANSITION WITH REDUCER SLAB TO A 4'-0" DIAMETER SECTION AND CONE. THE REDUCER SHALL BE AT LEAST 2'-0" ABOVE THE CROWN OF THE HIGHEST INCOMING PIPE.

PIPE DIAMETER	MH BASE ID
12" THRU 21"	48"
24" THRU 36"	60"
42" & 48"	72"
60"	90"
72"	108"

**STANDARD MANHOLE**  
N.T.S.

REVISION	BY	DATE



**SANITATION DISTRICT NO. 1**  
1045 Eaton Drive  
FT. Wright, Kentucky 41017  
Ph: (859) 578-7460  
Fax: (859) 331-2436

**DATE:**  
MAY 2010

**STANDARD DRAWING NO:**  
**STM-13**



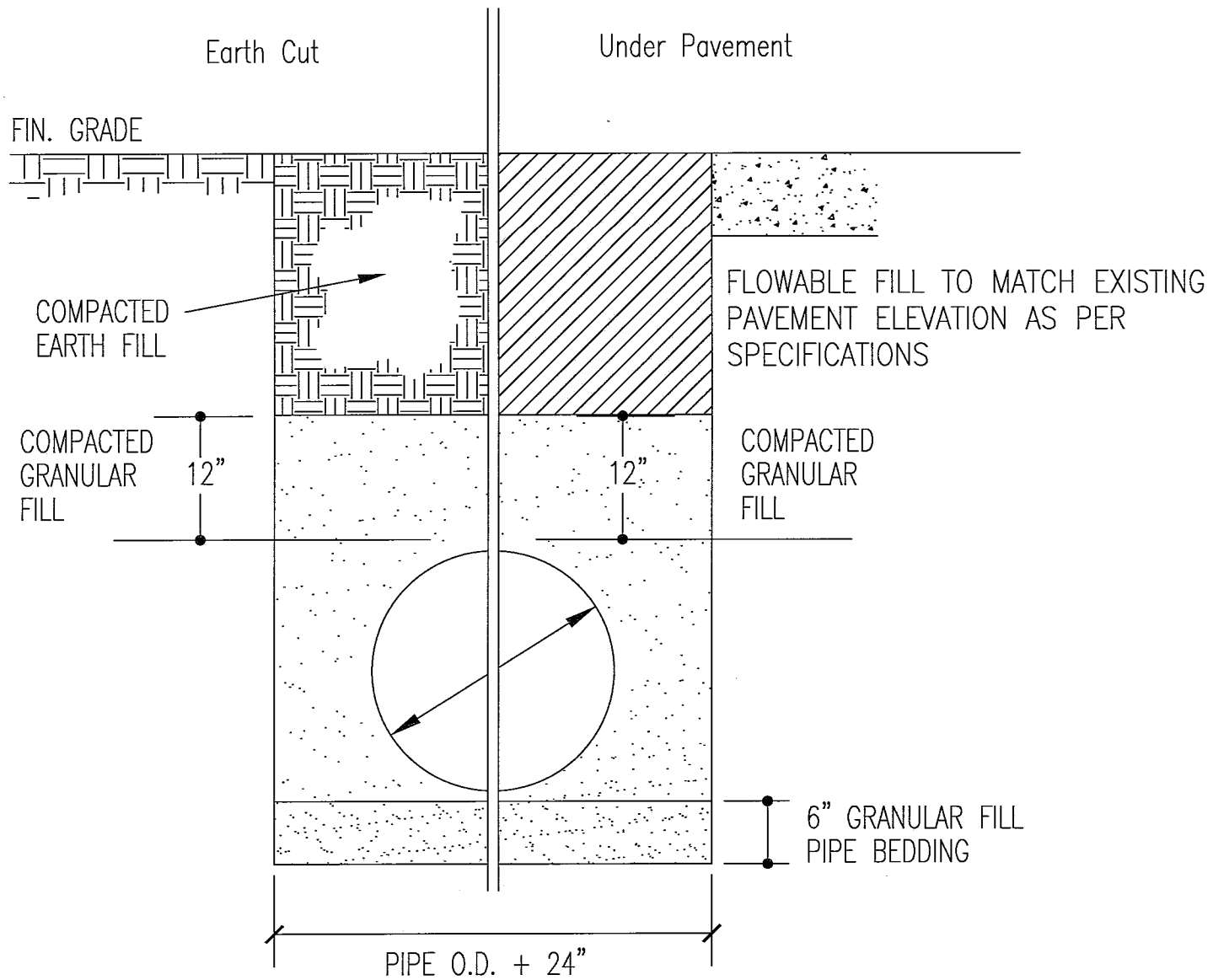

# TRENCH DETAIL

COUNTY OF	ITEM NO.	SHEET NO.

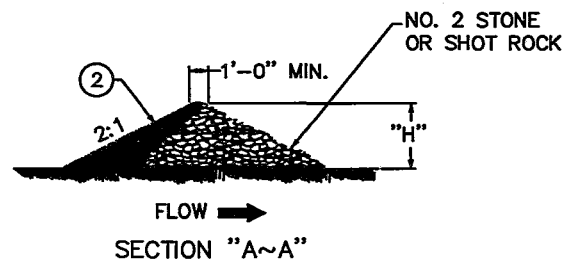
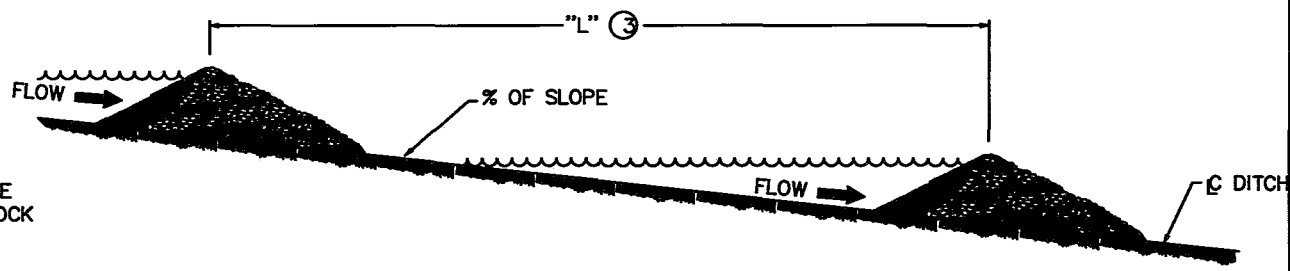
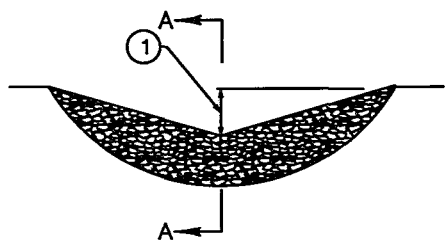

~NOTES~

BID ITEM AND UNIT TO BID:

CODE	PAY ITEM	PAY UNIT
2704	SILT TRAP TYPE B	EACH
2707	CLEAN SILT TRAP TYPE B	EACH

- ① MIDDLE OF SILT TRAP SHALL BE A MINIMUM OF 1'-0" LOWER THAN SIDES SO FLOW WILL NOT BYPASS TRAP OR ERODE BANKS.
- ② UPSTREAM FACE OF SILT TRAP SHALL BE A FOUR INCH MIN. LAYER OF CRUSHED AGGREGATE HAVING 100% PASSING A 3" SIEVE AND NO MORE THAN 5% PASSING A NO. 8 SIEVE (SEE SECTION "A-A").
- ③ "L" =  $\frac{H}{\text{SLOPE OF DITCH}}$
- ④ SPACE SILT TRAPS AT LOCATIONS AS SHOWN ON THE PLANS OR AS DIRECTED BY THE ENGINEER.
5. SILT TRAP TYPE B SHALL BE USED ON ALL SLOPES GREATER THAN 2%.
6. SILT TRAP TYPE B MAY BE USED ON ALL SLOPES LESS THAN 2%.

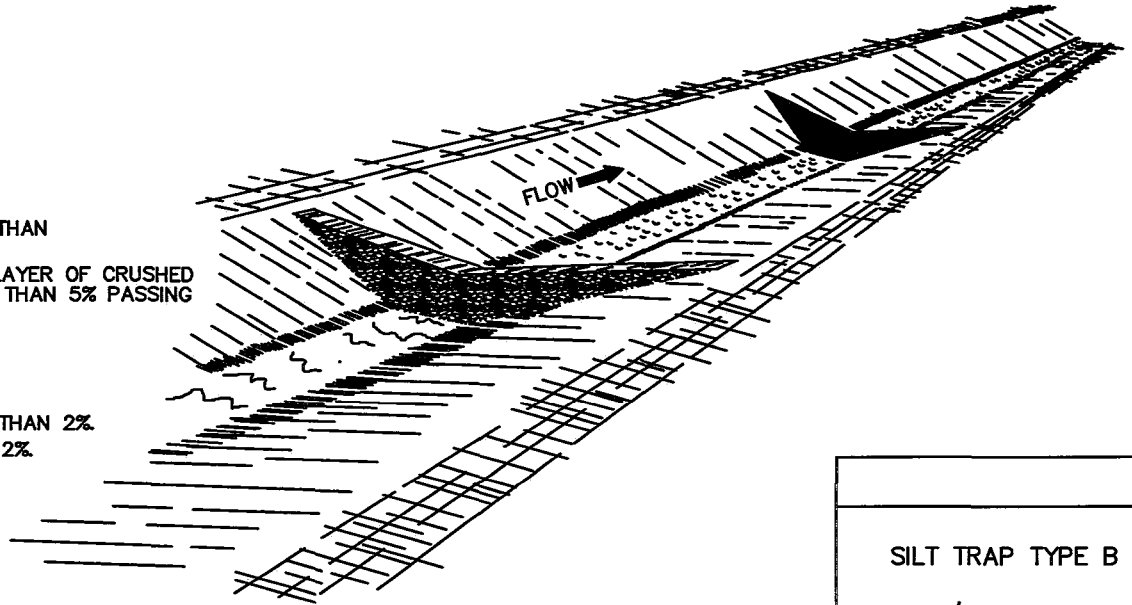

SILT TRAP TYPE B	
SUBMITTED	7-18-13 DATE
016	

USER: JML/LM DATE PLOTTED: January 25, 2018 E-SHEET NAME: MicroStation 08/11/2000

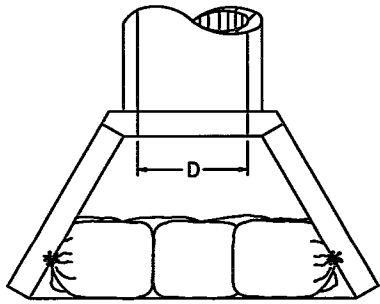

PLAN VIEW

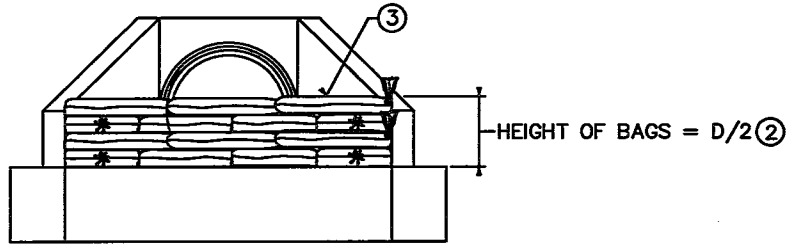

FRONT ELEVATION

~NOTES~

SILT TRAP TYPE C SHALL INCLUDE GEOTEXTILE FABRIC BAGS, NO. 57 STONE, LABOR AND ALL INCIDENTALS NECESSARY FOR ONE COMPLETE INSTALLATION. BID ITEM AND UNIT TO BID:

CODE	PAY ITEM	PAY UNIT
2705	SILT TRAP TYPE C	EACH
2708	CLEAN SILT TRAP TYPE C	EACH

- ① INLET PROTECTION IS SUITABLE FOR USE IN BOTH PAVED AND UNPAVED AREAS.
- ② THE HEIGHT REQUIREMENT IS WAIVED IN CASES WHERE IT WILL CREATE AN UNACCEPTABLE PONDING SITUATION ON THE PAVEMENT OR ON AN ADJACENT PROPERTY.
- ③ INTERWEAVE BAG ENDS TO FILL GAPS BETWEEN BAGS.
4. CONSTRUCT 18" X 30" BAGS OF NON-WOVEN TYPE II GEOTEXTILE FABRIC CONFORMING TO SECTION 843 OF THE STANDARD SPECIFICATIONS. DOUBLE STITCH BAG SEAMS WITH 1 LB. POLYESTER THREAD. ATTACH ONE (1) TIE STRING TO EACH BAG. BAG OPENING SHALL BE ON 18" SIDE.
5. FILL BAGS WITH NO. 57 STONE BETWEEN 1/2 TO 2/3 FULL (50 LB TO 60 LB).
6. SILT TRAP TYPE C SHALL NOT BE USED IN BLUE LINE STREAMS.

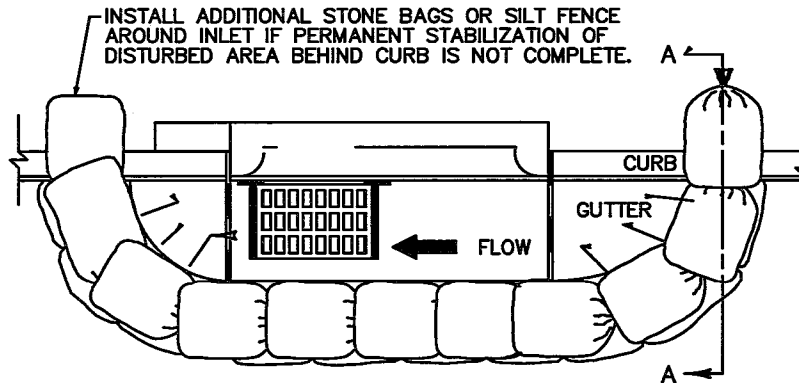

PLAN VIEW

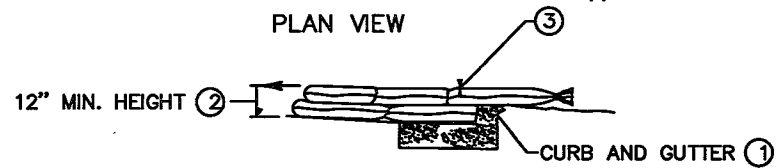

SECTION A~A

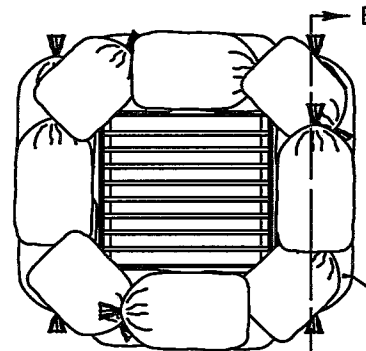

PLAN VIEW

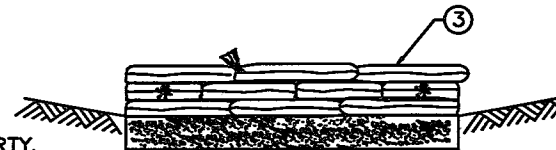

SECTION B~B

KENTUCKY DEPARTMENT OF HIGHWAYS	
SILT TRAP TYPE C	
RDX-230	
SUBMITTED:	DATE: _____
APPROVED:	DATE: _____

(This page left blank intentionally)