

ADDENDUM NO. 1
WATER SYSTEM IMPROVEMENTS
CONTRACT 15-01
16-INCH NORTH WATER TRANSMISSION LINE – PHASE I
OHIO COUNTY WATER DISTRICT
OHIO COUNTY, KENTUCKY
JRWCO JOB NO. 2021

Date of Addendum: Wednesday, July 22, 2015
Bid Opening: To Be Determined

1. Advertisement for Bids, Page AB-2:

Modify the last paragraph on this page to read as follows:

"Any contract(s) awarded under this Invitation for Bids are expected to be funded in part by a loan from the Kentucky Infrastructure Authority and/or by a grant from the U.S. Environmental Protection Agency. Neither the United States nor any of its departments, agencies or employees is or will be a party to this Invitation for Bids or any resulting contract. This procurement will be subject to regulations contained in 40 CFR Part 31.36 or with DOW Procurement Guidance *including* the Davis-Bacon Act."

2. Supplemental General Conditions for Drinking Water State Revolving Fund:

Replace with the attached "Supplemental General Conditions for Drinking Water State Revolving Fund".

J. R. WAUFORD & COMPANY,
CONSULTING ENGINEERS, INC.



J. Gregory Davenport, P.E.
Kentucky License No. 22752

SUPPLEMENTAL GENERAL CONDITIONS
FOR
CLEAN WATER STATE REVOLVING FUND
DRINKING WATER STATE REVOLVING FUND
(Drinking Water and Wastewater)

Project Name: 16-inch North Water Transmission Line – Phase I

Project Number: F15-069

The attached instructions and regulations as listed below shall be incorporated into the Specifications and comprise Special Conditions.

	<u>Attachment No.</u>
SRF Special Provisions	1
KRS Chapter 45A-Kentucky Model Procurement Code	2
Equal Employment Opportunity (EEO) Documents:	
Notice of Requirement for Affirmative Action	3
Contract Specifications (Executive Order 11246)	4
EEO Goals for Region 4 Economic Areas	5
Special Notice #1 - Check List of EEO Documentation	6
Employer Information Report EEO-1 (SF 100)	7
Labor Standards Provisions for Federally Assisted Construction, EPA Form 5720-4	8
Certifications	
Debarment, Suspension and Other Responsibility Matters	9
Anti-lobbying	10
Region 4 Disadvantaged Business Enterprise (DBE)	11
Bonds and Insurance	12
Storm Water General Permit	13
Davis-Bacon Wage Rate Requirements under FY 2013 Continuing Resolution	14
American Iron and Steel Requirement	15

SRF SPECIAL PROVISIONS

- (a) **Line crossings of all roads and streets shall be done in accordance with the Kentucky Transportation Cabinet requirements as may be set forth in the Special Conditions.**
- (b) **Construction is to be carried out so as to prevent by-passing of flows during construction unless a schedule has been approved by the State or EPA, whichever is applicable. Siltation and soil erosion must be minimized during construction. All construction projects with surface disturbance of more than 1 acre during the period of construction must have a KPDES Storm Water General Permit. The permit can be found at the following web address: <https://dep.gateway.ky.gov/eForms/default.aspx?FormID=7>.**

If you have any questions regarding the completion of this form call the Surface Water Permits Branch at (502) 564-3410.

- (c) **Restore disturbed areas to original or better condition.**
- (d) **Use of Chemicals: All chemicals used during project construction or furnished for project operation, whether herbicide, pesticide, disinfectant, polymer, reactant or of other classification, must show approval of either DOW or EPA. Use of all such chemicals and disposal of residues shall be in conformance with instructions on the manufacturer's label.**
- (e) **The construction of the project, including the letting of contracts in connection therewith, shall conform to the applicable requirements of state, territorial, and local laws and ordinances to the extent that such requirements do not conflict with Federal laws and this subchapter.**
- (f) **The owner shall provide and maintain competent and adequate supervision and inspection.**
- (g) **The Kentucky Infrastructure Authority and Kentucky Division of Water shall have access to the site and the project work at all times.**
- (h) **In the event Archaeological materials (arrowheads, stone tools, stone axes, prehistoric and historic pottery, bottles, foundations, Civil War artifacts, and other types of artifacts) are uncovered during the construction of this project, work is to immediately cease at the location and the Kentucky Heritage Council shall be contacted. The telephone number is (502) 564-7005. Construction shall commence at this location until a written release is received from the Kentucky Heritage Council. Failure to report a find could result in legal action.**
- (i) **This procurement will be subject to DOW Procurement Guidance including the Davis-Bacon Act.**
- (j) **Reasonable care shall be taken during construction to avoid damage to vegetation. Ornamental shrubbery and tree branches shall be temporarily tied back, where appropriate, to minimize damage. Trees which receive damage to branches shall be trimmed of those branches to improve the appearance of the tree. Tree trunks receiving damage from equipment shall be treated with a tree dressing.**
- (k) **No wastewater bypassing will occur during construction unless a schedule has been approved by the Kentucky Division of Water.**
- (l) **Change orders to the construction contract (if required) must be negotiated pursuant to DOW/KIA Procurement Guidance for Construction and Equipment Contracts.**

KRS Chapter 45A
Kentucky Model Procurement Code

45A.075 Methods of awarding state contracts.

Except as otherwise authorized by law, all state contracts shall be awarded by:

- (1) Competitive sealed bidding, pursuant to KRS 45A.080; or
- (2) Competitive negotiation, pursuant to KRS 45A.085 and 45A.090 or 45A.180; or
- (3) Noncompetitive negotiation, pursuant to KRS 45A.095; or
- (4) Small purchase procedures, pursuant to KRS 45A.100.

Effective: June 24, 2003

History: Amended 2003 Ky. Acts ch. 98, sec. 4, effective June 24, 2003. -- Created 1978 Ky. Acts ch. 110, sec. 16, effective January 1, 1979.

45A.080 Competitive sealed bidding.

(1) Contracts exceeding the amount provided by KRS 45A.100 shall be awarded by competitive sealed bidding, which may include the use of a reverse auction, unless it is determined in writing that this method is not practicable. Factors to be considered in determining whether competitive sealed bidding is not practicable shall include:

- (a) Whether specifications can be prepared that permit award on the basis of best value; and
- (b) The available sources, the time and place of performance, and other relevant circumstances as are appropriate for the use of competitive sealed bidding.

(2) The invitation for bids shall state that awards shall be made on the basis of best value. In any contract which is awarded under an invitation to bid which requires delivery by a specified date and imposes a penalty for late delivery, if the delivery is late, the contractor shall be given the opportunity to present evidence that the cause of the delay was beyond his control. If it is the opinion of the purchasing officer that there is sufficient justification for delayed delivery, the purchasing officer may adjust or waive any penalty that is provided for in the contract.

(3) Adequate public notice of the invitation for bids and any reverse auction shall be given a sufficient time prior to the date set forth for the opening of bids or beginning of the reverse auction. The notice may include posting on the Internet or publication in a newspaper or newspapers of general circulation in the state as determined by the secretary of the Finance and Administration Cabinet not less than seven (7) days before the date set for the opening of the bids and any reverse auction. The provisions of this subsection shall also apply to price contracts and purchase contracts of state institutions of higher education.

(4) Bids shall be opened publicly or entered through a reverse auction at the time and place designated in the invitation for bids. At the time the bids are opened, or the reverse auction has ended, the purchasing agency shall announce the agency's engineer's estimate, if applicable, and make it a part of the agency records pertaining to the letting of any contract for which bids were received. Each written or reverse auction bid, together with the name of the bidder and the agency's engineer's estimate, shall be recorded and be open to public inspection. Electronic bid opening and posting of the required information for public viewing shall satisfy the requirements of this subsection.

(5) The contract shall be awarded by written notice to the responsive and responsible bidder whose bid offers the best value.

(6) Correction or withdrawal of written or reverse auction bids shall be allowed only to the extent permitted by regulations issued by the secretary.

Effective: July 15, 2010

History: Amended 2010 Ky. Acts ch. 63, sec. 3, effective July 15, 2010. -- Amended 2000 Ky. Acts ch. 509, sec. 1, effective July 14, 2000. -- Amended 1998 Ky. Acts ch. 120, sec. 10, effective July 15, 1998. -- Amended 1997 (1st Extra. Sess.) Ky. Acts ch. 4, sec. 27, effective May 30, 1997. -- Amended 1996 Ky. Acts ch. 60, sec. 2, effective July 15, 1996. -- Amended 1994 Ky. Acts ch. 278, sec. 1, effective July 15, 1994. -- Amended 1982 Ky. Acts ch. 282, sec. 1, effective July 15, 1982. -- Amended 1979 (1st Extra. Sess.) Ky. Acts ch. 9, sec. 1, effective February 10, 1979. -- Created 1978 Ky. Acts ch. 110, sec. 17, effective January 1, 1979.

45A.085 Competitive negotiation.

(1) When, under administrative regulations promulgated by the secretary or under KRS 45A.180, the purchasing officer determines in writing that the use of competitive sealed bidding is not practicable, and except as provided in KRS 45A.095 and 45A.100, a contract may be awarded by competitive negotiation, which may include the use of a reverse auction.

(2) Adequate public notice of the request for proposals and any reverse auction shall be given in the same manner and circumstances as provided in KRS 45A.080(3).

(3) Contracts other than contracts for projects utilizing an alternative project delivery method under KRS 45A.180 may be competitively negotiated when it is determined in writing by the purchasing officer that the bids received by competitive sealed bidding either are unreasonable as to all or part of the requirements, or were not independently reached in open competition, and for which each competitive bidder has been notified of the intention to negotiate and is given reasonable opportunity to negotiate.

(4) Contracts for projects utilizing an alternative project delivery method shall be processed in accordance with KRS 45A.180.

(5) The request for proposals shall indicate the relative importance of price and other evaluation factors, and any reverse auction procedures.

(6) Award shall be made to the responsible and responsive offeror whose proposal is determined in writing to be the most advantageous to the Commonwealth, taking into consideration price and the evaluation factors set forth in the request for proposals and the reciprocal preference for resident bidders required under KRS 45A.494.

(7) Written or oral discussions shall be conducted with all responsible offerors who submit proposals determined in writing to be reasonably susceptible of being selected for award. Discussions shall not disclose any information derived from proposals submitted by competing offerors. Discussions need not be conducted:

(a) With respect to prices, where the prices are fixed by law, reverse auction, or administrative regulation, except that consideration shall be given to competitive terms and conditions;

(b) Where time of delivery or performance will not permit discussions; or

(c) Where it can be clearly demonstrated and documented from the existence of adequate competition or prior experience with the particular supply, service, or construction item, that acceptance of an initial offer without discussion would result in fair and reasonable best value procurement, and the request for proposals notifies all offerors of the possibility that award may be made on the basis of the initial offers.

Effective: July 15, 2010

History: Amended 2010 Ky. Acts ch. 63, sec. 4, effective July 15, 2010; and ch. 162, sec. 8, effective July 15, 2010. -- Amended 2003 Ky. Acts ch. 98, sec. 5, effective June 24, 2003. -- Amended 1997 (1st Extra. Sess.) Ky. Acts ch. 4, sec. 28, effective May 30, 1997. -- Amended 1979 (1st Extra. Sess.) Ky. Acts ch. 9, sec. 2, effective February 10, 1979. -- Created 1978 Ky. Acts ch. 110, sec. 18, effective January 1, 1979.

45A.090 Negotiation after competitive sealed bidding when all bids exceed available funds.

(1) In the event that all bids submitted pursuant to competitive sealed bidding under KRS 45A.080 result in bid prices in excess of the funds available for the purchase, and the chief purchasing officer determines in writing:

DOW – Feb 2016

- (a) That there are no additional funds available from any source so as to permit an award to the responsive and responsible bidder whose bid offers the best value; and
 - (b) The best interest of the state will not permit the delay attendant to a resolicitation under revised specifications, or for revised quantities, under competitive sealed bidding as provided in KRS 45A.080, then a negotiated award may be made as set forth in subsections (2) or (3) of this section.
- (2) Where there is more than one (1) bidder, competitive negotiations pursuant to KRS 45A.085(3) shall be conducted with the three (3) (two (2) if there are only two (2)) bidders determined in writing to be the most responsive and responsible bidders, based on criteria contained in the bid invitation and the reciprocal preference for resident bidders under KRS 45A.494. Such competitive negotiations shall be conducted under the following restrictions:
- (a) If discussions pertaining to the revision of the specifications or quantities are held with any potential offeror, all other potential offerors shall be afforded an opportunity to take part in such discussions; and
 - (b) A request for proposals, based upon revised specifications or quantities, shall be issued as promptly as possible, shall provide for an expeditious response to the revised requirements, and shall be awarded upon the basis of best value.
- (3) Where, after competitive sealed bidding, it is determined in writing that there is only one (1) responsive and responsible bidder, a noncompetitive negotiated award may be made with such bidder in accordance with KRS 45A.095.

Effective: July 15, 2010

History: Amended 2010 Ky. Acts ch. 162, sec. 9, effective July 15, 2010. -- Amended 2003 Ky. Acts ch. 98, sec. 6, effective June 24, 2003. -- Amended 1997 (1st Extra. Sess.) Ky. Acts ch. 4, sec. 29, effective May 30, 1997. -- Created 1978 Ky. Acts ch. 110, sec. 19, effective January 1, 1979.

45A.095 Noncompetitive negotiation.

- (1) A contract may be made by noncompetitive negotiation only for sole source purchases, or when competition is not feasible, as determined by the purchasing officer in writing prior to award, under administrative regulations promulgated by the secretary of the Finance and Administration Cabinet or the governing boards of universities operating under KRS Chapter 164A, or when emergency conditions exist. Sole source is a situation in which there is only one (1) known capable supplier of a commodity or service, occasioned by the unique nature of the requirement, the supplier, or market conditions. Insofar as it is practical, no less than three (3) suppliers shall be solicited to submit written or oral quotations whenever it is determined that competitive sealed bidding is not feasible. Award shall be made to the supplier offering the best value. The names of the suppliers submitting quotations and the date and amount of each quotation shall be placed in the procurement file and maintained as a public record. Competitive bids may not be required:
- (a) For contractual services where no competition exists, such as telephone service, electrical energy, and other public utility services;
 - (b) Where rates are fixed by law or ordinance;
 - (c) For library books;
 - (d) For commercial items that are purchased for resale;
 - (e) For interests in real property;
 - (f) For visiting speakers, professors, expert witnesses, and performing artists;
 - (g) For personal service contracts executed pursuant to KRS 45A.690 to 45A.725; and
 - (h) For agricultural products in accordance with KRS 45A.645.

(2) The chief procurement officer, the head of a using agency, or a person authorized in writing as the designee of either officer may make or authorize others to make emergency procurements when an emergency condition exists.

(3) An emergency condition is a situation which creates a threat or impending threat to public health, welfare, or safety such as may arise by reason of fires, floods, tornadoes, other natural or man-caused disasters, epidemics, riots, enemy attack, sabotage, explosion, power failure, energy shortages, transportation emergencies, equipment failures, state or federal legislative mandates, or similar events. The existence of the emergency condition creates an immediate and serious need for services, construction, or items of tangible personal property that cannot be met through normal procurement methods and the lack of which would seriously threaten the functioning of government, the preservation or protection of property, or the health or safety of any person.

(4) The Finance and Administration Cabinet may negotiate directly for the purchase of contractual services, supplies, materials, or equipment in bona fide emergencies regardless of estimated costs. The existence of the emergency shall be fully explained, in writing, by the head of the agency for which the purchase is to be made. The explanation shall be approved by the secretary of the Finance and Administration Cabinet and shall include the name of the vendor receiving the contract along with any other price quotations and a written determination for selection of the vendor receiving the contract. This information shall be filed with the record of all such purchases and made available to the public. Where practical, standard specifications shall be followed in making emergency purchases. In any event, every effort should be made to effect a competitively established price for purchases made by the state.

Effective: July 15, 2002

History: Amended 2002 Ky. Acts ch. 344, sec. 9, effective July 15, 2002. -- Amended 1997 (1st Extra. Sess.) Ky. Acts ch. 4, sec. 30, effective May 30, 1997. -- Amended 1990 Ky. Acts ch. 496, sec. 4, effective July 13, 1990. -- Created 1978 Ky. Acts ch. 110, sec. 20, effective January 1, 1979

45A.100 Small purchases by state governmental bodies.

(1) Procurements may be made in accordance with small purchase administrative regulations promulgated by the secretary of the Finance and Administration Cabinet, pursuant to KRS Chapter 13A, as follows:

(a) Up to ten thousand dollars (\$10,000) per project for construction and one thousand dollars (\$1,000) for purchases by any state governmental body, except for those state administrative bodies specified in paragraph (b) of this subsection; and

(b) Up to forty thousand dollars (\$40,000) per project for construction or purchases by the Finance and Administration Cabinet, state institutions of higher education, and the legislative branch of government.

(2) Procurement requirements shall not be artificially divided so as to constitute a small purchase under this section. Reverse auctions may be used for small purchase procurements. At least every two (2) years, the secretary shall review the prevailing costs of labor and materials and may make recommendations to the next regular session of the General Assembly for the revision of the then current maximum small purchase amount as justified by intervening changes in the cost of labor and materials.

(3) The secretary of the Finance and Administration Cabinet may grant to any state agency with a justifiable need a delegation of small purchasing authority which exceeds the agency's small purchase limit provided in subsection (1) of this section. Delegations of small purchasing authority shall be granted or revoked by the secretary of the Finance and Administration Cabinet, in accordance with administrative regulations promulgated by the cabinet pursuant to KRS Chapter 13A. These administrative regulations shall establish, at a minimum, the criteria for granting and revoking delegations of small purchasing authority, including the requesting

agency's past compliance with purchasing regulations, the level of training of the agency's purchasing staff, and the extent to which the agency utilizes the Kentucky Automated Purchasing System. The administrative regulations may permit the secretary of the Finance and Administration Cabinet to delegate small purchase procurements up to the maximum amount specified in subsection (1)(b) of this section.

Effective: July 15, 2010

History: Amended 2010 Ky. Acts ch. 63, sec. 5, effective July 15, 2010. -- Amended 2002 Ky. Acts ch. 320, sec. 2, effective July 15, 2002. -- Amended 2000 Ky. Acts ch. 225, sec. 1, effective July 14, 2000. -- Amended 1996 Ky. Acts ch. 60, sec. 1, effective July 15, 1996. -- Amended 1994 Ky. Acts ch. 323, sec. 1, effective July 15, 1994. -- Amended 1990 Ky. Acts ch. 496, sec. 5, effective July 13, 1990. -- Amended 1986 Ky. Acts ch. 384, sec. 1, effective July 15, 1986. -- Amended 1984 Ky. Acts ch. 384, sec. 1, effective July 13, 1984. -- Amended 1982 Ky. Acts ch. 282, sec. 2, effective July 15, 1982. -- Amended 1980 Ky. Acts ch. 242, sec. 1, effective July 15, 1980; and ch. 250, sec. 19, effective April 9, 1980. -- Created 1978 Ky. Acts ch. 110, sec. 21, effective January 1, 1979.

**NOTICE OF REQUIREMENT FOR AFFIRMATIVE ACTION TO ENSURE
EQUAL EMPLOYMENT OPPORTUNITY (EXECUTIVE ORDER 11246)**

The following excerpts are from 45 FR 65984 (October 3, 1980):

The minority and female goals apply to Federal and federally assisted construction contractors and subcontractors which have covered contracts. The goals are expressed as a percentage of the total hours worked by such a covered or subcontractor's entire onsite construction workforce, which is working on any construction site within a relevant area. The goal applies to each construction craft and trade in the contractor's entire workforce in the relevant area including those employees working on private non-federally involved projects.

Until further notice, the following goals for minority utilization in each construction craft and trade shall be included in all Federal or federally assisted construction contracts and subcontracts in excess of \$10,000 to be performed in the respective geographic area. The goals are applicable to each nonexempt contractor's total onsite construction workforce, regardless of whether or not part of that workforce is performing work on a Federal, federally assisted or non-federally related project, contract or subcontract.

Construction contractors which are participating in an approved Hometown Plan (see 41 CFR 60-4.5) are required to comply with the goals of the Hometown Plan with regard to construction work they perform in the area covered by the Hometown Plan. With regard to all their other covered construction work, such contractors are required to comply as follows:

Goals for female participation in each trade.....6.9%
Goals for minority participation in each trade.....Insert goals for each year
(see Attachment Number 5)

These goals are applicable to all the Contractor's construction work (whether or not it is Federal or Federally assisted) performed in the covered area.

The following excerpts are from 45 FR 65977 (October 3, 1980):

The Contractor's compliance with the Executive Order and the regulations in 41 CFR Part 60-4 shall be based on its implementation of the Equal Opportunity Clause, specific affirmative action obligations required by the specifications set forth in 41 CFR 60-4.3(a), and its efforts to meet the goals established for the geographical area where the contract resulting from this solicitation is to be performed. The hours of minority and female employment and training must be substantially uniform throughout the length of the contract, and in each trade, and the contractor shall make a good faith effort to employ minorities and women evenly on each of its projects. The transfer of minority or female employees or trainees from Contractor to Contractor or from project to project for the sole purpose of meeting the Contractor's goals shall be a violation of the contract, the Executive Order and the regulations in 41 CFR Part 60-4. Compliance with the goals will be measured against the total work hours performed.

3. The Contractor shall provide written notification to the Director of the Office of Federal Contract Compliance Programs within 10 working days of award of any construction subcontract in excess of \$10,000 at any tier for construction work under the contract resulting from this solicitation. The notification shall list the name, address and telephone number of the subcontractor; employer identification number; estimated dollar amount of the subcontract; estimated starting and completion dates of the subcontract; and the geographical area in which the contract is to be performed.

4. As used in this Notice, and in the contract resulting from this solicitation, the covered area is (insert description of the geographical areas where the contract is to be performed giving the state, country, and city, if any).

DOW— Feb 2016

**STANDARD FEDERAL EQUAL EMPLOYMENT OPPORTUNITY CONSTRUCTION
CONTRACT SPECIFICATIONS (EXECUTIVE ORDER 11246)**

EEO Specifications

Following is the standard language, which must be incorporated into all solicitations for offers and bids on all Federal and Federally assisted construction contracts or subcontracts in excess of \$10,000 to be performed in designated geographical areas:

1. As used in these specifications:
 - (a) Covered Area means the geographical area described in the solicitation from which this contract resulted.
 - (b) Director means Director, Office of Federal Contract Compliance Program, United States Department of Labor, or any person to whom the Director delegates authority;
 - (c) Employer identification number means the Federal Social Security number used on the Employer's Quarterly Federal Tax Return, U.S. Treasury Department Form 941.
 - (d) Minority includes:
 - (i) Black (all persons having origins in any of the Black African racial groups not of Hispanic origin);
 - (ii) Hispanic (all persons of Mexican, Puerto Rican, Cuban, Central or South American or other Spanish Culture or origin, regardless of race);
 - (iii) Asian and Pacific Islander (all persons having origins in any of the original peoples of the Far East, Southeast Asia, the Indian Subcontinent, or the Pacific Islands); and
 - (iv) American Indian or Alaskan Native (all persons having origins in any of the original peoples of North America and maintaining identifiable tribal affiliations through membership and participation or community identification).
2. Whenever the Contractor or any Subcontractor at any tier, subcontracts a portion of the work involving any construction trade, it shall physically include in each subcontract in excess of \$10,000 the provisions of these specifications and the Notice which contains the applicable goals for minority and female participation and which is set forth in the solicitations from which this contract resulted.
3. If the Contractor is participating (pursuant to 41 CFR 60-4.5) in a Hometown Plan approved by the U.S. Department of Labor in the covered area either individually or through an association, its affirmative action obligations on all work in the Plan area (including goals and timetables) shall be in accordance with that Plan for those trades which have unions participating in the Plan. Contractors must be able to demonstrate their participation in and compliance with the provisions of any such Hometown Plan. Each Contractor or Subcontractor participating in an approved Plan is individually required to comply with its obligations under the EEO clause, and to make a good faith effort to achieve each goal under the Plan in each trade in which it has employees. The overall good faith performance by other Contractors or Subcontractors toward a goal in an approved Plan does not excuse any covered Contractor's or Subcontractor's failure to take a good faith efforts to achieve the Plan goals and timetables.
4. The Contractor shall implement the specific affirmative action standards provided in paragraphs 7-a through p of these specifications. The goals set forth in the solicitation from which this contract resulted are expressed as percentages of the total hours of employment and training of minority and female utilization the Contractor should reasonably be able to achieve in each construction trade in which it has

employees in the covered area. The Contractor is expected to make substantially uniform progress toward its goals in each craft during the period specified.

5. Neither the provisions of any collective bargaining agreement, nor the failure by a union with whom the Contractor has a collective bargaining agreement, to refer either minorities or women shall excuse the Contractor's obligations under these specifications, Executive Order 11246, or the regulations promulgated pursuant thereto.
6. In order for the non-working training hours of apprentices and trainees to be counted in meeting the goals, such apprentices and trainees must be employed by the contractor during the training period, and the Contractor must have made a commitment to employ the apprentices and trainees at the completion of their training, subject to the availability of employment opportunities. Trainees must be trained pursuant to training programs approved by the U.S. Department of Labor.
7. The Contractor shall take specific affirmative action to ensure equal employment opportunity. The evaluation of the Contractor's compliance with these specifications shall be based upon its effort to achieve maximum results from its actions. The Contractor shall document these efforts fully, and shall implement affirmative actions steps at least as extensively as the following:
 - a. Ensure and maintain a working environment free of harassment, intimidation, and coercion at all sites, and in all facilities at which the contractor's employees are assigned to work. The Contractor, where possible, will assign two or more women to each construction project. The Contractor shall specifically ensure that all foremen, superintendents, and other on-site supervisory personnel are aware of and carry out the Contractor's obligation to maintain such a working environment, with specific attention to minority or female individuals working at such sites or in such facilities.
 - b. Establish and maintain a current list of minority and female recruitment sources, provide written notification to minority and female recruitment sources and to community organizations when the contractor or its unions have employment opportunities available, and maintain a record of the organizations responses.
 - c. Maintain a current file of the names, addresses and telephone numbers of each minority and female off-the-street applicant and minority or female referral from a union, a recruitment source or community organization and of what action was taken with respect to each such individual. If such individual was sent to the union hiring hall for referral and was not referred back to the Contractor by the union or, if referred, not employed by the contractor, this shall be documented in the file with the reason therefore, along with whatever additional actions the contractor may have taken.
 - d. Provide immediate written notification to the Director when the union or unions with which the Contractor has a collective bargaining agreement has not referred to the Contractor a minority person or woman sent by the Contractor, or when the Contractor has other information that the union referral process has impeded the Contractor's efforts to meet its obligation.
 - e. Develop on-the-job training opportunities and/or participate in training programs for the area which expressly include minorities and women, including upgrading programs and apprenticeship and trainee programs relevant to the Contractor's employment needs, especially those programs funded or approved by the Department of Labor. The Contractor shall provide notice of these programs to the sources complied under 7-b above.
 - f. Disseminate the Contractor's EEO policy by providing notice of the policy to unions and training programs and requesting their cooperation in assisting the Contractor in meeting its EEO obligations; by including it in any policy manual and collective bargaining agreement; by publicizing it in the company newspaper, annual report, etc.; by specific review of the policy with all management personnel and with all minority and female employees at least once a year; and

by posting the company EEO policy on bulletin boards accessible to all employees at each location where construction work is performed.

g. Review, at least annually, the company's EEO policy and affirmative action obligations under these specifications with all employees having any responsibility for hiring, assignment, lay-off, termination or other employment decisions including specific review of these items with on-site supervisory personnel such as Superintendents, General Foreman, etc., prior to the initiation of construction work at any job site. A written record shall be made and maintained identifying the time and place of these meetings, persons attending, subject matter discussed, and disposition of the subject matter.

h. Disseminate the Contractor's EEO policy externally by including it in any advertising in the news media, specifically including minority and female news media, and providing written notification to and discussing the Contractor's EEO policy with other Contractors and Subcontractors with whom the Contractor does or anticipates doing business.

i. Direct its recruitment efforts, both oral and written, to minority, female and community organizations, to schools with minority and female students and to minority and female recruitment and training organizations serving the Contractor's recruitment area and employment needs. Not later than one month prior to the date for the acceptance of applications for apprenticeship or other training by any recruitment source, the contractor shall send written notification to organizations such as the above, describing the openings, screening procedures, and tests to be used in the selection process.

j. Encourage present minority and female employees to recruit other minority persons and women and, where reasonable, provide after school, summer and vacation employment to minority and female youth both on the site and in other areas of a Contractor's workforce.

k. Validate all tests and other selection requirements where there is an obligation to do so under 41 CFR Part 60-3.

l. Conduct, at least annually, an inventory and evaluation of all minority and female personnel for promotional opportunities and encourage these employees to seek or to prepare for, through appropriate training, etc., such opportunities.

m. Ensure that seniority practices, job classifications, work assignments and other personnel practices, do not have a discriminatory effect by continually monitoring all personnel and employment related activities to ensure that EEO policy and the Contractor's obligations under these specifications are being carried out.

n. Ensure that all facilities and company activities are nonsegregated except that separate or single-user toilet and necessary changing facilities shall be provided to assure privacy between the sexes.

o. Document and maintain a record of all solicitations of offers for subcontracts from minority and female construction contractors and suppliers, including circulation of solicitations to minority and female contractor associations and other business associations.

p. Conduct a review, at least annually, of all supervisor's adherence to and performance under the Contractor's EEO policies and affirmative action obligations.

8. Contractors are encouraged to participate in voluntary associations, which assist in fulfilling one or more of their affirmative actions obligations (7 a through p). The efforts of a contractor association, joint contractor-union, contractor-community, of other similar group of which the contractor is a member and participant may be asserted as fulfilling any one or more of its obligations under 7 a through p of these specifications provided that the contractor actively participates in the group, makes every effort to assure

that the group has a positive impact on the employment of minorities and women in the industry, ensures that the concrete benefits of the program are reflected in the Contractor's minority and female workforce participation, makes a good faith effort to meet its individual goals and timetables, and can provide access to documentation which demonstrates the effectiveness of actions taken on behalf of the Contractor. The obligation to comply, however, is the Contractor's and failure of such a group to fulfill an obligation shall not be defense for the Contractor's noncompliance.

9. A single goal for minorities and a separate single goal for women have been established. The contractor, however, is required to provide equal employment opportunity and to take affirmative action for all minority groups, both male and female, and all women, both minority and non-minority. Consequently, the Contractor may be in violation of the Executive Order if a particular group is employed in a substantially disparate manner (for example: even though the Contractor has achieved its goal for women generally, the Contractor may be in violation of the Executive Order if a specific minority group of women is underutilized).

10. The Contractor shall not use the goals and timetables for affirmative action standards to discriminate against any person because of race, color, religion, sex or national origin.

11. The Contractor shall not enter into any Subcontract with any person or firm debarred from Government contracts pursuant to Executive Order 11246.

12. The Contractor shall carry out such sanctions and penalties for violation of these specifications and of the Equal Opportunity Clause, including suspension, termination and cancellation of existing subcontracts as may be imposed or ordered pursuant to Executive Order 11246, as amended, and its implementing regulations, by the Office of Federal Contract Compliance Programs. Any Contractor who fails to carry out such sanctions and penalties shall be in violation of these specifications and executive Order 11246, as amended.

13. The Contractor, in fulfilling its obligations under these specifications, shall implement specific affirmative action steps, at least as extensive as those standards prescribed in paragraph 7 of these specifications, so as to achieve maximum results from its efforts to ensure equal employment opportunity. If the Contractor fails to comply with the requirements of the Executive Order, the implementing regulations, or these specifications, the Director shall proceed in accordance with 41 CFR 60-4.8.

14. The Contractor shall designate a responsible official to monitor all employment related activity to ensure that the company EEO policy is being carried out, to submit reports relating to the provisions hereof as may be required by the Government and to keep records. Records shall at least include for each employee the name, address, telephone numbers, construction trade, union affiliation, if any, employee identification number when assigned, social security number, race, sex, status (e.g., mechanic, apprentice, trainee, helper or laborer), dates of changes in status, hours worked per week in the indicated trade, rate of pay, and locations at which the work was performed. Records shall be maintained in an easily understandable and retrievable form; however, to the degree that existing records satisfy this requirement, contractors shall not be required to maintain separate records.

15. Nothing herein provided shall be construed as a limitation upon the application of other laws which establish different standards of compliance or upon the application of requirements for the hiring of local or other area residents (e.g., those under the Public Works Employment Act of 1977 and the Community Development Block Grant Program).

EEO Goals for Economic Areas in Region 4

Source: Appendix B-80 in 45 FR 65984 (October 3, 1980)

Kentucky:

053 Knoxville, TN
 SMSA Counties:
 3840 Knoxville, TN6.6
 TN Anderson; TN Blount; TN Knox; TN Union.
 Non-SMSA Counties4.5
 KY Bell; KY Harlan; KY Knox; KY Laurel; KY McCreary; KY Wayne; KY Whitley; TN
 Campbell; TN Claiborne; TN Cocke; TN Cumberland; TN Fentress; TN Grainger, TN Hamblen;
 TN Jefferson; TN Loudon; TN Morgan; TN Roane; TN Scott;
 TN Sevier.

054 Nashville, TN:
 SMSA Counties:
 1660 Clarksville - Hopkinsville, TN - KY18.2
 KY Christian; TN Montgomery.
 5360 Nashville - Davidson, TN15.8
 TN Cheatham, TN Davidson; TN Dickson; TN Robertson; TN Rutherford; TN Sumner; TN
 Williamson; TN Wilson.
 Non-SMSA Counties12.0
 KY Allen; KY Barren; KY Butler; KY Clinton; KY Cumberland; KY Edmonson; KY Logan; KY
 Metcalfe; KY Monroe; KY Simpson; KY Todd; KY Trigg; KY Warren; TN Bedford; TN Cannon;
 TN Clay; TN Coffee; TN DeKalb; TN Franklin; TN Giles; TN Hickman; TN Houston; TN
 Humphreys; TN Jackson; TN Lawrence; TN Lewis; TN Macon; TN Marshall; TN Maury; TN
 Moore; TN Overton; TN Perry; TN Pickett; TN Putnam; TN Smith; TN Stewart; TN Trousdale;
 TN Van Buren; TN Warren; TN Wayne; TN White.

056 Paducah, KY:
 Non-SMSA Counties5.2
 IL Hardin; IL Massac; IL Pope; KY Ballard; KY Caldwell; KY Calloway. KY Carlisle; KY
 Crittenden; KY Fulton; KY Graves; KY Hickman; KY Livingston; KY Lyon. KY McCracken; KY
 Marshall.

057 Louisville, KY:
 SMSA Counties:
 4520 Louisville, KY-IN11.2
 IN Clark; IN Floyd; KY Bullitt; KY Jefferson; KY Oldham.
 Non-SMSA Counties9.6
 IN Crawford; IN Harrison; IN Jefferson; IN Orange; IN Scott; IN Washington; KY Breckinridge;
 KY Grayson; KY Hardin; KY Hart; KY Henry; KY Larue; KY Marion;
 KY Meade; KY Nelson; KY Shelby; KY Spencer; KY Trimble; KY Washington.

058 Lexington, KY
 SMSA Counties
 4280 Lexington-Fayette, KY10.8
 KY Bourbon; KY Clark; KY Fayette; KY Jessamine; KY Scott; KY Woodford.
 Non-SMSA Counties7.0
 KY Adair KY Anderson; KY Bath; KY Boyle; KY Breathitt; KY Casey; KY Clay; KY Estill; KY
 Franklin; KY Garrard; KY Green; KY Harrison; KY Jackson; KY Knott; KY Lee; KY Leslie; KY
 Letcher; KY Lincoln; KY Madison; KY Magoffin; KY Menifee; KY Mercer; KY Montgomery;
 KY Morgan. KY Nicholas; KY Owsley; KY Perry; KY Powell; KY Pulaski; KY Rockcastle; KY
 Russell; KY Taylor; KY Wolfe.

059 Huntington, WV:
 SMSA Counties:
 3400 Huntington – Ashland, WV-KY-OH2.9
 KY Boyd; KY Greenup; OH Lawrence; WV Cabell; WV Wayne.
 Non-SMSA Counties2.5
 KY Carter; KY Elliott; KY Floyd; KY Johnson; KY Lawrence; KY Martin; KY Pike; KY Rowan;
 OH Gallia; WV Lincoln; WV Logan; WV Mason; WV Mingo.

067 Cincinnati, OH:
 SMSA Counties:
 1640 Cincinnati, OH-KY-IN11.0
 IN Dearborn; KY Boone; KY Campbell; KY Kenton; OH Clermont;
 OH Hamilton; OH Warren.

3200 Hamilton-Middletown, OH	5.0
OH Butler.	
Non-SMSA Counties	9.2
IN Franklin; IN Ohio; IN Ripley; IN Switzerland; KY Bracken; KY Carroll; KY Fleming; KY Gallatin; KY Grant; KY Lewis; KY Mason; KY Owen; KY Pendleton; KY Robertson; OH Adams; OH Brown; OH Clinton; OH Highland.	
080 Evansville, IN:	
SMSA Counties	
2440 Evansville, IN-KY	4.8
IN Gibson; IN Posey; IN Vanderburgh; IN Warrick; KY Henderson.	
5990 Owensboro, KY	4.7
KY Daviess.	
Non-SMSA Counties	3.5
IL Edwards; IL Gallatin; IL Hamilton; IL Lawrence; IL Saline; IL Wabash; IL White; IN Dubois; IN Knox; IN Perry; IN Pike; IN Spencer; KY Hancock; KY Hopkins; KY McLean; KY Muhlenberg; KY Ohio; KY Union; KY Webster.	

**CHECK LIST OF EEO DOCUMENTATION FOR BIDDERS
ON GRANT/LOAN CONSTRUCTION
(Required by Executive Order 11246 as amended)**

The low, responsive responsible bidder must forward the following items, in duplicate, to the owner no later than ten (10) days after bid opening. The owner shall have one (1) copy available for inspection by the Office of Federal Contracts Compliance within 14 days after the bid opening. The web site for the OFCC is http://www.dol.gov/ofccp/regs/compliance/ca_11246.htm.

1. Project Number. Project Location. Type of Construction.
2. Proof of registration with the Joint Reporting Commission. (See Attachment Number 7.)
3. Copy of Affirmative Action Plan of contractor. Indicate company official responsible for EEO.
4. List of current construction contracts, with dollar amount. List contracting Federal Agency, if applicable.
5. Statistics concerning company percent workforce, permanent and temporary, by sex, race, trade, handicapped, and age. 40 CFR Part 7.
6. List of employment sources for project in question. If union sources are utilized, indicate percentage of minority membership within the union crafts.
7. Anticipated employment needs for this project, by sex, race and trade, with estimate of minority participation in specific trades.
8. List of subcontractors (name, address and telephone) with dollar amount and duration of subcontract. Subcontractor contracts over \$10,000 must submit items 1- 8. The following information must be provided for all supplier contracts regardless of contract size: name of company, contact person, address, telephone number, dollar value of the contract, and a list of the materials to be supplied to the prime contractor.
9. List of any subcontract work yet to be committed with estimate of dollar amount and duration of contract.
10. Contract Price. Duration of prime contract.
11. DBE Documents - See special instructions regarding use of Minority, and Women Owned, and Small Businesses.

Employer Information Report EEO-1

Under the direction of the US Equal Employment Opportunity Commission, the Joint Reporting Committee is responsible for the full-length, multi-phase processing of employment statistics collected on the Employer Information Report EEO-1. This report, also termed Standard Form 100, details the sex and race/ethnic composition of an employer's work force by job category.

The Employer Information EEO-1 survey is conducted annually under the authority of Public Law 88-352, Title VII of the Civil Rights Act of 1964, as amended by the Equal Employment Opportunity Act of 1972. All employers with 15 or more employees are covered by Public Law 88-352 and are required to keep employment records as specified by Commission regulations. Based on the number of employees and federal contract activities, certain large employers are required to file an EEO-1 Report on an annual basis.

The EEO-1 Report must be filed by:

(A) All private employers who are: (1) subject to Title VII of the Civil Rights Act of 1964 (as amended by the Equal Employment Opportunity Act of 1972) with 100 or more employees EXCLUDING State and local governments, primary and secondary school systems, institutions of higher education, Indian tribes and tax-exempt private memberships clubs other than labor organizations; OR (2) subject to Title VII who have fewer than 100 employees if the company is owned or affiliated with another company, or there is centralized ownership, control or management (such as central control of personnel policies and labor relations) so that the group legally constitutes a single enterprise and the entire enterprise employs a total of 100 or more employees.

(B) All federal contractors (private employers), who: (1) are not exempt as provided for by 41 CFR 60-1.5, (2) have 50 or more employees, and (a) are prime contractors or first-tier subcontractors, and have a contract, subcontract, or purchase order amounting to \$50,000 or more; or (b) serve as depository of Government funds in any amount, or (c) is a financial institution which is an issuing or paying agent for U.S. Savings Bonds and Notes.

Only those establishments located in the District of Columbia and the 50 states are required to submit the EEO-1 Report. No Reports should be filed for establishments in Puerto Rico, the Virgin Islands or other American Protectorates.

When filing for the EEO-1 Report for the first time, go to the web site at:

<http://www.eeoc.gov/employers/eeo1survey/>

and select "Filing Time Filers" from the box labeled INFORMATION. File out the electronic questionnaire to enter your company into Joint Reporting Committee (JRC) system. Once you have completed the registration process, you will be contacted on how to proceed with the EEO-1 Report. If you have previously registered with the JRC, follow their instructions to update your information.

Labor Standards Provisions for Federally Assisted Construction

Labor standards provisions applicable to contracts covering federally financed and assisted construction (29 CFR 5.5, Contract Provisions and Related Matters) that apply to EPA Special Appropriations Projects grants are:

(a)(4)(iii) Equal employment opportunity. The utilization of apprentices, trainees and journeymen under this part shall be in conformity with the equal employment opportunity requirements of Executive Order 11246, as amended, and 29 CFR Part 30.

(a)(5) Compliance with Copeland Act requirements. The contractor shall comply with the requirements of 29 CFR Part 3, which are incorporated by reference in this contract.

(a)(6) Subcontracts. The contractor or subcontractor shall insert in any subcontracts the clauses contained in 29 CFR 5.5 (a) (1) through (10) and such other clauses as the U.S. Environmental Protection Agency may by appropriate instructions require, and also a clause requiring the subcontractors to include these clauses in any lower tier subcontracts. The prime contractor shall be responsible for the compliance by any subcontractor or lower tier subcontractor with all the contract clauses in 29 CFR 5.5.

(a)(7) Contract termination: debarment. A breach of the contract clauses in 29 CFR 5.5 may be grounds for termination of the contract, and debarment as a contractor and a subcontractor as provided in 29 CFR 5.12.

(b) Contractor Work Hours and Safety Standards Act. The Administrator, EPA shall cause or require the contracting officer to insert the following clauses set forth in paragraph (b)(1),(2),(3), and (4) of this section in full in any contract subject to the overtime provisions of the Contract Work Hours and Safety Standards Act. These clauses shall be inserted in addition to the clauses required by *Section 5.5(a) of this title. As used in this paragraph, the terms laborers and mechanics include watchmen and guards.

(1) Overtime requirements. No contractor or subcontractor contracting for any part of the contract work which may require or involve the employment of laborers or mechanics shall require or permit any such laborer or mechanic in any work week in which he or she is employed on such work to in excess of forty hours in such workweek unless such laborer or mechanic receives compensation at a rate not less than one and one-half times the basic rate of pay for all hours worked in excess of forty hours in such workweek.

(2) Violation; liability for unpaid wages; liquidated damages. In the event of any violation of the clause set forth in paragraph (b) (1) of this section the contractor and any subcontractor responsible therefore shall be liable for the unpaid wages. In addition, such contractor and subcontractor shall be liable to the United States (in the case of work done under contract for the District of Columbia or a territory, to such District or to such territory), for unliquidated damages. Such liquidated damages shall be computed with respect to each individual laborer or mechanic, including watchmen and guards, employed in violation of the clause set forth in paragraph (b)(1) of this section, in the sum of \$10 for each calendar day on which such individual was required or permitted to work in excess of the standard workweek of forty hours without payment of the overtime wages required by the clause set forth in paragraph (b)(1) of this section.

(3) Withholding for unpaid wages and liquidated damages. The U.S. Environmental Protection Agency shall upon its own action or upon written request of an authorized representative of the Department of Labor withhold or cause to be withheld, from any moneys payable on account of work performed by the contractor or subcontractor under any such contract or any other Federal contract with the same prime contractor, or any other Federally- assisted contract subject to the Contract Work Hours and Safety Standards Act, which is held by the same prime contractor, such liabilities of such contractor or

subcontractor for unpaid wages and liquidated damages as provided in the clause set forth in paragraph (b) (2) of this section.

(4) Subcontracts. The contractor or subcontractor shall insert in any subcontracts the clauses set forth in paragraph (b)(1) through (4) of this section and also a clause requiring the subcontractors to include these clauses in any lower tier subcontracts. The prime contractor shall be responsible for compliance by any subcontractor or lower tier subcontractor with the clauses set forth in paragraphs (b)(1) through (4) of this section.

(c) In addition to the clauses contained in paragraph (b), in any contract subject only to the Contract Work Hours and Safety Standards Act and not to any of the other statutes cited in section 5.1, the Administrator of EPA shall cause or require the contracting officer to insert a clause requiring that the contractor or subcontractor shall maintain payrolls and basic payroll records during the course of the work and shall preserve them for a period of three years from the completion of the contract for all laborers and mechanics, including guards and watchmen, working on the contract. Such records shall contain the name and address of each such employee, social security number, correct classifications, hourly worked, deductions made, and actual wages paid. Further, the Administrator of EPA shall cause or require the contracting officer to insert in any such contract a clause providing that the records to be maintained under this paragraph shall be made available by the contractor or subcontractor for inspection, copying, or transcription by authorized representatives of the U.S. Environmental Protection Agency and the Department of Labor, and the contractor or subcontractor will permit such representatives to interview employees during working hours on the job. (Approved by the Office of Management and Budget under OMB control numbers 1215-0140 and 1215-0017.)

CERTIFICATIONS

Debarred Firms

All prime Construction Contractors shall certify that Subcontractors have not and will not be awarded to any firm that is currently on the EPA Master List of Debarred, Suspended and Voluntarily Excluded Persons in accordance with the provisions of 40 CFR 32.500(c). Debarment action is taken against a firm for noncompliance with Federal Law.

All bidders shall complete the attached certification (Attachment Number 9) and submit to the owner with the bid proposal.

Anti-lobbying Certification

All prime Construction Contractors must certify (Attachment Number 10) that no appropriated funds were or will be expended for the purpose of lobbying the Executive or Legislative Branches of the Federal Government or Federal Agency concerning this contract (contract in excess of \$100,000). If the Contractor has made or agreed to make payment to influence any member of Congress in regard to award of this contract, a Disclosure Form must be completed and submitted to the owner with the bid proposal.

All prime Contractors must require all Subcontractors to submit the certification, which must also be submitted to the owner.

**CERTIFICATION REGARDING DEBARMENT,
SUSPENSION AND OTHER RESPONSIBILITY MATTERS**

The prospective participant certifies to the best of its knowledge and belief that it and its principals:

- (a) Are not presently debarred, suspended, proposed for debarment, declared ineligible, or voluntarily excluded from covered transactions by any Federal department or agency;
- (b) Have not within a three year period preceding this proposal been convicted of or had a civil judgment rendered against them for commission of fraud or a criminal offense in connection with obtaining, attempting to obtain, or performing a public (Federal, State, or local) transaction or contract under a public transaction; violation of Federal or State antitrust statutes or commission of embezzlement, theft, forgery, bribery, falsification or destruction of records, making false statements, or receiving stolen property;
- (c) Are not presently indicted for or otherwise criminally or civilly charged by a government entity (Federal, State, or Local) with commission of any of the offenses enumerated in paragraph (1)(b) of this certification; and
- (d) Have not within a three-year period preceding this application/proposal had one or more public transactions (Federal, State, or local) terminated for cause or default.

I understand that a false statement on this certification may be grounds for rejection of this proposal or termination of the award. In addition, under 18 USC Sec. 1001, a false statement may result in a fine of up to \$10,000 or imprisonment for up to 5 years, or both.

Typed Name & Title of Authorized Representative

Signature of Authorized Representative

Date

_____ I am unable to certify to the above statements. My explanation is attached.

CERTIFICATION REGARDING LOBBYING
Certification for Contracts, Grants,
Loans, and Cooperative Agreements

The undersigned certifies, to the best of his or her knowledge and belief, that:

(1) No Federal appropriated funds have been paid or will be paid, by or on behalf of the undersigned, to any person for influencing or attempting to influence an officer or employee of an agency, a Member of Congress, an officer or employee of Congress, or an employee of a Member of Congress in connection with the awarding of any Federal contract, the making of any Federal grant, the making of any Federal loan, the entering into of any cooperative agreement, and the extension, continuation, renewal, amendment, or modification of any Federal contract, grant, loan, or cooperative agreement.

(2) If any funds other than Federal appropriated funds have been paid or will be paid to any person for influencing or attempting to influence an officer or employee of any agency, a Member of Congress, an officer or employee of Congress, or an employee of a Member of Congress in connection with this Federal contract, grant, loan, or cooperative agreement, the undersigned shall complete and submit Standard Form-LLL, "Disclosure Form to Report Lobbying," in accordance with its instructions.

(3) The undersigned shall require that the language of this certification be included in the award documents for all sub-awards at all tiers (including subcontracts, sub-grants, and contracts under grants, loans, and cooperative agreements) and that all sub-recipients shall certify and disclose accordingly.

This certification is a material representation of fact upon which reliance was placed when this transaction was made or entered into. Submission of this certification is a prerequisite for making or entering into this transaction imposed by section 1352, title 31, U.S. Code. Any person who fails to file the required certification shall be subject to a civil penalty of not less than \$10,000 and not more than \$100,000 for each such failure.

Typed Name & Title of Authorized Representative

Signature of Authorized Representative

Date

_____ I am unable to certify to the above statements. My explanation is attached.

EPA DISADVANTAGED BUSINESS ENTERPRISE PROGRAM

EPA's Disadvantaged Business Enterprise Program rule applies to contract procurement actions funded in part by EPA assistance agreements awarded after May 27, 2008. The rule is found at Federal regulation Title 40, Part 33. Specific responsibilities are highlighted below.

Grant recipient responsibilities:

- Conduct an Availability Analysis and negotiate fair share objectives with EPA (§33.411), or adopt the fair share objectives of the oversight state agency revolving loan fund for comparable infrastructure. (§33.405(b)(3)).
- Include the Appendix A term and condition in each contract with a primary contractor (§3.106). The term and condition is included in the EPA Region 4 contract specifications insert *FEDERAL REQUIREMENTS AND CONTRACT PROVISIONS FOR SPECIAL APPROPRIATION ACT PROJECTS US ENVIRONMENTAL PROTECTION AGENCY, Region III, June 2008*.
- Employ the six Good Faith Efforts during prime contractor procurement (§33.301).
- Require prime contractor to comply with the following prime contractor requirements of Title 40 Part 33:
 - To employ the six Good Faith Efforts steps in paragraphs (a) through (e) of §33.301 if the prime contractor awards subcontracts (§33.301(f)).
 - To provide EPA form 6100-2 – *DBE Subcontractor Participation Form* to all DBE subcontractors (§33.302(e)).
 - To submit EPA forms 6100-3 – *DBE Program Subcontractor Performance Form* and 6100-4 – *DBE Program Subcontractor Utilization Form* with bid package or proposal. (§33.302 (f) and (g)).
 - To pay its subcontractor for satisfactory performance no more than 30 days from the prime contractor's receipt of payment from the recipient (§33.302(a)).
 - To notify recipient in writing by its prime contractor prior to any termination of a DBE subcontractor for convenience by the prime contractor (§33.302(b)).
 - To employ the six good faith efforts described in §33.301 if soliciting a replacement subcontractor after a DBE subcontractor fails to complete work under the subcontract for any reason. (§33.302(c)).
 - To employ the six good faith efforts described in §33.301 even if the prime contractor has achieved its fair share objectives under subpart D of Part 33. (§33.302(d)).

- Semiannually complete and submit to Charles Hayes, EPA Region 4 DBE Coordinator EPA form 5700-52A summarizing DBE participation achieved during the previous six months (§33.502).
- Maintain records documenting its compliance with the requirements of Title 40 Part 33, including documentation of its, and its prime contractors', good faith efforts (§33.501(a)).

Prime Contractor Responsibilities:

- Employ the six Good Faith Efforts steps in paragraphs (a) through (e) of §33.301 if the prime contractor awards subcontracts (§33.301(f)).
- Provide EPA form number 6100-2 – *DBE Program Subcontractor Participation Form* and form number 6100-3 – *DBE Program Subcontractor Performance Form* to each DBE subcontractor prior to opening of the contractor's bid or proposal (§33.302(e) and (f)).
- Complete EPA form number 6100-4 – *DBE Program Subcontractor Utilization Form* (§33.302(g)).
- Submit to recipient with its bid package or proposal the completed EPA form number 6100-4, plus an EPA form number 6100-3 for each DBE subcontractor used in the contractor's bid or proposal (§33.302(f) and (g)).
- Pay subcontractors for satisfactory performance no more than 30 days from the prime contractor's receipt of payment from the recipient (§33.302(a)).
- Notify the recipient in writing prior to prime contractor termination of a DBE subcontractor for convenience (§33.302(b)).
- Employ the six good faith efforts described in §33.301 if soliciting a replacement subcontractor after a DBE subcontractor fails to complete work under the subcontract for any reason. (§33.302(c)).
- Employ the six good faith efforts described in §33.301 even if the prime contractor has achieved its fair share objectives under subpart D of Part 33. (§33.302(d)).
- Semiannually inform recipient of DBE participation achieved (§33.502).
- Maintain records documenting its compliance with the requirements of Title 40 Part 33, including documentation of its, and its prime contractors', good faith efforts (§33.501(a)).

Subcontractor Responsibilities:

- May submit EPA form 6100-2 – *DBE Subcontractor Participation Form* to Charles Hayes, EPA Region 4 DBE Coordinator (§33.302(e)).
- Must complete EPA form 6100-3 – *DBE Program Subcontractor Performance Form*, and submit it to the prime contractor soliciting services from the subcontractor prior to the opening of bids for the prime contract.

SPAP Requirements:

Form	Requirement	Provided By:	Completed By:	Submitted To:
EPA Form 6100-2	Grant Recipients required to have prime contractors provide form to Subcontractors	Prime Contractors	DBE Subcontractors	EPA Region 4 DBE Coordinator Charles Hayes
EPA Form 6100-3	Grant Recipients required to have prime contractors provide form to Subcontractors	Prime Contractors	DBE Subcontractors	Grant Recipients as part of a bid or proposal package
EPA Form 6100-4	Grant Recipients required to have prime contractors complete the form	Grant Recipients	Prime Contractors	Grant Recipients as part of a bid or proposal package

SRF Requirements:

Form	Requirement	Provided By:	Completed By:	Submitted To:
EPA Form 6100-2	Recipients required to have prime contractors provide form to Subcontractors	Prime Contractors	DBE Subcontractors	DOW Project Administrator
EPA Form 6100-3	Recipients required to have prime contractors provide form to Subcontractors	Prime Contractors	DBE Subcontractors	Dow Project Administrator w/ATA Package
EPA Form 6100-4	Recipients required to have prime contractors complete the form	Recipients	Prime Contractors	DOW Project Administrator w/ATA Package
Pay Request DBE Form	Recipients required to have prime contractors complete the form	Recipients	Prime Contractors	DOW Project Administrator w/EACH PAYMENT

DISADVANTAGED BUSINESS ENTERPRISE PARTICIPATION POLICY

PROJECT NAME: _____ **BID DATE:** _____

1. Name, address and telephone number of contact person on all DBE matters:

Prime Contractor's Name: _____
Contact Person: _____
Address: _____
Phone: _____
Cell Phone: _____
Email: _____
Total Contract Amount: _____

2. Total dollar amount/percent of contract of MBE participation: _____

3. Total dollar amount/percent of contract of WBE participation: _____

4. Are certifications* for each MBE/WBE/DBE subcontractor enclosed; if no, please explain: Yes No

5. Are MBE/WBE/DBE subcontracts or letters of intent signed by both parties enclosed; if no, please explain: Yes No

6. List of MBE Subcontractors:

Name: _____
Contact Person: _____
Address: _____
Phone: _____
Cell Phone: _____
Email: _____
Type of Contract: _____
Work to be Done: _____
Amount: _____

7. List of WBE Subcontractors:

Name: _____
Contact Person: _____
Address: _____
Phone: _____
Cell Phone: _____
Email: _____
Type of Contract: _____
Work to be Done: _____
Amount: _____

Attach Additional Sheets, If Necessary

*Self-certification: Self certification of MBE/WBE/DBE firms will NOT be accepted as a valid form of certification of MBE/WBE/DBE status.

8. **Information and documentation concerning efforts taken to comply with EPA's "six good faith efforts"**

(i). Ensure DBE construction firms or material suppliers are made aware of contracting opportunities to the fullest extent practicable through outreach and recruitment activities; including placing DBEs on solicitation lists and soliciting them whenever they are potential sources. A good source for a list of DBEs is the Kentucky Transportation's website: <http://transportation.ky.gov/Civil-Rights-and-Small-Business-Development/Pages/Certified-DBE-Directory.aspx>.

The prime contractor certifies that a bidders list (see example sheet below) of qualified vendors, including DBEs, was developed for current and future solicitations and that the list will be maintained. *Submit a copy of the list as documentation.*

(ii). Make information on forthcoming opportunities available to DBEs and arrange time frames for contracts and establish delivery schedules, where the requirements permit, in a way that encourages and facilitates participation by DBEs in the competitive process; including, whenever possible, posting solicitation for bids or proposals for a sufficient amount of time as to receive a competitive bid or proposal pool.

The prime contractor certifies that every opportunity was provided to a number of DBEs to encourage their participation in the competitive process and that an adequate amount of time was provided for response.

a. List each DBE construction firm or material supplier to which a solicitation was attempted. *Submit copies of letters, emails, faxes, telecommunication logs, certified mail receipts, returned envelopes, certified mail return receipts, etc. as documentation.*

Company name and phone number: _____

Area of work expertise: _____

Date of any follow-ups and person spoke to: _____

b. Advertisements, if applicable: List each publication in which an announcement or notification was placed. *Submit a tear sheet of each announcement from each publication as documentation.*

Name of publication: _____

Date(s) of advertisement: _____

Specific subcontract areas announced: _____

c. Other, if applicable: List each notification method in which an announcement or outreach was used; list serve, public meeting, etc. *Submit applicable information to document effort.*

Method of notification: _____

Date(s) of notification: _____

(iii). Consider in the contracting process whether firms competing for large contracts could subcontract with DBEs; including dividing total requirements, when economically feasible, into smaller tasks or quantities to permit maximum participation by DBEs in the competitive process.

The prime contractor certifies that the project was broken into its basic elements (i.e., dirt hauling, landscaping, painting, pipe installation, material supplies, etc.) and that a determination was made whether it's economically feasible to bid the elements separately and that the analysis of this effort was documented with a short memo to the project file.

- (iv). Establishing delivery schedules, where the requirement permits, which encourage participation by small and minority business, and women’s business enterprises.
- The prime contractor certifies that they established delivery schedules which would allow DBEs to participate in the projects.
- (v). Use the services and assistance of the Small Business Administration (SBA) and the Minority Business Development Agency (MBDA) of the U.S. Department of Commerce. The easiest way to utilize the services of SBA and MBDA is to visit their websites: www.sba.gov and www.mbda.gov and use the electronic tools available there or you may send the nearest SBA and MBDA office a certified letter that generally describes the solicitation, the dates it will be open, the types of vendors you are seeking and applicable SIC or NAIC codes if known. You may also use the services and assistance of the Procurement Technical Assistance Center (PTAC). The easiest way to utilize the services of PTAC is to send an email: ptac@ksbdc.org and generally describe the solicitation, the dates it will be open, the types of vendors you are seeking and applicable SIC or NAIC codes if known.
- The prime contractor certifies that the assistance of the SBA, MBDA, and/or PTAC was utilized. *Submit pages printed off the SBA and MBDA websites which evidence efforts to register a solicitation on those sites or submit copies of the letter sent and certified mail receipt as documentation; submit copies of emails with PTAC as documentation.*
- (vi). If a subcontractor awards any subcontracts, require the subcontractor to take the steps in numbers (i) through (v) above.
- The prime contractor certifies that subcontractors used for this project will be required to follow the steps of the “six good faith efforts” as listed above.

9. Signature and date:

To the best of my knowledge and belief, all “six good faith efforts” have been met and the information contained in this document is true and correct; the document has been duly authorized by the legal representative.

Signature

Print name and title

Date

Attachment Number 12

BONDS AND INSURANCE

The minimum requirements shall be as follows:

Bonding requirements for contracts of \$100,000 or less are contained in 40 CFR 31.36(h).

Bond requirements for contracts in excess of \$100,000 are:

- Bid guarantee equivalent to five percent of the bid price. The bid guarantee shall consist of a firm commitment such as a certified check or bid bond submitted with the bid;
- Performance bond equal to 100 percent of the contract price, and
- Payment bond equal to 100 percent of the contract price. Bonds must be obtained from companies holding Certificates of Authority as acceptable sureties, issued by the U.S. Treasury.

Insurance requirements are contained in the General Conditions of the contract. In addition to the other required insurance, the owner or the contractor, as appropriate, must acquire any flood insurance made available by the Federal Emergency Management Agency as required by 44 CFR Parts 59-79, if construction will take place in a flood hazard area identified by the Federal Emergency Management Agency. The owner's requirements on Flood Insurance are contained in the Special Conditions Section of the Contracts Documents.

Attachment Number 13

NOTICE OF INTENT

All construction projects with surface disturbance of more than 1 acre during the period of construction must have a KPDES Storm Water General Permit. The permit can be found at the following web address:

<https://dep.gateway.ky.gov/eForms/default.aspx?FormID=7>.

If you have any questions regarding the completion of this form call the Surface Water Permits Branch, at (502) 564-3410.

Davis-Bacon Wage Rate Requirements

CWSRF: The recipient agrees to include in all agreements to provide assistance for the construction of treatment works carried out in whole or in part with such assistance made available by a State water pollution control revolving fund as authorized by title VI of the Federal Water Pollution Control Act (33 U.S.C. 1381 et seq.), or with such assistance made available under section 205(m) of that Act (33 U.S.C. 1285(m)), or both, a term and condition requiring compliance with the requirements of section 513 of that Act (33 U.S.C. 1372) in all procurement contracts and sub-grants, and require that loan recipients, procurement contractors and sub-grantees include such a term and condition in subcontracts and other lower tiered transactions. All contracts and subcontracts for the construction of treatment works carried out in whole or in part with assistance made available as stated herein shall insert in full in any contract in excess of \$2,000 the contract clauses as set forth below titled “Wage Rate Requirements Under The Consolidated and Further Continuing Appropriations Act, 2013 (P.L. 113-6)”. This term and condition applies to all agreements to provide assistance under the authorities referenced herein, whether in the form of a loan, bond purchase, grant, or any other vehicle to provide financing for a project, where such agreements are executed on or after October 30, 2009.

DWSRF: The recipient agrees to include in all agreements to provide assistance for any construction project carried out in whole or in part with such assistance made available by a drinking water treatment revolving loan fund as authorized by section 1452 of the Safe Drinking Water Act (42 U.S.C. 300j-12), a term and condition requiring compliance with the requirements of section 1450(e) of the Safe Drinking Water Act (42 U.S.C.300j-9(e)) in all procurement contracts and sub-grants, and require that loan recipients, procurement contractors and sub-grantees include such a term and condition in subcontracts and other lower tiered transactions All contracts and subcontracts for any construction project carried out in whole or in part with assistance made available as stated herein shall insert in full in any contract in excess of \$2,000 the contract clauses as set forth below entitled “Wage Rate Requirements Under The Consolidated and Further Continuing Appropriations Act, 2013 (P.L. 113-6)”. This term and condition applies to all agreements to provide assistance under the authorities referenced herein, whether in the form of a loan, bond purchase, grant, or any other vehicle to provide financing for a project, where such agreements are executed on or after October 30, 2009.

Wage Rate Requirements Under The Consolidated and Further Continuing Appropriations Act, 2013 (P.L. 113-6)

Preamble

With respect to the Clean Water and Safe Drinking Water State Revolving Funds, EPA provides capitalization grants to each State which in turn provides subgrants or loans to eligible entities within the State. Typically, the subrecipients are municipal or other local governmental entities that manage the funds. For these types of recipients, the provisions set forth under Roman Numeral I, below, shall apply. Although EPA and the State remain responsible for ensuring subrecipients’ compliance with the wage rate requirements set forth herein, those subrecipients shall have the primary responsibility to maintain payroll records as described in Section 3(ii)(A), below and for compliance as described in Section I-5.

Occasionally, the subrecipient may be a private for profit or not for profit entity. For these types of recipients, the provisions set forth in Roman Numeral II, below, shall apply. Although EPA and the State remain responsible for ensuring subrecipients' compliance with the wage rate requirements set forth herein, those subrecipients shall have the primary responsibility to maintain payroll records as described in Section II-3(ii)(A), below and for compliance as described in Section II-5.

I. Requirements Under The Consolidated and Further Continuing Appropriations Act, 2013 (P.L. 113-6) For Subrecipients That Are Governmental Entities:

The following terms and conditions specify how recipients will assist EPA in meeting its Davis-Bacon (DB) responsibilities when DB applies to EPA awards of financial assistance under the FY 2013 Continuing Resolution with respect to State recipients and subrecipients that are governmental entities. If a subrecipient has questions regarding when DB applies, obtaining the correct DB wage determinations, DB provisions, or compliance monitoring, it may contact the State recipient. The recipient or subrecipient may also obtain additional guidance from DOL's website at <http://www.dol.gov/whd/>

1. Applicability of the Davis- Bacon (DB) prevailing wage requirements.

Under the FY 2013 Continuing Resolution, DB prevailing wage requirements apply to the construction, alteration, and repair of treatment works carried out in whole or in part with assistance made available by a State water pollution control revolving fund and to any construction project carried out in whole or in part by assistance made available by a drinking water treatment revolving loan fund. If a subrecipient encounters a unique situation at a site that presents uncertainties regarding DB applicability, the subrecipient must discuss the situation with the recipient State before authorizing work on that site.

2. Obtaining Wage Determinations.

(a) Subrecipients shall obtain the wage determination for the locality in which a covered activity subject to DB will take place prior to issuing requests for bids, proposals, quotes or other methods for soliciting contracts (solicitation) for activities subject to DB. These wage determinations shall be incorporated into solicitations and any subsequent contracts. Prime contracts must contain a provision requiring that subcontractors follow the wage determination incorporated into the prime contract.

(i) While the solicitation remains open, the subrecipient shall monitor www.wdol.gov weekly to ensure that the wage determination contained in the solicitation remains current. The subrecipients shall amend the solicitation if DOL issues a modification more than 10 days prior to the closing date (i.e. bid opening) for the solicitation. If DOL modifies or supersedes the applicable wage determination less than 10 days prior to the closing date, the subrecipients may request a finding from the State recipient that there is not a reasonable time to notify interested contractors of the modification of the wage determination. The State recipient will provide a report of its findings to the subrecipient.

(ii) If the subrecipient does not award the contract within 90 days of the closure of the solicitation, any modifications or supersedes DOL makes to the wage determination contained in the solicitation shall be effective unless the State recipient, at the request of the subrecipient, obtains an extension of the 90 day period from DOL pursuant to 29 CFR 1.6(c)(3)(iv). The subrecipient shall monitor www.wdol.gov on a weekly basis if it does not award the contract within 90 days of closure of the solicitation to ensure that wage determinations contained in the solicitation remain current.

(b) If the subrecipient carries out activity subject to DB by issuing a task order, work assignment or similar instrument to an existing contractor (ordering instrument) rather than by publishing a solicitation, the subrecipient shall insert the appropriate DOL wage determination from www.wdol.gov into the ordering instrument.

(c) Subrecipients shall review all subcontracts subject to DB entered into by prime contractors to verify that the prime contractor has required its subcontractors to include the applicable wage determinations.

(d) As provided in 29 CFR 1.6(f), DOL may issue a revised wage determination applicable to a subrecipient's contract after the award of a contract or the issuance of an ordering instrument if DOL determines that the subrecipient has failed to incorporate a wage determination or has used a wage determination that clearly does not apply to the contract or ordering instrument. If this occurs, the subrecipient shall either terminate the contract or ordering instrument and issue a revised solicitation or ordering instrument or incorporate DOL's wage determination retroactive to the beginning of the contract or ordering instrument by change order. The subrecipient's contractor must be compensated for any increases in wages resulting from the use of DOL's revised wage determination.

3. Contract and Subcontract provisions.

(a) The Recipient shall insure that the subrecipient(s) shall insert in full in any contract in excess of \$2,000 which is entered into for the actual construction, alteration and/or repair, including painting and decorating, of a treatment work under the CWSRF or a construction project under the DWSRF financed in whole or in part from Federal funds or in accordance with guarantees of a Federal agency or financed from funds obtained by pledge of any contract of a Federal agency to make a loan, grant or annual contribution (except where a different meaning is expressly indicated), and which is subject to the labor standards provisions of any of the acts listed in § 5.1 or the FY 2013 Continuing Resolution, the following clauses:

(1) Minimum wages.

(i) All laborers and mechanics employed or working upon the site of the work will be paid unconditionally and not less often than once a week, and without subsequent deduction or rebate on any account (except such payroll deductions as are permitted by regulations issued by the Secretary of Labor under the Copeland Act (29 CFR part 3)), the full amount of wages and bona fide fringe benefits (or cash equivalents thereof) due at time of payment computed at rates not less than those contained in the wage determination of the Secretary of Labor which is attached hereto and made a part hereof, regardless of any contractual relationship which may be alleged to exist between the contractor and such laborers and mechanics.

Contributions made or costs reasonably anticipated for bona fide fringe benefits under section 1(b)(2) of the Davis-Bacon Act on behalf of laborers or mechanics are considered wages paid to such laborers or mechanics, subject to the provisions of paragraph (a)(1)(iv) of this section; also, regular contributions made or costs incurred for more than a weekly period (but not less often than quarterly) under plans, funds, or programs which cover the particular weekly period, are deemed to be constructively made or incurred during such weekly period. Such laborers and mechanics shall be paid the appropriate wage rate and fringe benefits on the wage determination for the classification of work actually performed, without regard to skill, except as provided in § 5.5(a)(4). Laborers or mechanics performing work in more than one classification may be compensated at the rate specified for each classification for the time actually worked therein: Provided, that the employer's payroll records accurately set forth the time spent in each classification in which work is performed. The wage determination (including any additional classification and wage rates conformed under paragraph (a)(1)(ii) of this section) and the Davis-Bacon poster (WH-1321) shall be posted at all times by the contractor and its subcontractors at the site of the work in a prominent and accessible place where it can be easily seen by the workers.

Subrecipients may obtain wage determinations from the U.S. Department of Labor's website, www.dol.gov.

(ii)(A) The subrecipient(s), on behalf of EPA, shall require that any class of laborers or mechanics, including helpers, which is not listed in the wage determination and which is to be employed under the contract shall be classified in conformance with the wage determination. The State award official shall approve a request for an additional classification and wage rate and fringe benefits therefore only when the following criteria have been met:

(1) The work to be performed by the classification requested is not performed by a classification in the wage determination; and

(2) The classification is utilized in the area by the construction industry; and

(3) The proposed wage rate, including any bona fide fringe benefits, bears a reasonable relationship to the wage rates contained in the wage determination.

(B) If the contractor and the laborers and mechanics to be employed in the classification (if known), or their representatives, and the subrecipient(s) agree on the classification and wage rate (including the amount designated for fringe benefits where appropriate), documentation of the action taken and the request, including the local wage determination shall be sent by the subrecipient (s) to the State award official. The State award official will transmit the request, to the Administrator of the Wage and Hour Division, Employment Standards Administration, U.S. Department of Labor, Washington, DC 20210 and to the EPA DB Regional Coordinator concurrently. The Administrator, or an authorized representative, will approve, modify, or disapprove every additional classification request within 30 days of receipt and so advise the State award official or will notify the State award official within the 30-day period that additional time is necessary.

(C) In the event the contractor, the laborers or mechanics to be employed in the classification or their representatives, and the subrecipient(s) do not agree on the proposed classification and wage rate (including the amount designated for fringe benefits, where appropriate), the award official shall refer the request and the local wage determination, including the views of all

interested parties and the recommendation of the State award official, to the Administrator for determination. The request shall be sent to the EPA DB Regional Coordinator concurrently. The Administrator, or an authorized representative, will issue a determination within 30 days of receipt of the request and so advise the contracting officer or will notify the contracting officer within the 30-day period that additional time is necessary.

(D) The wage rate (including fringe benefits where appropriate) determined pursuant to paragraphs (a)(1)(ii)(B) or (C) of this section, shall be paid to all workers performing work in the classification under this contract from the first day on which work is performed in the classification.

(iii) Whenever the minimum wage rate prescribed in the contract for a class of laborers or mechanics includes a fringe benefit which is not expressed as an hourly rate, the contractor shall either pay the benefit as stated in the wage determination or shall pay another bona fide fringe benefit or an hourly cash equivalent thereof.

(iv) If the contractor does not make payments to a trustee or other third person, the contractor may consider as part of the wages of any laborer or mechanic the amount of any costs reasonably anticipated in providing bona fide fringe benefits under a plan or program, Provided, That the Secretary of Labor has found, upon the written request of the contractor, that the applicable standards of the Davis-Bacon Act have been met. The Secretary of Labor may require the contractor to set aside in a separate account assets for the meeting of obligations under the plan or program.

(2) Withholding. The subrecipient(s), shall upon written request of the EPA Award Official or an authorized representative of the Department of Labor, withhold or cause to be withheld from the contractor under this contract or any other Federal contract with the same prime contractor, or any other federally-assisted contract subject to Davis-Bacon prevailing wage requirements, which is held by the same prime contractor, so much of the accrued payments or advances as may be considered necessary to pay laborers and mechanics, including apprentices, trainees, and helpers, employed by the contractor or any subcontractor the full amount of wages required by the contract. In the event of failure to pay any laborer or mechanic, including any apprentice, trainee, or helper, employed or working on the site of the work, all or part of the wages required by the contract, the (Agency) may, after written notice to the contractor, sponsor, applicant, or owner, take such action as may be necessary to cause the suspension of any further payment, advance, or guarantee of funds until such violations have ceased.

(3) Payrolls and basic records.

(i) Payrolls and basic records relating thereto shall be maintained by the contractor during the course of the work and preserved for a period of three years thereafter for all laborers and mechanics working at the site of the work. Such records shall contain the name, address, and social security number of each such worker, his or her correct classification, hourly rates of wages paid (including rates of contributions or costs anticipated for bona fide fringe benefits or cash equivalents thereof of the types described in section 1(b)(2)(B) of the Davis-Bacon Act), daily and weekly number of hours worked, deductions made and actual wages paid. Whenever the Secretary of Labor has found under 29 CFR 5.5(a)(1)(iv) that the wages of any laborer or mechanic include the amount of any costs reasonably anticipated in providing benefits under a plan or program described in section 1(b)(2)(B) of the Davis-Bacon Act, the contractor shall maintain records which show that the commitment to provide such benefits is enforceable, that

the plan or program is financially responsible, and that the plan or program has been communicated in writing to the laborers or mechanics affected, and records which show the costs anticipated or the actual cost incurred in providing such benefits. Contractors employing apprentices or trainees under approved programs shall maintain written evidence of the registration of apprenticeship programs and certification of trainee programs, the registration of the apprentices and trainees, and the ratios and wage rates prescribed in the applicable programs.

(ii)(A) The contractor shall submit weekly, for each week in which any contract work is performed, a copy of all payrolls to the subrecipient, that is, the entity that receives the sub-grant or loan from the State capitalization grant recipient. Such documentation shall be available on request of the State recipient or EPA. As to each payroll copy received, the subrecipient shall provide written confirmation in a form satisfactory to the State indicating whether or not the project is in compliance with the requirements of 29 CFR 5.5(a)(1) based on the most recent payroll copies for the specified week. The payrolls shall set out accurately and completely all of the information required to be maintained under 29 CFR 5.5(a)(3)(i), except that full social security numbers and home addresses shall not be included on the weekly payrolls. Instead the payrolls shall only need to include an individually identifying number for each employee (e.g., the last four digits of the employee's social security number). The required weekly payroll information may be submitted in any form desired. Optional Form WH-347 is available for this purpose from the Wage and Hour Division Web site at <http://www.dol.gov/whd/forms/wh347instr.htm> or its successor site. The prime contractor is responsible for the submission of copies of payrolls by all subcontractors. Contractors and subcontractors shall maintain the full social security number and current address of each covered worker, and shall provide them upon request to the subrecipient(s) for transmission to the State or EPA if requested by EPA, the State, the contractor, or the Wage and Hour Division of the Department of Labor for purposes of an investigation or audit of compliance with prevailing wage requirements. It is not a violation of this section for a prime contractor to require a subcontractor to provide addresses and social security numbers to the prime contractor for its own records, without weekly submission to the subrecipient(s).

(B) Each payroll submitted shall be accompanied by a "Statement of Compliance," signed by the contractor or subcontractor or his or her agent who pays or supervises the payment of the persons employed under the contract and shall certify the following:

(1) That the payroll for the payroll period contains the information required to be provided under §5.5 (a)(3)(ii) of Regulations, 29 CFR part 5, the appropriate information is being maintained under §5.5 (a)(3)(i) of Regulations, 29 CFR part 5, and that such information is correct and complete;

(2) That each laborer or mechanic (including each helper, apprentice, and trainee) employed on the contract during the payroll period has been paid the full weekly wages earned, without rebate, either directly or indirectly, and that no deductions have been made either directly or indirectly from the full wages earned, other than permissible deductions as set forth in Regulations, 29 CFR part 3;

(3) That each laborer or mechanic has been paid not less than the applicable wage rates and fringe benefits or cash equivalents for the classification of work performed, as specified in the applicable wage determination incorporated into the contract.

(C) The weekly submission of a properly executed certification set forth on the reverse side of Optional Form WH-347 shall satisfy the requirement for submission of the "Statement of Compliance" required by paragraph (a)(3)(ii)(B) of this section.

(D) The falsification of any of the above certifications may subject the contractor or subcontractor to civil or criminal prosecution under section 1001 of title 18 and section 231 of title 31 of the United States Code.

(iii) The contractor or subcontractor shall make the records required under paragraph (a)(3)(i) of this section available for inspection, copying, or transcription by authorized representatives of the State, EPA or the Department of Labor, and shall permit such representatives to interview employees during working hours on the job. If the contractor or subcontractor fails to submit the required records or to make them available, the Federal agency or State may, after written notice to the contractor, sponsor, applicant, or owner, take such action as may be necessary to cause the suspension of any further payment, advance, or guarantee of funds. Furthermore, failure to submit the required records upon request or to make such records available may be grounds for debarment action pursuant to 29 CFR 5.12.

(4) Apprentices and trainees.

(i) Apprentices. Apprentices will be permitted to work at less than the predetermined rate for the work they performed when they are employed pursuant to and individually registered in a bona fide apprenticeship program registered with the U.S. Department of Labor, Employment and Training Administration, Office of Apprenticeship Training, Employer and Labor Services, or with a State Apprenticeship Agency recognized by the Office, or if a person is employed in his or her first 90 days of probationary employment as an apprentice in such an apprenticeship program, who is not individually registered in the program, but who has been certified by the Office of Apprenticeship Training, Employer and Labor Services or a State Apprenticeship Agency (where appropriate) to be eligible for probationary employment as an apprentice. The allowable ratio of apprentices to journeymen on the job site in any craft classification shall not be greater than the ratio permitted to the contractor as to the entire work force under the registered program. Any worker listed on a payroll at an apprentice wage rate, who is not registered or otherwise employed as stated above, shall be paid not less than the applicable wage rate on the wage determination for the classification of work actually performed. In addition, any apprentice performing work on the job site in excess of the ratio permitted under the registered program shall be paid not less than the applicable wage rate on the wage determination for the work actually performed. Where a contractor is performing construction on a project in a locality other than that in which its program is registered, the ratios and wage rates (expressed in percentages of the journeyman's hourly rate) specified in the contractor's or subcontractor's registered program shall be observed. Every apprentice must be paid at not less than the rate specified in the registered program for the apprentice's level of progress, expressed as a percentage of the journeymen hourly rate specified in the applicable wage determination. Apprentices shall be paid fringe benefits in accordance with the provisions of the apprenticeship program. If the apprenticeship program does not specify fringe benefits, apprentices must be paid the full amount of fringe benefits listed on the wage determination for the applicable classification. If the Administrator determines that a different practice prevails for the applicable apprentice classification, fringes shall be paid in accordance with that determination. In the event the Office of Apprenticeship Training, Employer and Labor Services, or a State Apprenticeship Agency recognized by the Office, withdraws approval of an apprenticeship program, the contractor will

no longer be permitted to utilize apprentices at less than the applicable predetermined rate for the work performed until an acceptable program is approved.

(ii) Trainees. Except as provided in 29 CFR 5.16, trainees will not be permitted to work at less than the predetermined rate for the work performed unless they are employed pursuant to and individually registered in a program which has received prior approval, evidenced by formal certification by the U.S. Department of Labor, Employment and Training Administration. The ratio of trainees to journeymen on the job site shall not be greater than permitted under the plan approved by the Employment and Training Administration. Every trainee must be paid at not less than the rate specified in the approved program for the trainee's level of progress, expressed as a percentage of the journeyman hourly rate specified in the applicable wage determination. Trainees shall be paid fringe benefits in accordance with the provisions of the trainee program. If the trainee program does not mention fringe benefits, trainees shall be paid the full amount of fringe benefits listed on the wage determination unless the Administrator of the Wage and Hour Division determines that there is an apprenticeship program associated with the corresponding journeyman wage rate on the wage determination which provides for less than full fringe benefits for apprentices. Any employee listed on the payroll at a trainee rate who is not registered and participating in a training plan approved by the Employment and Training Administration shall be paid not less than the applicable wage rate on the wage determination for the classification of work actually performed. In addition, any trainee performing work on the job site in excess of the ratio permitted under the registered program shall be paid not less than the applicable wage rate on the wage determination for the work actually performed. In the event the Employment and Training Administration withdraws approval of a training program, the contractor will no longer be permitted to utilize trainees at less than the applicable predetermined rate for the work performed until an acceptable program is approved.

(iii) Equal employment opportunity. The utilization of apprentices, trainees and journeymen under this part shall be in conformity with the equal employment opportunity requirements of Executive Order 11246, as amended, and 29 CFR part 30.

(5) Compliance with Copeland Act requirements. The contractor shall comply with the requirements of 29 CFR part 3, which are incorporated by reference in this contract.

(6) Subcontracts. The contractor or subcontractor shall insert in any subcontracts the clauses contained in 29 CFR 5.5(a)(1) through (10) and such other clauses as the EPA determines may be appropriate, and also a clause requiring the subcontractors to include these clauses in any lower tier subcontracts. The prime contractor shall be responsible for the compliance by any subcontractor or lower tier subcontractor with all the contract clauses in 29 CFR 5.5.

(7) Contract termination; debarment. A breach of the contract clauses in 29 CFR 5.5 may be grounds for termination of the contract, and for debarment as a contractor and a subcontractor as provided in 29 CFR 5.12.

(8) Compliance with Davis-Bacon and Related Act requirements. All rulings and interpretations of the Davis-Bacon and Related Acts contained in 29 CFR parts 1, 3, and 5 are herein incorporated by reference in this contract.

(9) Disputes concerning labor standards. Disputes arising out of the labor standards provisions of this contract shall not be subject to the general disputes clause of this contract. Such disputes shall be resolved in accordance with the procedures of the Department of Labor set forth in 29

CFR parts 5, 6, and 7. Disputes within the meaning of this clause include disputes between the contractor (or any of its subcontractors) and Subrecipient(s), State, EPA, the U.S. Department of Labor, or the employees or their representatives.

(10) Certification of eligibility.

(i) By entering into this contract, the contractor certifies that neither it (nor he or she) nor any person or firm who has an interest in the contractor's firm is a person or firm ineligible to be awarded Government contracts by virtue of section 3(a) of the Davis-Bacon Act or 29 CFR 5.12(a)(1).

(ii) No part of this contract shall be subcontracted to any person or firm ineligible for award of a Government contract by virtue of section 3(a) of the Davis-Bacon Act or 29 CFR 5.12(a)(1).

(iii) The penalty for making false statements is prescribed in the U.S. Criminal Code, 18 U.S.C. 1001.

4. Contract Provision for Contracts in Excess of \$100,000.

(a) Contract Work Hours and Safety Standards Act. The subrecipient shall insert the following clauses set forth in paragraphs (a)(1), (2), (3), and (4) of this section in full in any contract in an amount in excess of \$100,000 and subject to the overtime provisions of the Contract Work Hours and Safety Standards Act. These clauses shall be inserted in addition to the clauses required by Item 3, above or 29 CFR 4.6. As used in this paragraph, the terms laborers and mechanics include watchmen and guards.

(1) Overtime requirements. No contractor or subcontractor contracting for any part of the contract work which may require or involve the employment of laborers or mechanics shall require or permit any such laborer or mechanic in any workweek in which he or she is employed on such work to work in excess of forty hours in such workweek unless such laborer or mechanic receives compensation at a rate not less than one and one-half times the basic rate of pay for all hours worked in excess of forty hours in such workweek.

(2) Violation; liability for unpaid wages; liquidated damages. In the event of any violation of the clause set forth in paragraph (a)(1) of this section the contractor and any subcontractor responsible therefore shall be liable for the unpaid wages. In addition, such contractor and subcontractor shall be liable to the United States (in the case of work done under contract for the District of Columbia or a territory, to such District or to such territory), for liquidated damages. Such liquidated damages shall be computed with respect to each individual laborer or mechanic, including watchmen and guards, employed in violation of the clause set forth in paragraph (a)(1) of this section, in the sum of \$10 for each calendar day on which such individual was required or permitted to work in excess of the standard workweek of forty hours without payment of the overtime wages required by the clause set forth in paragraph (a)(1) of this section.

(3) Withholding for unpaid wages and liquidated damages. The subrecipient, upon written request of the EPA Award Official or an authorized representative of the Department of Labor, shall withhold or cause to be withheld, from any moneys payable on account of work performed by the contractor or subcontractor under any such contract or any other Federal contract with the same prime contractor, or any other federally-assisted contract subject to the Contract Work Hours and Safety Standards Act, which is held by the same prime contractor, such sums as may

be determined to be necessary to satisfy any liabilities of such contractor or subcontractor for unpaid wages and liquidated damages as provided in the clause set forth in paragraph (b)(2) of this section.

(4) Subcontracts. The contractor or subcontractor shall insert in any subcontracts the clauses set forth in paragraph (a)(1) through (4) of this section and also a clause requiring the subcontractors to include these clauses in any lower tier subcontracts. The prime contractor shall be responsible for compliance by any subcontractor or lower tier subcontractor with the clauses set forth in paragraphs (a)(1) through (4) of this section.

(b) In addition to the clauses contained in Item 3, above, in any contract subject only to the Contract Work Hours and Safety Standards Act and not to any of the other statutes cited in 29 CFR 5.1, the Subrecipient shall insert a clause requiring that the contractor or subcontractor shall maintain payrolls and basic payroll records during the course of the work and shall preserve them for a period of three years from the completion of the contract for all laborers and mechanics, including guards and watchmen, working on the contract. Such records shall contain the name and address of each such employee, social security number, correct classifications, hourly rates of wages paid, daily and weekly number of hours worked, deductions made, and actual wages paid. Further, the Subrecipient shall insert in any such contract a clause providing that the records to be maintained under this paragraph shall be made available by the contractor or subcontractor for inspection, copying, or transcription by authorized representatives of the (write the name of agency) and the Department of Labor, and the contractor or subcontractor will permit such representatives to interview employees during working hours on the job.

5. Compliance Verification.

(a) The subrecipient shall periodically interview a sufficient number of employees entitled to DB prevailing wages (covered employees) to verify that contractors or subcontractors are paying the appropriate wage rates. As provided in 29 CFR 5.6(a)(6), all interviews must be conducted in confidence. The subrecipient must use Standard Form 1445 (SF 1445) or equivalent documentation to memorialize the interviews. Copies of the SF 1445 are available from EPA on request.

(b) The subrecipient shall establish and follow an interview schedule based on its assessment of the risks of noncompliance with DB posed by contractors or subcontractors and the duration of the contract or subcontract. Subrecipients must conduct more frequent interviews if the initial interviews or other information indicates that there is a risk that the contractor or subcontractor is not complying with DB . Subrecipients shall immediately conduct necessary interviews in response to an alleged violation of the prevailing wage requirements. All interviews shall be conducted in confidence.

(c) The subrecipient shall periodically conduct spot checks of a representative sample of weekly payroll data to verify that contractors or subcontractors are paying the appropriate wage rates. The subrecipient shall establish and follow a spot check schedule based on its assessment of the risks of noncompliance with DB posed by contractors or subcontractors and the duration of the contract or subcontract. At a minimum, if practicable, the subrecipient should spot check payroll data within two weeks of each contractor or subcontractor's submission of its initial payroll data and two weeks prior to the completion date the contract or subcontract. Subrecipients must conduct more frequent spot checks if the initial spot check or other information indicates that there is a risk that the contractor or subcontractor is not complying with DB. In addition, during

the examinations the subrecipient shall verify evidence of fringe benefit plans and payments thereunder by contractors and subcontractors who claim credit for fringe benefit contributions.

(d) The subrecipient shall periodically review contractors and subcontractor's use of apprentices and trainees to verify registration and certification with respect to apprenticeship and training programs approved by either the U.S Department of Labor or a state, as appropriate, and that contractors and subcontractors are not using disproportionate numbers of, laborers, trainees and apprentices. These reviews shall be conducted in accordance with the schedules for spot checks and interviews described in Item 5(b) and (c) above.

(e) Subrecipients must immediately report potential violations of the DB prevailing wage requirements to the EPA DB contact listed above and to the appropriate DOL Wage and Hour District Office listed at <http://www.dol.gov/contacts/whd/america2.htm>.

II. Requirements Under The Consolidated and further Continuing Appropriations Act, 2013 (P.L. 113-6) For Subrecipients That Are Not Governmental Agencies

The following terms and conditions specify how recipients will assist EPA in meeting its DB responsibilities when DB applies to EPA awards of financial assistance under the FY2013 Continuing Resolution with respect to subrecipients that are not governmental entities. If a subrecipient has questions regarding when DB applies, obtaining the correct DB wage determinations, DB provisions, or compliance monitoring, it may contact the State recipient for guidance. The recipient or subrecipient may also obtain additional guidance from DOL's web site at <http://www.dol.gov/whd/>.

Under these terms and conditions, the subrecipient must submit its proposed DB wage determinations to the State recipient for approval prior to including the wage determination in any solicitation, contract task orders, work assignments, or similar instruments to existing contractors.

1. Applicability of the Davis- Bacon (DB) prevailing wage requirements.

Under the FY 2013 Continuing Resolution, Davis-Bacon prevailing wage requirements apply to the construction, alteration, and repair of treatment works carried out in whole or in part with assistance made available by a State water pollution control revolving fund and to any construction project carried out in whole or in part by assistance made available by a drinking water treatment revolving loan fund. If a subrecipient encounters a unique situation at a site that presents uncertainties regarding DB applicability, the subrecipient must discuss the situation with the recipient State before authorizing work on that site.

2. Obtaining Wage Determinations.

(a) Subrecipients must obtain proposed wage determinations for specific localities at www.wdol.gov. After the Subrecipient obtains its proposed wage determination, it must submit the wage determination to (insert contact information for State recipient DB point of contact for wage determination) for approval prior to inserting the wage determination into a solicitation, contract or issuing task orders, work assignments or similar instruments to existing contractors

(ordering instruments unless subsequently directed otherwise by the State recipient Award Official).

(b) Subrecipients shall obtain the wage determination for the locality in which a covered activity subject to DB will take place prior to issuing requests for bids, proposals, quotes or other methods for soliciting contracts (solicitation) for activities subject to DB. These wage determinations shall be incorporated into solicitations and any subsequent contracts. Prime contracts must contain a provision requiring that subcontractors follow the wage determination incorporated into the prime contract.

(i) While the solicitation remains open, the subrecipient shall monitor www.wdol.gov on a weekly basis to ensure that the wage determination contained in the solicitation remains current. The subrecipients shall amend the solicitation if DOL issues a modification more than 10 days prior to the closing date (i.e. bid opening) for the solicitation. If DOL modifies or supersedes the applicable wage determination less than 10 days prior to the closing date, the subrecipients may request a finding from the State recipient that there is not a reasonable time to notify interested contractors of the modification of the wage determination. The State recipient will provide a report of its findings to the subrecipient.

(ii) If the subrecipient does not award the contract within 90 days of the closure of the solicitation, any modifications or supersedes DOL makes to the wage determination contained in the solicitation shall be effective unless the State recipient, at the request of the subrecipient, obtains an extension of the 90 day period from DOL pursuant to 29 CFR 1.6(c)(3)(iv). The subrecipient shall monitor www.wdol.gov on a weekly basis if it does not award the contract within 90 days of closure of the solicitation to ensure that wage determinations contained in the solicitation remain current.

(c) If the subrecipient carries out activity subject to DB by issuing a task order, work assignment or similar instrument to an existing contractor (ordering instrument) rather than by publishing a solicitation, the subrecipient shall insert the appropriate DOL wage determination from www.wdol.gov into the ordering instrument.

(c) Subrecipients shall review all subcontracts subject to DB entered into by prime contractors to verify that the prime contractor has required its subcontractors to include the applicable wage determinations.

(d) As provided in 29 CFR 1.6(f), DOL may issue a revised wage determination applicable to a subrecipient's contract after the award of a contract or the issuance of an ordering instrument if DOL determines that the subrecipient has failed to incorporate a wage determination or has used a wage determination that clearly does not apply to the contract or ordering instrument. If this occurs, the subrecipient shall either terminate the contract or ordering instrument and issue a revised solicitation or ordering instrument or incorporate DOL's wage determination retroactive to the beginning of the contract or ordering instrument by change order. The subrecipient's contractor must be compensated for any increases in wages resulting from the use of DOL's revised wage determination.

3. Contract and Subcontract provisions.

(a) The Recipient shall insure that the subrecipient(s) shall insert in full in any contract in excess of \$2,000 which is entered into for the actual construction, alteration and/or repair, including

painting and decorating, of a treatment work under the CWSRF or a construction project under the DWSRF financed in whole or in part from Federal funds or in accordance with guarantees of a Federal agency or financed from funds obtained by pledge of any contract of a Federal agency to make a loan, grant or annual contribution (except where a different meaning is expressly indicated), and which is subject to the labor standards provisions of any of the acts listed in § 5.1 or the FY 2013 Continuing Resolution, the following clauses:

(1) Minimum wages.

(i) All laborers and mechanics employed or working upon the site of the work, will be paid unconditionally and not less often than once a week, and without subsequent deduction or rebate on any account (except such payroll deductions as are permitted by regulations issued by the Secretary of Labor under the Copeland Act (29 CFR part 3)), the full amount of wages and bona fide fringe benefits (or cash equivalents thereof) due at time of payment computed at rates not less than those contained in the wage determination of the Secretary of Labor which is attached hereto and made a part hereof, regardless of any contractual relationship which may be alleged to exist between the contractor and such laborers and mechanics.

Contributions made or costs reasonably anticipated for bona fide fringe benefits under section 1(b)(2) of the Davis-Bacon Act on behalf of laborers or mechanics are considered wages paid to such laborers or mechanics, subject to the provisions of paragraph (a)(1)(iv) of this section; also, regular contributions made or costs incurred for more than a weekly period (but not less often than quarterly) under plans, funds, or programs which cover the particular weekly period, are deemed to be constructively made or incurred during such weekly period. Such laborers and mechanics shall be paid the appropriate wage rate and fringe benefits on the wage determination for the classification of work actually performed, without regard to skill, except as provided in § 5.5(a)(4). Laborers or mechanics performing work in more than one classification may be compensated at the rate specified for each classification for the time actually worked therein: Provided, that the employer's payroll records accurately set forth the time spent in each classification in which work is performed. The wage determination (including any additional classification and wage rates conformed under paragraph (a)(1)(ii) of this section) and the Davis-Bacon poster (WH-1321) shall be posted at all times by the contractor and its subcontractors at the site of the work in a prominent and accessible place where it can be easily seen by the workers.

Subrecipients may obtain wage determinations from the U.S. Department of Labor's web site, www.dol.gov.

(ii)(A) The subrecipient(s), on behalf of EPA, shall require that any class of laborers or mechanics, including helpers, which is not listed in the wage determination and which is to be employed under the contract shall be classified in conformance with the wage determination. The State award official shall approve a request for an additional classification and wage rate and fringe benefits therefore only when the following criteria have been met:

(1) The work to be performed by the classification requested is not performed by a classification in the wage determination; and

(2) The classification is utilized in the area by the construction industry; and

(3) The proposed wage rate, including any bona fide fringe benefits, bears a reasonable relationship to the wage rates contained in the wage determination.

(B) If the contractor and the laborers and mechanics to be employed in the classification (if known), or their representatives, and the subrecipient(s) agree on the classification and wage rate (including the amount designated for fringe benefits where appropriate), documentation of the action taken and the request, including the local wage determination shall be sent by the subrecipient(s) to the State award official. The State award official will transmit the report, to the Administrator of the Wage and Hour Division, Employment Standards Administration, U.S. Department of Labor, Washington, DC 20210 and to the EPA DB Regional Coordinator concurrently. The Administrator, or an authorized representative, will approve, modify, or disapprove every additional classification request within 30 days of receipt and so advise the State award official or will notify the State award official within the 30-day period that additional time is necessary.

(C) In the event the contractor, the laborers or mechanics to be employed in the classification or their representatives, and the and the subrecipient(s) do not agree on the proposed classification and wage rate (including the amount designated for fringe benefits, where appropriate), the award official shall refer the request, and the local wage determination, including the views of all interested parties and the recommendation of the State award official, to the Administrator for determination. The request shall be sent to the EPA Regional Coordinator concurrently. The Administrator, or an authorized representative, will issue a determination within 30 days of receipt of the request and so advise the contracting officer or will notify the contracting officer within the 30-day period that additional time is necessary.

(D) The wage rate (including fringe benefits where appropriate) determined pursuant to paragraphs (a)(1)(ii)(B) or (C) of this section, shall be paid to all workers performing work in the classification under this contract from the first day on which work is performed in the classification.

(iii) Whenever the minimum wage rate prescribed in the contract for a class of laborers or mechanics includes a fringe benefit which is not expressed as an hourly rate, the contractor shall either pay the benefit as stated in the wage determination or shall pay another bona fide fringe benefit or an hourly cash equivalent thereof.

(iv) If the contractor does not make payments to a trustee or other third person, the contractor may consider as part of the wages of any laborer or mechanic the amount of any costs reasonably anticipated in providing bona fide fringe benefits under a plan or program, Provided, That the Secretary of Labor has found, upon the written request of the contractor, that the applicable standards of the Davis-Bacon Act have been met. The Secretary of Labor may require the contractor to set aside in a separate account assets for the meeting of obligations under the plan or program.

(2) Withholding. The subrecipient(s) shall upon written request of the EPA Award Official or an authorized representative of the Department of Labor, withhold or cause to be withheld from the contractor under this contract or any other Federal contract with the same prime contractor, or any other federally-assisted contract subject to Davis-Bacon prevailing wage requirements, which is held by the same prime contractor, so much of the accrued payments or advances as may be considered necessary to pay laborers and mechanics, including apprentices, trainees, and helpers, employed by the contractor or any subcontractor the full amount of wages required by

the contract. In the event of failure to pay any laborer or mechanic, including any apprentice, trainee, or helper, employed or working on the site of the work, all or part of the wages required by the contract, the (Agency) may, after written notice to the contractor, sponsor, applicant, or owner, take such action as may be necessary to cause the suspension of any further payment, advance, or guarantee of funds until such violations have ceased.

(3) Payrolls and basic records.

(i) Payrolls and basic records relating thereto shall be maintained by the contractor during the course of the work and preserved for a period of three years thereafter for all laborers and mechanics working at the site of the work. Such records shall contain the name, address, and social security number of each such worker, his or her correct classification, hourly rates of wages paid (including rates of contributions or costs anticipated for bona fide fringe benefits or cash equivalents thereof of the types described in section 1(b)(2)(B) of the Davis-Bacon Act), daily and weekly number of hours worked, deductions made and actual wages paid. Whenever the Secretary of Labor has found under 29 CFR 5.5(a)(1)(iv) that the wages of any laborer or mechanic include the amount of any costs reasonably anticipated in providing benefits under a plan or program described in section 1(b)(2)(B) of the Davis-Bacon Act, the contractor shall maintain records which show that the commitment to provide such benefits is enforceable, that the plan or program is financially responsible, and that the plan or program has been communicated in writing to the laborers or mechanics affected, and records which show the costs anticipated or the actual cost incurred in providing such benefits. Contractors employing apprentices or trainees under approved programs shall maintain written evidence of the registration of apprenticeship programs and certification of trainee programs, the registration of the apprentices and trainees, and the ratios and wage rates prescribed in the applicable programs.

(ii)(A) The contractor shall submit weekly, for each week in which any contract work is performed, a copy of all payrolls to the subrecipient, that is, the entity that receives the sub-grant or loan from the State capitalization grant recipient. Such documentation shall be available on request of the State recipient or EPA. As to each payroll copy received, the subrecipient shall provide written confirmation in a form satisfactory to the State indicating whether or not the project is in compliance with the requirements of 29 CFR 5.5(a)(1) based on the most recent payroll copies for the specified week. The payrolls shall set out accurately and completely all of the information required to be maintained under 29 CFR 5.5(a)(3)(i), except that full social security numbers and home addresses shall not be included on the weekly payrolls. Instead the payrolls shall only need to include an individually identifying number for each employee (e.g., the last four digits of the employee's social security number). The required weekly payroll information may be submitted in any form desired. Optional Form WH-347 is available for this purpose from the Wage and Hour Division Web site at <http://www.dol.gov/whd/forms/wh347instr.htm> or its successor site. The prime contractor is responsible for the submission of copies of payrolls by all subcontractors. Contractors and subcontractors shall maintain the full social security number and current address of each covered worker, and shall provide them upon request to the subrecipient(s) for transmission to the State or EPA if requested by EPA, the State, the contractor, or the Wage and Hour Division of the Department of Labor for purposes of an investigation or audit of compliance with prevailing wage requirements. It is not a violation of this section for a prime contractor to require a subcontractor to provide addresses and social security numbers to the prime contractor for its own records, without weekly submission to the subrecipient(s).

(B) Each payroll submitted shall be accompanied by a "Statement of Compliance," signed by the contractor or subcontractor or his or her agent who pays or supervises the payment of the persons employed under the contract and shall certify the following:

(1) That the payroll for the payroll period contains the information required to be provided under § 5.5 (a)(3)(ii) of Regulations, 29 CFR part 5, the appropriate information is being maintained under § 5.5 (a)(3)(i) of Regulations, 29 CFR part 5, and that such information is correct and complete;

(2) That each laborer or mechanic (including each helper, apprentice, and trainee) employed on the contract during the payroll period has been paid the full weekly wages earned, without rebate, either directly or indirectly, and that no deductions have been made either directly or indirectly from the full wages earned, other than permissible deductions as set forth in Regulations, 29 CFR part 3;

(3) That each laborer or mechanic has been paid not less than the applicable wage rates and fringe benefits or cash equivalents for the classification of work performed, as specified in the applicable wage determination incorporated into the contract.

(C) The weekly submission of a properly executed certification set forth on the reverse side of Optional Form WH-347 shall satisfy the requirement for submission of the "Statement of Compliance" required by paragraph (a)(3)(ii)(B) of this section.

(D) The falsification of any of the above certifications may subject the contractor or subcontractor to civil or criminal prosecution under section 1001 of title 18 and section 231 of title 31 of the United States Code.

(iii) The contractor or subcontractor shall make the records required under paragraph (a)(3)(i) of this section available for inspection, copying, or transcription by authorized representatives of the State, EPA or the Department of Labor, and shall permit such representatives to interview employees during working hours on the job. If the contractor or subcontractor fails to submit the required records or to make them available, the Federal agency or State may, after written notice to the contractor, sponsor, applicant, or owner, take such action as may be necessary to cause the suspension of any further payment, advance, or guarantee of funds. Furthermore, failure to submit the required records upon request or to make such records available may be grounds for debarment action pursuant to 29 CFR 5.12.

(4) Apprentices and trainees.

(i) Apprentices. Apprentices will be permitted to work at less than the predetermined rate for the work they performed when they are employed pursuant to and individually registered in a bona fide apprenticeship program registered with the U.S. Department of Labor, Employment and Training Administration, Office of Apprenticeship Training, Employer and Labor Services, or with a State Apprenticeship Agency recognized by the Office, or if a person is employed in his or her first 90 days of probationary employment as an apprentice in such an apprenticeship program, who is not individually registered in the program, but who has been certified by the Office of Apprenticeship Training, Employer and Labor Services or a State Apprenticeship Agency (where appropriate) to be eligible for probationary employment as an apprentice. The allowable ratio of apprentices to journeymen on the job site in any craft classification shall not be greater than the ratio permitted to the contractor as to the entire work force under the registered

program. Any worker listed on a payroll at an apprentice wage rate, who is not registered or otherwise employed as stated above, shall be paid not less than the applicable wage rate on the wage determination for the classification of work actually performed. In addition, any apprentice performing work on the job site in excess of the ratio permitted under the registered program shall be paid not less than the applicable wage rate on the wage determination for the work actually performed. Where a contractor is performing construction on a project in a locality other than that in which its program is registered, the ratios and wage rates (expressed in percentages of the journeyman's hourly rate) specified in the contractor's or subcontractor's registered program shall be observed. Every apprentice must be paid at not less than the rate specified in the registered program for the apprentice's level of progress, expressed as a percentage of the journeymen hourly rate specified in the applicable wage determination. Apprentices shall be paid fringe benefits in accordance with the provisions of the apprenticeship program. If the apprenticeship program does not specify fringe benefits, apprentices must be paid the full amount of fringe benefits listed on the wage determination for the applicable classification. If the Administrator determines that a different practice prevails for the applicable apprentice classification, fringes shall be paid in accordance with that determination. In the event the Office of Apprenticeship Training, Employer and Labor Services, or a State Apprenticeship Agency recognized by the Office, withdraws approval of an apprenticeship program, the contractor will no longer be permitted to utilize apprentices at less than the applicable predetermined rate for the work performed until an acceptable program is approved.

(ii) Trainees. Except as provided in 29 CFR 5.16, trainees will not be permitted to work at less than the predetermined rate for the work performed unless they are employed pursuant to and individually registered in a program which has received prior approval, evidenced by formal certification by the U.S. Department of Labor, Employment and Training Administration. The ratio of trainees to journeymen on the job site shall not be greater than permitted under the plan approved by the Employment and Training Administration. Every trainee must be paid at not less than the rate specified in the approved program for the trainee's level of progress, expressed as a percentage of the journeyman hourly rate specified in the applicable wage determination. Trainees shall be paid fringe benefits in accordance with the provisions of the trainee program. If the trainee program does not mention fringe benefits, trainees shall be paid the full amount of fringe benefits listed on the wage determination unless the Administrator of the Wage and Hour Division determines that there is an apprenticeship program associated with the corresponding journeyman wage rate on the wage determination which provides for less than full fringe benefits for apprentices. Any employee listed on the payroll at a trainee rate who is not registered and participating in a training plan approved by the Employment and Training Administration shall be paid not less than the applicable wage rate on the wage determination for the classification of work actually performed. In addition, any trainee performing work on the job site in excess of the ratio permitted under the registered program shall be paid not less than the applicable wage rate on the wage determination for the work actually performed. In the event the Employment and Training Administration withdraws approval of a training program, the contractor will no longer be permitted to utilize trainees at less than the applicable predetermined rate for the work performed until an acceptable program is approved.

(iii) Equal employment opportunity. The utilization of apprentices, trainees and journeymen under this part shall be in conformity with the equal employment opportunity requirements of Executive Order 11246, as amended, and 29 CFR part 30.

(5) Compliance with Copeland Act requirements. The contractor shall comply with the requirements of 29 CFR part 3, which are incorporated by reference in this contract.

(6) Subcontracts. The contractor or subcontractor shall insert in any subcontracts the clauses contained in 29 CFR 5.5(a)(1) through (10) and such other clauses as the EPA determines may be appropriate, and also a clause requiring the subcontractors to include these clauses in any lower tier subcontracts. The prime contractor shall be responsible for the compliance by any subcontractor or lower tier subcontractor with all the contract clauses in 29 CFR 5.5.

(7) Contract termination: debarment. A breach of the contract clauses in 29 CFR 5.5 may be grounds for termination of the contract, and for debarment as a contractor and a subcontractor as provided in 29 CFR 5.12.

(8) Compliance with Davis-Bacon and Related Act requirements. All rulings and interpretations of the Davis-Bacon and Related Acts contained in 29 CFR parts 1, 3, and 5 are herein incorporated by reference in this contract.

(9) Disputes concerning labor standards. Disputes arising out of the labor standards provisions of this contract shall not be subject to the general disputes clause of this contract. Such disputes shall be resolved in accordance with the procedures of the Department of Labor set forth in 29 CFR parts 5, 6, and 7. Disputes within the meaning of this clause include disputes between the contractor (or any of its subcontractors) and Subrecipient(s), State, EPA, the U.S. Department of Labor, or the employees or their representatives.

(10) Certification of eligibility.

(i) By entering into this contract, the contractor certifies that neither it (nor he or she) nor any person or firm who has an interest in the contractor's firm is a person or firm ineligible to be awarded Government contracts by virtue of section 3(a) of the Davis-Bacon Act or 29 CFR 5.12(a)(1).

(ii) No part of this contract shall be subcontracted to any person or firm ineligible for award of a Government contract by virtue of section 3(a) of the Davis-Bacon Act or 29 CFR 5.12(a)(1).

(iii) The penalty for making false statements is prescribed in the U.S. Criminal Code, 18 U.S.C. 1001.

4. Contract Provision for Contracts in Excess of \$100,000.

(a) Contract Work Hours and Safety Standards Act. The subrecipient shall insert the following clauses set forth in paragraphs (a)(1), (2), (3), and (4) of this section in full in any contract in an amount in excess of \$100,000 and subject to the overtime provisions of the Contract Work Hours and Safety Standards Act. These clauses shall be inserted in addition to the clauses required by Item 3, above or 29 CFR 4.6. As used in this paragraph, the terms laborers and mechanics include watchmen and guards.

(1) Overtime requirements. No contractor or subcontractor contracting for any part of the contract work which may require or involve the employment of laborers or mechanics shall require or permit any such laborer or mechanic in any workweek in which he or she is employed on such work to work in excess of forty hours in such workweek unless such laborer or mechanic receives compensation at a rate not less than one and one-half times the basic rate of pay for all hours worked in excess of forty hours in such workweek.

(2) Violation; liability for unpaid wages; liquidated damages. In the event of any violation of the clause set forth in paragraph (b)(1) of this section the contractor and any subcontractor responsible therefore shall be liable for the unpaid wages. In addition, such contractor and subcontractor shall be liable to the United States (in the case of work done under contract for the District of Columbia or a territory, to such District or to such territory), for liquidated damages. Such liquidated damages shall be computed with respect to each individual laborer or mechanic, including watchmen and guards, employed in violation of the clause set forth in paragraph (b)(1) of this section, in the sum of \$10 for each calendar day on which such individual was required or permitted to work in excess of the standard workweek of forty hours without payment of the overtime wages required by the clause set forth in paragraph (b)(1) of this section.

(3) Withholding for unpaid wages and liquidated damages. The subrecipient shall upon the request of the EPA Award Official or an authorized representative of the Department of Labor, withhold or cause to be withheld, from any moneys payable on account of work performed by the contractor or subcontractor under any such contract or any other Federal contract with the same prime contractor, or any other federally-assisted contract subject to the Contract Work Hours and Safety Standards Act, which is held by the same prime contractor, such sums as may be determined to be necessary to satisfy any liabilities of such contractor or subcontractor for unpaid wages and liquidated damages as provided in the clause set forth in paragraph (a)(2) of this section.

(4) Subcontracts. The contractor or subcontractor shall insert in any subcontracts the clauses set forth in paragraph (b)(1) through (4) of this section and also a clause requiring the subcontractors to include these clauses in any lower tier subcontracts. The prime contractor shall be responsible for compliance by any subcontractor or lower tier subcontractor with the clauses set forth in paragraphs (b)(1) through (4) of this section.

(c) In addition to the clauses contained in Item 3, above, in any contract subject only to the Contract Work Hours and Safety Standards Act and not to any of the other statutes cited in 29 CFR 5.1, the Subrecipient shall insert a clause requiring that the contractor or subcontractor shall maintain payrolls and basic payroll records during the course of the work and shall preserve them for a period of three years from the completion of the contract for all laborers and mechanics, including guards and watchmen, working on the contract. Such records shall contain the name and address of each such employee, social security number, correct classifications, hourly rates of wages paid, daily and weekly number of hours worked, deductions made, and actual wages paid. Further, the Subrecipient shall insert in any such contract a clause providing that the records to be maintained under this paragraph shall be made available by the contractor or subcontractor for inspection, copying, or transcription by authorized representatives of the (write the name of agency) and the Department of Labor, and the contractor or subcontractor will permit such representatives to interview employees during working hours on the job.

5. Compliance Verification.

(a) The subrecipient shall periodically interview a sufficient number of employees entitled to DB prevailing wages (covered employees) to verify that contractors or subcontractors are paying the appropriate wage rates. As provided in 29 CFR 5.6(a)(6), all interviews must be conducted in confidence. The subrecipient must use Standard Form 1445 (SF 1445) or equivalent documentation to memorialize the interviews. Copies of the SF 1445 are available from EPA on request.

(b) The subrecipient shall establish and follow an interview schedule based on its assessment of the risks of noncompliance with DB posed by contractors or subcontractors and the duration of the contract or subcontract. Subrecipients must conduct more frequent interviews if the initial interviews or other information indicates that there is a risk that the contractor or subcontractor is not complying with DB. Subrecipients shall immediately conduct necessary interviews in response to an alleged violation of the prevailing wage requirements. All interviews shall be conducted in confidence.

(c) The subrecipient shall periodically conduct spot checks of a representative sample of weekly payroll data to verify that contractors or subcontractors are paying the appropriate wage rates. The subrecipient shall establish and follow a spot check schedule based on its assessment of the risks of noncompliance with DB posed by contractors or subcontractors and the duration of the contract or subcontract. At a minimum, if practicable the subrecipient should spot check payroll data within two weeks of each contractor or subcontractor's submission of its initial payroll data and two weeks prior to the completion date the contract or subcontract. Subrecipients must conduct more frequent spot checks if the initial spot check or other information indicates that there is a risk that the contractor or subcontractor is not complying with DB . In addition, during the examinations the subrecipient shall verify evidence of fringe benefit plans and payments thereunder by contractors and subcontractors who claim credit for fringe benefit contributions.

(d) The subrecipient shall periodically review contractors and subcontractors use of apprentices and trainees to verify registration and certification with respect to apprenticeship and training programs approved by either the U.S Department of Labor or a state, as appropriate, and that contractors and subcontractors are not using disproportionate numbers of, laborers, trainees and apprentices. These reviews shall be conducted in accordance with the schedules for spot checks and interviews described in Item 5(b) and (c) above.

(e) Subrecipients must immediately report potential violations of the DB prevailing wage requirements to the EPA DB contact listed above and to the appropriate DOL Wage and Hour District Office listed at <http://www.dol.gov/whd/america2.htm> or its successor site.

Attachment Number 15

American Iron and Steel Requirement

The Contractor acknowledges to and for the benefit of the _____ (“Purchaser”) and the State of Kentucky (the “State”) that it understands the goods and services under this Agreement are being funded with monies made available by the Clean Water State Revolving Fund and/or Drinking Water State Revolving Fund that have statutory requirements commonly known as “American Iron and Steel;” that requires all of the iron and steel products used in the project to be produced in the United States (“American Iron and Steel Requirement”) including iron and steel products provided by the Contractor pursuant to this Agreement.

The Contractor hereby represents and warrants to and for the benefit of the Purchaser and the State that (a) the Contractor has reviewed and understands the American Iron and Steel Requirement, (b) all of the iron and steel products used in the project will be and/or have been produced in the United States in a manner that complies with the American Iron and Steel Requirement, unless a waiver of the requirement is approved, and (c) the Contractor will provide any further verified information, certification or assurance of compliance with this paragraph, or information necessary to support a waiver of the American Iron and Steel Requirement, as may be requested by the Purchaser or the State. Notwithstanding any other provision of this Agreement, any failure to comply with this paragraph by the Contractor shall permit the Purchaser or State to recover as damages against the Contractor any loss, expense, or cost (including without limitation attorney’s fees) incurred by the Purchaser or State resulting from any such failure (including without limitation any impairment or loss of funding, whether in whole or in part, from the State or any damages owed to the State by the Purchaser).

While the Contractor has no direct contractual privity with the State, as a lender to the Purchaser for the funding of its project, the Purchaser and the Contractor agree that the State is a third-party beneficiary and neither this paragraph (nor any other provision of this Agreement necessary to give this paragraph force or effect) shall be amended or waived without the prior written consent of the State.

Sample Certification

The following information is provided as a sample letter of step certification for AIS compliance. Documentation must be provided on company letterhead.

Date

Company Name

Company Address

City, State Zip

Subject: American Iron and Steel Step Certification for Project (XXXXXXXXXXXX)

I, (company representative), certify that the (melting, bending, coating, galvanizing, cutting, etc.) process for (manufacturing or fabricating) the following products and/or materials shipped or provided for the subject project is in full compliance with the American Iron and Steel requirement as mandated in EPA's State Revolving Fund Programs.

Item, Products and/or Materials:

1. XXXX
2. XXXX
3. XXXX

Such process took place at the following location:

If any of the above compliance statements change while providing material to this project we will immediately notify the prime contractor and the engineer.

Signed by company representative

ADDENDUM NO. 3
WATER SYSTEM IMPROVEMENTS
CONTRACT 15-01
16-INCH NORTH WATER TRANSMISSION LINE – PHASE I
OHIO COUNTY WATER DISTRICT
OHIO COUNTY, KENTUCKY
JRWCO JOB NO. 2021

Date of Addendum: Friday, March 25, 2016

Bid Opening: Tuesday, March 29, 2016, 4:30 p.m. Local Time

1. Detailed Specifications, Section 4. Water Line and Appurtenances, Paragraph 3. Pipeline Materials for Water Lines, Subparagraph c. Polyvinyl Chloride (PVC) Pressure Pipe, Page DS 4-4:

Modify item (1) of this subparagraph as follows:

“(1) Materials, Manufacturer and Joints

Polyvinyl Chloride (PVC) Pressure Pipe shall conform to ANSI/AWWA Standard C-905 and shall be installed in accordance with ANSI/AWWA C-605 as amended or extended in these Specifications. The pipe shall be CI outside diameter in accordance with Table 2 of ANSI/AWWA C-905. PVC pipe shall be **blue** in color.

The following classes of pipe and pressure ratings are called for:

<u>Outside Diameter (in.)</u>	<u>Dimension Ration (DR)</u>	<u>Min. Wall Thickness</u>	<u>Pressure Class (psi)</u>
17.40	21	0.829	200”

J. R. WAUFORD & COMPANY,
CONSULTING ENGINEERS, INC.

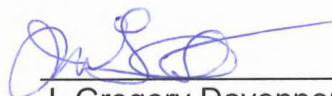

 J. Gregory Davenport, P.E.
 Kentucky License No. 22752

3305APE20150001
092.0332-15-001

PROJECT MANUAL

SPECIFICATIONS AND CONTRACT DOCUMENTS

WATER SYSTEM IMPROVEMENTS

FOR

**OHIO COUNTY WATER DISTRICT
OHIO COUNTY, KENTUCKY**

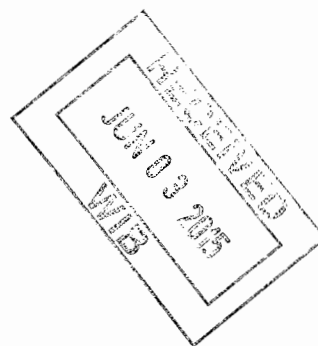

**CONTRACT 15-01
16-INCH NORTH WATER TRANSMISSION LINE – PHASE I**

**Funded in part by Kentucky Infrastructure Authority Federally
Assisted Drinking Water Revolving Loan Fund #F15-069**

JOB NUMBER 2021

JUNE 2015

**J. R. WAUFORD & COMPANY
CONSULTING ENGINEERS, INC.
2835 Lebanon Road
Nashville, Tennessee 37214
www.jrwauford.com**

ADDENDUM NO. 2
WATER SYSTEM IMPROVEMENTS
CONTRACT 15-01
16-INCH NORTH WATER TRANSMISSION LINE – PHASE I
OHIO COUNTY WATER DISTRICT
OHIO COUNTY, KENTUCKY
JRWCO JOB NO. 2021

Date of Addendum: Thursday, March 10, 2016

Bid Opening: Tuesday, March 29, 2016, 4:30 p.m. Local Time

1. Advertisement for Bids, Page AB-1:

Modify the first two paragraphs on this page to read as follows:

“Separate sealed BIDS for the construction of Water System Improvements for the Ohio County Water District will be received at 124 East Washington Street, Hartford, Kentucky 42437 until 4:00 p.m. Local Time, **Tuesday, March 29**, 2016, and then will be publicly opened and read aloud at **4:30** p.m. Bids being mailed should be sent to Walt Beasley, General Manager, Ohio County Water District, Administrative Offices, P.O. Box 207, Hartford, Kentucky 42347, and the bidder shall be responsible for timely delivery.

The work involved is in one (1) contract and consists of the following generally described work:

CONTRACT 15-01
16-INCH NORTH WATER TRANSMISSION LINE – PHASE I

- Three Lump Sum connections to existing 8-inch (1), 10-inch (1), and 12-inch (1) Water Lines
- **265** L.F. of 24-inch Steel Casing Pipe bored under Western Kentucky Parkway
- **275** L.F. of 16-inch RJDIP installed in 24-inch Steel Casing Pipe
- 3,450 L.F. of 16-inch Class 250 DIP
- **12,151** L.F. of 16-inch C-905 PVC
- 3 Each Fire Hydrant Assemblies
- 6 Each 16-inch Butterfly Valve Assemblies
- 11 Each 4-inch Air Release Valve Assemblies
- BCBC Tank Control Valve and Structure”

2. Detailed Specifications, Section 1. General Scope and Special Provisions, Paragraph 1. Scope of Work, Page DS 1-1:

Modify this paragraph as follows:

“1. Scope of Work

The work to be accomplished under these Detailed Specifications consists of furnishing all labor, materials, equipment and services necessary for the construction of Water System Improvements, Contract 15-01 – 16-inch North Water Transmission Line – Phase I for the Ohio County Water District. The work involved is in one (1) contract and consists of the following generally described work:

CONTRACT 15-01
16-INCH NORTH WATER TRANSMISSION LINE – PHASE I

- Three Lump Sum connections to existing 8-inch (1), 10-inch (1), and 12-inch (1) Water Lines
- **265** L.F. of 24-inch Steel Casing Pipe bored under Western Kentucky Parkway
- **275** L.F. of 16-inch RJDIP installed in 24-inch Steel Casing Pipe
- 3,450 L.F. of 16-inch Class 250 DIP
- **12,151** L.F. of 16-inch C-905 PVC
- 3 Each Fire Hydrant Assemblies
- 6 Each 16-inch Butterfly Valve Assemblies
- 11 Each 4-inch Air Release Valve Assemblies
- BCBC Tank Control Valve and Structure”

3. Detailed Specifications, Section 4. Water Line and Appurtenances, Paragraph 1. Scope of Work, Page DS 4-1:

Modify this paragraph as follows:

“1. Scope of Work

The work covered under this section of these Detailed Specifications consists of furnishing all labor, materials, equipment and services necessary for the construction of Water System Improvements, Contract 15-01 – 16-inch North Water Transmission Line – Phase I as generally outlined hereinafter and as specifically described in these Detailed Specifications. The work will be delivered under one contract with the approximate quantities and descriptions as follows:

CONTRACT 15-01
16-INCH NORTH WATER TRANSMISSION LINE – PHASE I

- Three Lump Sum connections to existing 8-inch (1), 10-inch (1), and 12-inch (1) Water Lines
 - **265** L.F. of 24-inch Steel Casing Pipe bored under Western Kentucky Parkway
 - **275** L.F. of 16-inch RJDIP installed in 24-inch Steel Casing Pipe
 - 3,450 L.F. of 16-inch Class 250 DIP
 - **12,151** L.F. of 16-inch C-905 PVC
 - 3 Each Fire Hydrant Assemblies
 - 6 Each 16-inch Butterfly Valve Assemblies
 - 11 Each 4-inch Air Release Valve Assemblies
 - BCBC Tank Control Valve and Structure”
4. Detailed Specifications, Section 4. Water Line and Appurtenances, Paragraph 22. Air Valves and Pits, subparagraph a. General, Page DS 4-18:

Modify this subparagraph as follows:

“a. General

Air Valves in Concrete Pits shall be installed at the high points in the pipelines as shown on the Plans. This item includes the miscellaneous metals, small valves and piping within the pit as shown on the Plans. Air Valves shall be Vent-O-Mat Model No. **100RBX1941E4** suitable for the working pressure and test pressure as shown on the Plans.

All Air Valves shall be double orifice with anti-shock orifice mechanism. The bottom flange shall be ANSI B16.1 Class 125 suitable for mounting to the 4-inch ductile iron piping as shown on the Plans.”

5. BID FORM, Pages BF-5 and BF-6:

Replace with attached Pages BF-5* and BF-6*.

J. R. WAUFORD & COMPANY,
CONSULTING ENGINEERS, INC.



J. Gregory Davenport, P.E.
Kentucky License No. 22752

BID FORM
2021 – June 2015

8. BID FORM A: CONTRACT 15-01
16-INCH NORTH WATER TRANSMISSION LINE – PHASE I (Cont'd)

ITEM NUMBER	APPROXIMATE QUANTITY	DESCRIPTION WITH UNIT BID PRICE WRITTEN IN WORDS	UNIT PRICE	TOTAL PRICE
5.	12,151 L.F.	Furnish and install 16-inch DR 21 C905 PVC Water Line, including fittings, excavation and bedding materials as shown on the Plans and as specified herein, complete in place For _____ _____ Dollars _____ Cents, per linear foot	\$ _____	\$ _____
6.	3,450 L.F.	Install 16-inch Pressure Class 250 D.I.P. Water Line, including fittings, excavation and bedding materials as shown on the Plans and as specified herein, complete in place For _____ _____ Dollars _____ Cents, per linear foot	\$ _____	\$ _____

BID FORM
2021 – June 2015

8. BID FORM A: CONTRACT 15-01
16-INCH NORTH WATER TRANSMISSION LINE – PHASE I (Cont'd)

ITEM NUMBER	APPROXIMATE QUANTITY	DESCRIPTION WITH UNIT BID PRICE WRITTEN IN WORDS	UNIT PRICE	TOTAL PRICE
7.	265 L.F.	24-inch Steel Casing Pipe, 0.500-inch minimum wall thickness bored under Western Kentucky Parkway, including all incidentals except for carrier pipe as shown on the Plans and specified herein, complete in place For _____ _____ Dollars _____ Cents, per linear foot	\$ _____	\$ _____
8.	275 L.F.	16-inch Class 250 R.J.D.I.P. Water Line installed in 24-inch Steel Casing Pipe under Western Kentucky Parkway, including casing spacers, all excavation and bedding as shown on the Plans and specified herein, complete in place For _____ _____ Dollars _____ Cents, per linear foot	\$ _____	\$ _____

PROJECT MANUAL

SPECIFICATIONS AND CONTRACT DOCUMENTS

WATER SYSTEM IMPROVEMENTS

FOR

**OHIO COUNTY WATER DISTRICT
OHIO COUNTY, KENTUCKY**

**CONTRACT 15-01
16-INCH NORTH WATER TRANSMISSION LINE – PHASE I**

**Funded in part by Kentucky Infrastructure Authority Federally
Assisted Drinking Water Revolving Loan Fund #F15-069**

JOB NUMBER 2021

JUNE 2015

**J. R. WAUFORD & COMPANY
CONSULTING ENGINEERS, INC.
2835 Lebanon Road
Nashville, Tennessee 37214
www.jrwauford.com**

PROJECT MANUAL

SPECIFICATIONS AND CONTRACT DOCUMENTS

WATER SYSTEM IMPROVEMENTS

FOR

OHIO COUNTY WATER DISTRICT
OHIO COUNTY, KENTUCKY

CONTRACT 15-01
16-INCH NORTH WATER TRANSMISSION LINE – PHASE I

Funded in part by Kentucky Infrastructure Authority Federally
Assisted Drinking Water Revolving Loan Fund #F15-069

JOB NUMBER 2021

JUNE 2015

J. R. WAUFORD & COMPANY
CONSULTING ENGINEERS, INC.
2835 Lebanon Road
Nashville, Tennessee 37214
www.jrwauford.com

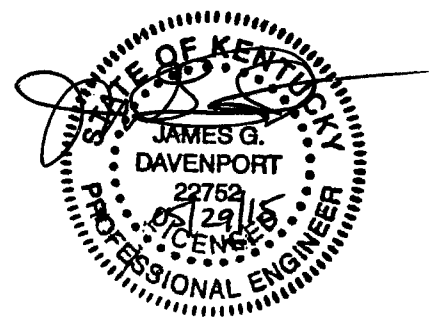

OFFICIALS
FOR THE
OHIO COUNTY WATER DISTRICT

GENERAL MANAGER

Walt Beasley

BOARD MEMBERS

Ben Everley, Chairman
James Dewayne Johnson, Secretary
Chuck Price, Treasurer
Mark Whitehouse
Eddie Embry
Cletus Greer
Reid Haire

TABLE OF CONTENTS
2021 – June 2015

TABLE OF CONTENTS

Advertisement for Bids	AB-1 – AB-3
Instructions to Bidders - Kentucky	IB-1 – IB-11
General Conditions	GC-1 – GC-69
Supplementary Conditions – Kentucky – SRF	SC-1 – SC-2
A Listing of the Duties, Responsibilities and Limitation of Authority of the Resident Project Representative	1 – 4
Supplemental General Conditions for Clean Water State Revolving Fund, Drinking Water State Revolving Fund	1 – 52
Davis-Bacon Wage Rate	
Kentucky Department of Labor Prevailing Wage Rate	

DETAILED SPECIFICATIONS

SECTION 1 – General Scope and Special Provisions

1. Scope of Work	DS 1-1
2. Execution and Coordination of the Work	DS 1-1
3. Temporary Traffic Control Plan	DS 1-2
4. Time of Completion and Liquidated Damages	DS 1-2
5. Guarantee	DS 1-2
6. Progress Schedule and Progress Meetings	DS 1-3
7. Initial Video Tapes and Progress Pictures	DS 1-3
8. Lines and Grades	DS 1-3
9. Lands, Rights-of-Way and Limits of Work	DS 1-4
10. Restoration of Disturbed Areas in Connection with Work on or Adjacent to Private Property	DS 1-5
11. Existing Utilities	DS 1-5
12. Substantial Completion/Delays in Final Completion	DS 1-6
13. Reference to Kentucky Transportation Cabinet, Department of Highways Standard Specifications for Road and Bridge Construction	DS 1-6
14. Undesirable Workmen	DS 1-7
15. Protection of Roadways On and Off-Site	DS 1-7
16. Shop Drawings	DS 1-7
17. Materials or Equipment to be Furnished	DS 1-8
18. Permits, Codes, Agreements and/or Contracts with Private Utilities	DS 1-9
19. Utilities Required by Contractor	DS 1-9
20. Blasting	DS 1-9
21. Subsurface Conditions/Site Conditions	DS 1-9
22. Connecting to Existing Lines	DS 1-9
23. Water and Uplift	DS 1-9
24. Occupational Safety and Health Act	DS 1-9

TABLE OF CONTENTS
2021 – June 2015

25.	Chemical Requirements.....	DS 1-10
26.	Disposal of Demolition Debris.....	DS 1-10
27.	Engineer's Authority.....	DS 1-10
28.	Confined Spaces.....	DS 1-10
29.	Field Office.....	DS 1-10
30.	Applicability of Government Standards.....	DS 1-11
31.	Project Sign.....	DS 1-11
32.	Flooding.....	DS 1-11
33.	Noise, Odor and Dust Control.....	DS 1-11
34.	Work Hours.....	DS 1-11
35.	Final Clean-Up.....	DS 1-11
36.	Utility Line Crossings of State Highways.....	DS 1-11
37.	Temporary Project Water Pollution Control (Soil Erosion).....	DS 1-12
	Storm Water Pollution Prevention Plan	
	NOI – SWCA	
	NOT – SWCA	

SECTION 2 – Testing and Control of Materials

1.	Scope.....	DS 2-1
2.	Cost of Tests and Selection of Testing Agencies.....	DS 2-1
3.	Sources of Supply.....	DS 2-1
4.	Approval of Testing Agencies and Reports.....	DS 2-2
5.	Governing Specifications.....	DS 2-2
6.	Extent of Inspection and Testing Service.....	DS 2-2
7.	Cement.....	DS 2-3
8.	Fine Aggregate (For Use in Cement Concrete).....	DS 2-3
9.	Coarse Aggregate (For Use in Cement Concrete).....	DS 2-3
10.	Advance Tests of Concrete Design Mix(es).....	DS 2-3
11.	Reinforcing Steel.....	DS 2-4
12.	Structural Steel.....	DS 2-4
13.	Steel Bar Joists.....	DS 2-4
14.	Brick.....	DS 2-5
15.	Building Stone.....	DS 2-5
16.	Vitrified Clay Sewer Pipe.....	DS 2-5
17.	Concrete Pipe.....	DS 2-6
18.	Polyvinyl Chloride (PVC) Pressure Pipe.....	DS 2-6
19.	Polyvinyl Chloride (PVC) Sewer Pipe.....	DS 2-7
20.	Acrylonitrile – Butadiene – Styrene (ABS) Composite Sewer Pipe.....	DS 2-7
21.	Cast Iron and Ductile Iron Pipe and Special Castings.....	DS 2-8
22.	Grey Iron Castings.....	DS 2-8
23.	Steel Gas Pipe.....	DS 2-8
24.	Polyethylene Pipe.....	DS 2-9

TABLE OF CONTENTS
2021 – June 2015

SECTION 3 – Concrete and Reinforcing Steel

1.	Scope.....	DS 3-1
2.	Reference Codes and Standards.....	DS 3-1
3.	Class of Concrete.....	DS 3-2
4.	Determination of Strength of Concrete.....	DS 3-3
5.	Concrete Design Mixes.....	DS 3-3
6.	Materials for Concrete.....	DS 3-3
7.	Proportioning of Materials for Concrete.....	DS 3-5
8.	Source of Supply of Concrete.....	DS 3-6
9.	Alteration of Concrete Slump (Retempering).....	DS 3-8
10.	Placing of Concrete.....	DS 3-8
11.	Curing of Concrete.....	DS 3-11
12.	Joints in Concrete.....	DS 3-12
13.	Non-Shrink Grout.....	DS 3-15
14.	Forms for Concrete Work.....	DS 3-15
15.	Floor Drains, Sleeves and Inserts.....	DS 3-18
16.	Slabs on Grade.....	DS 3-18
17.	Aluminum Safety Treads.....	DS 3-21
18.	Concrete Finish.....	DS 3-21
19.	Watertightness.....	DS 3-23
20.	Defective Concrete.....	DS 3-24
21.	Testing of Concrete.....	DS 3-25
22.	Reinforcing Steel.....	DS 3-26
23.	Concrete Repair Material.....	DS 3-27

SECTION 4 – Water Line and Appurtenances

1.	Scope of Work.....	DS 4-1
2.	Location of Lines.....	DS 4-1
3.	Pipeline Material for Water Lines.....	DS 4-2
4.	On-Site Inspection of Pipeline Materials.....	DS 4-5
5.	Lines and Grades.....	DS 4-6
6.	Excavation for Pipeline Trenches and Appurtenances.....	DS 4-6
7.	Rock Excavation.....	DS 4-9
8.	Pipe Laying and Bedding for Water Lines.....	DS 4-9
9.	Unauthorized Excavation and Over-Breakage.....	DS 4-10
10.	Crushed Stone for Pipe Bedding in Rock.....	DS 4-11
11.	Backfilling Pipeline Trenches.....	DS 4-11
12.	Pipeline Trenches Within Existing Roadways.....	DS 4-13
13.	Inspection of Lines – During Construction.....	DS 4-13
14.	Testing of Water Lines.....	DS 4-13
15.	Connections/Disconnections.....	DS 4-14
16.	Fire Hydrants.....	DS 4-14
17.	Disinfection of Water Lines.....	DS 4-15

TABLE OF CONTENTS
2021 – June 2015

18.	Pipeline Crossings of Roadways	DS 4-15
19.	Gate Valves and Boxes	DS 4-16
20.	Tapping Sleeves and Valves	DS 4-17
21.	Butterfly Valves and Boxes	DS 4-17
22.	Air Valves and Pits	DS 4-18
23.	Replacing Streets and Roadways	DS 4-19
24.	Class "C" Concrete for Kickers, Anchors and Encasements	DS 4-21
25.	Removing and Replacing Concrete Driveways and Paved Ditches	DS 4-21
26.	Removing and Replacing Sidewalks, Curbs and Gutters	DS 4-21
27.	Finish Grading, Topsoiling, Seeding and Sodding	DS 4-22
28.	Final Clean-up	DS 4-22
29.	Temporary Project Water Pollution Control (Soil Erosion)	DS 4-23
30.	BCBC Tank Control Valve and Structure	DS 4-23
	Kentucky Transportation Cabinet Surface Restoration Methods	

SECTION 5 – Basis of Payment

1.	General	DS 5-1
2.	Water Lines	DS 5-1
3.	Steel Casing Pipe Under Western Kentucky Parkway	DS 5-1
4.	Restrained Joint Pipe Installed Steel Casing Under Western Kentucky Parkway	DS 5-1
5.	Butterfly Valves and Boxes	DS 5-2
6.	Tapping Sleeve and Valve	DS 5-2
7.	Air Release Valves and Boxes	DS 5-2
8.	Connections to Existing Water Lines	DS 5-2
9.	Fire Hydrants	DS 5-2
10.	Undercutting Where Directed by Engineer	DS 5-2
11.	KYTC No. 57 Crushed Stone for Ditch Backfill Under Paved Surfaces Where Required by the Engineer	DS 5-3
12.	Dense Grade Aggregate Crushed Stone for Traffic Bound Surfacing, Base Course and/or Backfill Where Required by the Engineer	DS 5-3
13.	Flowable Fill for Backfill Where Required by the Engineer	DS 5-3
14.	Class "C" Concrete for Cradles, Anchors and Encasements	DS 5-4
15.	Asphaltic Concrete Pavement	DS 5-4
16.	Temporary Silt Fence	DS 5-4
17.	Steel Marker Posts	DS 5-4
18.	BCBC Tank Control Valve and Structure	DS 5-4
	Bid Form	BF-1 – BF-12
	Required Affidavit for Bidders, Offerors and Contractors Claiming Resident Bidder Status	
	Required Affidavit for Bidders, Offerors and Contractors Claiming Qualified Bidder Status	
	Bid Bond	BB-1 – BB-3

TABLE OF CONTENTS
2021 – June 2015

Agreement.....	A-1 – A-8
Performance Bond.....	PEB-1 – PEB-2
Payment Bond.....	PAB-1 – PAB-2

ADVERTISEMENT FOR BIDS
2021 – June 2015

ADVERTISEMENT FOR BIDS
WATER SYSTEM IMPROVEMENTS
OHIO COUNTY WATER DISTRICT
OHIO COUNTY, KENTUCKY

Separate sealed BIDS for the construction of Water System Improvements for the Ohio County Water District will be received at 124 East Washington Street, Hartford, Kentucky 42437 until _____, and then at said time and place will be publicly opened and read aloud. Bids being mailed should be sent to Walt Beasley, General Manager, Ohio County Water District, Administrative Offices, P.O. Box 207, Hartford, Kentucky 42347, and the bidder shall be responsible for timely delivery.

The work involved is in one (1) contract and consists of the following generally described work:

CONTRACT 15-01
16-INCH NORTH WATER TRANSMISSION LINE – PHASE I

- Three Lump Sum connections to existing 8-inch (1), 10-inch (1), and 12-inch (1) Water Lines
- 185 L.F. of 24-inch Steel Casing Pipe bored under Western Kentucky Parkway
- 195 L.F. of 16-inch RJDIP installed in 24-inch Steel Casing Pipe
- 3,450 L.F. of 16-inch Class 250 DIP
- 12,226 L.F. of 16-inch C-905 PVC
- 3 Each Fire Hydrant Assemblies
- 6 Each 16-inch Butterfly Valve Assemblies
- 11 Each 4-inch Air Release Valve Assemblies
- BCBC Tank Control Valve and Structure

The allotted time for construction of Contract 15-01 is 270 calendar days; liquidated damages for non-completion are \$1,000 per calendar day.

The CONTRACT DOCUMENTS may be examined at the following locations:

Ohio County Water District, 124 East Washington Street, Hartford, Kentucky 42437

Community Development Office, Kentucky Cabinet for Economic Development, 300 West Broadway, Frankfort, KY 40601

Office of Civil Rights & Small Business Development, Department of Transportation, 200 Mero Street, Frankfort, KY 40622

ADVERTISEMENT FOR BIDS
2021 – June 2015

Minority Economic Development Initiative, Hopkinsville-Christian County Economic Development Council, 2800 Fort Campbell Blvd, Hopkinsville, KY 42240

J. R. Wauford & Company, Consulting Engineers, Inc., 2835 Lebanon Road, Nashville, TN 37214

Builders Exchange of Kentucky, Inc., 2300 Meadow Drive, Louisville, KY 40218

Builders Exchange of Tennessee, 2322 Winford Ave., Nashville, TN 37211

DODGE Data & Analytics for scanning to their website at www.construction.com

Nashville Contractors Association, 7430 Burleson Lane, Murfreesboro, TN 37129

AGC of Western KY, 2201 McCracken Blvd., Paducah, KY 42001

CMD, 30 Technology Parkway South, Suite 100, Norcross, GA 30092

Construction Data, 14205 N. Mo Pac Expy, Suite 550, Austin TX 78728

Copies of the Detailed Specifications, Bid Documents and Contract Documents may be obtained at the office of J. R. Wauford & Company, Consulting Engineers, Inc. located at 2835 Lebanon Road, P. O. Box 140350, Nashville, Tennessee 37214 upon a non-refundable payment of \$250.00 for each set. Inquiries should be directed Scott B. Carroll, P.E., Project Manager, email scottc@jrwauford.com.

The successful bidder or bidders shall be required to furnish both an acceptable performance bond and payment bond each in the amount of one hundred percent (100%) of the contract price.

The Owner reserves the right to reject any and all bids, to waive informalities, and to negotiate with the apparent qualified best bidder or bidders to such extent as may be necessary.

No bidder may withdraw his bid for 90 days, while the Owner considers the bids. Mutually agreed upon time extensions may be made if necessary.

Any contract(s) awarded under this Invitation for Bids are expected to be funded in part by a loan from the Kentucky Infrastructure Authority and/or by a grant from the U.S. Environmental Protection Agency. Neither the United States nor any of its departments, agencies or employees is or will be a party to this Invitation for Bids or any resulting contract. This procurement will be subject to regulations contained in 40 CFR Part 31.36 or with DOW Procurement Guidance with the exception of the Davis-Bacon Act.

ADVERTISEMENT FOR BIDS
2021 – June 2015

ALL BIDDERS must comply with Title VI of the Civil Rights Act of 1964, the Anti-Kickback Act, and the Contract Work Hours Standard Act and 40 CFR 31.36 L (3, 4 & 6).

ALL BIDDERS must comply with the President's Executive Order No. 11246 as amended, which prohibits discrimination in employment regarding race, creed, color, sex or national origin.

ALL BIDDERS, Contractor/Subcontractor will comply with 41 CFR 60-4, in regard to affirmative action, to insure equal opportunity to females and minorities and will apply the time tables and goal set forth in 41 CFR 60-4 if applicable to the area of the project. ALL BIDDERS, make positive efforts to use small, minority, women-owned and disadvantaged businesses.

This project is being funded in part with KIA FADWSRF loan and the award will be made to the lowest responsive and responsible bidder.

OHIO COUNTY WATER DISTRICT
OHIO COUNTY, KENTUCKY
/s/

Walt Beasley
General Manager

INSTRUCTIONS TO BIDDERS
COMMONWEALTH OF KENTUCKY
January 2015

ALPHABETICAL INDEX OF
INSTRUCTIONS TO BIDDERS
COMMONWEALTH OF KENTUCKY

Award of Contract - Kentucky	IB - 4
Bid Guaranty	IB - 2
Certificate of Insurance	IB - 8
Commencement and Completion of Work	IB - 9
Construction Records and Reports	IB - 9
Contract Surety, Performance and Payment Bonds	IB - 3
Discrepancy - Bid Price	IB - 2
Execution of Contracts	IB - 5
Extra Work	IB - 10
Final Payment	IB - 10
Funds for Partial Payment Estimates	IB - 9
Insurance, Builders Risk	IB - 8
Insurance, Contractor's Coverage and Cancellation Provision	IB - 5
Insurance, Commercial General Liability, Automobile Liability and Excess Liability	IB - 6
Insurance, Workmen's Compensation and Employer's Liability	IB - 7
Interpretation of Contract Documents	IB - 3
Lands and Rights-of-Way	IB - 9
Laws and Regulations	IB - 10
Liquidated Damages for Failure to Enter into Contract	IB - 5
Modification of Bids	IB - 3
Payment of Employees	IB - 10
Preparation and Submission of BID FORM	IB - 1
Qualification of Bidders	IB - 2
Sanitary Facilities	IB - 9
Second Hand and Salvaged Materials	IB - 4
Subcontracts	IB - 10
Supplementary Conditions	IB - 1
Wages and Hours and Non-Discrimination	IB - 11

INSTRUCTIONS TO BIDDERS
COMMONWEALTH OF KENTUCKY
January 2015

INSTRUCTIONS TO BIDDERS
COMMONWEALTH OF KENTUCKY

1. Preparation and Submission of BID FORM

Bidders shall inform themselves fully of all conditions relating to the proposed work. Bids shall be submitted on the separate copy of the BID FORM supplied for that purpose. The BID FORM contained in the Specifications and Contract Documents is for the convenience of the Bidders and is not to be detached from the bound set of documents or filled out or executed unless a separate BID FORM is not furnished to the Bidder.

The BID FORM shall be enclosed in a sealed envelope which shall be clearly labeled with the name of the project, contract number, name, and address of the Bidder, and the date and time of opening (so as to guard against premature opening of any Bid).

BID FORMS that contain any omission, conditions, or limitations, or that show any other irregularity of any kind, may be rejected as informal.

Should the Bidder in preparing his Bid find anything necessary for the construction of the project that is not mentioned in the Specifications or shown on the Plans, or any discrepancy, he shall notify the Engineer so that such items may be included or corrected. Should the Bidder fail to notify the Engineer of such items, it will be assumed that his Bid included everything necessary for the complete construction of an operating facility in the true spirit and intent of the designs shown.

The "Bidder" shall mean all those Contractors submitting BID FORMS. After the acceptance of the BID FORM of the successful Bidder, the said term "Bidder" shall be interchangeable with the term "Contractor" as defined in the General Conditions and all things required of Bidders shall likewise apply to the Contractor.

2. Supplementary Conditions

The Supplementary Conditions contain the special requirements of the Agency which is funding the subject project or clarifications to the General Conditions. If the funding is entirely private or local, the Advertisement for Bids will so state.

The Supplementary Conditions shall also be considered an extension of the Instructions to Bidders. Executive Orders, Wage Determination, and any and all

INSTRUCTIONS TO BIDDERS
COMMONWEALTH OF KENTUCKY
January 2015

other items set out in the Supplementary Conditions shall be used in the preparation of the Bid.

3. Discrepancy - Bid Price

In some instances, there will be space in the BID FORM for the bid price to be written in both words and figures. In such cases, the price written in words shall include both dollars and cents and will be considered the correct price in case of a discrepancy between it and the price written in figures. In case of a discrepancy, the correct total bid price will be considered to be the sum total of amounts bid for all items in the BID FORM. The correct product of the quantity listed in the BID FORM for the said item multiplied by the unit price bid shall be used in the total bid.

4. Qualifications of Bidders

The Contractors bidding on the work shall give evidence of their experience in the class of work involved, including at least one job of comparable size and type performed by them as general contractors.

BID FORMS submitted by Contractors who have not, in the opinion of the Engineer and/or Owner, had sufficient experience in the size and type work involved may not be considered.

5. Bid Guaranty

The Bidder shall accompany his BID FORM with the BID BOND in the amount not less than five (5%) percent of the amount of his bid executed on the form furnished as a part of the Contract Documents or with a certified check in the amount not less than five (5%) percent of the amount of his bid. A Power of Attorney of the person signing the Bid Bond shall be included. All such documents are subject to approval by the Owner's attorney and the Agency providing funding, if such funding is involved. It is assumed that the Surety Company executing the Bid Bond will also execute the Contract Bond if the Bid is accepted. If this is not to be the case, the approval of the Owner's attorney will be prerequisite to award of the contract. If a certified check is used as Bid Guaranty, the Bidder shall submit the name of his proposed surety with his BID FORM or in writing within five (5) days after being requested to do so.

INSTRUCTIONS TO BIDDERS
COMMONWEALTH OF KENTUCKY
January 2015

6. Contract Surety; Performance and Payment Bonds

The successful Bidder will be required to furnish both a Performance Bond and a Payment Bond executed by a Surety Company duly authorized to do business in the state in which the work is to be performed and acceptable to the Owner's attorney and the Agency providing funds, if such funding is involved, and each in an amount not less than 100% of the Contract price as security for the faithful performance of this Contract and as security for the payment of all persons performing labor and furnishing materials in connection with this Contract. THESE BONDS MUST BE EXECUTED IN THE FORM PROVIDED AS PART OF THE CONTRACT DOCUMENTS.

7. Interpretation of Contract Documents

The Construction Contract and the Detailed Specifications contain the provisions required for the construction of the project. No information obtained from any officer, agent or employee of the Owner on any such matters shall in any way affect the risk or obligation assumed by the Contractor or relieve him from fulfilling any of the conditions of the Contract.

If any Contractor contemplating the submission of a bid for the proposed contract is in doubt as to the true meaning of any part of the Plans, Specifications, or other proposed Contract Documents, he should submit a written request for an interpretation thereof to J. R. Wauford & Company, Consulting Engineers, Inc., P.O. Box 140350, 2835 Lebanon Road, Nashville, Tennessee 37214, telephone 615-883-3243, fax 615-391-3710. The person making the request will be responsible for its prompt delivery. Any interpretation of the Contract Documents will be made only by written communication and in accordance with the time constraints of Commonwealth law. The Owner and/or the Engineer will not be responsible for explanation or interpretations of the proposed documents except as issued in accordance herewith.

8. Modifications of Bids

Bidders will not be allowed to modify their bids by telegraphic or facsimile communication. A bidder may withdraw a mailed bid prior to the bid opening by contacting the Owner; however, neither the Owner nor the Engineer will be responsible for processing this request.

INSTRUCTIONS TO BIDDERS
COMMONWEALTH OF KENTUCKY
January 2015

9. Second Hand and Salvaged Materials

The use of second hand and/or salvaged materials will not be permitted unless specifically provided for in the Specifications.

10. Award of Contract - Kentucky

The Owner reserves the right to reject all bids and to waive informalities. In the event that the lowest Bidder's price overruns the Owner's budget, the Owner reserves the right to negotiate with a portion of or all Bidders. In the event that the low bid is within the Owner's budget, the Contract will be awarded to the lowest responsive and responsible Bidder.

The Owner intends to award a Contract to the Contractor whose bid, confirming to the BID FORM, is the most advantageous on the basis of "best value" for all products, services, and requirements contained herein.

An evaluation committee or a designated individual will evaluate the information provided by the Contractor in response to the established measurable criteria contained herein.

Measureable Criteria:

Price 100 Points

TOTAL POINTS 100 Points

Each Contractor is responsible for submitting all relevant, factual and correct information with the Bid to enable the evaluator(s) to afford each Contractor the maximum score based on the available data submitted by the Contractor. The Contractor shall explicitly adhere to the BID FORM which contains adequate space for the Contractor's pricing.

Bid Price (100 Points)

The bidder with the lowest Bid Price receives the maximum score. The bidder with the next lowest Price receives points by dividing the lowest Price by the next lowest Price and multiplying that percentage by the available points. For Example, 100 points is allocated to the lowest Price criteria for this procurement. Bidder "A" bids \$3.00 as the lowest bidder and receives the maximum 100 points ($\$3.00 / \$3.00 = 1.00 \times 100 = 100$). Assume Bidder "B" is next lowest bidder at \$4.00, then "B" receives 75 points ($\$3.00 / \$4.00 = .75$).

INSTRUCTIONS TO BIDDERS
COMMONWEALTH OF KENTUCKY
January 2015

Best Value scoring is subject to **Reciprocal preference for Kentucky resident bidders and Preferences for a Qualified Bidder of the Department of Corrections, Division of Prison Industries (KAR 200 5:410).**

The Contractor is required to submit a complete copy of the "Required Affidavit for Bidders, Offerors and Contractors Claiming Resident Bidder Status" and "Required Affidavit for Bidders, Offerors and Contractors Claiming Qualified Bidder Status" attached to the BID FORM.

11. Execution of Contracts

The construction Contract and Performance and Payment Bond(s) shall be executed by the successful Bidder within the time specified in BID FORM. The number of copies to be executed will be specified in the BID FORM.

12. Liquidated Damages for Failure to Enter into Contract

The successful Bidder, upon his failure or refusal to execute and deliver the Contract and Bonds required within ten (10) days after he has been mailed registered notice of the acceptance of his Bid, shall forfeit to the Owner, as liquidated damages for such failure or refusal, the security deposited with his Bid.

13. Insurance, Contractor's Coverage and Cancellation Provision (Also see General Conditions Article 6)

The Contractor will not be permitted to commence work until he has obtained all insurance required by the Contract Documents and such insurance has been approved by the Engineer and/or Owner, nor shall the Contractor allow any Subcontractor to commence work until all similar insurance required of the Subcontractor has been so obtained.

If a Subcontractor does not take out insurance in his own name and his principal Contractor wished to provide insurance protection for such Subcontractor and such Subcontractor's employees, an endorsement must be attached to the principal Contractor's policy which endorsement must identify the persons thereby covered, or else the principal Contractor must take out appropriate policies in the name of the Subcontractor.

Each policy of insurance covering the Contractor's or Subcontractor's operations under the Contract shall provide, either in the body of the policy, or by appropriate endorsement to the policy, that such policy cannot be altered or canceled in less

INSTRUCTIONS TO BIDDERS
COMMONWEALTH OF KENTUCKY
January 2015

than thirty (30) days after the receipt of written notice of such alteration or cancellation to the assured (insured) and the Owner and Engineer.

Certificates of insurance coverages shall include a statement of the alteration or cancellation provision of the policy, sufficient to show definitely that such provisions comply with the requirements stated herein.

THE CONTRACTOR SHALL BE FULLY RESPONSIBLE FOR MAINTAINING THE INSURANCE HEREIN REQUIRED AND SHALL SAVE HARMLESS THE OWNER AND/OR ENGINEER IN THE EVENT HE NEGLECTS OR FAILS TO DO SO FOR ANY REASON. IN THE EVENT THAT THE APPROVED INSURER DOES NOT RENEW THE REQUIRED POLICY AT ANY TIME DURING THE TERM OF THIS CONTRACT, THE CONTRACTOR SHALL CEASE ALL WORK ON THE CONTRACT UNTIL NEW INSURANCE IS ACQUIRED AND APPROVED BY THE OWNER.

14. Insurance: Commercial General Liability, Automobile Liability and Excess Liability (Also see General Conditions Article 6)

The Contractor shall take out and maintain during the life of this contract Commercial General Liability, Automobile Liability, and Excess Liability insurance as shall protect himself and any subcontractor performing work covered under this Contract from claims for damages because of bodily injury, including accidental death, and from claims for property damages that may arise from operations under this Contract, whether such operations be by him or by any subcontractor, or by anyone directly or indirectly employed by either of them.

The Contractor's Commercial or Comprehensive General Liability insurance coverage shall provide coverage on an "occurrence" basis and aggregate limits of insurance on a "per project" basis; and shall specifically include premises and operations; underground, explosion and collapse; products and completed operations maintained two years after completion of the contract; broad form contractual; independent contractors; broad form property damage; and personal injury coverage. If the Comprehensive General Liability Form is used, the policy must include the Broad Form Comprehensive General Liability Endorsement.

Automobile liability insurance must be provided by a Comprehensive Automobile Liability policy covering all owned, hired and non-owned vehicles.

Excess liability insurance must be provided by an Umbrella form on an "occurrence" basis.

The Contractor's Commercial General Liability, Automobile Liability and Excess Liability insurance shall insure the Owner and the Engineer. The insurance

INSTRUCTIONS TO BIDDERS
COMMONWEALTH OF KENTUCKY
January 2015

coverage of the Owner and the Engineer shall be provided by endorsement that the Owner and the Engineer are additional insureds on the Contractor's General Liability Policy, Automobile Liability Policy and Excess Liability Policy; or by a separate "Owners Protection Policy." If the Owner and the Engineer are listed as additional insureds on the General Liability Policy, this shall be accomplished using the CG 20-10-11-85 or its equivalent. The Owner and the Engineer shall be listed on the endorsement or separate policy using their respective full legal names.

Minimum limits of coverage shall be as follows:

General Liability

(1)	General Aggregate per Project.....	\$2,000,000
(2)	Each Occurrence.....	\$1,000,000
(3)	Products/Completed Operations Aggregate.....	\$2,000,000
(4)	Medical Expense (any one person).....	\$10,000

Automobile Liability

Combined Single Limit Bodily Injury and Property Damage..... \$1,000,000

Umbrella

Combined Single Limit Bodily Injury and Property Damage \$2,000,000
(Each Occurrence)

The above does not include special insurance requirements of entities whose property or personnel or other interests are involved; these requirements where applicable will be set forth in the Detailed Specifications.

15. Insurance: Workmen's Compensation and Employer's Liability (Also see General Conditions Article 6)

The Contractor shall take out and maintain, during the life of this contract, Workmen's Compensation and Employer's Liability Insurance, including occupational disease provisions, for all of his employees employed at the site of the project, and in case any work is sublet, the Contractor shall require the subcontractor similarly to provide Workmen's Compensation Insurance and Employer's Liability Insurance, including occupational disease provisions, for all the latter's employees unless such employees are covered by the protection afforded by the Contractor.

INSTRUCTIONS TO BIDDERS
COMMONWEALTH OF KENTUCKY
January 2015

In case any class of employees engaged in hazardous work under this contract at the site of the project is not protected under Kentucky statute, the Contractor shall provide, and shall cause each subcontractor to provide, adequate coverage for the protection of his employees not otherwise protected.

Minimum limits of coverage shall be as follows unless required otherwise by prevailing local statute:

Worker's Compensation

Statutory limits required by the Commonwealth of Kentucky

Employer's Liability

Each Accident.....	\$ 100,000
Disease (policy limit)	\$ 500,000
Disease (each employee)	\$ 100,000

16. Insurance: Builders Risk (Also see General Conditions Article 6)

The Contractor shall provide Builders Risk Insurance (fire and extended coverage) for 100 percent of the insurable portion of all work in place and/or materials stored at the site. Such insurance shall provide coverage at all times for the full cash value of all completed construction and/or materials stored and shall remain in effect until the covered facilities are accepted by the Owner. Unless otherwise noted, all portions of the construction shall be covered on a 100 percent complete value basis. The Builders Risk Insurance provided by the Contractor shall cover damage to materials and equipment occurring during offloading and/or installation, regardless of the entity performing the offloading and/or installation.

The Contractor will be responsible for any losses covered by the Builder's Risk insurance policy up to the per occurrence deductible amount.

17. Certificate of Insurance (Also see General Conditions Article 6)

As a minimum, the Certificate of Insurance shall contain the following information: (1) name of insurance company, (2) policy number and liability limits on all policies, (3) date of expiration of all policies, (4) statement that ten days' notice of cancellation will be given to the Owner and the Engineer, and (5) statement that coverage that will hold the Owner and Engineer harmless for acts of the Contractor is included.

INSTRUCTIONS TO BIDDERS
COMMONWEALTH OF KENTUCKY
January 2015

18. Sanitary Facilities

The Contractor shall furnish, install and maintain ample sanitary facilities for the workmen. As the needs arise, enclosed temporary toilets in sufficient number shall be placed as directed by the Engineer. Permanent toilets installed under this Contract shall not be used during construction. Drinking water shall be provided from a proved safe source, so piped or transported as to be kept clean and fresh and served from single service containers of satisfactory types. The inclusion of this article in no way obligates the Owner or the Engineer to make verification of or to inspect the sanitary facilities and the Contractor shall save the Owner and/or Engineer harmless from any claims arising therefrom.

19. Lands and Rights-of-Way

It is anticipated that all easements and land required for the construction of this project will be acquired before the issuance of a Work Order or within the period stipulated in the Advertisement for Bids during which Contractors are not allowed to withdraw their bids. Unless the land(s) and/or easements are obtained or the Contractor agrees to either an extension or a work order stipulating the limitations of work or he may withdraw his bid at the end of such period stipulated in the Advertisement for Bids.

20. Commencement and Completion of Work

See General Conditions Article 4.

21. Funds for Partial Payment Estimates

See General Conditions Article 15.

22. Construction Records and Reports

The Contractor shall, upon request, furnish the Owner with proof that all payrolls for services rendered and invoices for materials supplied have been duly paid as herein required and such other pertinent data as the Owner may require.

The Owner or his authorized representatives and agents shall be permitted to inspect all payrolls, records of personnel, invoices of materials, and other relevant data and records.

INSTRUCTIONS TO BIDDERS
COMMONWEALTH OF KENTUCKY
January 2015

On projects involving Federal or Commonwealth Funds, the Federal or Commonwealth Agency or Agencies participating in the project shall be considered representatives of the Owner.

23. Payment of Employees

The Contractor and each of his Subcontractors shall pay each of his employees engaged in work on the project in full (less deductions made mandatory by law), in cash (or check), and not less often than once each week.

24. Extra Work

Any departure from the original Contract will be made at the Contract unit prices shown in the BID FORM if ordered by the Engineer or by Change Order as provided in the appropriate paragraphs of the General Conditions or the Supplementary Conditions.

25. Final Payment

Final payment to the Contractor will be made in accordance with the details set out hereinafter under General Conditions or in the Supplementary Conditions.

26. Laws and Regulations

The Bidder's attention is directed to the fact that all applicable Commonwealth laws, municipal ordinances, and the rules and regulations of all authorities having jurisdiction over construction of the project shall apply to the Contract throughout, and they will be deemed to be included in the Contract the same as though herein written out in full.

27. Subcontracts

See General Conditions Article 7.

In addition to the requirements of the laws of the Commonwealth in which the project is located, no Bid will be accepted from any Contractor who does not propose to accomplish the major portion of the work with his own forces and under his own supervision.

INSTRUCTIONS TO BIDDERS
COMMONWEALTH OF KENTUCKY
January 2015

28. Wages and Hours and Non-Discrimination

The Contractor shall conform in every respect to applicable rules, regulations and statues pertaining to wages, hours or work, and non-discrimination. If required, a Wage Determination Decision will be included in these bound documents or may be added by Addendum.

STANDARD GENERAL CONDITIONS OF THE CONSTRUCTION CONTRACT

Prepared by

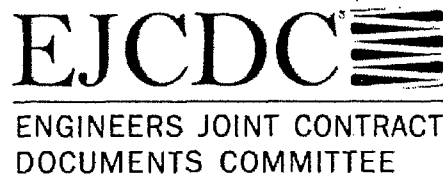

Issued and Published Jointly by



Alterations or Deletions generated by
J. R. Wauford & Company, Consulting Engineers, Inc.
are shown in this font

Copyright © 2013:

National Society of Professional Engineers
1420 King Street, Alexandria, VA 22314-2794
(703) 684-2882
www.nspe.org

American Council of Engineering Companies
1015 15th Street N.W., Washington, DC 20005
(202) 347-7474
www.acec.org

American Society of Civil Engineers
1801 Alexander Bell Drive, Reston, VA 20191-4400
(800) 548-2723
www.asce.org

The copyright for this document is owned jointly by the three sponsoring organizations listed above. The National Society of Professional Engineers is the Copyright Administrator for the EJCDC documents; please direct all inquiries regarding EJCDC copyrights to NSPE.

**STANDARD GENERAL CONDITIONS OF THE
CONSTRUCTION CONTRACT**

TABLE OF CONTENTS

	Page
ARTICLE 1 – Definitions and Terminology.....	1
1.01 Defined Terms.....	1
1.02 Terminology.....	5
ARTICLE 2 – Preliminary Matters.....	6
2.01 Delivery of Bonds and Evidence of Insurance.....	6
2.02 Copies of Documents.....	7
2.03 Before Starting Construction.....	7
2.04 Preconstruction Conference; Designation of Authorized Representatives.....	7
2.05 Initial Acceptance of Schedules.....	7
2.06 Electronic Transmittals (from 2007 EJCDC C-700 Standard General Conditions).....	8
ARTICLE 3 – Documents: Intent, Requirements, Reuse.....	8
3.01 Intent.....	8
3.02 Reference Standards.....	8
3.03 Reporting and Resolving Discrepancies.....	9
3.04 Requirements of the Contract Documents.....	10
3.05 Reuse of Documents.....	10
ARTICLE 4 – Commencement and Progress of the Work.....	11
4.01 Commencement of Contract Times; Notice to Proceed.....	11
4.02 Starting the Work.....	11
4.03 Reference Points.....	11
4.04 Progress Schedule.....	11
4.05 Delays in Contractor’s Progress.....	11
ARTICLE 5 – Availability of Lands; Subsurface and Physical Conditions; Hazardous Environmental Conditions.....	12
5.01 Availability of Lands.....	12
5.02 Use of Site and Other Areas.....	13
5.03 Subsurface and Physical Conditions.....	14
5.04 Differing Subsurface or Physical Conditions.....	14
5.05 Underground Facilities.....	16
5.06 Hazardous Environmental Conditions at Site.....	17
ARTICLE 6 – Bonds and Insurance (Also see Instructions to Bidders).....	19

6.01	Performance, Payment, and Other Bonds	19
6.02	Insurance—General Provisions	20
6.03	Contractor’s Insurance	21
6.04	Owner’s Liability Insurance	24
6.05	Property Insurance.....	24
6.06	Waiver of Rights	26
6.07	Receipt and Application of Property Insurance Proceeds	27
ARTICLE 7 – Contractor’s Responsibilities.....		27
7.01	Supervision and Superintendence	27
7.02	Labor; Working Hours	28
7.03	Services, Materials, and Equipment	28
7.04	“Or Equals”	28
7.05	Substitutes	29
7.06	Concerning Subcontractors, Suppliers, and Others (Also see Specifications Section 1).....	31
7.07	Patent Fees and Royalties.....	32
7.08	Permits.....	33
7.09	Taxes	33
7.10	Laws and Regulations	33
7.11	Record Documents	34
7.12	Safety and Protection	34
7.13	Safety Representative.....	35
7.14	Hazard Communication Programs	35
7.15	Emergencies	35
7.16	Shop Drawings, Samples, and Other Submittals.....	35
7.17	Contractor’s General Warranty and Guarantee	38
7.18	Indemnification	38
7.19	Delegation of Professional Design Services	39
ARTICLE 8 – Other Work at the Site		40
8.01	Other Work.....	40
8.02	Coordination.....	40
8.03	Legal Relationships	41
ARTICLE 9 – Owner’s Responsibilities.....		42
9.01	Communications to Contractor	42
9.02	Replacement of Engineer	42
9.03	Furnish Data	42

9.04	Pay When Due.....	42
9.05	Lands and Easements; Reports, Tests, and Drawings.....	42
9.06	Insurance	42
9.07	Change Orders.....	42
9.08	Inspections, Tests, and Approvals.....	42
9.09	Limitations on Owner’s Responsibilities	43
9.10	Undisclosed Hazardous Environmental Condition	43
9.11	Evidence of Financial Arrangements	43
9.12	Safety Programs	43
ARTICLE 10 – Engineer’s Status During Construction		43
10.01	Owner’s Representative	43
10.02	Visits to Site	43
10.03	Project Representative.....	44
10.04	Rejecting Defective Work.....	44
10.05	Shop Drawings, Change Orders and Payments.....	44
10.06	Determinations for Unit Price Work	44
10.07	Decisions on Requirements of Contract Documents and Acceptability of Work	44
10.08	Limitations on Engineer’s Authority and Responsibilities	44
10.09	Compliance with Safety Program.....	45
ARTICLE 11 – Amending the Contract Documents; Changes in the Work.....		45
11.01	Amending and Supplementing Contract Documents	45
11.02	Owner-Authorized Changes in the Work.....	46
11.03	Unauthorized Changes in the Work	46
11.04	Change of Contract Price	46
11.05	Change of Contract Times.....	48
11.06	Change Proposals	48
11.07	Execution of Change Orders	49
11.08	Notification to Surety.....	49
ARTICLE 12 – Claims		49
12.01	Claims	49
ARTICLE 13 – Cost of the Work; Allowances; Unit Price Work		51
13.01	Cost of the Work	51
13.02	Allowances	53
13.03	Unit Price Work	54

ARTICLE 14 – Tests and Inspections; Correction, Removal or Acceptance of Defective Work 54

14.01 Access to Work 54

14.02 Tests, Inspections, and Approvals 55

14.03 Defective Work 55

14.04 Acceptance of Defective Work 56

14.05 Uncovering Work 56

14.06 Owner May Stop the Work 57

14.07 Owner May Correct Defective Work 57

ARTICLE 15 – Payments to Contractor; Set-Offs; Completion; Correction Period 58

15.01 Progress Payments 58

15.02 Contractor’s Warranty of Title 61

15.03 Substantial Completion 61

15.04 Partial Use or Occupancy 62

15.05 Final Inspection 63

15.06 Final Payment 63

15.07 Waiver of Claims 64

15.08 Correction Period 64

ARTICLE 16 – Suspension of Work and Termination 65

16.01 Owner May Suspend Work 65

16.02 Owner May Terminate for Cause 65

16.03 Owner May Terminate For Convenience 66

16.04 Contractor May Stop Work or Terminate 67

ARTICLE 17 – Final Resolution of Disputes 67

17.01 Methods and Procedures 67

ARTICLE 18 – Miscellaneous 68

18.01 Giving Notice 68

18.02 Computation of Times 68

18.03 Cumulative Remedies 68

18.04 Limitation of Damages 68

18.05 No Waiver 68

18.06 Survival of Obligations 68

18.07 Controlling Law 69

18.08 Headings 69

ARTICLE 1 – DEFINITIONS AND TERMINOLOGY

1.01 *Defined Terms*

- A. Wherever used in the Bidding Requirements or Contract Documents, a term printed with initial capital letters, including the term's singular and plural forms, will have the meaning indicated in the definitions below. In addition to terms specifically defined, terms with initial capital letters in the Contract Documents include references to identified articles and paragraphs, and the titles of other documents or forms.
1. *Addenda*—Written or graphic instruments issued prior to the opening of Bids which clarify, correct, or change the Bidding Requirements or the proposed Contract Documents.
 2. *Agreement*—The written instrument, executed by Owner and Contractor, that sets forth the Contract Price and Contract Times, identifies the parties and the Engineer, and designates the specific items that are Contract Documents.
 3. *Application for Payment*—The form acceptable to Engineer which is to be used by Contractor during the course of the Work in requesting progress or final payments and which is to be accompanied by such supporting documentation as is required by the Contract Documents.
 4. *Bid*—The offer of a Bidder submitted on the prescribed form setting forth the prices for the Work to be performed.
 5. *Bidder*—An individual or entity that submits a Bid to Owner.
 6. *Bidding Documents*—The Bidding Requirements, the proposed Contract Documents, and all Addenda.
 7. *Bidding Requirements*—The advertisement or invitation to bid, Instructions to Bidders, Bid Bond or other Bid security, if any, the Bid Form, and the Bid with any attachments.
 8. *Change Order*—A document which is signed by Contractor and Owner and authorizes an addition, deletion, or revision in the Work or an adjustment in the Contract Price or the Contract Times, or other revision to the Contract, issued on or after the Effective Date of the Contract.
 9. *Change Proposal*—A written request by Contractor, duly submitted in compliance with the procedural requirements set forth herein, seeking an adjustment in Contract Price or Contract Times, or both; contesting an initial decision by Engineer concerning the requirements of the Contract Documents or the acceptability of Work under the Contract Documents; challenging a set-off against payments due; or seeking other relief with respect to the terms of the Contract.
 10. *Claim*—(a) A demand or assertion by Owner directly to Contractor, duly submitted in compliance with the procedural requirements set forth herein: seeking an adjustment of Contract Price or Contract Times, or both; contesting an initial decision by Engineer concerning the requirements of the Contract Documents or the acceptability of Work under the Contract Documents; contesting Engineer's decision regarding a Change Proposal; seeking resolution of a contractual issue that Engineer has declined to address; or seeking other relief

with respect to the terms of the Contract; or (b) a demand or assertion by Contractor directly to Owner, duly submitted in compliance with the procedural requirements set forth herein, contesting Engineer's decision regarding a Change Proposal; or seeking resolution of a contractual issue that Engineer has declined to address. A demand for money or services by a third party is not a Claim.

11. *Constituent of Concern*—Asbestos, petroleum, radioactive materials, polychlorinated biphenyls (PCBs), hazardous waste, and any substance, product, waste, or other material of any nature whatsoever that is or becomes listed, regulated, or addressed pursuant to (a) the Comprehensive Environmental Response, Compensation and Liability Act, 42 U.S.C. §§9601 et seq. ("CERCLA"); (b) the Hazardous Materials Transportation Act, 49 U.S.C. §§5501 et seq.; (c) the Resource Conservation and Recovery Act, 42 U.S.C. §§6901 et seq. ("RCRA"); (d) the Toxic Substances Control Act, 15 U.S.C. §§2601 et seq.; (e) the Clean Water Act, 33 U.S.C. §§1251 et seq.; (f) the Clean Air Act, 42 U.S.C. §§7401 et seq.; or (g) any other federal, state, or local statute, law, rule, regulation, ordinance, resolution, code, order, or decree regulating, relating to, or imposing liability or standards of conduct concerning, any hazardous, toxic, or dangerous waste, substance, or material.
12. *Contract*—The entire and integrated written contract between the Owner and Contractor concerning the Work.
13. *Contract Documents*—Those items so designated in the Agreement, and which together comprise the Contract.
14. *Contract Price*—The money that Owner has agreed to pay Contractor for completion of the Work in accordance with the Contract Documents. .
15. *Contract Times*—The number of days or the dates by which Contractor shall: (a) achieve Milestones, if any; (b) achieve Substantial Completion; and (c) complete the Work.
16. *Contractor*—The individual or entity with which Owner has contracted for performance of the Work.
17. *Cost of the Work*—See Paragraph 13.01 for definition.
18. *Drawings (Sometimes called Plans)* —The part of the Contract that graphically shows the scope, extent, and character of the Work to be performed by Contractor.
19. *Effective Date of the Contract*—The date, indicated in the Agreement, on which the Contract becomes effective.
20. *Engineer*—The individual or entity named as such in the Agreement.
21. *Field Order*—A written order issued by Engineer which requires minor changes in the Work but does not change the Contract Price or the Contract Times.
22. *Hazardous Environmental Condition*—The presence at the Site of Constituents of Concern in such quantities or circumstances that may present a danger to persons or property exposed thereto. The presence at the Site of materials that are necessary for the execution of the Work, or that are to be incorporated in the Work, and that are controlled and contained pursuant to industry practices, Laws

and Regulations, and the requirements of the Contract, does not establish a Hazardous Environmental Condition.

23. *Laws and Regulations; Laws or Regulations*—Any and all applicable laws, statutes, rules, regulations, ordinances, codes, and orders of any and all governmental bodies, agencies, authorities, and courts having jurisdiction.
24. *Liens*—Charges, security interests, or encumbrances upon Contract-related funds, real property, or personal property.
25. *Milestone*—A principal event in the performance of the Work that the Contract requires Contractor to achieve by an intermediate completion date or by a time prior to Substantial Completion of all the Work.
26. *Notice of Award*—The written notice by Owner **(or the Engineer)** to a Bidder of Owner's acceptance of the Bid.
27. *Notice to Proceed*—A written notice by Owner **(or the Engineer at the Owner's direction)** to Contractor fixing the date on which the Contract Times will commence to run and on which Contractor shall start to perform the Work.
28. *Owner*—The individual or entity with which Contractor has contracted regarding the Work, and which has agreed to pay Contractor for the performance of the Work, pursuant to the terms of the Contract.
29. *Progress Schedule*—A schedule, prepared and maintained by Contractor, describing the sequence and duration of the activities comprising the Contractor's plan to accomplish the Work within the Contract Times.
30. *Project*—The total undertaking to be accomplished for Owner by engineers, contractors, and others, including planning, study, design, construction, testing, commissioning, and start-up, and of which the Work to be performed under the Contract Documents is a part.
31. *Project Manual*—The written documents prepared for, or made available for, procuring and constructing the Work, including but not limited to the Bidding Documents or other construction procurement documents, geotechnical and existing conditions information, the Agreement, bond forms, General Conditions, Supplementary Conditions, and Specifications. The contents of the Project Manual may be bound in one or more volumes.
32. *Resident Project Representative*—The authorized representative of Engineer assigned to assist Engineer at the Site. As used herein, the term Resident Project Representative or "RPR" includes any assistants or field staff of Resident Project Representative.
33. *Samples*—Physical examples of materials, equipment, or workmanship that are representative of some portion of the Work and that establish the standards by which such portion of the Work will be judged.
34. *Schedule of Submittals*—A schedule, prepared and maintained by Contractor, of required submittals and the time requirements for Engineer's review of the submittals and the performance of related construction activities.

35. *Schedule of Values*—A schedule, prepared and maintained by Contractor, allocating portions of the Contract Price to various portions of the Work and used as the basis for reviewing Contractor's Applications for Payment.
36. *Shop Drawings*—All drawings, diagrams, illustrations, schedules, and other data or information that are specifically prepared or assembled by or for Contractor and submitted by Contractor to illustrate some portion of the Work. Shop Drawings, whether approved or not, are not Drawings and are not Contract Documents.
37. *Site*—Lands or areas indicated in the Contract Documents as being furnished by Owner upon which the Work is to be performed, including rights-of-way and easements, and such other lands furnished by Owner which are designated for the use of Contractor.
38. *Specifications*—The part of the Contract that consists of written requirements for materials, equipment, systems, standards, and workmanship as applied to the Work, and certain administrative requirements and procedural matters applicable to the Work.
39. *Subcontractor*—An individual or entity having a direct contract with Contractor or with any other Subcontractor for the performance of a part of the Work.
40. *Substantial Completion*—The time at which the Work (or a specified part thereof) has progressed to the point where, in the opinion of Engineer, the Work (or a specified part thereof) is sufficiently complete, in accordance with the Contract Documents, so that the Work (or a specified part thereof) can be utilized for the purposes for which it is intended. The terms "substantially complete" and "substantially completed" as applied to all or part of the Work refer to Substantial Completion thereof.
41. *Successful Bidder*—The Bidder whose Bid the Owner accepts, and to which the Owner makes an award of contract, subject to stated conditions.
42. *Supplementary Conditions*—The part of the Contract that amends or supplements these General Conditions.
43. *Supplier*—A manufacturer, fabricator, supplier, distributor, materialman, or vendor having a direct contract with Contractor or with any Subcontractor to furnish materials or equipment to be incorporated in the Work by Contractor or a Subcontractor.
44. *Technical Data*—Those items expressly identified as Technical Data in the Supplementary Conditions, with respect to either (a) subsurface conditions at the Site, or physical conditions relating to existing surface or subsurface structures at the Site (except Underground Facilities) or (b) Hazardous Environmental Conditions at the Site. If no such express identifications of Technical Data have been made with respect to conditions at the Site, then the data contained in boring logs, recorded measurements of subsurface water levels, laboratory test results, and other factual, objective information regarding conditions at the Site that are set forth in any geotechnical or environmental report prepared for the Project and made available to Contractor are hereby defined as Technical Data with respect to conditions at the Site under Paragraphs 5.03, 5.04, and 5.06.

45. *Underground Facilities*—All underground pipelines, conduits, ducts, cables, wires, manholes, vaults, tanks, tunnels, or other such facilities or attachments, and any encasements containing such facilities, including but not limited to those that convey electricity, gases, steam, liquid petroleum products, telephone or other communications, fiber optic transmissions, cable television, water, wastewater, storm water, other liquids or chemicals, or traffic or other control systems.
46. *Unit Price Work*—Work to be paid for on the basis of unit prices.
47. *Work*—The entire construction or the various separately identifiable parts thereof required to be provided under the Contract Documents. Work includes and is the result of performing or providing all labor, services, and documentation necessary to produce such construction; furnishing, installing, and incorporating all materials and equipment into such construction; and may include related services such as testing, start-up, and commissioning, all as required by the Contract Documents.
48. *Work Change Directive*—A written directive to Contractor issued on or after the Effective Date of the Contract, signed by Owner and recommended by Engineer, ordering an addition, deletion, or revision in the Work.

1.02 *Terminology*

- A. The words and terms discussed in the following paragraphs are not defined but, when used in the Bidding Requirements or Contract Documents, have the indicated meaning.
- B. *Intent of Certain Terms or Adjectives:*
 1. The Contract Documents include the terms “as allowed,” “as approved,” “as ordered,” “as directed” or terms of like effect or import to authorize an exercise of professional judgment by Engineer. In addition, the adjectives “reasonable,” “suitable,” “acceptable,” “proper,” “satisfactory,” or adjectives of like effect or import are used to describe an action or determination of Engineer as to the Work. It is intended that such exercise of professional judgment, action, or determination will be solely to evaluate, in general, the Work for compliance with the information in the Contract Documents and with the design concept of the Project as a functioning whole as shown or indicated in the Contract Documents (unless there is a specific statement indicating otherwise). The use of any such term or adjective is not intended to and shall not be effective to assign to Engineer any duty or authority to supervise or direct the performance of the Work, or any duty or authority to undertake responsibility contrary to the provisions of Article 10 or any other provision of the Contract Documents.
- C. *Day:*
 1. The word “day” means a calendar day of 24 hours measured from midnight to the next midnight.
- D. *Defective:*
 1. The word “defective,” when modifying the word “Work,” refers to Work that is unsatisfactory, faulty, or deficient in that it:
 - a. does not conform to the Contract Documents; or

- b. does not meet the requirements of any applicable inspection, reference standard, test, or approval referred to in the Contract Documents; or
 - c. has been damaged prior to Engineer's recommendation of final payment (unless responsibility for the protection thereof has been assumed by Owner at Substantial Completion in accordance with Paragraph 15.03 or 15.04).
- E. *Furnish, Install, Perform, Provide:*
1. The word "furnish," when used in connection with services, materials, or equipment, shall mean to supply and deliver said services, materials, or equipment to the Site (or some other specified location) ready for use or installation and in usable or operable condition.
 2. The word "install," when used in connection with services, materials, or equipment, shall mean to put into use or place in final position said services, materials, or equipment complete and ready for intended use.
 3. The words "perform" or "provide," when used in connection with services, materials, or equipment, shall mean to furnish and install said services, materials, or equipment complete and ready for intended use.
 4. If the Contract Documents establish an obligation of Contractor with respect to specific services, materials, or equipment, but do not expressly use any of the four words "furnish," "install," "perform," or "provide," then Contractor shall furnish and install said services, materials, or equipment complete and ready for intended use.
- F. Unless stated otherwise in the Contract Documents, words or phrases that have a well-known technical or construction industry or trade meaning are used in the Contract Documents in accordance with such recognized meaning.

ARTICLE 2 – PRELIMINARY MATTERS

2.01 *Delivery of Bonds and Evidence of Insurance*

- A. *Bonds:* When Contractor delivers the executed counterparts of the Agreement to Owner, Contractor shall also deliver to Owner such bonds as Contractor may be required to furnish.
- B. *Evidence of Contractor's Insurance:* When Contractor delivers the executed counterparts of the Agreement to Owner, Contractor shall also deliver to Owner, with copies to each named insured and additional insured (as identified in the Supplementary Conditions or elsewhere in the Contract), the certificates and other evidence of insurance required to be provided by Contractor in accordance with Article 6.
- C. *Evidence of Owner's Insurance:* After receipt of the executed counterparts of the Agreement and all required bonds and insurance documentation, Owner shall promptly deliver to Contractor, with copies to each named insured and additional insured (as identified in the Supplementary Conditions or otherwise), the certificates and other evidence of insurance required to be provided by Owner under Article 6.

2.02 *Copies of Documents*

- A. Owner shall furnish to Contractor two copies of the executed Contract Documents, one of which Contractor shall furnish to Contractor's Surety.
- B. Owner shall furnish to Contractor up to ten printed or hard copies of the Drawings and Project Manual. Additional copies will be furnished upon request at the cost of reproduction.

2.03 *Before Starting Construction*

- A. *Preliminary Schedules:* Within 10 days after the Effective Date of the Contract (or as otherwise specifically required by the Contract Documents), Contractor shall submit to Engineer for timely review:
 - 1. a preliminary Progress Schedule indicating the times (numbers of days or dates) for starting and completing the various stages of the Work, including any Milestones specified in the Contract;
 - 2. a preliminary Schedule of Submittals; and
 - 3. a preliminary Schedule of Values for all of the Work which includes quantities and prices of items which when added together equal the Contract Price and subdivides the Work into component parts in sufficient detail to serve as the basis for progress payments during performance of the Work. Such prices will include an appropriate amount of overhead and profit applicable to each item of Work.

2.04 *Preconstruction Conference; Designation of Authorized Representatives*

- A. Before any Work at the Site is started, a conference attended by Owner, Contractor, Engineer, and others as appropriate will be held to establish a working understanding among the parties as to the Work and to discuss the schedules referred to in Paragraph 2.03.A, procedures for handling Shop Drawings, Samples, and other submittals, processing Applications for Payment, electronic or digital transmittals, and maintaining required records.
- B. At this conference Owner and Contractor each shall designate, in writing, a specific individual to act as its authorized representative with respect to the services and responsibilities under the Contract. Such individuals shall have the authority to transmit and receive information, render decisions relative to the Contract, and otherwise act on behalf of each respective party.

2.05 *Initial Acceptance of Schedules*

- A. At least 10 days before submission of the first Application for Payment a conference, attended by Contractor, Engineer, and others as appropriate, will be held to review for acceptability to Engineer as provided below the schedules submitted in accordance with Paragraph 2.03.A. Contractor shall have an additional 10 days to make corrections and adjustments and to complete and resubmit the schedules. No progress payment shall be made to Contractor until acceptable schedules are submitted to Engineer.
 - 1. The Progress Schedule will be acceptable to Engineer if it provides an orderly progression of the Work to completion within the Contract Times. Such acceptance will not impose on Engineer responsibility for the Progress Schedule, for sequencing, scheduling, or progress of the Work, nor interfere with or relieve Contractor from Contractor's full responsibility therefor.

2. Contractor's Schedule of Submittals will be acceptable to Engineer if it provides a workable arrangement for reviewing and processing the required submittals.
3. Contractor's Schedule of Values will be acceptable to Engineer as to form and substance if it provides a reasonable allocation of the Contract Price to the component parts of the Work.

2.06 *Electronic Transmittals (from 2007 EJCDC C-700 Standard General Conditions)*

- A. **Unless otherwise stated in the Supplementary Conditions, the data furnished by Owner or Engineer to Contractor, or by Contractor to Owner or Engineer, that may be relied upon are limited to the printed copies (also known as hard copies). Files in electronic media format of text, data, graphics, or other types are furnished only for the convenience of the receiving party. Any conclusion or information obtained or derived from such electronic files will be at the user's sole risk. If there is a discrepancy between the electronic files and the hard copies, the hard copies govern.**
- B. **Because data stored in electronic media format can deteriorate or be modified inadvertently or otherwise without authorization of the data's creator, the party receiving electronic files agrees that it will perform acceptance tests or procedures within 60 days, after which the receiving party shall be deemed to have accepted the data thus transferred. Any errors detected within the 60-day acceptance period will be corrected by the transferring party.**
- C. **When transferring documents in electronic media format, the transferring party make no representations as to long term compatibility, usability, or readability of documents resulting from the use of software application packages, operating systems, or computer hardware differing from those used by the data's creator.**

ARTICLE 3 – DOCUMENTS: INTENT, REQUIREMENTS, REUSE

3.01 *Intent*

- A. The Contract Documents are complementary; what is required by one is as binding as if required by all.
- B. It is the intent of the Contract Documents to describe a functionally complete project (or part thereof) to be constructed in accordance with the Contract Documents.
- C. Unless otherwise stated in the Contract Documents, if there is a discrepancy between the electronic or digital versions of the Contract Documents (including any printed copies derived from such electronic or digital versions) and the printed record version, the printed record version shall govern.
- D. The Contract supersedes prior negotiations, representations, and agreements, whether written or oral.
- E. Engineer will issue clarifications and interpretations of the Contract Documents as provided herein.

3.02 *Reference Standards*

- A. Standards Specifications, Codes, Laws and Regulations
 1. Reference in the Contract Documents to standard specifications, manuals, reference standards, or codes of any technical society, organization, or association, or to Laws or Regulations, whether such reference be specific or by implication, shall mean the standard specification, manual, reference standard, code, or Laws or Regulations in effect at the time of opening of Bids (or on the

Effective Date of the Contract if there were no Bids), except as may be otherwise specifically stated in the Contract Documents.

2. No provision of any such standard specification, manual, reference standard, or code, or any instruction of a Supplier, shall be effective to change the duties or responsibilities of Owner, Contractor, or Engineer, or any of their subcontractors, consultants, agents, or employees, from those set forth in the part of the Contract Documents prepared by or for Engineer. No such provision or instruction shall be effective to assign to Owner, Engineer, or any of their officers, directors, members, partners, employees, agents, consultants, or subcontractors, any duty or authority to supervise or direct the performance of the Work or any duty or authority to undertake responsibility inconsistent with the provisions of the part of the Contract Documents prepared by or for Engineer.

3.03 *Reporting and Resolving Discrepancies*

A. *Reporting Discrepancies:*

1. *Contractor's Verification of Figures and Field Measurements:* Before undertaking each part of the Work, Contractor shall carefully study the Contract Documents, and check and verify pertinent figures and dimensions therein, particularly with respect to applicable field measurements. Contractor shall promptly report in writing to Engineer any conflict, error, ambiguity, or discrepancy that Contractor discovers, or has actual knowledge of, and shall not proceed with any Work affected thereby until the conflict, error, ambiguity, or discrepancy is resolved, by a clarification or interpretation by Engineer, or by an amendment or supplement to the Contract Documents issued pursuant to Paragraph 11.01.
2. *Contractor's Review of Contract Documents:* If, before or during the performance of the Work, Contractor discovers any conflict, error, ambiguity, or discrepancy within the Contract Documents, or between the Contract Documents and (a) any applicable Law or Regulation, (b) actual field conditions, (c) any standard specification, manual, reference standard, or code, or (d) any instruction of any Supplier, then Contractor shall promptly report it to Engineer in writing. Contractor shall not proceed with the Work affected thereby (except in an emergency as required by Paragraph 7.15) until the conflict, error, ambiguity, or discrepancy is resolved, by a clarification or interpretation by Engineer, or by an amendment or supplement to the Contract Documents issued pursuant to Paragraph 11.01.
3. Contractor shall not be liable to Owner or Engineer for failure to report any conflict, error, ambiguity, or discrepancy in the Contract Documents unless Contractor had actual knowledge thereof.

B. *Resolving Discrepancies:*

1. Except as may be otherwise specifically stated in the Contract Documents, the provisions of the part of the Contract Documents prepared by or for Engineer shall take precedence in resolving any conflict, error, ambiguity, or discrepancy between such provisions of the Contract Documents and:

- a. the provisions of any standard specification, manual, reference standard, or code, or the instruction of any Supplier (whether or not specifically incorporated by reference as a Contract Document); or
- b. the provisions of any Laws or Regulations applicable to the performance of the Work (unless such an interpretation of the provisions of the Contract Documents would result in violation of such Law or Regulation).

3.04 *Requirements of the Contract Documents*

- A. During the performance of the Work and until final payment, Contractor and Owner shall submit to the Engineer all matters in question concerning the requirements of the Contract Documents (sometimes referred to as requests for information or interpretation—RFIs), or relating to the acceptability of the Work under the Contract Documents, as soon as possible after such matters arise. Engineer will be the initial interpreter of the requirements of the Contract Documents, and judge of the acceptability of the Work thereunder.
- B. Engineer will, with reasonable promptness, render a written clarification, interpretation, or decision on the issue submitted, or initiate an amendment or supplement to the Contract Documents. Engineer's written clarification, interpretation, or decision will be final and binding on Contractor, unless it appeals by submitting a Change Proposal, and on Owner, unless it appeals by filing a Claim.
- C. If a submitted matter in question concerns terms and conditions of the Contract Documents that do not involve (1) the performance or acceptability of the Work under the Contract Documents, (2) the design (as set forth in the Drawings, Specifications, or otherwise), or (3) other engineering or technical matters, then Engineer will promptly give written notice to Owner and Contractor that Engineer is unable to provide a decision or interpretation. If Owner and Contractor are unable to agree on resolution of such a matter in question, either party may pursue resolution as provided in Article 12.

3.05 *Reuse of Documents*

- A. Contractor and its Subcontractors and Suppliers shall not:
 1. have or acquire any title to or ownership rights in any of the Drawings, Specifications, or other documents (or copies of any thereof) prepared by or bearing the seal of Engineer or its consultants, including electronic media editions, or reuse any such Drawings, Specifications, other documents, or copies thereof on extensions of the Project or any other project without written consent of Owner and Engineer and specific written verification or adaptation by Engineer; or
 2. have or acquire any title or ownership rights in any other Contract Documents, reuse any such Contract Documents for any purpose without Owner's express written consent, or violate any copyrights pertaining to such Contract Documents.
- B. The prohibitions of this Paragraph 3.05 will survive final payment, or termination of the Contract. Nothing herein shall preclude Contractor from retaining copies of the Contract Documents for record purposes.

ARTICLE 4 – COMMENCEMENT AND PROGRESS OF THE WORK**4.01 Commencement of Contract Times; Notice to Proceed**

- A. The Contract Times will commence to run on the thirtieth day after the Effective Date of the Contract or, if a Notice to Proceed is given, on the day indicated in the Notice to Proceed. A Notice to Proceed may be given at any time within 30 days after the Effective Date of the Contract. **(last sentence deleted)**

4.02 Starting the Work

- A. Contractor shall start to perform the Work on the date when the Contract Times commence to run. No Work shall be done at the Site prior to such date.

4.03 Reference Points

- A. Owner shall provide engineering surveys to establish reference points for construction which in Engineer's judgment are necessary to enable Contractor to proceed with the Work. Contractor shall be responsible for laying out the Work, shall protect and preserve the established reference points and property monuments, and shall make no changes or relocations without the prior written approval of Owner. Contractor shall report to Engineer whenever any reference point or property monument is lost or destroyed or requires relocation because of necessary changes in grades or locations, and shall be responsible for the accurate replacement or relocation of such reference points or property monuments by professionally qualified personnel.

4.04 Progress Schedule

- A. Contractor shall adhere to the Progress Schedule established in accordance with Paragraph 2.05 as it may be adjusted from time to time as provided below.
1. Contractor shall submit to Engineer for acceptance (to the extent indicated in Paragraph 2.05) proposed adjustments in the Progress Schedule that will not result in changing the Contract Times.
 2. Proposed adjustments in the Progress Schedule that will change the Contract Times shall be submitted in accordance with the requirements of Article 11.
- B. Contractor shall carry on the Work and adhere to the Progress Schedule during all disputes or disagreements with Owner. No Work shall be delayed or postponed pending resolution of any disputes or disagreements, or during any appeal process, except as permitted by Paragraph 16.04, or as Owner and Contractor may otherwise agree in writing.

4.05 Delays in Contractor's Progress

- A. If Owner, Engineer, or anyone for whom Owner is responsible, delays, disrupts, or interferes with the performance or progress of the Work, then Contractor shall be entitled to an equitable adjustment in the Contract Times and Contract Price. Contractor's entitlement to an adjustment of the Contract Times is conditioned on such adjustment being essential to Contractor's ability to complete the Work within the Contract Times.

- B. Contractor shall not be entitled to an adjustment in Contract Price or Contract Times for delay, disruption, or interference caused by or within the control of Contractor. Delay, disruption, and interference attributable to and within the control of a Subcontractor or Supplier shall be deemed to be within the control of Contractor.
- C. If Contractor's performance or progress is delayed, disrupted, or interfered with by unanticipated causes not the fault of and beyond the control of Owner, Contractor, and those for which they are responsible, then Contractor shall be entitled to an equitable adjustment in Contract Times. Contractor's entitlement to an adjustment of the Contract Times is conditioned on such adjustment being essential to Contractor's ability to complete the Work within the Contract Times. Such an adjustment shall be Contractor's sole and exclusive remedy for the delays, disruption, and interference described in this paragraph. Causes of delay, disruption, or interference that may give rise to an adjustment in Contract Times under this paragraph include but are not limited to the following:
1. severe and unavoidable natural catastrophes such as fires, floods, epidemics, and earthquakes;
 2. abnormal weather conditions;
 3. acts or failures to act of utility owners (other than those performing other work at or adjacent to the Site by arrangement with the Owner, as contemplated in Article 8); and
 4. acts of war or terrorism.
- D. Delays, disruption, and interference to the performance or progress of the Work resulting from the existence of a differing subsurface or physical condition, an Underground Facility that was not shown or indicated by the Contract Documents, or not shown or indicated with reasonable accuracy, and those resulting from Hazardous Environmental Conditions, are governed by Article 5.
- E. Paragraph 8.03 governs delays, disruption, and interference to the performance or progress of the Work resulting from the performance of certain other work at or adjacent to the Site.
- F. Contractor shall not be entitled to an adjustment in Contract Price or Contract Times for any delay, disruption, or interference if such delay is concurrent with a delay, disruption, or interference caused by or within the control of Contractor.
- G. Contractor must submit any Change Proposal seeking an adjustment in Contract Price or Contract Times under this paragraph within 30 days of the commencement of the delaying, disrupting, or interfering event.

ARTICLE 5 – AVAILABILITY OF LANDS; SUBSURFACE AND PHYSICAL CONDITIONS; HAZARDOUS ENVIRONMENTAL CONDITIONS

5.01 *Availability of Lands*

- A. Owner shall furnish the Site. Owner shall notify Contractor of any encumbrances or restrictions not of general application but specifically related to use of the Site with which Contractor must comply in performing the Work.

- B. Upon reasonable written request, Owner shall furnish Contractor with a current statement of record legal title and legal description of the lands upon which permanent improvements are to be made and Owner's interest therein as necessary for giving notice of or filing a mechanic's or construction lien against such lands in accordance with applicable Laws and Regulations.
- C. Contractor shall provide for all additional lands and access thereto that may be required for temporary construction facilities or storage of materials and equipment.

5.02 Use of Site and Other Areas

A. *Limitation on Use of Site and Other Areas:*

1. Contractor shall confine construction equipment, temporary construction facilities, the storage of materials and equipment, and the operations of workers to the Site, adjacent areas that Contractor has arranged to use through construction easements or otherwise, and other adjacent areas permitted by Laws and Regulations, and shall not unreasonably encumber the Site and such other adjacent areas with construction equipment or other materials or equipment. Contractor shall assume full responsibility for (a) damage to the Site; (b) damage to any such other adjacent areas used for Contractor's operations; (c) damage to any other adjacent land or areas; and (d) for injuries and losses sustained by the owners or occupants of any such land or areas; provided that such damage or injuries result from the performance of the Work or from other actions or conduct of the Contractor or those for which Contractor is responsible.
 2. If a damage or injury claim is made by the owner or occupant of any such land or area because of the performance of the Work, or because of other actions or conduct of the Contractor or those for which Contractor is responsible, Contractor shall (a) take immediate corrective or remedial action as required by Paragraph 7.12, or otherwise; (b) promptly attempt to settle the claim as to all parties through negotiations with such owner or occupant, or otherwise resolve the claim by arbitration or other dispute resolution proceeding, or at law; and (c) to the fullest extent permitted by Laws and Regulations, indemnify and hold harmless Owner and Engineer, and the officers, directors, members, partners, employees, agents, consultants and subcontractors of each and any of them from and against any such claim, and against all costs, losses, and damages (including but not limited to all fees and charges of engineers, architects, attorneys, and other professionals and all court or arbitration or other dispute resolution costs) arising out of or relating to any claim or action, legal or equitable, brought by any such owner or occupant against Owner, Engineer, or any other party indemnified hereunder to the extent caused directly or indirectly, in whole or in part by, or based upon, Contractor's performance of the Work, or because of other actions or conduct of the Contractor or those for which Contractor is responsible.
- B. *Removal of Debris During Performance of the Work:* During the progress of the Work the Contractor shall keep the Site and other adjacent areas free from accumulations of waste materials, rubbish, and other debris. Removal and disposal of such waste materials, rubbish, and other debris shall conform to applicable Laws and Regulations.
 - C. *Cleaning:* Prior to Substantial Completion of the Work Contractor shall clean the Site and the Work and make it ready for utilization by Owner. At the completion of the Work Contractor shall remove from the Site and adjacent areas all tools, appliances,

construction equipment and machinery, and surplus materials and shall restore to original condition all property not designated for alteration by the Contract Documents.

- D. *Loading of Structures*: Contractor shall not load nor permit any part of any structure to be loaded in any manner that will endanger the structure, nor shall Contractor subject any part of the Work or adjacent structures or land to stresses or pressures that will endanger them.

5.03 *Subsurface and Physical Conditions*

- A. *Reports and Drawings*: The Supplementary Conditions identify:

1. those reports **provided by** Owner of explorations and tests of subsurface conditions at or adjacent to the Site;
2. those drawings **provided by** Owner of physical conditions relating to existing surface or subsurface structures at the Site (except Underground Facilities); and
3. Technical Data contained in such reports and drawings.

- B. *Reliance by Contractor on Technical Data Authorized*: Contractor may rely upon the accuracy of the Technical Data expressly identified in the Supplementary Conditions with respect to such reports and drawings, but such reports and drawings are not Contract Documents. If no such express identification has been made, then Contractor may rely upon the accuracy of the Technical Data (as defined in Article 1) contained in any geotechnical or environmental report prepared for the Project and made available to Contractor. Except for such reliance on Technical Data, Contractor may not rely upon or make any claim against Owner or Engineer, or any of their officers, directors, members, partners, employees, agents, consultants, or subcontractors, with respect to:

1. the completeness of such reports and drawings for Contractor's purposes, including, but not limited to, any aspects of the means, methods, techniques, sequences, and procedures of construction to be employed by Contractor, and safety precautions and programs incident thereto; or
2. other data, interpretations, opinions, and information contained in such reports or shown or indicated in such drawings; or
3. any Contractor interpretation of or conclusion drawn from any Technical Data or any such other data, interpretations, opinions, or information.

5.04 *Differing Subsurface or Physical Conditions*

- A. *Notice by Contractor*: If Contractor believes that any subsurface or physical condition that is uncovered or revealed at the Site either:

1. is of such a nature as to establish that any Technical Data on which Contractor is entitled to rely as provided in Paragraph 5.03 is materially inaccurate; or
2. is of such a nature as to require a change in the Drawings or Specifications; or
3. differs materially from that shown or indicated in the Contract Documents; or
4. is of an unusual nature, and differs materially from conditions ordinarily encountered and generally recognized as inherent in work of the character provided for in the Contract Documents;

then Contractor shall, promptly after becoming aware thereof and before further disturbing the subsurface or physical conditions or performing any Work in connection therewith (except in an emergency as required by Paragraph 7.15), notify Owner and Engineer in writing about such condition. Contractor shall not further disturb such condition or perform any Work in connection therewith (except with respect to an emergency) until receipt of a written statement permitting Contractor to do so.

- B. *Engineer's Review:* After receipt of written notice as required by the preceding paragraph, Engineer will promptly review the subsurface or physical condition in question; determine the necessity of Owner's obtaining additional exploration or tests with respect to the condition; conclude whether the condition falls within any one or more of the differing site condition categories in Paragraph 5.04.A above; obtain any pertinent cost or schedule information from Contractor; prepare recommendations to Owner regarding the Contractor's resumption of Work in connection with the subsurface or physical condition in question and the need for any change in the Drawings or Specifications; and advise Owner in writing of Engineer's findings, conclusions, and recommendations.
- C. *Owner's Statement to Contractor Regarding Site Condition:* After receipt of Engineer's written findings, conclusions, and recommendations, Owner shall issue a written statement to Contractor (with a copy to Engineer) regarding the subsurface or physical condition in question, addressing the resumption of Work in connection with such condition, indicating whether any change in the Drawings or Specifications will be made, and adopting or rejecting Engineer's written findings, conclusions, and recommendations, in whole or in part.
- D. *Possible Price and Times Adjustments:*
1. Contractor shall be entitled to an equitable adjustment in Contract Price or Contract Times, or both, to the extent that the existence of a differing subsurface or physical condition, or any related delay, disruption, or interference, causes an increase or decrease in Contractor's cost of, or time required for, performance of the Work; subject, however, to the following:
 - a. such condition must fall within any one or more of the categories described in Paragraph 5.04.A;
 - b. with respect to Work that is paid for on a unit price basis, any adjustment in Contract Price will be subject to the provisions of Paragraph 13.03; and,
 - c. Contractor's entitlement to an adjustment of the Contract Times is conditioned on such adjustment being essential to Contractor's ability to complete the Work within the Contract Times.
 2. Contractor shall not be entitled to any adjustment in the Contract Price or Contract Times with respect to a subsurface or physical condition if:
 - a. Contractor knew of the existence of such condition at the time Contractor made a commitment to Owner with respect to Contract Price and Contract Times by the submission of a Bid or becoming bound under a negotiated contract, or otherwise; or
 - b. the existence of such condition reasonably could have been discovered or revealed as a result of any examination, investigation, exploration, test, or

study of the Site and contiguous areas expressly required by the Bidding Requirements or Contract Documents to be conducted by or for Contractor prior to Contractor's making such commitment; or

- c. Contractor failed to give the written notice as required by Paragraph 5.04.A.
- 3. If Owner and Contractor agree regarding Contractor's entitlement to and the amount or extent of any adjustment in the Contract Price or Contract Times, or both, then any such adjustment shall be set forth in a Change Order.
- 4. Contractor may submit a Change Proposal regarding its entitlement to or the amount or extent of any adjustment in the Contract Price or Contract Times, or both, no later than 30 days after Owner's issuance of the Owner's written statement to Contractor regarding the subsurface or physical condition in question.

5.05 *Underground Facilities*

- A. *Contractor's Responsibilities:* The information and data shown or indicated in the Contract Documents with respect to existing Underground Facilities at or adjacent to the Site is based on information and data furnished to Owner or Engineer by the owners of such Underground Facilities, including Owner, or by others. Unless it is otherwise expressly provided in the Supplementary Conditions:
 - 1. Owner and Engineer do not warrant or guarantee the accuracy or completeness of any such information or data provided by others; and
 - 2. the cost of all of the following will be included in the Contract Price, and Contractor shall have full responsibility for:
 - a. reviewing and checking all information and data regarding existing Underground Facilities at the Site;
 - b. locating all Underground Facilities shown or indicated in the Contract Documents as being at the Site;
 - c. coordination of the Work with the owners (including Owner) of such Underground Facilities, during construction; and
 - d. the safety and protection of all existing Underground Facilities at the Site, and repairing any damage thereto resulting from the Work.
- B. *Notice by Contractor:* If Contractor believes that an Underground Facility that is uncovered or revealed at the Site was not shown or indicated in the Contract Documents, or was not shown or indicated with reasonable accuracy, then Contractor shall, promptly after becoming aware thereof and before further disturbing conditions affected thereby or performing any Work in connection therewith (except in an emergency as required by Paragraph 7.15), identify the owner of such Underground Facility and give written notice to that owner and to Owner and Engineer.
- C. *Engineer's Review:* Engineer will promptly review the Underground Facility and conclude whether such Underground Facility was not shown or indicated in the Contract Documents, or was not shown or indicated with reasonable accuracy; obtain any pertinent cost or schedule information from Contractor; prepare recommendations to Owner regarding the Contractor's resumption of Work in connection with the Underground Facility in question; determine the extent, if any, to which a change is

required in the Drawings or Specifications to reflect and document the consequences of the existence or location of the Underground Facility; and advise Owner in writing of Engineer's findings, conclusions, and recommendations. During such time, Contractor shall be responsible for the safety and protection of such Underground Facility.

D. *Owner's Statement to Contractor Regarding Underground Facility:* After receipt of Engineer's written findings, conclusions, and recommendations, Owner shall issue a written statement to Contractor (with a copy to Engineer) regarding the Underground Facility in question, addressing the resumption of Work in connection with such Underground Facility, indicating whether any change in the Drawings or Specifications will be made, and adopting or rejecting Engineer's written findings, conclusions, and recommendations in whole or in part.

E. *Possible Price and Times Adjustments:*

1. Contractor shall be entitled to an equitable adjustment in the Contract Price or Contract Times, or both, to the extent that any existing Underground Facility at the Site that was not shown or indicated in the Contract Documents, or was not shown or indicated with reasonable accuracy, or any related delay, disruption, or interference, causes an increase or decrease in Contractor's cost of, or time required for, performance of the Work; subject, however, to the following:

a. Contractor did not know of and could not reasonably have been expected to be aware of or to have anticipated the existence or actual location of the Underground Facility in question;

b. With respect to Work that is paid for on a unit price basis, any adjustment in Contract Price will be subject to the provisions of Paragraph 13.03;

c. Contractor's entitlement to an adjustment of the Contract Times is conditioned on such adjustment being essential to Contractor's ability to complete the Work within the Contract Times; and

d. Contractor gave the notice required in Paragraph 5.05.B.

2. If Owner and Contractor agree regarding Contractor's entitlement to and the amount or extent of any adjustment in the Contract Price or Contract Times, or both, then any such adjustment shall be set forth in a Change Order.

3. Contractor may submit a Change Proposal regarding its entitlement to or the amount or extent of any adjustment in the Contract Price or Contract Times, or both, no later than 30 days after Owner's issuance of the Owner's written statement to Contractor regarding the Underground Facility in question.

5.06 *Hazardous Environmental Conditions at Site*

A. *Reports and Drawings:* The Supplementary Conditions identify:

1. those reports and drawings known to Owner relating to Hazardous Environmental Conditions that have been identified at or adjacent to the Site; and

2. Technical Data contained in such reports and drawings.

B. *Reliance by Contractor on Technical Data Authorized:* Contractor may rely upon the accuracy of the Technical Data expressly identified in the Supplementary Conditions with respect to such reports and drawings, but such reports and drawings are not

Contract Documents. If no such express identification has been made, then Contractor may rely on the accuracy of the Technical Data (as defined in Article 1) contained in any geotechnical or environmental report prepared for the Project and made available to Contractor. Except for such reliance on Technical Data, Contractor may not rely upon or make any claim against Owner or Engineer, or any of their officers, directors, members, partners, employees, agents, consultants, or subcontractors with respect to:

1. the completeness of such reports and drawings for Contractor's purposes, including, but not limited to, any aspects of the means, methods, techniques, sequences and procedures of construction to be employed by Contractor and safety precautions and programs incident thereto; or
 2. other data, interpretations, opinions and information contained in such reports or shown or indicated in such drawings; or
 3. any Contractor interpretation of or conclusion drawn from any Technical Data or any such other data, interpretations, opinions or information.
- C. Contractor shall not be responsible for removing or remediating any Hazardous Environmental Condition encountered, uncovered, or revealed at the Site unless such removal or remediation is expressly identified in the Contract Documents to be within the scope of the Work.
- D. Contractor shall be responsible for controlling, containing, and duly removing all Constituents of Concern brought to the Site by Contractor, Subcontractors, Suppliers, or anyone else for whom Contractor is responsible, and for any associated costs; and for the costs of removing and remediating any Hazardous Environmental Condition created by the presence of any such Constituents of Concern.
- E. If Contractor encounters, uncovers, or reveals a Hazardous Environmental Condition whose removal or remediation is not expressly identified in the Contract Documents as being within the scope of the Work, or if Contractor or anyone for whom Contractor is responsible creates a Hazardous Environmental Condition, then Contractor shall immediately: (1) secure or otherwise isolate such condition; (2) stop all Work in connection with such condition and in any area affected thereby (except in an emergency as required by Paragraph 7.15); and (3) notify Owner and Engineer (and promptly thereafter confirm such notice in writing). Owner shall promptly consult with Engineer concerning the necessity for Owner to retain a qualified expert to evaluate such condition or take corrective action, if any. Promptly after consulting with Engineer, Owner shall take such actions as are necessary to permit Owner to timely obtain required permits and provide Contractor the written notice required by Paragraph 5.06.F. If Contractor or anyone for whom Contractor is responsible created the Hazardous Environmental Condition in question, then Owner may remove and remediate the Hazardous Environmental Condition, and impose a set-off against payments to account for the associated costs.
- F. Contractor shall not resume Work in connection with such Hazardous Environmental Condition or in any affected area until after Owner has obtained any required permits related thereto, and delivered written notice to Contractor either (1) specifying that such condition and any affected area is or has been rendered safe for the resumption of Work, or (2) specifying any special conditions under which such Work may be resumed safely.

- G. If Owner and Contractor cannot agree as to entitlement to or on the amount or extent, if any, of any adjustment in Contract Price or Contract Times, or both, as a result of such Work stoppage or such special conditions under which Work is agreed to be resumed by Contractor, then within 30 days of Owner's written notice regarding the resumption of Work, Contractor may submit a Change Proposal, or Owner may impose a set-off.
- H. If after receipt of such written notice Contractor does not agree to resume such Work based on a reasonable belief it is unsafe, or does not agree to resume such Work under such special conditions, then Owner may order the portion of the Work that is in the area affected by such condition to be deleted from the Work, following the contractual change procedures in Article 11. Owner may have such deleted portion of the Work performed by Owner's own forces or others in accordance with Article 8.
- I. To the fullest extent permitted by Laws and Regulations, Owner shall indemnify and hold harmless Contractor, Subcontractors, and Engineer, and the officers, directors, members, partners, employees, agents, consultants, and subcontractors of each and any of them from and against all claims, costs, losses, and damages (including but not limited to all fees and charges of engineers, architects, attorneys, and other professionals and all court or arbitration or other dispute resolution costs) arising out of or relating to a Hazardous Environmental Condition, provided that such Hazardous Environmental Condition (1) was not shown or indicated in the Drawings, Specifications, or other Contract Documents, identified as Technical Data entitled to limited reliance pursuant to Paragraph 5.06.B, or identified in the Contract Documents to be included within the scope of the Work, and (2) was not created by Contractor or by anyone for whom Contractor is responsible. Nothing in this Paragraph 5.06.H shall obligate Owner to indemnify any individual or entity from and against the consequences of that individual's or entity's own negligence.
- J. To the fullest extent permitted by Laws and Regulations, Contractor shall indemnify and hold harmless Owner and Engineer, and the officers, directors, members, partners, employees, agents, consultants, and subcontractors of each and any of them from and against all claims, costs, losses, and damages (including but not limited to all fees and charges of engineers, architects, attorneys, and other professionals and all court or arbitration or other dispute resolution costs) arising out of or relating to the failure to control, contain, or remove a Constituent of Concern brought to the Site by Contractor or by anyone for whom Contractor is responsible, or to a Hazardous Environmental Condition created by Contractor or by anyone for whom Contractor is responsible. Nothing in this Paragraph 5.06.J shall obligate Contractor to indemnify any individual or entity from and against the consequences of that individual's or entity's own negligence.
- K. The provisions of Paragraphs 5.03, 5.04, and 5.05 do not apply to the presence of Constituents of Concern or to a Hazardous Environmental Condition uncovered or revealed at the Site.

ARTICLE 6 – BONDS AND INSURANCE (Also see Instructions to Bidders)

6.01 *Performance, Payment, and Other Bonds*

- A. Contractor shall furnish a performance bond and a payment bond, each in an amount at least equal to the Contract Price, as security for the faithful performance and

payment of all of Contractor's obligations under the Contract. These bonds shall remain in effect until one year after the date when final payment becomes due or until completion of the correction period specified in Paragraph 15.08, whichever is later, except as provided otherwise by Laws or Regulations, the Supplementary Conditions, or other specific provisions of the Contract. Contractor shall also furnish such other bonds as are required by the Supplementary Conditions or other specific provisions of the Contract.

- B. All bonds shall be in the form prescribed by the Contract except as provided otherwise by Laws or Regulations, and shall be executed by such sureties as are named in "Companies Holding Certificates of Authority as Acceptable Sureties on Federal Bonds and as Acceptable Reinsuring Companies" as published in Circular 570 (as amended and supplemented) by the Financial Management Service, Surety Bond Branch, U.S. Department of the Treasury. A bond signed by an agent or attorney-in-fact must be accompanied by a certified copy of that individual's authority to bind the surety. The evidence of authority shall show that it is effective on the date the agent or attorney-in-fact signed the accompanying bond.
- C. Contractor shall obtain the required bonds from surety companies that are duly licensed or authorized in the jurisdiction in which the Project is located to issue bonds in the required amounts.
- D. If the surety on a bond furnished by Contractor is declared bankrupt or becomes insolvent, or its right to do business is terminated in any state or jurisdiction where any part of the Project is located, or the surety ceases to meet the requirements above, then Contractor shall promptly notify Owner and Engineer and shall, within 20 days after the event giving rise to such notification, provide another bond and surety, both of which shall comply with the bond and surety requirements above.
- E. If Contractor has failed to obtain a required bond, Owner may exclude the Contractor from the Site and exercise Owner's termination rights under Article 16.
- F. Upon request, Owner shall provide a copy of the payment bond to any Subcontractor, Supplier, or other person or entity claiming to have furnished labor or materials used in the performance of the Work.

6.02 *Insurance—General Provisions*

- A. Owner and Contractor shall obtain and maintain insurance as required in this Article and in the Supplementary Conditions.
- B. All insurance required by the Contract to be purchased and maintained by Owner or Contractor shall be obtained from insurance companies that are duly licensed or authorized, in the state or jurisdiction in which the Project is located, to issue insurance policies for the required limits and coverages. Unless a different standard is indicated in the Supplementary Conditions, all companies that provide insurance policies required under this Contract shall have an A.M. Best rating of A-VII or better.
- C. Contractor shall deliver to Owner, with copies to each named insured and additional insured (as identified in this Article, in the Supplementary Conditions, or elsewhere in the Contract), certificates of insurance establishing that Contractor has obtained and is maintaining the policies, coverages, and endorsements required by the Contract. Upon request by Owner or any other insured, Contractor shall also furnish other evidence of such required insurance, including but not limited to copies of policies and

- endorsements, and documentation of applicable self-insured retentions and deductibles. Contractor may block out (redact) any confidential premium or pricing information contained in any policy or endorsement furnished under this provision.
- D. Owner shall deliver to Contractor, with copies to each named insured and additional insured (as identified in this Article, the Supplementary Conditions, or elsewhere in the Contract), certificates of insurance establishing that Owner has obtained and is maintaining the policies, coverages, and endorsements required of Owner by the Contract (if any). Upon request by Contractor or any other insured, Owner shall also provide other evidence of such required insurance (if any), including but not limited to copies of policies and endorsements, and documentation of applicable self-insured retentions and deductibles. Owner may block out (redact) any confidential premium or pricing information contained in any policy or endorsement furnished under this provision.
- E. Failure of Owner or Contractor to demand such certificates or other evidence of the other party's full compliance with these insurance requirements, or failure of Owner or Contractor to identify a deficiency in compliance from the evidence provided, shall not be construed as a waiver of the other party's obligation to obtain and maintain such insurance.
- F. If either party does not purchase or maintain all of the insurance required of such party by the Contract, such party shall notify the other party in writing of such failure to purchase prior to the start of the Work, or of such failure to maintain prior to any change in the required coverage.
- G. If Contractor has failed to obtain and maintain required insurance, Owner may exclude the Contractor from the Site, impose an appropriate set-off against payment, and exercise Owner's termination rights under Article 16.
- H. Without prejudice to any other right or remedy, if a party has failed to obtain required insurance, the other party may elect to obtain equivalent insurance to protect such other party's interests at the expense of the party who was required to provide such coverage, and the Contract Price shall be adjusted accordingly.
- I. Owner does not represent that insurance coverage and limits established in this Contract necessarily will be adequate to protect Contractor or Contractor's interests.
- J. The insurance and insurance limits required herein shall not be deemed as a limitation on Contractor's liability under the indemnities granted to Owner and other individuals and entities in the Contract.

6.03 Contractor's Insurance

- A. *Workers' Compensation*: Contractor shall purchase and maintain workers' compensation and employer's liability insurance for:
1. claims under workers' compensation, disability benefits, and other similar employee benefit acts.
 2. United States Longshoreman and Harbor Workers' Compensation Act and Jones Act coverage (if applicable).
 3. claims for damages because of bodily injury, occupational sickness or disease, or death of Contractor's employees. **(last portion deleted)**

4. Foreign voluntary worker compensation (if applicable).
- B. *Commercial General Liability—Claims Covered:* Contractor shall purchase and maintain commercial general liability insurance, covering all operations by or on behalf of Contractor, on an occurrence basis, against:
1. claims for damages because of bodily injury, sickness or disease, or death of any person other than Contractor's employees.
 2. claims for damages insured by reasonably available personal injury liability coverage.
 3. claims for damages, other than to the Work itself, because of injury to or destruction of tangible property wherever located, including loss of use resulting therefrom.
- C. *Commercial General Liability—Form and Content:* Contractor's commercial liability policy shall be written on a 1996 (or later) ISO commercial general liability form (occurrence form) and include the following coverages and endorsements:
1. Products and completed operations coverage:
 - a. Such insurance shall be maintained **until the end of the warranty (guarantee) period.**
 - b. Contractor shall furnish Owner and each other additional insured (as identified in the Supplementary Conditions or elsewhere in the Contract) evidence of continuation of such insurance **until the end of the warranty (guarantee) period.**
 2. Blanket contractual liability coverage, to the extent permitted by law, including but not limited to coverage of Contractor's contractual indemnity obligations in Paragraph 7.18.
 3. Broad form property damage coverage.
 4. Severability of interest.
 5. Underground, explosion, and collapse coverage.
 6. Personal injury coverage.
 7. Additional insured endorsements that include both ongoing operations and products and completed operations coverage through ISO Endorsements CG 20 10 10 01 and CG 20 37 10 01 (together); or CG 20 10 07 04 and CG 20 37 07 04 (together); or their equivalent.
 8. For design professional additional insureds, ISO Endorsement CG 20 32 07 04, "Additional Insured—Engineers, Architects or Surveyors Not Engaged by the Named Insured" or its equivalent.
- D. *Automobile liability:* Contractor shall purchase and maintain automobile liability insurance against claims for damages because of bodily injury or death of any person or property damage arising out of the ownership, maintenance, or use of any motor vehicle. The automobile liability policy shall be written on an occurrence basis.
- E. *Umbrella or excess liability:* Contractor shall purchase and maintain umbrella or excess liability insurance written over the underlying employer's liability, commercial

general liability, and automobile liability insurance described in the paragraphs above. Subject to industry-standard exclusions, the coverage afforded shall follow form as to each and every one of the underlying policies.

- F. *Contractor's pollution liability insurance:* Contractor shall purchase and maintain a policy covering third-party injury and property damage claims, including clean-up costs, as a result of pollution conditions arising from Contractor's operations and completed operations. This insurance shall be maintained for no less than three years after final completion.
- G. *Additional insureds:* The Contractor's commercial general liability, automobile liability, umbrella or excess, and pollution liability policies shall include and list as additional insureds Owner and Engineer, and any individuals or entities identified in the Supplementary Conditions; include coverage for the respective officers, directors, members, partners, employees, agents, consultants, and subcontractors of each and any of all such additional insureds; and the insurance afforded to these additional insureds shall provide primary coverage for all claims covered thereby (including as applicable those arising from both ongoing and completed operations) on a non-contributory basis. Contractor shall obtain all necessary endorsements to support these requirements.
- H. *Contractor's professional liability insurance:* If Contractor will provide or furnish professional services under this Contract, through a delegation of professional design services or otherwise, then Contractor shall be responsible for purchasing and maintaining applicable professional liability insurance. This insurance shall provide protection against claims arising out of performance of professional design or related services, and caused by a negligent error, omission, or act for which the insured party is legally liable. It shall be maintained throughout the duration of the Contract and for a minimum of **the end of the warranty (guarantee) period**. If such professional design services are performed by a Subcontractor, and not by Contractor itself, then the requirements of this paragraph may be satisfied through the purchasing and maintenance of such insurance by such Subcontractor.
- I. *General provisions:* The policies of insurance required by this Paragraph 6.03 shall:
1. include at least the specific coverages provided in this Article.
 2. be written for not less than the limits of liability provided in this Article and in the Supplementary Conditions, or required by Laws or Regulations, whichever is greater.
 3. contain a provision or endorsement that the coverage afforded will not be canceled, materially changed, or renewal refused until at least 10 days prior written notice has been given to Contractor. Within three days of receipt of any such written notice, Contractor shall provide a copy of the notice to Owner, Engineer, and each other insured under the policy.
 4. remain in effect at least until **the end of the warranty (guarantee) period** and at all times thereafter when Contractor may be correcting, removing, or replacing defective Work as a warranty or correction obligation, or otherwise, or returning to the Site to conduct other tasks arising from the Contract Documents.
 5. be appropriate for the Work being performed and provide protection from claims that may arise out of or result from Contractor's performance of the Work and

Contractor's other obligations under the Contract Documents, whether it is to be performed by Contractor, any Subcontractor or Supplier, or by anyone directly or indirectly employed by any of them to perform any of the Work, or by anyone for whose acts any of them may be liable.

- J. The coverage requirements for specific policies of insurance must be met by such policies, and not by reference to excess or umbrella insurance provided in other policies.

6.04 *Owner's Liability Insurance*

- A. In addition to the insurance required to be provided by Contractor under Paragraph 6.03, Owner, at Owner's option, may purchase and maintain at Owner's expense Owner's own liability insurance as will protect Owner against claims which may arise from operations under the Contract Documents.
- B. Owner's liability policies, if any, operate separately and independently from policies required to be provided by Contractor, and Contractor cannot rely upon Owner's liability policies for any of Contractor's obligations to the Owner, Engineer, or third parties.

6.05 *Property Insurance*

- A. *Builder's Risk:* Unless otherwise provided in the Supplementary Conditions, Contractor shall purchase and maintain builder's risk insurance upon the Work on a completed value basis, in the amount of the full insurable replacement cost thereof (subject to such deductible amounts as may be provided in the Supplementary Conditions or required by Laws and Regulations). This insurance shall:
1. include the Owner and Contractor as named insureds, and all Subcontractors, and any individuals or entities required by the Supplementary Conditions to be insured under such builder's risk policy, as insureds or named insureds. For purposes of the remainder of this Paragraph 6.05, Paragraphs 6.06 and 6.07, and any corresponding Supplementary Conditions, the parties required to be insured shall collectively be referred to as "insureds."
 2. be written on a builder's risk "all risk" policy form that shall at least include insurance for physical loss or damage to the Work, temporary buildings, falsework, and materials and equipment in transit, and shall insure against at least the following perils or causes of loss: fire; lightning; windstorm; riot; civil commotion; terrorism; vehicle impact; aircraft; smoke; theft; vandalism and malicious mischief; mechanical breakdown, boiler explosion, and artificially generated electric current; earthquake; volcanic activity, and other earth movement; flood; collapse; explosion; debris removal; demolition occasioned by enforcement of Laws and Regulations; water damage (other than that caused by flood); and such other perils or causes of loss as may be specifically required by the Supplementary Conditions. If insurance against mechanical breakdown, boiler explosion, and artificially generated electric current; earthquake; volcanic activity, and other earth movement; or flood, are not commercially available under builder's risk policies, by endorsement or otherwise, such insurance may be provided through other insurance policies acceptable to Owner and Contractor.
 3. cover, as insured property, at least the following: (a) the Work and all materials, supplies, machinery, apparatus, equipment, fixtures, and other property of a

similar nature that are to be incorporated into or used in the preparation, fabrication, construction, erection, or completion of the Work, including Owner-furnished or assigned property; (b) spare parts inventory required within the scope of the Contract; and (c) temporary works which are not intended to form part of the permanent constructed Work but which are intended to provide working access to the Site, or to the Work under construction, or which are intended to provide temporary support for the Work under construction, including scaffolding, form work, fences, shoring, falsework, and temporary structures.

4. cover expenses incurred in the repair or replacement of any insured property (including but not limited to fees and charges of engineers and architects).
 5. extend to cover damage or loss to insured property while in temporary storage at the Site or in a storage location outside the Site (but not including property stored at the premises of a manufacturer or Supplier).
 6. extend to cover damage or loss to insured property while in transit.
 7. allow for partial occupation or use of the Work by Owner, such that those portions of the Work that are not yet occupied or used by Owner shall remain covered by the builder's risk insurance.
 8. allow for the waiver of the insurer's subrogation rights, as set forth below.
 9. provide primary coverage for all losses and damages caused by the perils or causes of loss covered.
 10. not include a co-insurance clause.
 11. include an exception for ensuing losses from physical damage or loss with respect to any defective workmanship, design, or materials exclusions.
 12. include performance/hot testing and start-up.
 13. be maintained in effect, subject to the provisions herein regarding Substantial Completion and partial occupancy or use of the Work by Owner, until the Work is complete.
- B. *Notice of Cancellation or Change:* All the policies of insurance (and the certificates or other evidence thereof) required to be purchased and maintained in accordance with this Paragraph 6.05 shall contain a provision or endorsement that the coverage afforded will not be canceled or materially changed or renewal refused until at least 10 days prior written notice has been given to the purchasing policyholder. Within three days of receipt of any such written notice, the purchasing policyholder shall provide a copy of the notice to each other insured.
- C. *Deductibles:* The purchaser of any required builder's risk or property insurance shall pay for costs not covered because of the application of a policy deductible.
- D. *Partial Occupancy or Use by Owner:* If Owner will occupy or use a portion or portions of the Work prior to Substantial Completion of all the Work as provided in Paragraph 15.04, then Owner (directly, if it is the purchaser of the builder's risk policy, or through Contractor) will provide notice of such occupancy or use to the builder's risk insurer. The builder's risk insurance shall not be canceled or permitted to lapse on account of any such partial use or occupancy; rather, those portions of the Work that are occupied or used by Owner may come off the builder's risk policy, while those portions of the

Work not yet occupied or used by Owner shall remain covered by the builder's risk insurance.

- E. *Additional Insurance*: If Contractor elects to obtain other special insurance to be included in or supplement the builder's risk or property insurance policies provided under this Paragraph 6.05, it may do so at Contractor's expense.
- F. *Insurance of Other Property*: If the express insurance provisions of the Contract do not require or address the insurance of a property item or interest, such as tools, construction equipment, or other personal property owned by Contractor, a Subcontractor, or an employee of Contractor or a Subcontractor, then the entity or individual owning such property item **shall** be responsible for deciding whether to insure it, and if so in what amount.

6.06 *Waiver of Rights*

- A. All policies purchased in accordance with Paragraph 6.05, expressly including the builder's risk policy, shall contain provisions to the effect that in the event of payment of any loss or damage the insurers will have no rights of recovery against any insureds thereunder, or against Engineer or its consultants, or their officers, directors, members, partners, employees, agents, consultants, or subcontractors. Owner and Contractor waive all rights against each other and the respective officers, directors, members, partners, employees, agents, consultants, and subcontractors of each and any of them, for all losses and damages caused by, arising out of, or resulting from any of the perils or causes of loss covered by such policies and any other property insurance applicable to the Work; and, in addition, waive all such rights against Engineer, its consultants, all Subcontractors, all individuals or entities identified in the Supplementary Conditions as insureds, and the officers, directors, members, partners, employees, agents, consultants, and subcontractors of each and any of them, under such policies for losses and damages so caused. None of the above waivers shall extend to the rights that any party making such waiver may have to the proceeds of insurance held by Owner or Contractor as trustee or fiduciary, or otherwise payable under any policy so issued.
- B. Owner waives all rights against Contractor, Subcontractors, and Engineer, and the officers, directors, members, partners, employees, agents, consultants and subcontractors of each and any of them, for:
 - 1. loss due to business interruption, loss of use, or other consequential loss extending beyond direct physical loss or damage to Owner's property or the Work caused by, arising out of, or resulting from fire or other perils whether or not insured by Owner; and
 - 2. loss or damage to the completed Project or part thereof caused by, arising out of, or resulting from fire or other insured peril or cause of loss covered by any property insurance maintained on the completed Project or part thereof by Owner during partial occupancy or use pursuant to Paragraph 15.04, after Substantial Completion pursuant to Paragraph 15.03, or after final payment pursuant to Paragraph 15.06.
- C. Any insurance policy maintained by Owner covering any loss, damage or consequential loss referred to in Paragraph 6.06.B shall contain provisions to the effect that in the event of payment of any such loss, damage, or consequential loss, the

insurers will have no rights of recovery against Contractor, Subcontractors, or Engineer, or the officers, directors, members, partners, employees, agents, consultants, or subcontractors of each and any of them.

- D. Contractor shall be responsible for assuring that the agreement under which a Subcontractor performs a portion of the Work contains provisions whereby the Subcontractor waives all rights against Owner, Contractor, all individuals or entities identified in the Supplementary Conditions as insureds, the Engineer and its consultants, and the officers, directors, members, partners, employees, agents, consultants, and subcontractors of each and any of them, for all losses and damages caused by, arising out of, relating to, or resulting from any of the perils or causes of loss covered by builder's risk insurance and any other property insurance applicable to the Work.

6.07 *Receipt and Application of Property Insurance Proceeds*

- A. Any insured loss under the builder's risk and other policies of insurance required by Paragraph 6.05 will be adjusted and settled with the named insured that purchased the policy. Such named insured shall act as fiduciary for the other insureds, and give notice to such other insureds that adjustment and settlement of a claim is in progress. Any other insured may state its position regarding a claim for insured loss in writing within 15 days after notice of such claim.
- B. Proceeds for such insured losses may be made payable by the insurer either jointly to multiple insureds, or to the named insured that purchased the policy in its own right and as fiduciary for other insureds, subject to the requirements of any applicable mortgage clause. A named insured receiving insurance proceeds under the builder's risk and other policies of insurance required by Paragraph 6.05 shall distribute such proceeds in accordance with such agreement as the parties in interest may reach, or as otherwise required under the dispute resolution provisions of this Contract or applicable Laws and Regulations.
- C. If no other special agreement is reached, the damaged Work shall be repaired or replaced, the money so received applied on account thereof, and the Work and the cost thereof covered by Change Order, if needed.

ARTICLE 7 – CONTRACTOR'S RESPONSIBILITIES

7.01 *Supervision and Superintendence*

- A. Contractor shall supervise, inspect, and direct the Work competently and efficiently, devoting such attention thereto and applying such skills and expertise as may be necessary to perform the Work in accordance with the Contract Documents. Contractor shall be solely responsible for the means, methods, techniques, sequences, and procedures of construction.
- B. At all times during the progress of the Work, Contractor shall assign a competent resident superintendent who shall not be replaced without written notice to Owner and Engineer except under extraordinary circumstances.

7.02 *Labor; Working Hours*

- A. Contractor shall provide competent, suitably qualified personnel to survey and lay out the Work and perform construction as required by the Contract Documents. Contractor shall at all times maintain good discipline and order at the Site.
- B. **This item intentionally deleted.**

7.03 *Services, Materials, and Equipment*

- A. Unless otherwise specified in the Contract Documents, Contractor shall provide and assume full responsibility for all services, materials, equipment, labor, transportation, construction equipment and machinery, tools, appliances, fuel, power, light, heat, telephone, water, sanitary facilities, temporary facilities, and all other facilities and incidentals necessary for the performance, testing, start up, and completion of the Work, whether or not such items are specifically called for in the Contract Documents.
- B. All materials and equipment incorporated into the Work shall be of good quality and new, except as otherwise provided in the Contract Documents. All special warranties and guarantees required by the Specifications shall expressly run to the benefit of Owner. If required by Engineer, Contractor shall furnish satisfactory evidence (including reports of required tests) as to the source, kind, and quality of materials and equipment.
- C. All materials and equipment shall be stored, applied, installed, connected, erected, protected, used, cleaned, and conditioned in accordance with instructions of the applicable Supplier, except as otherwise may be provided in the Contract Documents.

7.04 *"Or Equals"*

- A. Whenever an item of material or equipment is specified or described in the Contract Documents by using the name of a proprietary item or the name of a particular Supplier, the Contract Price has been based upon Contractor furnishing such item as specified. The specification or description of such an item is intended to establish the type, function, appearance, and quality required. Unless the specification or description contains or is followed by words reading that no like, equivalent, or "or equal" item is permitted, Contractor may request that Engineer authorize the use of other items of material or equipment, or items from other proposed suppliers under the circumstances described below.
 - 1. If Engineer in its sole discretion determines that an item of material or equipment proposed by Contractor is functionally equal to that named and sufficiently similar so that no change in related Work will be required, Engineer shall deem it an "or equal" item. For the purposes of this paragraph, a proposed item of material or equipment will be considered functionally equal to an item so named if:
 - a. in the exercise of reasonable judgment Engineer determines that:
 - 1) it is at least equal in materials of construction, quality, durability, appearance, strength, and design characteristics;
 - 2) it will reliably perform at least equally well the function and achieve the results imposed by the design concept of the completed Project as a functioning whole;

- 3) it has a proven record of performance and availability of responsive service; and
 - 4) it is not objectionable to Owner.
- b. Contractor certifies that, if approved and incorporated into the Work:
- 1) there will be no increase in cost to the Owner or increase in Contract Times; and
 - 2) it will conform substantially to the detailed requirements of the item named in the Contract Documents.
- B. *Contractor's Expense:* Contractor shall provide all data in support of any proposed "or equal" item at Contractor's expense.
- C. *Engineer's Evaluation and Determination:* Engineer will be allowed a reasonable time to evaluate each "or-equal" request. Engineer may require Contractor to furnish additional data about the proposed "or-equal" item. Engineer will be the sole judge of acceptability. No "or-equal" item will be ordered, furnished, installed, or utilized until Engineer's review is complete and Engineer determines that the proposed item is an "or-equal", which will be evidenced by an approved Shop Drawing or other written communication. Engineer will advise Contractor in writing of any negative determination.
- D. *Effect of Engineer's Determination:* Neither approval nor denial of an "or-equal" request shall result in any change in Contract Price. The Engineer's denial of an "or-equal" request shall be final and binding, and may not be reversed through an appeal under any provision of the Contract Documents.
- E. *Treatment as a Substitution Request:* If Engineer determines that an item of material or equipment proposed by Contractor does not qualify as an "or-equal" item, Contractor may request that Engineer considered the proposed item as a substitute pursuant to Paragraph 7.05.

7.05 *Substitutes*

- A. Unless the specification or description of an item of material or equipment required to be furnished under the Contract Documents contains or is followed by words reading that no substitution is permitted, Contractor may request that Engineer authorize the use of other items of material or equipment under the circumstances described below. To the extent possible such requests shall be made before commencement of related construction at the Site.
1. Contractor shall submit sufficient information as provided below to allow Engineer to determine if the item of material or equipment proposed is functionally equivalent to that named and an acceptable substitute therefor. Engineer will not accept requests for review of proposed substitute items of material or equipment from anyone other than Contractor.
 2. The requirements for review by Engineer will be as set forth in Paragraph 7.05.B, as supplemented by the Specifications, and as Engineer may decide is appropriate under the circumstances.

3. Contractor shall make written application to Engineer for review of a proposed substitute item of material or equipment that Contractor seeks to furnish or use. The application:
 - a. shall certify that the proposed substitute item will:
 - 1) perform adequately the functions and achieve the results called for by the general design,
 - 2) be similar in substance to that specified, and
 - 3) be suited to the same use as that specified.
 - b. will state:
 - 1) the extent, if any, to which the use of the proposed substitute item will necessitate a change in Contract Times,
 - 2) whether use of the proposed substitute item in the Work will require a change in any of the Contract Documents (or in the provisions of any other direct contract with Owner for other work on the Project) to adapt the design to the proposed substitute item, and
 - 3) whether incorporation or use of the proposed substitute item in connection with the Work is subject to payment of any license fee or royalty.
 - c. will identify:
 - 1) all variations of the proposed substitute item from that specified, and
 - 2) available engineering, sales, maintenance, repair, and replacement services.
 - d. shall contain an itemized estimate of all costs or credits that will result directly or indirectly from use of such substitute item, including but not limited to changes in Contract Price, shared savings, costs of redesign, and claims of other contractors affected by any resulting change.
- B. *Engineer's Evaluation and Determination*: Engineer will be allowed a reasonable time to evaluate each substitute request, and to obtain comments and direction from Owner. Engineer may require Contractor to furnish additional data about the proposed substitute item. Engineer will be the sole judge of acceptability. No substitute shall be ordered, furnished, installed, or utilized until Engineer's review is complete and Engineer determines that the proposed item is an acceptable substitute. Engineer's determination will be evidenced by a Field Order or a proposed Change Order accounting for the substitution itself and all related impacts, including changes in Contract Price or Contract Times. Engineer will advise Contractor in writing of any negative determination.
- C. *Special Guarantee*: Owner may require Contractor to furnish at Contractor's expense a special performance guarantee or other surety with respect to any substitute.
- D. *Reimbursement of Engineer's Cost*: Engineer will record Engineer's costs in evaluating a substitute proposed or submitted by Contractor. Whether or not Engineer approves a substitute so proposed or submitted by Contractor, Contractor shall reimburse Owner for the reasonable charges of Engineer for evaluating each such

proposed substitute. Contractor shall also reimburse Owner for the reasonable charges of Engineer for making changes in the Contract Documents (or in the provisions of any other direct contract with Owner) resulting from the acceptance of each proposed substitute.

- E. *Contractor's Expense:* Contractor shall provide all data in support of any proposed substitute at Contractor's expense.
- F. *Effect of Engineer's Determination:* If Engineer approves the substitution request, Contractor shall execute the proposed Change Order and proceed with the substitution. The Engineer's denial of a substitution request shall be final and binding, and may not be reversed through an appeal under any provision of the Contract Documents. Contractor may challenge the scope of reimbursement costs imposed under Paragraph 7.05.D, by timely submittal of a Change Proposal.

7.06 Concerning Subcontractors, Suppliers, and Others(Also see Specifications Section 1)

(The wording from the 2007 Edition is retained with Paragraph "O" (2013 Edition) added and relabeled "H".)

- A. **Contractor shall not employ any Subcontractor, Supplier, or other individual or entity (including those acceptable to Owner as indicated in Paragraph 7.06 B), whether initially or as a replacement, against whom Owner may have reasonable objection. Contractor shall not be required to employ any Subcontractor, Supplier, or other individual or entity to furnish or perform any of the Work against whom Contractor has reasonable objection.**
- B. **If Section 1 of the Specifications requires the identity of certain Subcontractors, Suppliers, or other individuals or entities to be submitted to Owner in advance for acceptance by Owner by a specified date prior to the Effective Date of the Agreement, and if Contractor has submitted a list thereof in accordance with Section 1 of the Specifications, Owner's acceptance (either in writing or by failing to make written objection thereto by the date indicated for acceptance or objection in the Bidding Documents or the Contract Documents) of any such Subcontractor, Supplier, or other individual or entity so identified may be revoked on the basis of reasonable objection after due investigation. Contractor shall submit an acceptable replacement for the rejected Subcontractor, Supplier, or other individual or entity, and the Contract Price will be adjusted by the difference in the cost occasioned by such replacement, and an appropriate Change Order will be issued. Acceptance by Owner of any such Subcontractor, Supplier, or other individual or entity, whether initially or as a replacement, shall not constitute a waiver of any right of Owner or Engineer to reject defective Work.**
- C. **Contractor shall be fully responsible to Owner and Engineer for all acts and omissions of the Subcontractors, Suppliers, and other individuals or entities performing or furnishing any of the Work just as Contractor is responsible for Contractor's own acts and omissions. Nothing in the Contract Documents:**
 - 1. **shall create for the benefit of any such Subcontractor, Supplier, or other individual or entity any contractual relationship between Owner or Engineer and any such Subcontractor, Supplier, or other individual or entity, nor**
 - 2. **shall create any obligation on the part of Owner or Engineer to pay or to see to the payment of any moneys due any such Subcontractor, Supplier, or other individual or entity except as may otherwise be required by Laws and Regulations.**
- D. **Contractor shall be solely responsible for scheduling and coordinating the Work of Subcontractors, Suppliers, and other individuals or entities performing or furnishing any of the work under a direct or indirect contract with Contractor.**

- E. Contractor shall require all Subcontractors, Suppliers, and such other individuals or entities performing or furnishing any of the Work to communicate with Engineer through Contractor.
- F. The divisions and sections of the Specifications and the identifications of any Drawings shall not control Contractor in dividing the Work among Subcontractors or Suppliers or delineating the Work to be performed by any specific trade.
- G. All Work performed for Contractor by a Subcontractor or Supplier will be pursuant to an appropriate agreement between Contractor and the Subcontractor or Supplier which specifically binds the Subcontractor or Supplier to the applicable terms and conditions of the Contract Documents for the benefit of Owner and Engineer. Whenever any such agreement is with a Subcontractor or Supplier who is listed as a loss payer on the property insurance provided in Paragraph 6.05, the agreement between the Contractor and the Subcontractor or Supplier will contain provisions whereby the Subcontractor or Supplier waives all rights against Owner, Contractor, Engineer, and all other individuals or entities identified in the Supplementary Conditions to be listed as insureds or loss payees (and the officers, directors, members, partners, employees, agents, consultants, and subcontractors of each and any of them) for all losses and damages caused by, arising out of, relating to, or resulting from any of the perils or causes of loss covered by such policies and any other property insurance applicable to the Work. If the insurers on any such policies require separate waiver forms to be signed by any Subcontractor or Suppliers, Contractor will obtain the same.
- H. Nothing in the Contract Documents:
 - 1. shall create for the benefit of any such Subcontractor, Supplier, or other individual or entity any contractual relationship between Owner or Engineer and any such Subcontractor, Supplier, or other individual or entity; nor
 - 2. shall create any obligation on the part of Owner or Engineer to pay or to see to the payment of any money due any such Subcontractor, Supplier, or other individual or entity except as may otherwise be required by Laws and Regulations.

7.07 *Patent Fees and Royalties*

- A. Contractor shall pay all license fees and royalties and assume all costs incident to the use in the performance of the Work or the incorporation in the Work of any invention, design, process, product, or device which is the subject of patent rights or copyrights held by others. If a particular invention, design, process, product, or device is specified in the Contract Documents for use in the performance of the Work and if, to the actual knowledge of Owner or Engineer, its use is subject to patent rights or copyrights calling for the payment of any license fee or royalty to others, the existence of such rights shall be disclosed by Owner in the Contract Documents.
- B. To the fullest extent permitted by Laws and Regulations, Owner shall indemnify and hold harmless Contractor, and its officers, directors, members, partners, employees, agents, consultants, and subcontractors from and against all claims, costs, losses, and damages (including but not limited to all fees and charges of engineers, architects, attorneys, and other professionals, and all court or arbitration or other dispute resolution costs) arising out of or relating to any infringement of patent rights or copyrights incident to the use in the performance of the Work or resulting from the incorporation in the Work of any invention, design, process, product, or device specified in the Contract Documents, but not identified as being subject to payment of any license fee or royalty to others required by patent rights or copyrights.

- C. To the fullest extent permitted by Laws and Regulations, Contractor shall indemnify and hold harmless Owner and Engineer, and the officers, directors, members, partners, employees, agents, consultants and subcontractors of each and any of them from and against all claims, costs, losses, and damages (including but not limited to all fees and charges of engineers, architects, attorneys, and other professionals and all court or arbitration or other dispute resolution costs) arising out of or relating to any infringement of patent rights or copyrights incident to the use in the performance of the Work or resulting from the incorporation in the Work of any invention, design, process, product, or device not specified in the Contract Documents.

7.08 *Permits*

- A. Unless otherwise provided in **Section 1 of the Specifications**, Contractor shall obtain and pay for all construction permits and licenses. Owner shall assist Contractor, when necessary, in obtaining such permits and licenses. Contractor shall pay all governmental charges and inspection fees necessary for the prosecution of the Work which are applicable at the time of the submission of Contractor's Bid (or when Contractor became bound under a negotiated contract). Owner shall pay all charges of utility owners for connections for providing permanent service to the Work

7.09 *Taxes*

- A. Contractor shall pay all sales, consumer, use, and other similar taxes required to be paid by Contractor in accordance with the Laws and Regulations of the place of the Project which are applicable during the performance of the Work.

7.10 *Laws and Regulations*

- A. Contractor shall give all notices required by and shall comply with all Laws and Regulations applicable to the performance of the Work. Except where otherwise expressly required by applicable Laws and Regulations, neither Owner nor Engineer shall be responsible for monitoring Contractor's compliance with any Laws or Regulations.
- B. If Contractor performs any Work or takes any other action knowing or having reason to know that it is contrary to Laws or Regulations, Contractor shall bear all resulting costs and losses, and shall indemnify and hold harmless Owner and Engineer, and the officers, directors, members, partners, employees, agents, consultants, and subcontractors of each and any of them from and against all claims, costs, losses, and damages (including but not limited to all fees and charges of engineers, architects, attorneys, and other professionals and all court or arbitration or other dispute resolution costs) arising out of or relating to such Work or other action. It shall not be Contractor's responsibility to make certain that the Work described in the Contract Documents is in accordance with Laws and Regulations, but this shall not relieve Contractor of Contractor's obligations under Paragraph 3.03.
- C. Owner or Contractor may give notice to the other party of any changes after the submission of Contractor's Bid (or after the date when Contractor became bound under a negotiated contract) in Laws or Regulations having an effect on the cost or time of performance of the Work, including but not limited to changes in Laws or Regulations having an effect on procuring permits and on sales, use, value-added, consumption, and other similar taxes. If Owner and Contractor are unable to agree on entitlement to or on the amount or extent, if any, of any adjustment in Contract Price or Contract

Times resulting from such changes, then within 30 days of such notice Contractor may submit a Change Proposal, or Owner may initiate a Claim.

7.11 *Record Documents*

- A. Contractor shall maintain in a safe place at the Site one printed record copy of all Drawings, Specifications, Addenda, Change Orders, Work Change Directives, Field Orders, written interpretations and clarifications, and approved Shop Drawings. Contractor shall keep such record documents in good order and annotate them to show changes made during construction. These record documents, together with all approved Samples, will be available to Engineer for reference. Upon completion of the Work, Contractor shall deliver these record documents to Engineer.

7.12 *Safety and Protection*

- A. Contractor shall be solely responsible for initiating, maintaining, and supervising all safety precautions and programs in connection with the Work. Such responsibility does not relieve Subcontractors of their responsibility for the safety of persons or property in the performance of their work, nor for compliance with applicable safety Laws and Regulations. Contractor shall take all necessary precautions for the safety of, and shall provide the necessary protection to prevent damage, injury, or loss to:
 - 1. all persons on the Site or who may be affected by the Work;
 - 2. all the Work and materials and equipment to be incorporated therein, whether in storage on or off the Site; and
 - 3. other property at the Site or adjacent thereto, including trees, shrubs, lawns, walks, pavements, roadways, structures, other work in progress, utilities, and Underground Facilities not designated for removal, relocation, or replacement in the course of construction.
- B. Contractor shall comply with all applicable Laws and Regulations relating to the safety of persons or property, or to the protection of persons or property from damage, injury, or loss; and shall erect and maintain all necessary safeguards for such safety and protection. Contractor shall notify Owner; the owners of adjacent property, Underground Facilities, and other utilities; and other contractors and utility owners performing work at or adjacent to the Site, when prosecution of the Work may affect them, and shall cooperate with them in the protection, removal, relocation, and replacement of their property or work in progress.
- C. Contractor shall comply with the applicable requirements of Owner's safety programs, if any. The Supplementary Conditions identify any Owner's safety programs that are applicable to the Work.
- D. Contractor shall inform Owner and Engineer of the specific requirements of Contractor's safety program with which Owner's and Engineer's employees and representatives must comply while at the Site.
- E. All damage, injury, or loss to any property referred to in Paragraph 7.12.A.2 or 7.12.A.3 caused, directly or indirectly, in whole or in part, by Contractor, any Subcontractor, Supplier, or any other individual or entity directly or indirectly employed by any of them to perform any of the Work, or anyone for whose acts any of them may be liable, shall be remedied by Contractor at its expense (except damage or loss attributable to the fault of Drawings or Specifications or to the acts or omissions

of Owner or Engineer or anyone employed by any of them, or anyone for whose acts any of them may be liable, and not attributable, directly or indirectly, in whole or in part, to the fault or negligence of Contractor or any Subcontractor, Supplier, or other individual or entity directly or indirectly employed by any of them).

- F. Contractor's duties and responsibilities for safety and protection shall continue until such time as all the Work is completed and Engineer has issued a notice to Owner and Contractor in accordance with Paragraph 15.06.B that the Work is acceptable (except as otherwise expressly provided in connection with Substantial Completion).
- G. Contractor's duties and responsibilities for safety and protection shall resume whenever Contractor or any Subcontractor or Supplier returns to the Site to fulfill warranty or correction obligations, or to conduct other tasks arising from the Contract Documents.

7.13 *Safety Representative*

- A. Contractor shall designate a qualified and experienced safety representative at the Site whose duties and responsibilities shall be the prevention of accidents and the maintaining and supervising of safety precautions and programs.

7.14 *Hazard Communication Programs*

- A. Contractor shall be responsible for coordinating any exchange of material safety data sheets or other hazard communication information required to be made available to or exchanged between or among employers at the Site in accordance with Laws or Regulations.

7.15 *Emergencies*

- A. In emergencies affecting the safety or protection of persons or the Work or property at the Site or adjacent thereto, Contractor is obligated to act to prevent threatened damage, injury, or loss. Contractor shall give Engineer prompt written notice if Contractor believes that any significant changes in the Work or variations from the Contract Documents have been caused thereby or are required as a result thereof. If Engineer determines that a change in the Contract Documents is required because of the action taken by Contractor in response to such an emergency, a Work Change Directive or Change Order will be issued.

7.16 *Shop Drawings, Samples, and Other Submittals*

A. *Shop Drawing and Sample Submittal Requirements:*

1. Before submitting a Shop Drawing or Sample, Contractor shall have:
 - a. reviewed and coordinated the Shop Drawing or Sample with other Shop Drawings and Samples and with the requirements of the Work and the Contract Documents;
 - b. determined and verified all field measurements, quantities, dimensions, specified performance and design criteria, installation requirements, materials, catalog numbers, and similar information with respect thereto;
 - c. determined and verified the suitability of all materials and equipment offered with respect to the indicated application, fabrication, shipping, handling, storage, assembly, and installation pertaining to the performance of the Work; and

- d. determined and verified all information relative to Contractor's responsibilities for means, methods, techniques, sequences, and procedures of construction, and safety precautions and programs incident thereto.
 2. Each submittal shall bear a stamp or specific written certification that Contractor has satisfied Contractor's obligations under the Contract Documents with respect to Contractor's review of that submittal, and that Contractor approves the submittal.
 3. With each submittal, Contractor shall give Engineer specific written notice of any variations that the Shop Drawing or Sample may have from the requirements of the Contract Documents. This notice shall be set forth in a written communication separate from the Shop Drawings or Sample submittal; and, in addition, in the case of Shop Drawings by a specific notation made on each Shop Drawing submitted to Engineer for review and approval of each such variation.
- B. *Submittal Procedures for Shop Drawings and Samples:* Contractor shall submit Shop Drawings and Samples to Engineer for review and approval in accordance with the accepted Schedule of Submittals. Each submittal will be identified as Engineer may require.
1. *Shop Drawings:*
 - a. Contractor shall submit the number of copies required in the Specifications.
 - b. Data shown on the Shop Drawings will be complete with respect to quantities, dimensions, specified performance and design criteria, materials, and similar data to show Engineer the services, materials, and equipment Contractor proposes to provide and to enable Engineer to review the information for the limited purposes required by Paragraph 7.16.D.
 2. *Samples:*
 - a. Contractor shall submit the number of Samples required in the Specifications.
 - b. Contractor shall clearly identify each Sample as to material, Supplier, pertinent data such as catalog numbers, the use for which intended and other data as Engineer may require to enable Engineer to review the submittal for the limited purposes required by Paragraph 7.16.D.
 3. Where a Shop Drawing or Sample is required by the Contract Documents or the Schedule of Submittals, any related Work performed prior to Engineer's review and approval of the pertinent submittal will be at the sole expense and responsibility of Contractor.
- C. *Other Submittals:* Contractor shall submit other submittals to Engineer in accordance with the accepted Schedule of Submittals, and pursuant to the applicable terms of the Specifications.
- D. *Engineer's Review:*
1. Engineer will provide timely review of Shop Drawings and Samples in accordance with the Schedule of Submittals acceptable to Engineer. Engineer's review and approval will be only to determine if the items covered by the submittals will, after installation or incorporation in the Work, conform to the information given in the Contract Documents and be compatible with the design

concept of the completed Project as a functioning whole as indicated by the Contract Documents.

2. Engineer's review and approval will not extend to means, methods, techniques, sequences, or procedures of construction or to safety precautions or programs incident thereto.
3. Engineer's review and approval of a separate item as such will not indicate approval of the assembly in which the item functions.
4. Engineer's review and approval of a Shop Drawing or Sample shall not relieve Contractor from responsibility for any variation from the requirements of the Contract Documents unless Contractor has complied with the requirements of Paragraph 7.16.A.3 and Engineer has given written approval of each such variation by specific written notation thereof incorporated in or accompanying the Shop Drawing or Sample. Engineer will document any such approved variation from the requirements of the Contract Documents in a Field Order.
5. Engineer's review and approval of a Shop Drawing or Sample shall not relieve Contractor from responsibility for complying with the requirements of Paragraph 7.16.A and B.
6. Engineer's review and approval of a Shop Drawing or Sample, or of a variation from the requirements of the Contract Documents, shall not, under any circumstances, change the Contract Times or Contract Price, unless such changes are included in a Change Order.
7. Neither Engineer's receipt, review, acceptance or approval of a Shop Drawing, Sample, or other submittal shall result in such item becoming a Contract Document.
8. Contractor shall perform the Work in compliance with the requirements and commitments set forth in approved Shop Drawings and Samples, subject to the provisions of Paragraph 7.16.D.4.

E. *Resubmittal Procedures:*

1. Contractor shall make corrections required by Engineer and shall return the required number of corrected copies of Shop Drawings and submit, as required, new Samples for review and approval. Contractor shall direct specific attention in writing to revisions other than the corrections called for by Engineer on previous submittals.
2. Contractor shall furnish required submittals with sufficient information and accuracy to obtain required approval of an item with no more than three submittals. Engineer will record Engineer's time for reviewing a fourth or subsequent submittal of a Shop Drawings, sample, or other item requiring approval, and Contractor shall be responsible for Engineer's charges to Owner for such time. Owner may impose a set-off against payments due to Contractor to secure reimbursement for such charges.
3. If Contractor requests a change of a previously approved submittal item, Contractor shall be responsible for Engineer's charges to Owner for its review time, and Owner may impose a set-off against payments due to Contractor to

secure reimbursement for such charges, unless the need for such change is beyond the control of Contractor.

7.17 *Contractor's General Warranty and Guarantee*

- A. Contractor warrants and guarantees to Owner that all Work will be in accordance with the Contract Documents and will not be defective. Engineer and its officers, directors, members, partners, employees, agents, consultants, and subcontractors shall be entitled to rely on Contractor's warranty and guarantee.
- B. Contractor's warranty and guarantee hereunder excludes defects or damage caused by:
 - 1. abuse, modification, or improper maintenance or operation by persons other than Contractor, Subcontractors, Suppliers, or any other individual or entity for whom Contractor is responsible; or
 - 2. normal wear and tear under normal usage.
- C. Contractor's obligation to perform and complete the Work in accordance with the Contract Documents shall be absolute. None of the following will constitute an acceptance of Work that is not in accordance with the Contract Documents or a release of Contractor's obligation to perform the Work in accordance with the Contract Documents:
 - 1. observations by Engineer;
 - 2. recommendation by Engineer or payment by Owner of any progress or final payment;
 - 3. the issuance of a certificate of Substantial Completion by Engineer or any payment related thereto by Owner;
 - 4. use or occupancy of the Work or any part thereof by Owner;
 - 5. any review and approval of a Shop Drawing or Sample submittal;
 - 6. the issuance of a notice of acceptability by Engineer;
 - 7. any inspection, test, or approval by others; or
 - 8. any correction of defective Work by Owner.
- D. If the Contract requires the Contractor to accept the assignment of a contract entered into by Owner, then the specific warranties, guarantees, and correction obligations contained in the assigned contract shall govern with respect to Contractor's performance obligations to Owner for the Work described in the assigned contract.

7.18 *Indemnification*

- A. To the fullest extent permitted by Laws and Regulations, and in addition to any other obligations of Contractor under the Contract or otherwise, Contractor shall indemnify and hold harmless Owner and Engineer, and the officers, directors, members, partners, employees, agents, consultants and subcontractors of each and any of them from and against all claims, costs, losses, and damages (including but not limited to all fees and charges of engineers, architects, attorneys, and other professionals and all court or arbitration or other dispute resolution costs) arising out of or relating to the performance of the Work, provided that any such claim, cost, loss, or damage is attributable to bodily injury, sickness, disease, or death, or to injury to or destruction

of tangible property (other than the Work itself), including the loss of use resulting therefrom but only to the extent caused by any negligent act or omission of Contractor, any Subcontractor, any Supplier, or any individual or entity directly or indirectly employed by any of them to perform any of the Work or anyone for whose acts any of them may be liable.

- B. In any and all claims against Owner or Engineer or any of their officers, directors, members, partners, employees, agents, consultants, or subcontractors by any employee (or the survivor or personal representative of such employee) of Contractor, any Subcontractor, any Supplier, or any individual or entity directly or indirectly employed by any of them to perform any of the Work, or anyone for whose acts any of them may be liable, the indemnification obligation under Paragraph 7.18.A shall not be limited in any way by any limitation on the amount or type of damages, compensation, or benefits payable by or for Contractor or any such Subcontractor, Supplier, or other individual or entity under workers' compensation acts, disability benefit acts, or other employee benefit acts.
- C. The indemnification obligations of Contractor under Paragraph 7.18.A shall not extend to the liability of Engineer and Engineer's officers, directors, members, partners, employees, agents, consultants and subcontractors arising out of:
 - 1. the preparation or approval of, or the failure to prepare or approve maps, Drawings, opinions, reports, surveys, Change Orders, designs, or Specifications; or
 - 2. giving directions or instructions, or failing to give them, if that is the primary cause of the injury or damage.

7.19 *Delegation of Professional Design Services*

- A. Contractor will not be required to provide professional design services unless such services are specifically required by the Contract Documents for a portion of the Work or unless such services are required to carry out Contractor's responsibilities for construction means, methods, techniques, sequences and procedures. Contractor shall not be required to provide professional services in violation of applicable Laws and Regulations.
- B. If professional design services or certifications by a design professional related to systems, materials, or equipment are specifically required of Contractor by the Contract Documents, Owner and Engineer will specify all performance and design criteria that such services must satisfy. Contractor shall cause such services or certifications to be provided by a properly licensed professional, whose signature and seal shall appear on all drawings, calculations, specifications, certifications, and other submittals prepared by such professional. Shop Drawings and other submittals related to the Work designed or certified by such professional, if prepared by others, shall bear such professional's written approval when submitted to Engineer.
- C. Owner and Engineer shall be entitled to rely upon the adequacy, accuracy, and completeness of the services, certifications, or approvals performed by such design professionals, provided Owner and Engineer have specified to Contractor all performance and design criteria that such services must satisfy.
- D. Pursuant to this paragraph, Engineer's review and approval of design calculations and design drawings will be only for the limited purpose of checking for conformance with

performance and design criteria given and the design concept expressed in the Contract Documents. Engineer's review and approval of Shop Drawings and other submittals (except design calculations and design drawings) will be only for the purpose stated in Paragraph 7.16.D.1.

- E. Contractor shall not be responsible for the adequacy of the performance or design criteria specified by Owner or Engineer.

ARTICLE 8 – OTHER WORK AT THE SITE

8.01 *Other Work*

- A. In addition to and apart from the Work under the Contract Documents, the Owner may perform other work at or adjacent to the Site. Such other work may be performed by Owner's employees, or through contracts between the Owner and third parties. Owner may also arrange to have third-party utility owners perform work on their utilities and facilities at or adjacent to the Site.
- B. If Owner performs other work at or adjacent to the Site with Owner's employees, or through contracts for such other work, then Owner shall give Contractor written notice thereof prior to starting any such other work. If Owner has advance information regarding the start of any utility work at or adjacent to the Site, Owner shall provide such information to Contractor.
- C. Contractor shall afford each other contractor that performs such other work, each utility owner performing other work, and Owner, if Owner is performing other work with Owner's employees, proper and safe access to the Site, and provide a reasonable opportunity for the introduction and storage of materials and equipment and the execution of such other work. Contractor shall do all cutting, fitting, and patching of the Work that may be required to properly connect or otherwise make its several parts come together and properly integrate with such other work. Contractor shall not endanger any work of others by cutting, excavating, or otherwise altering such work; provided, however, that Contractor may cut or alter others' work with the written consent of Engineer and the others whose work will be affected.
- D. If the proper execution or results of any part of Contractor's Work depends upon work performed by others under this Article 8, Contractor shall inspect such other work and promptly report to Engineer in writing any delays, defects, or deficiencies in such other work that render it unavailable or unsuitable for the proper execution and results of Contractor's Work. Contractor's failure to so report will constitute an acceptance of such other work as fit and proper for integration with Contractor's Work except for latent defects and deficiencies in such other work.

8.02 *Coordination*

- A. If Owner intends to contract with others for the performance of other work at or adjacent to the Site, to perform other work at or adjacent to the Site with Owner's employees, or to arrange to have utility owners perform work at or adjacent to the Site, the following will be set forth in the Supplementary Conditions, **Section 1 of the Specifications**, or provided to Contractor prior to the start of any such other work:
 - 1. the identity of the individual or entity that will have authority and responsibility for coordination of the activities among the various contractors;

2. an itemization of the specific matters to be covered by such authority and responsibility; and
 3. the extent of such authority and responsibilities.
- B. Unless otherwise provided in **Section 1 of the Specifications**, Owner shall have sole authority and responsibility for such coordination.

8.03 *Legal Relationships*

- A. If, in the course of performing other work at or adjacent to the Site for Owner, the Owner's employees, any other contractor working for Owner, or any utility owner causes damage to the Work or to the property of Contractor or its Subcontractors, or delays, disrupts, interferes with, or increases the scope or cost of the performance of the Work, through actions or inaction, then Contractor shall be entitled to an equitable adjustment in the Contract Price or the Contract Times, or both. Contractor must submit any Change Proposal seeking an equitable adjustment in the Contract Price or the Contract Times under this paragraph within 30 days of the damaging, delaying, disrupting, or interfering event. The entitlement to, and extent of, any such equitable adjustment shall take into account information (if any) regarding such other work that was provided to Contractor in the Contract Documents prior to the submittal of the Bid or the final negotiation of the terms of the Contract. When applicable, any such equitable adjustment in Contract Price shall be conditioned on Contractor assigning to Owner all Contractor's rights against such other contractor or utility owner with respect to the damage, delay, disruption, or interference that is the subject of the adjustment. Contractor's entitlement to an adjustment of the Contract Times is conditioned on such adjustment being essential to Contractor's ability to complete the Work within the Contract Times.
- B. Contractor shall take reasonable and customary measures to avoid damaging, delaying, disrupting, or interfering with the work of Owner, any other contractor, or any utility owner performing other work at or adjacent to the Site. If Contractor fails to take such measures and as a result damages, delays, disrupts, or interferes with the work of any such other contractor or utility owner, then Owner may impose a set-off against payments due to Contractor, and assign to such other contractor or utility owner the Owner's contractual rights against Contractor with respect to the breach of the obligations set forth in this paragraph.
- C. When Owner is performing other work at or adjacent to the Site with Owner's employees, Contractor shall be liable to Owner for damage to such other work, and for the reasonable direct delay, disruption, and interference costs incurred by Owner as a result of Contractor's failure to take reasonable and customary measures with respect to Owner's other work. In response to such damage, delay, disruption, or interference, Owner may impose a set-off against payments due to Contractor.
- D. If Contractor damages, delays, disrupts, or interferes with the work of any other contractor, or any utility owner performing other work at or adjacent to the Site, through Contractor's failure to take reasonable and customary measures to avoid such impacts, or if any claim arising out of Contractor's actions, inactions, or negligence in performance of the Work at or adjacent to the Site is made by any such other contractor or utility owner against Contractor, Owner, or Engineer, then Contractor shall (1) promptly attempt to settle the claim as to all parties through negotiations with such other contractor or utility owner, or otherwise resolve the claim by arbitration or other

dispute resolution proceeding or at law, and (2) indemnify and hold harmless Owner and Engineer, and the officers, directors, members, partners, employees, agents, consultants and subcontractors of each and any of them from and against any such claims, and against all costs, losses, and damages (including but not limited to all fees and charges of engineers, architects, attorneys, and other professionals and all court or arbitration or other dispute resolution costs) arising out of or relating to such damage, delay, disruption, or interference.

ARTICLE 9 – OWNER’S RESPONSIBILITIES

9.01 *Communications to Contractor*

- A. Except as otherwise provided in these General Conditions, Owner shall issue all communications to Contractor through Engineer.

9.02 *Replacement of Engineer*

- A. Owner may at its discretion appoint an engineer to replace Engineer, provided Contractor makes no reasonable objection to the replacement engineer. The replacement engineer’s status under the Contract Documents shall be that of the former Engineer.

9.03 *Furnish Data*

- A. Owner shall promptly furnish the data required of Owner under the Contract Documents.

9.04 *Pay When Due*

- A. Owner shall make payments to Contractor **in accordance with Paragraph 15.01 D.**

9.05 *Lands and Easements; Reports, Tests, and Drawings*

- A. Owner’s duties with respect to providing lands and easements are set forth in Paragraph 5.01.
- B. Owner’s duties with respect to providing engineering surveys to establish reference points are set forth in Paragraph 4.03.
- C. Article 5 refers to Owner’s identifying and making available to Contractor copies of reports of explorations and tests of conditions at the Site, and drawings of physical conditions relating to existing surface or subsurface structures at the Site.

9.06 *Insurance*

- A. Owner’s responsibilities, if any, with respect to purchasing and maintaining liability and property insurance are set forth in Article 6.

9.07 *Change Orders*

- A. Owner’s responsibilities with respect to Change Orders are set forth in Article 11.

9.08 *Inspections, Tests, and Approvals*

- A. Owner’s responsibility with respect to certain inspections, tests, and approvals is set forth in Paragraph 14.02.B.

9.09 *Limitations on Owner's Responsibilities*

- A. The Owner will not supervise, direct, or have control or authority over, nor be responsible for, Contractor's means, methods, techniques, sequences, or procedures of construction, or the safety precautions and programs incident thereto, or for any failure of Contractor to comply with Laws and Regulations applicable to the performance of the Work. Owner will not be responsible for Contractor's failure to perform the Work in accordance with the Contract Documents.

9.10 *Undisclosed Hazardous Environmental Condition*

- A. Owner's responsibility in respect to an undisclosed Hazardous Environmental Condition is set forth in Paragraph 5.06.

9.11 *Evidence of Financial Arrangements*

- A. Upon request of Contractor, Owner shall furnish Contractor reasonable evidence that financial arrangements have been made to satisfy Owner's obligations under the Contract Documents (including obligations under proposed changes in the Work).

9.12 *Safety Programs*

- A. While at the Site, Owner's employees and representatives shall comply with the specific applicable requirements of Contractor's safety programs of which Owner has been informed.
- B. Owner shall furnish copies of any applicable Owner safety programs to Contractor.

ARTICLE 10 – ENGINEER'S STATUS DURING CONSTRUCTION

10.01 *Owner's Representative*

- A. Engineer will be Owner's representative during the construction period. The duties and responsibilities and the limitations of authority of Engineer as Owner's representative during construction are set forth in the Contract.

10.02 *Visits to Site*

- A. Engineer will make visits to the Site at intervals appropriate to the various stages of construction as Engineer deems necessary in order to observe as an experienced and qualified design professional the progress that has been made and the quality of the various aspects of Contractor's executed Work. Based on information obtained during such visits and observations, Engineer, for the benefit of Owner, will determine, in general, if the Work is proceeding in accordance with the Contract Documents. Engineer will not be required to make exhaustive or continuous inspections on the Site to check the quality or quantity of the Work. Engineer's efforts will be directed toward providing for Owner a greater degree of confidence that the completed Work will conform generally to the Contract Documents. On the basis of such visits and observations, Engineer will keep Owner informed of the progress of the Work and will endeavor to guard Owner against defective Work.
- B. Engineer's visits and observations are subject to all the limitations on Engineer's authority and responsibility set forth in Paragraph 10.08. Particularly, but without limitation, during or as a result of Engineer's visits or observations of Contractor's Work, Engineer will not supervise, direct, control, or have authority over or be responsible for Contractor's means, methods, techniques, sequences, or procedures of

construction, or the safety precautions and programs incident thereto, or for any failure of Contractor to comply with Laws and Regulations applicable to the performance of the Work.

10.03 *Project Representative*

- A. If Owner and Engineer have agreed that Engineer will furnish a Resident Project Representative to represent Engineer at the Site and assist Engineer in observing the progress and quality of the Work, then the authority and responsibilities of any such Resident Project Representative will be as provided in the Supplementary Conditions, and limitations on the responsibilities thereof will be as provided in Paragraph 10.08. If Owner designates another representative or agent to represent Owner at the Site who is not Engineer's consultant, agent, or employee, the responsibilities and authority and limitations thereon of such other individual or entity will be as provided in the Supplementary Conditions.

10.04 *Rejecting Defective Work*

- A. Engineer has the authority to reject Work in accordance with Article 14.

10.05 *Shop Drawings, Change Orders and Payments*

- A. Engineer's authority, and limitations thereof, as to Shop Drawings and Samples, are set forth in Paragraph 7.16.
- B. Engineer's authority, and limitations thereof, as to design calculations and design drawings submitted in response to a delegation of professional design services, if any, are set forth in Paragraph 7.19.
- C. Engineer's authority as to Change Orders is set forth in Article 11.
- D. Engineer's authority as to Applications for Payment is set forth in Article 15.

10.06 *Determinations for Unit Price Work*

- A. Engineer will determine the actual quantities and classifications of Unit Price Work performed by Contractor as set forth in Paragraph 13.03.

10.07 *Decisions on Requirements of Contract Documents and Acceptability of Work*

- A. Engineer will render decisions regarding the requirements of the Contract Documents, and judge the acceptability of the Work, pursuant to the specific procedures set forth herein for initial interpretations, Change Proposals, and acceptance of the Work. In rendering such decisions and judgments, Engineer will not show partiality to Owner or Contractor, and will not be liable to Owner, Contractor, or others in connection with any proceedings, interpretations, decisions, or judgments conducted or rendered in good faith.

10.08 *Limitations on Engineer's Authority and Responsibilities*

- A. Neither Engineer's authority or responsibility under this Article 10 or under any other provision of the Contract, nor any decision made by Engineer in good faith either to exercise or not exercise such authority or responsibility or the undertaking, exercise, or performance of any authority or responsibility by Engineer, shall create, impose, or give rise to any duty in contract, tort, or otherwise owed by Engineer to Contractor, any Subcontractor, any Supplier, any other individual or entity, or to any surety for or employee or agent of any of them.

- B. Engineer will not supervise, direct, control, or have authority over or be responsible for Contractor's means, methods, techniques, sequences, or procedures of construction, or the safety precautions and programs incident thereto, or for any failure of Contractor to comply with Laws and Regulations applicable to the performance of the Work. Engineer will not be responsible for Contractor's failure to perform the Work in accordance with the Contract Documents.
- C. Engineer will not be responsible for the acts or omissions of Contractor or of any Subcontractor, any Supplier, or of any other individual or entity performing any of the Work.
- D. Engineer's review of the final Application for Payment and accompanying documentation and all maintenance and operating instructions, schedules, guarantees, bonds, certificates of inspection, tests and approvals, and other documentation required to be delivered by Paragraph 15.06.A will only be to determine generally that their content complies with the requirements of, and in the case of certificates of inspections, tests, and approvals, that the results certified indicate compliance with the Contract Documents.
- E. The limitations upon authority and responsibility set forth in this Paragraph 10.08 shall also apply to the Resident Project Representative, if any.

10.09 *Compliance with Safety Program*

- A. While at the Site, Engineer's employees and representatives **shall** comply with the specific applicable requirements of Owner's and Contractor's safety programs (if any) of which Engineer has been informed.

ARTICLE 11 – AMENDING THE CONTRACT DOCUMENTS; CHANGES IN THE WORK

11.01 *Amending and Supplementing Contract Documents*

- A. The Contract Documents may be amended or supplemented by a Change Order, a Work Change Directive, or a Field Order.
 - 1. *Change Orders:*
 - a. If an amendment or supplement to the Contract Documents includes a change in the Contract Price or the Contract Times, such amendment or supplement must be set forth in a Change Order. A Change Order also may be used to establish amendments and supplements of the Contract Documents that do not affect the Contract Price or Contract Times.
 - b. Owner and Contractor may amend those terms and conditions of the Contract Documents that do not involve (1) the performance or acceptability of the Work, (2) the design (as set forth in the Drawings, Specifications, or otherwise), or (3) other engineering or technical matters, without the recommendation of the Engineer. Such an amendment shall be set forth in a Change Order.
 - 2. *Work Change Directives:* A Work Change Directive will not change the Contract Price or the Contract Times but is evidence that the parties expect that the modification ordered or documented by a Work Change Directive will be incorporated in a subsequently issued Change Order, following negotiations by

the parties as to the Work Change Directive's effect, if any, on the Contract Price and Contract Times; or, if negotiations are unsuccessful, by a determination under the terms of the Contract Documents governing adjustments, expressly including Paragraph 11.04 regarding change of Contract Price. Contractor must submit any Change Proposal seeking an adjustment of the Contract Price or the Contract Times, or both, no later than 30 days after the completion of the Work set out in the Work Change Directive. Owner must submit any Claim seeking an adjustment of the Contract Price or the Contract Times, or both, no later than 60 days after issuance of the Work Change Directive.

3. *Field Orders*: Engineer may authorize minor changes in the Work if the changes do not involve an adjustment in the Contract Price or the Contract Times and are compatible with the design concept of the completed Project as a functioning whole as indicated by the Contract Documents. Such changes will be accomplished by a Field Order and will be binding on Owner and also on Contractor, which shall perform the Work involved promptly. If Contractor believes that a Field Order justifies an adjustment in the Contract Price or Contract Times, or both, then before proceeding with the Work at issue, Contractor shall submit a Change Proposal as provided herein.

11.02 *Owner-Authorized Changes in the Work*

- A. Without invalidating the Contract and without notice to any surety, Owner may, at any time or from time to time, order additions, deletions, or revisions in the Work. Such changes shall be supported by Engineer's recommendation, to the extent the change involves the design (as set forth in the Drawings, Specifications, or otherwise), or other engineering or technical matters. Such changes may be accomplished by a Change Order, if Owner and Contractor have agreed as to the effect, if any, of the changes on Contract Times or Contract Price; or by a Work Change Directive. Upon receipt of any such document, Contractor shall promptly proceed with the Work involved; or, in the case of a deletion in the Work, promptly cease construction activities with respect to such deleted Work. Added or revised Work shall be performed under the applicable conditions of the Contract Documents. Nothing in this paragraph shall obligate Contractor to undertake work that Contractor reasonably concludes cannot be performed in a manner consistent with Contractor's safety obligations under the Contract Documents or Laws and Regulations.

11.03 *Unauthorized Changes in the Work*

- A. Contractor shall not be entitled to an increase in the Contract Price or an extension of the Contract Times with respect to any work performed that is not required by the Contract Documents, as amended, modified, or supplemented, except in the case of an emergency as provided in Paragraph 7.15 or in the case of uncovering Work as provided in Paragraph 14.05.

11.04 *Change of Contract Price*

- A. The Contract Price may only be changed by a Change Order. Any Change Proposal for an adjustment in the Contract Price shall comply with the provisions of Paragraph 11.06. Any Claim for an adjustment of Contract Price shall comply with the provisions of Article 12.

- B. An adjustment in the Contract Price will be determined as follows:
1. where the Work involved is covered by unit prices contained in the Contract Documents, then by application of such unit prices to the quantities of the items involved (subject to the provisions of Paragraph 13.03); or
 2. where the Work involved is not covered by unit prices contained in the Contract Documents, then by a mutually agreed lump sum (which may include an allowance for overhead and profit not necessarily in accordance with Paragraph 11.04.C.2); or
 3. where the Work involved is not covered by unit prices contained in the Contract Documents and the parties do not reach mutual agreement to a lump sum, then on the basis of the Cost of the Work (determined as provided in Paragraph 13.01) plus a Contractor's fee for overhead and profit (determined as provided in Paragraph 11.04.C).
- C. *Contractor's Fee*: When applicable, the Contractor's fee for overhead and profit shall be determined as follows:
1. a mutually acceptable fixed fee; or
 2. if a fixed fee is not agreed upon, then a fee based on the following percentages of the various portions of the Cost of the Work:
 - a. for costs incurred under Paragraphs 13.01.B.1 and 13.01.B.2, the Contractor's fee shall be 15 percent;
 - b. for costs incurred under Paragraph 13.01.B.3, the Contractor's fee shall be five percent;
 - c. where one or more tiers of subcontracts are on the basis of Cost of the Work plus a fee and no fixed fee is agreed upon, the intent of Paragraphs 11.01.C.2.a and 11.01.C.2.b is that the Contractor's fee shall be based on: (1) a fee of 15 percent of the costs incurred under Paragraphs 13.01.A.1 and 13.01.A.2 by the Subcontractor that actually performs the Work, at whatever tier, and (2) with respect to Contractor itself and to any Subcontractors of a tier higher than that of the Subcontractor that actually performs the Work, a fee of five percent of the amount (fee plus underlying costs incurred) attributable to the next lower tier Subcontractor; provided, however, that for any such subcontracted work the maximum total fee to be paid by Owner shall be no greater than 27 percent of the costs incurred by the Subcontractor that actually performs the work;
 - d. no fee shall be payable on the basis of costs itemized under Paragraphs 13.01.B.4, 13.01.B.5, and 13.01.C;
 - e. the amount of credit to be allowed by Contractor to Owner for any change which results in a net decrease in cost will be the amount of the actual net decrease in cost plus a deduction in Contractor's fee by an amount equal to five percent of such net decrease; and
 - f. when both additions and credits are involved in any one change, the adjustment in Contractor's fee shall be computed on the basis of the net

change in accordance with Paragraphs 11.04.C.2.a through 11.04.C.2.e, inclusive.

11.05 *Change of Contract Times*

- A. The Contract Times may only be changed by a Change Order. Any Change Proposal for an adjustment in the Contract Times shall comply with the provisions of Paragraph 11.06. Any Claim for an adjustment in the Contract Times shall comply with the provisions of Article 12.
- B. An adjustment of the Contract Times shall be subject to the limitations set forth in Paragraph 4.05, concerning delays in Contractor's progress.

11.06 *Change Proposals*

- A. Contractor shall submit a Change Proposal to Engineer to request an adjustment in the Contract Times or Contract Price; appeal an initial decision by Engineer concerning the requirements of the Contract Documents or relating to the acceptability of the Work under the Contract Documents; contest a set-off against payment due; or seek other relief under the Contract. The Change Proposal shall specify any proposed change in Contract Times or Contract Price, or both, or other proposed relief, and explain the reason for the proposed change, with citations to any governing or applicable provisions of the Contract Documents.
 - 1. *Procedures*: Contractor shall submit each Change Proposal to Engineer promptly (but in no event later than 30 days) after the start of the event giving rise thereto, or after such initial decision. The Contractor shall submit supporting data, including the proposed change in Contract Price or Contract Time (if any), to the Engineer and Owner within 15 days after the submittal of the Change Proposal. The supporting data shall be accompanied by a written statement that the supporting data are accurate and complete, and that any requested time or price adjustment is the entire adjustment to which Contractor believes it is entitled as a result of said event. Engineer will advise Owner regarding the Change Proposal, and consider any comments or response from Owner regarding the Change Proposal.
 - 2. *Engineer's Action*: Engineer will review each Change Proposal and, within 30 days after receipt of the Contractor's supporting data, either deny the Change Proposal in whole, approve it in whole, or deny it in part and approve it in part. Such actions shall be in writing, with a copy provided to Owner and Contractor. If Engineer does not take action on the Change Proposal within 30 days, then either Owner or Contractor may at any time thereafter submit a letter to the other party indicating that as a result of Engineer's inaction the Change Proposal is deemed denied, thereby commencing the time for appeal of the denial under Article 12.
 - 3. *Binding Decision*: Engineer's decision will be final and binding upon Owner and Contractor, unless Owner or Contractor appeals the decision by filing a Claim under Article 12.
- B. *Resolution of Certain Change Proposals*: If the Change Proposal does not involve the design (as set forth in the Drawings, Specifications, or otherwise), the acceptability of the Work, or other engineering or technical matters, then Engineer will notify the parties that the Engineer is unable to resolve the Change Proposal. For purposes of

further resolution of such a Change Proposal, such notice shall be deemed a denial, and Contractor may choose to seek resolution under the terms of Article 12.

11.07 *Execution of Change Orders*

- A. Owner and Contractor shall execute appropriate Change Orders covering:
1. changes in the Contract Price or Contract Times which are agreed to by the parties, including any undisputed sum or amount of time for Work actually performed in accordance with a Work Change Directive;
 2. changes in Contract Price resulting from an Owner set-off, unless Contractor has duly contested such set-off;
 3. changes in the Work which are: (a) ordered by Owner pursuant to Paragraph 11.02, (b) required because of Owner's acceptance of defective Work under Paragraph 14.04 or Owner's correction of defective Work under Paragraph 14.07, or (c) agreed to by the parties, subject to the need for Engineer's recommendation if the change in the Work involves the design (as set forth in the Drawings, Specifications, or otherwise), or other engineering or technical matters; and
 4. changes in the Contract Price or Contract Times, or other changes, which embody the substance of any final and binding results under Paragraph 11.06, or Article 12.
- B. If Owner or Contractor refuses to execute a Change Order that is required to be executed under the terms of this Paragraph 11.07, it shall be deemed to be of full force and effect, as if fully executed.

11.08 *Notification to Surety*

- A. If the provisions of any bond require notice to be given to a surety of any change affecting the general scope of the Work or the provisions of the Contract Documents (including, but not limited to, Contract Price or Contract Times), the giving of any such notice will be Contractor's responsibility. The amount of each applicable bond will be adjusted to reflect the effect of any such change.

ARTICLE 12 – CLAIMS

12.01 *Claims*

- A. *Claims Process:* The following disputes between Owner and Contractor shall be submitted to the Claims process set forth in this Article:
1. Appeals by Owner or Contractor of Engineer's decisions regarding Change Proposals;
 2. Owner demands for adjustments in the Contract Price or Contract Times, or other relief under the Contract Documents; and
 3. Disputes that Engineer has been unable to address because they do not involve the design (as set forth in the Drawings, Specifications, or otherwise), the acceptability of the Work, or other engineering or technical matters.
- B. *Submittal of Claim:* The party submitting a Claim shall deliver it directly to the other party to the Contract promptly (but in no event later than 30 days) after the start of the event giving rise thereto; in the case of appeals regarding Change Proposals within 30

days of the decision under appeal. The party submitting the Claim shall also furnish a copy to the Engineer, for its information only. The responsibility to substantiate a Claim shall rest with the party making the Claim. In the case of a Claim by Contractor seeking an increase in the Contract Times or Contract Price, or both, Contractor shall certify that the Claim is made in good faith, that the supporting data are accurate and complete, and that to the best of Contractor's knowledge and belief the amount of time or money requested accurately reflects the full amount to which Contractor is entitled.

- C. *Review and Resolution:* The party receiving a Claim shall review it thoroughly, giving full consideration to its merits. The two parties shall seek to resolve the Claim through the exchange of information and direct negotiations. The parties may extend the time for resolving the Claim by mutual agreement. All actions taken on a Claim shall be stated in writing and submitted to the other party, with a copy to Engineer.
- D. *Mediation:*
1. At any time after initiation of a Claim, Owner and Contractor may mutually agree to mediation of the underlying dispute. The agreement to mediate shall stay the Claim submittal and response process.
 2. If Owner and Contractor agree to mediation, then after 60 days from such agreement, either Owner or Contractor may unilaterally terminate the mediation process, and the Claim submittal and decision process shall resume as of the date of the termination. If the mediation proceeds but is unsuccessful in resolving the dispute, the Claim submittal and decision process shall resume as of the date of the conclusion of the mediation, as determined by the mediator.
 3. Owner and Contractor shall each pay one-half of the mediator's fees and costs.
- E. *Partial Approval:* If the party receiving a Claim approves the Claim in part and denies it in part, such action shall be final and binding unless within 30 days of such action the other party invokes the procedure set forth in Article 17 for final resolution of disputes.
- F. *Denial of Claim:* If efforts to resolve a Claim are not successful, the party receiving the Claim may deny it by giving written notice of denial to the other party. If the receiving party does not take action on the Claim within 90 days, then either Owner or Contractor may at any time thereafter submit a letter to the other party indicating that as a result of the inaction, the Claim is deemed denied, thereby commencing the time for appeal of the denial. A denial of the Claim shall be final and binding unless within 30 days of the denial the other party invokes the procedure set forth in Article 17 for the final resolution of disputes.
- G. *Final and Binding Results:* If the parties reach a mutual agreement regarding a Claim, whether through approval of the Claim, direct negotiations, mediation, or otherwise; or if a Claim is approved in part and denied in part, or denied in full, and such actions become final and binding; then the results of the agreement or action on the Claim shall be incorporated in a Change Order to the extent they affect the Contract, including the Work, the Contract Times, or the Contract Price.

ARTICLE 13 – COST OF THE WORK; ALLOWANCES; UNIT PRICE WORK13.01 *Cost of the Work*

- A. *Purposes for Determination of Cost of the Work:* The term Cost of the Work means the sum of all costs necessary for the proper performance of the Work at issue, as further defined below. The provisions of this Paragraph 13.01 are used for two distinct purposes:
1. To determine Cost of the Work when Cost of the Work is a component of the Contract Price, under cost-plus-fee, time-and-materials, or other cost-based terms; or
 2. To determine the value of a Change Order, Change Proposal, Claim, set-off, or other adjustment in Contract Price. When the value of any such adjustment is determined on the basis of Cost of the Work, Contractor is entitled only to those additional or incremental costs required because of the change in the Work or because of the event giving rise to the adjustment.
- B. *Costs Included:* Except as otherwise may be agreed to in writing by Owner, costs included in the Cost of the Work shall be in amounts no higher than those prevailing in the locality of the Project, shall not include any of the costs itemized in Paragraph 13.01.C, and shall include only the following items:
1. Payroll costs for employees in the direct employ of Contractor in the performance of the Work under schedules of job classifications agreed upon by Owner and Contractor. Such employees shall include, without limitation, superintendents, foremen, and other personnel employed full time on the Work. Payroll costs for employees not employed full time on the Work shall be apportioned on the basis of their time spent on the Work. Payroll costs shall include, but not be limited to, salaries and wages plus the cost of fringe benefits, which shall include social security contributions, unemployment, excise, and payroll taxes, workers' compensation, health and retirement benefits, bonuses, sick leave, and vacation and holiday pay applicable thereto. The expenses of performing Work outside of regular working hours, on Saturday, Sunday, or legal holidays, shall be included in the above to the extent authorized by Owner.
 2. Cost of all materials and equipment furnished and incorporated in the Work, including costs of transportation and storage thereof, and Suppliers' field services required in connection therewith. All cash discounts shall accrue to Contractor unless Owner deposits funds with Contractor with which to make payments, in which case the cash discounts shall accrue to Owner. All trade discounts, rebates, and refunds and returns from sale of surplus materials and equipment shall accrue to Owner, and Contractor shall make provisions so that they may be obtained.
 3. Payments made by Contractor to Subcontractors for Work performed by Subcontractors. If required by Owner, Contractor shall obtain competitive bids from subcontractors acceptable to Owner and Contractor and shall deliver such bids to Owner, who will then determine, with the advice of Engineer, which bids, if any, will be acceptable. If any subcontract provides that the Subcontractor is to be paid on the basis of Cost of the Work plus a fee, the Subcontractor's Cost of the Work and fee shall be determined in the same manner as Contractor's Cost of the Work and fee as provided in this Paragraph 13.01.

4. Costs of special consultants (including but not limited to engineers, architects, testing laboratories, surveyors, attorneys, and accountants) employed for services specifically related to the Work.
5. Supplemental costs including the following:
 - a. The proportion of necessary transportation, travel, and subsistence expenses of Contractor's employees incurred in discharge of duties connected with the Work.
 - b. Cost, including transportation and maintenance, of all materials, supplies, equipment, machinery, appliances, office, and temporary facilities at the Site, and hand tools not owned by the workers, which are consumed in the performance of the Work, and cost, less market value, of such items used but not consumed which remain the property of Contractor.
 - c. Rentals of all construction equipment and machinery, and the parts thereof, whether rented from Contractor or others in accordance with rental agreements approved by Owner with the advice of Engineer, and the costs of transportation, loading, unloading, assembly, dismantling, and removal thereof. All such costs shall be in accordance with the terms of said rental agreements. The rental of any such equipment, machinery, or parts shall cease when the use thereof is no longer necessary for the Work.
 - d. Sales, consumer, use, and other similar taxes related to the Work, and for which Contractor is liable, as imposed by Laws and Regulations.
 - e. Deposits lost for causes other than negligence of Contractor, any Subcontractor, or anyone directly or indirectly employed by any of them or for whose acts any of them may be liable, and royalty payments and fees for permits and licenses.
 - f. Losses and damages (and related expenses) caused by damage to the Work, not compensated by insurance or otherwise, sustained by Contractor in connection with the performance of the Work (except losses and damages within the deductible amounts of property insurance established in accordance with Paragraph 6.05), provided such losses and damages have resulted from causes other than the negligence of Contractor, any Subcontractor, or anyone directly or indirectly employed by any of them or for whose acts any of them may be liable. Such losses shall include settlements made with the written consent and approval of Owner. No such losses, damages, and expenses shall be included in the Cost of the Work for the purpose of determining Contractor's fee.
 - g. The cost of utilities, fuel, and sanitary facilities at the Site.
 - h. Minor expenses such as communication service at the Site, express and courier services, and similar petty cash items in connection with the Work.
 - i. The costs of premiums for all bonds and insurance that Contractor is required by the Contract Documents to purchase and maintain.

- C. *Costs Excluded:* The term Cost of the Work shall not include any of the following items:
1. Payroll costs and other compensation of Contractor's officers, executives, principals (of partnerships and sole proprietorships), general managers, safety managers, engineers, architects, estimators, attorneys, auditors, accountants, purchasing and contracting agents, expeditors, timekeepers, clerks, and other personnel employed by Contractor, whether at the Site or in Contractor's principal or branch office for general administration of the Work and not specifically included in the agreed upon schedule of job classifications referred to in Paragraph 13.01.B.1 or specifically covered by Paragraph 13.01.B.4. The payroll costs and other compensation excluded here are to be considered administrative costs covered by the Contractor's fee.
 2. Expenses of Contractor's principal and branch offices other than Contractor's office at the Site.
 3. Any part of Contractor's capital expenses, including interest on Contractor's capital employed for the Work and charges against Contractor for delinquent payments.
 4. Costs due to the negligence of Contractor, any Subcontractor, or anyone directly or indirectly employed by any of them or for whose acts any of them may be liable, including but not limited to, the correction of defective Work, disposal of materials or equipment wrongly supplied, and making good any damage to property.
 5. Other overhead or general expense costs of any kind and the costs of any item not specifically and expressly included in Paragraph 13.01.B.
- D. *Contractor's Fee:* When the Work as a whole is performed on the basis of cost-plus, Contractor's fee shall be determined as set forth in the Agreement. When the value of any Work covered by a Change Order, Change Proposal, Claim, set-off, or other adjustment in Contract Price is determined on the basis of Cost of the Work, Contractor's fee shall be determined as set forth in Paragraph 11.04.C.
- E. *Documentation:* Whenever the Cost of the Work for any purpose is to be determined pursuant to this Article 13, Contractor shall establish and maintain records thereof in accordance with generally accepted accounting practices and submit in a form acceptable to Engineer an itemized cost breakdown together with supporting data.

13.02 Allowances

- A. It is understood that Contractor has included in the Contract Price all allowances so named in the Contract Documents and shall cause the Work so covered to be performed for such sums and by such persons or entities as may be acceptable to Owner and Engineer.
- B. *Cash Allowances:* Contractor agrees that:
1. the cash allowances include the cost to Contractor (less any applicable trade discounts) of materials and equipment required by the allowances to be delivered at the Site, and all applicable taxes; and

2. Contractor's costs for unloading and handling on the Site, labor, installation, overhead, profit, and other expenses contemplated for the cash allowances have been included in the Contract Price and not in the allowances, and no demand for additional payment on account of any of the foregoing will be valid.
- C. *Contingency Allowance*: Contractor agrees that a contingency allowance, if any, is for the sole use of Owner to cover unanticipated costs.
- D. Prior to final payment, an appropriate Change Order will be issued as recommended by Engineer to reflect actual amounts due Contractor on account of Work covered by allowances, and the Contract Price shall be correspondingly adjusted.

13.03 *Unit Price Work*

- A. Where the Contract Documents provide that all or part of the Work is to be Unit Price Work, initially the Contract Price will be deemed to include for all Unit Price Work an amount equal to the sum of the unit price for each separately identified item of Unit Price Work times the estimated quantity of each item as indicated in the Agreement.
- B. The estimated quantities of items of Unit Price Work are not guaranteed and are solely for the purpose of comparison of Bids and determining an initial Contract Price. Payments to Contractor for Unit Price Work will be based on actual quantities.
- C. Each unit price will be deemed to include an amount considered by Contractor to be adequate to cover Contractor's overhead and profit for each separately identified item.
- D. Engineer will determine the actual quantities and classifications of Unit Price Work performed by Contractor. Engineer will review with Contractor the Engineer's preliminary determinations on such matters before rendering a written decision thereon (by recommendation of an Application for Payment or otherwise). Engineer's written decision thereon will be final and binding (except as modified by Engineer to reflect changed factual conditions or more accurate data) upon Owner and Contractor, subject to the provisions of the following paragraph.
- E. Within 30 days of Engineer's written decision under the preceding paragraph, Contractor may submit a Change Proposal, or Owner may file a Claim, seeking an adjustment in the Contract Price if:
 1. the quantity of any item of Unit Price Work performed by Contractor differs materially and significantly from the estimated quantity of such item indicated in the Agreement;
 2. there is no corresponding adjustment with respect to any other item of Work; and
 3. Contractor believes that it is entitled to an increase in Contract Price as a result of having incurred additional expense or Owner believes that Owner is entitled to a decrease in Contract Price, and the parties are unable to agree as to the amount of any such increase or decrease.

ARTICLE 14 – TESTS AND INSPECTIONS; CORRECTION, REMOVAL OR ACCEPTANCE OF DEFECTIVE WORK

14.01 *Access to Work*

- A. Owner, Engineer, their consultants and other representatives and personnel of Owner, independent testing laboratories, and authorities having jurisdiction will have access

to the Site and the Work at reasonable times for their observation, inspection, and testing. Contractor shall provide them proper and safe conditions for such access and advise them of Contractor's safety procedures and programs so that they may comply therewith as applicable.

14.02 *Tests, Inspections, and Approvals*

- A. Contractor shall give Engineer timely notice of readiness of the Work (or specific parts thereof) for all required inspections and tests, and shall cooperate with inspection and testing personnel to facilitate required inspections and tests.
- B. **This item intentionally deleted from these General Conditions. Section 2 – Testing and Control of Materials in the Specifications covers this subject.**
- C. If Laws or Regulations of any public body having jurisdiction require any Work (or part thereof) specifically to be inspected, tested, or approved by an employee or other representative of such public body, Contractor shall assume full responsibility for arranging and obtaining such inspections, tests, or approvals, pay all costs in connection therewith, and furnish Engineer the required certificates of inspection or approval.
- D. Contractor shall be responsible for arranging, obtaining, and paying for all inspections and tests required:
 - 1. by the Contract Documents, unless the Contract Documents expressly allocate responsibility for a specific inspection or test to Owner;
 - 2. to attain Owner's and Engineer's acceptance of materials or equipment to be incorporated in the Work;
 - 3. by manufacturers of equipment furnished under the Contract Documents;
 - 4. for testing, adjusting, and balancing of mechanical, electrical, and other equipment to be incorporated into the Work; and
 - 5. for acceptance of materials, mix designs, or equipment submitted for approval prior to Contractor's purchase thereof for incorporation in the Work.

Such inspections and tests shall be performed by independent inspectors, testing laboratories, or other qualified individuals or entities acceptable to Owner and Engineer.

- E. If the Contract Documents require the Work (or part thereof) to be approved by Owner, Engineer, or another designated individual or entity, then Contractor shall assume full responsibility for arranging and obtaining such approvals.
- F. If any Work (or the work of others) that is to be inspected, tested, or approved is covered by Contractor without written concurrence of Engineer, Contractor shall, if requested by Engineer, uncover such Work for observation. Such uncovering shall be at Contractor's expense unless Contractor had given Engineer timely notice of Contractor's intention to cover the same and Engineer had not acted with reasonable promptness in response to such notice.

14.03 *Defective Work*

- A. *Contractor's Obligation:* It is Contractor's obligation to assure that the Work is not defective.

- B. *Engineer's Authority*: Engineer has the authority to determine whether Work is defective, and to reject defective Work.
- C. *Notice of Defects*: Prompt notice of all defective Work of which Owner or Engineer has actual knowledge will be given to Contractor.
- D. *Correction, or Removal and Replacement*: Promptly after receipt of written notice of defective Work, Contractor shall correct all such defective Work, whether or not fabricated, installed, or completed, or, if Engineer has rejected the defective Work, remove it from the Project and replace it with Work that is not defective.
- E. *Preservation of Warranties*: When correcting defective Work, Contractor shall take no action that would void or otherwise impair Owner's special warranty and guarantee, if any, on said Work.
- F. *Costs and Damages*: In addition to its correction, removal, and replacement obligations with respect to defective Work, Contractor shall pay all claims, costs, losses, and damages arising out of or relating to defective Work, including but not limited to the cost of the inspection, testing, correction, removal, replacement, or reconstruction of such defective Work, fines levied against Owner by governmental authorities because the Work is defective, and the costs of repair or replacement of work of others resulting from defective Work. Prior to final payment, if Owner and Contractor are unable to agree as to the measure of such claims, costs, losses, and damages resulting from defective Work, then Owner may impose a reasonable set-off against payments due under Article 15.

14.04 *Acceptance of Defective Work*

- A. If, instead of requiring correction or removal and replacement of defective Work, Owner prefers to accept it, Owner may do so (subject, if such acceptance occurs prior to final payment, to Engineer's confirmation that such acceptance is in general accord with the design intent and applicable engineering principles, and will not endanger public safety). Contractor shall pay all claims, costs, losses, and damages attributable to Owner's evaluation of and determination to accept such defective Work (such costs to be approved by Engineer as to reasonableness), and for the diminished value of the Work to the extent not otherwise paid by Contractor. If any such acceptance occurs prior to final payment, the necessary revisions in the Contract Documents with respect to the Work shall be incorporated in a Change Order. If the parties are unable to agree as to the decrease in the Contract Price, reflecting the diminished value of Work so accepted, then Owner may impose a reasonable set-off against payments due under Article 15. If the acceptance of defective Work occurs after final payment, Contractor shall pay an appropriate amount to Owner.

14.05 *Uncovering Work*

- A. Engineer has the authority to require special inspection or testing of the Work, whether or not the Work is fabricated, installed, or completed.
- B. If any Work is covered contrary to the written request of Engineer, then Contractor shall, if requested by Engineer, uncover such Work for Engineer's observation, and then replace the covering, all at Contractor's expense.
- C. If Engineer considers it necessary or advisable that covered Work be observed by Engineer or inspected or tested by others, then Contractor, at Engineer's request, shall

uncover, expose, or otherwise make available for observation, inspection, or testing as Engineer may require, that portion of the Work in question, and provide all necessary labor, material, and equipment.

1. If it is found that the uncovered Work is defective, Contractor shall be responsible for all claims, costs, losses, and damages arising out of or relating to such uncovering, exposure, observation, inspection, and testing, and of satisfactory replacement or reconstruction (including but not limited to all costs of repair or replacement of work of others); and pending Contractor's full discharge of this responsibility the Owner shall be entitled to impose a reasonable set-off against payments due under Article 15.
2. If the uncovered Work is not found to be defective, Contractor shall be allowed an increase in the Contract Price or an extension of the Contract Times, or both, directly attributable to such uncovering, exposure, observation, inspection, testing, replacement, and reconstruction. If the parties are unable to agree as to the amount or extent thereof, then Contractor may submit a Change Proposal within 30 days of the determination that the Work is not defective.

14.06 *Owner May Stop the Work*

- A. If the Work is defective, or Contractor fails to supply sufficient skilled workers or suitable materials or equipment, or fails to perform the Work in such a way that the completed Work will conform to the Contract Documents, then Owner may order Contractor to stop the Work, or any portion thereof, until the cause for such order has been eliminated; however, this right of Owner to stop the Work shall not give rise to any duty on the part of Owner to exercise this right for the benefit of Contractor, any Subcontractor, any Supplier, any other individual or entity, or any surety for, or employee or agent of any of them.

14.07 *Owner May Correct Defective Work*

- A. If Contractor fails within a reasonable time after written notice from Engineer to correct defective Work, or to remove and replace rejected Work as required by Engineer, or if Contractor fails to perform the Work in accordance with the Contract Documents, or if Contractor fails to comply with any other provision of the Contract Documents, then Owner may, after seven days written notice to Contractor, correct or remedy any such deficiency.
- B. In exercising the rights and remedies under this Paragraph 14.07, Owner shall proceed expeditiously. In connection with such corrective or remedial action, Owner may exclude Contractor from all or part of the Site, take possession of all or part of the Work and suspend Contractor's services related thereto, and incorporate in the Work all materials and equipment stored at the Site or for which Owner has paid Contractor but which are stored elsewhere. Contractor shall allow Owner, Owner's representatives, agents and employees, Owner's other contractors, and Engineer and Engineer's consultants access to the Site to enable Owner to exercise the rights and remedies under this paragraph.
- C. All claims, costs, losses, and damages incurred or sustained by Owner in exercising the rights and remedies under this Paragraph 14.07 will be charged against Contractor as set-offs against payments due under Article 15. Such claims, costs, losses and damages will include but not be limited to all costs of repair, or replacement of work

of others destroyed or damaged by correction, removal, or replacement of Contractor's defective Work.

- D. Contractor shall not be allowed an extension of the Contract Times because of any delay in the performance of the Work attributable to the exercise by Owner of Owner's rights and remedies under this Paragraph 14.07.

ARTICLE 15 – PAYMENTS TO CONTRACTOR; SET-OFFS; COMPLETION; CORRECTION PERIOD

15.01 *Progress Payments*

- A. *Basis for Progress Payments:* The Schedule of Values established as provided in Article 2 will serve as the basis for progress payments and will be incorporated into a form of Application for Payment acceptable to Engineer. Progress payments on account of Unit Price Work will be based on the number of units completed during the pay period, as determined under the provisions of Paragraph 13.03. Progress payments for cost-based Work will be based on Cost of the Work completed by Contractor during the pay period.
- B. *Applications for Payments:*
1. At least 20 days before the date established in the Agreement for each progress payment (but not more often than once a month), Contractor shall submit to Engineer for review an Application for Payment filled out and signed by Contractor covering the Work completed as of the date of the Application and accompanied by such supporting documentation as is required by the Contract Documents. If payment is requested on the basis of materials and equipment not incorporated in the Work but delivered and suitably stored at the Site or at another location agreed to in writing, the Application for Payment shall also be accompanied by a bill of sale, invoice, or other documentation warranting that Owner has received the materials and equipment free and clear of all Liens, and evidence that the materials and equipment are covered by appropriate property insurance, a warehouse bond, or other arrangements to protect Owner's interest therein, all of which must be satisfactory to Owner.
 2. **This item intentionally deleted.**
 3. The amount of retainage with respect to progress payments will be as stipulated in the Agreement.
- C. *Review of Applications:*
1. Engineer will, within 10 days after receipt of each Application for Payment, including each resubmittal, either indicate in writing a recommendation of payment and present the Application to Owner, or return the Application to Contractor indicating in writing Engineer's reasons for refusing to recommend payment. In the latter case, Contractor may make the necessary corrections and resubmit the Application.
 2. Engineer's recommendation of any payment requested in an Application for Payment will constitute a representation by Engineer to Owner, based on Engineer's observations of the executed Work as an experienced and qualified design professional, and on Engineer's review of the Application for Payment and

- the accompanying data and schedules, that to the best of Engineer's knowledge, information and belief:
- a. the Work has progressed to the point indicated;
 - b. the quality of the Work is generally in accordance with the Contract Documents (subject to an evaluation of the Work as a functioning whole prior to or upon Substantial Completion, the results of any subsequent tests called for in the Contract Documents, a final determination of quantities and classifications for Unit Price Work under Paragraph 13.03, and any other qualifications stated in the recommendation); and
 - c. the conditions precedent to Contractor's being entitled to such payment appear to have been fulfilled in so far as it is Engineer's responsibility to observe the Work.
3. By recommending any such payment Engineer will not thereby be deemed to have represented that:
- a. inspections made to check the quality or the quantity of the Work as it has been performed have been exhaustive, extended to every aspect of the Work in progress, or involved detailed inspections of the Work beyond the responsibilities specifically assigned to Engineer in the Contract; or
 - b. there may not be other matters or issues between the parties that might entitle Contractor to be paid additionally by Owner or entitle Owner to withhold payment to Contractor.
4. Neither Engineer's review of Contractor's Work for the purposes of recommending payments nor Engineer's recommendation of any payment, including final payment, will impose responsibility on Engineer:
- a. to supervise, direct, or control the Work, or
 - b. for the means, methods, techniques, sequences, or procedures of construction, or the safety precautions and programs incident thereto, or
 - c. for Contractor's failure to comply with Laws and Regulations applicable to Contractor's performance of the Work, or
 - d. to make any examination to ascertain how or for what purposes Contractor has used the money paid on account of the Contract Price, or
 - e. to determine that title to any of the Work, materials, or equipment has passed to Owner free and clear of any Liens.
5. Engineer may refuse to recommend the whole or any part of any payment if, in Engineer's opinion, it would be incorrect to make the representations to Owner stated in Paragraph 15.01.C.2.
6. Engineer will recommend reductions in payment (set-offs) necessary in Engineer's opinion to protect Owner from loss because:
- a. the Work is defective, requiring correction or replacement;
 - b. the Contract Price has been reduced by Change Orders;

- c. Owner has been required to correct defective Work in accordance with Paragraph 14.07, or has accepted defective Work pursuant to Paragraph 14.04;
- d. Owner has been required to remove or remediate a Hazardous Environmental Condition for which Contractor is responsible; or
- e. Engineer has actual knowledge of the occurrence of any of the events that would constitute a default by Contractor and therefore justify termination for cause under the Contract Documents.

D. *Payment Becomes Due:*

1. **The Owner will make payments promptly as funds for such payments become available from funding agencies or as otherwise agreed.**

E. *Reductions in Payment by Owner:*

1. In addition to any reductions in payment (set-offs) recommended by Engineer, Owner is entitled to impose a set-off against payment based on any of the following:
 - a. claims have been made against Owner on account of Contractor's conduct in the performance or furnishing of the Work, or Owner has incurred costs, losses, or damages on account of Contractor's conduct in the performance or furnishing of the Work, including but not limited to claims, costs, losses, or damages from workplace injuries, adjacent property damage, non-compliance with Laws and Regulations, and patent infringement;
 - b. Contractor has failed to take reasonable and customary measures to avoid damage, delay, disruption, and interference with other work at or adjacent to the Site;
 - c. Contractor has failed to provide and maintain required bonds or insurance;
 - d. Owner has been required to remove or remediate a Hazardous Environmental Condition for which Contractor is responsible;
 - e. Owner has incurred extra charges or engineering costs related to submittal reviews, evaluations of proposed substitutes, tests and inspections, or return visits to manufacturing or assembly facilities;
 - f. the Work is defective, requiring correction or replacement;
 - g. Owner has been required to correct defective Work in accordance with Paragraph 14.07, or has accepted defective Work pursuant to Paragraph 14.04;
 - h. the Contract Price has been reduced by Change Orders;
 - i. an event that would constitute a default by Contractor and therefore justify a termination for cause has occurred;
 - j. liquidated damages have accrued as a result of Contractor's failure to achieve Milestones, Substantial Completion, or final completion of the Work;

- k. Liens have been filed in connection with the Work, except where Contractor has delivered a specific bond satisfactory to Owner to secure the satisfaction and discharge of such Liens;
 - l. there are other items entitling Owner to a set off against the amount recommended.
2. If Owner imposes any set-off against payment, whether based on its own knowledge or on the written recommendations of Engineer, Owner will give Contractor immediate written notice (with a copy to Engineer) stating the reasons for such action and the specific amount of the reduction, and promptly pay Contractor any amount remaining after deduction of the amount so withheld. Owner shall promptly pay Contractor the amount so withheld, or any adjustment thereto agreed to by Owner and Contractor, if Contractor remedies the reasons for such action. The reduction imposed shall be binding on Contractor unless it duly submits a Change Proposal contesting the reduction.
 3. Upon a subsequent determination that Owner's refusal of payment was not justified, the amount wrongfully withheld shall be treated as an amount due as determined by Paragraph 15.01.C.1 and subject to interest as provided in the Agreement.

15.02 *Contractor's Warranty of Title*

- A. Contractor warrants and guarantees that title to all Work, materials, and equipment furnished under the Contract will pass to Owner free and clear of (1) all Liens and other title defects, and (2) all patent, licensing, copyright, or royalty obligations, no later than seven days after the time of payment by Owner.

15.03 *Substantial Completion*

- A. When Contractor considers the entire Work ready for its intended use Contractor shall notify Owner and Engineer in writing that the entire Work is substantially complete and request that Engineer issue a **notice** of Substantial Completion.
- B. Promptly after Contractor's notification, Owner, Contractor, and Engineer shall make an inspection of the Work to determine the status of completion. If Engineer does not consider the Work substantially complete, Engineer will notify Contractor in writing giving the reasons therefor.
- C. If Engineer considers the Work substantially complete, Engineer will deliver to Owner **and Contractor** a preliminary **notice** of Substantial Completion which shall fix the date of Substantial Completion. Engineer shall attach to the **notice** a punch list of items to be completed or corrected before final payment. Owner shall have seven days after receipt of the preliminary **notice** during which to make written objection to Engineer as to any provisions of the **notice** or attached punch list. If, after considering the objections to the provisions of the preliminary **notice**, Engineer concludes that the Work is not substantially complete, Engineer will, within 14 days after submission of the preliminary **notice** to Owner, notify Contractor in writing that the Work is not substantially complete, stating the reasons therefor. If Owner does not object to the provisions of the **notice**, or if despite consideration of Owner's objections Engineer concludes that the Work is substantially complete, then Engineer will, within said 14 days, execute and deliver to Owner and Contractor a final **notice** of Substantial Completion (with a revised punch list of items to be completed or corrected) reflecting

such changes from the preliminary **notice** as Engineer believes justified after consideration of any objections from Owner.

- D. At the time of receipt of the preliminary **notice** of Substantial Completion, Owner and Contractor will confer regarding Owner's use or occupancy of the Work following Substantial Completion, review the builder's risk insurance policy with respect to the end of the builder's risk coverage, and confirm the transition to coverage of the Work under a permanent property insurance policy held by Owner. Unless Owner and Contractor agree otherwise in writing, Owner shall bear responsibility for security, operation, protection of the Work, property insurance, maintenance, heat, and utilities upon Owner's use or occupancy of the Work.
- E. After Substantial Completion the Contractor shall promptly begin work on the punch list of items to be completed or corrected prior to final payment. In appropriate cases Contractor may submit monthly Applications for Payment for completed punch list items, following the progress payment procedures set forth above.
- F. Owner shall have the right to exclude Contractor from the Site after the date of Substantial Completion subject to allowing Contractor reasonable access to remove its property and complete or correct items on the punch list.

15.04 *Partial Use or Occupancy*

- A. Prior to Substantial Completion of all the Work, Owner may use or occupy any substantially completed part of the Work which has specifically been identified in the Contract Documents, or which Owner, Engineer, and Contractor agree constitutes a separately functioning and usable part of the Work that can be used by Owner for its intended purpose without significant interference with Contractor's performance of the remainder of the Work, subject to the following conditions:
 - 1. At any time Owner may request in writing that Contractor permit Owner to use or occupy any such part of the Work that Owner believes to be substantially complete. If and when Contractor agrees that such part of the Work is substantially complete, Contractor, Owner, and Engineer will follow the procedures of Paragraph 15.03.A through E for that part of the Work.
 - 2. At any time Contractor may notify Owner and Engineer in writing that Contractor considers any such part of the Work substantially complete and request Engineer to issue a **notice** of Substantial Completion for that part of the Work.
 - 3. Within a reasonable time after either such request, Owner, Contractor, and Engineer shall make an inspection of that part of the Work to determine its status of completion. If Engineer does not consider that part of the Work to be substantially complete, Engineer will notify Owner and Contractor in writing giving the reasons therefor. If Engineer considers that part of the Work to be substantially complete, the provisions of Paragraph 15.03 will apply with respect to certification of Substantial Completion of that part of the Work and the division of responsibility in respect thereof and access thereto.
 - 4. No use or occupancy or separate operation of part of the Work may occur prior to compliance with the requirements of Paragraph 6.05 regarding builder's risk or other property insurance.

15.05 *Final Inspection*

- A. Upon written notice from Contractor that the entire Work or an agreed portion thereof is complete, Engineer will promptly make a final inspection with Owner and Contractor and will notify Contractor in writing of all particulars in which this inspection reveals that the Work, or agreed portion thereof, is incomplete or defective. Contractor shall immediately take such measures as are necessary to complete such Work or remedy such deficiencies.

15.06 *Final Payment*

A. *Application for Payment:*

1. After Contractor has, in the opinion of Engineer, satisfactorily completed all corrections identified during the final inspection and has delivered, in accordance with the Contract Documents, all maintenance and operating instructions, schedules, guarantees, bonds, certificates or other evidence of insurance, certificates of inspection, annotated record documents (as provided in Paragraph 7.11), and other documents, Contractor may make application for final payment.
2. The final Application for Payment shall be accompanied (except as previously delivered) by:
 - a. all documentation called for in the Contract Documents;
 - b. consent of the surety, if any, to final payment;
 - c. satisfactory evidence that all title issues have been resolved such that title to all Work, materials, and equipment has passed to Owner free and clear of any Liens or other title defects, or will so pass upon final payment.
 - d. a list of all disputes that Contractor believes are unsettled; and
 - e. complete and legally effective releases or waivers (satisfactory to Owner) of all Lien rights arising out of the Work, and of Liens filed in connection with the Work.
3. In lieu of the releases or waivers of Liens specified in Paragraph 15.06.A.2 and as approved by Owner, Contractor may furnish receipts or releases in full and an affidavit of Contractor that: (a) the releases and receipts include all labor, services, material, and equipment for which a Lien could be filed; and (b) all payrolls, material and equipment bills, and other indebtedness connected with the Work for which Owner might in any way be responsible, or which might in any way result in liens or other burdens on Owner's property, have been paid or otherwise satisfied. If any Subcontractor or Supplier fails to furnish such a release or receipt in full, Contractor may furnish a bond or other collateral satisfactory to Owner to indemnify Owner against any Lien, or Owner at its option may issue joint checks payable to Contractor and specified Subcontractors and Suppliers.

B. *Engineer's Review of Application and Acceptance:*

1. If, on the basis of Engineer's observation of the Work during construction and final inspection, and Engineer's review of the final Application for Payment and accompanying documentation as required by the Contract Documents, Engineer is satisfied that the Work has been completed and Contractor's other obligations under the Contract have been fulfilled, Engineer will, within ten days after receipt

of the final Application for Payment, indicate in writing Engineer's recommendation of final payment and present the Application for Payment to Owner for payment. Such recommendation shall account for any set-offs against payment that are necessary in Engineer's opinion to protect Owner from loss for the reasons stated above with respect to progress payments. At the same time Engineer will also give written notice to Owner and Contractor that the Work is acceptable, subject to the provisions of Paragraph 15.07. Otherwise, Engineer will return the Application for Payment to Contractor, indicating in writing the reasons for refusing to recommend final payment, in which case Contractor shall make the necessary corrections and resubmit the Application for Payment.

- C. *Completion of Work*: The Work is complete (subject to surviving obligations) when it is ready for final payment as established by the Engineer's written recommendation of final payment.
- D. *Payment Becomes Due*: Thirty days after the presentation to Owner of the final Application for Payment and accompanying documentation, the amount recommended by Engineer (less any further sum Owner is entitled to set off against Engineer's recommendation, including but not limited to set-offs for liquidated damages and set-offs allowed under the provisions above with respect to progress payments) will become due and shall be paid by Owner to Contractor.

15.07 *Waiver of Claims*

- A. The making of final payment will not constitute a waiver by Owner of claims or rights against Contractor. Owner expressly reserves claims and rights arising from unsettled Liens, from defective Work appearing after final inspection pursuant to Paragraph 15.05, from Contractor's failure to comply with the Contract Documents or the terms of any special guarantees specified therein, from outstanding Claims by Owner, or from Contractor's continuing obligations under the Contract Documents.
- B. The acceptance of final payment by Contractor will constitute a waiver by Contractor of all claims and rights against Owner other than those pending matters that have been duly submitted or appealed under the provisions of Article 17.

15.08 *Correction Period*

- A. If within one year after the date of Substantial Completion (or such longer period of time as may be prescribed by the terms of any applicable special guarantee required by the Contract Documents, or by any specific provision of the Contract Documents), any Work is found to be defective, or if the repair of any damages to the Site, adjacent areas that Contractor has arranged to use through construction easements or otherwise, and other adjacent areas used by Contractor as permitted by Laws and Regulations, is found to be defective, then Contractor shall promptly, without cost to Owner and in accordance with Owner's written instructions:
 - 1. correct the defective repairs to the Site or such other adjacent areas;
 - 2. correct such defective Work;
 - 3. if the defective Work has been rejected by Owner, remove it from the Project and replace it with Work that is not defective, and
 - 4. satisfactorily correct or repair or remove and replace any damage to other Work, to the work of others, or to other land or areas resulting therefrom.

- B. If Contractor does not promptly comply with the terms of Owner's written instructions, or in an emergency where delay would cause serious risk of loss or damage, Owner may have the defective Work corrected or repaired or may have the rejected Work removed and replaced. Contractor shall pay all claims, costs, losses, and damages (including but not limited to all fees and charges of engineers, architects, attorneys, and other professionals and all court or arbitration or other dispute resolution costs) arising out of or relating to such correction or repair or such removal and replacement (including but not limited to all costs of repair or replacement of work of others).
- C. In special circumstances where a particular item of equipment is placed in continuous service before Substantial Completion of all the Work, the correction period for that item may start to run from an earlier date if so provided in the Specifications.
- D. Where defective Work (and damage to other Work resulting therefrom) has been corrected or removed and replaced under this paragraph, the correction period hereunder with respect to such Work will be extended for an additional period of one year after such correction or removal and replacement has been satisfactorily completed.
- E. Contractor's obligations under this paragraph are in addition to all other obligations and warranties. The provisions of this paragraph shall not be construed as a substitute for, or a waiver of, the provisions of any applicable statute of limitation or repose.

ARTICLE 16 – SUSPENSION OF WORK AND TERMINATION

16.01 *Owner May Suspend Work*

- A. At any time and without cause, Owner may suspend the Work or any portion thereof for a period of not more than 90 consecutive days by written notice to Contractor and Engineer. Such notice will fix the date on which Work will be resumed. Contractor shall resume the Work on the date so fixed. Contractor shall be entitled to an adjustment in the Contract Price or an extension of the Contract Times, or both, directly attributable to any such suspension. Any Change Proposal seeking such adjustments shall be submitted no later than 30 days after the date fixed for resumption of Work.

16.02 *Owner May Terminate for Cause*

- A. The occurrence of any one or more of the following events will constitute a default by Contractor and justify termination for cause:
 - 1. Contractor's persistent failure to perform the Work in accordance with the Contract Documents (including, but not limited to, failure to supply sufficient skilled workers or suitable materials or equipment or failure to adhere to the Progress Schedule);
 - 2. Failure of Contractor to perform or otherwise to comply with a material term of the Contract Documents;
 - 3. Contractor's disregard of Laws or Regulations of any public body having jurisdiction; or
 - 4. Contractor's repeated disregard of the authority of Owner or Engineer.

- B. If one or more of the events identified in Paragraph 16.02.A occurs, then after giving Contractor (and any surety) ten days written notice that Owner is considering a declaration that Contractor is in default and termination of the contract, Owner may proceed to:
 - 1. declare Contractor to be in default, and give Contractor (and any surety) notice that the Contract is terminated; and
 - 2. enforce the rights available to Owner under any applicable performance bond.
- C. Subject to the terms and operation of any applicable performance bond, if Owner has terminated the Contract for cause, Owner may exclude Contractor from the Site, take possession of the Work, incorporate in the Work all materials and equipment stored at the Site or for which Owner has paid Contractor but which are stored elsewhere, and complete the Work as Owner may deem expedient.
- D. Owner may not proceed with termination of the Contract under Paragraph 16.02.B if Contractor within seven days of receipt of notice of intent to terminate begins to correct its failure to perform and proceeds diligently to cure such failure.
- E. If Owner proceeds as provided in Paragraph 16.02.B, Contractor shall not be entitled to receive any further payment until the Work is completed. If the unpaid balance of the Contract Price exceeds the cost to complete the Work, including all related claims, costs, losses, and damages (including but not limited to all fees and charges of engineers, architects, attorneys, and other professionals) sustained by Owner, such excess will be paid to Contractor. If the cost to complete the Work including such related claims, costs, losses, and damages exceeds such unpaid balance, Contractor shall pay the difference to Owner. Such claims, costs, losses, and damages incurred by Owner will be reviewed by Engineer as to their reasonableness and, when so approved by Engineer, incorporated in a Change Order. When exercising any rights or remedies under this paragraph, Owner shall not be required to obtain the lowest price for the Work performed.
- F. Where Contractor's services have been so terminated by Owner, the termination will not affect any rights or remedies of Owner against Contractor then existing or which may thereafter accrue, or any rights or remedies of Owner against Contractor or any surety under any payment bond or performance bond. Any retention or payment of money due Contractor by Owner will not release Contractor from liability.
- G. If and to the extent that Contractor has provided a performance bond under the provisions of Paragraph 6.01.A, the provisions of that bond shall govern over any inconsistent provisions of Paragraphs 16.02.B and 16.02.D.

16.03 *Owner May Terminate For Convenience*

- A. Upon seven days written notice to Contractor and Engineer, Owner may, without cause and without prejudice to any other right or remedy of Owner, terminate the Contract. In such case, Contractor shall be paid for (without duplication of any items):
 - 1. completed and acceptable Work executed in accordance with the Contract Documents prior to the effective date of termination, including fair and reasonable sums for overhead and profit on such Work;
 - 2. expenses sustained prior to the effective date of termination in performing services and furnishing labor, materials, or equipment as required by the Contract

Documents in connection with uncompleted Work, plus fair and reasonable sums for overhead and profit on such expenses; and

3. other reasonable expenses directly attributable to termination, including costs incurred to prepare a termination for convenience cost proposal.
- B. Contractor shall not be paid on account of loss of anticipated overhead, profits, or revenue, or other economic loss arising out of or resulting from such termination.

16.04 *Contractor May Stop Work or Terminate*

- A. If, through no act or fault of Contractor, (1) the Work is suspended for more than 90 consecutive days by Owner or under an order of court or other public authority, or (2) Engineer fails to act on any Application for Payment within 30 days after it is submitted, or (3) Owner fails to pay Contractor as provided by **15.01.D.** any sum finally determined to be due, then Contractor may, upon seven days written notice to Owner and Engineer, and provided Owner or Engineer do not remedy such suspension or failure within that time, terminate the contract and recover from Owner payment on the same terms as provided in Paragraph 16.03.
- B. In lieu of terminating the Contract and without prejudice to any other right or remedy, if Engineer has failed to act on an Application for Payment within 30 days after it is submitted, or Owner has failed to pay Contractor as provided by **15.01.D.** any sum finally determined to be due, Contractor may, seven days after written notice to Owner and Engineer, stop the Work until payment is made of all such amounts due Contractor, including interest thereon. The provisions of this paragraph are not intended to preclude Contractor from submitting a Change Proposal for an adjustment in Contract Price or Contract Times or otherwise for expenses or damage directly attributable to Contractor's stopping the Work as permitted by this paragraph.

ARTICLE 17 – FINAL RESOLUTION OF DISPUTES

17.01 *Methods and Procedures*

- A. *Disputes Subject to Final Resolution:* The following disputed matters are subject to final resolution under the provisions of this Article:
1. A timely appeal of an approval in part and denial in part of a Claim, or of a denial in full; and
 2. Disputes between Owner and Contractor concerning the Work or obligations under the Contract Documents, and arising after final payment has been made.
- B. *Final Resolution of Disputes:* For any dispute subject to resolution under this Article, Owner or Contractor may:
1. elect in writing to invoke the dispute resolution process provided for in the Supplementary Conditions; or
 2. agree with the other party to submit the dispute to another dispute resolution process; or
 3. if no dispute resolution process is provided for in the Supplementary Conditions or mutually agreed to, give written notice to the other party of the intent to submit the dispute to a court of competent jurisdiction.

ARTICLE 18 – MISCELLANEOUS

18.01 *Giving Notice*

- A. Whenever any provision of the Contract Documents requires the giving of written notice, it will be deemed to have been validly given if:
1. delivered in person, by a commercial courier service or otherwise, to the individual or to a member of the firm or to an officer of the corporation for which it is intended; or
 2. delivered at or sent by registered or certified mail, postage prepaid, to the last business address known to the sender of the notice.

18.02 *Computation of Times*

- A. When any period of time is referred to in the Contract by days, it will be computed to exclude the first and include the last day of such period. If the last day of any such period falls on a Saturday or Sunday or on a day made a legal holiday by the law of the applicable jurisdiction, such day will be omitted from the computation.

18.03 *Cumulative Remedies*

- A. The duties and obligations imposed by these General Conditions and the rights and remedies available hereunder to the parties hereto are in addition to, and are not to be construed in any way as a limitation of, any rights and remedies available to any or all of them which are otherwise imposed or available by Laws or Regulations, by special warranty or guarantee, or by other provisions of the Contract. The provisions of this paragraph will be as effective as if repeated specifically in the Contract Documents in connection with each particular duty, obligation, right, and remedy to which they apply.

18.04 *Limitation of Damages*

- A. With respect to any and all Change Proposals, Claims, disputes subject to final resolution, and other matters at issue, neither Owner nor Engineer, nor any of their officers, directors, members, partners, employees, agents, consultants, or subcontractors, shall be liable to Contractor for any claims, costs, losses, or damages sustained by Contractor on or in connection with any other project or anticipated project.

18.05 *No Waiver*

- A. A party's non-enforcement of any provision shall not constitute a waiver of that provision, nor shall it affect the enforceability of that provision or of the remainder of this Contract.

18.06 *Survival of Obligations*

- A. All representations, indemnifications, warranties, and guarantees made in, required by, or given in accordance with the Contract, as well as all continuing obligations indicated in the Contract, will survive final payment, completion, and acceptance of the Work or termination or completion of the Contract or termination of the services of Contractor.

18.07 *Controlling Law*

A. This Contract is to be governed by the law of the state in which the Project is located.

18.08 *Headings*

A. Article and paragraph headings are inserted for convenience only and do not constitute parts of these General Conditions.

Supplementary Conditions – SRF – Kentucky
August 2014

SUPPLEMENTARY CONDITIONS – SRF PROJECTS
COMMONWEALTH OF KENTUCKY

1. Subsurface and Physical Conditions (Article 5.03)

As provided by Article 5.03 (page 14) of the General Conditions, no subsurface conditions are known unless included at the end of Section 1 of the Detailed Specifications.

2. Hazardous Environmental Condition at Site (Article 5.06)

Neither the Owner nor the Engineer are aware of any hazardous environmental conditions on this project, however no specific examinations have been performed unless a report of such conditions is included in Section 1 of the Detailed Specifications.

3. Safety and Protection (Article 7.12)

Article 7.12 C refers to an Owner Safety Program, if any. If such program is known to exist to the Engineer, it will be identified in Section 1 of the Detailed Specifications.

4. Coordination (Article 8.02)

Section 1 of the Detailed Specifications and/or the Plans will show any other contracts or contractors which will interface with this work.

5. Progress Payments (Article 15.01)

Article 15.01 (page 58) is hereby amended to allow the Owner 30 days after receipt of the Engineer's approved Application for Payment (also known as Pay Request) in order to make payment to the Contractor.

Add the following as Article 15.01 A.2:

The Contractor affirms by the submission of the second Application for Payment (Pay Request) that the Contractor is discharging all financial obligations pertaining to this Contract in the customary business manner. Before final payment, as per Article 15.06, is made, the Contractor will be required to furnish an affidavit that all financial and other obligations related to this project have been satisfied listing any exceptions.

Supplementary Conditions – SRF – Kentucky
August 2014

6. Listing of the Duties, Responsibilities and Limitations of Authority of the Resident Project Representative

A copy of this document as it appears in the Owner-Engineer Agreement is attached to these Supplementary Conditions.

7. Contract Time and Liquidated Damages

The time of completion for this Contract is Two Hundred Seventy (270) calendar days. If the contractor fails to complete the work within the specified time, liquidated damages in the amount of One Thousand Dollars (\$1,000.00) per calendar day will apply.

8. Trees, Vegetation, and Soil Erosion

Reasonable care shall be taken to avoid damage to vegetation during construction. Ornamental shrubbery and tree branches shall be temporarily tied back, where appropriate, to minimize damage. Damaged trees shall be trimmed to improve appearance of tree. Damaged tree trunks shall be treated with dressing. The Contractor shall take reasonable care to prevent siltation and soil erosion during construction.

9. Work Hours and Safety

The Contractor shall comply with OSHA (P.L. 91-596) and the Contract Work Hours and Safety Standards Act (P.L. 91-54).

10. Change Orders

Change orders for the construction contract shall comply with KIA Procurement Guidance for Construction and Equipment Contracts. Change orders exceeding \$100,000 shall include cost, pricing, and certification as required by Procurement Guidance for Construction and Equipment Contracts.

11. Compliance with Title VI of the Civil Rights Act of 1964

Bidders must comply with Title VI of the Civil Rights Act of 1964, the Anti-Kickback Act, the Contract Work Hours Standard Act, and 40 CFR 31.36 L (3, 4 & 6).

12. Wastewater Bypassing

No wastewater bypassing shall occur during construction unless a schedule has been approved by the Commonwealth and/or EPA/NEPA permit if required.

Effective February 10, 2011

A LISTING OF THE DUTIES, RESPONSIBILITIES AND
LIMITATIONS OF AUTHORITY OF THE RESIDENT PROJECT REPRESENTATIVE

ENGINEER shall furnish a Resident Project Representative (RPR) to assist ENGINEER in observing performance of the Work of the Contractor.

Through more extensive on-site observations of the Work in progress and field checks of material and equipment by the RPR and assistants, ENGINEER shall endeavor to provide further protection for OWNER against defects and deficiencies in the Work but the furnishing of such services will not make ENGINEER responsible for or give ENGINEER control over construction means, methods, techniques, sequences or procedures, or for safety precautions or programs or responsibility for CONTRACTOR's failure to perform the Work in accordance with the Contract Documents.

The duties and responsibilities of the RPR are limited to those of ENGINEER in ENGINEER's agreement with the OWNER and in the construction Contract Documents, and are further limited and described as follows:

A. General

RPR is ENGINEER's agent at the site, will act as directed by and under the supervision of ENGINEER, and will confer with ENGINEER regarding RPR's actions. RPR's dealings in matters pertaining to the on-site work shall in general be with ENGINEER and CONTRACTOR keeping OWNER advised as necessary. RPR's dealings with subcontractors shall only be through or with the full knowledge and approval of CONTRACTOR. RPR shall generally communicate with OWNER with the knowledge of and under the direction of ENGINEER.

B. Duties and Responsibilities of RPR

1. Schedule: Review the progress schedule, schedule of Shop Drawings submittals and schedule of values prepared by CONTRACTOR and consult with ENGINEER concerning acceptability.
2. Conferences and Meetings: Attend meetings with CONTRACTOR, such as preconstruction conferences, progress meetings, job conferences and other project-related meetings.
3. Liaison:
 - a. Serve as ENGINEER's liaison with CONTRACTOR, working principally through CONTRACTOR's superintendent and assist in understanding the intent of the Contract Documents; and assist ENGINEER in serving as OWNER's liaison with CONTRACTOR

Effective February 10, 2011

- when CONTRACTOR's operations affect OWNER's on-site operations.
- b. Assist in obtaining from OWNER additional details or information, when required for proper execution of the Work.
4. Shop Drawings and Samples:
- a. Record date of receipt of Shop Drawings and samples.
 - b. Advise ENGINEER and CONTRACTOR of the commencement of any Work requiring a Shop Drawing or sample if the submittal has not been approved by ENGINEER.
5. Review of Work, Rejection of Defective Work, Visiting Inspectors and Tests:
- a. Conduct on-site observations of the Work in progress to assist ENGINEER in determining if the Work is in general proceeding in accordance with the Contract Documents.
 - b. Report to ENGINEER whenever RPR believes that any Work is unsatisfactory, faulty or defective or does not conform to the Contract documents, or has been damaged, or does not meet the requirements of any test or approval required to be made; and advise ENGINEER of Work that RPR believes should be corrected or rejected or should be uncovered for observation, or requires special testing or approval.
 - c. Verify that tests, equipment and system startups and operating and maintenance training are conducted in the presence of appropriate personnel, and that CONTRACTOR maintains adequate records thereof; and observe, record and report to ENGINEER appropriate details relative to the test procedures and startups.
 - d. Accompany visiting inspectors representing public or other agencies having jurisdiction over the Project, record the results of these inspections and report to ENGINEER.
6. Interpretation of Contract Documents: Report to ENGINEER when clarifications and interpretations of the Contract Documents are needed and transmit to CONTRACTOR clarifications and interpretations as issued by ENGINEER.
7. Modifications: Consider and evaluate CONTRACTOR's suggestions for modifications in Drawings or Specifications and report with RPR's

Effective February 10, 2011

recommendations to ENGINEER. Transmit to CONTRACTOR decisions as issued by ENGINEER.

8. Records:

- a. Maintain orderly files for correspondence, reports of job conferences, Shop Drawings and samples, reproductions of original Contract Documents including all Work Directive Changes, Addenda, Change Orders, Field Orders, additional Drawings issued subsequent to the execution of the Contract, ENGINEER's clarifications and interpretations of the Contract Documents, progress reports, and other Project related documents.
- b. Keep a diary or log book, recording CONTRACTOR hours on the job site, weather conditions, data relative to questions of Work Directive Changes, Change Orders or changed conditions, list of job site visitors, daily activities, decisions, observations in general, and specific observations in more detail as in the case of observing test procedures; and send copies to ENGINEER.
- c. Record names, addresses and telephone numbers of all CONTRACTORS, subcontractors and major suppliers of materials and equipment.

9. Reports:

- a. Furnish ENGINEER periodic reports as required of progress of the Work and of CONTRACTOR's compliance with the progress schedule and schedule of Shop Drawing and sample submittals.
- b. Consult with ENGINEER in advance of scheduled major tests, inspections or start of important phases of Work.
- c. Report immediately to ENGINEER and OWNER upon the occurrence of any accident.

10. Payment Requests: Review applications for payment with CONTRACTOR for compliance with the established procedure for their submission and forward with recommendations to ENGINEER, noting particularly the relationship of the payment requested to the schedule of values, work completed and materials and equipment delivered at the site but not incorporated in the Work.

11. Certificates, Maintenance and Operation Materials: During the course of the Work, verify that certificates, maintenance and operation manuals and other data required to be assembled and furnished by CONTRACTOR are

Effective February 10, 2011

applicable to the items actually installed and in accordance with the Contract Documents, and have this material delivered to ENGINEER for review and forwarding to OWNER prior to final payment for the work.

12. Completion:

- a. Before ENGINEER issues a Notice of Substantial Completion, submit to CONTRACTOR a list of observed items requiring completion or correction.
- b. Conduct final observation in the company of ENGINEER, OWNER and CONTRACTOR and prepare a final list of items to be completed or corrected.
- c. Observe that all items on final list have been completed or corrected and make recommendations to ENGINEER concerning acceptance.

C. Limitations of Authority

Resident Project Representative:

1. Shall not authorize any deviation from the Contract Documents or substitution of materials or equipment, unless authorized by ENGINEER.
2. Shall not exceed limitations of ENGINEER's authority as set forth in the Contract Documents.
3. Shall not undertake any of the responsibilities of CONTRACTOR, subcontractors or CONTRACTOR's superintendent.
4. Shall not advise on, issue directions relative to or assume control over any aspect of the means, methods, techniques, sequences or procedures of construction unless such advice or directions are specifically required by the Contract Documents.
5. Shall not advise on, issue directions regarding or assume control over safety precautions and programs in connection with the Work.
6. Shall not accept Shop Drawing or sample submittals from anyone other than CONTRACTOR.
7. Shall not authorize OWNER to occupy the Project in whole or in part.
8. Shall not participate in specialized field or laboratory tests or inspections conducted by others except as specifically authorized by ENGINEER.

SUPPLEMENTAL GENERAL CONDITIONS
FOR
CLEAN WATER STATE REVOLVING FUND
DRINKING WATER STATE REVOLVING FUND
(Drinking Water and Wastewater)

Project Name: 16-inch North Water Transmission Line – Phase I

Project Number: F15-069

The attached instructions and regulations as listed below shall be incorporated into the Specifications and comprise Special Conditions.

	<u>Attachment No.</u>
SRF Special Provisions	1
KRS Chapter 45A-Kentucky Model Procurement Code	2
Equal Employment Opportunity (EEO) Documents:	
Notice of Requirement for Affirmative Action	3
Contract Specifications (Executive Order 11246)	4
EEO Goals for Region 4 Economic Areas	5
Special Notice #1 - Check List of EEO Documentation	6
Employer Information Report EEO-1 (SF 100)	7
Labor Standards Provisions for Federally Assisted Construction, EPA Form 5720-4	8
Certifications	
Debarment, Suspension and Other Responsibility Matters	9
Anti-lobbying	10
Region 4 Disadvantaged Business Enterprise (DBE)	11
Bonds and Insurance	12
Storm Water General Permit	13
Davis-Bacon Wage Rate Requirements under FY 2013 Continuing Resolution	14

SRF SPECIAL PROVISIONS

- (a) **Line crossings of all roads and streets shall be done in accordance with the Kentucky Transportation Cabinet requirements as may be set forth in the Special Conditions.**
- (b) **Construction is to be carried out so as to prevent by-passing of flows during construction unless a schedule has been approved by the State or EPA, whichever is applicable. Siltation and soil erosion must be minimized during construction. All construction projects with surface disturbance of more than 1 acre during the period of construction must have a KPDES Storm Water General Permit. The permit can be found at the following web address: <https://dep.gateway.ky.gov/eForms/default.aspx?FormID=7>.**
If you have any questions regarding the completion of this form call the Surface Water Permits Branch at (502) 564-3410.
- (c) **Restore disturbed areas to original or better condition.**
- (d) **Use of Chemicals: All chemicals used during project construction or furnished for project operation, whether herbicide, pesticide, disinfectant, polymer, reactant or of other classification, must show approval of either DOW or EPA. Use of all such chemicals and disposal of residues shall be in conformance with instructions on the manufacturer's label.**
- (e) **The construction of the project, including the letting of contracts in connection therewith, shall conform to the applicable requirements of state, territorial, and local laws and ordinances to the extent that such requirements do not conflict with Federal laws and this subchapter.**
- (f) **The owner shall provide and maintain competent and adequate supervision and inspection.**
- (g) **The Kentucky Infrastructure Authority and Kentucky Division of Water shall have access to the site and the project work at all times.**
- (h) **In the event Archaeological materials (arrowheads, stone tools, stone axes, prehistoric and historic pottery, bottles, foundations, Civil War artifacts, and other types of artifacts) are uncovered during the construction of this project, work is to immediately cease at the location and the Kentucky Heritage Council shall be contacted. The telephone number is (502) 564-7005. Construction shall commence at this location until a written release is received from the Kentucky Heritage Council. Failure to report a find could result in legal action.**
- (i) **This procurement will be subject to DOW Procurement Guidance including the Davis-Bacon Act.**
- (j) **Reasonable care shall be taken during construction to avoid damage to vegetation. Ornamental shrubbery and tree branches shall be temporarily tied back, where appropriate, to minimize damage. Trees which receive damage to branches shall be trimmed of those branches to improve the appearance of the tree. Tree trunks receiving damage from equipment shall be treated with a tree dressing.**
- (k) **No wastewater bypassing will occur during construction unless a schedule has been approved by the Kentucky Division of Water.**
- (l) **Change orders to the construction contract (if required) must be negotiated pursuant to DOW/KIA Procurement Guidance for Construction and Equipment Contracts.**

Attachment Number 2

KRS Chapter 45A
Kentucky Model Procurement Code

45A.075 Methods of awarding state contracts.

Except as otherwise authorized by law, all state contracts shall be awarded by:

- (1) Competitive sealed bidding, pursuant to KRS 45A.080; or
- (2) Competitive negotiation, pursuant to KRS 45A.085 and 45A.090 or 45A.180; or
- (3) Noncompetitive negotiation, pursuant to KRS 45A.095; or
- (4) Small purchase procedures, pursuant to KRS 45A.100.

Effective: June 24, 2003

History: Amended 2003 Ky. Acts ch. 98, sec. 4, effective June 24, 2003. -- Created 1978 Ky. Acts ch. 110, sec. 16, effective January 1, 1979.

45A.080 Competitive sealed bidding.

(1) Contracts exceeding the amount provided by KRS 45A.100 shall be awarded by competitive sealed bidding, which may include the use of a reverse auction, unless it is determined in writing that this method is not practicable. Factors to be considered in determining whether competitive sealed bidding is not practicable shall include:

- (a) Whether specifications can be prepared that permit award on the basis of best value; and
- (b) The available sources, the time and place of performance, and other relevant circumstances as are appropriate for the use of competitive sealed bidding.

(2) The invitation for bids shall state that awards shall be made on the basis of best value. In any contract which is awarded under an invitation to bid which requires delivery by a specified date and imposes a penalty for late delivery, if the delivery is late, the contractor shall be given the opportunity to present evidence that the cause of the delay was beyond his control. If it is the opinion of the purchasing officer that there is sufficient justification for delayed delivery, the purchasing officer may adjust or waive any penalty that is provided for in the contract.

(3) Adequate public notice of the invitation for bids and any reverse auction shall be given a sufficient time prior to the date set forth for the opening of bids or beginning of the reverse auction. The notice may include posting on the Internet or publication in a newspaper or newspapers of general circulation in the state as determined by the secretary of the Finance and Administration Cabinet not less than seven (7) days before the date set for the opening of the bids and any reverse auction. The provisions of this subsection shall also apply to price contracts and purchase contracts of state institutions of higher education.

(4) Bids shall be opened publicly or entered through a reverse auction at the time and place designated in the invitation for bids. At the time the bids are opened, or the reverse auction has ended, the purchasing agency shall announce the agency's engineer's estimate, if applicable, and make it a part of the agency records pertaining to the letting of any contract for which bids were received. Each written or reverse auction bid, together with the name of the bidder and the agency's engineer's estimate, shall be recorded and be open to public inspection. Electronic bid opening and posting of the required information for public viewing shall satisfy the requirements of this subsection.

(5) The contract shall be awarded by written notice to the responsive and responsible bidder whose bid offers the best value.

(6) Correction or withdrawal of written or reverse auction bids shall be allowed only to the extent permitted by regulations issued by the secretary.

Effective: July 15, 2010

History: Amended 2010 Ky. Acts ch. 63, sec. 3, effective July 15, 2010. -- Amended 2000 Ky. Acts ch. 509, sec. 1, effective July 14, 2000. -- Amended 1998 Ky. Acts ch. 120, sec. 10, effective July 15, 1998. -- Amended 1997 (1st Extra. Sess.) Ky. Acts ch. 4, sec. 27, effective May 30, 1997. -- Amended 1996 Ky. Acts ch. 60, sec. 2, effective July 15, 1996. -- Amended 1994 Ky. Acts ch. 278, sec. 1, effective July 15, 1994. -- Amended 1982 Ky. Acts ch. 282, sec. 1, effective July 15, 1982. -- Amended 1979 (1st Extra. Sess.) Ky. Acts ch. 9, sec. 1, effective February 10, 1979. -- Created 1978 Ky. Acts ch. 110, sec. 17, effective January 1, 1979.

45A.085 Competitive negotiation.

(1) When, under administrative regulations promulgated by the secretary or under KRS 45A.180, the purchasing officer determines in writing that the use of competitive sealed bidding is not practicable, and except as provided in KRS 45A.095 and 45A.100, a contract may be awarded by competitive negotiation, which may include the use of a reverse auction.

(2) Adequate public notice of the request for proposals and any reverse auction shall be given in the same manner and circumstances as provided in KRS 45A.080(3).

(3) Contracts other than contracts for projects utilizing an alternative project delivery method under KRS 45A.180 may be competitively negotiated when it is determined in writing by the purchasing officer that the bids received by competitive sealed bidding either are unreasonable as to all or part of the requirements, or were not independently reached in open competition, and for which each competitive bidder has been notified of the intention to negotiate and is given reasonable opportunity to negotiate.

(4) Contracts for projects utilizing an alternative project delivery method shall be processed in accordance with KRS 45A.180.

(5) The request for proposals shall indicate the relative importance of price and other evaluation factors, and any reverse auction procedures.

(6) Award shall be made to the responsible and responsive offeror whose proposal is determined in writing to be the most advantageous to the Commonwealth, taking into consideration price and the evaluation factors set forth in the request for proposals and the reciprocal preference for resident bidders required under KRS 45A.494.

(7) Written or oral discussions shall be conducted with all responsible offerors who submit proposals determined in writing to be reasonably susceptible of being selected for award. Discussions shall not disclose any information derived from proposals submitted by competing offerors. Discussions need not be conducted:

(a) With respect to prices, where the prices are fixed by law, reverse auction, or administrative regulation, except that consideration shall be given to competitive terms and conditions;

(b) Where time of delivery or performance will not permit discussions; or

(c) Where it can be clearly demonstrated and documented from the existence of adequate competition or prior experience with the particular supply, service, or construction item, that acceptance of an initial offer without discussion would result in fair and reasonable best value procurement, and the request for proposals notifies all offerors of the possibility that award may be made on the basis of the initial offers.

Effective: July 15, 2010

History: Amended 2010 Ky. Acts ch. 63, sec. 4, effective July 15, 2010; and ch. 162, sec. 8, effective July 15, 2010. -- Amended 2003 Ky. Acts ch. 98, sec. 5, effective June 24, 2003. -- Amended 1997 (1st Extra. Sess.) Ky. Acts ch. 4, sec. 28, effective May 30, 1997. -- Amended 1979 (1st Extra. Sess.) Ky. Acts ch. 9, sec. 2, effective February 10, 1979. -- Created 1978 Ky. Acts ch. 110, sec. 18, effective January 1, 1979.

45A.090 Negotiation after competitive sealed bidding when all bids exceed available funds.

(1) In the event that all bids submitted pursuant to competitive sealed bidding under KRS 45A.080 result in bid prices in excess of the funds available for the purchase, and the chief purchasing officer determines in writing:

- (a) That there are no additional funds available from any source so as to permit an award to the responsive and responsible bidder whose bid offers the best value; and
- (b) The best interest of the state will not permit the delay attendant to a resolicitation under revised specifications, or for revised quantities, under competitive sealed bidding as provided in KRS 45A.080, then a negotiated award may be made as set forth in subsections (2) or (3) of this section.

(2) Where there is more than one (1) bidder, competitive negotiations pursuant to KRS 45A.085(3) shall be conducted with the three (3) (two (2) if there are only two (2)) bidders determined in writing to be the most responsive and responsible bidders, based on criteria contained in the bid invitation and the reciprocal preference for resident bidders under KRS 45A.494. Such competitive negotiations shall be conducted under the following restrictions:

- (a) If discussions pertaining to the revision of the specifications or quantities are held with any potential offeror, all other potential offerors shall be afforded an opportunity to take part in such discussions; and
- (b) A request for proposals, based upon revised specifications or quantities, shall be issued as promptly as possible, shall provide for an expeditious response to the revised requirements, and shall be awarded upon the basis of best value.

(3) Where, after competitive sealed bidding, it is determined in writing that there is only one (1) responsive and responsible bidder, a noncompetitive negotiated award may be made with such bidder in accordance with KRS 45A.095.

Effective: July 15, 2010

History: Amended 2010 Ky. Acts ch. 162, sec. 9, effective July 15, 2010. -- Amended 2003 Ky. Acts ch. 98, sec. 6, effective June 24, 2003. -- Amended 1997 (1st Extra. Sess.) Ky. Acts ch. 4, sec. 29, effective May 30, 1997. -- Created 1978 Ky. Acts ch. 110, sec. 19, effective January 1, 1979.

45A.095 Noncompetitive negotiation.

(1) A contract may be made by noncompetitive negotiation only for sole source purchases, or when competition is not feasible, as determined by the purchasing officer in writing prior to award, under administrative regulations promulgated by the secretary of the Finance and Administration Cabinet or the governing boards of universities operating under KRS Chapter 164A, or when emergency conditions exist. Sole source is a situation in which there is only one (1) known capable supplier of a commodity or service, occasioned by the unique nature of the requirement, the supplier, or market conditions. Insofar as it is practical, no less than three (3) suppliers shall be solicited to submit written or oral quotations whenever it is determined that competitive sealed bidding is not feasible. Award shall be made to the supplier offering the best value. The names of the suppliers submitting quotations and the date and amount of each quotation shall be placed in the procurement file and maintained as a public record. Competitive bids may not be required:

- (a) For contractual services where no competition exists, such as telephone service, electrical energy, and other public utility services;
- (b) Where rates are fixed by law or ordinance;
- (c) For library books;
- (d) For commercial items that are purchased for resale;
- (e) For interests in real property;
- (f) For visiting speakers, professors, expert witnesses, and performing artists;

- (g) For personal service contracts executed pursuant to KRS 45A.690 to 45A.725; and
- (h) For agricultural products in accordance with KRS 45A.645.
- (2) The chief procurement officer, the head of a using agency, or a person authorized in writing as the designee of either officer may make or authorize others to make emergency procurements when an emergency condition exists.
- (3) An emergency condition is a situation which creates a threat or impending threat to public health, welfare, or safety such as may arise by reason of fires, floods, tornadoes, other natural or man-caused disasters, epidemics, riots, enemy attack, sabotage, explosion, power failure, energy shortages, transportation emergencies, equipment failures, state or federal legislative mandates, or similar events. The existence of the emergency condition creates an immediate and serious need for services, construction, or items of tangible personal property that cannot be met through normal procurement methods and the lack of which would seriously threaten the functioning of government, the preservation or protection of property, or the health or safety of any person.
- (4) The Finance and Administration Cabinet may negotiate directly for the purchase of contractual services, supplies, materials, or equipment in bona fide emergencies regardless of estimated costs. The existence of the emergency shall be fully explained, in writing, by the head of the agency for which the purchase is to be made. The explanation shall be approved by the secretary of the Finance and Administration Cabinet and shall include the name of the vendor receiving the contract along with any other price quotations and a written determination for selection of the vendor receiving the contract. This information shall be filed with the record of all such purchases and made available to the public. Where practical, standard specifications shall be followed in making emergency purchases. In any event, every effort should be made to effect a competitively established price for purchases made by the state.

Effective: July 15, 2002

History: Amended 2002 Ky. Acts ch. 344, sec. 9, effective July 15, 2002. -- Amended 1997 (1st Extra. Sess.) Ky. Acts ch. 4, sec. 30, effective May 30, 1997. -- Amended 1990 Ky. Acts ch. 496, sec. 4, effective July 13, 1990. -- Created 1978 Ky. Acts ch. 110, sec. 20, effective January 1, 1979

45A.100 Small purchases by state governmental bodies.

- (1) Procurements may be made in accordance with small purchase administrative regulations promulgated by the secretary of the Finance and Administration Cabinet, pursuant to KRS Chapter 13A, as follows:
- (a) Up to ten thousand dollars (\$10,000) per project for construction and one thousand dollars (\$1,000) for purchases by any state governmental body, except for those state administrative bodies specified in paragraph (b) of this subsection; and
- (b) Up to forty thousand dollars (\$40,000) per project for construction or purchases by the Finance and Administration Cabinet, state institutions of higher education, and the legislative branch of government.
- (2) Procurement requirements shall not be artificially divided so as to constitute a small purchase under this section. Reverse auctions may be used for small purchase procurements. At least every two (2) years, the secretary shall review the prevailing costs of labor and materials and may make recommendations to the next regular session of the General Assembly for the revision of the then current maximum small purchase amount as justified by intervening changes in the cost of labor and materials.
- (3) The secretary of the Finance and Administration Cabinet may grant to any state agency with a justifiable need a delegation of small purchasing authority which exceeds the agency's small purchase limit provided in subsection (1) of this section. Delegations of small purchasing authority shall be granted or revoked by the secretary of the Finance and Administration Cabinet, in accordance with administrative regulations promulgated by the cabinet pursuant to KRS

Chapter 13A. These administrative regulations shall establish, at a minimum, the criteria for granting and revoking delegations of small purchasing authority, including the requesting agency's past compliance with purchasing regulations, the level of training of the agency's purchasing staff, and the extent to which the agency utilizes the Kentucky Automated Purchasing System. The administrative regulations may permit the secretary of the Finance and Administration Cabinet to delegate small purchase procurements up to the maximum amount specified in subsection (1)(b) of this section.

Effective: July 15, 2010

History: Amended 2010 Ky. Acts ch. 63, sec. 5, effective July 15, 2010. -- Amended 2002 Ky. Acts ch. 320, sec. 2, effective July 15, 2002. -- Amended 2000 Ky. Acts ch. 225, sec. 1, effective July 14, 2000. -- Amended 1996 Ky. Acts ch. 60, sec. 1, effective July 15, 1996. -- Amended 1994 Ky. Acts ch. 323, sec. 1, effective July 15, 1994. -- Amended 1990 Ky. Acts ch. 496, sec. 5, effective July 13, 1990. -- Amended 1986 Ky. Acts ch. 384, sec. 1, effective July 15, 1986. -- Amended 1984 Ky. Acts ch. 384, sec. 1, effective July 13, 1984. -- Amended 1982 Ky. Acts ch. 282, sec. 2, effective July 15, 1982. -- Amended 1980 Ky. Acts ch. 242, sec. 1, effective July 15, 1980; and ch. 250, sec. 19, effective April 9, 1980. -- Created 1978 Ky. Acts ch. 110, sec. 21, effective January 1, 1979.

Attachment Number 3

**NOTICE OF REQUIREMENT FOR AFFIRMATIVE ACTION TO ENSURE
EQUAL EMPLOYMENT OPPORTUNITY (EXECUTIVE ORDER 11246)**

The following excerpts are from 45 FR 65984 (October 3, 1980):

The minority and female goals apply to Federal and federally assisted construction contractors and subcontractors which have covered contracts. The goals are expressed as a percentage of the total hours worked by such a covered or subcontractor's entire onsite construction workforce, which is working on any construction site within a relevant area. The goal applies to each construction craft and trade in the contractor's entire workforce in the relevant area including those employees working on private non-federally involved projects.

Until further notice, the following goals for minority utilization in each construction craft and trade shall be included in all Federal or federally assisted construction contracts and subcontracts in excess of \$10,000 to be performed in the respective geographic area. The goals are applicable to each nonexempt contractor's total onsite construction workforce, regardless of whether or not part of that workforce is performing work on a Federal, federally assisted or non-federally related project, contract or subcontract.

Construction contractors which are participating in an approved Hometown Plan (see 41 CFR 60-4.5) are required to comply with the goals of the Hometown Plan with regard to construction work they perform in the area covered by the Hometown Plan. With regard to all their other covered construction work, such contractors are required to comply as follows:

- Goals for female participation in each trade.....6.9%
- Goals for minority participation in each trade.....Insert goals for each year
(see Attachment Number 6)

These goals are applicable to all the Contractor's construction work (whether or not it is Federal or Federally assisted) performed in the covered area.

The following excerpts are from 45 FR 65977 (October 3, 1980):

The Contractor's compliance with the Executive Order and the regulations in 41 CFR Part 60-4 shall be based on its implementation of the Equal Opportunity Clause, specific affirmative action obligations required by the specifications set forth in 41 CFR 60-4.3(a), and its efforts to meet the goals established for the geographical area where the contract resulting from this solicitation is to be performed. The hours of minority and female employment and training must be substantially uniform throughout the length of the contract, and in each trade, and the contractor shall make a good faith effort to employ minorities and women evenly on each of its projects. The transfer of minority or female employees or trainees from Contractor to Contractor or from project to project for the sole purpose of meeting the Contractor's goals shall be a violation of the contract, the Executive Order and the regulations in 41 CFR Part 60-4. Compliance with the goals will be measured against the total work hours performed.

3. The Contractor shall provide written notification to the Director of the Office of Federal Contract Compliance Programs within 10 working days of award of any construction subcontract in excess of \$10,000 at any tier for construction work under the contract resulting from this solicitation. The notification shall list the name, address and telephone number of the subcontractor; employer identification number; estimated dollar amount of the subcontract; estimated starting and completion dates of the subcontract; and the geographical area in which the contract is to be performed.

4. As used in this Notice, and in the contract resulting from this solicitation, the covered area is (insert description of the geographical areas where the contract is to be performed giving the state, country, and city, if any).

Attachment Number 4

**STANDARD FEDERAL EQUAL EMPLOYMENT OPPORTUNITY CONSTRUCTION
CONTRACT SPECIFICATIONS (EXECUTIVE ORDER 11246)**

EEO Specifications

Following is the standard language, which must be incorporated into all solicitations for offers and bids on all Federal and Federally assisted construction contracts or subcontracts in excess of \$10,000 to be performed in designated geographical areas:

1. As used in these specifications:

- (a) Covered Area means the geographical area described in the solicitation from which this contract resulted.
- (b) Director means Director, Office of Federal Contract Compliance Program, United States Department of Labor, or any person to whom the Director delegates authority;
- (c) Employer identification number means the Federal Social Security number used on the Employer's Quarterly Federal Tax Return, U.S. Treasury Department Form 941.
- (d) Minority includes:
 - (i) Black (all persons having origins in any of the Black African racial groups not of Hispanic origin);
 - (ii) Hispanic (all persons of Mexican, Puerto Rican, Cuban, Central or South American or other Spanish Culture or origin, regardless of race);
 - (iii) Asian and Pacific Islander (all persons having origins in any of the original peoples of the Far East, Southeast Asia, the Indian Subcontinent, or the Pacific Islands); and
 - (iv) American Indian or Alaskan Native (all persons having origins in any of the original peoples of North America and maintaining identifiable tribal affiliations through membership and participation or community identification).

2. Whenever the Contractor or any Subcontractor at any tier, subcontracts a portion of the work involving any construction trade, it shall physically include in each subcontract in excess of \$10,000 the provisions of these specifications and the Notice which contains the applicable goals for minority and female participation and which is set forth in the solicitations from which this contract resulted.

3. If the Contractor is participating (pursuant to 41 CFR 60-4.5) in a Hometown Plan approved by the U.S. Department of Labor in the covered area either individually or through an association, its affirmative action obligations on all work in the Plan area (including goals and timetables) shall be in accordance with that Plan for those trades which have unions participating in the Plan. Contractors must be able to demonstrate their participation in and compliance with the provisions of any such Hometown Plan. Each Contractor or Subcontractor participating in an approved Plan is individually required to comply with its obligations under the EEO clause, and to make a good faith effort to achieve each goal under the Plan in each trade in which it has employees. The overall good faith performance by other Contractors or Subcontractors toward a goal in an approved Plan does not excuse any covered Contractor's or Subcontractor's failure to take a good faith efforts to achieve the Plan goals and timetables.

4. The Contractor shall implement the specific affirmative action standards provided in paragraphs 7-a through p of these specifications. The goals set forth in the solicitation from which this contract resulted are expressed as percentages of the total hours of employment and training of minority and female utilization the Contractor should reasonably be able to achieve in each construction trade in which it has employees in the covered area. The Contractor is expected to make substantially uniform progress toward its goals in each craft during the period specified.

5. Neither the provisions of any collective bargaining agreement, nor the failure by a union with whom the Contractor has a collective bargaining agreement, to refer either minorities or women shall excuse the Contractor's obligations under these specifications, Executive Order 11246, or the regulations promulgated pursuant thereto.

6. In order for the non-working training hours of apprentices and trainees to be counted in meeting the goals, such apprentices and trainees must be employed by the contractor during the training period, and the Contractor must have made a commitment to employ the apprentices and trainees at the completion of their training, subject to the availability of employment opportunities. Trainees must be trained pursuant to training programs approved by the U.S. Department of Labor.

7. The Contractor shall take specific affirmative action to ensure equal employment opportunity. The evaluation of the Contractor's compliance with these specifications shall be based upon its effort to achieve maximum results from its actions. The Contractor shall document these efforts fully, and shall implement affirmative actions steps at least as extensively as the following:

- a. Ensure and maintain a working environment free of harassment, intimidation, and coercion at all sites, and in all facilities at which the contractor's employees are assigned to work. The Contractor, where possible, will assign two or more women to each construction project. The Contractor shall specifically ensure that all foremen, superintendents, and other on-site supervisory personnel are aware of and carry out the Contractor's obligation to maintain such a working environment, with specific attention to minority or female individuals working at such sites or in such facilities.
- b. Establish and maintain a current list of minority and female recruitment sources, provide written notification to minority and female recruitment sources and to community organizations when the contractor or its unions have employment opportunities available, and maintain a record of the organizations responses.
- c. Maintain a current file of the names, addresses and telephone numbers of each minority and female off-the-street applicant and minority or female referral from a union, a recruitment source or community organization and of what action was taken with respect to each such individual. If such individual was sent to the union hiring hall for referral and was not referred back to the Contractor by the union or, if referred, not employed by the contractor, this shall be documented in the file with the reason therefore, along with whatever additional actions the contractor may have taken.
- d. Provide immediate written notification to the Director when the union or unions with which the Contractor has a collective bargaining agreement has not referred to the Contractor a minority person or woman sent by the Contractor, or when the Contractor has other information that the union referral process has impeded the Contractor's efforts to meet its obligation.
- e. Develop on-the-job training opportunities and/or participate in training programs for the area which expressly include minorities and women, including upgrading programs and apprenticeship and trainee programs relevant to the Contractor's employment needs, especially those programs funded or approved by the Department of Labor. The Contractor shall provide notice of these programs to the sources complied under 7-b above.

f. Disseminate the Contractor's EEO policy by providing notice of the policy to unions and training programs and requesting their cooperation in assisting the Contractor in meeting its EEO obligations; by including it in any policy manual and collective bargaining agreement; by publicizing it in the company newspaper, annual report, etc.; by specific review of the policy with all management personnel and with all minority and female employees at least once a year; and by posting the company EEO policy on bulletin boards accessible to all employees at each location where construction work is performed.

g. Review, at least annually, the company's EEO policy and affirmative action obligations under these specifications with all employees having any responsibility for hiring, assignment, lay-off, termination or other employment decisions including specific review of these items with on-site supervisory personnel such as Superintendents, General Foreman, etc., prior to the initiation of construction work at any job site. A written record shall be made and maintained identifying the time and place of these meetings, persons attending, subject matter discussed, and disposition of the subject matter.

h. Disseminate the Contractor's EEO policy externally by including it in any advertising in the news media, specifically including minority and female news media, and providing written notification to and discussing the Contractor's EEO policy with other Contractors and Subcontractors with whom the Contractor does or anticipates doing business.

i. Direct its recruitment efforts, both oral and written, to minority, female and community organizations, to schools with minority and female students and to minority and female recruitment and training organizations serving the Contractor's recruitment area and employment needs. Not later than one month prior to the date for the acceptance of applications for apprenticeship or other training by any recruitment source, the contractor shall send written notification to organizations such as the above, describing the openings, screening procedures, and tests to be used in the selection process.

j. Encourage present minority and female employees to recruit other minority persons and women and, where reasonable, provide after school, summer and vacation employment to minority and female youth both on the site and in other areas of a Contractor's workforce.

k. Validate all tests and other selection requirements where there is an obligation to do so under 41 CFR Part 60-3.

l. Conduct, at least annually, an inventory and evaluation of all minority and female personnel for promotional opportunities and encourage these employees to seek or to prepare for, through appropriate training, etc., such opportunities.

m. Ensure that seniority practices, job classifications, work assignments and other personnel practices, do not have a discriminatory effect by continually monitoring all personnel and employment related activities to ensure that EEO policy and the Contractor's obligations under these specifications are being carried out.

n. Ensure that all facilities and company activities are nonsegregated except that separate or single-user toilet and necessary changing facilities shall be provided to assure privacy between the sexes.

o. Document and maintain a record of all solicitations of offers for subcontracts from minority and female construction contractors and suppliers, including circulation of solicitations to minority and female contractor associations and other business associations.

p. Conduct a review, at least annually, of all supervisor's adherence to and performance under the Contractor's EEO policies and affirmative action obligations.

8. Contractors are encouraged to participate in voluntary associations, which assist in fulfilling one or more of their affirmative actions obligations (7 a through p). The efforts of a contractor association, joint contractor-union, contractor-community, or other similar group of which the contractor is a member and participant may be asserted as fulfilling any one or more of its obligations under 7 a through p of these specifications provided that the contractor actively participates in the group, makes every effort to assure that the group has a positive impact on the employment of minorities and women in the industry, ensures that the concrete benefits of the program are reflected in the Contractor's minority and female workforce participation, makes a good faith effort to meet its individual goals and timetables, and can provide access to documentation which demonstrates the effectiveness of actions taken on behalf of the Contractor. The obligation to comply, however, is the Contractor's and failure of such a group to fulfill an obligation shall not be defense for the Contractor's noncompliance.

9. A single goal for minorities and a separate single goal for women have been established. The contractor, however, is required to provide equal employment opportunity and to take affirmative action for all minority groups, both male and female, and all women, both minority and non-minority. Consequently, the Contractor may be in violation of the Executive Order if a particular group is employed in a substantially disparate manner (for example: even though the Contractor has achieved its goal for women generally, the Contractor may be in violation of the Executive Order if a specific minority group of women is underutilized).

10. The Contractor shall not use the goals and timetables for affirmative action standards to discriminate against any person because of race, color, religion, sex or national origin.

11. The Contractor shall not enter into any Subcontract with any person or firm debarred from Government contracts pursuant to Executive Order 11246.

12. The Contractor shall carry out such sanctions and penalties for violation of these specifications and of the Equal Opportunity Clause, including suspension, termination and cancellation of existing subcontracts as may be imposed or ordered pursuant to Executive Order 11246, as amended, and its implementing regulations, by the Office of Federal Contract Compliance Programs. Any Contractor who fails to carry out such sanctions and penalties shall be in violation of these specifications and executive Order 11246, as amended.

13. The Contractor, in fulfilling its obligations under these specifications, shall implement specific affirmative action steps, at least as extensive as those standards prescribed in paragraph 7 of these specifications, so as to achieve maximum results from its efforts to ensure equal employment opportunity. If the Contractor fails to comply with the requirements of the Executive Order, the implementing regulations, or these specifications, the Director shall proceed in accordance with 41 CFR 60-4.8.

14. The Contractor shall designate a responsible official to monitor all employment related activity to ensure that the company EEO policy is being carried out, to submit reports relating to the provisions hereof as may be required by the Government and to keep records. Records shall at least include for each employee the name, address, telephone numbers, construction trade, union affiliation, if any, employee identification number when assigned, social security number, race, sex, status (e.g., mechanic, apprentice, trainee, helper or laborer), dates of changes in status, hours worked per week in the indicated trade, rate of pay, and locations at which the work was performed. Records shall be maintained in an easily understandable and retrievable form; however, to the degree that existing records satisfy this requirement, contractors shall not be required to maintain separate records.

15. Nothing herein provided shall be construed as a limitation upon the application of other laws which establish different standards of compliance or upon the application of requirements for the hiring of local

or other area residents (e.g., those under the Public Works Employment Act of 1977 and the Community Development Block Grant Program).

Attachment Number 5

EEO Goals for Economic Areas in Region 4

Source: Appendix B-80 in 45 FR 65984 (October 3, 1980)

Kentucky:

053 Knoxville, TN	
SMSA Counties:	
3840 Knoxville, TN	6.6
TN Anderson; TN Blount; TN Knox; TN Union.	
Non-SMSA Counties	4.5
KY Bell; KY Harlan; KY Knox; KY Laurel; KY McCreary; KY Wayne; KY Whitley; TN	
Campbell; TN Claiborne; TN Cocke; TN Cumberland; TN Fentress; TN Grainger, TN Hamblen;	
TN Jefferson; TN Loudon; TN Morgan; TN Roane; TN Scott;	
TN Sevier.	
054 Nashville, TN:	
SMSA Counties:	
1660 Clarksville - Hopkinsville, TN - KY	18.2
KY Christian; TN Montgomery.	
5360 Nashville - Davidson, TN	15.8
TN Cheatham, TN Davidson; TN Dickson; TN Robertson; TN Rutherford; TN Sumner; TN	
Williamson; TN Wilson.	
Non-SMSA Counties	12.0
KY Allen; KY Barren; KY Butler; KY Clinton; KY Cumberland; KY Edmonson; KY Logan; KY	
Metcalf; KY Monroe; KY Simpson; KY Todd; KY Trigg; KY Warren; TN Bedford; TN Cannon;	
TN Clay; TN Coffee; TN DeKalb; TN Franklin; TN Giles; TN Hickman; TN Houston; TN	
Humphreys; TN Jackson; TN Lawrence; TN Lewis; TN Macon; TN Marshall; TN Maury; TN	
Moore; TN Overton; TN Perry; TN Pickett; TN Putnam; TN Smith; TN Stewart; TN Trousdale;	
TN Van Buren; TN Warren; TN Wayne; TN White.	
056 Paducah, KY:	
Non-SMSA Counties	5.2
IL Hardin; IL Massac; IL Pope; KY Ballard; KY Caldwell; KY Calloway. KY Carlisle; KY	
Crittenden; KY Fulton; KY Graves; KY Hickman; KY Livingston; KY Lyon. KY McCracken; KY	
Marshall.	
057 Louisville, KY:	
SMSA Counties:	
4520 Louisville, KY-IN	11.2
IN Clark; IN Floyd; KY Bullitt; KY Jefferson; KY Oldham.	
Non-SMSA Counties	9.6
IN Crawford; IN Harrison; IN Jefferson; IN Orange; IN Scott; IN Washington; KY Breckinridge;	
KY Grayson; KY Hardin; KY Hart; KY Henry; KY Larue; KY Marion;	
KY Meade; KY Nelson; KY Shelby; KY Spencer; KY Trimble; KY Washington.	
058 Lexington, KY	
SMSA Counties	
4280 Lexington-Fayette, KY	10.8
KY Bourbon; KY Clark; KY Fayette; KY Jessamine; KY Scott; KY Woodford.	
Non-SMSA Counties	7.0
KY Adair KY Anderson; KY Bath; KY Boyle; KY Breathitt; KY Casey; KY Clay; KY Estill; KY	
Franklin; KY Garrard; KY Green; KY Harrison; KY Jackson; KY Knott; KY Lee; KY Leslie; KY	
Letcher; KY Lincoln; KY Madison; KY Magoffin; KY Menifee; KY Mercer; KY Montgomery;	
KY Morgan. KY Nicholas; KY Owsley; KY Perry; KY Powell; KY Pulaski; KY Rockcastle; KY	
Russell; KY Taylor; KY Wolfe.	
059 Huntington, WV:	
SMSA Counties:	
3400 Huntington - Ashland, WV-KY-OH	2.9
KY Boyd; KY Greenup; OH Lawrence; WV Cabell; WV Wayne.	
Non-SMSA Counties	2.5
KY Carter; KY Elliott; KY Floyd; KY Johnson; KY Lawrence; KY Martin; KY Pike; KY Rowan;	
OH Gallia; WV Lincoln; WV Logan; WV Mason; WV Mingo.	
067 Cincinnati, OH:	
SMSA Counties:	
1640 Cincinnati, OH-KY-IN	11.0
IN Dearborn; KY Boone; KY Campbell; KY Kenton; OH Clermont;	
OH Hamilton; OH Warren.	

3200 Hamilton-Middletown, OH	5.0
OH Butler.	
Non-SMSA Counties	9.2
IN Franklin; IN Ohio; IN Ripley; IN Switzerland; KY Bracken; KY Carroll; KY Fleming; KY Gallatin; KY Grant; KY Lewis; KY Mason; KY Owen; KY Pendleton; KY Robertson; OH Adams; OH Brown; OH Clinton; OH Highland.	
080 Evansville, IN:	
SMSA Counties	
2440 Evansville, IN-KY	4.8
IN Gibson; IN Posey; IN Vanderburgh; IN Warrick; KY Henderson.	
5990 Owensboro, KY	4.7
KY Daviess.	
Non-SMSA Counties	3.5
IL Edwards; IL Gallatin; IL Hamilton; IL Lawrence; IL Saline; IL Wabash; IL White; IN Dubois; IN Knox; IN Perry; IN Pike; IN Spencer; KY Hancock; KY Hopkins; KY McLean; KY Muhlenberg; KY Ohio; KY Union; KY Webster.	

Attachment Number 6

**CHECK LIST OF EEO DOCUMENTATION FOR BIDDERS
ON GRANT/LOAN CONSTRUCTION
(Required by Executive Order 11246 as amended)**

The low, responsive responsible bidder must forward the following items, in duplicate, to the owner no later than ten (10) days after bid opening. The owner shall have one (1) copy available for inspection by the Office of Federal Contracts Compliance within 14 days after the bid opening. The web site for the OFCC is http://www.dol.gov/esa/ofcp_org.htm.

1. Project Number. Project Location. Type of Construction.
2. Proof of registration with the Joint Reporting Commission. (See Attachment Number 8.)
3. Copy of Affirmative Action Plan of contractor. Indicate company official responsible for EEO.
4. List of current construction contracts, with dollar amount. List contracting Federal Agency, if applicable.
5. Statistics concerning company percent workforce, permanent and temporary, by sex, race, trade, handicapped, and age. 40 CFR Part 7.
6. List of employment sources for project in question. If union sources are utilized, indicate percentage of minority membership within the union crafts.
7. Anticipated employment needs for this project, by sex, race and trade, with estimate of minority participation in specific trades.
8. List of subcontractors (name, address and telephone) with dollar amount and duration of subcontract. Subcontractor contracts over \$10,000 must submit items 1- 8. The following information must be provided for all supplier contracts regardless of contract size: name of company, contact person, address, telephone number, dollar value of the contract, and a list of the materials to be supplied to the prime contractor.
9. List of any subcontract work yet to be committed with estimate of dollar amount and duration of contract.
10. Contract Price. Duration of prime contract.
11. DBE Documents - See special instructions regarding use of Minority, and Women Owned, and Small Businesses.

Employer Information Report EEO-1

Under the direction of the US Equal Employment Opportunity Commission, the Joint Reporting Committee is responsible for the full-length, multi-phase processing of employment statistics collected on the Employer Information Report EEO-1. This report, also termed Standard Form 100, details the sex and race/ethnic composition of an employer's work force by job category.

The Employer Information EEO-1 survey is conducted annually under the authority of Public Law 88-352, Title VII of the Civil Rights Act of 1964, as amended by the Equal Employment Opportunity Act of 1972. All employers with 15 or more employees are covered by Public Law 88-352 and are required to keep employment records as specified by Commission regulations. Based on the number of employees and federal contract activities, certain large employers are required to file an EEO-1 Report on an annual basis.

The EEO-1 Report must be filed by:

(A) All private employers who are: (1) subject to Title VII of the Civil Rights Act of 1964 (as amended by the Equal Employment Opportunity Act of 1972) with 100 or more employees EXCLUDING State and local governments, primary and secondary school systems, institutions of higher education, Indian tribes and tax-exempt private memberships clubs other than labor organizations; OR (2) subject to Title VII who have fewer than 100 employees if the company is owned or affiliated with another company, or there is centralized ownership, control or management (such as central control of personnel policies and labor relations) so that the group legally constitutes a single enterprise and the entire enterprise employs a total of 100 or more employees.

(B) All federal contractors (private employers), who: (1) are not exempt as provided for by 41 CFR 60-1.5, (2) have 50 or more employees, and (a) are prime contractors or first-tier subcontractors, and have a contract, subcontract, or purchase order amounting to \$50,000 or more; or (b) serve as depository of Government funds in any amount, or (c) is a financial institution which is an issuing an paying agent for U.S. Savings Bonds and Notes.

Only those establishments located in the District of Columbia and the 50 states are required to submit the EEO-1 Report. No Reports should be filed for establishments in Puerto Rico, the Virgin Islands or other American Protectorates.

When filing for the EEO-1 Report for the first time, go to the web site at:

<http://www.mimdms.com/jrc.html> and select "Filing for the first time" from the box labeled INFORMATION. File out the electronic questionnaire to enter your company into Joint Reporting Committee (JRC) system. Once you have completed the registration process, you will be contacted on how to proceed with the EEO-1 Report. If you have previously registered with the JRC, follow their instructions to update your information.

Labor Standards Provisions for Federally Assisted Construction

Labor standards provisions applicable to contracts covering federally financed and assisted construction (29 CFR 5.5, Contract Provisions and Related Matters) that apply to EPA Special Appropriations Projects grants are:

(a)(4)(iii) Equal employment opportunity. The utilization of apprentices, trainees and journeymen under this part shall be in conformity with the equal employment opportunity requirements of Executive Order 11246, as amended, and 29 CFR Part 30.

(a)(5) Compliance with Copeland Act requirements. The contractor shall comply with the requirements of 29 CFR Part 3, which are incorporated by reference in this contract.

(a)(6) Subcontracts. The contractor or subcontractor shall insert in any subcontracts the clauses contained in 29 CFR 5.5 (a) (1) through (10) and such other clauses as the U.S. Environmental Protection Agency may by appropriate instructions require, and also a clause requiring the subcontractors to include these clauses in any lower tier subcontracts. The prime contractor shall be responsible for the compliance by any subcontractor or lower tier subcontractor with all the contract clauses in 29 CFR 5.5.

(a)(7) Contract termination: debarment. A breach of the contract clauses in 29 CFR 5.5 may be grounds for termination of the contract, and debarment as a contractor and a subcontractor as provided in 29 CFR 5.12.

(b) Contractor Work Hours and Safety Standards Act. The Administrator, EPA shall cause or require the contracting officer to insert the following clauses set forth in paragraph (b)(1),(2),(3), and (4) of this section in full in any contract subject to the overtime provisions of the Contract Work Hours and Safety Standards Act. These clauses shall be inserted in addition to the clauses required by *Section 5.5(a) of this title. As used in this paragraph, the terms laborers and mechanics include watchmen and guards.

(1) Overtime requirements. No contractor or subcontractor contracting for any part of the contract work which may require or involve the employment of laborers or mechanics shall require or permit any such laborer or mechanic in any work week in which he or she is employed on such work to in excess of forty hours in such workweek unless such laborer or mechanic receives compensation at a rate not less than one and one-half times the basic rate of pay for all hours worked in excess of forty hours in such workweek.

(2) Violation; liability for unpaid wages; liquidated damages. In the event of any violation of the clause set forth in paragraph (b) (1) of this section the contractor and any subcontractor responsible therefore shall be liable for the unpaid wages. In addition, such contractor and subcontractor shall be liable to the United States (in the case of work done under contract for the District of Columbia or a territory, to such District or to such territory), for unliquidated damages. Such liquidated damages shall be computed with respect to each individual laborer or mechanic, including watchmen and guards, employed in violation of the clause set forth in paragraph (b)(1) of this section, in the sum of \$10 for each calendar day on which such individual was required or permitted to work in excess of the standard workweek of forty hours without payment of the overtime wages required by the clause set forth in paragraph (b)(1) of this section.

(3) Withholding for unpaid wages and liquidated damages. The U.S. Environmental Protection Agency shall upon its own action or upon written request of an authorized representative of the Department of Labor withhold or cause to be withheld, from any moneys payable on account of work performed by the contractor or subcontractor under any such contract or any other Federal contract with the same prime contractor, or any other Federally- assisted contract subject to the Contract Work Hours and Safety Standards Act, which is held by the same prime contractor, such liabilities of such contractor or

subcontractor for unpaid wages and liquidated damages as provided in the clause set forth in paragraph (b) (2) of this section.

(4) Subcontracts. The contractor or subcontractor shall insert in any subcontracts the clauses set forth in paragraph (b)(1) through (4) of this section and also a clause requiring the subcontractors to include these clauses in any lower tier subcontracts. The prime contractor shall be responsible for compliance by any subcontractor or lower tier subcontractor with the clauses set forth in paragraphs (b)(1) through (4) of this section.

(c) In addition to the clauses contained in paragraph (b), in any contract subject only to the Contract Work Hours and Safety Standards Act and not to any of the other statutes cited in section 5.1, the Administrator of EPA shall cause or require the contracting officer to insert a clause requiring that the contractor or subcontractor shall maintain payrolls and basic payroll records during the course of the work and shall preserve them for a period of three years from the completion of the contract for all laborers and mechanics, including guards and watchmen, working on the contract. Such records shall contain the name and address of each such employee, social security number, correct classifications, hourly worked, deductions made, and actual wages paid. Further, the Administrator of EPA shall cause or require the contracting officer to insert in any such contract a clause providing that the records to be maintained under this paragraph shall be made available by the contractor or subcontractor for inspection, copying, or transcription by authorized representatives of the U.S. Environmental Protection Agency and the Department of Labor, and the contractor or subcontractor will permit such representatives to interview employees during working hours on the job. (Approved by the Office of Management and Budget under OMB control numbers 1215-0140 and 1215-0017.)

CERTIFICATIONS

Debarred Firms

All prime Construction Contractors shall certify that Subcontractors have not and will not be awarded to any firm that is currently on the EPA Master List of Debarred, Suspended and Voluntarily Excluded Persons in accordance with the provisions of 40 CFR 32.500(c). Debarment action is taken against a firm for noncompliance with Federal Law.

All bidders shall complete the attached certification (Attachment Number 10) and submit to the owner with the bid proposal.

Anti-lobbying Certification

All prime Construction Contractors must certify (Attachment Number 11) that no appropriated funds were or will be expended for the purpose of lobbying the Executive or Legislative Branches of the Federal Government or Federal Agency concerning this contract (contract in excess of \$100,000). If the Contractor has made or agreed to make payment to influence any member of Congress in regard to award of this contract, a Disclosure Form must be completed and submitted to the owner with the bid proposal.

All prime Contractors must require all Subcontractors to submit the certification, which must also be submitted to the owner.

**CERTIFICATION REGARDING DEBARMENT,
SUSPENSION AND OTHER RESPONSIBILITY MATTERS**

The prospective participant certifies to the best of its knowledge and belief that it and its principals:

- (a) Are not presently debarred, suspended, proposed for debarment, declared ineligible, or voluntarily excluded from covered transactions by any Federal department or agency;
- (b) Have not within a three year period preceding this proposal been convicted of or had a civil judgment rendered against them for commission of fraud or a criminal offense in connection with obtaining, attempting to obtain, or performing a public (Federal, State, or local) transaction or contract under a public transaction; violation of Federal or State antitrust statutes or commission of embezzlement, theft, forgery, bribery, falsification or destruction of records, making false statements, or receiving stolen property;
- (c) Are not presently indicted for or otherwise criminally or civilly charged by a government entity (Federal, State, or Local) with commission of any of the offenses enumerated in paragraph (1)(b) of this certification; and
- (d) Have not within a three-year period preceding this application/proposal had one or more public transactions (Federal, State, or local) terminated for cause or default.

I understand that a false statement on this certification may be grounds for rejection of this proposal or termination of the award. In addition, under 18 USC Sec. 1001, a false statement may result in a fine of up to \$10,000 or imprisonment for up to 5 years, or both.

Typed Name & Title of Authorized Representative

Signature of Authorized Representative

Date

_____ I am unable to certify to the above statements. My explanation is attached.

Attachment Number 10

CERTIFICATION REGARDING LOBBYING
Certification for Contracts, Grants,
Loans, and Cooperative Agreements

The undersigned certifies, to the best of his or her knowledge and belief, that:

(1) No Federal appropriated funds have been paid or will be paid, by or on behalf of the undersigned, to any person for influencing or attempting to influence an officer or employee of an agency, a Member of Congress, an officer or employee of Congress, or an employee of a Member of Congress in connection with the awarding of any Federal contract, the making of any Federal grant, the making of any Federal loan, the entering into of any cooperative agreement, and the extension, continuation, renewal, amendment, or modification of any Federal contract, grant, loan, or cooperative agreement.

(2) If any funds other than Federal appropriated funds have been paid or will be paid to any person for influencing or attempting to influence an officer or employee of any agency, a Member of Congress, an officer or employee of Congress, or an employee of a Member of Congress in connection with this Federal contract, grant, loan, or cooperative agreement, the undersigned shall complete and submit Standard Form-LLL, "Disclosure Form to Report Lobbying," in accordance with its instructions.

(3) The undersigned shall require that the language of this certification be included in the award documents for all sub-awards at all tiers (including subcontracts, sub-grants, and contracts under grants, loans, and cooperative agreements) and that all sub-recipients shall certify and disclose accordingly.

This certification is a material representation of fact upon which reliance was placed when this transaction was made or entered into. Submission of this certification is a prerequisite for making or entering into this transaction imposed by section 1352, title 31, U.S. Code. Any person who fails to file the required certification shall be subject to a civil penalty of not less than \$10,000 and not more than \$100,000 for each such failure.

Typed Name & Title of Authorized Representative

Signature of Authorized Representative

Date

_____ I am unable to certify to the above statements. My explanation is attached.

Attachment Number 11

EPA DISADVANTAGED BUSINESS ENTERPRISE PROGRAM

EPA's Disadvantaged Business Enterprise Program rule applies to contract procurement actions funded in part by EPA assistance agreements awarded after May 27, 2008. The rule is found at Federal regulation Title 40, Part 33. Specific responsibilities are highlighted below.

Grant recipient responsibilities:

- Conduct an Availability Analysis and negotiate fair share objectives with EPA (§33.411), or adopt the fair share objectives of the oversight state agency revolving loan fund for comparable infrastructure. (§33.405(b)(3)).
- Include the Appendix A term and condition in each contract with a primary contractor (§3.106). The term and condition is included in the EPA Region 4 contract specifications insert *FEDERAL REQUIREMENTS AND CONTRACT PROVISIONS FOR SPECIAL APPROPRIATION ACT PROJECTS US ENVIRONMENTAL PROTECTION AGENCY, Region III, June 2008*.
- Employ the six Good Faith Efforts during prime contractor procurement (§33.301).
- Require prime contractor to comply with the following prime contractor requirements of Title 40 Part 33:
 - To employ the six Good Faith Efforts steps in paragraphs (a) through (e) of §33.301 if the prime contractor awards subcontracts (§33.301(f)).
 - To provide EPA form 6100-2 – *DBE Subcontractor Participation Form* to all DBE subcontractors (§33.302(e)).
 - To submit EPA forms 6100-3 – *DBE Program Subcontractor Performance Form* and 6100-4 – *DBE Program Subcontractor Utilization Form* with bid package or proposal. (§33.302 (f) and (g)).
 - To pay its subcontractor for satisfactory performance no more than 30 days from the prime contractor's receipt of payment from the recipient (§33.302(a)).
 - To notify recipient in writing by its prime contractor prior to any termination of a DBE subcontractor for convenience by the prime contractor (§33.302(b)).
 - To employ the six good faith efforts described in §33.301 if soliciting a replacement subcontractor after a DBE subcontractor fails to complete work under the subcontract for any reason. (§33.302(c)).
 - To employ the six good faith efforts described in §33.301 even if the prime contractor has achieved its fair share objectives under subpart D of Part 33. (§33.302(d)).

- Semiannually complete and submit to Charles Hayes, EPA Region 4 DBE Coordinator EPA form 5700-52A summarizing DBE participation achieved during the previous six months (§33.502).
- Maintain records documenting its compliance with the requirements of Title 40 Part 33, including documentation of its, and its prime contractors', good faith efforts (§33.501(a)).

Prime Contractor Responsibilities:

- Employ the six Good Faith Efforts steps in paragraphs (a) through (e) of §33.301 if the prime contractor awards subcontracts (§33.301(f)).
- Provide EPA form number 6100-2 – *DBE Program Subcontractor Participation Form* and form number 6100-3 – *DBE Program Subcontractor Performance Form* to each DBE subcontractor prior to opening of the contractor's bid or proposal (§33.302(e) and (f)).
- Complete EPA form number 6100-4 – *DBE Program Subcontractor Utilization Form* (§33.302(g)).
- Submit to recipient with its bid package or proposal the completed EPA form number 6100-4, plus an EPA form number 6100-3 for each DBE subcontractor used in the contractor's bid or proposal (§33.302(f) and (g)).
- Pay subcontractors for satisfactory performance no more than 30 days from the prime contractor's receipt of payment from the recipient (§33.302(a)).
- Notify the recipient in writing prior to prime contractor termination of a DBE subcontractor for convenience (§33.302(b)).
- Employ the six good faith efforts described in §33.301 if soliciting a replacement subcontractor after a DBE subcontractor fails to complete work under the subcontract for any reason. (§33.302(c)).
- Employ the six good faith efforts described in §33.301 even if the prime contractor has achieved its fair share objectives under subpart D of Part 33. (§33.302(d)).
- Semiannually inform recipient of DBE participation achieved (§33.502).
- Maintain records documenting its compliance with the requirements of Title 40 Part 33, including documentation of its, and its prime contractors', good faith efforts (§33.501(a)).

Subcontractor Responsibilities:

- May submit EPA form 6100-2 – *DBE Subcontractor Participation Form* to Charles Hayes, EPA Region 4 DBE Coordinator (§33.302(e)).
- Must complete EPA form 6100-3 – *DBE Program Subcontractor Performance Form*, and submit it to the prime contractor soliciting services from the subcontractor prior to the opening of bids for the prime contract.

SPAP Requirements:

Form	Requirement	Provided By:	Completed By:	Submitted To:
EPA Form 6100-2	Grant Recipients required to have prime contractors provide form to Subcontractors	Prime Contractors	DBE Subcontractors	EPA Region 4 DBE Coordinator Charles Hayes
EPA Form 6100-3	Grant Recipients required to have prime contractors provide form to Subcontractors	Prime Contractors	DBE Subcontractors	Grant Recipients as part of a bid or proposal package
EPA Form 6100-4	Grant Recipients required to have prime contractors complete the form	Grant Recipients	Prime Contractors	Grant Recipients as part of a bid or proposal package

SRF Requirements:

Form	Requirement	Provided By:	Completed By:	Submitted To:
EPA Form 6100-2	Recipients required to have prime contractors provide form to Subcontractors	Prime Contractors	DBE Subcontractors	DOW Project Administrator
EPA Form 6100-3	Recipients required to have prime contractors provide form to Subcontractors	Prime Contractors	DBE Subcontractors	Dow Project Administrator w/ATA Package
EPA Form 6100-4	Recipients required to have prime contractors complete the form	Recipients	Prime Contractors	DOW Project Administrator w/ATA Package
Pay Request DBE Form	Recipients required to have prime contractors complete the form	Recipients	Prime Contractors	DOW Project Administrator w/EACH PAYMENT

DISADVANTAGED BUSINESS ENTERPRISE PARTICIPATION POLICY

PROJECT NAME: _____

BID DATE: _____

1. Name, address and telephone number of contact person on all DBE matters:

Prime Contractor's Name: _____

Contact Person: _____

Address: _____

Phone: _____

Cell Phone: _____

Email: _____

Total Contract Amount: _____

2. Total dollar amount/percent of contract of MBE participation: _____

3. Total dollar amount/percent of contract of WBE participation: _____

4. Are certifications* for each MBE/WBE/DBE subcontractor enclosed; if no, please explain: _____ Yes No

5. Are MBE/WBE/DBE subcontracts or letters of intent signed by both parties enclosed; if no, please explain: _____ Yes No

6. List of MBE Subcontractors:

Name: _____

Contact Person: _____

Address: _____

Phone: _____

Cell Phone: _____

Email: _____

Type of Contract: _____

Work to be Done: _____

Amount: _____

7. List of WBE Subcontractors:

Name: _____

Contact Person: _____

Address: _____

Phone: _____

Cell Phone: _____

Email: _____

Type of Contract: _____

Work to be Done: _____

Amount: _____

Attach Additional Sheets, If Necessary

*Self-certification: Self certification of MBE/WBE/DBE firms will NOT be accepted as a valid form of certification of MBE/WBE/DBE status.

8. Information and documentation concerning efforts taken to comply with EPA's "six good faith efforts"

- (i). Ensure DBE construction firms or material suppliers are made aware of contracting opportunities to the fullest extent practicable through outreach and recruitment activities; including placing DBEs on solicitation lists and soliciting them whenever they are potential sources. A good source for a list of DBEs is the Kentucky Transportation's website: <http://transportation.ky.gov/Civil-Rights-and-Small-Business-Development/Pages/Certified-DBE-Directory.aspx>.
- The prime contractor certifies that a bidders list (see example sheet below) of qualified vendors, including DBEs, was developed for current and future solicitations and that the list will be maintained. *Submit a copy of the list as documentation.*
- (ii). Make information on forthcoming opportunities available to DBEs and arrange time frames for contracts and establish delivery schedules, where the requirements permit, in a way that encourages and facilitates participation by DBEs in the competitive process; including, whenever possible, posting solicitation for bids or proposals for a sufficient amount of time as to receive a competitive bid or proposal pool.
- The prime contractor certifies that every opportunity was provided to a number of DBEs to encourage their participation in the competitive process and that an adequate amount of time was provided for response.
- a. List each DBE construction firm or material supplier to which a solicitation was attempted. *Submit copies of letters, emails, faxes, telecommunication logs, certified mail receipts, returned envelopes, certified mail return receipts, etc. as documentation.*
- Company name and phone number: _____
 Area of work expertise: _____
 Date of any follow-ups and person spoke to: _____
- b. Advertisements, if applicable: List each publication in which an announcement or notification was placed. *Submit a tear sheet of each announcement from each publication as documentation.*
- Name of publication: _____
 Date(s) of advertisement: _____
 Specific subcontract areas announced: _____
- c. Other, if applicable: List each notification method in which an announcement or outreach was used; list serve, public meeting, etc. *Submit applicable information to document effort.*
- Method of notification: _____
 Date(s) of notification: _____
- (iii). Consider in the contracting process whether firms competing for large contracts could subcontract with DBEs; including dividing total requirements, when economically feasible, into smaller tasks or quantities to permit maximum participation by DBEs in the competitive process.
- The prime contractor certifies that the project was broken into its basic elements (i.e., dirt hauling, landscaping, painting, pipe installation, material supplies, etc.) and that a determination was made whether it's economically feasible to bid the elements separately and that the analysis of this effort was documented with a short memo to the project file.

- (iv). Establishing delivery schedules, where the requirement permits, which encourage participation by small and minority business, and women’s business enterprises.
 - The prime contractor certifies that they established delivery schedules which would allow DBEs to participate in the projects.

- (v). Use the services and assistance of the Small Business Administration (SBA) and the Minority Business Development Agency (MBDA) of the U.S. Department of Commerce. The easiest way to utilize the services of SBA and MBDA is to visit their websites: www.sba.gov and www.mbda.gov and use the electronic tools available there or you may send the nearest SBA and MBDA office a certified letter that generally describes the solicitation, the dates it will be open, the types of vendors you are seeking and applicable SIC or NAIC codes if known. You may also use the services and assistance of the Kentucky Procurement Assistance Program (KPAP). The easiest way to utilize the services of KPAP is to send an email: ced.kpap@ky.gov and provide information on forthcoming opportunities available to DBEs.
 - The prime contractor certifies that the assistance of the SBA, MBDA, and/or KPAP was utilized. *Submit pages printed off the SBA and MBDA websites which evidence efforts to register a solicitation on those sites or submit copies of the letter sent and certified mail receipt as documentation; submit copies of emails with KPAP as documentation.*

- (vi). If a subcontractor awards any subcontracts, require the subcontractor to take the steps in numbers (i) through (v) above.
 - The prime contractor certifies that subcontractors used for this project will be required to follow the steps of the “six good faith efforts” as listed above.

9. Signature and date:

To the best of my knowledge and belief, all “six good faith efforts” have been met and the information contained in this document is true and correct; the document has been duly authorized by the legal representative.

Signature

Print name and title

Date

Attachment Number 12

BONDS AND INSURANCE

The minimum requirements shall be as follows:

Bonding requirements for contracts of \$100,000 or less are contained in 40 CFR 31.36(h).

Bond requirements for contracts in excess of \$100,000 are:

- Bid guarantee equivalent to five percent of the bid price. The bid guarantee shall consist of a firm commitment such as a certified check or bid bond submitted with the bid;
- Performance bond equal to 100 percent of the contract price, and
- Payment bond equal to 100 percent of the contract price. Bonds must be obtained from companies holding Certificates of Authority as acceptable sureties, issued by the U.S. Treasury.

Insurance requirements are contained in the General Conditions of the contract. In addition to the other required insurance, the owner or the contractor, as appropriate, must acquire any flood insurance made available by the Federal Emergency Management Agency as required by 44 CFR Parts 59-79, if construction will take place in a flood hazard area identified by the Federal Emergency Management Agency. The owner's requirements on Flood Insurance are contained in the Special Conditions Section of the Contracts Documents.

Attachment Number 13

NOTICE OF INTENT

All construction projects with surface disturbance of more than 1 acre during the period of construction must have a KPDES Storm Water General Permit. The permit can be found at the following web address:

<https://dep.gateway.ky.gov/eForms/default.aspx?FormID=7>.

If you have any questions regarding the completion of this form call the Surface Water Permits Branch, at (502) 564-3410.

Attachment Number 14

Davis-Bacon Wage Rate Requirements

CWSRF: The recipient agrees to include in all agreements to provide assistance for the construction of treatment works carried out in whole or in part with such assistance made available by a State water pollution control revolving fund as authorized by title VI of the Federal Water Pollution Control Act (33 U.S.C. 1381 et seq.), or with such assistance made available under section 205(m) of that Act (33 U.S.C. 1285(m)), or both, a term and condition requiring compliance with the requirements of section 513 of that Act (33 U.S.C. 1372) in all procurement contracts and sub-grants, and require that loan recipients, procurement contractors and sub-grantees include such a term and condition in subcontracts and other lower tiered transactions. All contracts and subcontracts for the construction of treatment works carried out in whole or in part with assistance made available as stated herein shall insert in full in any contract in excess of \$2,000 the contract clauses as set forth below titled "Wage Rate Requirements Under The Consolidated and Further Continuing Appropriations Act, 2013 (P.L. 113-6)". This term and condition applies to all agreements to provide assistance under the authorities referenced herein, whether in the form of a loan, bond purchase, grant, or any other vehicle to provide financing for a project, where such agreements are executed on or after October 30, 2009.

DWSRF: The recipient agrees to include in all agreements to provide assistance for any construction project carried out in whole or in part with such assistance made available by a drinking water treatment revolving loan fund as authorized by section 1452 of the Safe Drinking Water Act (42 U.S.C. 300j-12), a term and condition requiring compliance with the requirements of section 1450(e) of the Safe Drinking Water Act (42 U.S.C.300j-9(e)) in all procurement contracts and sub-grants, and require that loan recipients, procurement contractors and sub-grantees include such a term and condition in subcontracts and other lower tiered transactions All contracts and subcontracts for any construction project carried out in whole or in part with assistance made available as stated herein shall insert in full in any contract in excess of \$2,000 the contract clauses as set forth below entitled "Wage Rate Requirements Under The Consolidated and Further Continuing Appropriations Act, 2013 (P.L. 113-6)". This term and condition applies to all agreements to provide assistance under the authorities referenced herein, whether in the form of a loan, bond purchase, grant, or any other vehicle to provide financing for a project, where such agreements are executed on or after October 30, 2009.

Wage Rate Requirements Under The Consolidated and Further Continuing Appropriations Act, 2013 (P.L. 113-6)**Preamble**

With respect to the Clean Water and Safe Drinking Water State Revolving Funds, EPA provides capitalization grants to each State which in turn provides subgrants or loans to eligible entities within the State. Typically, the subrecipients are municipal or other local governmental entities that manage the funds. For these types of recipients, the provisions set forth under Roman Numeral I, below, shall apply. Although EPA and the State remain responsible for ensuring subrecipients' compliance with the wage rate requirements set forth herein, those subrecipients shall have the primary responsibility to maintain payroll records as described in Section 3(ii)(A), below and for compliance as described in Section I-5.

Occasionally, the subrecipient may be a private for profit or not for profit entity. For these types of recipients, the provisions set forth in Roman Numeral II, below, shall apply. Although EPA and the State remain responsible for ensuring subrecipients' compliance with the wage rate requirements set forth herein, those subrecipients shall have the primary responsibility to maintain payroll records as described in Section II-3(ii)(A), below and for compliance as described in Section II-5.

I. Requirements Under The Consolidated and Further Continuing Appropriations Act, 2013 (P.L. 113-6) For Subrecipients That Are Governmental Entities:

The following terms and conditions specify how recipients will assist EPA in meeting its Davis-Bacon (DB) responsibilities when DB applies to EPA awards of financial assistance under the FY 2013 Continuing Resolution with respect to State recipients and subrecipients that are governmental entities. If a subrecipient has questions regarding when DB applies, obtaining the correct DB wage determinations, DB provisions, or compliance monitoring, it may contact the State recipient. The recipient or subrecipient may also obtain additional guidance from DOL's website at <http://www.dol.gov/whd/>

1. Applicability of the Davis- Bacon (DB) prevailing wage requirements.

Under the FY 2013 Continuing Resolution, DB prevailing wage requirements apply to the construction, alteration, and repair of treatment works carried out in whole or in part with assistance made available by a State water pollution control revolving fund and to any construction project carried out in whole or in part by assistance made available by a drinking water treatment revolving loan fund. If a subrecipient encounters a unique situation at a site that presents uncertainties regarding DB applicability, the subrecipient must discuss the situation with the recipient State before authorizing work on that site.

2. Obtaining Wage Determinations.

(a) Subrecipients shall obtain the wage determination for the locality in which a covered activity subject to DB will take place prior to issuing requests for bids, proposals, quotes or other methods for soliciting contracts (solicitation) for activities subject to DB. These wage determinations shall be incorporated into solicitations and any subsequent contracts. Prime contracts must contain a provision requiring that subcontractors follow the wage determination incorporated into the prime contract.

(i) While the solicitation remains open, the subrecipient shall monitor www.wdol.gov weekly to ensure that the wage determination contained in the solicitation remains current. The subrecipients shall amend the solicitation if DOL issues a modification more than 10 days prior to the closing date (i.e. bid opening) for the solicitation. If DOL modifies or supersedes the applicable wage determination less than 10 days prior to the closing date, the subrecipients may request a finding from the State recipient that there is not a reasonable time to notify interested contractors of the modification of the wage determination. The State recipient will provide a report of its findings to the subrecipient.

(ii) If the subrecipient does not award the contract within 90 days of the closure of the solicitation, any modifications or supersedes DOL makes to the wage determination contained in the solicitation shall be effective unless the State recipient, at the request

of the subrecipient, obtains an extension of the 90 day period from DOL pursuant to 29 CFR 1.6(c)(3)(iv). The subrecipient shall monitor www.wdol.gov on a weekly basis if it does not award the contract within 90 days of closure of the solicitation to ensure that wage determinations contained in the solicitation remain current.

(b) If the subrecipient carries out activity subject to DB by issuing a task order, work assignment or similar instrument to an existing contractor (ordering instrument) rather than by publishing a solicitation, the subrecipient shall insert the appropriate DOL wage determination from www.wdol.gov into the ordering instrument.

(c) Subrecipients shall review all subcontracts subject to DB entered into by prime contractors to verify that the prime contractor has required its subcontractors to include the applicable wage determinations.

(d) As provided in 29 CFR 1.6(f), DOL may issue a revised wage determination applicable to a subrecipient's contract after the award of a contract or the issuance of an ordering instrument if DOL determines that the subrecipient has failed to incorporate a wage determination or has used a wage determination that clearly does not apply to the contract or ordering instrument. If this occurs, the subrecipient shall either terminate the contract or ordering instrument and issue a revised solicitation or ordering instrument or incorporate DOL's wage determination retroactive to the beginning of the contract or ordering instrument by change order. The subrecipient's contractor must be compensated for any increases in wages resulting from the use of DOL's revised wage determination.

3. Contract and Subcontract provisions.

(a) The Recipient shall insure that the subrecipient(s) shall insert in full in any contract in excess of \$2,000 which is entered into for the actual construction, alteration and/or repair, including painting and decorating, of a treatment work under the CWSRF or a construction project under the DWSRF financed in whole or in part from Federal funds or in accordance with guarantees of a Federal agency or financed from funds obtained by pledge of any contract of a Federal agency to make a loan, grant or annual contribution (except where a different meaning is expressly indicated), and which is subject to the labor standards provisions of any of the acts listed in § 5.1 or the FY 2013 Continuing Resolution, the following clauses:

(1) Minimum wages.

(i) All laborers and mechanics employed or working upon the site of the work will be paid unconditionally and not less often than once a week, and without subsequent deduction or rebate on any account (except such payroll deductions as are permitted by regulations issued by the Secretary of Labor under the Copeland Act (29 CFR part 3)), the full amount of wages and bona fide fringe benefits (or cash equivalents thereof) due at time of payment computed at rates not less than those contained in the wage determination of the Secretary of Labor which is attached hereto and made a part hereof, regardless of any contractual relationship which may be alleged to exist between the contractor and such laborers and mechanics.

Contributions made or costs reasonably anticipated for bona fide fringe benefits under section 1(b)(2) of the Davis-Bacon Act on behalf of laborers or mechanics are considered wages paid to such laborers or mechanics, subject to the provisions of paragraph (a)(1)(iv) of this section; also, regular contributions made or costs incurred for more than a weekly period (but not less often

DOW- February, 2014

than quarterly) under plans, funds, or programs which cover the particular weekly period, are deemed to be constructively made or incurred during such weekly period. Such laborers and mechanics shall be paid the appropriate wage rate and fringe benefits on the wage determination for the classification of work actually performed, without regard to skill, except as provided in § 5.5(a)(4). Laborers or mechanics performing work in more than one classification may be compensated at the rate specified for each classification for the time actually worked therein: Provided, that the employer's payroll records accurately set forth the time spent in each classification in which work is performed. The wage determination (including any additional classification and wage rates conformed under paragraph (a)(1)(ii) of this section) and the Davis-Bacon poster (WH-1321) shall be posted at all times by the contractor and its subcontractors at the site of the work in a prominent and accessible place where it can be easily seen by the workers.

Subrecipients may obtain wage determinations from the U.S. Department of Labor's website, www.dol.gov.

(ii)(A) The subrecipient(s), on behalf of EPA, shall require that any class of laborers or mechanics, including helpers, which is not listed in the wage determination and which is to be employed under the contract shall be classified in conformance with the wage determination. The State award official shall approve a request for an additional classification and wage rate and fringe benefits therefore only when the following criteria have been met:

(1) The work to be performed by the classification requested is not performed by a classification in the wage determination; and

(2) The classification is utilized in the area by the construction industry; and

(3) The proposed wage rate, including any bona fide fringe benefits, bears a reasonable relationship to the wage rates contained in the wage determination.

(B) If the contractor and the laborers and mechanics to be employed in the classification (if known), or their representatives, and the subrecipient(s) agree on the classification and wage rate (including the amount designated for fringe benefits where appropriate), documentation of the action taken and the request, including the local wage determination shall be sent by the subrecipient (s) to the State award official. The State award official will transmit the request, to the Administrator of the Wage and Hour Division, Employment Standards Administration, U.S. Department of Labor, Washington, DC 20210 and to the EPA DB Regional Coordinator concurrently. The Administrator, or an authorized representative, will approve, modify, or disapprove every additional classification request within 30 days of receipt and so advise the State award official or will notify the State award official within the 30-day period that additional time is necessary.

(C) In the event the contractor, the laborers or mechanics to be employed in the classification or their representatives, and the subrecipient(s) do not agree on the proposed classification and wage rate (including the amount designated for fringe benefits, where appropriate), the award official shall refer the request and the local wage determination, including the views of all interested parties and the recommendation of the State award official, to the Administrator for determination. The request shall be sent to the EPA DB Regional Coordinator concurrently. The Administrator, or an authorized representative, will issue a determination within 30 days of

receipt of the request and so advise the contracting officer or will notify the contracting officer within the 30-day period that additional time is necessary.

(D) The wage rate (including fringe benefits where appropriate) determined pursuant to paragraphs (a)(1)(ii)(B) or (C) of this section, shall be paid to all workers performing work in the classification under this contract from the first day on which work is performed in the classification.

(iii) Whenever the minimum wage rate prescribed in the contract for a class of laborers or mechanics includes a fringe benefit which is not expressed as an hourly rate, the contractor shall either pay the benefit as stated in the wage determination or shall pay another bona fide fringe benefit or an hourly cash equivalent thereof.

(iv) If the contractor does not make payments to a trustee or other third person, the contractor may consider as part of the wages of any laborer or mechanic the amount of any costs reasonably anticipated in providing bona fide fringe benefits under a plan or program, Provided, That the Secretary of Labor has found, upon the written request of the contractor, that the applicable standards of the Davis-Bacon Act have been met. The Secretary of Labor may require the contractor to set aside in a separate account assets for the meeting of obligations under the plan or program.

(2) Withholding. The subrecipient(s), shall upon written request of the EPA Award Official or an authorized representative of the Department of Labor, withhold or cause to be withheld from the contractor under this contract or any other Federal contract with the same prime contractor, or any other federally-assisted contract subject to Davis-Bacon prevailing wage requirements, which is held by the same prime contractor, so much of the accrued payments or advances as may be considered necessary to pay laborers and mechanics, including apprentices, trainees, and helpers, employed by the contractor or any subcontractor the full amount of wages required by the contract. In the event of failure to pay any laborer or mechanic, including any apprentice, trainee, or helper, employed or working on the site of the work, all or part of the wages required by the contract, the (Agency) may, after written notice to the contractor, sponsor, applicant, or owner, take such action as may be necessary to cause the suspension of any further payment, advance, or guarantee of funds until such violations have ceased.

(3) Payrolls and basic records.

(i) Payrolls and basic records relating thereto shall be maintained by the contractor during the course of the work and preserved for a period of three years thereafter for all laborers and mechanics working at the site of the work. Such records shall contain the name, address, and social security number of each such worker, his or her correct classification, hourly rates of wages paid (including rates of contributions or costs anticipated for bona fide fringe benefits or cash equivalents thereof of the types described in section 1(b)(2)(B) of the Davis-Bacon Act), daily and weekly number of hours worked, deductions made and actual wages paid. Whenever the Secretary of Labor has found under 29 CFR 5.5(a)(1)(iv) that the wages of any laborer or mechanic include the amount of any costs reasonably anticipated in providing benefits under a plan or program described in section 1(b)(2)(B) of the Davis-Bacon Act, the contractor shall maintain records which show that the commitment to provide such benefits is enforceable, that the plan or program is financially responsible, and that the plan or program has been communicated in writing to the laborers or mechanics affected, and records which show the costs anticipated or the actual cost incurred in providing such benefits. Contractors employing

apprentices or trainees under approved programs shall maintain written evidence of the registration of apprenticeship programs and certification of trainee programs, the registration of the apprentices and trainees, and the ratios and wage rates prescribed in the applicable programs.

(ii)(A) The contractor shall submit weekly, for each week in which any contract work is performed, a copy of all payrolls to the subrecipient, that is, the entity that receives the sub-grant or loan from the State capitalization grant recipient. Such documentation shall be available on request of the State recipient or EPA. As to each payroll copy received, the subrecipient shall provide written confirmation in a form satisfactory to the State indicating whether or not the project is in compliance with the requirements of 29 CFR 5.5(a)(1) based on the most recent payroll copies for the specified week. The payrolls shall set out accurately and completely all of the information required to be maintained under 29 CFR 5.5(a)(3)(i), except that full social security numbers and home addresses shall not be included on the weekly payrolls. Instead the payrolls shall only need to include an individually identifying number for each employee (e.g., the last four digits of the employee's social security number). The required weekly payroll information may be submitted in any form desired. Optional Form WH-347 is available for this purpose from the Wage and Hour Division Web site at <http://www.dol.gov/whd/forms/wh347instr.htm> or its successor site. The prime contractor is responsible for the submission of copies of payrolls by all subcontractors. Contractors and subcontractors shall maintain the full social security number and current address of each covered worker, and shall provide them upon request to the subrecipient(s) for transmission to the State or EPA if requested by EPA, the State, the contractor, or the Wage and Hour Division of the Department of Labor for purposes of an investigation or audit of compliance with prevailing wage requirements. It is not a violation of this section for a prime contractor to require a subcontractor to provide addresses and social security numbers to the prime contractor for its own records, without weekly submission to the subrecipient(s).

(B) Each payroll submitted shall be accompanied by a "Statement of Compliance," signed by the contractor or subcontractor or his or her agent who pays or supervises the payment of the persons employed under the contract and shall certify the following:

(1) That the payroll for the payroll period contains the information required to be provided under §5.5 (a)(3)(ii) of Regulations, 29 CFR part 5, the appropriate information is being maintained under §5.5 (a)(3)(i) of Regulations, 29 CFR part 5, and that such information is correct and complete;

(2) That each laborer or mechanic (including each helper, apprentice, and trainee) employed on the contract during the payroll period has been paid the full weekly wages earned, without rebate, either directly or indirectly, and that no deductions have been made either directly or indirectly from the full wages earned, other than permissible deductions as set forth in Regulations, 29 CFR part 3;

(3) That each laborer or mechanic has been paid not less than the applicable wage rates and fringe benefits or cash equivalents for the classification of work performed, as specified in the applicable wage determination incorporated into the contract.

(C) The weekly submission of a properly executed certification set forth on the reverse side of Optional Form WH-347 shall satisfy the requirement for submission of the "Statement of Compliance" required by paragraph (a)(3)(ii)(B) of this section.

(D) The falsification of any of the above certifications may subject the contractor or subcontractor to civil or criminal prosecution under section 1001 of title 18 and section 231 of title 31 of the United States Code.

(iii) The contractor or subcontractor shall make the records required under paragraph (a)(3)(i) of this section available for inspection, copying, or transcription by authorized representatives of the State, EPA or the Department of Labor, and shall permit such representatives to interview employees during working hours on the job. If the contractor or subcontractor fails to submit the required records or to make them available, the Federal agency or State may, after written notice to the contractor, sponsor, applicant, or owner, take such action as may be necessary to cause the suspension of any further payment, advance, or guarantee of funds. Furthermore, failure to submit the required records upon request or to make such records available may be grounds for debarment action pursuant to 29 CFR 5.12.

(4) Apprentices and trainees.

(i) Apprentices. Apprentices will be permitted to work at less than the predetermined rate for the work they performed when they are employed pursuant to and individually registered in a bona fide apprenticeship program registered with the U.S. Department of Labor, Employment and Training Administration, Office of Apprenticeship Training, Employer and Labor Services, or with a State Apprenticeship Agency recognized by the Office, or if a person is employed in his or her first 90 days of probationary employment as an apprentice in such an apprenticeship program, who is not individually registered in the program, but who has been certified by the Office of Apprenticeship Training, Employer and Labor Services or a State Apprenticeship Agency (where appropriate) to be eligible for probationary employment as an apprentice. The allowable ratio of apprentices to journeymen on the job site in any craft classification shall not be greater than the ratio permitted to the contractor as to the entire work force under the registered program. Any worker listed on a payroll at an apprentice wage rate, who is not registered or otherwise employed as stated above, shall be paid not less than the applicable wage rate on the wage determination for the classification of work actually performed. In addition, any apprentice performing work on the job site in excess of the ratio permitted under the registered program shall be paid not less than the applicable wage rate on the wage determination for the work actually performed. Where a contractor is performing construction on a project in a locality other than that in which its program is registered, the ratios and wage rates (expressed in percentages of the journeyman's hourly rate) specified in the contractor's or subcontractor's registered program shall be observed. Every apprentice must be paid at not less than the rate specified in the registered program for the apprentice's level of progress, expressed as a percentage of the journeymen hourly rate specified in the applicable wage determination. Apprentices shall be paid fringe benefits in accordance with the provisions of the apprenticeship program. If the apprenticeship program does not specify fringe benefits, apprentices must be paid the full amount of fringe benefits listed on the wage determination for the applicable classification. If the Administrator determines that a different practice prevails for the applicable apprentice classification, fringes shall be paid in accordance with that determination. In the event the Office of Apprenticeship Training, Employer and Labor Services, or a State Apprenticeship Agency recognized by the Office, withdraws approval of an apprenticeship program, the contractor will no longer be permitted to utilize apprentices at less than the applicable predetermined rate for the work performed until an acceptable program is approved.

(ii) Trainees. Except as provided in 29 CFR 5.16, trainees will not be permitted to work at less than the predetermined rate for the work performed unless they are employed pursuant to and

DOW- February, 2014

individually registered in a program which has received prior approval, evidenced by formal certification by the U.S. Department of Labor, Employment and Training Administration. The ratio of trainees to journeymen on the job site shall not be greater than permitted under the plan approved by the Employment and Training Administration. Every trainee must be paid at not less than the rate specified in the approved program for the trainee's level of progress, expressed as a percentage of the journeyman hourly rate specified in the applicable wage determination. Trainees shall be paid fringe benefits in accordance with the provisions of the trainee program. If the trainee program does not mention fringe benefits, trainees shall be paid the full amount of fringe benefits listed on the wage determination unless the Administrator of the Wage and Hour Division determines that there is an apprenticeship program associated with the corresponding journeyman wage rate on the wage determination which provides for less than full fringe benefits for apprentices. Any employee listed on the payroll at a trainee rate who is not registered and participating in a training plan approved by the Employment and Training Administration shall be paid not less than the applicable wage rate on the wage determination for the classification of work actually performed. In addition, any trainee performing work on the job site in excess of the ratio permitted under the registered program shall be paid not less than the applicable wage rate on the wage determination for the work actually performed. In the event the Employment and Training Administration withdraws approval of a training program, the contractor will no longer be permitted to utilize trainees at less than the applicable predetermined rate for the work performed until an acceptable program is approved.

(iii) Equal employment opportunity. The utilization of apprentices, trainees and journeymen under this part shall be in conformity with the equal employment opportunity requirements of Executive Order 11246, as amended, and 29 CFR part 30.

(5) Compliance with Copeland Act requirements. The contractor shall comply with the requirements of 29 CFR part 3, which are incorporated by reference in this contract.

(6) Subcontracts. The contractor or subcontractor shall insert in any subcontracts the clauses contained in 29 CFR 5.5(a)(1) through (10) and such other clauses as the EPA determines may be appropriate, and also a clause requiring the subcontractors to include these clauses in any lower tier subcontracts. The prime contractor shall be responsible for the compliance by any subcontractor or lower tier subcontractor with all the contract clauses in 29 CFR 5.5.

(7) Contract termination; debarment. A breach of the contract clauses in 29 CFR 5.5 may be grounds for termination of the contract, and for debarment as a contractor and a subcontractor as provided in 29 CFR 5.12.

(8) Compliance with Davis-Bacon and Related Act requirements. All rulings and interpretations of the Davis-Bacon and Related Acts contained in 29 CFR parts 1, 3, and 5 are herein incorporated by reference in this contract.

(9) Disputes concerning labor standards. Disputes arising out of the labor standards provisions of this contract shall not be subject to the general disputes clause of this contract. Such disputes shall be resolved in accordance with the procedures of the Department of Labor set forth in 29 CFR parts 5, 6, and 7. Disputes within the meaning of this clause include disputes between the contractor (or any of its subcontractors) and Subrecipient(s), State, EPA, the U.S. Department of Labor, or the employees or their representatives.

(10) Certification of eligibility.

DOW- February, 2014

(i) By entering into this contract, the contractor certifies that neither it (nor he or she) nor any person or firm who has an interest in the contractor's firm is a person or firm ineligible to be awarded Government contracts by virtue of section 3(a) of the Davis-Bacon Act or 29 CFR 5.12(a)(1).

(ii) No part of this contract shall be subcontracted to any person or firm ineligible for award of a Government contract by virtue of section 3(a) of the Davis-Bacon Act or 29 CFR 5.12(a)(1).

(iii) The penalty for making false statements is prescribed in the U.S. Criminal Code, 18 U.S.C. 1001.

4. Contract Provision for Contracts in Excess of \$100,000.

(a) Contract Work Hours and Safety Standards Act. The subrecipient shall insert the following clauses set forth in paragraphs (a)(1), (2), (3), and (4) of this section in full in any contract in an amount in excess of \$100,000 and subject to the overtime provisions of the Contract Work Hours and Safety Standards Act. These clauses shall be inserted in addition to the clauses required by Item 3, above or 29 CFR 4.6. As used in this paragraph, the terms laborers and mechanics include watchmen and guards.

(1) Overtime requirements. No contractor or subcontractor contracting for any part of the contract work which may require or involve the employment of laborers or mechanics shall require or permit any such laborer or mechanic in any workweek in which he or she is employed on such work to work in excess of forty hours in such workweek unless such laborer or mechanic receives compensation at a rate not less than one and one-half times the basic rate of pay for all hours worked in excess of forty hours in such workweek.

(2) Violation; liability for unpaid wages; liquidated damages. In the event of any violation of the clause set forth in paragraph (a)(1) of this section the contractor and any subcontractor responsible therefore shall be liable for the unpaid wages. In addition, such contractor and subcontractor shall be liable to the United States (in the case of work done under contract for the District of Columbia or a territory, to such District or to such territory), for liquidated damages. Such liquidated damages shall be computed with respect to each individual laborer or mechanic, including watchmen and guards, employed in violation of the clause set forth in paragraph (a)(1) of this section, in the sum of \$10 for each calendar day on which such individual was required or permitted to work in excess of the standard workweek of forty hours without payment of the overtime wages required by the clause set forth in paragraph (a)(1) of this section.

(3) Withholding for unpaid wages and liquidated damages. The subrecipient, upon written request of the EPA Award Official or an authorized representative of the Department of Labor, shall withhold or cause to be withheld, from any moneys payable on account of work performed by the contractor or subcontractor under any such contract or any other Federal contract with the same prime contractor, or any other federally-assisted contract subject to the Contract Work Hours and Safety Standards Act, which is held by the same prime contractor, such sums as may be determined to be necessary to satisfy any liabilities of such contractor or subcontractor for unpaid wages and liquidated damages as provided in the clause set forth in paragraph (b)(2) of this section.

(4) Subcontracts. The contractor or subcontractor shall insert in any subcontracts the clauses set forth in paragraph (a)(1) through (4) of this section and also a clause requiring the subcontractors to include these clauses in any lower tier subcontracts. The prime contractor shall be responsible for compliance by any subcontractor or lower tier subcontractor with the clauses set forth in paragraphs (a)(1) through (4) of this section.

(b) In addition to the clauses contained in Item 3, above, in any contract subject only to the Contract Work Hours and Safety Standards Act and not to any of the other statutes cited in 29 CFR 5.1, the Subrecipient shall insert a clause requiring that the contractor or subcontractor shall maintain payrolls and basic payroll records during the course of the work and shall preserve them for a period of three years from the completion of the contract for all laborers and mechanics, including guards and watchmen, working on the contract. Such records shall contain the name and address of each such employee, social security number, correct classifications, hourly rates of wages paid, daily and weekly number of hours worked, deductions made, and actual wages paid. Further, the Subrecipient shall insert in any such contract a clause providing that the records to be maintained under this paragraph shall be made available by the contractor or subcontractor for inspection, copying, or transcription by authorized representatives of the (write the name of agency) and the Department of Labor, and the contractor or subcontractor will permit such representatives to interview employees during working hours on the job.

5. Compliance Verification.

(a) The subrecipient shall periodically interview a sufficient number of employees entitled to DB prevailing wages (covered employees) to verify that contractors or subcontractors are paying the appropriate wage rates. As provided in 29 CFR 5.6(a)(6), all interviews must be conducted in confidence. The subrecipient must use Standard Form 1445 (SF 1445) or equivalent documentation to memorialize the interviews. Copies of the SF 1445 are available from EPA on request.

(b) The subrecipient shall establish and follow an interview schedule based on its assessment of the risks of noncompliance with DB posed by contractors or subcontractors and the duration of the contract or subcontract. Subrecipients must conduct more frequent interviews if the initial interviews or other information indicates that there is a risk that the contractor or subcontractor is not complying with DB. Subrecipients shall immediately conduct necessary interviews in response to an alleged violation of the prevailing wage requirements. All interviews shall be conducted in confidence.

(c) The subrecipient shall periodically conduct spot checks of a representative sample of weekly payroll data to verify that contractors or subcontractors are paying the appropriate wage rates. The subrecipient shall establish and follow a spot check schedule based on its assessment of the risks of noncompliance with DB posed by contractors or subcontractors and the duration of the contract or subcontract. At a minimum, if practicable, the subrecipient should spot check payroll data within two weeks of each contractor or subcontractor's submission of its initial payroll data and two weeks prior to the completion date the contract or subcontract. Subrecipients must conduct more frequent spot checks if the initial spot check or other information indicates that there is a risk that the contractor or subcontractor is not complying with DB. In addition, during the examinations the subrecipient shall verify evidence of fringe benefit plans and payments thereunder by contractors and subcontractors who claim credit for fringe benefit contributions.

(d) The subrecipient shall periodically review contractors and subcontractor's use of apprentices and trainees to verify registration and certification with respect to apprenticeship and training programs approved by either the U.S Department of Labor or a state, as appropriate, and that contractors and subcontractors are not using disproportionate numbers of, laborers, trainees and apprentices. These reviews shall be conducted in accordance with the schedules for spot checks and interviews described in Item 5(b) and (c) above.

(e) Subrecipients must immediately report potential violations of the DB prevailing wage requirements to the EPA DB contact listed above and to the appropriate DOL Wage and Hour District Office listed at <http://www.dol.gov/contacts/whd/america2.htm>.

II. Requirements Under The Consolidated and further Continuing Appropriations Act, 2013 (P.L. 113-6) For Subrecipients That Are Not Governmental Agencies

The following terms and conditions specify how recipients will assist EPA in meeting its DB responsibilities when DB applies to EPA awards of financial assistance under the FY2013 Continuing Resolution with respect to subrecipients that are not governmental entities. If a subrecipient has questions regarding when DB applies, obtaining the correct DB wage determinations, DB provisions, or compliance monitoring, it may contact the State recipient for guidance. The recipient or subrecipient may also obtain additional guidance from DOL's web site at <http://www.dol.gov/whd/>.

Under these terms and conditions, the subrecipient must submit its proposed DB wage determinations to the State recipient for approval prior to including the wage determination in any solicitation, contract task orders, work assignments, or similar instruments to existing contractors.

1. Applicability of the Davis- Bacon (DB) prevailing wage requirements.

Under the FY 2013 Continuing Resolution, Davis-Bacon prevailing wage requirements apply to the construction, alteration, and repair of treatment works carried out in whole or in part with assistance made available by a State water pollution control revolving fund and to any construction project carried out in whole or in part by assistance made available by a drinking water treatment revolving loan fund. If a subrecipient encounters a unique situation at a site that presents uncertainties regarding DB applicability, the subrecipient must discuss the situation with the recipient State before authorizing work on that site.

2. Obtaining Wage Determinations.

(a) Subrecipients must obtain proposed wage determinations for specific localities at www.wdol.gov. After the Subrecipient obtains its proposed wage determination, it must submit the wage determination to (insert contact information for State recipient DB point of contact for wage determination) for approval prior to inserting the wage determination into a solicitation, contract or issuing task orders, work assignments or similar instruments to existing contractors (ordering instruments unless subsequently directed otherwise by the State recipient Award Official).

(b) Subrecipients shall obtain the wage determination for the locality in which a covered activity subject to DB will take place prior to issuing requests for bids, proposals, quotes or other methods for soliciting contracts (solicitation) for activities subject to DB. These wage determinations shall be incorporated into solicitations and any subsequent contracts. Prime contracts must contain a provision requiring that subcontractors follow the wage determination incorporated into the prime contract.

(i) While the solicitation remains open, the subrecipient shall monitor www.wdol.gov on a weekly basis to ensure that the wage determination contained in the solicitation remains current. The subrecipients shall amend the solicitation if DOL issues a modification more than 10 days prior to the closing date (i.e. bid opening) for the solicitation. If DOL modifies or supersedes the applicable wage determination less than 10 days prior to the closing date, the subrecipients may request a finding from the State recipient that there is not a reasonable time to notify interested contractors of the modification of the wage determination. The State recipient will provide a report of its findings to the subrecipient.

(ii) If the subrecipient does not award the contract within 90 days of the closure of the solicitation, any modifications or supersedes DOL makes to the wage determination contained in the solicitation shall be effective unless the State recipient, at the request of the subrecipient, obtains an extension of the 90 day period from DOL pursuant to 29 CFR 1.6(c)(3)(iv). The subrecipient shall monitor www.wdol.gov on a weekly basis if it does not award the contract within 90 days of closure of the solicitation to ensure that wage determinations contained in the solicitation remain current.

(c) If the subrecipient carries out activity subject to DB by issuing a task order, work assignment or similar instrument to an existing contractor (ordering instrument) rather than by publishing a solicitation, the subrecipient shall insert the appropriate DOL wage determination from www.wdol.gov into the ordering instrument.

(c) Subrecipients shall review all subcontracts subject to DB entered into by prime contractors to verify that the prime contractor has required its subcontractors to include the applicable wage determinations.

(d) As provided in 29 CFR 1.6(f), DOL may issue a revised wage determination applicable to a subrecipient's contract after the award of a contract or the issuance of an ordering instrument if DOL determines that the subrecipient has failed to incorporate a wage determination or has used a wage determination that clearly does not apply to the contract or ordering instrument. If this occurs, the subrecipient shall either terminate the contract or ordering instrument and issue a revised solicitation or ordering instrument or incorporate DOL's wage determination retroactive to the beginning of the contract or ordering instrument by change order. The subrecipient's contractor must be compensated for any increases in wages resulting from the use of DOL's revised wage determination.

3. Contract and Subcontract provisions.

(a) The Recipient shall insure that the subrecipient(s) shall insert in full in any contract in excess of \$2,000 which is entered into for the actual construction, alteration and/or repair, including painting and decorating, of a treatment work under the CWSRF or a construction project under the DWSRF financed in whole or in part from Federal funds or in accordance with guarantees of a Federal agency or financed from funds obtained by pledge of any contract of a Federal agency

DOW- February, 2014

to make a loan, grant or annual contribution (except where a different meaning is expressly indicated), and which is subject to the labor standards provisions of any of the acts listed in § 5.1 or the FY 2013 Continuing Resolution, the following clauses:

(1) Minimum wages.

(i) All laborers and mechanics employed or working upon the site of the work, will be paid unconditionally and not less often than once a week, and without subsequent deduction or rebate on any account (except such payroll deductions as are permitted by regulations issued by the Secretary of Labor under the Copeland Act (29 CFR part 3)), the full amount of wages and bona fide fringe benefits (or cash equivalents thereof) due at time of payment computed at rates not less than those contained in the wage determination of the Secretary of Labor which is attached hereto and made a part hereof, regardless of any contractual relationship which may be alleged to exist between the contractor and such laborers and mechanics.

Contributions made or costs reasonably anticipated for bona fide fringe benefits under section 1(b)(2) of the Davis-Bacon Act on behalf of laborers or mechanics are considered wages paid to such laborers or mechanics, subject to the provisions of paragraph (a)(1)(iv) of this section; also, regular contributions made or costs incurred for more than a weekly period (but not less often than quarterly) under plans, funds, or programs which cover the particular weekly period, are deemed to be constructively made or incurred during such weekly period. Such laborers and mechanics shall be paid the appropriate wage rate and fringe benefits on the wage determination for the classification of work actually performed, without regard to skill, except as provided in § 5.5(a)(4). Laborers or mechanics performing work in more than one classification may be compensated at the rate specified for each classification for the time actually worked therein: Provided, that the employer's payroll records accurately set forth the time spent in each classification in which work is performed. The wage determination (including any additional classification and wage rates conformed under paragraph (a)(1)(ii) of this section) and the Davis-Bacon poster (WH-1321) shall be posted at all times by the contractor and its subcontractors at the site of the work in a prominent and accessible place where it can be easily seen by the workers.

Subrecipients may obtain wage determinations from the U.S. Department of Labor's web site, www.dol.gov.

(ii)(A) The subrecipient(s), on behalf of EPA, shall require that any class of laborers or mechanics, including helpers, which is not listed in the wage determination and which is to be employed under the contract shall be classified in conformance with the wage determination. The State award official shall approve a request for an additional classification and wage rate and fringe benefits therefore only when the following criteria have been met:

- (1) The work to be performed by the classification requested is not performed by a classification in the wage determination; and
- (2) The classification is utilized in the area by the construction industry; and
- (3) The proposed wage rate, including any bona fide fringe benefits, bears a reasonable relationship to the wage rates contained in the wage determination.

(B) If the contractor and the laborers and mechanics to be employed in the classification (if known), or their representatives, and the subrecipient(s) agree on the classification and wage rate (including the amount designated for fringe benefits where appropriate), documentation of the action taken and the request, including the local wage determination shall be sent by the subrecipient(s) to the State award official. The State award official will transmit the report, to the Administrator of the Wage and Hour Division, Employment Standards Administration, U.S. Department of Labor, Washington, DC 20210 and to the EPA DB Regional Coordinator concurrently. The Administrator, or an authorized representative, will approve, modify, or disapprove every additional classification request within 30 days of receipt and so advise the State award official or will notify the State award official within the 30-day period that additional time is necessary.

(C) In the event the contractor, the laborers or mechanics to be employed in the classification or their representatives, and the and the subrecipient(s) do not agree on the proposed classification and wage rate (including the amount designated for fringe benefits, where appropriate), the award official shall refer the request, and the local wage determination, including the views of all interested parties and the recommendation of the State award official, to the Administrator for determination. The request shall be sent to the EPA Regional Coordinator concurrently. The Administrator, or an authorized representative, will issue a determination within 30 days of receipt of the request and so advise the contracting officer or will notify the contracting officer within the 30-day period that additional time is necessary.

(D) The wage rate (including fringe benefits where appropriate) determined pursuant to paragraphs (a)(1)(ii)(B) or (C) of this section, shall be paid to all workers performing work in the classification under this contract from the first day on which work is performed in the classification.

(iii) Whenever the minimum wage rate prescribed in the contract for a class of laborers or mechanics includes a fringe benefit which is not expressed as an hourly rate, the contractor shall either pay the benefit as stated in the wage determination or shall pay another bona fide fringe benefit or an hourly cash equivalent thereof.

(iv) If the contractor does not make payments to a trustee or other third person, the contractor may consider as part of the wages of any laborer or mechanic the amount of any costs reasonably anticipated in providing bona fide fringe benefits under a plan or program, Provided, That the Secretary of Labor has found, upon the written request of the contractor, that the applicable standards of the Davis-Bacon Act have been met. The Secretary of Labor may require the contractor to set aside in a separate account assets for the meeting of obligations under the plan or program.

(2) Withholding. The subrecipient(s) shall upon written request of the EPA Award Official or an authorized representative of the Department of Labor, withhold or cause to be withheld from the contractor under this contract or any other Federal contract with the same prime contractor, or any other federally-assisted contract subject to Davis-Bacon prevailing wage requirements, which is held by the same prime contractor, so much of the accrued payments or advances as may be considered necessary to pay laborers and mechanics, including apprentices, trainees, and helpers, employed by the contractor or any subcontractor the full amount of wages required by the contract. In the event of failure to pay any laborer or mechanic, including any apprentice, trainee, or helper, employed or working on the site of the work, all or part of the wages required by the contract, the (Agency) may, after written notice to the contractor, sponsor, applicant, or
DOW- February, 2014

owner, take such action as may be necessary to cause the suspension of any further payment, advance, or guarantee of funds until such violations have ceased.

(3) Payrolls and basic records.

(i) Payrolls and basic records relating thereto shall be maintained by the contractor during the course of the work and preserved for a period of three years thereafter for all laborers and mechanics working at the site of the work. Such records shall contain the name, address, and social security number of each such worker, his or her correct classification, hourly rates of wages paid (including rates of contributions or costs anticipated for bona fide fringe benefits or cash equivalents thereof of the types described in section 1(b)(2)(B) of the Davis-Bacon Act), daily and weekly number of hours worked, deductions made and actual wages paid. Whenever the Secretary of Labor has found under 29 CFR 5.5(a)(1)(iv) that the wages of any laborer or mechanic include the amount of any costs reasonably anticipated in providing benefits under a plan or program described in section 1(b)(2)(B) of the Davis-Bacon Act, the contractor shall maintain records which show that the commitment to provide such benefits is enforceable, that the plan or program is financially responsible, and that the plan or program has been communicated in writing to the laborers or mechanics affected, and records which show the costs anticipated or the actual cost incurred in providing such benefits. Contractors employing apprentices or trainees under approved programs shall maintain written evidence of the registration of apprenticeship programs and certification of trainee programs, the registration of the apprentices and trainees, and the ratios and wage rates prescribed in the applicable programs.

(ii)(A) The contractor shall submit weekly, for each week in which any contract work is performed, a copy of all payrolls to the subrecipient, that is, the entity that receives the sub-grant or loan from the State capitalization grant recipient. Such documentation shall be available on request of the State recipient or EPA. As to each payroll copy received, the subrecipient shall provide written confirmation in a form satisfactory to the State indicating whether or not the project is in compliance with the requirements of 29 CFR 5.5(a)(1) based on the most recent payroll copies for the specified week. The payrolls shall set out accurately and completely all of the information required to be maintained under 29 CFR 5.5(a)(3)(i), except that full social security numbers and home addresses shall not be included on the weekly payrolls. Instead the payrolls shall only need to include an individually identifying number for each employee (e.g., the last four digits of the employee's social security number). The required weekly payroll information may be submitted in any form desired. Optional Form WH-347 is available for this purpose from the Wage and Hour Division Web site at <http://www.dol.gov/whd/forms/wh347instr.htm> or its successor site. The prime contractor is responsible for the submission of copies of payrolls by all subcontractors. Contractors and subcontractors shall maintain the full social security number and current address of each covered worker, and shall provide them upon request to the subrecipient(s) for transmission to the State or EPA if requested by EPA, the State, the contractor, or the Wage and Hour Division of the Department of Labor for purposes of an investigation or audit of compliance with prevailing wage requirements. It is not a violation of this section for a prime contractor to require a subcontractor to provide addresses and social security numbers to the prime contractor for its own records, without weekly submission to the subrecipient(s).

(B) Each payroll submitted shall be accompanied by a "Statement of Compliance," signed by the contractor or subcontractor or his or her agent who pays or supervises the payment of the persons employed under the contract and shall certify the following:

(1) That the payroll for the payroll period contains the information required to be provided under § 5.5 (a)(3)(ii) of Regulations, 29 CFR part 5, the appropriate information is being maintained under § 5.5 (a)(3)(i) of Regulations, 29 CFR part 5, and that such information is correct and complete;

(2) That each laborer or mechanic (including each helper, apprentice, and trainee) employed on the contract during the payroll period has been paid the full weekly wages earned, without rebate, either directly or indirectly, and that no deductions have been made either directly or indirectly from the full wages earned, other than permissible deductions as set forth in Regulations, 29 CFR part 3;

(3) That each laborer or mechanic has been paid not less than the applicable wage rates and fringe benefits or cash equivalents for the classification of work performed, as specified in the applicable wage determination incorporated into the contract.

(C) The weekly submission of a properly executed certification set forth on the reverse side of Optional Form WH-347 shall satisfy the requirement for submission of the "Statement of Compliance" required by paragraph (a)(3)(ii)(B) of this section.

(D) The falsification of any of the above certifications may subject the contractor or subcontractor to civil or criminal prosecution under section 1001 of title 18 and section 231 of title 31 of the United States Code.

(iii) The contractor or subcontractor shall make the records required under paragraph (a)(3)(i) of this section available for inspection, copying, or transcription by authorized representatives of the State, EPA or the Department of Labor, and shall permit such representatives to interview employees during working hours on the job. If the contractor or subcontractor fails to submit the required records or to make them available, the Federal agency or State may, after written notice to the contractor, sponsor, applicant, or owner, take such action as may be necessary to cause the suspension of any further payment, advance, or guarantee of funds. Furthermore, failure to submit the required records upon request or to make such records available may be grounds for debarment action pursuant to 29 CFR 5.12.

(4) Apprentices and trainees.

(i) Apprentices. Apprentices will be permitted to work at less than the predetermined rate for the work they performed when they are employed pursuant to and individually registered in a bona fide apprenticeship program registered with the U.S. Department of Labor, Employment and Training Administration, Office of Apprenticeship Training, Employer and Labor Services, or with a State Apprenticeship Agency recognized by the Office, or if a person is employed in his or her first 90 days of probationary employment as an apprentice in such an apprenticeship program, who is not individually registered in the program, but who has been certified by the Office of Apprenticeship Training, Employer and Labor Services or a State Apprenticeship Agency (where appropriate) to be eligible for probationary employment as an apprentice. The allowable ratio of apprentices to journeymen on the job site in any craft classification shall not be greater than the ratio permitted to the contractor as to the entire work force under the registered program. Any worker listed on a payroll at an apprentice wage rate, who is not registered or otherwise employed as stated above, shall be paid not less than the applicable wage rate on the wage determination for the classification of work actually performed. In addition, any apprentice performing work on the job site in excess of the ratio permitted under the registered program

shall be paid not less than the applicable wage rate on the wage determination for the work actually performed. Where a contractor is performing construction on a project in a locality other than that in which its program is registered, the ratios and wage rates (expressed in percentages of the journeyman's hourly rate) specified in the contractor's or subcontractor's registered program shall be observed. Every apprentice must be paid at not less than the rate specified in the registered program for the apprentice's level of progress, expressed as a percentage of the journeymen hourly rate specified in the applicable wage determination. Apprentices shall be paid fringe benefits in accordance with the provisions of the apprenticeship program. If the apprenticeship program does not specify fringe benefits, apprentices must be paid the full amount of fringe benefits listed on the wage determination for the applicable classification. If the Administrator determines that a different practice prevails for the applicable apprentice classification, fringes shall be paid in accordance with that determination. In the event the Office of Apprenticeship Training, Employer and Labor Services, or a State Apprenticeship Agency recognized by the Office, withdraws approval of an apprenticeship program, the contractor will no longer be permitted to utilize apprentices at less than the applicable predetermined rate for the work performed until an acceptable program is approved.

(ii) Trainees. Except as provided in 29 CFR 5.16, trainees will not be permitted to work at less than the predetermined rate for the work performed unless they are employed pursuant to and individually registered in a program which has received prior approval, evidenced by formal certification by the U.S. Department of Labor, Employment and Training Administration. The ratio of trainees to journeymen on the job site shall not be greater than permitted under the plan approved by the Employment and Training Administration. Every trainee must be paid at not less than the rate specified in the approved program for the trainee's level of progress, expressed as a percentage of the journeyman hourly rate specified in the applicable wage determination. Trainees shall be paid fringe benefits in accordance with the provisions of the trainee program. If the trainee program does not mention fringe benefits, trainees shall be paid the full amount of fringe benefits listed on the wage determination unless the Administrator of the Wage and Hour Division determines that there is an apprenticeship program associated with the corresponding journeyman wage rate on the wage determination which provides for less than full fringe benefits for apprentices. Any employee listed on the payroll at a trainee rate who is not registered and participating in a training plan approved by the Employment and Training Administration shall be paid not less than the applicable wage rate on the wage determination for the classification of work actually performed. In addition, any trainee performing work on the job site in excess of the ratio permitted under the registered program shall be paid not less than the applicable wage rate on the wage determination for the work actually performed. In the event the Employment and Training Administration withdraws approval of a training program, the contractor will no longer be permitted to utilize trainees at less than the applicable predetermined rate for the work performed until an acceptable program is approved.

(iii) Equal employment opportunity. The utilization of apprentices, trainees and journeymen under this part shall be in conformity with the equal employment opportunity requirements of Executive Order 11246, as amended, and 29 CFR part 30.

(5) Compliance with Copeland Act requirements. The contractor shall comply with the requirements of 29 CFR part 3, which are incorporated by reference in this contract.

(6) Subcontracts. The contractor or subcontractor shall insert in any subcontracts the clauses contained in 29 CFR 5.5(a)(1) through (10) and such other clauses as the EPA determines may be appropriate, and also a clause requiring the subcontractors to include these clauses in any

DOW- February, 2014

lower tier subcontracts. The prime contractor shall be responsible for the compliance by any subcontractor or lower tier subcontractor with all the contract clauses in 29 CFR 5.5.

(7) Contract termination: debarment. A breach of the contract clauses in 29 CFR 5.5 may be grounds for termination of the contract, and for debarment as a contractor and a subcontractor as provided in 29 CFR 5.12.

(8) Compliance with Davis-Bacon and Related Act requirements. All rulings and interpretations of the Davis-Bacon and Related Acts contained in 29 CFR parts 1, 3, and 5 are herein incorporated by reference in this contract.

(9) Disputes concerning labor standards. Disputes arising out of the labor standards provisions of this contract shall not be subject to the general disputes clause of this contract. Such disputes shall be resolved in accordance with the procedures of the Department of Labor set forth in 29 CFR parts 5, 6, and 7. Disputes within the meaning of this clause include disputes between the contractor (or any of its subcontractors) and Subrecipient(s), State, EPA, the U.S. Department of Labor, or the employees or their representatives.

(10) Certification of eligibility.

(i) By entering into this contract, the contractor certifies that neither it (nor he or she) nor any person or firm who has an interest in the contractor's firm is a person or firm ineligible to be awarded Government contracts by virtue of section 3(a) of the Davis-Bacon Act or 29 CFR 5.12(a)(1).

(ii) No part of this contract shall be subcontracted to any person or firm ineligible for award of a Government contract by virtue of section 3(a) of the Davis-Bacon Act or 29 CFR 5.12(a)(1).

(iii) The penalty for making false statements is prescribed in the U.S. Criminal Code, 18 U.S.C. 1001.

4. Contract Provision for Contracts in Excess of \$100,000.

(a) Contract Work Hours and Safety Standards Act. The subrecipient shall insert the following clauses set forth in paragraphs (a)(1), (2), (3), and (4) of this section in full in any contract in an amount in excess of \$100,000 and subject to the overtime provisions of the Contract Work Hours and Safety Standards Act. These clauses shall be inserted in addition to the clauses required by Item 3, above or 29 CFR 4.6. As used in this paragraph, the terms laborers and mechanics include watchmen and guards.

(1) Overtime requirements. No contractor or subcontractor contracting for any part of the contract work which may require or involve the employment of laborers or mechanics shall require or permit any such laborer or mechanic in any workweek in which he or she is employed on such work to work in excess of forty hours in such workweek unless such laborer or mechanic receives compensation at a rate not less than one and one-half times the basic rate of pay for all hours worked in excess of forty hours in such workweek.

(2) Violation; liability for unpaid wages; liquidated damages. In the event of any violation of the clause set forth in paragraph (b)(1) of this section the contractor and any subcontractor responsible therefore shall be liable for the unpaid wages. In addition, such contractor and

subcontractor shall be liable to the United States (in the case of work done under contract for the District of Columbia or a territory, to such District or to such territory), for liquidated damages. Such liquidated damages shall be computed with respect to each individual laborer or mechanic, including watchmen and guards, employed in violation of the clause set forth in paragraph (b)(1) of this section, in the sum of \$10 for each calendar day on which such individual was required or permitted to work in excess of the standard workweek of forty hours without payment of the overtime wages required by the clause set forth in paragraph (b)(1) of this section.

(3) Withholding for unpaid wages and liquidated damages. The subrecipient shall upon the request of the EPA Award Official or an authorized representative of the Department of Labor, withhold or cause to be withheld, from any moneys payable on account of work performed by the contractor or subcontractor under any such contract or any other Federal contract with the same prime contractor, or any other federally-assisted contract subject to the Contract Work Hours and Safety Standards Act, which is held by the same prime contractor, such sums as may be determined to be necessary to satisfy any liabilities of such contractor or subcontractor for unpaid wages and liquidated damages as provided in the clause set forth in paragraph (a)(2) of this section.

(4) Subcontracts. The contractor or subcontractor shall insert in any subcontracts the clauses set forth in paragraph (b)(1) through (4) of this section and also a clause requiring the subcontractors to include these clauses in any lower tier subcontracts. The prime contractor shall be responsible for compliance by any subcontractor or lower tier subcontractor with the clauses set forth in paragraphs (b)(1) through (4) of this section.

(c) In addition to the clauses contained in Item 3, above, in any contract subject only to the Contract Work Hours and Safety Standards Act and not to any of the other statutes cited in 29 CFR 5.1, the Subrecipient shall insert a clause requiring that the contractor or subcontractor shall maintain payrolls and basic payroll records during the course of the work and shall preserve them for a period of three years from the completion of the contract for all laborers and mechanics, including guards and watchmen, working on the contract. Such records shall contain the name and address of each such employee, social security number, correct classifications, hourly rates of wages paid, daily and weekly number of hours worked, deductions made, and actual wages paid. Further, the Subrecipient shall insert in any such contract a clause providing that the records to be maintained under this paragraph shall be made available by the contractor or subcontractor for inspection, copying, or transcription by authorized representatives of the (write the name of agency) and the Department of Labor, and the contractor or subcontractor will permit such representatives to interview employees during working hours on the job.

5. Compliance Verification.

(a) The subrecipient shall periodically interview a sufficient number of employees entitled to DB prevailing wages (covered employees) to verify that contractors or subcontractors are paying the appropriate wage rates. As provided in 29 CFR 5.6(a)(6), all interviews must be conducted in confidence. The subrecipient must use Standard Form 1445 (SF 1445) or equivalent documentation to memorialize the interviews. Copies of the SF 1445 are available from EPA on request.

(b) The subrecipient shall establish and follow an interview schedule based on its assessment of the risks of noncompliance with DB posed by contractors or subcontractors and the duration of the contract or subcontract. Subrecipients must conduct more frequent interviews if the initial

interviews or other information indicates that there is a risk that the contractor or subcontractor is not complying with DB. Subrecipients shall immediately conduct necessary interviews in response to an alleged violation of the prevailing wage requirements. All interviews shall be conducted in confidence.

(c) The subrecipient shall periodically conduct spot checks of a representative sample of weekly payroll data to verify that contractors or subcontractors are paying the appropriate wage rates. The subrecipient shall establish and follow a spot check schedule based on its assessment of the risks of noncompliance with DB posed by contractors or subcontractors and the duration of the contract or subcontract. At a minimum, if practicable the subrecipient should spot check payroll data within two weeks of each contractor or subcontractor's submission of its initial payroll data and two weeks prior to the completion date the contract or subcontract. Subrecipients must conduct more frequent spot checks if the initial spot check or other information indicates that there is a risk that the contractor or subcontractor is not complying with DB . In addition, during the examinations the subrecipient shall verify evidence of fringe benefit plans and payments thereunder by contractors and subcontractors who claim credit for fringe benefit contributions.

(d) The subrecipient shall periodically review contractors and subcontractors use of apprentices and trainees to verify registration and certification with respect to apprenticeship and training programs approved by either the U.S Department of Labor or a state, as appropriate, and that contractors and subcontractors are not using disproportionate numbers of, laborers, trainees and apprentices. These reviews shall be conducted in accordance with the schedules for spot checks and interviews described in Item 5(b) and (c) above.

(e) Subrecipients must immediately report potential violations of the DB prevailing wage requirements to the EPA DB contact listed above and to the appropriate DOL Wage and Hour District Office listed at <http://www.dol.gov/whd/america2.htm> or its successor site.

DAVIS-BACON WAGE RATE

General Decision Number: KY150140 02/06/2015 KY140

Superseded General Decision Number: KY20140140

State: Kentucky

Construction Type: Heavy

Counties: Breckinridge, Caldwell, Carlisle, Crittenden, Fulton, Grayson, Hickman, Hopkins, Livingston, Muhlenberg, Ohio and Todd Counties in Kentucky.

HEAVY CONSTRUCTION PROJECTS (including sewer/water construction).

Note: Executive Order (EO) 13658 establishes an hourly minimum wage of \$10.10 for 2015 that applies to all contracts subject to the Davis-Bacon Act for which the solicitation is issued on or after January 1, 2015. If this contract is covered by the EO, the contractor must pay all workers in any classification listed on this wage determination at least \$10.10 (or the applicable wage rate listed on this wage determination, if it is higher) for all hours spent performing on the contract. The EO minimum wage rate will be adjusted annually. Additional information on contractor requirements and worker protections under the EO is available at www.dol.gov/whd/govcontracts.

Modification Number	Publication Date
0	01/02/2015
1	02/06/2015

ENGI0181-009 07/01/2014

	Rates	Fringes
POWER EQUIPMENT OPERATOR		
GROUP 1.....	\$ 28.85	14.15
GROUP 2.....	\$ 26.24	14.15
GROUP 3.....	\$ 26.65	14.15
GROUP 4.....	\$ 25.95	14.15

OPERATING ENGINEER CLASSIFICATIONS

GROUP 1 - Backhoe/Excavator/Trackhoe; Bulldozer; Crane; Drill; Grader/Blade; Loader; Mechanic; Scraper

GROUP 2 - Bobcat/Skid Steer/Skid Loader; Forklift; Tractor (50 H.P. or over)

GROUP 3 - Articulating Truck Operator

GROUP 4 - Oiler; Tractor (under 50 H.P.)

Operators on cranes with booms 150 feet and over (including jib) shall receive \$1.00 above Group 1 rate; 250 feet and over including jib shall receive \$1.50 above Class 1 rate. Combination Rate: All crane operators operating cranes,

where the length of the boom in combination with the length of the piling leads equal or exceeds 150 feet, shall receive \$1.00 above the Group 1 rate.

Employees assigned to work below ground level are to be paid 10% above basic wage rate. This does not apply to open cut work.

IRON0782-010 05/01/2014

	Rates	Fringes
IRONWORKER (Reinforcing & Structural)		
Projects over \$20,000,000.00.....	\$ 27.09	20.66
Projects under \$20,000,000.00.....	\$ 25.50	19.02

LABO0189-001 07/01/2014

	Rates	Fringes
LABORER		
Concrete Saw (Hand Held/Walk Behind).....	\$ 22.05	11.96

LABO0561-003 07/01/2014

	Rates	Fringes
LABORER		
Form Worker.....	\$ 21.61	12.65

LABO1214-001 07/01/2014

	Rates	Fringes
LABORER		
Backfiller, Carpenter		
Tender, Common or General,		
Concrete Worker, Dumpman,		
Fence Erection.....	\$ 21.50	12.26
Pipelayer & Tamper (Hand Held/Walk Behind).....	\$ 21.75	12.26

* UAVG-KY-0001 06/25/2014

	Rates	Fringes
LABORER: Grade Checker.....	\$ 21.68	11.38

SUKY2011-017 06/25/2014

	Rates	Fringes
CEMENT MASON/CONCRETE FINISHER...	\$ 20.96	10.53
ELECTRICIAN.....	\$ 32.35	2.18

LABORER: Flagger.....	\$ 18.31	8.89
OPERATOR: Boring Machine.....	\$ 25.35	13.00

WELDERS - Receive rate prescribed for craft performing operation to which welding is incidental.

Unlisted classifications needed for work not included within the scope of the classifications listed may be added after award only as provided in the labor standards contract clauses (29CFR 5.5 (a) (1) (ii)).

The body of each wage determination lists the classification and wage rates that have been found to be prevailing for the cited type(s) of construction in the area covered by the wage determination. The classifications are listed in alphabetical order of "identifiers" that indicate whether the particular rate is a union rate (current union negotiated rate for local), a survey rate (weighted average rate) or a union average rate (weighted union average rate).

Union Rate Identifiers

A four letter classification abbreviation identifier enclosed in dotted lines beginning with characters other than "SU" or "UAVG" denotes that the union classification and rate were prevailing for that classification in the survey. Example: PLUM0198-005 07/01/2014. PLUM is an abbreviation identifier of the union which prevailed in the survey for this classification, which in this example would be Plumbers. 0198 indicates the local union number or district council number where applicable, i.e., Plumbers Local 0198. The next number, 005 in the example, is an internal number used in processing the wage determination. 07/01/2014 is the effective date of the most current negotiated rate, which in this example is July 1, 2014.

Union prevailing wage rates are updated to reflect all rate changes in the collective bargaining agreement (CBA) governing this classification and rate.

Survey Rate Identifiers

Classifications listed under the "SU" identifier indicate that no one rate prevailed for this classification in the survey and the published rate is derived by computing a weighted average rate based on all the rates reported in the survey for that classification. As this weighted average rate includes all rates reported in the survey, it may include both union and non-union rates. Example: SULA2012-007 5/13/2014. SU indicates the rates are survey rates based on a weighted average

calculation of rates and are not majority rates. LA indicates the State of Louisiana. 2012 is the year of survey on which these classifications and rates are based. The next number, 007 in the example, is an internal number used in producing the wage determination. 5/13/2014 indicates the survey completion date for the classifications and rates under that identifier.

Survey wage rates are not updated and remain in effect until a new survey is conducted.

Union Average Rate Identifiers

Classification(s) listed under the UAVG identifier indicate that no single majority rate prevailed for those classifications; however, 100% of the data reported for the classifications was union data. EXAMPLE: UAVG-OH-0010 08/29/2014. UAVG indicates that the rate is a weighted union average rate. OH indicates the state. The next number, 0010 in the example, is an internal number used in producing the wage determination. 08/29/2014 indicates the survey completion date for the classifications and rates under that identifier.

A UAVG rate will be updated once a year, usually in January of each year, to reflect a weighted average of the current negotiated/CBA rate of the union locals from which the rate is based.

WAGE DETERMINATION APPEALS PROCESS

1.) Has there been an initial decision in the matter? This can be:

- * an existing published wage determination
- * a survey underlying a wage determination
- * a Wage and Hour Division letter setting forth a position on a wage determination matter
- * a conformance (additional classification and rate) ruling

On survey related matters, initial contact, including requests for summaries of surveys, should be with the Wage and Hour Regional Office for the area in which the survey was conducted because those Regional Offices have responsibility for the Davis-Bacon survey program. If the response from this initial contact is not satisfactory, then the process described in 2.) and 3.) should be followed.

With regard to any other matter not yet ripe for the formal process described here, initial contact should be with the Branch of Construction Wage Determinations. Write to:

Branch of Construction Wage Determinations
Wage and Hour Division
U.S. Department of Labor
200 Constitution Avenue, N.W.
Washington, DC 20210

2.) If the answer to the question in 1.) is yes, then an interested party (those affected by the action) can request review and reconsideration from the Wage and Hour Administrator (See 29 CFR Part 1.8 and 29 CFR Part 7). Write to:

Wage and Hour Administrator
U.S. Department of Labor
200 Constitution Avenue, N.W.
Washington, DC 20210

The request should be accompanied by a full statement of the interested party's position and by any information (wage payment data, project description, area practice material, etc.) that the requestor considers relevant to the issue.

3.) If the decision of the Administrator is not favorable, an interested party may appeal directly to the Administrative Review Board (formerly the Wage Appeals Board). Write to:

Administrative Review Board
U.S. Department of Labor
200 Constitution Avenue, N.W.
Washington, DC 20210

4.) All decisions by the Administrative Review Board are final.

=====
END OF GENERAL DECISION

**KENTUCKY DEPARTMENT OF LABOR
PREVAILING WAGE RATE**

NOTIFICATION OF PUBLIC WORKS PROJECT

TO: KY Labor Cabinet
Division of Employment Standards, Apprenticeship, and Mediation
1047 US 127 S – Suite 4
Frankfort KY 40601
FAX: 502-696-1897
EMAIL: Labor.DESAM@ky.gov

DATE: TBD

SUBJECT: NOTIFICATION OF PUBLIC WORKS PROJECT

The Kentucky Revised Statute 337.510 states that before advertising for bids or entering into any contract for construction of public works, every public authority shall notify the department in writing of the specific public work to be constructed, and shall ascertain from the department the prevailing rates of wages for each classification of laborers, workmen, and mechanics for the class of work called for in the construction of such public works in the locality where the work is to be performed.

Please be advised of the following:

COUNTY: Ohio ADVERTISING DATE: TBD

PUBLIC AUTHORITY: Ohio County Water District

PROJECT: Contract 15-01 - 16-inch North Water Transmission Line - Phase I

TYPE OF PROJECT: BUILDING HEAVY/HIGHWAY

SPECIFIC DESCRIPTION OF PROJECT:
Installation of approximately 15,875 L.F. of 16-inch water line from BCBC Tank to IPE Tank

APPROXIMATE COST: \$ 1,400,000

ARE FEDERAL FUNDS BEING USED? YES NO

HAS FEDERAL LAW ESTABLISHED WAGE RATES AND FILING REQUIREMENTS FOR THIS PROJECT? YES NO

DATES OF CONSTRUCTION: TBD to TBD

Please send the current prevailing wage schedule for the above county to:

NAME: J. Gregory Davenport, P.E. TITLE: Senior Vice President

COMPANY: J. R. Wauford & Company, Consulting Engineers, Inc.

ADDRESS: P. O. Box 140350, 2835 Lebanon Road

CITY: Nashville STATE: TN ZIP: 37214

PHONE: 615-883-3243 FAX: 613-391-3710 EMAIL: leighann@jrwauford.com

I understand that KRS 337.990, Subsection (13), provides that any public authority, public official, or member of a public authority who willfully fails to comply or to require compliance with KRS 337.505 to 337.550 shall be assessed a civil penalty of not less than \$100, nor more than \$1000 for each offense. Each day of violation shall constitute a separate offense. If a public authority, public official or member of a public authority willfully or negligently fails to comply with KRS 337.505 to KRS 337.550 and such failure results in damages, injury or loss to any person, the public authority, public official, or member of a public authority may be held liable in a civil action.

Signature Date

J. Gregory Davenport, P.E.

Printed Name

Detailed Specifications
2021 – June 2015

SECTION 1

GENERAL SCOPE AND SPECIAL PROVISIONS

1. Scope of Work

The work to be accomplished under these Detailed Specifications consists of furnishing all labor, materials, equipment and services necessary for the construction of Water System Improvements, Contract 15-01 – 16-inch North Water Transmission Line – Phase I for the Ohio County Water District. The work involved is in one (1) contract and consists of the following generally described work:

CONTRACT 15-01

16-INCH NORTH WATER TRANSMISSION LINE – PHASE I

- Three Lump Sum connections to existing 8-inch (1), 10-inch (1), and 12-inch (1) Water Lines
- 185 L.F. of 24-inch Steel Casing Pipe bored under Western Kentucky Parkway
- 195 L.F. of 16-inch RJDIP installed in 24-inch Steel Casing Pipe
- 3,450 L.F. of 16-inch Class 250 DIP
- 12,226 L.F. of 16-inch C-905 PVC
- 3 Each Fire Hydrant Assemblies
- 6 Each 16-inch Butterfly Valve Assemblies
- 11 Each 4-inch Air Release Valve Assemblies
- BCBC Tank Control Valve and Structure

2. Execution and Coordination of the Work

It is intended that the work covered by this Contract be done so as to cause the minimum interference with the normal operation of the existing facilities of the Ohio County Water District.

The Contractor shall be required to organize and schedule his work so as to keep the existing facilities in full operation during the construction period insofar as is consistent with the nature of the construction work to be performed.

The manner in which shutdowns will be made and the Contractor's work schedule are subject to the approval of the Owner and the Engineer. Although every effort will be made to cause the minimum amount of interference with the Contractor's work, the interest of the Ohio County Water District in regard to the existing facilities must always take precedence over the construction work.

THEREFORE, THE RIGHT IS RESERVED BY THE OWNER TO PUT ANY LINES OR OTHER FACILITIES THAT MAY BE SHUT DOWN FOR THE CONSTRUCTION WORK BACK INTO SERVICE WHEN AN EMERGENCY ARISES.

The Contractor must have sufficient materials, equipment, labor, and supervision available to accomplish the work required in the time allocated for any shutdown of the existing water system.

3. Temporary Traffic Control Plan

When work is conducted within the right-of-way of transportation agencies or city or county roadways, the Contractor shall provide temporary traffic control (TTC) in accordance with the Manual on Uniform Traffic Control Devices (MUTCD). TTC devices shall include but shall not be limited to signs, barricades, flagmen and channelization devices. The Contractor shall provide TTC for all roadway users including motorists, bicyclists and pedestrians. All TTC shall be in accordance with the Americans with Disabilities Act of 1990, Title II, Paragraph 35.130.

4. Time of Completion and Liquidated Damages

Time is of the essence on this contract and work on this contract shall be prosecuted in a timely manner.

Time of completion after notice to proceed will be as follows:

Contract 15-01 – Two Hundred Seventy (270) consecutive calendar days

If the work is not completed within the time specified, liquidated damages in the amount of \$1,000 per calendar day will be deducted from the compensation otherwise due to the Contractor(s) in accordance with the Contract Documents for each calendar day thereafter, Sundays and holidays included, that the work remains uncompleted.

The Contractor's attention is called to Article 4 of the General Conditions regarding contract completion date time extensions.

5. Guarantee

The Contractor(s) shall guarantee all work performed under this contract for a period of one year after the date of Substantial Completion in accordance with requirements of Paragraph 15.08 of the General Conditions.

Detailed Specifications
2021 – June 2015

6. Progress Schedule and Progress Meetings

The Contractor shall furnish five (5) copies of a suitable progress chart or schedule in graphical form showing the estimated schedule for the project as required in Article 2.05 of the General Conditions. After approval, the Contractor shall update the chart monthly showing the actual progress on the project for each specific item of work in relation to the estimated schedule.

FAILURE TO SUBMIT SAID PROGRESS SCHEDULE AND KEEP IT CURRENT MONTHLY SHALL BE GROUNDS FOR NONPAYMENT OF PARTIAL PAYMENT REQUESTS.

The Engineer and Owner may elect to conduct monthly progress meetings on-site with the Contractor, the Owner and the Engineer to discuss progress, any problems encountered and other appropriate subjects.

7. Initial Video Tapes and Progress Pictures

Before beginning the job, the Contractor shall make a video showing the status before construction has begun. The video shall be made, submitted and approved prior to the beginning of work. The Contractor shall submit two (2) copies of the video in DVD format.

The Contractor shall furnish progress pictures to the Engineer at the end of each month at the time the pay request is submitted; the pictures shall be taken as directed by the Engineer's representative. The pictures shall be approximately 8" x 10" in size. Pictures shall be of high professional quality, clearly showing the work and preferably not showing workmen or passersby. The name of the project, Contractor's name, and the date shall be shown on the back of each picture. Three (3) prints each of three (3) pictures shall be required per month. One (1) set of pictures shall be submitted via email in .JPG format. Each electronic file should be date and time stamped. File names shall describe what is shown in the picture. REQUEST BY THE CONTRACTOR FOR PARTIAL PAYMENTS WILL NOT BE CONSIDERED WITHOUT THE REQUIRED PROGRESS PICTURES.

After construction and clean-up are completed, the Contractor shall submit video in DVD format showing the cleaned up work.

8. Lines and Grades

The Engineer has established survey baselines for the work. Benchmarks were set at the time of the original survey, the locations and elevations of which are shown on the Plans. These benchmark elevations were checked and verified at the time of the original survey.

Detailed Specifications
2021 – June 2015

Where tie-ons to existing lines or structures are to be made, the actual inverts of the existing lines or elevations of existing structures shall be field checked for verification before construction begins.

Any apparent discrepancy or error discovered in these benchmark elevations shall be reported to the Engineer immediately at telephone number 865-984-9638. Written approval from the Engineer shall be obtained before any changes are made.

The Contractor's attention is called to Paragraph 5.05 of the General Conditions.

9. Lands, Rights-of-Way and Limits of Work (see Article 5 of the General Conditions)

a. Lands and Easements

In general, the work will be constructed on easements held by the Owner or on street rights-of-way owned by the Owner.

The Contractor shall be responsible for obtaining necessary work permits from the Ohio County Water District.

b. Limits of Work

The Contractor shall limit his work area and storage to the Owner's property and/or permanent utility easements shown on the Plans. The Contractor shall not encroach or dump excess or waste materials on property adjacent to the work sites unless written permission is first received from the affected property owner and a copy submitted to the Engineer. Where excess materials are to be dumped off-site, the Contractor shall furnish the Owner written evidence of the property owner's permission.

In connection with work performed on easements or adjacent to private property, the Contractor shall take all reasonable care to avoid damage to the property owners' buildings, grounds and facilities and shall be completely responsible for the repair of damage to same. It is intended that when construction is complete, the easements and the private property owners' facilities and grounds shall be restored to as good or better than original condition as possible.

Large trees or other facilities within the actual construction limits that cannot be preserved and replaced shall be removed by the Contractor. THE OWNER WILL ASSUME THE RESPONSIBILITY FOR SETTLING WITH THE PROPERTY OWNER FOR THE LOSS OF SAID TREES OR

Detailed Specifications
2021 – June 2015

FACILITIES WITHIN THE CONSTRUCTION AREA. THE CONTRACTOR IS RESPONSIBLE FOR ALL OTHER DAMAGES.

Reasonable care shall be taken during construction to avoid damage to vegetation. Ornamental shrubbery and tree branches shall be temporarily tied back, where appropriate, to minimize damage. Trees which receive damage to branches shall be trimmed of those branches to improve the appearance of the tree. Tree trunks receiving damage from equipment shall be treated with a tree dressing.

10. Restoration of Disturbed Areas in Connection with Work on or Adjacent to Private Property

In connection with work performed on or adjacent to private property, the Contractor(s) shall take all reasonable care to avoid damage to the property Owners' buildings, grounds and facilities and shall be completely responsible for the repair of damage to same. Fences, hedges, shrubs, etc., within the construction limits shall be carefully removed, preserved, and replaced when the construction is completed. Where ditches or excavations cross lawns, the sod shall be removed carefully and replaced when the backfilling has been completed. If sod is damaged or not handled properly, it shall be replaced with new sod equal to existing sod at the Contractor's expense. All unpaved areas, other than lawns, shall be graded, fertilized, and seeded when construction is completed in accordance with the requirements set out in Section 4 of these Detailed Specifications. It is intended that when construction is completed, the private property owners' facilities and grounds shall be restored to as near their original condition as possible.

Foundations adjacent to an excavation which is to be carried below the bottom of the foundation shall be supported by shoring, bracing, or underpinning, and the Contractor(s) shall be held strictly responsible for any damage to said foundation.

Work on rights-of-way of the State or Federal Highways, or Ohio County shall be considered work on Private Property. It shall be the Contractor's responsibility to obtain any necessary work permits.

11. Existing Utilities

Special precautions shall be taken by the Contractor to avoid damage to existing overhead and underground utilities owned and operated by the Owner or by public or private utility companies.

The Contractor shall contact Kentucky BUD at 1-800-752-6007 at least 72 business hours in advance of digging. Before proceeding with the work, the Contractor shall confer with all public or private utilities in the vicinity of the

Detailed Specifications
2021 – June 2015

construction work. The purpose of the conference or conferences shall be to notify said companies, agencies or departments of the proposed construction schedule, verify the location of and possible interference with the existing utilities, arrange for necessary suspension of service where possible and approved by the Utility, and make arrangements to locate and avoid interference with all utilities. The Engineer and Owner have no objection to the Contractor arranging for said Utility Companies, Agencies or Departments to locate and uncover their own utilities; however, the Contractor shall bear the entire responsibility for locating and avoiding or repairing damage to said existing utilities. WORK SHALL NOT PROCEED WITHOUT ALL UNDERGROUND UTILITIES BEING LOCATED AND MARKED.

The Contractor shall locate all unknown metallic hazards, namely buried pipe, metals, *etc.*, by using a pipe locator, or whatever better methods the Contractor may elect to use. All hazards should be located and marked with a stake in such manner as to notify the equipment operator of such hazard.

Where existing utilities or other underground structures are encountered, they shall not be displaced or molested unless necessary and approved by the Owner, and in such case they shall be replaced in as good or better condition than found as quickly as possible. All such utilities that are so damaged or molested shall be replaced at the Contractor's expense, unless in the opinion of the Engineer such damage was caused through no fault of the Contractor.

It is expected that the Contractor will be diligent in his efforts and use every possible means to locate existing utilities. Any claims for unavoidable damage, based on improper or unknown locations, will be thoroughly examined in light of the Contractor's efforts to locate the said utilities or obstructions prior to beginning construction.

12. Substantial Completion/Delays in Final Completion

See Paragraph 15.03 of the General Conditions.

In order to allow all outstanding incomplete items to be completed during the initial start-up and operating period, a semi-final inspection will be made upon request by the Contractor after the beginning of the initial start-up period. In no event will the date of substantial completion of the Contract for purposes of determining payment of the liquidated damages be set before the beginning of the initial start-up period.

13. Reference to Kentucky Transportation Cabinet, Department of Highways Standard Specifications for Road and Bridge Construction

Where items are referred as being in conformance with Kentucky Transportation Cabinet Specifications, certain materials, equipment and construction methods

Detailed Specifications
2021 – June 2015

shall be in accordance with Section 805 of the Kentucky Transportation Cabinet, Department of Highways, Standard Specifications for Road and Bridge Construction, 2008 edition and any revisions or addendum issued for subject specification.

14. Undesirable Workmen

The Engineer reserves the right, but in so doing does not assume responsibility to make a judgment (the primary responsibility rests upon the Contractor), to remove inept or uncooperative servicemen as "Undesirable Workmen".

15. Protection of Roadways On and Off-Site

In the hauling of materials and/or equipment to and from the site of the work, the Contractor shall take care to protect county roads, highways, parking areas and/or city streets. The Contractor shall be responsible for repair of highways, roads, parking areas or streets damaged by his operations (or operations of his subcontractors) and shall repair said damage to the original condition. If repair to the original condition is not practical or possible, the Contractor shall be responsible for obtaining proper release from the owner of the damaged roadway.

16. Shop Drawings (See Paragraph 7.16 of the General Conditions)

The Contractor shall at a minimum submit six (6) detailed shop drawings and/or certifications for each of the following items prior to incorporating these items into the construction:

- a. Pipe including Fittings
- b. Valves and Boxes
- c. Air Release Valve Assembly and Boxes
- d. BCBC Tank Vault
- e. Fire Hydrants
- f. Traffic Control Plan
- g. Written Work Plan
- h. Progress Schedule

SHOP DRAWINGS SENT TO THE ENGINEER BY FAX MACHINE OR E-MAIL WILL NOT BE CONSIDERED AN OFFICIAL SUBMITTAL UNTIL THE ORIGINALS ARE RECEIVED.

REJECTION OF THE SAME DRAWING ON THREE (3) SEPARATE OCCASIONS WILL CONSTITUTE GROUNDS FOR TOTAL REJECTION OF THE PROPOSED EQUIPMENT MANUFACTURER OR SUPPLIER AS BEING UNABLE OR UNWILLING TO MEET THESE DETAILED SPECIFICATIONS.

Detailed Specifications
2021 – June 2015

Shop drawings shall be checked by the Contractor and evidence of such checking shall be indicated thereon. The Contractor shall be completely responsible for accuracy, completeness, compliance with Plans and Specifications, and compatibility, the Engineer's approval notwithstanding.

WORK SHALL BE PERFORMED ONLY BY USE OF APPROVED SHOP DRAWINGS. THE CONTRACTOR SHALL PLAINLY MARK ON HIS SUBMITTAL THE ITEM OR ITEMS FOR WHICH HE IS REQUESTING APPROVAL. FAILURE TO DO SO WILL GIVE THE ENGINEER THE RIGHT TO EITHER REJECT THE SUBMITTAL OR SELECT THE ITEM OF HIS CHOICE AT NO ADDITIONAL COST TO THE OWNER.

The Engineer will attempt to take action on all COMPLETE shop drawings within ten (10) working days of their receipt; however, the Engineer reserves the right to take up to twenty-one (21) calendar days from their receipt to take action on said submittal. The Contractor shall be solely responsible for timely submission of shop drawings based on the above and no extras for time or costs will be acceptable.

17. Materials or Equipment to be Furnished (see Paragraph 7.04 of the General Conditions)

Where the specifications state "equal to" followed by a brand name or model, a standard of quality is being set. The naming of a brand or model is a matter of convenience to avoid writing a volume. Other brands or equipment under this category may be submitted at the shop drawing stage of construction. The Engineer will consider other products on the basis of materials of construction, weight, function, size (it must fit the space provided), service history and electrical and mechanical characteristics.

Where the specifications state one or more model numbers and manufacturers followed by the words "or approved equal" the meaning is that the product(s) specified is acceptable and that while there may be other products that are acceptable the only way to be assured is to submit the desired substitution during the BID PROCESS and receive an affirmative answer in the form of a letter or an addendum. The Engineer will consider the factors previously described in making the determination.

Unless otherwise specified, all materials shall be the best of their respective kinds and shall be in all cases fully equal to approved samples. The Engineer shall have the right to require the use of such specifically designated material, article, or process. The Engineer, where practical, may require submission of actual samples of materials or products.

Detailed Specifications
2021 – June 2015

18. Permits, Codes, Agreements and/or Contracts with Private Utilities

The Contractor shall make application for, obtain, and pay for all licenses, permits, agreements, and/or contracts with private utility companies and shall pay all fees and charges in connection therewith.

19. Utilities Required by Contractor

All electric current and/or utility service required by the Contractor shall be furnished at his own expense.

20. Blasting

Blasting will not be allowed on this project.

21. Subsurface Conditions/Site Conditions

As provided by Paragraph 5.03 of the General Conditions, subsurface conditions are unknown unless a Geotechnical Report is included at the end of Section 1.

22. Connecting to Existing Lines

The Contractor shall make the required connections to existing lines and structures as shown on the Plans and as specified in these Detailed Specifications. Refer to Paragraph 2. Execution and Coordination of the Work and Paragraph 8. Lines and Grades of this Section of these Detailed Specifications.

The work of connecting new lines to existing lines and new structures to existing structures is the responsibility of the Contractor and is NOT a separate pay item unless indicated otherwise in the BID FORM; it being the intent of these Detailed Specifications to provide a complete operable facility.

23. Water and Uplift

The Contractor(s) shall, by the use of well points, pumps or other approved methods, prevent the accumulation of water in excavated areas. Should water accumulate, it shall be promptly removed. The Contractor(s) shall also provide for dewatering areas adjacent to structures or lines to prevent uplift during construction operations. The Contractor(s) will be held responsible for any damage due to uplift of such structures or lines and to existing structures during construction operations.

24. Occupational Safety and Health Act

The Contractor's attention is called to Paragraph 7.12 of the General Conditions.

Detailed Specifications
2021 – June 2015

25. Chemical Requirements

All chemicals used during project construction or furnished for project operation, whether herbicide, pesticide, disinfectant, polymer, reactant or of other classifications, must show approval of either EPA or USDA. Use of all such chemicals and disposal of residues shall be in strict conformance with the Material Safety Data Sheets.

26. Disposal of Demolition Debris

The Contractor shall be responsible for the disposal of demolition debris created by this project. The Contractor shall furnish the Owner and Engineer with written evidence of the property owner's permission.

27. Engineer's Authority

See Article 10 of the General Conditions.

28. Confined Spaces

During the construction of the facilities to be built under the terms of this contract, it may be necessary for the OWNER'S or the ENGINEER'S representative(s) to enter "confined space(s)", as defined by OSHA Regulations, in order to observe the work of the Contractor and/or in order to determine compliance with the terms of the contract. The Contractor shall provide the proper "Permit", the "Attendant", and/or the "Entry-Supervisor", the testing safety and emergency equipment and all other means of compliance with OSHA regulations. The OWNER or the ENGINEER will provide general training to their respective proposed "authorized Entrant(s)" who are employees of the OWNER or the ENGINEER, however the Contractor shall provide any specialized training required for the equipment furnished, the Contractor's Permit System or any other condition special to the work to be performed. The Contractor shall submit a copy of its written Permit System prior to the commencement of construction and shall be fully responsible for compliance with the appropriate regulations.

29. Field Office

The Contractor shall establish and maintain a field office on the project and have available at that office a responsible representative who can officially receive comments from the Engineer. The Contractor shall have one complete up-to-date set of Plans and Specifications and a Kentucky Division of Water approved set in this office at all times. The office shall be provided with e-mail service, toilet facilities, lights and heat. It shall also contain adequate space and facilities for the use of the Engineer's Resident Project Representative, including desk or table, chair and filing cabinet.

Detailed Specifications
2021 – June 2015

30. Applicability of Governing Standards

The latest version of any standard listed in these Detailed Specifications as of the bid date shall apply. In cases that an incorrect revision year is listed, it shall not apply - the latest version as of the bid date shall apply.

31. Project Sign

A project sign is not required.

32. Flooding

Some of the work is to be conducted in areas subject to flooding. Obstructions to flow which would cause flooding in the event of heavy rainfall shall be avoided by the Contractor(s). Flood insurance under PL 93-234 is not required.

33. Noise, Odor and Dust Control

The work hereunder may be performed within a residential area of Ohio County. The Contractor shall be responsible for noise, odor and dust abatement procedures and shall not commence work in these areas before 7:00 a.m. local prevailing time.

34. Work Hours

No night, weekend or Holiday work requiring the presence of the Engineer or Owner representatives will be permitted, except in case of emergency, and then only to the extent such work is necessary for protection of the work, and only with written approval of the Engineer. This clause shall not apply on such work which can only be performed at night.

35. Final Clean-Up

Before the work is considered as complete, all rubbish and unused material due to or connected with the construction shall be removed and the premises left in a condition satisfactory to the Engineer. Streets, curbs, crosswalks, pavements, sidewalks, fences and other public and private property disturbed or damaged shall be restored to their former condition at the Contractor's expense. Final acceptance will be withheld until such work is completed.

36. Utility Line Crossings of State Highways

All utility crossings of State Highways shall adhere to the terms and conditions in the encroachment permit as established by the Kentucky Transportation Cabinet Department of Highways permit requirements. The Contractor shall be responsible for complying with conditions of the permit.

Detailed Specifications
2021 – June 2015

37. Temporary Project Water Pollution Control (Soil Erosion)

Temporary pollution control provisions shall be taken to avoid damage to embankments and cut slopes and to avoid transport of sediment to adjacent property owners and/or streams.

Pollution and erosion control methods shall include but are not limited to the following:

a. Temporary Berms

Temporary berms shall be constructed of compacted soil with or without a shallow ditch at the top of all excavation and embankment slopes to prevent excessive erosion until the slopes are stabilized.

b. Temporary Slope Drains

Temporary slope drains shall be stone gutters, fiber mats, plastic sheets, concrete or asphalt gutters, half-round pipe, metal pipe, plastic pipe, sod or other material acceptable to the Engineer that may be used to carry water down slopes to reduce erosion.

c. Temporary Silt Fences

Temporary silt fences with baled hay or straw shall be placed on the natural ground, at the bottom of fill slopes, in ditches or other areas where siltation is a problem or where shown on the Plans.

Silt fences are constructed of wire mesh fence with a covering of filter cloth composed of burlap, plastic filter fabric or some other suitable material on the upper grade side of the fence and anchored into the soil.

Bales shall be either hay or straw containing five (5) cubic feet or more of material.

The above listed pollution and erosion control methods shall be used at the discretion of the Contractor or where directed by the Engineer. Temporary pollution control is NOT a separate pay item.

The Contractor shall be solely and strictly liable for any violations of State or Federal water pollution laws, regulations, or standards caused during construction by the Contractor's forces or subcontractors and shall pay any penalties levied by any party due to said violations.

The Contractor shall maintain all areas where excavation and backfill construction operations are being performed or have been performed in order

Detailed Specifications
2021 – June 2015

that siltation, erosion and other forms of stormwater pollution caused by construction activities will be kept to a minimum during construction. The Engineer will prepare the Stormwater Pollution Prevention Plan (SWPPP) and obtain approval thereof from the Kentucky Division of Water if required. The Contractor is responsible for complying with said SWPPP.

Storm Water Pollution Prevention Plan

**STORM WATER POLLUTION
PREVENTION PLAN**

**WATER SYSTEM IMPROVEMENTS
16-INCH NORTH WATER TRANSMISSION LINE –
PHASE I**

FOR THE

OHIO COUNTY WATER DISTRICT

CONTRACT NO: 15-01

JUNE 2015

JRWCO JOB NO. 2021

PREPARED BY:

**J.R. Wauford & Company Consulting Engineers, Inc.
2835 LEBANON ROAD
NASHVILLE, TENNESSEE 37214**

Table of Contents

1. Owner Developer	1
2. Contractor	1
3. Description and General Sequence of Construction Activities	1
4. Timetable	1
5. Permits	1
6. Inspections and Reports	2
7. Spill Prevention and Containment	3
8. Erosion and Sediment Controls	3
9. Updated Plan	5
10. Stabilization Requirements	5

1. Owner/Developer

The owner/developer of the property is the Ohio County Water District. Walt Beasley of the Ohio County Water District, is the contact for the owner/developer.

2. Contractor

The Owner will contract the services of a licensed Contractor to construct Contract 15-01. Once Contractors are selected by the Owner, a Notice of Intent shall be submitted to the Division by the Contractor.

The Contractor constructing Contract 05-01 shall be responsible for all regulatory compliance associated with the construction.

3. Description and General Sequence of Construction Activities

The work to be performed by the contract: Water System Improvements for the Ohio County Water District consists of the following general scope:

Contract 15-01:

- a. Erecting, maintaining, and removing temporary erosion control measures as required by the contract documents and regulatory permits.
- b. Installing approximately 15,876 ± L.F. of 16-inch water line.
- c. Establishing a vegetative cover on all disturbed areas of the construction site.

4. Timetable

Construction is scheduled to begin in Fall 2015 and conclude in Summer 2016.

5. Permits

The total area to be disturbed is approximately 14.6 acres. This is based on assumed disturbance width of 40 feet for the 16-inch water line. A Notice of Intent for coverage shall be submitted to the Kentucky Department for Environmental Protection, Division of Water by the Contractor for this project.

6. Inspections and Reports

The contractor shall have a designated, qualified individual responsible for performing an erosion control inspection twice every calendar week and erosion control inspections after rainfall events. Inspections will cover, at a minimum, all disturbed areas that have not undergone final stabilization and temporary and permanent erosion control measures. Inspections of erosion prevention and sediment control measures and outfall points will be conducted with the purpose of determining whether erosion prevention and sediment control measures are effective in preventing impacts to receiving waters, are properly installed, and properly maintained. Visual inspections shall include the following:

- a. erosion prevention measures;
- b. sediment control measures;
- c. other site management practices and points of site egress;
- d. disturbed areas;
- e. areas used for storage of materials exposed to rainfall; and
- f. discharge points.

The contractor shall be responsible for documenting the inspection which shall include:

- a. date of inspection;
- b. name and title of inspector;
- c. weather information since last inspection, including duration of each storm event, amount of rainfall, and beginning of each event;
- d. weather conditions and discharge occurring at time of inspection;
- e. location of discharges of sediment from site;
- f. location of sediment control measures, erosion control measures, and other practices that require maintenance;
- g. location of erosion prevention measures, sediment control measures, and other practices that failed to operate;

- h. location where additional erosion prevention measures, sediment control measures or other practices are needed;
- i. identification of any actions taken in response to inspection findings;
- j. identification of any incidentals that are non-compliant with SWPPP;
- k. certification of site if no incidentals of non-compliance of SWPPP are found; and
- l. signature in accordance with 401 KAR 5:065, Section I.

Inspection documentation shall be maintained on site and made available upon request. Inspection reports shall be submitted to the division within 10 days of the request. Areas of the site that have undergone temporary or final stabilization shall be inspected at least once a month until coverage is terminated.

7. Spill Prevention and Containment

Fueling – any drippings or spillage of fuel must be removed at the end of the day. Contaminated soil must be placed on heavy plastic and covered to prevent contact with storm water. All fuel tanks must be in a containment area.

Chemicals – Oils, solvents, and/or other vehicle fluids must be kept in a contained area. Any spill of more than two gallons must be reported to an on-site supervisor and contained promptly. Oil cans and filters must be contained and disposed of by the contractor. No other chemicals are to be stored on the site.

Litter – The contractors are responsible for litter control for trash generated by the construction crews. The contractors shall perform litter control on a daily basis and prior to anticipated storm events.

Concrete – Rainfall exposure to freshly placed concrete shall be limited to prevent runoff.

8. Erosion and Sediment Controls

Temporary silt fences utilizing filter cloth with baled hay or straw shall be placed on the natural ground, at the bottom of fill slopes, in ditches or other areas where siltation is likely to occur. Silt fence should be placed on the contour with the ends turned upslope so that a certain depth of storm water may be retained in front of the silt fence. These structures shall be installed as depicted in the “Temporary Silt Fence”.

Routine maintenance of temporary erosion and sediment control structures is the responsibility of the contractor during the construction phase of the project.

Routine maintenance of temporary erosion and sediment controls includes, but is not limited to, the following:

- a. visually inspect all silt fencing twice weekly, in addition to before and after anticipated rainfall event, to ensure proper functioning;
- b. repair any silt fencing that was found during any visual inspection to require repairs; and
- c. removal and proper disposal of built-up sediment from silt fencing when the sediment reaches one third of the height of the silt fence.

If necessary to wash equipment to remove mud, the water must be diverted to an area for settling and filtration through vegetation. The use of soaps will not be allowed.

Topsoil removed from the area and not replaced in the same day shall be stockpiled within a silt fence area boundary.

Permanent soil stabilization with perennial vegetation shall be applied to all disturbed areas as soon as practicable after final grading.

The paved roads adjacent to the construction site shall be swept as required to remove any excess mud, dirt and/or rock tracked from the site. If sediment escapes the construction site, off-site accumulations of sediment must be removed within an appropriate time frame so that the sediment is not washed into streams, streets, and/or storm drains. In the event sediment escapes the construction site and accumulates onto private property, the contractor shall be responsible for obtaining permission from the private property owner to remove the accumulated sediment and shall be responsible for obtaining a written release from the property owner indicating that the property was restored to its original condition.

Disturbance will be kept to a minimum by implementing the following:

- a. only disturbing a portion of the project where phased construction is occurring;
- b. preventing clearing and grading events from being exposed to prolonged rainfall; and
- c. keeping the overall area of disturbed coverage to a minimum as outlined in specifications and plans.

The Storm Water Pollution Prevention Plan is prepared as a condition of the KPDES General Permit for Storm Water Discharges Associated with construction Activity.

The Storm Water Pollution Prevention Plan is to be kept at the project site.

9. Updated Plan

The Stormwater Pollution Prevention Plan (SWPPP) shall be amended, revised or updated if any of the following occur:

- a. erosion prevention measures, sediment control measures or other practices are significantly modified in response to a change in the project; or
- b. erosion prevention measures, sediment control measures, or other practices are found by staff or local, state, or federal officials to be ineffective in eliminating or minimizing pollutants in stormwater discharges,

Changes to the SWPPP shall be made before the next storm event whenever practicable.

10. Stabilization Requirements

Final stabilization practices shall be initiated no later than 14 days after completion of construction, or where construction has been suspended for more than 180 days.

Project Location Map

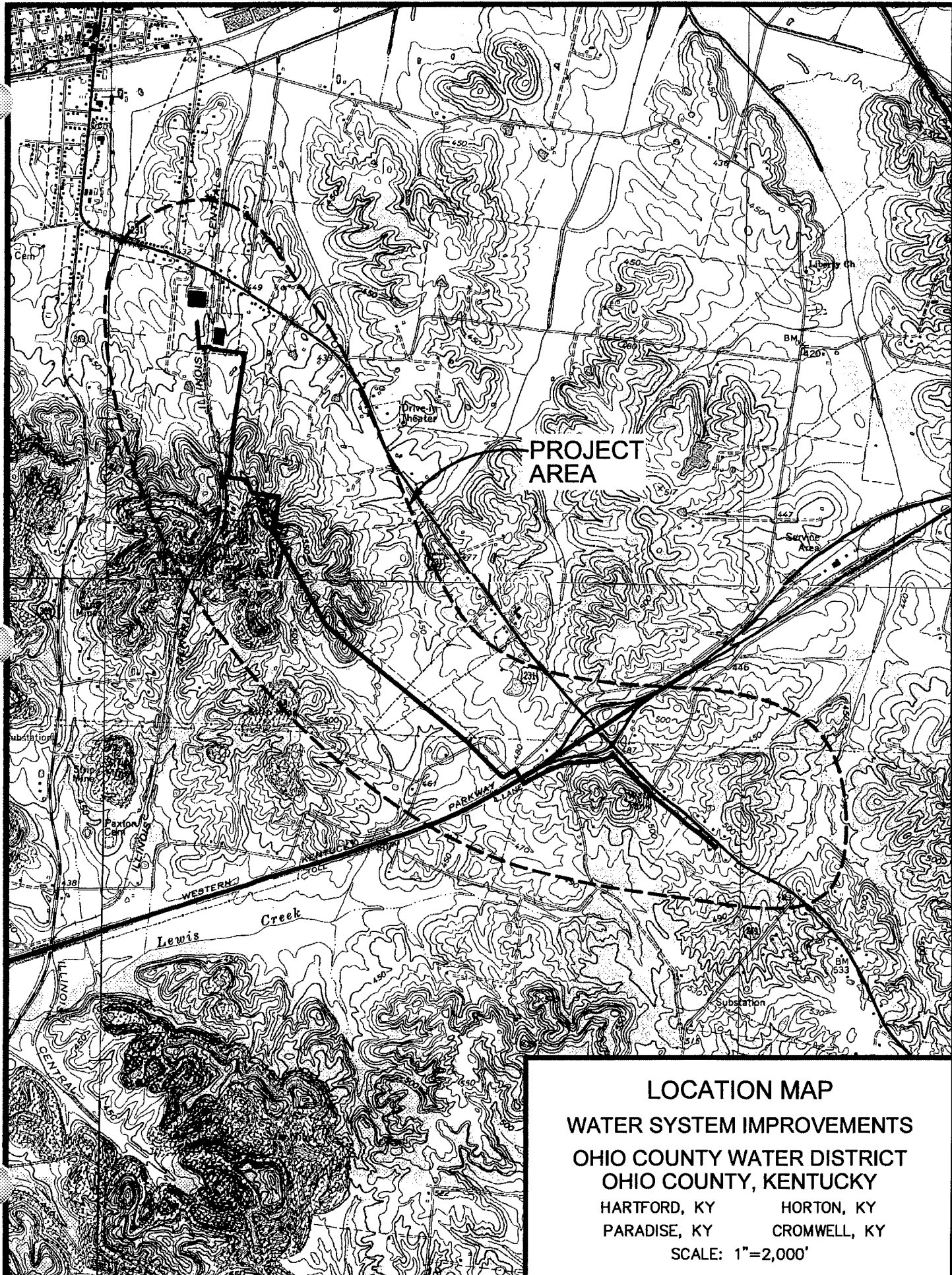

PROJECT AREA

LOCATION MAP
WATER SYSTEM IMPROVEMENTS
OHIO COUNTY WATER DISTRICT
OHIO COUNTY, KENTUCKY
HARTFORD, KY HORTON, KY
PARADISE, KY CROMWELL, KY
SCALE: 1"=2,000'

Erosion Control Measures

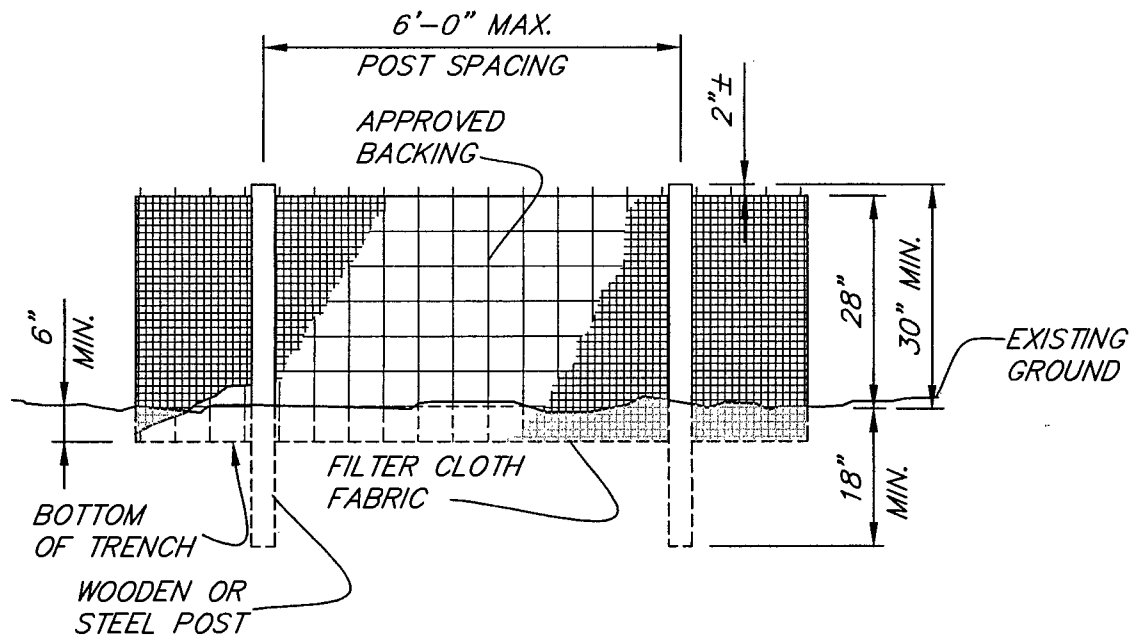

ELEVATION

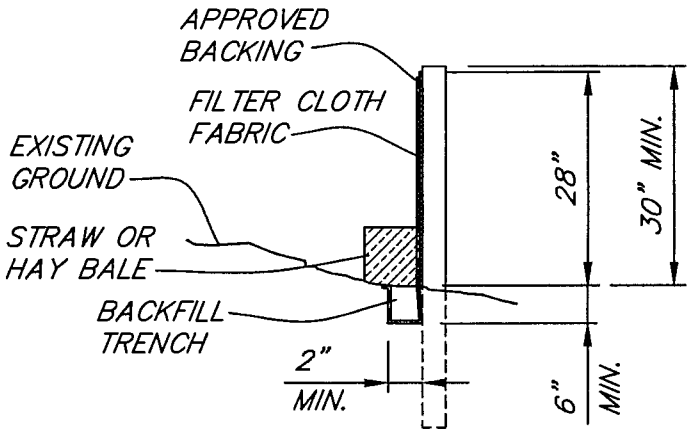

SECTION

NOTES:

1. FILTER CLOTH SHALL HAVE APPROVED BACKING OR A BUILT-IN REINFORCED STRUCTURE AS RECOMMENDED BY THE MANUFACTURER TO SUPPORT THE FILTER CLOTH.
2. A PREASSEMBLED SILT FENCE MEETING THE REQUIREMENTS OF THIS DRAWING IS ACCEPTABLE IN LIEU OF A FIELD CONSTRUCTED SILT FENCE
3. SEE STORM WATER POLLUTION PREVENTION PLAN (SWPPP) IN SPECIFICATIONS FOR FURTHER DETAILS AND REQUIREMENTS.

STANDARD TEMPORARY SILT FENCE

FORM NOI-SWCA

SECTION V – DISCHARGE TO AN MS4			
Name of MS4:		Date of application /notification to the MS4 for construction site coverage:	
Number of discharge points:	Location of each discharge point: Latitude (decimal degrees):*	Longitude (decimal degrees):*	
SECTION VI – CONSTRUCTION ACTIVITIES IN OR ALONG A WATER BODY			
Will the project require construction activities in a water body or the riparian zone: <input type="checkbox"/> Yes <input type="checkbox"/> No			
If yes, describe scope of activity:			
Is a Clean Water Act 404 permit required: <input type="checkbox"/> Yes <input type="checkbox"/> No		Is a Clean Water Act 401 Water Quality Certification required: <input type="checkbox"/> Yes <input type="checkbox"/> No	
SECTION VII – NOI PREPARER INFORMATION			
First Name:*	Last Name:*	Phone :*	eMail Address:*
Mailing Address:*	City:*	State:*	Zip Code:*
SECTION VIII – ATTACHMENTS			
Attach a full size color USGS 7½-minute quadrangle map with the facility site clearly marked. USGS maps may be obtained from the University of Kentucky, Mines and Minerals Bldg. Room 106, Lexington, Kentucky 40506. Phone number (859) 257-3896.			
SECTION IX – CERTIFICATION			
I certify under penalty of law that this document and all attachments were prepared under my direction or supervision in accordance with a system designed to assure that qualified personnel properly gather and evaluate the information submitted. Based on my inquiry of the person or persons who manage the system, or those persons directly responsible for gathering the information submitted is, to the best of my knowledge and belief, true, accurate, and complete. I am aware that there are significant penalties for submitting false information, including the possibility of fine and imprisonment for knowing violations.			
Signature:*		First Name:*	Last Name:*
Phone:*	eMail Address:	Date:*	

This completed application form and attachments should be sent to: SWP Branch, Division of Water, 200 Fair Oaks, Frankfort, Kentucky 40601. Questions should be directed to: SWP Branch, Operational Permits Section at (502) 564-3410.

**KENTUCKY POLLUTANT DISCHARGE ELIMINATION SYSTEM
FORM NOI-SWCA – INSTRUCTIONS**

WHO MUST FILE A NOTICE OF INTENT (NOI) FORM

Federal law at 40 CFR Part 122 prohibits point source discharges of stormwater associated with industrial activity to a water body of the Commonwealth of Kentucky without a Kentucky Pollutant Discharge Elimination System (KPDES) permit. The operator of an industrial activity that has such a storm water discharge must submit a NOI to obtain coverage under the KPDES Storm Water General Permit. If you have questions about whether you need a permit under the KPDES Storm Water program, or if you need information as to whether a particular program is administered by the state agency, call the Storm Water Contact, Operational Permits Section, Kentucky Division of Water at (502) 564-3410.

WHERE TO FILE NOI FORM

NOIs must be sent to the following address or submitted in on-line at <https://dep.gateway.ky.gov/eForms/Default.aspx?FormID=3>:

Operational Permits Section
SWP Branch, Division of Water
200 Fair Oaks Lane
Frankfort, KY 40601

Electronic NOI-SWCAs are to be submitted a minimum of seven (7) working days prior to commencement of construction related activities. Paper NOI-SWCAs are to be submitted a minimum of thirty (30) working days prior to commencement of construction related activities.

COMPLETING THE FORM

Enter information in the appropriate areas only. (*) denotes a required field. Enter N/A (Not Applicable) for fields that are required but do not apply to your submission. If you have any questions regarding the completion of this form call the Storm Water Contact, Operational Permits Section, at (502) 564-3410.

SECTION I – FACILITY OPERATOR INFORMATION

Operator Name(s): Enter the name or names of all operators applying for coverage under KYR10 using this NOI.
Mailing Address, City, State, and Zip Code: Provide the mailing address of the primary operator
Phone No.: Provide the telephone numbers of the person who is responsible for the operation.
Status of Owner/Operator: Select the appropriate legal status of the operator of the facility from the dropdown list.

Federal
Public (other than federal or state)
State
Private

SECTION II – FACILITY/SITE LOCATION INFORMATION

Name of Project: Provide the name of the project.
Physical Address, City, State, Zip Code and County: Provide the physical address of the project.
Latitude/Longitude: Provide the general site latitude and longitude of the operation.
SIC Code: Enter the Standard Industrial Code for the project

SECTION III – SITE ACTIVITY INFORMATION

For single projects provide the following information:

Total number of acres in project: Indicate the total acreage of the project including both disturbed and undisturbed areas.
Total number of acres to be disturbed: Indicate the total number of acres of the project to be disturbed.
Anticipated start date: Indicate the approximate date of when construction activities will begin.
Anticipated completion date: Indicated the approximate date of when final stabilization will be achieved.

For common plans of development provide the following information:

Total number of acres in project: Indicate the total acreage of the project including both disturbed and undisturbed areas.
Number of individual lots in development, if applicable: Indicate the number of individual lots or unit in the common plan of development
Number of lots to be developed: Indicate the number of lots that you intend to develop.
Total acreage of lots intended to develop: Indicate the total acreage of the lots you intend to develop
Total acreage intended to disturb: Indicate the total acreage of the lots you intend to disturb
Number of acres intended to disturb at any one time: Indicate the maximum number of acres to be disturbed at any one time.
Anticipated start date: Indicate the approximate date of when construction activities will begin.
Anticipated completion date: Indicated the approximate date of when final stabilization will be achieved.
List of contractors: Provide the names of all known contractors that will be working on site.

**KENTUCKY POLLUTANT DISCHARGE ELIMINATION SYSTEM
FORM NOI-SWCA – INSTRUCTIONS**

SECTION IV – IF THE PERMITTED SITE DISCHARGES TO A WATER BODY THE FOLLOWING INFORMATION IS REQUIRED

Name of Receiving Water: Provide the names of the each water body receiving discharges from the site. Provide only official USGS names do not provide local names

Anticipated number of discharge points: Indicate the number of discharge points to each receiving water body.

Location of anticipated discharge points: Provide the latitude and longitude of each discharge point. Add points as necessary.

Receiving Water Body Stream Use Designation: Check all appropriate boxes

Antidegradation Categorization: Select from the drop down box one of the following:

Outstanding National Resource Water

Exceptional Water

High Quality Water

Impaired Water

SECTION V – IF THE PERMITTED SITE DISCHARGES TO A MS4 THE FOLLOWING INFORMATION IS REQUIRED

Name of MS4: Provide the name of the MS4 to which the activity will discharge

Number of discharge points to the MS4: Indicate the number of discharge points

Location of each discharge point: Provide the latitude and longitude of each discharge point. Add points as necessary

Date of application/notification to the MS4 for construction site permit coverage: Indicate the date the MS4 has or will be notified.

SECTION VI – CONSTRUCTION ACTIVITIES IN OR ALONG A WATER BODY

Will the project require construction activities in a water body or the riparian zone: Select Yes or No from the drop down box.

If Yes, describe scope of activity: Provide a brief description of the activity (ics) that will take place in the water body or the riparian zone.

Is a Clean Water Act 404 permit required: Select Yes or No from the drop down box.

Is a Clean Water Act 401 Water Quality Certification required: Select Yes or No from the drop down box.

SECTION VII – NOI PREPARER INFORMATION

Provide the name, mailing address, telephone number and eMail address of the person preparing the NOI.

SECTION VIII – Attachments

Attach a USGS topographic map indicating the location of the activity and the proposed discharge points.

SECTION IX – CERTIFICATION

Provide the name, mailing address, telephone number and eMail address of the person who is responsible for the activity

Signature: Provide full name of the responsibility party. This will constitute a signature.

The NOI must be signed as follows:

Corporation: by a principal executive officer of at least the level of vice president

Partnership or sole proprietorship: by a general partner or the proprietor respectively

KPDES FORM NOT-SWCA

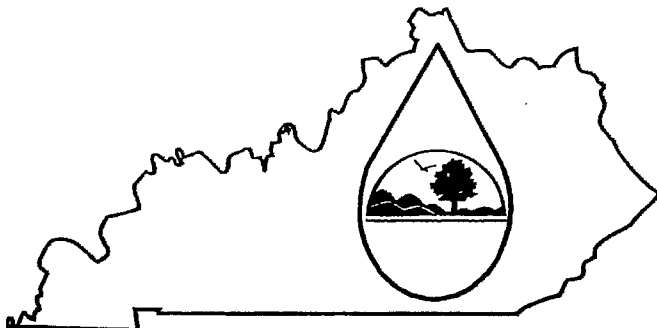
	<p style="text-align: center;">Kentucky Pollutant Discharge Elimination System (KPDES)</p> <p style="text-align: center;">NOTICE OF TERMINATION (NOT) of Coverage Under the KPDES General Permit for Storm Water Discharges Associated with Construction Activity</p>
---	--

Submission of this Notice of Termination constitutes notice that the party identified in Section II of this form is no longer authorized to discharge storm water associated with construction activity under the KPDES program.

ALL NECESSARY INFORMATION MUST BE PROVIDED ON THIS FORM.

(Please see instructions on back before completing this form.)

I. PERMIT INFORMATION	
KPDES Storm Water General Permit Number:	
Check here if you are no longer the Operator of the Facility: <input type="checkbox"/>	
Check here if the Storm Water Discharge is Being Terminated: <input type="checkbox"/>	
II. FACILITY OPERATOR INFORMATION	
Name:	
Address:	
City/ State/Zip Code:	
Telephone Number:	
III. FACILITY/SITE LOCATION INFORMATION	
Name:	
Address:	
Is this part of a larger common plan of development: <input type="checkbox"/> yes <input type="checkbox"/> no	
Name of Main Contractor:	
Lot Number:	of
Address of Lot(s):	
City/County/State/Zip Code:	

Certification: I certify under penalty of law that all storm water discharges associated with construction activity from the identified site that are authorized by a KPDES general permit have been eliminated or that I am no longer the operator of the construction site. I understand that by submitting this Notice of Termination, I am no longer authorized to discharge storm water associated with construction activity under this general permit, and that discharging pollutants in storm water associated with construction activity of waters of the Commonwealth is unlawful under the Clean Water Act and Kentucky Regulations where the discharge is not authorized by a KPDES permit. I also understand that the submittal of this Notice of Termination does not release an operator from liability for any violations of this permit or the Kentucky Revised Statutes.

NAME (Print or Type)	TITLE
SIGNATURE	DATE

INSTRUCTIONS
NOTICE OF TERMINATION (NOT) OF COVERAGE UNDER THE KPDES GENERAL PERMIT
FOR STORM WATER DISCHARGES ASSOCIATED WITH CONSTRUCTION ACTIVITY

Who May File a Notice of Termination (NOT) Form

Permittees who are presently covered under the Kentucky Pollutant Discharge Elimination System (KPDES) General Permit for Storm Water Discharges Associated with Construction Activity may submit a Notice of Termination (NOT) form when their facilities no longer have any storm water discharges associated with construction activity as defined in the storm water regulations at 40 CFR 122.26 (b)(14), or when they are no longer the operator of the facilities.

Elimination of all storm water discharges associated with industrial activity occurs when disturbed soils at the construction site have been finally stabilized and temporary erosion and sediment control measures have been removed or will be removed at an appropriate time, or that all storm water discharges associated with industrial activity from the construction site that are authorized by a KPDES general permit have otherwise been eliminated. Final stabilization means that all soil-disturbing activities at the site have been completed, and that a uniform perennial vegetative cover with a density of 70% of the cover for unpaved areas and areas not covered by permanent structures has been established, or equivalent permanent stabilization measures (such as the use of riprap, gabions, or geotextiles) have been employed.

Where to File NOT Form

Send this form to the following address:

Section Supervisor
Inventory & Data Management Section
SWPB, Division of Water
200 Fair Oaks, 4th Floor
Frankfort, KY 40601

Completing the Form

Type or print legibly in the appropriate areas and according to the instructions given for each section. If you have questions about this form, call the Storm Water Contact, Allen Ingram II, at (502) 564-3410.

Section I - Permit Information

Enter the existing KPDES Storm Water General Permit number assigned to the facility or site identified in Section III. If you do not know the permit number, call the Storm Water Contact, Allen Ingram II at (502) 564-3410.

Indicate your reason for submitting this Notice of Termination by checking the appropriate box:

If there has been a change of operator and you are no longer the operator of the facility or site identified in Section III, check the corresponding box.

If all storm water discharges at the facility or site identified in Section III have been terminated, check the corresponding box.

Section II - Facility Operator Information

Give the legal name of the person, firm, public organization, or any other entity that operates the facility or site described in this application. The name of the operator may or may not be the same name as the facility. The operator of the facility is the legal entity which controls the facility's operation. Do not use a colloquial name. Enter the complete address and telephone number of the operator.

Section III - Facility/Site Location Information

Enter the facility's or site's official or legal name and complete address, including city, state and ZIP code. If the facility lacks a street address, indicate the state, the latitude and longitude of the facility using decimal degrees of the approximate center of the site.

If this construction site is part of a larger common plan of development, provide the name of the main contractor, the lot number(s) that you had projects on and for which you are seeking to terminate permit coverage for and the address(es) of those lots.

Section IV - Certification

Federal statutes provide for severe penalties for submitting false information on this application form. Federal regulations require this application to be signed as follows:

For a corporation: by a responsible corporate officer, which means: (i) president, secretary, treasurer, or vice-president of the corporation in charge of a principal business function, or any other person who performs similar policy or decision making functions, or (ii) the manager of one or more manufacturing, production or operating facilities employing more than 250 persons or having gross annual sales or expenditures exceeding \$25 million (in second-quarter 1980 dollars), if authority to sign documents has been assigned or delegated to the manager in accordance with corporate procedures;

For a partnership or sole proprietorship: by a general partner or the proprietor; or

For a municipality, State, Federal, or other public facility: by either a principal executive

Detailed Specifications
May 2009

SECTION 2
TESTING & CONTROL OF MATERIALS

1. Scope

This Section together with such additions, deletions, or modifications, if any, as may appear in any other particular Section of these Detailed Specifications shall govern the furnishing and testing of materials to be used in the work.

Materials of construction, particularly those upon which the strength and durability of the structure or the integrity of a pipeline may depend, shall be subject to inspection and testing to establish conformance with specifications and suitability for uses intended.

2. Cost of Tests and Selection of Testing Agencies

All materials and equipment used in the construction of the project shall be subject to adequate review and testing in accordance with accepted standards. The laboratory or inspection agency will be selected by the Contractor subject to the approval of the Engineer and the Owner. **THE CONTRACTOR SHALL PAY FOR ALL DULY AUTHORIZED LABORATORY INSPECTION AND/OR TESTING SERVICE.**

3. Sources of Supply

The Contractor shall submit a list indicating their proposed sources of supply of all materials including manufactured items and receive the Engineer's approval prior to the placing of orders. The Engineer may require representative samples of any materials prior to approval of the source. The Engineer's approval of the source of any sample shall not be construed to relieve the Contractor of furnishing materials which fully meet all provisions of these Detailed Specifications.

If it is found that sources which have been approved do not furnish uniformly acceptable products, the approval may be withdrawn. The Contractor and his supplier shall afford the Engineer's representative opportunities for inspecting products and materials at any time during their preparation. The Contractor and/or supplier shall furnish shipment thereof, without charge.

These requirements are not intended to stifle or hinder completion but are intended to assure quality and/or performance.

4. Approval of Testing Agencies and Reports

Whenever in these Detailed Specifications review and testing of materials are required, bureaus, laboratories, and/or agencies selected by the Contractor for such inspection and testing service shall be subject to approval by the Engineer.

Documentary evidence, satisfactory to the Engineer, that the material has passed the required inspection and testing must be furnished prior to the incorporation of such materials in the work, and rejected materials must be promptly removed from the premise.

Six (6) copies of all test reports shall be sent to the Engineer's office for checking and distribution.

Test reports shall contain as a minimum (1) the name and location of the supplier's plant, (2) the name of the person gathering the sample, (3) the date of the sampling, and (4) such other like data as may be required by the Engineer.

5. Governing Specifications

It is the intention of the Engineer in the preparation of these General and Detailed Specifications to define properly the kind and quality of materials to be furnished. The standards and tentative standards of the American Society of Testing Materials (ASTM); standards of the American Waterworks Association (AWWA); standards of the American National Standards Institute (ANSI); standards promulgated by the Federal Specification Board (Fed. Spec.); American Association of State Highway and Transportation Officials (AASHTO); the Federal Aviation Agency (FAA); or other such agencies may be referred to in the Detailed Specifications. Where such standards are referred to, said references shall be construed to mean the latest amended and/or revised versions of the said standard or tentative specifications unless specifically stated otherwise. In the selection of samples and the routine testing of materials, the testing laboratory shall follow the standard procedure as outlined by the ASTM, unless otherwise set out.

6. Extent of Inspection and Testing Service

It is intended that materials of construction, particularly those upon which the strength and durability of structures may depend, shall be inspected and tested to establish conformance with specifications and suitability for uses intended. The following is a schedule showing the extent of testing and requirements and methods of reporting. If it is found that this list does not cover all items that will require testing, then such materials shall be tested as directed by the Engineer.

Detailed Specifications
May 2009

7. Cement

Cement shall have been shipped from the mill not more than three (3) months prior to receipt on the work.

- a. Where the total project requirement is less than two hundred (200) barrels (one [1] car) and the concrete is furnished by a ready-mix plant:

Test and certificate of the specification conformance for each shipment shall be furnished from the manufacturer.

- b. Where the total project requirement exceeds two hundred (200) barrels:

Test shall be made on the entire cement requirement by an approved independent laboratory on car samples or bin (sealed) samples as may be required. ASTM Designation C 150-07 shall apply.

8. Fine Aggregate (For Use in Cement Concrete)

Fine aggregate shall consist of natural river sand except that upon request the Engineer may approve manufactured sand. SAND MINED FROM HIGHLAND DEPOSITS WILL NOT BE APPROVED.

Standard tests shall be made in advance of concreting by an approved independent laboratory per ASTM Designation C 33-03, Paragraphs. 2, 3, 4, and 5, and ASTM Designation C 40-04 on each fine aggregate proposed to be used, Alkali reactivity tests as per ASTM Designation C 289-03. Other tests being satisfactory, the aggregate may be used pending results of 28-day strength tests.

9. Coarse Aggregate (For Use in Cement Concrete)

Standard tests shall be made in advance of concreting by an approved laboratory on each grading of each coarse aggregate proposed to be used per ASTM Designation C 33-03, Paragraphs. 7, 8, and 9 and Alkali reactivity tests as per ASTM Designation C 289-03.

10. Advance Tests of Concrete Design Mix(es)

Before commencement of concrete placing and after approval of cement and aggregates, an independent laboratory shall make from a single batch for each proposed mix a set of six (6) standard six (6) inch cylinders per ASTM Designation C 31-08 and test in accordance therewith: Test two (2) cylinders at seven (7) days, two (2) cylinders at fourteen (14) days, and two (2) cylinders at twenty-eight (28) days per ASTM Designation C 39-05e1. Two (2) beam flexure

Detailed Specifications
May 2009

tests as per ASTM Designation C 78-08 shall likewise be made and tested from the design batch if the total requirement exceeds 1,000 cubic yards.

The requirements for tests may be modified at the Engineer's discretion without prejudice to the Engineer later requiring same (if he becomes in doubt about the quality of the concrete) if less than fifty (50) cubic yards are required.

11. Reinforcing Steel

a. A certificate of origin and affidavit will be required for all reinforcing steel. All reinforcing steel shall be manufactured in the United States unless specifically approved by the Engineer.

b. Where less than 25 tons are required:

Field inspection for section, rust, shape, and dimensions plus certified test report for heat number(s).

c. Where 25 or more tons are required:

Inspection and tests by an independent laboratory for conformance with governing specification.

12. Structural Steel

a. Where the requirement is less than twenty (20) tons:

Visual examination at the site and certified copies of mill test on heat number used in fabrication.

b. Where twenty (20) or more tons are required:

Mill and shop observation by an independent laboratory on each heat number to determine compliance with specification designated in these Detailed Specifications.

13. Steel Bar Joists

a. Where less than one hundred (100) joists are required:

There shall be furnished the manufacturer's test data proving the efficiency of the design of the proposed joists for the purpose intended, and in addition, there shall be furnished, certificates that the joists, as furnished, are in accordance with project requirements and with the Standard Specifications for Steel Joists as given in the current handbook "Steel Joist Construction" published by the Steel

Detailed Specifications
May 2009

Joist Institute or other specifications designated in these Detailed Specifications.

- b. Where one hundred (100) or more joists are required:

In addition to requirement (a) for less than one hundred (100) joists, there shall be furnished certificates of the manufacturer of the steel used in fabricating the joists that such steel conforms with the governing specifications.

14. Brick

- a. Where less than 10,000 are required:

Visual examination for shape, color, soundness, cracks, and other imperfections.

- b. Where 10,000 or more are required:

Visual examination as in (a) and absorption and flexure and compression tests as set forth in ASTM Designation C 67-07a or other designated specification by an independent laboratory.

15. Building Stone

- a. Where less than five (5) tons are required:

Visual examination for shape and color.

- b. Where five (5) tons or more are required:

Visual examination as in (a) and tests as set forth in ASTM Designations C 97-02 and C 170-06 or other designated specifications by an independent laboratory.

16. Vitrified Clay Sewer Pipe

- a. Where less than 5,000 feet are required:

Visual examination at the site per ASTM or other designated specification together with certified test reports from the supplier.

- b. Where 5,000 or more feet are required:

Examination and testing as set forth in ASTM or other specification designated in these Detailed Specifications by an independent

laboratory for compliance with governing specification. Each length of pipe shall be inspected and stamped by a regular employee of the approved testing laboratory.

17. Concrete Pipe

- a. Where less than 1,000 feet are required:

Visual examination at the site, as practicable, per ASTM or other designated specification together with certified test reports from the supplier.

- b. Where 1,000 or more feet are required:

Examination and testing, as set forth in ASTM or other designated specification, by an independent laboratory for compliance with governing specification. Each length of pipe shall be inspected and stamped by a regular employee of the approved testing laboratory.

18. Polyvinyl Chloride (PVC) Pressure Pipe

- a. Where less than 5,000 feet are required:

Examination at the site, as practicable, per AWWA, ASTM or other designated specification plus certified test reports from the supplier as performed by the manufacturer.

- b. Where 5,000 or more feet are required:

Examination and testing, as set forth in AWWA, ASTM or other specification designated in the Detailed Specifications by an independent laboratory for compliance with governing specification. Each length of pipe shall be inspected and stamped by a regular employee of the approved testing laboratory.

The following tests shall be performed by an independent laboratory:

Long-Term Pressure Test (Min.)	1,000 hours at 400 psi
Burst Pressure Short Term (Min.)	630 psi
Impact (Min.)	60 ft/lbs at 72°F. 16 ft/lbs at 0°F.
Acetone	20 minutes no flaking

Detailed Specifications
May 2009

Crush (Ring Section)	100% crush no cracking
Vacuum Test (Min.)	22 in/HG for 1 hr.

The results of all tests shall be reported to the Engineer.

19. Polyvinyl Chloride (PVC) Sewer Pipe

- a. Where less than 5,000 feet are required:

Examination at the site, as practicable, per ASTM or other designated specification plus certified test reports from the supplier.

- b. Where 5,000 or more feet are required:

Examination and testing, as set forth in ASTM or other specification designated in these Detailed Specifications by an independent laboratory for compliance with governing specification. Each length of pipe shall be inspected and stamped by a regular employee of the approved testing laboratory.

- c. Testing shall be in accordance with the requirements of ASTM Designation D 2412-02. Minimum "pipe stiffness" (F/Y) at five (5) percent deflection shall be forty-six (46) psi or greater for all pipe sizes. The result of all tests shall be reported to the Engineer.

20. Acrylonitrile - Butadiene - Styrene (ABS) Composite Sewer Pipe

- a. Where less than 5,000 feet are required:

Examination at the site, as practicable, per ASTM or other designated specification plus certified test reports from the supplier.

- b. Where 5,000 or more feet are required:

Examination and testing, as set forth in ASTM or other specification designated in these Detailed Specifications by an independent laboratory for compliance with governing specification. Each length of pipe shall be inspected and stamped by a regular employee of the approved testing laboratory.

- c. Testing shall be performed in accordance with the procedure outlined in ASTM Designation D 2412-02. Minimum "pipe stiffness" (F/Y) at five (5) percent deflection shall be two hundred (200) psi or greater for all pipe sizes. The results of all tests shall be reported to the Engineer.

Detailed Specifications
May 2009

21. Cast Iron and Ductile Iron Pipe and Special Castings

- a. Where less than ten (10) tons are required:

Each piece of pipe shall bear the manufacturer's name or trademark and the date cast. Each piece of pipe should also be certified by the manufacturer to have met the requirements of the governing standard specifications. Also, each piece shall be visually inspected in the field for specification conformance.

- b. Where ten (10) or more tons are required:

Examination and testing at source, as set forth in AWWA, ANSI, ASTM or other designated specification by an independent laboratory for compliance with governing specification. Each length of pipe shall be inspected and stamped by a regular employee of the approved testing laboratory.

If foreign fittings are proposed, a pressure test of each type of fitting in conformance with ANSI/AWWA Standard C153/A21.53-06, Section 5.5 shall be performed in the United States and certified by an approved testing agency. Said certification shall be supplied to the Engineer prior to shipment.

22. Grey Iron Castings

- a. Field Examination: For dimensions, coating, holes hammer test.

- b. Laboratory Tests: Certified test reports by foundry.

If foreign fittings are proposed, a pressure test of each type of fitting in conformance with ANSI/AWWA Standard C153/A21.53-06, Section 5.5 shall be performed in the United States and certified by an approved testing agency. Said certification shall be supplied to the Engineer prior to shipment.

23. Steel Gas Pipe

- a. Where less than 5,000 feet are required:

Visual examination at the site, as practicable, per ASTM or other designated specification together with certified test reports from the supplier.

Detailed Specifications
May 2009

- b. Where 5,000 or more feet are required:

Examination and testing, as set forth in ASTM, APISL or other designated specifications, by an independent laboratory for compliance with governing specification. Each length of pipe shall be inspected and stamped by a regular employee of the approved testing laboratory.

24. Polyethylene Pipe

- a. Where less than 5,000 feet are required:

Examination at the site, as practicable, per ASTM or other designated specification plus certified test reports from the supplier.

- b. Where 5,000 or more feet are required:

Examination and testing, as set forth in ASTM or other specification designated in these Detailed Specifications by an independent laboratory for compliance with governing specification. Each length of pipe shall be inspected and stamped by a regular employee of the approved testing laboratory.

- c. Testing shall be performed in accordance with the procedure outlined in ASTM Designation D 2513-07b.

Detailed Specifications
June 2014

SECTION 3
CONCRETE AND REINFORCING STEEL

1. Scope

This Section covers the materials, mixing, transporting, and placing of all concrete and reinforcing steel including all labor, materials, and equipment.

The provisions of Section 2, Paragraph 2. Cost of Tests and Selection of Testing Agencies applies to this Section of these Detailed Specifications.

Where brand names or manufacturers are used in this Section, it is not intended that the use of products of equal quality and function by other manufacturers be prohibited. Concrete admixtures may be as furnished by Master Builders, Grace Construction Materials, SIKA Chemical Corporation, or approved equal. Concrete forms and accessories may be furnished by Universal Form Company, Dayton Sure-Grip and Shore Company, Heckman Building Products, or equal.

2. Reference Codes and Standards

All work covered by this Section of these Detailed Specifications shall be performed in accordance with the applicable portions of the following American Concrete Institute (ACI) and Concrete Reinforcing Steel Institute Standards (CRSI), as modified in this Section.

<u>ACI 224.3R:</u>	“Joints in Concrete Construction”
<u>ACI 301:</u>	“Specifications for Structural Concrete”
<u>ACI 302.1R:</u>	“Guide for Concrete Floor and Slab Construction”
<u>ACI 305R:</u>	“Hot Weather Concreting”
<u>ACI 306.1:</u>	“Standard Specification for Cold Weather Concreting”
<u>ACI 318:</u>	“Building Code Requirements for Structural Concrete”
<u>ACI 347:</u>	“Guide to Formwork for Concrete”
<u>ACI 350:</u>	“Code Requirements for Environmental Engineering Concrete Structures”
<u>CRSI-MSP:</u>	“Manual of Standard Practice”

The most recent published version (as of the project bid date) of any standard listed in these Detailed Specifications shall apply.

Detailed Specifications
June 2014

3. Class of Concrete

Concrete shall be two (2) classifications as follows:

CLASS "A" - All concrete shall be Class "A" unless otherwise shown on the Plans. ALL reinforced concrete shall be Class "A". Class "A" concrete shall possess the following characteristics and/or proportions of materials.

Minimum Cement Content: 6.0 bags (564 pounds) per cubic yard.

NO FLY ASH WILL BE ALLOWED

Minimum 28-day compressive strength: 4,000 psi average any three (3) cylinders.

Anticipated 28-day compressive strength: 4,000 psi plus.

Slump: Three and one-half (3½) to six (6) inches in walls and columns and piers. Two and one-half (2½) to five (5) inches in slabs, beams, and footings.

Admixtures: A retardant may be required where slow set is desired; where quick set is desired Portland Cement content of 6.2 bags may be required. Air entraining agents optional and subject to Engineer's approval. Additional special admixtures may be specified in subsequent sections of these Detailed Specifications.

CLASS "C" - Concrete used for anchors, kickers, and encasement for pipe lines, for subfoundations and mass footings, and for fill shall be Class "C". No concrete containing reinforcement shall be Class "C". Class "C" concrete shall possess the following characteristics and/or proportions of materials:

Minimum Cement Content: 5.0 bags (470 pounds) per cubic yard.

Minimum 28 day compressive strength 2,500 psi - average of any three (3) cylinders.

NO FLY ASH WILL BE ALLOWED

Slump: Five (5) to eight (8) inches for encasement. Two (2) to four (4) inches in subfoundations and sealing as per Paragraph 10.d. hereinafter.

Admixtures: None required.

Detailed Specifications
June 2014

4. Determination of Strength of Concrete

Compressive strength of concrete shall be determined by use of standard six (6) inch diameter by twelve (12) inch test cylinders in accordance with ASTM Designations C 39 and C 31.

5. Concrete Design Mixes

An independent commercial testing laboratory, approved by the Engineer, shall prepare a design mix for each Class "A" and Class "C" concrete and submit five (5) copies to the Engineer for general approval of the proportions and materials. The design mix shall be accompanied by the quality tests of the materials which are proposed in accordance with Section 2, "Testing and Control of Materials", Paragraphs 5, 8, 9, and 10 of these Detailed Specifications. The sources of supply and the producer of the concrete, if a ready-mix plant, shall be subject to all the requirements of Section 2, "Testing and Control of Materials", and particularly to Paragraph 3. Sources of Supply, thereof. After general approval of the materials and proportions the tests required in Paragraph 10. Advanced Tests and Concrete Design Mix(es) of Section 2 shall be submitted for approval. No concrete may be placed prior to submission and approval of the design mix and of the test results. The cost of obtaining an approvable concrete mix will be paid for by the Contractor.

6. Materials for Concrete

a. Portland Cement *

Portland Cement shall be of American manufacture and shall conform to the "Standard Specifications for Portland Cement" (ASTM Designation C150), of the American Society for Testing and Materials and shall be Type II with an equivalent alkali ($\text{Na}_2\text{O} + 0.658 \text{K}_2\text{O}$) content of less than 0.60 percent and shall have been shipped from the mill not more than three (3) months prior to incorporating into the work unless specifically waived in writing by the Engineer. For job site mixing all cement shall be in sacks. FLY ASH IS NOT AN ACCEPTABLE SUBSTITUTE FOR PORTLAND CEMENT. PREMIXED BAG CONCRETE IS NOT AN ACCEPTABLE SUBSTITUTE FOR PORTLAND CEMENT.

b. Water

Water used in concrete shall be clear and free from objectionable substances such as oil, acid, alkali, vegetable matter, clay, or silt. Water of doubtful quality shall be tested in briquettes which shall reach a strength equal to that of similar briquettes made with water of known satisfactory quality.

c. Admixtures

An air entraining admixture equal to Master Builders MB-VI, Daxes A.E.A. or Aermix, meeting the requirements of ASTM Designation C 260 for Air Entraining Admixtures may be used but is not required. Use of such admixtures is subject to the approval of the Engineer.

The amount of air-entraining admixture to be used will be determined by the percent of air entrained in the concrete. The limits of air will be five (5) percent plus or minus one (1) percent.

The concrete when an approved air entraining agent is used shall have a reduction in weight of not more than three (3) to six (6) pounds per cubic foot as compared with concrete of the same consistency and cement content made without the use of the agent. The specified cement factor shall be maintained by adjusting the quantity of aggregate and water used to the satisfaction of the Engineer. Reduction in the twenty-eight (28) day strength as specified will not be permitted. The use of any other admixture will not be permitted without the written consent of the Engineer as to the admixture to be used and its proportion in the mix.

d. Fine Aggregate

Sand for concrete shall consist of clean, hard, durable uncoated particles, free from lumps of clay, soft or flaky material, loam, and organic matter. In no case shall fine aggregate containing lumps of frozen material be used. Fine aggregate containing appreciable quantities of mica, shale, slate, or other soft grains shall not be used. It shall not contain more than two (2) percent by weight of material which may be removed by the elutriation test. Sands which do not pass the standard colorimetric tests shall not be used unless it can be shown that the failure to pass is caused by particles of lignite or coal. Fine aggregate shall conform to ASTM Designation C 33 with gradation as follows:

<u>Screen</u>	<u>Percent Passing</u>
No. 4	95 -100
No. 16	45 - 95
No. 50	10 - 30
No. 100	2 - 10

Sand shall be tested for potential alkali reactivity as per ASTM Designation C 33 Appendix XI and per C 289.

Detailed Specifications
June 2014

ONLY NATURAL RIVER SAND OR SPECIALLY APPROVED MANUFACTURED SAND SHALL BE USED.

e. Coarse Aggregate

Unless otherwise specified, coarse aggregate may be either crushed limestone, or crushed gravel. Coarse aggregate shall show no evidence of disintegration, and the weighted percentage of loss shall be not more than ten (10) percent by weight when subjected to five (5) alternations of the sodium sulphate test for soundness. It shall be composed of clean, hard, durable, uncoated particles free from deleterious matter. Except for gradation, coarse aggregate shall conform to the requirements of ASTM Designation C 33. The coarse aggregate shall meet the following grading for the various classes of concrete.

For Class "A" Concrete

Passing 1 1/2" square laboratory sieve -	100%
Passing 1" square laboratory sieve -	90 - 100%
Passing 3/4" square laboratory sieve -	50 - 75%
Passing 3/8" square laboratory sieve -	10 - 25%
Passing No. 4 square laboratory sieve -	0 - 5%

For Class "C" Concrete

Passing 2" square laboratory sieve -	100%
Passing 1 1/2" square laboratory sieve -	85 - 100%
Passing 1" square laboratory sieve -	50 - 80%
Passing 3/4" square laboratory sieve -	25 - 40%
Passing 3/8" square laboratory sieve -	5 - 20%
Passing No. 4 square laboratory sieve -	0 - 5%

7. Proportioning of Materials for Concrete

During formulation of the design mix the proportions of aggregate to cement for the grade of concrete specified shall be such as to produce concrete of proper workability. The proportion by dry weight of fine to combined aggregates shall be controlled between limits of thirty (30) to forty-five (45) percent as directed by the Engineer, but the mix shall be so controlled as to use the minimum fine and the maximum coarse aggregate which will give a satisfactory and workable mix.

Measurement of cement, fine and coarse aggregate for all classes of concrete shall be by direct weight upon an approved type of scales. Water shall be accurately measured in gallons by equipment accurate to plus or minus five (5) percent.

Detailed Specifications
June 2014

The weight of cement in unopened sacks as packed by the manufacturer will be considered to be ninety-four (94) pounds per sack. The method of measuring the water shall be accurate and readily adjustable so that the proper ratio of water and cement in each batch may be secured. It is the intention of the Engineer to control rigidly the quantity of water in each mix and to get the densest possible concrete. The Engineer may require calibration of weighing equipment. Equipment for measuring water shall be checked and adjusted daily.

8. Source of Supply of Concrete

a. General

Concrete to be placed in the work may be proportioned and mixed by the Contractor on the site of the work or may be proportioned and mixed in a "Ready-Mix" central plant. Either plant shall be subject to the Engineer's approval of equipment and adequacy prior to the commencement of concrete placement operations. Such approval may be withdrawn by the Engineer if the concrete becomes non-uniform or for other reasons. In the case of such withdrawal of approval the Contractor shall either cause corrections necessary to obtain another approved source.

b. Mixing on Job Site

When small quantities of concrete are required at remote sites or the travel time from a ready-mix plant is deemed excessive or an approvable ready-mix plant is unavailable, the Engineer may approve job site mixing. The Engineer will require what is deemed adequate mixing and quality control equipment.

c. Mixing at a Central Plant

The name and location of the proposed plant and its sources of materials shall be submitted to the Engineer for approval. The Engineer will inspect the plant facilities and proposed mixer trucks and make a determination as to whether they are adequate to meet the quality control required. The Engineer's determination in this case will be FINAL and BINDING. The concrete shall be mixed and handled in accordance with the requirements of ASTM Designation C 94 except as otherwise specified herein. During the period of placing concrete the Engineer shall be afforded free access to the plant for such examinations as the Engineer deem necessary including the stationing of a separate inspector at the plant during batching operations if deemed desirable.

Detailed Specifications
June 2014

(1) Loading Tickets

Loading tickets shall be initialed by the "weight man" (or the inspector) stating (1) the Class of concrete, (2) the name of the project, (3) the time of the batching, and (4) the batch weights of each material including water. When the mixer truck arrives on the job site a copy of the ticket shall be given to the inspector BEFORE the concrete is placed. A CERTIFIED COPY OF THE MATERIALS UTILIZED, THEIR PROPORTIONS, AND THEIR CONFORMANCE TO THE DESIGN MIX PARAMETERS SPECIFIED HEREINBEFORE SHALL BE PROVIDED FOR EACH TRUCK OR LOAD OF CONCRETE DELIVERED TO THE PROJECT SITE. A COPY OF THE REQUIRED CERTIFICATION IS SHOWN BELOW. IF SAID COPY IS NOT PROVIDED, THE LOAD MAY BE REJECTED. Any additional materials added shall be noted.

Each delivery ticket shall have a pre-printed statement signed by a responsible party of the concrete vendor:

I hereby **certify** that this truck contains concrete mixed in accordance with the Design Mix for Class _____ (Class "A" or Class "C") Concrete approved by J. R. Wauford & Company, Consulting Engineers, Inc. Time of truck departure from my ready mix plant _____.

Sworn to this _____ day of _____, 20____.

Name and Title

(2) Transporting

Concrete shall be transported only in approved mixer trucks which will mix the concrete enroute. In extreme hot weather, when approved by the Engineer, the required amount of water may be added upon arrival of the truck at the job site in order to avoid pre-set of the mix enroute. Such approval requires close cooperation of all concerned and will be given only if equipment to accurately measure the water is available and only if strength and slump tests are found to be uniform; approval may be withdrawn for any reason including lack of cooperation. Concrete which reaches the job in a

Detailed Specifications
June 2014

pre-set condition or fails to meet slump requirements will be rejected and shall be removed from the job site. No retempering with water or any other admixture will be allowed except in special emergencies and under the conditions set in Paragraph 9. Alteration of Concrete Slump (Retempering).

9. Alteration of Concrete Slump (Retempering)

ANY ALTERATION OF CONCRETE IS TOTALLY THE CONTRACTOR'S RESPONSIBILITY.

The concrete shall be mixed only in such quantities as required for immediate use, and shall be used while fresh and before initial set has taken place. The addition of water or some other plasticizer (sometimes called retempering) to a ready-mix truck at the job-site or such addition at any place more than ten (10) minutes after the original water charge has been added and mixing commenced is strictly prohibited except as provided herein. Any concrete which arrives on the job in which initial set has begun shall be wasted and not used in the work.

At the request of the Contractor, the Resident Observer may permit water and Portland cement to be added at the rate of twelve (12) gallons of water per sack of cement. If Portland Cement is not available without too great a time delay the Contractor may add up to one (1) gallon of water per cubic yard at its own risk.

If concrete arrives on the job too wet the slump may be altered by adding Portland cement and thoroughly mixing.

Any concrete which is altered shall have double the specified number of cylinders taken after said alteration and no work shall be added onto the pour in question until the quality is assured.

10. Placing of Concrete

a. General

All concrete shall be placed in daylight or daylight conditions approved by the Engineer and ONLY AFTER the Engineer's representative has been notified and has inspected and approved the placement of reinforcing steel and the general condition of form work.

All water and accumulated debris shall be removed from forms and observation holes shall be left in wall forms near the bottom for such purpose. For footings and on-grade slabs water shall be diverted or otherwise removed. For walls, beams, columns, and supported slabs the forms shall be wetted with water so as to tighten joints. Runways, where

Detailed Specifications
June 2014

used, shall be independently supported so as to prevent disturbance of the forms.

CONCRETE WITHIN ANY UNIT OF WORK BETWEEN CONSTRUCTION JOINTS SHALL BE PLACED CONTINUOUSLY TO PREVENT "COLD JOINTS". New concrete shall be placed AGAINST each succeeding batch so as to build up a continuous monolithic "pour".

b. Cold Weather Placing of Concrete

No concrete shall be placed when the air temperature in a shaded area away from artificial heat is 40°F and falling. Concrete may be mixed and placed under the conditions set forth herein if the air temperature in the shade is 35°F and rising provided the Contractor makes provisions for heating to maintain 45°F and there is a U. S. Weather Bureau forecast for 45°F or above. When the air in the shade falls below 50°F the mixing water shall be heated (Maximum 140°F) so that the temperature of the concrete when deposited is between 60°F and 75°F. Several thermometers shall be maintained by the Contractor at the site of the work and placed as directed by the Engineer.

The Contractor shall supply such heating equipment as vented stoves and/or salamanders as are necessary to keep the temperature of the air surrounding the concrete from falling below 45°F until test specimens indicate the concrete has attained a compressive strength of 2,500 psi or greater or for a period of five (5) days. The Engineer may require additional heating units to be placed in operation if in the Engineer's opinion the concrete might be endangered by an additional drop in air temperature. When the required heating period has expired the concrete shall not be allowed to cool at a rate faster than 1°F per hour.

c. Hot Weather Placing of Concrete

When the temperature of the air exceeds 90°F or the average temperature for the period of placement exceeds 85°F or is predicted by a U.S. Weather Bureau forecast to exceed said limits special precautions are required. The temperature of the concrete shall not be allowed to exceed 90°F. Ice shall be substituted for mixing water prior to the addition of the other materials to mixer in order to maintain temperature. The ice shall be accurately weighed (8.34 pounds = 1 gallon) prior to its being placed in the mixer and the remaining mixing water reduced correspondingly. The temperature shall not be reduced below 65°F.

The maximum time allowed in the mixer by ASTM Designation C 94 (either three hundred [300] revolutions or one and one-half [1½] hours whichever occurs first) shall be considered the acceptable maximum at air

temperatures between +45°F and +70°F. The following maximum allowables shall apply at various temperatures:

<u>Average Air Temperature</u>	<u>Maximum Time or Revolutions</u>
45°F - 70°F	1½ hours or 300
70°F - 80°F	1 hour or 200
80°F - 90°F	45 min. or 150
90°F - 100°F	30 min. or 100
100°F	No placing allowed

Extreme care shall prevail in the pouring of thin slabs and other thin sections. All forms, reinforcing steel, and/or subgrades shall be wet with cool water as shall all mixers, chutes, *etc.* immediately prior to concrete placement. No puddles of water shall be present at the time of placement.

d. Placing Concrete in Foundations

Whenever possible all foundation excavations shall be pumped dry and concrete deposited in the open. If it is not possible to proceed in this manner, a seal of concrete of sufficient thickness to resist any possible uplift shall be deposited under water in accordance with special directions of the Engineer. After the seal has set sufficiently, the foundation shall be pumped out; and the balance of the concrete placed in the dry.

e. Placing Concrete in Forms

Concrete shall be conveyed as soon as possible after mixing to the place in which it is to be deposited. The method and manner of placing shall be such as to avoid the possibility of segregation or separation of the aggregates or the displacement of the reinforcement. The concrete shall be deposited so as to bring the construction up level and during the process, it shall be vibrated, rammed, spaded, or agitated by satisfactory tools so as to produce a compact concrete of maximum density with all spaces or voids filled and presenting a smooth, unbroken surface, free from coarse aggregate to exposed honeycomb spaces when the forms are removed.

f. Pumping or Chuting Concrete

If concrete is conveyed by pumps or chutes, the equipment shall be of such size and design as to insure a practically continuous flow. The slope of the chute or the design of the conveyance tubes shall be such as to allow concrete of a satisfactorily dry consistency to flow without separation of the ingredients. The chute or tube shall be thoroughly flushed with water

Detailed Specifications
June 2014

before and after each run, discharging outside of the forms. Should stoppage occur in the chute or tube during concreting and the use of water be required to clean it, the water and all material removed from the chute or tube shall be wasted outside the forms. If, in the opinion of the Engineer, the arrangements for placement are such as to preclude the securing of watertight, smooth, dense concrete in any portion of the work, other and satisfactory means of transporting concrete shall be employed by the Contractor.

g. Vibrating Concrete

All concrete shall be vibrated in the forms as it is placed with mechanical internal vibrators maintaining 5,000 impulses per minute and approved by the Engineer. At least one (1) extra vibrator in operating condition shall be maintained at the job site in case of emergency.

11. Curing of Concrete

a. General

All concrete shall be protected from too rapid drying or curing by the covering of surfaces with burlap, curing compound as per ASTM Designation C 309, Type I, or other suitable means immediately after finishing, concrete shall be kept moist for a sufficient period of time to insure satisfactory curing as directed by the Engineer, normally three (3) consecutive days.

b. Cold Weather Curing

If concrete is placed in cold weather the Contractor shall provide the necessary heat to insure that the temperature of the air immediately surrounding the fresh concrete does not drop below 45°F at any time, at any place, and that the concrete is uniformly kept warm until the concrete has obtained a compressive strength of 2,500 psi or greater for at least five (5) days. The variations in temperature shall not exceed 10°F and no hot air shall be allowed to blow directly upon the fresh or curing concrete. The surfaces shall be protected from frost by covering with suitable blankets at any time the temperature is forecast to drop below 50°F.

c. Hot Weather Curing

During the curing of concrete in hot weather all surfaces shall be kept covered with burlap sacks or polyethylene and kept moist for a period of five (5) days after placing, after which the protective covering shall be allowed to gradually dry out.

Detailed Specifications
June 2014

The most extreme care shall be exercised to maintain a moist surface on slabs during the first twenty-four (24) hours after placement, and the Engineer, during periods of low humidity compounded by surface winds, may require continual wetting of the surface for a period of twenty-four (24) hours. After the first twenty-four (24) hours the surface shall be wet down when work is begun in the mornings and also at intervals during the day if required by the Engineer and left wet in the evenings.

12. Joints in Concrete

a. General

The placement of concrete shall be as shown on the Plans and/or approved "concrete placing plans" between construction joints. In general a unit shall not exceed thirty (30) feet in each direction nor more than nine hundred (900) square feet although the Engineer may approved larger pours when same are submitted in five (5) copies under the same procedure outlined for shop drawings and are to be considered as a shop drawing.

Vertical construction joints shall be provided at intervals of thirty feet (30') or less from corners and between construction joints on walls enclosing water holding basins above grade and dry spaces below grade. Horizontal construction joints shall be provided at intervals of thirty feet (30') or less in walls enclosing dry spaces below grade. Structural slabs on grade reinforced with deformed bars may be placed in pours of any dimension desired between construction joints.

Where a construction joint is made, laitance, all weak concrete, and foreign matter shall be removed and the concrete roughened.

On all joints except "expansion joints" the reinforcing shall be set to extend into subsequent sections of construction so as to make the work a monolith. JOINTS SHALL NOT BE MADE EXCEPT AS THE ENGINEER MAY INDICATE, APPROVE, OR DIRECT TO PRESERVE THE STRENGTH, FACILITY OF PLACEMENT, OR WATERTIGHTNESS OF THE STRUCTURES. In general, the locations of the joints are shown on the Plans; but these may be changed if the Contractor requests and the Engineer approves. A period of at least forty-eight (48) hours shall elapse between the placement of adjacent concrete units or pours.

b. Watertight Expansion Joints

An expansion joint is defined as a joint specially constructed to allow movement as shown on the Plans. Expansion joints shall be constructed in accordance with the details shown on the Plans utilizing a steel plate, a

Detailed Specifications
June 2014

steel slide recess clip, Hornflex Primer expansion joint filler or equal, and Thiokol LP-32 sealant or equal, and shall be watertight in water holding structures or dry wells. The steel plate shall be uncoated steel bar stock meeting the requirements of ASTM Designation A 36. The slide recess clip shall be fabricated twenty (20) gauge steel sheet with a hot-dipped galvanized coating. The expansion joint filler shall be the asphalt type conforming to the requirements of ASTM Designation D 994 and shall be Type 6 as manufactured by W. R. Meadows, Inc. or equal. The exterior sealant shall be a two (2) part polysulfide rubber joint sealant conforming to the requirements of ASTM Designation C 920 for Class 25 sealants without primer and shall be T-2282 as manufactured by Morton Polymer Systems or equal. The filler shall be applied so as to prevent "tracking" if accidentally stepped on.

c. Joints in Footings and Walls

Construction joints in footings and walls shall be located across areas of low shearing stress and shall be provided with keyways. Keyway details shall be as shown on the Plans or in special cases as directed. Waterstops shall be provided where shown on the Plans.

Expansion joints shall be located where shown on the Plans using the details of construction shown on the Plans.

d. Joints in Slabs and Beams

Construction joints shall be located near the middle of spans of slabs, beams, or girders; unless a beam intersects a girder at this point, in which case the joints in the girders shall be off-set a distance equal to twice the width of the beam. In this case, provision shall be made for shear by use of inclined reinforcement. Keyways shall be provided as shown on the Plans.

Expansion joints shall be located where shown on the Plans using the details of construction shown on the Plans.

e. Waterstops and Watertightness

Dry wells and structures housing equipment shall be watertight with no visible leaks and no accumulation of water. Any visible leaks shall be repaired to the satisfaction of the Engineer. Waterstops consisting of eight (8) inch wide by one-eighth (1/8) inch thick steel plates made continuous and watertight by continuous weld of the joints and shall be placed as shown on the Plans. Certain waterstops may be shown on the Plans as copper for special reasons. Keyways with eight (8) inch wide, sixteen (16)

ounce copper waterstops for construction joints shall be used where such joints are shown and shall be soldered watertight.

Certain waterstops may be shown on the Plans as PVC or other material for special reasons.

f. Mastic Joints

Where joint sealer or mastic joint is noted on the Plans, the joints shall be sealed with the material designated on the Plans. All materials shall be installed in strict accordance with the manufacturer's instructions, and under the supervision of a qualified representative of the manufacturer. All surfaces and slots in concrete shall be provided as required by the manufacturer of the joint material.

g. Control Joints in Non-Reinforced, Non-Structural Slabs on Grade

Control joints in slabs on-grade which are reinforced with welded wire fabric only shall be saw cut and shall be a minimum of one-eighth inch (1/8") wide by one-fourth (1/4) the section in depth. Sawing of control joints shall be completed between twelve (12) and twenty-four (24) hours after finishing of the concrete surfaces. Timing of saw cutting shall be such that the slabs have sufficiently cured where no dislodging of aggregate occurs during the sawing operations.

The spacing of control joints and/or construction joints in slabs on grade shall generally not exceed fifteen feet (15').

Control joints in sidewalks shall be formed by tooling a groove downward from the surface with a one-fourth inch (1/4") edging tool. Spacing of control joints shall be equal to width of sidewalk.

h. Isolation Joints

Isolation joints to separate slabs from column footings, intersecting walls, *etc.* shall be provided. Isolation joint material shall be one-half inch (1/2") thick by the full depth of the slab, unless otherwise noted on the Plans, and shall meet the requirements of ASTM Designation D 1994 for bituminous type performed joint filler.

Isolation joints separating concrete sidewalks from structures, concrete curbs, *etc.* shall be one-half inch (1/2") thick by the full depth of the sidewalk.

Detailed Specifications
June 2014

I. Joint Sealant

Where joint sealant is noted on the Plans and the joint sealant material is not designated, the joint sealant shall conform to the requirements of ASTM Designation C 1516 for cold application type concrete joint sealer.

13. Non-Shrink Grout

Non-shrink grout shall be used where called for on the Plans or required to insure watertightness. The proportions of the non-shrink grout mix shall be:

15 pounds Embecco or equal
100 pounds Portland Cement
100 pounds sand
150 pounds pea gravel (may be omitted)

14. Forms for Concrete Work

a. General

If required by the Engineer, forming plans shall be submitted by the Contractor and approved by the Engineer before the forms are on the work. The Contractor may submit a plan or schedule for forming for the Engineer's consideration. The Engineer's approval of the Contractor's method of forming will be for the benefit of the Contractor and will be based on the acceptability of the finished work; in no case will the Engineer pass on or be responsible for the structural adequacy of the Contractor's forms, false-work, or other construction procedures.

Forms shall be substantial and sufficiently tight to prevent leakage of mortar. They shall be properly placed or tied together so as to maintain position and shape and insure safety to workmen and passersby. Temporary openings shall be provided where necessary to facilitate cleaning and observation immediately before depositing concrete. CONCRETE SHALL NOT BE PLACED IN ANY FORM UNTIL THE FORM AND THE RESTEEL IS OBSERVED BY THE ENGINEER. Such Engineer comment or approval does not apply to the structural integrity of the framework which is the total responsibility of the Contractor. The Contractor shall be completely responsible for the strength and adequacy of the form work and shall save the Owner and/or Engineer harmless from any claims arising therefrom for any reason.

b. False Work

All false work shall be solely the Contractor's responsibility as to strength, line, and grade, etc.; but the Engineer may disapprove work which is

unworkmanlike, or in the opinion of the Engineer, will not yield the finished product required.

c. Material for Forms

The forms for the outside face of all exposed surfaces shall be of not less than one and one-half (1½) inch tongue and grooved lumber dressed on both edges and on the face next to the concrete or three-fourths (¾) inch plywood panels unless otherwise shown on the Plans or specifically permitted by the Engineer. Forms for all other concrete work may be constructed with one (1) inch by six (6) inch tongue and grooved sheathing or one (1) inch ship-lap. Where shown on the drawings or required in these Detailed Specifications, or by the Engineer, forms for all exposed walls - both inside and outside shall be constructed of three-fourths (¾) inch plywood which, in all cases, must be approved by the Engineer.

Moldings and the ornamentation shown on the Plans shall be formed with wood or metal molds. The width of all boards used for such work shall be approved by the Engineer.

d. Unlined Forms

Unlined forms may be used on unexposed surfaces of walls, slabs, columns, and beams unless otherwise specified herein or as shown on the Plans. Form boards shall not be re-used in contact with exposed surfaces unless they are thoroughly cleaned and oiled and approved by the Engineer.

e. Lined Forms

Where specified herein or where shown on the Plans, plywood panel or lined forms will be used for certain portions of concrete masonry structures. Where lined forms are used, the lining shall be of fiber board or plywood which must, in all cases, be approved by the Engineer. All lining materials shall be used in as wide pieces as a single width of fiber board. The lining material shall be nailed to the backing beginning at the center of the board and working toward the edges to prevent buckling. Cigar box nails or similar nails with flat heads shall be used to attach lining material to forms. The edges of the linings shall be butted tight together, and joints between the sheets shall be filled with a compound of litharge or Rutland Patching Plaster, or approved equal. Lining material may be re-used if it is satisfactorily cleaned and approved by the Engineer.

The smooth side of the lining materials shall be placed next to the concrete surface where smooth surfaces are specified; where granular surfaces are

Detailed Specifications
June 2014

indicated or specified, the rough surfaces of the lining materials shall be placed next to the concrete.

f. Steel Forms

The use of steel forms may be used when approved in writing by the Engineer. Ties used with steel forms shall be of the type designed to remain permanently in place and conform to the requirements for form ties hereinafter. Steel forms, if used, shall be placed under the direction of a trained and competent representative of the supplier and the Contractor shall be totally responsible for their structural integrity.

g. Form Ties

Approved form ties shall be used for all wall construction. The ties shall be of the type that snap back in the wall, or permit removal of the tie ends. Ties shall be adjustable to permit tightening of forms, and of such type that will require a minimum amount of pointing with no metal closer than one-half (1/2) inch from face of wall. No ties will be permitted that require more than one and one-half (1½) inch for pointing. REMOVAL OR PULL-OUT TYPE TIES WILL NOT BE PERMITTED UNDER ANY CIRCUMSTANCES. Form ties with three-fourths (3/4) inch wood concrete snap ties shall be as manufactured by the Universal Form Company of Chicago, Illinois, or approved equal.

h. Form Release Agents

All forms that are not restricted by the form manufacturer from application of a form release agent shall receive a volatile organic compound (VOC) compliant, non-staining, reactive, architectural application form release agent. The form release agent shall be applied in accordance with the manufacturer's instructions. Form release agents shall be Reacts as manufactured by CONSPEC Marketing and Manufacturing Company, Inc. or equal.

i. Removal of Forms

Forms shall not be removed until the concrete has attained a strength sufficient to support itself and the superimposed loads. Under normal curing conditions (average temperature 50°F or above) the forms may be removed after following minimum time has elapsed.

Floor slabs, beams, and girders	-	10 days
---------------------------------	---	---------

Columns, pedestals, and sections less than 12 inches thick	-	4 days
---	---	--------

Detailed Specifications
June 2014

Wall lifts (12 inches thick) under 10 feet	-	2 days (48 hrs. min.)
Wall lifts (12 inches thick) over 10 feet	-	3 days (72 hrs. min.)

In cold weather forms shall not be removed from any work when the danger exists of freezing the concrete or otherwise damaging the surface. Whenever a question exists as to removal of forms, the forms shall not be removed until a standard cylinder cured on the site in a manner similar to the work represented has attained a compressive strength of 3,000 psi.

The use of the foregoing table shall in no way relieve the Contractor of its responsibility for the safety and integrity of the structure.

15. Floor Drains, Sleeves, and Inserts

The Contractor shall be responsible for placing all sleeves, floor drains (which shall be placed one (1) inch low and the floor sloped thereto), wall castings, step nosing, and other inserts in the concrete walls and floors in their proper positions. If for any reason said sleeves, wall castings, and/or other inserts are not delivered prior to pouring, the Contractor shall box out for same in a manner acceptable to the Engineer. It shall then become the responsibility of the Contractor to place same and make a watertight closure of the openings in a manner satisfactory to the Engineer.

16. Slabs on Grade

a. Subgrade Preparation

Subgrade shall be prepared and constructed in accordance with "Guide for Concrete Floor and Slab Construction", ACI 302.1R and as hereinafter stipulated.

The subgrade shall be compacted in the presence of the Engineer immediately prior to the fine grading operation. All soft or unstable material detected during the final compacting shall be cut out and the area reworked to provide the specified density.

After final compacting, a six inch (6") crushed stone base shall be constructed as required to obtain the specified slab thickness within a tolerance of plus or minus one-fourth inch (1/4"). All ruts and depressions shall be filled to eliminate any abrupt changes in slab thickness.

Detailed Specifications
June 2014

A SIX (6) MIL POLYETHYLENE VAPOR BARRIER MEETING THE REQUIREMENTS OF ASTM DESIGNATION D 2103 SHALL BE PLACED OVER THE PREPARED CRUSHED STONE BASE PRIOR TO PLACING CONCRETE FOR THE SLAB.

b. Slab Placement

Materials and construction requirements relating to slabs on grade shall be in accordance with provisions outlined in this Section of the Specifications, in accordance with the "Guide for Concrete Floor and Slab Construction", ACI 302.1R and as hereinafter stipulated.

Slabs on grade which are not shown to pitch to drain shall be constructed to a uniform plane at the elevation shown on the Plans. Tolerance of dead-level slabs shall be plus or minus one-fourth inch ($\pm 1/4"$) in ten feet (10') (F_{F22} and F_{L22}). Slabs at floor drains shall be finished with a four foot (4') diameter dish with center of dish one inch (1") below floor level.

Reinforcing steel shall be cut at isolation joints and expansion joints. Wire mesh reinforcement and bar reinforcement shall be placed as shown on the Plans.

Slabs shall be constructed in a strip pattern. The width of each strip shall coincide with the distance between column lines. Construction joints shall occur at the column lines in buildings.

Concrete shall be discharged as close to its final position as possible. Concrete shall be screeded with hollow metal straightedges, vibrating screeds or roller screeds. After initial screeding, low spots shall be filled with additional concrete placed by shovel and these areas shall be rescreeded. Screeding must be completed before any excess water or bleeding water is present on the surface of the concrete.

Immediately after screeding and before any excess moisture or bleeding water is present on the surface of the concrete, surfaces shall be bull floated with wood floats to eliminate ridges and fill in voids left by straight-edging operations.

Concrete shall be floated after it has stiffened to the point where foot pressure can be sustained with a maximum of one-fourth inch (1/4") indentation. Floating shall be performed, utilizing power floats or trowelling machines fitted with float shoes. Surfaces inaccessible to power driven machines shall be hand floated, utilizing wood, magnesium or aluminum hand floats.

Detailed Specifications
June 2014

c. Curing

(1) Interior Floor Slabs

Interior floor slabs shall be cured with a membrane curing compound designed to cure, seal, harden, and dustproof. This compound shall be applied within one-half (½) hour after completion of finishing operations and/or immediately after disappearance of the "sheen" of surface moisture. Slab surfaces shall be uniformly coated at the rate recommended by the manufacturer. Application of material shall be by means of a roller or spray gun. If the floor slab is constructed prior to completion of the building envelope, floor surfaces shall be covered with curing sheets meeting the requirements of ASTM Designation C 171. Sheets shall be securely anchored and maintained in place for a minimum of seven (7) days.

(2) Exterior Slabs and Water Holding Basin Floor Slabs

Exterior floor slabs, slabs on grade not requiring special coatings, and floor slabs of water holding basins shall be cured with a membrane curing compound designed to cure and seal. The curing and sealing compound shall be a hydrocarbon, resin-based compound meeting the requirements of ASTM Designation C 309, Type 1, 1D, Class A and Class B. This compound shall be applied within one-half (½) hour after completion of finishing operations in accordance with the manufacturer's instructions. Slab surfaces shall be uniformly coated at the rate recommended by the manufacturer. Curing and sealing compound shall be RX Cure manufactured by CONSPEC Marketing and Manufacturing Company, Inc. or equal.

As an alternative to use of membrane curing compound, the exterior slab may be completely covered with burlap and continuously soaked for ninety-six (96) hours after placing with a potable water sprinkler system.

17. Aluminum Safety Treads

The Contractor shall furnish and install on the leading edge of stairs, steps and landings nosings which shall be eight (8) inches less than the width of the surface to which said the nosing is attached (four [4] inches each side). The nosings shall be three (3) inches wide of the non-skid type equal to Wooster Products Type 101 alumogrip abrasive cast aluminum. Attachment shall be with concealed anchors on new work (for renovations use stainless steel screws). The

Detailed Specifications
June 2014

installations shall be such that the top of nosing is flush with the top of the slab to which it is attached.

18. Concrete Finish

a. Floor Slabs

The concrete floors of all structures shall be finished monolithically with an allowable variation of one-eighth (1/8) inch in ten (10) feet transversely and longitudinally.

Concrete floor slabs on grade shall be placed over a well tamped and compacted subgrade. Form all recesses for thickened slabs, as shown on the Plans and thoroughly compact stone. Lay vapor barrier of six (6) mil (0.006 in.) thickness polyethylene over fill. Vapor barrier shall follow the contour of the thickness of the slab.

All floor drains shall be set one (1) inch lower than grade and the slab pitched thereto.

Slabs to receive quarry tile shall be finished by tamping the concrete with special tools to force the aggregate away from the surface; then screeded with straight edges and floated to produce a reasonably true and uniform surface.

b. Walls, Beams, Ceilings and Columns

(1) General

All concrete walls, ceilings, and beams shall be pointed; those which are to be exposed permanently to view, including the interior of basins to a point twelve (12) inches below the water line, shall be pointed and rubbed. If the surface is to be painted it shall be left smooth and all loose concrete rubbed away by use of a rough burlap sack or other effective method; if the surface is not to be painted it shall be rubbed as hereinafter specified. Foundation walls shall be rubbed to a point one (1) foot below grade on the outside. All projecting fins shall be removed from the concrete and holes left by form ties shall be pointed up.

(2) Pointing

After the specified curing times have elapsed, forms and form ties shall be removed and all depressions or imperfections inspected by the Engineer. After the Engineer has approved the general integrity

of the work, all imperfections shall be wetted and repaired with non-shrink sand-cement mortar.

(3) Rubbing

After pointing has set, all surfaces requiring rubbing shall be kept wetted with water with a brush and rubbed with a No. 20 carborundum stone. The rubbing shall be continued sufficiently long to remove all marks and projections, producing a smooth, even surface without marked irregularities. The final rubbing shall be done with a No. 40 carborundum stone and continued until the entire surface is of smooth texture. After the rubbing has been finished, all excess particles shall be removed by brushing the surface with burlap. The finished surface shall be uniform in color and otherwise satisfactory to the Engineer.

(4) Coating

IF APPROVED by the Engineer in lieu of rubbing concrete, all structural cast-in-place concrete foundations, walls, beams, columns, roofs, ceiling and equipment foundations exposed to view and not identified or depicted on the accompanying Plans to receive any other finish or treatment, including the interior of all water holding structures to an elevation twelve inches (12") below the minimum normal water level and exposed exterior concrete walls to an elevation twelve inches (12") below finished grade, shall be coated as described hereinafter.

The coating shall be Thoroseal Plaster Mix or equal combined with water and Thoroseal Acryl 60R or equal, both manufactured by Harris Speciality chemicals, Inc., in the proportions recommended by the product manufacturer for a trowel finish coating approximately one-eighth inch (1/8") to one-fourth inch (1/4") thick. The coating shall be applied according to the manufacturer's printed instructions including a "key coat" cured five (5) to seven (7) days followed by a final coat applied with a steel trowel and finished with a sponge float. All concrete coating described in this Paragraph shall be applied with a trowel finish, except that the coating to the underside of overhanging walkways may be applied with a brush finish. Application by spraying will not be allowed. All products used shall be those manufactured by Harris Specialty Chemicals, Inc., or approved equal.

The color shall be selected by the Owner.

Detailed Specifications
June 2014

c. Exterior Slabs

All walks, platforms, and exterior floors or slabwork shall have a broomed finish. After screeding to the required grade while the concrete is still green, but has hardened sufficiently to bear the finisher's weight the surface shall be floated with a wood float to a true and even plane with no coarse aggregate visible. The slab shall then be evenly broomed with all strokes parallel to leave a workmanlike skid resistant finish.

d. Chamfer

All exposed edges shall be chamfered three-fourths (3/4) inch unless otherwise noted.

19. Watertightness

a. General

The Contractor is required to make watertight concrete in all structures holding water or solutions or dry wells or basements. All cracks and imperfections developing at any point in the work shall be thoroughly repaired in a manner satisfactory to the Engineer. When the concrete work has attained sufficient strength, the Contractor shall fill each basin or tank, or each compartment, with water, and shall repair any imperfections which cause the water level to fall more than one-half inch (1/2") in twenty-four (24) hours. All noticeable leaks in any portion of the work shall be repaired in any case, even if the preceding requirements as to watertightness are satisfied. THE CONTRACTOR MAY CONDUCT THIS WATERTIGHTNESS TEST EITHER BEFORE OR AFTER BACKFILLING EXTERIOR WALLS.

It is expected that with the proper precautions, a dense watertight concrete will be obtained. If concrete which passes the above requirements for watertightness has not been obtained, the Contractor shall, under the direction of the Engineer, furnish all materials and do all work necessary to produce watertight concrete structures.

All treatment of concrete necessary to fulfill these requirements for watertightness shall be done at the Contractor's own expense.

b. Dampproofing

The outer surface of all exterior concrete walls enclosing dry spaces (e.g. pits or structures housing equipment, valves or instruments) that is to be covered by backfill or by brick or decorative block shall be coated with an emulsion type asphalt dampproofing prior to backfilling or laying of brick.

Detailed Specifications
June 2014

The dampproofing shall conform to ASTM Designation D 1227, Type 4 for brush-on application to concrete surfaces. Concrete structures containing water or wastewater do not require dampproofing.

Surfaces to receive dampproofing shall be clean and dry before application of dampproofing. Surfaces shall be primed in accordance with the manufacturer's recommendation. The dampproofing shall be applied uniformly at a rate of not less than thirty (30) pounds per one hundred (100) square feet.

Dampproofing shall be protected from damage until brick or decorative block is laid or backfill is placed. Concrete walls exposed to view after completion of construction shall not be waterproofed.

20. Defective Concrete

Concrete shall be so placed, compacted, finished and cured so as to form a dense, compact, impervious artificial stone with smooth exposed faces. Any part of the work found to be honeycombed, porous, or otherwise defective in the opinion of the Engineer shall be removed or replaced in whole or in part at the expense of the Contractor.

21. Testing of Concrete

In general, Section 2 of these Detailed Specifications, entitled "Testing and Control of Materials" governs all testing.

The following tests and/or samples shall be taken in the field as work progresses:

a. Standard Slump Tests

Field slump tests shall be made by the Contractor, using an accurately made sheet iron test cone, in accordance with the provision of ASTM Designation C 143. At least one (1) slump test shall be made for each truck; the Engineer may require additional tests if he deems it necessary to insure the desired consistency of the concrete.

b. Concrete Compression Samples

(1) During the progress of the work and for each different mix of concrete, test cylinders shall be made from each day's pour with a minimum of one (1) for each twenty-five (25) cubic yards or a maximum of one (1) from each batch or readymix truck load. The maximum requirement will be imposed only when the Engineer deems necessary due to wide fluctuations in the concrete quality. A minimum of three (3) cylinders will be required for each day's pour

Detailed Specifications
June 2014

if the concrete is used in structures or otherwise in a load carrying capacity. Sidewalks, manholes, etc., may require only one (1) cylinder if less than twenty-five (25) cubic yards per day is placed, and the quality remains sufficiently high in the opinion of the Engineer.

Each cylinder shall be numbered and logged so as to adequately identify the location of the representative concrete in the structure.

The following "break" schedule for cylinders from the same pour will be used:

Where only one (1) cylinder is made	-	28 days
Where two (2) cylinders are made	-	one at 7 days
	-	one at 28 days
Where three (3) cylinders are made	-	one at 7 days
	-	one at 14 days
	-	one at 28 days
Where four (4) cylinders are made	-	one at 7 days
	-	one at 14 days
	-	one at 28 days
	-	one reserved
Where over four (4) cylinders are made	-	Same as four plus reserve or as directed.

ASTM Designation C 31 shall govern with curing as required. The testing shall be done per ASTM Designation C 39.

22. Reinforcing Steel

a. General

Bar reinforcement and wire mesh reinforcement shall be furnished and tested in accordance with Section 2, "Testing and Control of Materials". CERTIFIED MILL TEST REPORTS SHALL ALSO BE FURNISHED TOGETHER WITH AN AFFIDAVIT INDICATING THE ORIGIN.

Detailed Specifications
June 2014

b. Bar Reinforcement

Reinforcing steel shall conform to the requirements of ASTM Designation A 615 new billet steel, Grade 60, with deformations conforming with ASTM Designation A 615. An affidavit showing the heat numbers and origin shall be furnished.

All bars shall be lapped a minimum of thirty (30) diameters at splices unless a greater lap is shown on the Plans.

All detailing, fabrication, and erection of reinforcing bars, unless otherwise noted, shall be in accordance with the ACI "Manual of Standard Practice for Details and Detailing of Concrete Reinforcement" (ACI 315).

The Contractor shall furnish the Engineer with five (5) copies of shop drawings of reinforcing bars, and schedules showing all bends and special bars. These shop drawings and schedules must have the approval of the Engineer before shipment is made. The bars shall bear a designation on the drawings and in the schedule and shall be tagged with metal tags for identification. The Engineer's representative shall be afforded free access to the fabricating shops.

c. Wire Mesh Reinforcement

Wire mesh reinforcement shall conform to the requirements of ASTM Designation A 185.

d. Openings

Openings twelve (12) inches and larger through concrete walls and slabs shall have a minimum of four (4) extra diagonal bars in each face of the wall or slab of the same size as the largest bar in the wall or slab. The length of extra diagonal bars at openings shall engage a minimum of forty (40) bar diameters each side of the opening unless space requires full bond to be developed by means of hooks.

e. Minimum Reinforcing Steel

If through an omission Class "A" concrete walls, slabs, and other concrete work are shown on the Plans to have no reinforcing, a minimum area of steel reinforcing equal to 0.0018 times the cross-sectional area of the concrete work shall be provided.

Detailed Specifications
June 2014

f. Storage and Protection

Steel reinforcement, either bars or mesh, shall be new stock free from rust scale and shall be stored above the surface of the ground upon platforms, skids, or other supports and protected from the weather. When placed in the work it shall be free from rust, dirt, scale, paint, oil, or other foreign matter which may reduce or destroy bond. A thin coating of red rust resulting from short exposures will not be considered objectionable when bars are placed in the work; but any bars having rust scale or a thick rust coat shall be thoroughly cleaned to the satisfaction of the Engineer, or shall be rejected and removed from the premises if ordered by the Engineer.

g. Placing and Fastening of Reinforcement and Inspection Thereof

Steel reinforcement shall be placed in the exact position as shown on the Plans and held securely in place during the placing of the concrete. All reinforcement shall be wired together at intersections or as directed by the Engineer. Sheet metal or welded wire bar spacers shall be used for bars in all steps, walls, and beams. Hychairs, or approved equal, shall be provided for the support of reinforcement of slabs and flat surfaces. When the reinforcement is placed in the work, it shall have a clean, fresh surface, free from dirt, scaly rust, mill scale, paint, oil or other foreign substances.

BEFORE ANY CONCRETE IS PLACED, THE ENGINEER SHALL HAVE EXAMINED THE PLACING OF THE STEEL REINFORCEMENT AND GIVEN PERMISSION TO DEPOSIT THE CONCRETE. CONCRETE PLACED IN VIOLATION OF THIS PROVISION MAY BE REJECTED AND THEREUPON SHALL BE REMOVED.

23. Concrete Repair Material

Where the repair of existing Portland cement concrete is noted on the accompanying Plans, the following procedures and materials shall be utilized to perform the repair.

All surfaces to be repaired shall be prepared as necessary to make them clean and structurally sound. The surface shall be cleaned by chipping, acid-etching, sandblasting and/or shot-blast cleaning methods to remove all dust, grease, paint, sealers and other foreign materials from the Portland cement concrete surface to be repaired. If acid-etching is used, the surface to be repaired shall be neutralized using a caustic solution and brushed prior to performing the repair. The Portland cement concrete surface to be repaired shall be kept damp for thirty (30) minutes prior to beginning the repair work but standing water shall not be allowed on the surface to be repaired.

Detailed Specifications
June 2014

The repair material shall be a two (2) component acrylic polymer modified concrete repair material. The material shall be mixed and applied in strict accordance with the manufacturer's written instructions. The concrete repair material shall be Patchcrete® manufactured by Lyons Manufacturing, Inc. or equal.

Detailed Specifications
2021 – June 2015

SECTION 4

WATER LINE AND APPURTENANCES

1. Scope of Work

The work covered under this section of these Detailed Specifications consists of furnishing all labor, materials, equipment and services necessary for the construction of Water System Improvements, Contract 15-01 – 16-inch North Water Transmission Line – Phase I as generally outlined hereinafter and as specifically described in these Detailed Specifications. The work will be delivered under one contract with the approximate quantities and descriptions as follows:

CONTRACT 15-01

16-INCH NORTH WATER TRANSMISSION LINE – PHASE I

- Three Lump Sum connections to existing 8-inch (1), 10-inch (1), and 12-inch (1) Water Lines
- 185 L.F. of 24-inch Steel Casing Pipe bored under Western Kentucky Parkway
- 195 L.F. of 16-inch RJDIP installed in 24-inch Steel Casing Pipe
- 3,450 L.F. of 16-inch Class 250 DIP
- 12,226 L.F. of 16-inch C-905 PVC
- 3 Each Fire Hydrant Assemblies
- 6 Each 16-inch Butterfly Valve Assemblies
- 11 Each 4-inch Air Release Valve Assemblies
- BCBC Tank Control Valve and Structure

2. Location of Lines

The Water Line shall be laid to such lines and grades as shown on the Plans and to insure appropriate depths of cover and that fire hydrants have sufficient depth and function properly. The final location as constructed may be varied by the Contractor(s) with the approval of the Engineer provided (1) the proposed location is approved by the Owner and any agency or legal entity having jurisdiction, and (2) the effect lessens the project cost. The final location in any event may be varied by necessity due to construction conditions at the direction of the Engineer due to requirements of the Owner, the property owners, or other agency or legal entity having jurisdiction.

Detailed Specifications
2021 – June 2015

3. Pipeline Materials for Water Lines

a. General

The pipe for underground water lines shall be DR 21 C-905 polyvinyl chloride (PVC) water pipe with standard gasketed joints unless otherwise noted. In certain locations, ductile iron pipe shall be installed where shown on the Plans or directed by the Engineer at the pressure class indicated hereinafter.

b. Ductile Iron Pipe

(1) Materials, Manufacture and Joints

Ductile iron pipe shall be centrifugally cast, manufactured and tested in accordance with the ANSI/AWWA Standard C150/A21.50-02 for Ductile Cast Iron, Grade 60-42-10. The nominal wall thickness for each pipe size and Pressure Class shall be as follows:

<u>Size</u>	<u>Pressure Class</u>	<u>Wall Thickness (Inches)</u>
8-inch	350	0.25
10-inch	350	0.26
12-inch	350	0.28
16-inch	250	0.30

The pipe shall be manufactured and tested in accordance with the requirements of ANSI Specification A21.51.

Pipe shall be push-on type joint incorporating a single molded rubber ring gasket unless otherwise indicated and shall be furnished tar coated outside and the manufacturer's standard cement lined inside to comply with ANSI Specification A21.4.

(2) Joint Lengths and Joint Deflection

Standard joint length shall be 20 feet; however, shorter lengths may be used in order to achieve the alignment or grade required. The maximum allowable joint deflection for DIP pipe is 5 degrees (21 inches per 20-foot length, regardless of the layout shown on the Plans); in order to achieve the alignment or grade, shorter lengths or extra fittings will be required. The maximum joint deflection will be strictly enforced. Bending of the pipe will not be allowed.

Detailed Specifications
2021 – June 2015

(3) Ductile Iron Fittings

All fittings for ductile iron pipe shall be Class 350 mechanical joint single gasket ductile iron conforming to ANSI/AWWA C153/A21.53, and shall meet the current requirements for the manufacturer's standards. Fittings shown on the Plans are intended to convey the general configuration, but the Contractor shall furnish all fittings required.

Each fitting shall be certified by the manufacturer to have been tested and to have met the requirements of the governing standard specifications.

All fittings shall use thrust restraint devices in lieu of the standard glands. Thrust restraint devices shall be Series 1100 Megalug as manufactured by EBAA Iron, Inc. unless otherwise noted. Series 3800 Megalug as manufactured by EBAA Iron, Inc. shall be used to connect to existing ductile iron pipe with new polyvinyl chloride pipe as noted.

All fittings shall be furnished tar coated outside and the manufacturer's standard cement lined inside to comply with ANSI Specification A21.4.

(3) Pipe Bedding and Backfill

See Paragraph 8.c. of this Section of these Detailed Specifications.

(4) Testing

See Paragraph 21 of Section 2 of these Detailed Specifications.

(5) Markings

Each length of pipe and fittings shall have the following information plainly marked on the pipe's exterior:

- a. Nominal Size
- b. Class
- c. Manufacturer
- d. Independent Testing Laboratory Stamp
- e. Quality Control Code
- f. NSF (National Sanitation Foundation) Standard 61 Stamp Seal of Approval

Detailed Specifications
2021 – June 2015

(6) Restrained Joint Pipe

Ductile iron pipe with restrained joints shall be Class 350 and conform to the latest revisions of ANSI Specification A21.10, A21.11 and A21.51. The pipe shall be installed where shown on the Plans or directed by the Engineer and shall utilize American Fast Grip gaskets or approved equal.

c. Polyvinyl Chloride (PVC) Pressure Pipe

(1) Materials, Manufacturer and Joints

Polyvinyl Chloride (PVC) Pressure Pipe shall conform to ANSI/AWWA Standard C-905 and shall be installed in accordance with ANSI/AWWA C-605 as amended or extended in these Specifications. The pipe shall be CI outside diameter in accordance with Table 2 of ANSI/AWWA C-905. PVC pipe shall be green in color.

The following classes of pipe and pressure ratings are called for:

<u>Outside Diameter (in.)</u>	<u>Dimension Ration (DR)</u>	<u>Min. Wall Thickness</u>	<u>Pressure Class (psi)</u>
17.40	21	0.829	200

(2) Fittings

Fittings shall be ductile iron as specified herein.

(3) Joint Requirements

Joints shall be push-on type compatible with ductile iron fittings. Joints and gaskets shall meet the requirements of Section 4.5 and the applicable provisions of Section 5 of ANSI/AWWA C905.

(4) Joint Lengths and Joint Deflection

Standard joint length shall be 20 feet; however, shorter lengths may be used in order to achieve the alignment or grade required. The maximum allowable joint deflection for PVC pipe is 1 degree (4 inches per 20-foot length, regardless of the layout shown on the Plans); in order to achieve the alignment or grade, shorter lengths or extra fittings will be required. The maximum joint deflection will be strictly enforced. Bending of the pipe will not be allowed.

Detailed Specifications
2021 – June 2015

(5) Pipe Locators

A No. 14 copper tracer wire and a locator tape announcing "water line" shall be located above the pipeline approximately 12 inches below finished grade.

(6) Pipe Storage, Bedding, Laying and Backfill

The governing specification is ANSI/AWWA C-605 as extended in Paragraph 11 of this Section and by the details shown on the Plans.

(7) Markings

Each length of pipe shall have the following markings as called for in Section 6.1 of ANSI/AWWA C-905.

- a. Nominal diameter and O.D. base
- b. PVC
- c. Dimension Ratio
- d. AWWA pressure rating
- e. AWWA C905
- f. Manufacturer's name or trademark and production record code
- g. Stamp of independent testing laboratory indicating inspection and approval

(8) Affidavit of Compliance

The manufacturer shall give an affidavit of compliance with the cited standards as well as proof of inspection by an independent testing laboratory.

4. On-Site Inspection of Pipeline Materials

Before allowing any pipe or fittings to be paid for as "stored materials" the Engineer shall be afforded the opportunity to inspect and mark it on-site.

The inspection shall consist of a visual inspection for obvious cracks, improper markings or other defects and a dimensional inspection. The Contractor(s) shall furnish templates or other means of ascertaining the compliance of the pipe to the dimensional allowances in the governing specifications.

Rejected pipe or fittings will be painted with an orange or red "X" and the date. Such rejected materials shall be immediately segregated from acceptable pipe and shall be removed from the project within 14 days.

Detailed Specifications
2021 – June 2015

5. Lines and Grades

Water lines shall be graded to service lines or fire hydrants so as to prevent accumulation of air. Where extra depth is shown on the Plans or grading of the pipe is required to prevent accumulation of air, elevation shots shall be taken to ensure that the profile is followed and the intent is accomplished.

6. Excavation for Pipeline Trenches and Appurtenances

a. General

Excavation on this project, whether earth or rock, is not a separate pay item but is to be merged into the price of the pipeline shown in the BID FORM. The excavation shall be carried to the depths indicated on the Plans and/or directed by the Engineer to permit proper bedding of the pipe.

The Contractor(s), at his own expense, shall provide adequate facilities for promptly removing water from all excavations.

Unless otherwise indicated trenches shall be excavated in open cut to the depths shown on the Plans. Trenches shall be of the minimum width shown on a Detail on the Plans. Unless specifically authorized by the Engineer, trenches shall not be excavated wider than 1 foot 6 inches plus the outside diameter of the pipe, at the level of the crown of the pipe.

Unless specifically directed otherwise by the Engineer or where required to uncover or determine the presence of underground obstructions, not more than three hundred (300) feet of trench shall be opened ahead of the pipe laying, and not more than two hundred (200) feet of open ditch shall be left behind the pipe laying. Before laying the pipe, the Contractor(s) shall open the trench far enough ahead to reveal obstructions that may necessitate changing the line or grade of the pipeline.

All barricades and other such signs and signals as may be necessary to warn the public of the dangers in connection with open trenches, excavations and other obstructions shall be provided by and at the expense of the Contractor(s).

The trench shall be straight and uniform so as to permit laying pipe to the proper lines and grades.

When so required, by the Owner through the Engineer, one-half of the street crossings and road crossings shall be excavated, then temporary bridges consisting of ½-inch steel plate shall be placed over the side excavated for the convenience of the traveling public; then the remainder of the excavation shall be carried out. All backfilled ditches shall be

Detailed Specifications
2021 – June 2015

maintained in such a manner that they offer minimal hazard to the passage of traffic. The convenience of the traveling public and the property owners abutting the improvements shall be taken into consideration. All public or private drives shall be promptly backfilled or bridged.

In excavation for masonry and concrete structures including manholes, the required width shall be such as to permit forms to be constructed in the proper manner and to permit proper backfilling upon completion of the structures. Depth of excavation for footings shall be as shown on the Plans and/or as directed by the Engineer to obtain sufficient bearing.

All excavated material not needed for backfilling purposes shall be disposed of in a manner satisfactory to the Owner.

In all areas along highways or roadways where the pipeline is being laid in the pavement or in the right-of-way of the road, excavation during each day shall be limited to the footage of pipe that can be laid and the trench be backfilled so that minimal ditch is left open overnight in such areas.

All excavation shall be accomplished in accordance with applicable safety laws and regulations; the Engineer, as previously stated, does not assume responsibility of any degree or sort for acts of the Contractor(s).

b. Unstable Trench Bottom Material or Undercutting

If wet, mucky and/or unstable or unsuitable material is encountered in a trench bottom, the Engineer may require additional excavation to insure a firm foundation for the pipe. The quantity of undercutting will be determined by the actual ditch width or a maximum of the diameter of the pipe plus 1.5 feet, multiplied by the difference between the depth of ditch ordered and 6 inches below the invert elevation of the pipe. In such cases, the trench bottom shall be brought back up to proper grade with bedding material as provided herein. Crushed stone (KDH No. 9) refill required shall be paid for at the unit price per cubic yard set forth in the BID FORM, including all excavation, if such excavation and refill is directed by the Engineer. If the Contractor(s) has caused the extra work due to failure to properly dewater the ditch, no payment will be made.

The Engineer shall determine when it is necessary to use such material and the Contractor(s) shall be responsible for calling such unstable trench bottom conditions to the attention of the Engineer.

c. Depths of Cover

The excavation for water lines shall be carried to the depths indicated on the Plans and/or directed by the Engineer to permit proper bedding,

Detailed Specifications
2021 – June 2015

release of air from the pipe and to prevent "air-locking" or the trapping of air in high points. Unless otherwise shown, trenches shall be opened to a depth so that the top of the pipe shall not be less than thirty six (36) inches below the surface of the ground when laid through wooded areas, fields, and other such areas outside the pavement or traveled surface of highways and roadways. The minimum depth of cover shall not be less than thirty six (36) inches for pipelines laid in the shoulder or traveled surface of any highway and/or roadway. Extra depth of cover is required as shown on the profiles on the Plans. Should the Contractor(s) fail to follow the Plan Profile, the Engineer may require removal and replacement of the pipeline on the planned grade or installation of Fire Hydrant Assemblies, all without additional compensation. The minimum cover over valve operating nuts is 12-inches.

All depths of cover are measured to the top of the pipe by placing a straight edge resting on the surface of the original ground and measuring down to the pipe away from the bell.

d. Excavation on Easements

Excavation of pipeline trenches on easements shall be performed in such a manner that the grounds shall be restored to as near their original condition as possible considering the work performed. The grass cover of the ditches or excavations shall be the same type as the original undisturbed cover.

Before any excavation is begun or before drilling and blasting, a minimum of nine (9) inches of the top soil or the original cover shall be removed and stockpiled in a manner so as not to contaminate the topsoil with other fill or excavated material. Should the depth of excavation require a trench wider than specified in Subparagraph A. above, a minimum of nine (9) inches of topsoil or original cover shall be removed from the additional area and stockpiled as described hereinbefore.

Excavated materials suitable for backfill shall be placed at a distance far enough from the ditch to allow excavated rock to be placed next to the open trench, however stockpiling outside the easement shall be done only with the property owner's written permission. **THE CONTRACTOR'S ATTENTION IS CALLED TO SECTION 1, PARAGRAPH 10 OF THESE DETAILED SPECIFICATIONS.**

e. Removal of Water

The Contractor(s) shall at all times during construction provide and maintain means and devices with which to promptly dispose of all water entering the excavations or other parts of the work and shall keep said

Detailed Specifications
2021 – June 2015

excavations dry until the structures to be built therein are completed. No concrete shall be placed in water nor shall water be allowed to rise over structures if there is danger of flotation or of setting up unequal pressures in the concrete, until the concrete has set at least 24 hours and any danger of flotation has been removed.

The Contractor(s) shall dispose of water from the work in a suitable manner without damage to adjacent property or water lines. No water shall be drained into work built or under construction.

During the laying of lines and until the water line has been bedded in place with at least 2 feet of backfill over the pipe, the Contractor(s) shall keep the groundwater table below the bottom of the trench.

No lines will be permitted to be laid except in a dry trench. Running water shall be completely blocked off by dewatering and/or sheathing. The trench must be dry and clean to assure that the hub and spigot of the pipe are perfectly dry before a joint is made.

All removal and handling of water required to maintain dry trenches or other excavations for the construction of lines or other structures in the dry trench shall be at the expense of the Contractor(s).

7. Rock Excavation

ROCK EXCAVATION IS NOT A SEPARATE PAY ITEM.

8. Pipe Laying and Bedding for Water Lines

a. General

The trench shall be excavated to the required depth and width; bell holes and/or jointing holes shall be dug in advance of pipe laying.

The bed of each piece of pipe shall be carefully prepared so that each individual piece of pipe shall have a uniform bearing. Pipes shall be laid in a straight line and grade without kinks or sags, and shall be laid in a workmanlike manner. Bell holes and/or jointing holes shall be large enough so that the bell or hub will clear the ground and leave ample room for making joint and inspection of joints.

Before each piece of pipe is lowered into the trench, it shall be thoroughly swabbed out to insure its being clean. Each piece of pipe shall be lowered separately unless special permission is given otherwise by the Engineer.

Detailed Specifications
2021 – June 2015

Care shall be taken to prevent injury to the pipe coating both inside and out. No piece of pipe or fitting which is known to be defective shall be laid or placed in the lines.

If any defective pipe or fitting shall be discovered after the pipeline is laid, they shall be removed and replaced with a satisfactory pipe or fitting without additional charge. In case a length of pipe is cut to fit a line, it shall be so cut as to leave a smooth end at right angles to the longitudinal axis of the pipe as required by AWWA Standard C600.

All angles or bends in the pipelines, either vertical or horizontal, shall be satisfactorily braced or anchored against the tendency of movement with joint harness, concrete or equal anchors to the satisfaction of the Engineer and as shown on the Plans.

Open ends of unfinished pipelines shall be securely plugged or closed at the end of each day's work or when the line is left temporarily at any other time. The maximum horizontal or vertical deflection for laying pipe shall be one-half the allowable manufacturer's deflection.

b. Unstable Trench Bottom Material or Undercutting

If wet, mucky and/or unstable or unsuitable material is encountered in the trench bottom, it shall be excavated and backfilled as specified in Paragraph 6.b. Unstable Trench Bottom Material or Undercutting, hereinbefore.

The Engineer shall determine when it is necessary to use such material and the Contractor shall be responsible for calling such unstable trench bottom conditions to the attention of the Engineer.

c. Ductile Iron Pipe

Ductile iron pipe shall be laid on a soil foundation by placing select backfill material on the excavated trench bottom to a depth of not less than four (4) inches as per AWWA Standard C150 Laying Condition 3. Bell holes shall be provided to insure that the pipe is uniformly supported over its entire length. Any unyielding material such as rock within the pipe foundation shall be removed and the foundation shall be brought up to grade as specified in Subparagraph a. of this Paragraph. No rock larger than two (2) inches shall be permitted within twelve (12) inches of the pipe.

9. Unauthorized Excavation and Over-Breakage

Whenever the excavation is carried beyond or below the lines and grades given by the Engineer, the Contractor, at his own expense, shall refill such excavated

Detailed Specifications
2021 – June 2015

space with such material and in such a manner as will insure stability of the structure or line involved, including the use of crushed stone or Class "C" concrete.

Over-breakage is that portion of any material displaced or loosened beyond the finished work as planned or authorized by the Engineer, including slides. All over-breakage shall be removed by the Contractor and disposed of as directed. PAYMENT WILL NOT BE MADE FOR REMOVAL AND DISPOSAL OF OVER-BREAKAGE.

10. Crushed Stone for Pipe Bedding in Rock

When rock is encountered, the trench shall be excavated to a depth at least 6 inches below the invert of the pipe and refilled with the bedding material to a sufficient depth to provide a firm bed for the bottom quadrant of the pipe. If a rock trencher is used for excavation, the native materials may be used for bedding if they meet the maximum grading specification for Kentucky Department of Highways size No. 9 crushed stone. Crushed stone or select native materials shall be utilized to the depths as shown on the Plans. The price of such material shall NOT be a separate pay item.

11. Backfilling Pipeline Trenches

a. General

In the backfilling of the trench above the pipe or pipe envelope, material reasonably free from rock and acceptable to the Engineer shall be used; the backfill material shall be carefully and solidly tamped around the pipe up to the point where the pipe is thoroughly covered with at least one (1) foot of material. Walking or working on the completed pipeline, except as may be necessary in tamping or backfilling, shall not be permitted until the trench has been backfilled to a height of at least one (1) foot above the top of the pipe. The filling of the trench shall be carried on simultaneously on both sides of the pipe in such a manner that the completed pipeline will not be disturbed and injurious side pressures do not occur.

In filling the remainder of the trench, the backfill material may be shoveled into the trench without compacting, and heaped over whenever, in the opinion of the Engineer, this method of backfilling may be used without inconvenience to the public. Where street paving or shoulders are to be replaced, the Contractor will be required to tamp or puddle all backfill as described hereinafter.

In areas where the line is laid in the right-of-way but outside paved areas of a State Highway or when required by the Engineer, the backfill material shall be of select material of the same type as the existing natural material

or fill in which the trench is dug. When so required by the Owner of the roadway, the backfill shall be placed in loose layers not exceeding six (6) inches and firmly tamped into place by tampers or rammers. With the approval of the State Department of Transportation, the Engineer may also require puddling wherein, in his opinion, it is also necessary for proper compaction.

BACKFILL MATERIAL IN PAVED STREETS SHALL BE CRUSHED STONE AS SPECIFIED IN PARAGRAPH 12. PIPELINE TRENCHES WITHIN EXISTING ROADWAYS HEREINAFTER.

Whenever, in the opinion of the Engineer, it is necessary, he may require the Contractor to use a combination of any or all of the above-outlined methods for proper compaction of the backfill in the trenches.

Before final acceptance, the Contractor will be required to level off all trenches where backfill material has been piled up, or to bring the trench up to the level of the surrounding street, roadway, or terrain. The Contractor will be required to remove from the streets, roadways, and private property all excess earth or other materials.

b. Backfilling Operations Conducted on Easements

Backfilling of trenches or excavations on easements shall be performed in such a manner that the private property owner's facilities and grounds shall be restored to as near as possible their original condition immediately after pipe laying.

After the pipe bedding, pipe, and backfill along the sides of the pipe and over the pipe (if required) as specified hereinbefore has been placed, the excavated rock next to the ditch shall be placed in the ditch. Excavated rock shall not be placed any closer than 18 inches from the finished grade and any excess rock shall be removed by the Contractor and disposed of as directed.

The residue of the stockpiled bedding material shall be cleaned up and placed into the trench, leaving no bedding stone scattered over the area. The previously excavated materials suitable for backfill shall be placed into the ditch only upon clean-up and backfill of the bedding material. The top portion of the trench or excavation shall be filled using the stockpiled top soil. The ditch shall be left high to allow for settling unless in the opinion of the Engineer this method of backfilling will cause inconvenience to the private property owner. Seeding or sodding shall proceed immediately following backfill.

Detailed Specifications
2021 – June 2015

If the backfilling operation is performed during extremely dry weather, the Contractor should leave some stockpiled topsoil to use later as additional fill after settlement has occurred.

THE CONTRACTOR WILL BE HELD RESPONSIBLE FOR THE CONDITION OF GRASS COVER AND THE CONDITION OF THE GROUND SURFACE AT THE TIME OF FINAL INSPECTION UNLESS THE PRIVATE OWNER HAS PLOWED OR EXCAVATED THE GROUND.

12. Pipeline Trenches Within Existing Roadways

Where excavation is within the traveled portion of State Highways, the Ohio County roads, all native earth and rock shall be removed and hauled away and disposed of by the Contractor(s) at his own expense. The resulting backfill material shall be compacted KYTC NO. 57 crushed stone as shown on the Plans.

13. Inspection of Lines - During Construction

The Contractor shall notify the Engineer when pipe will be received on the job so that arrangements may be made for inspecting and unloading and stringing, as well as inspecting the pipe proper and examining for the stamp of the independent laboratory.

BEFORE THE CONTRACTOR BACKFILLS ANY OF THE LINES, THEY SHALL BE FIRST INSPECTED BY THE ENGINEER, AND THE ENGINEER SHALL GIVE THE CONTRACTOR PERMISSION TO PROCEED WITH THE BACKFILLING. If any joints, pipes, or other workmanship or materials are found to be defective, they shall be removed and replaced by the Contractor without any extra compensation.

14. Testing of Water Lines

Testing of lines shall comply with the provisions of AWWA C600 as summarized below, or similar approved procedures which will insure equal or better results. Leakage shall not exceed the following values at the test pressure shown on the following table:

Allowable Leakage / 1000 Feet

<u>Pipe Size</u>	<u>Test Pressure (psi)</u>	<u>Allowable Leakage (gallons/hour)</u>
16-inch	150	1.32

The Contractor shall furnish all gauges, meters, pumps, and other equipment required and shall maintain said equipment in condition for accurate testing as

Detailed Specifications
2021 – June 2015

determined by the Engineer. Where practicable, pipelines shall be tested in lengths between line valves or plugs of no more than three thousand (3,000) feet. Where leaks are visible at exposed joints and/or evident on the surface when joints are covered, the pipe shall be rejoined and leakage minimized regardless of total leakage as shown by test.

Duration of test shall be not less than two (2) hours where joints are exposed and not less than eight (8) hours where joints are covered. The Contractor shall start the eight hour test at 8:00 a.m. local time and stop the test at 4:00 p.m. local time. If requested, the Contractor shall supply a cover, latch, and locking mechanism for the test apparatus to accept a padlock supplied by the Owner. Lines which fail to meet the leakage requirements shall be repaired and retested until test requirements are met. All pipe, fittings, and other materials found to be defective under test shall be removed and replaced at the Contractor's expense.

Pipelines shall be held under normal operating pressures for at least three (3) days before testing.

15. Connections/Disconnections

The Contractor shall make the required connections to existing water lines as shown on the Plans and as specified in these Detailed Specifications. The work of connecting new lines to existing lines is the responsibility of the Contractor and IS NOT a separate pay item unless indicated otherwise in the BID FORM; it being the intent of these Detailed Specifications to provide a complete operable facility.

16. Fire Hydrants

Fire hydrants shall be dry-barrel type in accordance with the requirements of AWWA Standard C 502 suitable for 200 psi.

The hydrants shall have 6-inch mechanical joint inlets, 5 1/4-inch valve opening, 6 1/2-inch inside diameter riser barrel, minimum 42 inches of bury (depth as required at each location), standard operating nuts opening left (counter-clockwise) and safety "breakable" flanges located a minimum of 2 1/2 inches and a maximum of 3 1/2 inches above the ground line. The hydrant shall be equipped with two (2) 2 1/2-inch hoses nozzles and one (1) 4 1/2-inch pump nozzle.

Exterior surfaces of hydrants shall be painted after installation with one (1) coat of primer and two (2) coats of red Hydrant Enamel.

Fire hydrants shall be equal to Mueller Super Centurion 200 Series. FIRE HYDRANT BARREL EXTENSIONS SHALL BE FURNISHED WHERE REQUIRED.

Detailed Specifications
2021 – June 2015

17. Disinfection of Water Lines

The new water lines shall not be placed in service - either temporarily or permanently - until they have been thoroughly disinfected in accordance with the following requirements and the requirements of the Kentucky Division of Water.

Disinfection shall be accomplished by filling the new and/or repaired portions of the system with water having a chlorine content of at least 50 parts per million and at the end of a 24-hour contact time a residual of at least 25 parts per million shall remain. At the end of the 24-hour contact period, all the sterilized surfaces and areas shall be disposed of according to 401 KAR 5:031 and 8:020, which state that the allowable in stream concentration of chlorine are 10 ug/l, which is equal to 0.01 mg/l. The Contractor shall submit in writing to the Ohio County Water District (OCWD) the method he proposes for dechlorinating. Recommended chemicals, as given in AWWA C651, are sulfur dioxide, sodium bisulfate, sodium sulfite, and sodium thiosulfate.

For tie-ins to an existing system such as tapping sleeves and valves where keeping the main out of service would restrict service to existing customers, disinfection shall, at the OCWD's discretion, consist of thoroughly cleaning the new part with a solution containing not less than 200 mg/l (ppm) chlorine.

After initial disinfection and flushing, the OCWD will collect water samples for bacteriological testing. A core zone, which includes up to the first 1/2 mile, shall be established. Two samples shall be taken from the core zone. Additionally, one sample taken from each mile of new distribution main shall be submitted to the Cabinet. A new or routine replacement main shall not be placed in service until negative laboratory results are obtained on the bacteriological analyses. Sample bottles shall be clearly identified as "special" construction tests. If any of the samples are found positive or contain confluent growth, the Contractor shall repeat the disinfection procedure until the required numbers of negative samples are obtained.

18. Pipeline Crossings of Roadways

a. General

Where shown on the Plans or directed by the Engineer, crossings of roadways shall be either open cut or bored.

b. Bored Crossings of Western Kentucky Parkway

(1) General

Where shown on the Plans or directed by the Engineer, the Contractor shall bore crossings of roadways with a steel casing pipe

as specified in Subparagraph (2) hereinafter. The pipe shall be jacked through a bored hole. Where boring is required under a highway, the holes shall be bored at least four (4) feet below the surface with no disturbance to the surface.

The Contractor must be fully equipped and experienced in the installation of pipelines by boring or tunneling methods. The Contractor shall be fully responsible for the successful operation without interruption of traffic and shall be held responsible for any settlement which occurs as a result of his work.

IT SHALL BE THE RESPONSIBILITY OF THE CONTRACTOR TO DETERMINE THE NUMBER OF CASING SPACERS AND SIZE REQUIRED (BORING) OR THE NUMBER OF ANCHORS AND SIZE REQUIRED TO PREVENT FLOTATION OR NEGATIVE GRADE OF THE CARRIER PIPE.

(2) Steel Casing Pipe

Black steel casing pipe shall be manufactured and tested in accordance with ASTM Specification A 139 or A 53, Grade B, 35,000 psi yield strength, and shall meet the American Railway Engineering Association (AREA) Specification for Metal Pipe and Arches, Chapter 1, Part 5.

Steel casing pipe where shown shall be as follows:

<u>Diameter Carrier in Inches</u>	<u>Diameter Casing in Inches</u>	<u>Minimum Wall Thickness of Casing in Inches</u>
16	24	0.500

19. Gate Valves and Boxes

Valves 12-inches in diameter and smaller shall be gate valves. Gate valves shall conform to AWWA Standard C509 as extended and/or modified herein. All gate valves shall be of the resilient seat type, iron body, non-rising stem, fully bronze mounted, suitable for water working pressure of 200 psi. Valves shall be of a standard manufacture and of the highest quality both as to materials and workmanship. An affidavit of compliance is required. Bolting materials shall be cadmium plated. The stem sealing shall be by an O-ring.

Gate valves shall be furnished with mechanical joint end-connections, unless otherwise shown on the Plans or specified herein. The end-connections furnished shall be suitable for connection to the pipe furnished.

Detailed Specifications
2021 – June 2015

All gate valves shall have the name or monogram of the manufacturer, the year the valve casting was made, the size of the valve, and the working water pressure cast on the body of the valve. Each valve shall be epoxy coated and touched up in the field as required.

Gate valves shall be provided with a 2-inch square operating nut and shall open by turning to the left (counter-clockwise). Gate valves shall be Mueller or an approved equal.

Valve boxes shall be cast iron, THREE (3) PIECE, screw type with drop cover marked "Water". They shall be set vertically and properly adjusted so that the cover shall be in the same plane as the finished surface of the ground or street. For ease of location and identification, a 2'-0" square by 6-inch thick concrete pad with a cast aluminum plaque with raised letters identifying the valve shall be imbedded therein as shown on the Plans.

20. Tapping Sleeves and Valves

Tapping sleeves with mechanical joint ends and flanged connection for valve together with a gate valve conforming to Paragraph 19. Gate Valves and Boxes of this Section of these Detailed Specifications shall be provided where required. Tapping sleeves and valves shall have a pressure rating corresponding to the pressure zone in which they are located. The Contractor shall verify in the field the type of existing pipe that the tapping sleeve will be used in connection with. The valve shall be supplied with a THREE (3) PIECE valve box and operating nut. Tapping sleeves shall be as manufactured by Mueller or approved equal.

21. Butterfly Valves and Boxes

Valves 16-inch in diameter shall be butterfly valves. Butterfly valves for pipe line service shall be suitable for 200 psi working pressure, shall be designed for underground service and shall meet the requirements of AWWA Standard C506 as modified hereinafter. Butterfly valves shall be Dezurik or approved equal. Valves may be either of the "short" or "long" laying length type where this meets service conditions.

Butterfly valves shall be furnished with mechanical joint end connections unless flanged connections are requested by the Contractor. The end connections shall be suitable for connections to cast or ductile iron pipe. "Slip-on" joints will not be allowed.

Valve operators shall consist of a geared 2-inch square nut and shall conform to the latest revision of AWWA Standard C504 and shall be designed to hold the valve in any intermediate position between fully open and fully closed without creeping or fluttering. The gear box shall be fully sealed and grease packed. Valve operators shall be capable of resisting without damage an input of at least

Detailed Specifications
2021 – June 2015

300 foot pounds. Valves shall open by turning counter-clockwise. The valve shall be supplied with a THREE (3) PIECE cast iron valve box and a drop cover marked "Water".

22. Air Valves and Pits

a. General

Air Valves in Concrete Pits shall be installed at the high points in the pipelines as shown on the Plans. This item includes the miscellaneous metals, small valves and piping within the pit as shown on the Plans. Air Valves shall be Vent-O-Mat Model No. 100RBX1631 suitable for the working pressure and test pressure as shown on the Plans.

All Air Valves shall be double orifice with anti-shock orifice mechanism. The bottom flange shall be ANSI B16.1 Class 125 suitable for mounting to the 4-inch ductile iron piping as shown on the Plans.

b. Precast Concrete Pits (Manholes) Frames and Covers

The Air Valves shall be housed in precast concrete manholes with cast iron frame and cover entrances as shown on the Plans. The precast sections shall conform to the requirements of ASTM C478.

Manhole frames and covers shall be grey iron ASTM A-48 and set in a bed of mastic and bolted to the pre-cast concrete ring as shown on the Plans. The cover shall have four vent holes, shall have at least a 24-inch diameter opening and shall have "WATER" cast into the cover. The surface between the cover and the frame shall fit smoothly without rocking.

The manhole steps shall be cast into the concrete manhole rings as shown on the Plans and shall consist of copolymer polypropylene plastic with no-skid grooves conforming to ASTM D4101 with a 1/2-inch Grade 60 reinforcing bar through its center. Each step shall be 12 inches (minimum) in width and capable of carrying a load of 1,000 pounds applied at the center of the step at a point 6 inches from the wall. Steps shall be staggered.

c. Piping and Valve

The piping system in air valve pits shall be suitable for the test pressure and the psi working pressure shown on the Plans.

For air valves 4-inch and larger, piping shall be Special Thickness Class 53 ductile iron pipe with ANSI B16.1 Class 125# flanges. Gate valves shall

Detailed Specifications
2021 – June 2015

have 125# flanges and shall be AWWA C905 with resilient seats equal to M & H Valve NRS Style 4067 or approved equal.

23. Replacing Streets and Roadways

a. General

The Contractor(s) shall replace all streets, alleys and roadways which may be removed, disturbed, or damaged in connection with his operation under this Contract. The Contractor(s) shall reconstruct same to the original lines and grades and in such manner as to leave all such surfaces in fully as good or better condition as that which existed prior to his operations. The reuse of materials removed in making excavations will be permitted provided said materials will properly compact.

Gravel, crushed limestone, bituminous materials, or other materials used in the resurfacing of streets shall meet the current requirements of the Kentucky Department of Highways (KDH).

ANY DISTURBANCE BEYOND THE MAXIMUM ALLOWABLE WIDTH OF FIVE (5) FEET FOR PAY ITEMS WILL BE CONSIDERED CONTRACTOR'S NEGLIGENCE AND SHALL BE REPAIRED AND/OR REPLACED AT THE CONTRACTOR'S EXPENSE.

At least one-half of the traveled portion of any open cut roadways must be open to traffic at all times. Further, the Contractor(s) shall maintain traffic in at least one (1) lane at all times. No gravel trenches shall be open to traffic at any time. The Contractor(s) shall coordinate all work in traveled roadways with the city, police and fire departments. The Contractor(s) shall furnish all warning signs, barricades, channelization devices, etc., which may be required. The Contractor(s) will provide these services. All traffic control devices shall be in accordance with the manual of uniform traffic control devices, current revision. The Contractor(s) is solely responsible for job safety and he shall hold the Engineer and the Owner harmless from any claims arising thereof.

b. Backfill of Trenches Under Roadways

Replacement of streets and roadways after trenching shall be handled in the following manner:

When stone is used to backfill the trench, it shall be brought to finished grade.

The Contractor(s) shall maintain the trench by adding stone as specified and as shown on the Plans to keep the trench in a safe and passable

condition until such time that sufficient settlement has taken place and the trenches are ready for final resurfacing.

c. Traffic-Bound Base Course

After the backfill on Ohio County roads and streets has been compacted to within approximately 10 inches of finished grade as specified hereinbefore and as shown on the Plans, the Contractor(s) shall place approximately 10 inches of crushed stone, KDH dense grade aggregate (DGA), in 5-inch lifts, as a traffic-bound base course at the proper elevation to allow for settlement, but not in such a way as to present a hazard to traffic from using the roadway.

The Contractor(s) shall maintain the traffic-bound base course by adding crushed stone as specified above in a safe and passable condition for a period of sixty (60) days if dust control is provided, or until such time as sufficient settlement has taken place so that a base exists at least 6 inches thick; and trenches are ready for final resurfacing. Crushed stone added to ditches for maintenance after initial backfill will not be cause for additional payment. Crushed stone will be paid for at the unit price specified in the BID FORM.

d. Subgrade for Final Resurfacing

The traffic-bound course described above shall comprise the base course for all types of resurfacing.

When in the opinion of the Engineer, the trench has reached a condition of settlement satisfactory for final resurfacing, the Contractor(s) shall first strip the base course or backfill of crushed stone--size as specified above--to obtain the proper subgrade elevation. The subgrade shall then be rolled with an approved type roller, or tamped until thoroughly compact and 6 inches thick.

Any depressions shall be filled with crushed stone or gravel--as specified--and the process of rolling or tamping continued until the subgrade has a smooth and uniform surface.

e. Surface Restoration

The method of surface restoration shall be in accordance with the Kentucky Department of Highways Surface Restoration Methods, Drawing No. TC 99-13. A copy of TC 99-13 is included at the end of this section.

Detailed Specifications
2021 – June 2015

24. Class "C" Concrete for Kickers, Anchors and Encasements

Concrete used for anchors, kickers, and encasement shall be Class "C" concrete as called for on the Plans and Specifications.

25. Removing and Replacing Concrete Driveways and Paved Ditches

Whenever driveways are removed or disturbed in connection with the construction work, they shall be replaced to the original lines and grades in fully as good or better condition than which existed prior to the Contractor's operation.

After the sub-base has been brought to a satisfactory grade, a 3-inch layer of cinders or crushed stone shall be spread over it and thoroughly tamped. Immediately prior to pouring the concrete, the cinders or stone shall be thoroughly wetted, or the concrete shall be poured on a layer of heavy building paper.

The driveways shall consist of 6 inches of Class "A" concrete, struck off to accurately placed screeds and worked with a wooded float until the mortar appears on top. After the surface has been thoroughly floated, it shall be brushed to leave markings of a uniform type similar to the existing driveway. All joints and edges shall be finished with an edging tool. The allowable joint variation shall be 1/8-inch to 10 feet transversely and longitudinally.

Other types of driveways, such as brick, stone, asphaltic concrete, etc., shall be replaced with material removed during the progress of the work, in equally as good condition as that found before the work began.

26. Removing and Replacing Sidewalks, Curbs and Gutters

Sidewalks, curbs and gutters shall be removed and replaced to the nearest joint in each direction. The Contractor shall saw cut the sidewalk curb and gutter at the nearest sidewalk joint each side of the section to be removed. The Contractor shall take care not to damage adjacent sections of sidewalk. Adjacent sections of sidewalk damaged by the Contractor shall be repaired by replacing the entire section at the Contractor's expense.

Replacement sidewalk curb and gutter shall be reinforced and constructed in accordance with the details shown on the Plans and finished with a "broomed finish". Concrete shall be Class "A" and shall conform to the requirements of Section 3 of these Specifications.

The subgrade shall be covered with a layer of heavy waterproof paper prior to placing the concrete. Concrete sidewalks shall be five inches thick unless otherwise shown on the Plans, of the widths shown and reinforced as shown on the Plans. Control joints shall be formed at not less than five feet intervals.

Detailed Specifications
2021 – June 2015

Isolation joints with 1/2-inch width shall be installed at the intersections of all horizontal slabs and vertical surfaces and at intervals no greater than forty feet.

27. Finish Grading, Topsoiling, Seeding and Sodding

Finish grading of disturbed areas shall be performed in accordance with the finished elevations and grades shown on the Plans and shall be made to blend into conformation with remaining natural ground surfaces. All finished grading surfaces shall be left smooth and free to drain. The tops of all cuts shall have berm ditches. Selected materials, which have been obtained from stripping the site, shall be spread upon the slopes of fills and other areas inside the fence to a uniform depth and compacted suitable for planting. Excess materials shall be spread and compacted as directed. The top four (4) to six (6) inches of material in areas to be grassed shall be topsoil.

Soil tests shall be performed to determine the seed and fertilizer requirements. For the purpose of bidding, the following grass and fertilizer requirements shall be used:

Annual Rye Grass	Application rate	28 lb/acre
Kentucky Fescue #31	Application rate	28 lb/acre
Inoculated Clover	Application rate	7 lb/acre
Ammonium Nitrate	Application rate	200 lb/acre
Commercial Fertilizer	Application rate	400 lb/acre
Lime, if required	Application rate	200 lb/acre
Straw	Application rate	3,000 lb/acre

Seed shall be certified to contain not more than 3 percent weeds.

All graded areas shall be topsoiled with materials stripped from the site. If the Contractor fails to stockpile the topsoil, then material shall be brought in. The topsoil shall be left smooth and, after the fertilizer and/or lime have been distributed, it shall be disced or harrowed into the soil.

Sod shall be locally available, reasonably free of weeds and approved by the Engineer, carefully cut, transported and laid. Sod shall be so laid that no voids occur between strips. Weed roots shall be removed as the sod is laid. Sod shall be tamped or rolled immediately after it is laid, and the finished surface shall be true to grade, even and equally firm at all points. Well screened topsoil shall be lightly sprinkled over the sodded areas, and shall be raked to insure sealing the sod joints.

28. Final Clean-up

Before the work is considered as complete, all rubbish and unused material due to or connected with the construction shall be removed and the premises left in a

Detailed Specifications
2021 – June 2015

condition satisfactory to the Engineer. Final acceptance will be withheld until such work is completed.

29. Temporary Project Water Pollution Control (Soil Erosion)

See Section 1, Paragraph 37. Temporary Project Water Pollution Control (Soil Erosion).

30. BCBC Tank Control Valve and Structure

a. General

The Contractor shall furnish all equipment, materials, labor, and all other appurtenances for the construction of the BCBC Tank Control Valve Structure as specified herein and as shown on the Plans. The control valve shall consist of an electrically operated butterfly valve that operates based on inputs from the existing telemetry system. The control valve shall close when the tank is full and open at levels determined by the Owner, allowing the tank to fill. The tank shall discharge into the system when the control valve is closed through a check valve that only allows water to exit the tank. The butterfly valve shall be as specified in Paragraph 21. Butterfly Valves and Boxes as described in this section of these Detailed Specifications. The Electrical and telemetry work will be furnished by the Owner using HTI Controls of Horse Branch, Kentucky. The Contractor shall coordinate with HTI during installation and startup.

b. Precast Structure

Precast structures shall be constructed on a reinforced concrete foundation and shall be wet or dry cast as modified herein. The bottom section of the structure shall be precast integrally with the precast ring and shall be the diameter shown on the Plans. All concrete used in connection with the construction of manholes shall be Class "A" concrete as specified in Section 3 of these detailed Specifications. Wet cast precast structures shall be Sherman Dixie or equal.

Precast concrete rings shall be constructed using standard forms and shall conform to ASTM Standard Specification C478 except that:

- (1) The concrete mixture shall contain no less than 846 pounds per cubic yard (9.0 bag mix) of Portland Cement.
- (2) An eccentric top core will be allowed provided it meets these Detailed Specifications.

Detailed Specifications
2021 – June 2015

- (3) All joints shall conform to Section 8 of ASTM Designation C 361; except the Contractor(s) shall utilize a double seal of Ram-Neck as shown on the Plans.

The precast sections shall be manufactured and installed in a manner so that there is no visible leakage in the structures. The structure sections shall be manufactured in lengths such that a finished structure will have the least possible number of joints. One section less than four feet in length will be allowed per structure and that being the section required to bring the structure to grade. **NO HOLES FOR LIFTING WILL BE ALLOWED.** The precast rings shall be of the tongue and groove design sealed watertight, and the joint shall be grouted smooth on the inside and outside of the manhole so that no crack is visible.

Frames and covers shall be furnished, and set in a bed of mastic and BOLTED to the concrete as shown on the Plans. The standard frame and cover shall be traffic type of grey cast iron ASTM Designation A 48 latest revision with a 24-inch diameter opening weighing not less than 400 pounds as shown on the Plans. The covers shall be the solid self-sealing type with no holes except watertight pick notches or a heavy lifting ring. The surface between the cover and frame shall fit smoothly without rocking and shall be thoroughly cleaned. Special attention shall be given to insure the proper installation of the rubber gasket in the self-sealing cover. The gasket shall have at least 1/4-inch diameter cross-section. The frame shall be attached to the manhole barrel by means of four 5/8-inch anchor bolts and shall be set in a bed of mastic so as to constitute a watertight seal between the barrel and the frame.

Steps shall be made of copolymer polypropylene plastic meeting the latest revision of ASTM Designation D 2146 latest revision, Type II Grade 16906 and shall have a 1/2-inch diameter Grade 60 reinforcing rod meeting the latest revision of ASTM Designation A 615 through its center. Each step shall be 12 inches in width and capable of carrying a load of 1,000 pounds in the center of the step when projected 6 inches from the wall. Each step shall be equipped with non-skid grooves.

c. Check Valves

Check valves shall be of the tilting disc type and shall have cast iron body ASTM A126 Class B and shall be suitable for operation in horizontal lines. The valve shall achieve a tight closure and a non-slam characteristic by means of short disc stroke – not more than 45 degrees.

Check valves shall be flanged with flanges dimensioned and drilled ANSI Class 125 and shall be Valmatic Bulletin 9000, Apco Bulletin 800 or approved equal.

Detailed Specifications
2021 – June 2015

d. Valve Stem Extension, Supports and Accessories

Valve stem extensions shall be provided where shown on the Plans. Stem extensions shall be stainless steel meeting the requirements of ASTM Standard A276, Type 304 with operators as shown on the Plans and shall be securely fastened to the valve stem at the bottom. Stem extensions shall be of the diameter recommended by the manufacturer of the valve and must be of sufficient section to withstand any torsional or other load which will be imposed.

Stem extension guides shall be bronze bushed of the split type construction, machine bored 1/16 inch larger than the stem diameter, held to the wall by stainless steel anchor bolts and adjustable in two directions. Stem guides shall be provided as recommended by the valve and stem manufacturer.

e. Floor Boxes

Where non-rising extension stems with square nut operators are called for on the Plans extending through concrete floors or slabs, cast iron floor boxes shall be installed to provide support for the extension stem and a cover for the operating nut.

Floor boxes shall be fitted with bronze bushings and shall be Clow F-5695 or approved equal.

f. Electric Actuators

The valve actuator shall be sized to handle at least one hundred twenty-five percent (125%) of the closing torque required for sixty (60) psi differential.

Electric actuators shall meet the requirements of AWWA C-540 and the following specifications.

The electric actuator shall include the motor, operating unit gearing; limit switch gearing, limit switches, torque switches, declutch level and auxiliary handwheel as a self-contained unit.

The valve actuator motor shall be one hundred twenty (120) volt A.C. single phase, 60 hertz enclosed in a NEMA 4 enclosure with proper heaters. Provide reversing contactors. Starters are not required for single phase operation; however, a complete operable installation shall be provided including any additional details required to insure operability and reliability.

Detailed Specifications
2021 – June 2015

Motor circuit limit switches shall be of the direct break type in accordance with AWWA Standard C504. The valve actuator shall be capable of fully opening or closing the valve in sixty (60) seconds except the valves on the rate of flow controllers may be slower to prevent hunting. Closed position limit switches shall be adjustable over five (5) degrees of valve movement with a vernier screw. Open limit switches shall be adjustable over seventy-five (75) degrees of valve travel. The valve actuators shall be equipped with one (1) to 1,000 ohm feedback pot to allow remote indication of the valve's position.

Limit switches shall be provided to deenergize the motor control circuit when the actuator reaches the limit of travel in either the open or close directions. The limit switch drive shall be of the counter-gear type and shall be "in step" with the actuator output at all times in either the electrical or manual modes of operation. A minimum of six (6) contacts, three (3) normally opened and three (3) normally closed, shall be provided at each end of the valve travel.

Position control service shall be required for to 1,000 starts per hour for single phase motors with positioning accuracy to plus or minus one percent (+1%) depending upon valve operating time. These operators shall accept a 4-20 mA control signal and 1,000 ohm feedback of valve position.

Torque switches shall be wired to shut off the operator motor in the event excessive torque is being generated in either direction of travel.

The electric actuator shall be sized to be compatible with the size and type butterfly valve supplied and to provide tight closure and hold at intermediate positions. Construction of the operator shall be such that it may be mounted in any position required for manual operation.

A mechanical indicator shall be provided on the outside of the housing to continuously indicate the valve position.

A handwheel for manual operation shall be provided. When converting for manual operation, power to motor circuit shall be automatically disconnected to prevent accidental operation of the operator.

Electric actuators shall be as manufactured by EIM Company, Auma, Keystone or approved equal.

TC 99-13
Rev. 9/04

Department of Highways

KENTUCKY TRANSPORTATION CABINET

Permits Branch

SURFACE RESTORATION METHODS

Bituminous Surfacing

- NOTES:**
- SURFACE SHALL BE MILLED AND REPLACED 5 FEET PAST EDGE OF TRENCH.
 - SURFACE EDGE SHALL BE SAW CUT ON ALL REPAIRS.
 - AN APPROVED JOINT SEALER IS TO BE APPLIED BETWEEN NEW AND EXISTING PAVEMENT.

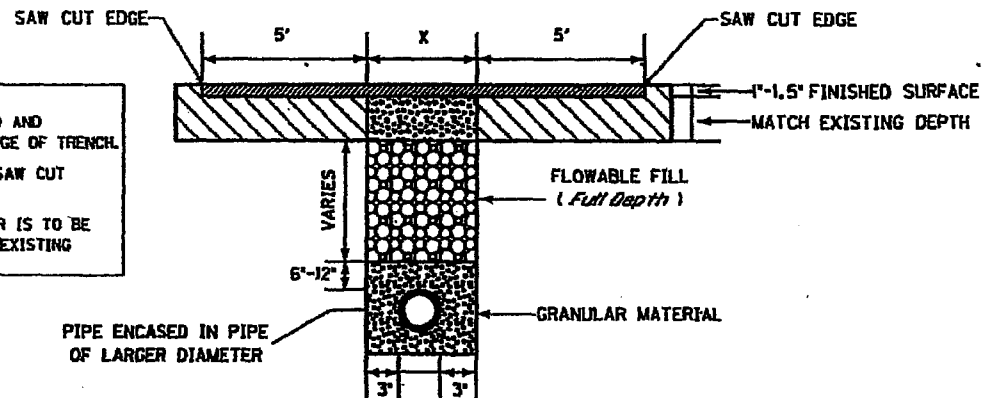

Concrete Pavement

- NOTES:**
- ALL EDGES SHALL BE SAW CUT AND SEALED WITH APPROVED JOINT SEALER.
 - DISTANCE FROM POINTS "A" (CONCRETE PAVEMENT) TO NEAREST JOINT OR BREAK IN PAVEMENT MUST BE SIX (6) FEET OR MORE. IF LESS THAN SIX (6) FEET, REMOVE PAVEMENT TO JOINT OR BREAK AND REPLACE ENTIRE SLAB.

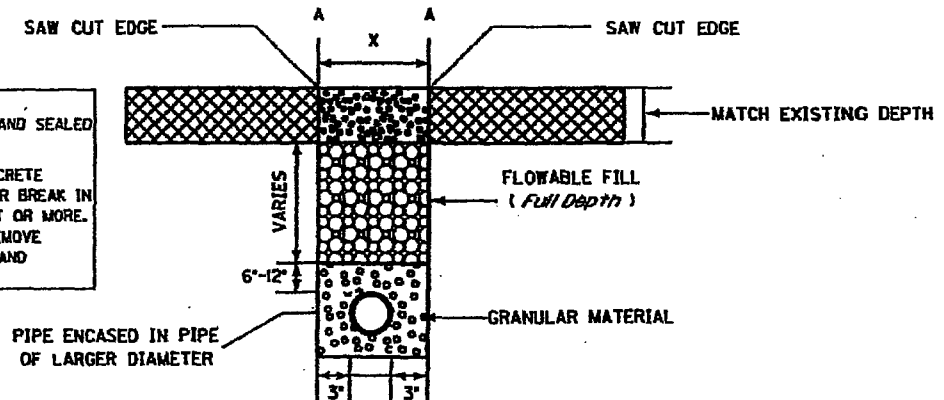

Detailed Specification
2021 – June 2015

SECTION 5

BASIS OF PAYMENT

1. General

The Contractor shall furnish all necessary tools, labor, machinery, apparatus, materials, equipment, service and other necessary supplies and do all work including all excavation and backfilling at the unit or lump sum prices for the items listed in the BID FORM.

ROCK EXCAVATION, SHEETING, SHORING AND BRACING OF EXCAVATIONS AND BEDDING AS SHOWN ON THE PLANS ARE NOT SEPARATE PAY ITEMS.

These items refer to and are the same items listed in the BID FORM, and constitute all of the pay items. Any other items of work listed in these Detailed Specifications or shown on the Plans shall be considered incidental to the following items.

2. Water Lines

Water lines where shown on the Plans or directed by the Engineer will be paid for at the contract unit price per linear foot for the class, size and type listed in the BID FORM, complete in place, including pipe, rock excavation, trenching, jointing, removal of water, crushed stone bedding as shown on the Plans, backfilling and all incidentals thereto. The quantity of water line to be paid for shall be the length of the pipe measured along the centerline of the completed pipelines without deducting the length of any tees, fittings, or air release valves. The depth of cut is measured vertically from the ground elevation at the centerline to the invert of the pipe. ROCK EXCAVATION AND BEDDING AS SHOWN ON THE PLANS ARE NOT SEPARATE PAY ITEMS.

3. Steel Casing Pipe Under Western Kentucky Parkway

Payment for installing by boring steel casing pipe under Western Kentucky Parkway as shown and specified including coordination and compliance with the Railroad's requirements including signs and incidentals will be paid for at the contract unit price per linear foot as shown in the BID FORM, complete in place.

4. Restrained Joint Pipe Installed Steel Casing Under Western Kentucky Parkway

Restrained joint ductile iron water line installed in steel casing pipe as shown on the Plans under Western Kentucky Parkway will be paid for at the contract unit

Detailed Specification
2021 – June 2015

price per linear foot as shown in the BID FORM including assembly, insertion, casing spacers and all incidentals, complete in place.

5. Butterfly Valves and Boxes

Payment for furnishing and installing butterfly valves and boxes of the size shown in the BID FORM will be made at the contract unit price each, including valve assembly, box, and 2'-0" square 6-inch thick concrete pad and cast aluminum plaque, complete in place.

6. Tapping Sleeve and Valve

Tapping sleeves and valves will be paid for at the contract unit price shown in the BID FORM, complete in place, including the tapping sleeve, valve, valve box, and any required connecting. ALL OTHER CONNECTIONS TO THE EXISTING SYSTEM WILL NOT BE A SPEARATE PAY ITEM AND THE COST OF SUCH OTHER CONNECTIONS SHALL BE MERGED INTO THE COST OF THE LINES UNLESS OTHERWISE SPECIFIED OR SHOWN.

7. Air Release Valves and Boxes

Payment for furnishing and installing combination air and vacuum release valves of the sizes shown and boxes will be made at the contract unit price each as specified in the BID FORM, complete in place.

8. Connections to Existing Water Lines

Payment for making connections including furnishing and installing all fittings, valves, pipe and appurtenances of the sizes and at the locations shown on the Plans will be made at the lump sum contract price as shown in the BID FORM, complete in place.

9. Fire Hydrants

New fire hydrants where shown on the Plans shall be furnished and installed and will be paid for at the contract unit price each shown in the BID FORM, complete in place, including the hydrant, any barrel extensions required, the six-inch gate valve and box, the main line fitting and up to 20 L.F. of 6-inch Class 350 D.I.P. and other appurtenances as specified and shown on the Plans.

10. Undercutting Where Directed by Engineer

Where undercutting and stone refill of the trench is directed by the Engineer, the crushed stone used to bring the trench back to grade will be paid for at the contract unit price per cubic yard as shown in the BID FORM. The quantity will be computed from a plane six inches (6") below the invert of the pipe to the bottom

Detailed Specification
2021 – June 2015

of the ordered extra excavation using the actual ditch width but not exceeding the maximum width allowed by these Detailed Specifications. Excavation of undercutting is NOT a separate pay item. The Contractor will furnish the Engineer a duplicate weigh slip for all such undercutting material delivered to the job for records as a check on computations.

11. KYTC No. 57 Crushed Stone for Ditch Backfill Under Paved Surfaces Where Required by the Engineer

Where directed by the Engineer, KYTC No. 57 crushed stone backfill above the water line pipe bedding as shown on the Plans or specified hereinbefore will be paid for at the contract unit price per theoretical cubic yard of material furnished and placed, and mechanically tamped in 6-inch layers, as shown in the BID FORM. The theoretical quantity will be computed from the bottom of the ditch to the completed surface using either the actual ditch width or the maximum specified width of the ditch, whichever is smaller. The specified trench width is the nominal diameter of pipe plus 18 inches. ANY ADDITIONAL TRENCH WIDTH WILL BE CONSIDERED OVER-BREAKAGE WHICH SHALL BE BACKFILLED AT THE CONTRACTOR'S EXPENSE.

12. Dense Grade Aggregate Crushed Stone for Traffic Bound Surfacing, Base Course and/or Backfill Where Required by the Engineer

Where directed by the Engineer, crushed stone backfill above the water line pipe bedding as shown on the Plans or specified hereinbefore will be paid for at the contract unit price per theoretical cubic yard of material furnished and placed, and mechanically tamped in 6-inch layers, as shown in the BID FORM. The theoretical quantity will be computed from the bottom of the ditch to the completed surface using either the actual ditch width or the maximum specified width of the ditch, whichever is smaller. The specified trench width is the nominal diameter of pipe plus 18 inches.

ANY ADDITIONAL TRENCH WIDTH WILL BE CONSIDERED OVER-BREAKAGE WHICH SHALL BE BACKFILLED AT THE CONTRACTOR'S EXPENSE.

13. Flowable Fill for Backfill Where Required by the Engineer

Where directed by the Engineer, flowable fill backfill above the water line pipe bedding as shown on the Plans or specified hereinbefore will be paid for at the contract unit price per theoretical cubic yard of material furnished and placed, as shown in the BID FORM. The theoretical quantity will be computed from the bottom of the ditch to the completed surface using either the actual ditch width or the maximum specified width of the ditch, whichever is smaller. The specified trench width is the nominal diameter of pipe plus 18 inches. ANY ADDITIONAL

Detailed Specification
2021 – June 2015

TRENCH WIDTH WILL BE CONSIDERED OVER-BREAKAGE WHICH SHALL BE BACKFILLED AT THE CONTRACTOR'S EXPENSE.

14. Class "C" Concrete for Cradles, Anchors and Encasement

Class "C" concrete for kickers, anchors, and encasement will be paid for at the contract unit price per cubic yard shown in the BID FORM, complete in place. The price of any necessary bolts, strips or other metal fittings shall be included in the cost of the concrete.

15. Asphaltic Concrete Pavement

Asphaltic concrete pavement will be paid for at the contract unit price per cubic yard shown in the BID FORM, complete in place, including primer. The Contractor(s) shall replace all other damaged pavement at his own expense.

ANY DISTURBANCE BEYOND THE MAXIMUM ALLOWABLE WIDTH OF FIVE (5) FEET FOR PAY ITEMS WILL BE CONSIDERED CONTRACTOR'S NEGLIGENCE AND SHALL BE REPAIRED AND/OR REPLACED AT THE CONTRACTOR'S EXPENSE.

16. Temporary Silt Fence

Temporary silt fence with hay or straw bales installed as shown on the Plans or as directed by the Engineer will be paid for, complete in place, at the contract unit price shown in the BID FORM per linear foot, including removal of the temporary silt fence and hay or straw bales within the one year warranty period and at the direction of the Engineer.

17. Steel Marker Posts

Payment for furnishing and installing steel marker posts will be made at the contract unit price each as specified in the BID FORM, complete in place, including steel pipe, concrete, and paint and lettering.

18. BCBC Tank Control Valve and Structure

Payment for furnishing and installing the BCBC Tank Control Valve and Structure will be made at the lump sum price indicated in the BID FORM, complete in place, including all pipe, fittings, valves, floor stand, floor box, electric operator, drain pipe, and precast concrete vault.

BID FORM
2021 – June 2015

BID FORM

- An Individual ()
- A Partnership ()
- A Corporation ()
- A Limited Liability Corporation ()

Date _____

1. BID for construction of Water System Improvements for the Ohio County Water District as Owner.

TO THE OHIO COUNTY WATER DISTRICT:

I
WE _____
Name of Bidder

Address of Bidder

The undersigned, as bidder, proposes to furnish all necessary labor, machinery, tools, apparatus, materials, equipment, service and other necessary supplies, in strict accordance with the terms and conditions of the Detailed Specifications, Contract Documents and the Plans hereto attached and referred to herein for the construction of Water System Improvements, Contract 15-01 – 16-inch North Water Transmission Line, Phase I, and do such other work incidental thereto as may be ordered by the Engineer, at the unit or lump sum prices listed herein.

2. The Bidder declares that he has examined the sites of the work and informed himself fully in regard to all conditions pertaining to the places where the work is to be done; that he has examined these Detailed Specifications and Contract Documents for the work and has read all special provisions furnished prior to the opening of bids; and that he has satisfied himself relative to the work to be performed. The Bidder further declares that he understands the unit price work is subject to increase or decrease, and that should the scope of any of the items of work be changed materially, the undersigned proposes to do the additional work using the unit prices set out herein. Should the quantities be decreased the undersigned will make no claim for anticipated profits.
3. BIDS shall include sales tax and all other applicable taxes and fees.
4. Amounts are to be shown in both words and figures. In case of discrepancy, the amount shown in words will govern.

BID FORM
2021 – June 2015

5. The unit and lump sum prices shall include all labor, materials, shoring, overhead, profit, insurance, *etc.*, to cover the finished work of the several kinds called for.
6. The Bidder understands that the Owner reserves the right to reject any or all bids and to waive any informalities in the bidding.
7. The Bidder agrees that his Bid shall be good and may not be withdrawn for a period of 90 calendar days after the scheduled closing time for receiving bids.

BID FORM
2021 – June 2015

8. BID FORM A: CONTRACT 15-01
16-INCH NORTH WATER TRANSMISSION LINE -- PHASE I

ITEM NUMBER	APPROXIMATE QUANTITY	DESCRIPTION WITH UNIT BID PRICE WRITTEN IN WORDS	UNIT PRICE	TOTAL PRICE
1.	Lump Sum	Connection No. 1 – connection to existing 8- and 16-inch water line for line “W- 1” at Sta. 0+00± including two 16-inch butterfly valves, all pipe and fittings as required for connection, steel marker posts, and all excavation and appurtenances as shown on the Plans and as specified herein, complete in place For _____ _____ Dollars _____ Cents, lump sum	\$	_____
2.	Lump Sum	Connection No. 2 – connection to existing 10-inch water line for line “W-1” at Sta. 45+87 including 10-inch tapping sleeve and valve, 16- inch butterfly valve, all pipe and fittings as required, steel marker posts, and all excavation and appurtenances as shown on the Plans and as specified herein, complete in place For _____ _____ Dollars _____ Cents, lump sum	\$	_____

BID FORM
2021 – June 2015

8. BID FORM A: CONTRACT 15-01
16-INCH NORTH WATER TRANSMISSION LINE – PHASE I (Cont'd)

ITEM NUMBER	APPROXIMATE QUANTITY	DESCRIPTION WITH UNIT BID PRICE WRITTEN IN WORDS	UNIT PRICE	TOTAL PRICE
3.	Lump Sum	Connection No. 3 – connection to existing 12-inch water line for line "W-1" at Sta. 158+76 including one 12-inch tapping sleeve and gate valve, all pipe and fittings as required for connection, steel marker posts, and all excavation and appurtenances as shown on the Plans and as specified herein, complete in place For _____ _____ Dollars _____ Cents, lump sum		\$ _____
4.	Lump Sum	BCBC Tank Control Valve and Vault including precast vault, pipe, valves, floor stand and electric operator, complete in place including excavation, valve installation, and appurtenances as required For _____ _____ Dollars _____ Cents, lump sum		\$ _____

BID FORM
2021 – June 2015

8. BID FORM A: CONTRACT 15-01
16-INCH NORTH WATER TRANSMISSION LINE – PHASE I (Cont'd)

ITEM NUMBER	APPROXIMATE QUANTITY	DESCRIPTION WITH UNIT BID PRICE WRITTEN IN WORDS	UNIT PRICE	TOTAL PRICE
5.	12,226 L.F.	Furnish and install 16-inch DR 21 C905 PVC Water Line, including fittings, excavation and bedding materials as shown on the Plans and as specified herein, complete in place For _____ _____ Dollars _____ Cents, per linear foot	\$ _____	\$ _____
6.	3,450 L.F.	Install 16-inch Pressure Class 250 D.I.P. Water Line, including fittings, excavation and bedding materials as shown on the Plans and as specified herein, complete in place For _____ _____ Dollars _____ Cents, per linear foot	\$ _____	\$ _____

BID FORM
2021 – June 2015

8. BID FORM A: CONTRACT 15-01
16-INCH NORTH WATER TRANSMISSION LINE – PHASE I (Cont'd)

ITEM NUMBER	APPROXIMATE QUANTITY	DESCRIPTION WITH UNIT BID PRICE WRITTEN IN WORDS	UNIT PRICE	TOTAL PRICE
7.	185 L.F.	24-inch Steel Casing Pipe, 0.500-inch minimum wall thickness bored under Western Kentucky Parkway, including all incidentals except for carrier pipe as shown on the Plans and specified herein, complete in place For _____	\$	\$
		Dollars _____ Cents, per linear foot		
8.	195 L.F.	16-inch Class 250 R.J.D.I.P. Water Line installed in 24-inch Steel Casing Pipe under Western Kentucky Parkway, including casing spacers, all excavation and bedding as shown on the Plans and specified herein, complete in place For _____	\$	\$
		Dollars _____ Cents, per linear foot		

BID FORM
2021 – June 2015

8. BID FORM A: CONTRACT 15-01
16-INCH NORTH WATER TRANSMISSION LINE – PHASE I (Cont'd)

ITEM NUMBER	APPROXIMATE QUANTITY	DESCRIPTION WITH UNIT BID PRICE WRITTEN IN WORDS	UNIT PRICE	TOTAL PRICE
9.	3 Each	Fire Hydrants complete as shown on the Detail on the Plans including Main Line Tee and kicker, 6-inch gate valve, concrete kicker and assembly, and up to 20 L.F. of 6-inch pipe (KYTC No. 57 crushed stone and Class "C" concrete will be paid for at unit prices) as shown on the Plans and as specified herein, complete in place For _____ _____ Dollars _____ Cents, each	\$ _____	\$ _____
10.	11 Each	Air Release Valve Assemblies, including air valve, precast vault, all pipe and fittings, complete in place, as shown on the Plans and specified herein For _____ _____ Dollars _____ Cents, each	\$ _____	\$ _____

BID FORM
2021 – June 2015

8. BID FORM A: CONTRACT 15-01
16-INCH NORTH WATER TRANSMISSION LINE – PHASE I (Cont'd)

ITEM NUMBER	APPROXIMATE QUANTITY	DESCRIPTION WITH UNIT BID PRICE WRITTEN IN WORDS	UNIT PRICE	TOTAL PRICE
11.	3 Each	16-inch Butterfly Valve Assembly, including valve, valve box, and concrete pad, complete in place, as shown on the Plans and specified herein For _____ _____ Dollars _____ Cents, each	\$ _____	\$ _____
12.	100 C.Y.	Dense Grade Aggregate Crushed Stone for Traffic Bound Surfacing or Base Course meeting the requirements of the Kentucky Department of Highways as shown on the Plans or where directed by the Engineer For _____ _____ Dollars _____ Cents, per cubic yard	\$ _____	\$ _____
13.	200 C.Y.	KYTC No. 57 Crushed Stone for ditch backfill under paved surfaces or where directed by the Engineer For _____ _____ Dollars _____ Cents, per cubic yard	\$ _____	\$ _____

BID FORM
2021 – June 2015

8. BID FORM A: CONTRACT 15-01
16-INCH NORTH WATER TRANSMISSION LINE – PHASE I (Cont'd)

ITEM NUMBER	APPROXIMATE QUANTITY	DESCRIPTION WITH UNIT BID PRICE WRITTEN IN WORDS	UNIT PRICE	TOTAL PRICE
14.	50 C.Y.	Flowable fill backfill in accordance with KYTC requirements For _____ _____ Dollars _____ Cents, per cubic yard	\$ _____	\$ _____
15.	100 C.Y.	Class "C" Concrete for Kickers, Anchors and Encasements or where directed by the Engineer For _____ _____ Dollars _____ Cents, per cubic yard	\$ _____	\$ _____
16.	10,000 L.F.	Standard temporary Silt Fence with Hay or Straw Bales, complete in place as shown on the Plans or where directed by the Engineer For _____ _____ Dollars _____ Cents, per linear foot	\$ _____	\$ _____
17.	100 C.Y.	Asphaltic concrete pavement binder course in accordance with KYTC surface restoration TC-99-13 where directed by the Engineer or shown on the Plans For _____ _____ Dollars _____ Cents, per cubic yard	\$ _____	\$ _____

BID FORM
2021 – June 2015

8. BID FORM A: CONTRACT 15-01
16-INCH NORTH WATER TRANSMISSION LINE – PHASE I (Cont'd)

ITEM NUMBER	APPROXIMATE QUANTITY	DESCRIPTION WITH UNIT BID PRICE WRITTEN IN WORDS	UNIT PRICE	TOTAL PRICE
18.	50 C.Y.	Asphaltic concrete pavement topping in accordance with KYTC surface restoration TC- 99-13 where directed by the Engineer or shown on the Plans For _____ _____ Dollars _____ Cents, per cubic yard	\$ _____	\$ _____
19.	28 Each	Steel Marker Post installed at the locations specified herein, complete in place including excavation, valve installation, and appurtenances as required For _____ _____ Dollars _____ Cents, per each	\$ _____	\$ _____
TOTAL BID AMOUNT CONTRACT NUMBER 15-01 ITEMS 1 – 19			\$ _____	

BID FORM
2021 – June 2015

9. Time of Commencement and Completion

The Bidder further proposes and agrees hereby to commence the work with adequate force and equipment on a date to be specified in a written order of the Engineer, and complete all work within the calendar days shown:

CONTRACT 15-01:

The Contractor for Contract 15-01 is allowed two hundred seventy (270) calendar days to complete all work under this contract.

10. Liquidated Damages

The Bidder further understands that if the work is not completed within the time specified, that any additional engineering and resident construction observation costs incurred by the Owner due to the Contractor exceeding the time allowed for completion plus other damages, including the revenue lost from the project's water customers, will be deducted on a per calendar day basis from the compensation otherwise due him in accordance with the General Conditions for each day thereafter, Sundays and holidays included, that work remains uncompleted.

The following sum is agreed by the parties to be liquidated damages:

One Thousand (\$1,000.00) Dollars per calendar day

11. Time Limit for Execution of Documents

The undersigned further agrees that, in case of failure on his part to execute the Contract and the Bond(s) in the six (6) counterparts within ten (10) consecutive calendar days after written notice being given of the award of the Contract, the check or bid bond accompanying this bid and the monies payable thereon shall be paid into the funds of the Ohio County Water District as liquidated damages for such failure; otherwise the check or bid bond accompanying this BID FORM shall be returned to the undersigned.

12. Bid Guaranty

Attached hereto is a certified check on the _____
Bank of _____ or a Bid Bond on the form
provided for the sum of 5% of Bid Dollars (\$_____) made payable to
the Ohio County Water District to insure that the Contractor will enter into
the Construction Contract and Contract Bond.

BID FORM
2021 – June 2015

13. Interested Parties

The undersigned, as Bidder, hereby declares that the only person or persons interested in the BID FORM as principal or principals is or are named herein, and that no other person herein mentioned has any interest in this BID FORM or in the Contract to be entered into; that this BID FORM is made without connection with any other person, company, or parties making a bid or proposal and that it is in all respects fair and in good faith without collusion or fraud.

<u>NAME</u>	<u>ADDRESS</u>
_____	_____
_____	_____
_____	_____

14. Addenda

I hereby certify that I have received, read and examined the following numbered Addenda: _____, _____, _____, _____, _____, _____, _____.

BY: _____
Name of Bidder

Address of Bidder

Signature of Authorized Representative

Title

ATTEST (For Corporations)

(Name)

Title

Solicitation/Contract #: _____

**REQUIRED AFFIDAVIT FOR BIDDERS, OFFERORS AND CONTRACTORS
CLAIMING RESIDENT BIDDER STATUS**

FOR BIDS AND CONTRACTS IN GENERAL:

The bidder or offeror hereby swears and affirms under penalty of perjury that, in accordance with KRS 45A.494(2), the entity bidding is an individual, partnership, association, corporation, or other business entity that, on the date the contract is first advertised or announced as available for bidding:

1. Is authorized to transact business in the Commonwealth;
2. Has for one year prior to and through the date of advertisement
 - a. Filed Kentucky income taxes;
 - b. Made payments to the Kentucky unemployment insurance fund established in KRS 341.49; and
 - c. Maintained a Kentucky workers' compensation policy in effect.

The BIDDING AGENCY reserves the right to request documentation supporting a bidder's claim of resident bidder status. Failure to provide such documentation upon request may result in disqualification of the bidder or contract termination.

Signature

Printed Name

Title

Date

Company Name _____

Address _____

Subscribed and sworn to before me by _____
(Affiant) (Title)

of _____ this _____ day of _____, 20____.
(Company Name)

Notary Public
[Seal of Notary]

My Commission Expires

Check this box if not claiming Resident Bidder Status

Solicitation/Contract #: _____

REQUIRED AFFIDAVIT FOR BIDDERS, OFFERORS AND CONTRACTORS
CLAIMING QUALIFIED BIDDER STATUS

FOR BIDS AND CONTRACTS IN GENERAL:

I. The bidder or offeror swears and affirms under penalty of perjury that the entity bidding, and all subcontractors therein, meets the requirements to be considered a "qualified bidder" in accordance with 200 KAR 5:410(3); and will continue to comply with such requirements for the duration of any contract awarded. Please identify below the particular "qualified bidder" status claimed by the bidding entity.

_____ A nonprofit corporation that furthers the purposes of KRS Chapter 163

_____ Per KRS 45A.465 (3), a "Qualified nonprofit agency for individuals with severe disabilities" means an organization that:

- (a) Is organized and operated in the interest of individuals with severe disabilities; and
- (b) Complies with any applicable occupational health and safety law of the United States and the Commonwealth; and
- (c) In the manufacture or provision of products or services listed or purchased under KRS 45A.470, during the fiscal year employs individuals with severe disabilities for not less than seventy-five percent (75%) of the man hours of direct labor required for the manufacture or provision of the products or services; and
- (d) Is registered and in good standing as a nonprofit organization with the Secretary of State.

The BIDDING AGENCY reserves the right to request documentation supporting a bidder's claim of qualified bidder status. Failure to provide such documentation upon request may result in disqualification of the bidder or contract termination.

Signature

Printed Name

Title

Date

Company Name

Address

Subscribed and sworn to before me by _____ this _____
day of _____, 20____.

Notary Public
[Seal of Notary]

My Commission Expires

Check this box if not claiming Qualified Bidder Status

BID BOND
2021 – June 2015

BID BOND

KNOW ALL MEN BY THESE PRESENTS, that we, the undersigned,

_____ as
Principal, and _____ as
Surety, are hereby held and firmly bound unto the Ohio County Water District, as Owner,
in the penal sum of:

_____ or the payment of which, well and truly to be made, we hereby jointly and severally bind ourselves, our heirs, executors, administrators, successors and assigns.

Signed this _____ day of _____, 20____.

The condition of the above obligation is such that whereas the Principal has submitted to the Ohio County Water District, a certain BID, attached hereto and made a part hereof to enter into Contract in writing for the construction of Water System Improvements, Contract No. 15-01 – 16-inch North Water Transmission Line – Phase I for the Ohio County Water District, Ohio County, Kentucky.

NOW THEREFORE,

- (a) If said Bid shall be rejected, or in the alternate,
- (b) If said Bid shall be accepted and the Principal shall execute and deliver a Contract in the Form of Contract attached hereto (properly completed in accordance with said Bid) and shall furnish a bond for his faithful performance of said Contract, and for the payment of all persons performing labor or furnishing materials in connection therewith, and shall in all other respects perform the agreement created by the acceptance of said BID, then this obligation shall be void, otherwise the same shall remain in force and effect, it being expressly understood and agreed that the liability of the Surety for any and all claims hereunder shall, in no event, exceed the penal amount of this obligation as herein stated.

The Surety, for value received, hereby stipulates and agrees that the obligations of said Surety and its bond shall be in no way impaired or affected by any extension of the time within which the Owner may accept such BID; and said Surety does hereby waive notice of any such extension.

BID BOND
2021 – June 2015

IN WITNESS WHEREOF, the Principal and the Surety have hereunto set their hands and seals, and such of them as are corporations have caused their corporate seals to be hereto affixed and these presents to be signed by their proper officers, the day and year first set forth above.

Principal

Firm Name

BY:

Signature

Printed Name

ADDRESS:

Seal

Surety

Firm Name

BY:

Signature

Printed Name

ADDRESS:

Seal

BID BOND
2021 – June 2015

NOTE: A copy of the Power of Attorney of the Surety's Principal is required and the amount of the bond must not be less than five percent (5%) of the amount of bid.

Surety companies executing bonds must appear on the Treasury Department's most current list (Circular 570 as amended) and be authorized to transact business in the State where the project is located.

AGREEMENT
2021 – June 2015

AGREEMENT

THIS AGREEMENT made and entered into this the ____ day of _____,
20____, by and between _____
doing business as _____
(an individual) or (a partnership) or (a corporation)

hereinafter called the Contractor, and the Ohio County Water District, Ohio County,
Kentucky hereinafter called the Owner:

WITNESSETH:

That the Contractor, for the consideration hereinafter fully set out, hereby agrees
with the Owner as follows:

1. Scope of the Work

That the Contractor shall furnish all labor, materials, tools, machinery and service,
to complete the construction of Water System Improvements, Contract 15-01 – 16-
inch North Water Transmission Line – Phase I for the Owner, in the manner and
form as provided by the Detailed Specifications and Documents attached hereto
and enumerated as follows:

a. Plans – Contract 15-01

Ohio County Water District, Water System Improvements, Contract 15-01 –
16-inch North Water Transmission Line – Phase I, Sheets 1 through 14.

b. Specifications and Contract Documents

	<u>Pages</u>
(1) Advertisement for Bids	AB 1 – 3
(2) Instructions to Bidders	IB 1 – 11
(3) General Conditions	GC 1 – 69
(4) Supplementary Conditions – Kentucky – SRF	SC 1 – 2
(5) A Listing of the Duties, Responsibilities and Limitations of Authority of the Resident Project Representative	1 – 4
(6) Supplemental General Conditions for Clean Water State Revolving Fund, Drinking Water State Revolving Fund	1 – 52
(7) Davis-Bacon Wage Rate	
(8) Kentucky Department of Labor Prevailing Wage Rate	
(9) Detailed Specifications	
Section 1 – General Scope and Special Provisions SWPPP	DS 1, 1 – 13
Section 2 – Testing and Control of Materials	DS 2, 1 – 9
Section 3 – Concrete and Reinforcing Steel	DS 3, 1 – 27
Section 4 – Water Line and Appurtenances Surface Restoration Methods	DS 4, 1 – 26
Section 5 – Basis of Payment	DS 5, 1 – 4
(10) BID FORM	BF, 1 – 12
Required Affidavit for Bidders, Offerors and Contractors Claiming Resident Bidder Status	
Required Affidavit for Bidders, Offerors and Contractors Claiming Qualified Bidder Status	
(11) Bid Bond	BB, 1 – 3
(12) Agreement	A, 1 – 8
(13) Performance Bond	PEB, 1 – 2
(14) Payment Bond	PAB, 1 – 2
(15) Addenda _____, _____, _____, _____, _____, _____	

all identified as Water System Improvements for the Ohio County Water District,
Contract 15-01 – 16-inch North Water Transmission Line – Phase I, Job Number
2021, June 2015 as prepared by the Engineer, J. R. Wauford & Company

AGREEMENT
2021 – June 2015

Consulting Engineers, Inc., Nashville, Tennessee, and shall do everything required by this Agreement, Advertisement for Bids, Instructions to Bidders, General Conditions, Detailed Specifications, BID FORM, Payment Bond, Performance Bond, and Addenda.

2. Time for Commencement and Completion

That the Contractor shall commence the work to be performed under this Agreement on written order of the Engineer, and shall fully complete all work hereunder within the following number of consecutive calendar days from and including said date.

Contract 15-01 – Two Hundred Seventy (270) calendar days

3. Payments

The Owner hereby agrees to pay to the Contractor for the faithful performance of this Agreement, subject to additions and deductions as provided in the Detailed Specifications and Contract Documents, in lawful money of the United States, as follows:

the full sum of _____ Dollars

_____ Cents (\$_____).

4. Current Estimates

The Owner shall make partial payments to the Contractor on the basis of a duly certified and approved estimate of work performed during the preceding calendar month by the Contractor, less ten (10) percent of the amount of such estimate which is to be retained by the Owner until all work has been performed strictly in accordance with this Agreement and until such work has been accepted by the Owner. Upon request by the Contractor, total retainage shall be reduced to five (5) percent of the total revised Contract Amount after the Contract is at least 50 percent complete.

5. Final Estimates

Upon submission by the Contractor of evidence satisfactory to the Owner that all payrolls, material bills, and other costs incurred by the Contractor in connection with the construction of the work have been paid in full, final payment on account of this Agreement shall be made after the completion by the Contractor of all work covered by this Agreement, and the acceptance of such work by the Owner.

6. Liquidated Damages

It is mutually agreed between the parties hereto that time is the essence on each and every portion of this Contract. If the said Contractor shall neglect, fail or refuse to complete the work within the time specified within the Contract, or within any proper extension thereof granted by the Owner, then the Contractor does

AGREEMENT
2021 – June 2015

hereby agree to pay, either by means of deduction from the compensation due the Contractor under this Contract or by direct payment by the Contractor to the Owner, not as a penalty, but as liquidated damages, the sum of One Thousand (\$1,000.00) Dollars, per calendar day for each day thereafter, Sundays and Holidays included, that the work remains incomplete. In addition, any fines paid as a result of the Contractor's failure to complete the project on time or neglect shall be borne by the Contractor.

7. Additional Bond

It is further mutually agreed between the parties hereto that if, at any time after the execution of this Agreement and the Surety Bond hereto attached for its faithful performance, the Owner shall deem the surety or sureties upon such bond to be unsatisfactory, or if for any reason such bond ceases to be adequate to cover the performance of the work, the Contractor shall, at his expense, within five days after the receipt of notice from the Owner so to do, furnish an additional bond or bonds in such form and amount, and with such surety or sureties as shall be satisfactory to the Owner. In such event, no further payment to the Contractor shall be deemed to be due under this Agreement until such new or additional security for the faithful performance of the work shall be furnished in manner and form satisfactory to the Owner.

AGREEMENT
2021 – June 2015

8. Buy American

The Contractor acknowledges to and for the benefit of the Ohio County Water District (“Purchaser”) and the Commonwealth of Kentucky (the “State”) that it understands the goods and services under this Agreement are being funded with monies made available by the Clean Water State Revolving Fund and/or Drinking Water State Revolving Fund that have statutory requirements commonly known as “American Iron and Steel” that requires all of the iron and steel products used in the project to be produced in the United States (“American Iron and Steel Requirement”) including iron and steel products provided by the Contractor pursuant to this Agreement. The Contractor hereby represents and warrants to and for the benefit of the Purchaser and the State that (a) the Contractor has reviewed and understands the American Iron and Steel Requirement, (b) all of the iron and steel products used in the project will be and/or have been produced in the United States in a manner that complies with the American Iron and Steel Requirement, unless a waiver of the requirement is approved, and (c) the Contractor will provide any further verified information, certification or assurance of compliance with this paragraph, or information necessary to support a waiver of the American Iron and Steel Requirement, as may be requested by the Purchaser or the State. Notwithstanding any other provision of this Agreement, any failure to comply with this paragraph by the Contractor shall permit the Purchaser or State to recover as damages against the Contractor any loss, expense or cost (including without limitation any impairment or loss of funding, whether in whole or in part,

AGREEMENT
2021 – June 2015

from the State or any damages owed to the State by the Purchaser). While the contractor has no direct contractual privity with the State, as a lender to the Purchaser for the funding of its project, the Purchaser and the Contractor agree that the State is a third-party beneficiary and neither this paragraph (nor any other provision of this Agreement necessary to give this paragraph force or effect) shall be amended or waived without the prior written consent of the State.

IN WITNESS WHEREOF the parties hereto have executed this Agreement on the day and date first above written in 6 counterparts, each of which shall, without proof or accounting for the other counterparts, be deemed an original contract.

AGREEMENT
2021 – June 2015

CONTRACTOR: _____

BY: _____

NAME: _____

(PLEASE TYPE)

TITLE: _____

(SEAL)

ATTEST OR WITNESS:

NAME: _____

(PLEASE TYPE)

OWNER: OHIO COUNTY WATER DISTRICT
HARTFORD, KENTUCKY

BY: _____

NAME: _____

(PLEASE TYPE)

TITLE: _____

(SEAL)

ATTEST:

NAME: _____

(PLEASE TYPE)

PERFORMANCE BOND
2021 – June 2015

BOND # _____

PERFORMANCE BOND

KNOW ALL MEN BY THESE PRESENTS: that

(Name of Contractor)

(Address of Contractor)

a _____ hereinafter called
(Corporation, Partnership or Individual)

Principal, and _____
(Name of Surety)

(Address of Surety)

hereinafter called "Surety", are held and firmly bound unto

Ohio County Water District
(Name of Owner)

124 East Washington Street, Hartford, Kentucky 42437
(Address of Owner)

hereinafter called "Owner", in the penal sum of _____
Dollars _____ Cents (\$ _____) in lawful money of the United States, for the
payment of which sum well and truly to be made, we bind ourselves, successors, and
assigns, jointly and severally, firmly by these presents.

THE CONDITION OF THIS OBLIGATION is such that whereas, the Principal
entered into a certain contract with the Owner, dated the _____ day of _____,
20____, a copy of which is hereto attached and made a part hereof for the construction
of:

Water System Improvements
Contract 15-01 – 16-inch North Water Transmission Line – Phase I
JRWCO Job No. 2021

NOW, THEREFORE, if the Principal shall well, truly and faithfully performs its
duties, all the undertakings, covenants, terms, conditions, and agreements of said
contract during the original term thereof, and any extensions thereof which may be
granted by the Owner, with or without notice to the Surety, and if he shall satisfy all
claims and demands incurred under such contract, and shall fully indemnify and save
harmless the Owner from all cost and damages which it may suffer by reason of failure
to do, and shall reimburse and repay the Owner all outlay and expense which the Owner
may incur in making good any default, then this obligation shall be void; otherwise to
remain in full force and effect.

PERFORMANCE BOND
2021 – June 2015

PROVIDED, FURTHER, that the said surety, for value received hereby stipulates and agrees that no change, extension of time, alteration or addition to the terms of the contract or to the work to be performed thereunder or the specifications accompanying the same shall in any wise affect its obligation on this bond, and it does hereby waive notice of any such change, extension of time, alteration or addition to the terms of the contract or to the work or to the specifications.

PROVIDED, FURTHER, that no final settlement between the Owner and the Contractor shall abridge the right of any beneficiary hereunder, whose claim may be unsatisfied.

IN WITNESS WHEREOF, this instrument is executed in 6 counterparts, each one of which shall be deemed an original, this the ____ day of _____, 20____.

WITNESSES:

_____ Principal

_____ BY: _____

_____ Address

(SEAL)

WITNESSES:

_____ Surety

_____ BY: _____

Attorney-in-Fact

NOTE: Surety companies executing bonds must appear on the Treasury Department's most current list (Circular 570 as amended) and be authorized to transact business in the state where the project is located.

PAYMENT BOND
2021 – June 2015

BOND # _____

PAYMENT BOND

KNOW ALL MEN BY THESE PRESENTS: that

(Name of Contractor)

(Address of Contractor)

a _____ hereinafter called
(Corporation, Partnership or Individual)

Principal, and _____
(Name of Surety)

(Address of Surety)

hereinafter called "Surety", are held and firmly bound unto

Ohio County Water District
(Name of Owner)

124 East Washington Street, Hartford, Kentucky 42437
(Address of Owner)

hereinafter called "Owner", in the penal sum of _____
Dollars _____ Cents (\$ _____) in lawful money of the United States, for the
payment of which sum well and truly to be made, we bind ourselves, successors, and
assigns, jointly and severally, firmly by these presents.

THE CONDITION OF THIS OBLIGATION is such that whereas, the Principal
entered into a certain contract with the Owner, dated the _____ day of _____,
20____, a copy of which is hereto attached and made a part hereof for the construction
of:

Water System Improvements
Contract 15-01 – 16-inch North Water Transmission Line – Phase I
JRWCO Job No. 2021

NOW, THEREFORE, if the Principal shall promptly make payment to all persons,
firms, subcontractors, and corporations furnishing materials for or performing labor in
the prosecution of the work provided for in such contract, and any authorized extension
or modification thereof, including all amounts due for materials, lubricants, oil, gasoline,
coal and coke, repairs on machinery, equipment and tools consumed or used in
connection with the construction of such work, and all insurance premiums on said work,
and for all labor, performed in such work whether by subcontractor or otherwise, then
this obligation shall be void; otherwise to remain in full force and effect.

PAYMENT BOND
2021 – June 2015

PROVIDED, FURTHER, that the said surety, for value received hereby stipulates and agrees that no change, extension of time, alteration or addition to the terms of the contract or to the work to be performed thereunder or the specifications accompanying the same shall in any wise affect its obligation on this bond, and it does hereby waive notice of any such change, extension of time, alteration or addition to the terms of the contract or to the work or to the specifications.

PROVIDED, FURTHER, that no final settlement between the Owner and the Contractor shall abridge the right of any beneficiary hereunder, whose claim may be unsatisfied.

IN WITNESS WHEREOF, this instrument is executed in 6 counterparts, each one of which shall be deemed an original, this the _____ day of _____, 20____.

WITNESSES:

Principal

BY: _____

Address

(SEAL)

WITNESSES:

Surety

BY: _____

Attorney-in-Fact

NOTE: Surety companies executing bonds must appear on the Treasury Department's most current list (Circular 570 as amended) and be authorized to transact business in the state where the project is located.
