

2007 WATER SYSTEM IMPROVEMENTS

# MONROE COUNTY WATER DISTRICT

## CONTRACT IIIB - PHASE IX - ELEVATED WATER STORAGE TANK

MARK WILLIAMS - CHAIRMAN

JOHN THOMPSON - SECRETARY

DR. KENNETH CRABTREE - COMMISSIONER

MIKE EMBERTON - COMMISSIONER

JOHNNY MILLER - COMMISSIONER

RICK ROSS - MANAGER

***STIGALL ENGINEERING ASSOCIATES, INC.***  
***CONSULTING ENGINEERS***

**4117 HILLSBORO PIKE - SUITE 206**  
**NASHVILLE, TENNESSEE 37215**

**MAY 2008**



PROJECT NO. 0323

**REVISED : JULY 2015**



**GENERAL NOTES:**

1. CONTRACTOR TO FIELD LOCATE & VERIFY ALL EXISTING UTILITIES PRIOR TO BEGINNING CONSTRUCTION.
2. ALL LINES SHOWN CROSSING PAVED SURFACES SHALL BE PUNCHED UNDER, UNLESS NOTED OTHERWISE.
3. ALL LINES SHOWN CROSSING GRAVELED AREAS CAN BE OPEN CUT.

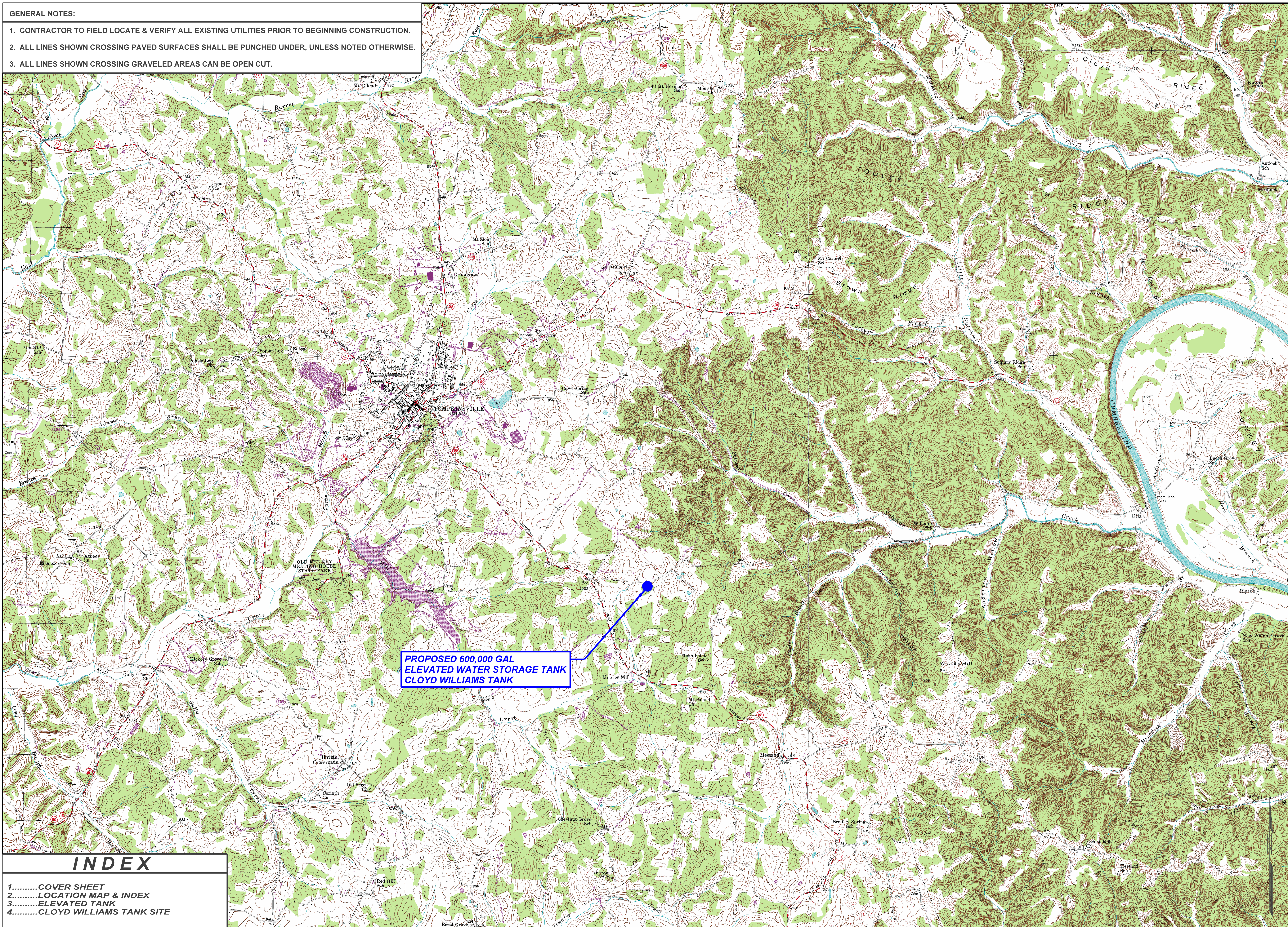

**STIGALL ENGINEERING ASSOCIATES, INC.**  
 111 HARRISON AVE., SUITE 200  
 NASHVILLE, TENNESSEE 37219  
 TELEPHONE : (615) 462-7515  
 FACSIMILE : (615) 462-7517

| NO. | DESCRIPTION | DATE | BY |
|-----|-------------|------|----|
|     |             |      |    |
|     |             |      |    |
|     |             |      |    |
|     |             |      |    |
|     |             |      |    |

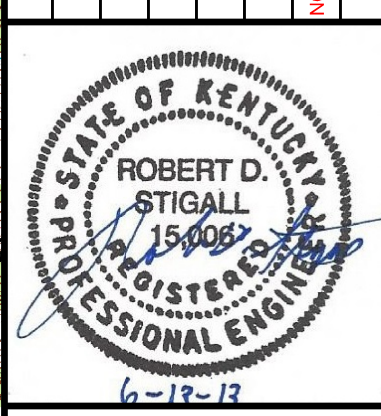

**2007 WATER SYSTEM IMPROVEMENTS  
 MONROE COUNTY WATER DISTRICT  
 CONTRACT IIB-PHASE IX-WATER STORAGE TANKS  
 LOCATION MAP & INDEX**

|                 |               |
|-----------------|---------------|
| DESIGNED:       | RDS           |
| DRAWN:          | RLP           |
| CHECKED:        | RDS           |
| APPROVED:       | RDS           |
| DATE:           | JULY 2015     |
| SCALE:          | 1" = 2000'    |
| SHEET NO.       | <b>2 of 4</b> |
| SEA PROJECT NO. | 0323          |

**INDEX**

- 1.....COVER SHEET
- 2.....LOCATION MAP & INDEX
- 3.....ELEVATED TANK
- 4.....CLOYD WILLIAMS TANK SITE



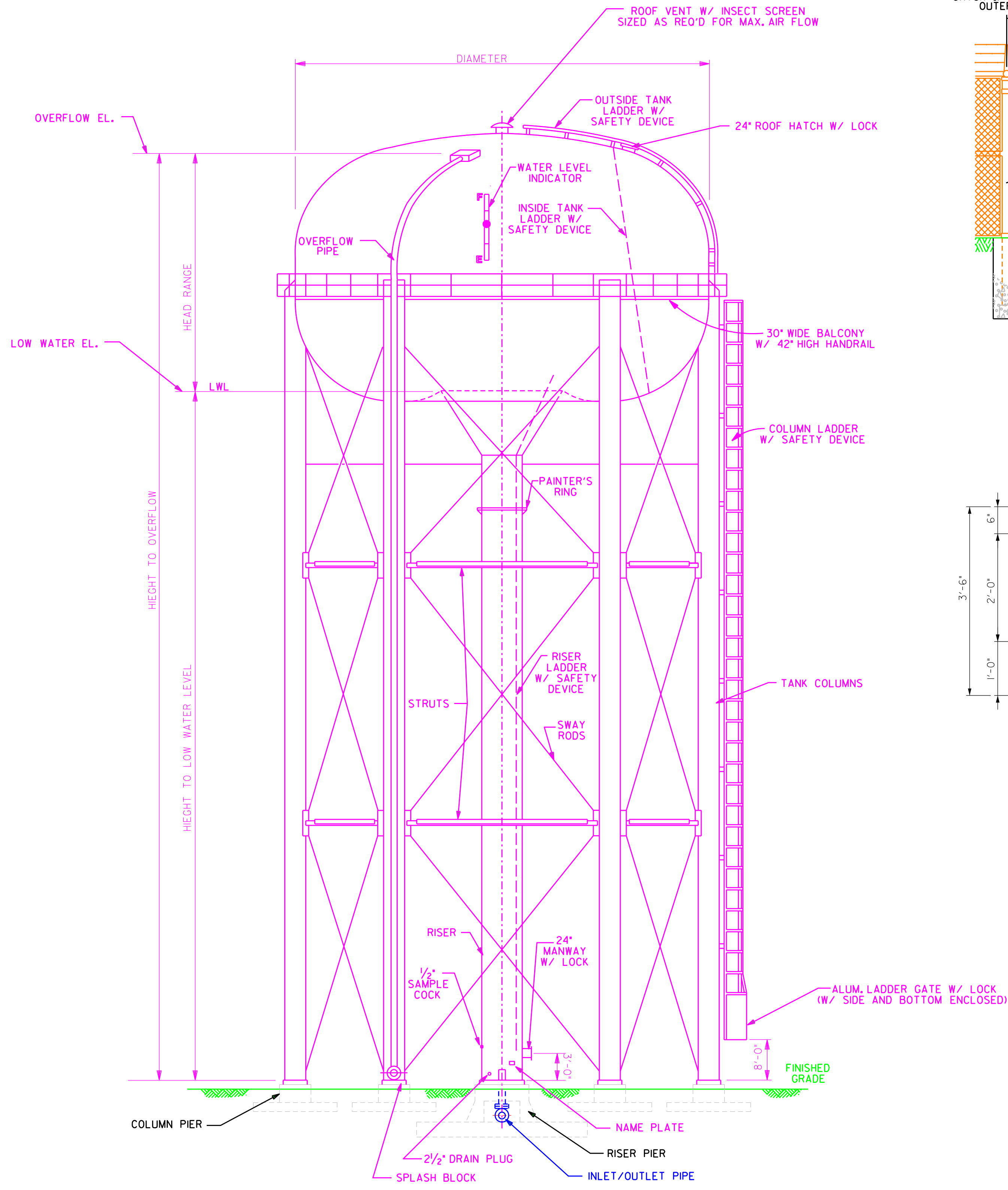

**ELEVATED TANK ELEVATION**  
NO SCALE

| TANK DATA                 |                |
|---------------------------|----------------|
|                           | CLOYD WILLIAMS |
| SIZE OF TANK (GALLONS)    | 600,000        |
| OVERFLOW ELEVATION        | 1119.00        |
| LOW WATER ELEVATION (LWL) | 1082.50        |
| TOP OF PIER ELEVATION     | 999.00         |
| HEIGHT TO OVERFLOW        | 120'-0"        |
| HEIGHT TO LOW WATER LEVEL | 83'-6"         |
| DIAMETER                  | 56'-0"         |
| HEAD RANGE                | 36'-6"         |
| OVERFLOW PIPE SIZE        | 8"             |
| ROOF VENT SIZED FOR       | PER MFG.       |
| SEISMIC ZONE              | PER SPECS      |
| SNOW LOAD                 | PER SPECS      |
| WIND LOAD                 | PER SPECS      |
| INLET/OUTLET PIPE SLEEVE  | 18"            |
| INLET/OUTLET PIPE SIZE    | 16"            |
| FINISHED GRADE ELEVATION  | 998.50         |
| NO. OF COLUMN PIERS       | PER MANUF.     |

**GENERAL NOTES**

- ALL WORK SHALL BE DONE IN ACCORDANCE WITH THE LATEST REVISIONS OF AWWA D-100 AND ALL FEDERAL, STATE & LOCAL CODES.
- THE TANK AND FOUNDATIONS DRAWINGS SUBMITTED BY MANUFACTURER SHALL BE STAMPED BY A LICENCED ENGINEER FROM THE STATE IN WHICH THE TANK IS TO BE BUILT.
- THE FOUNDATION SHALL BE DESIGNED PER THE SOIL BEARING REPORT PREPARED BY CONTRACTOR (SEE SPEC.)
- ALL LOCKS FOR FENCE GATE, LADDER GATES, MANWAYS, ETC. TO BE KEYPED ALIKE.
- THE CONTRACTOR SHALL MEET WITH THE OWNER AND ENGINEER TO PERFORM AN 11th MONTH INSPECTION.

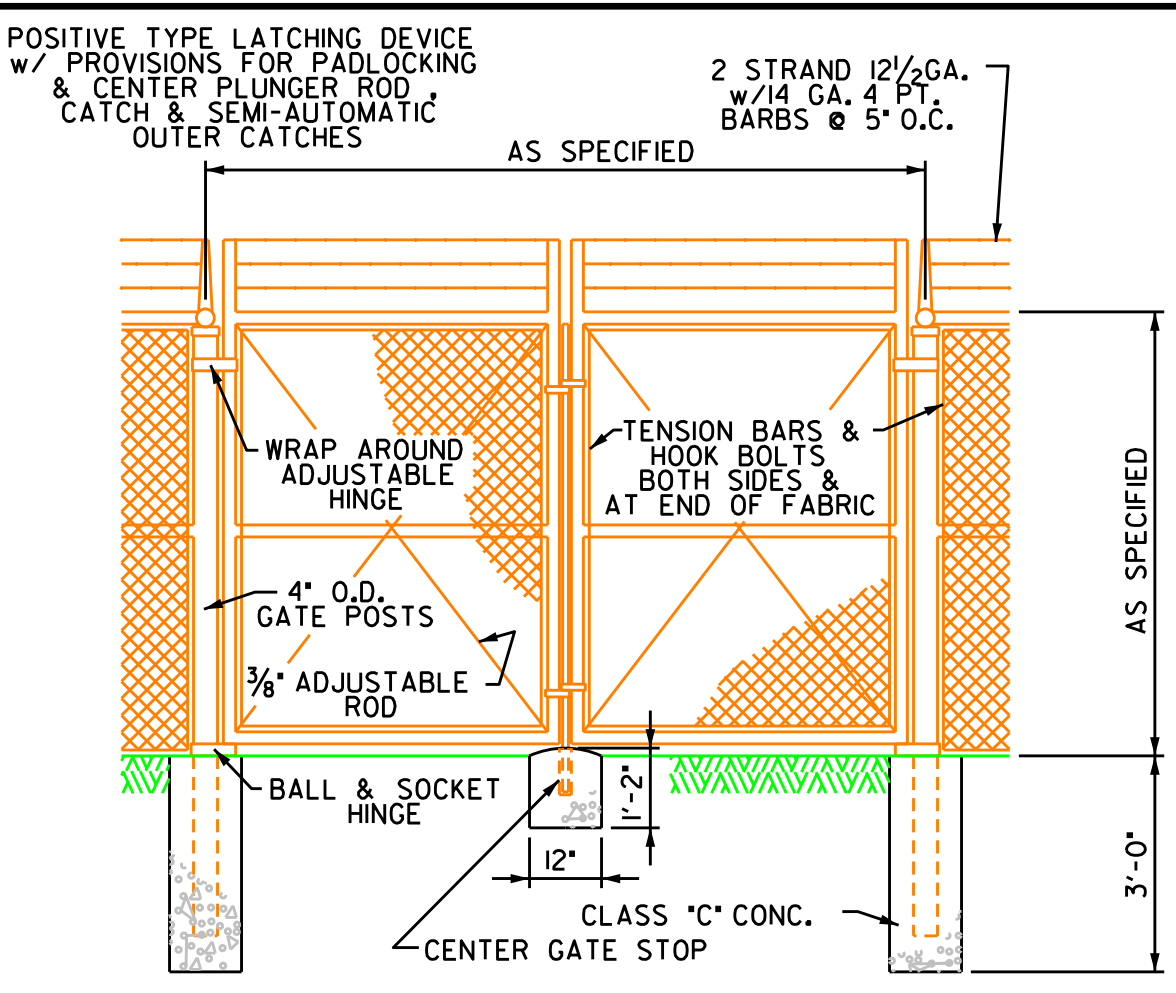

**FENCE GATE DETAIL**  
NO SCALE

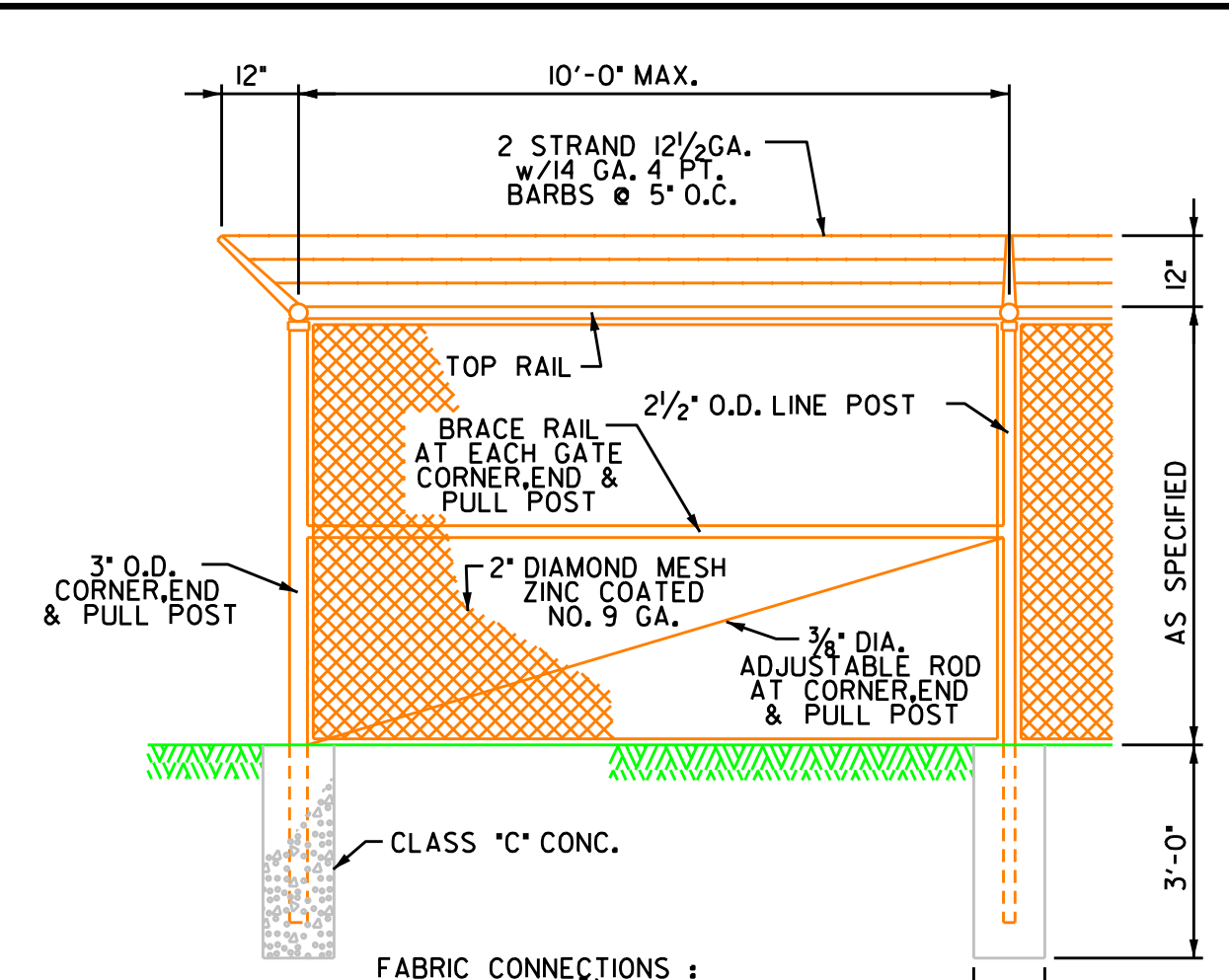

**FENCE DETAIL**  
NO SCALE

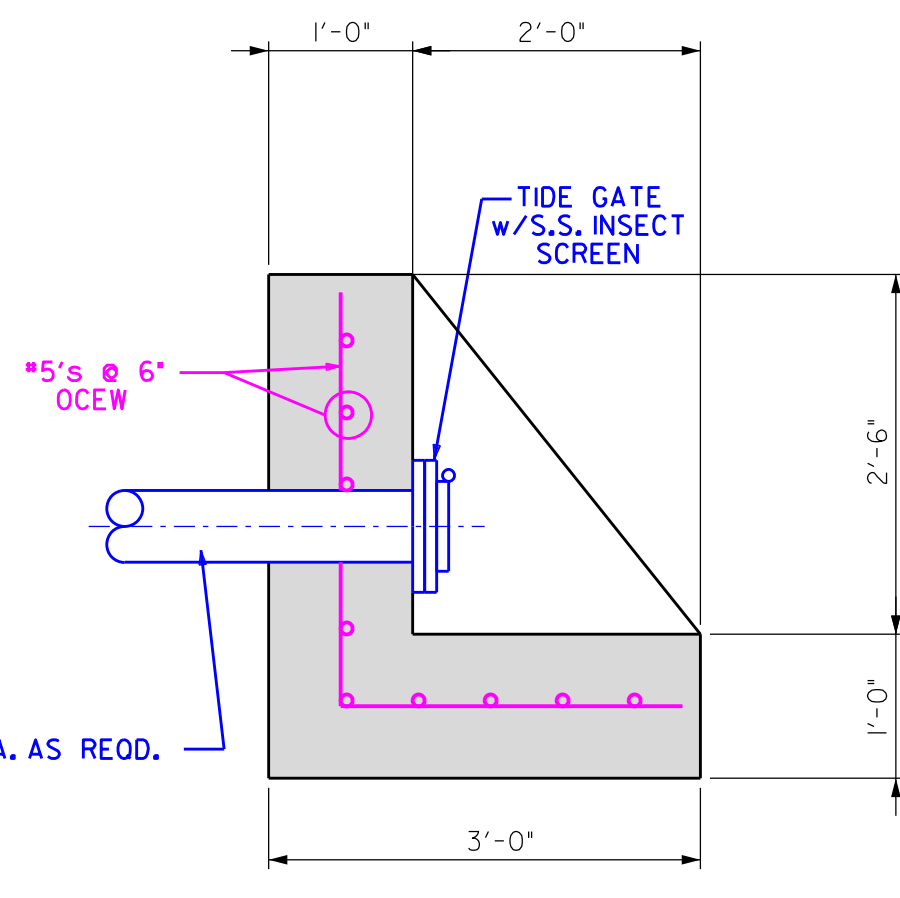
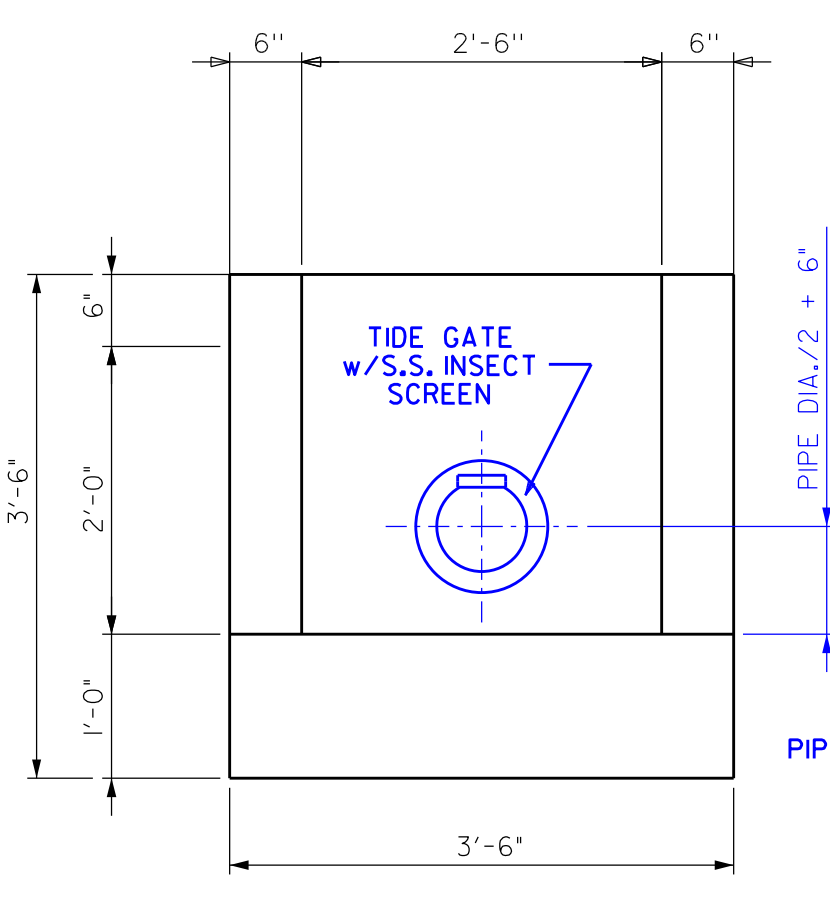

**HEADWALL DETAIL**  
NO SCALE

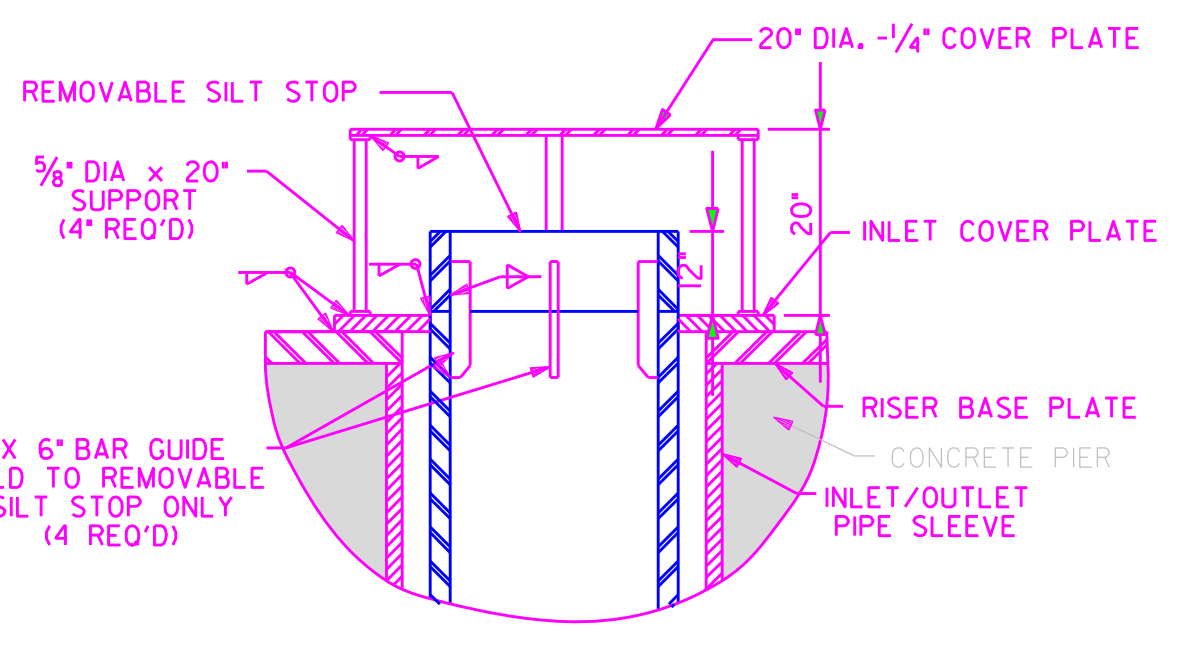

**REMOVABLE SILT STOP - DETAIL**  
NO SCALE

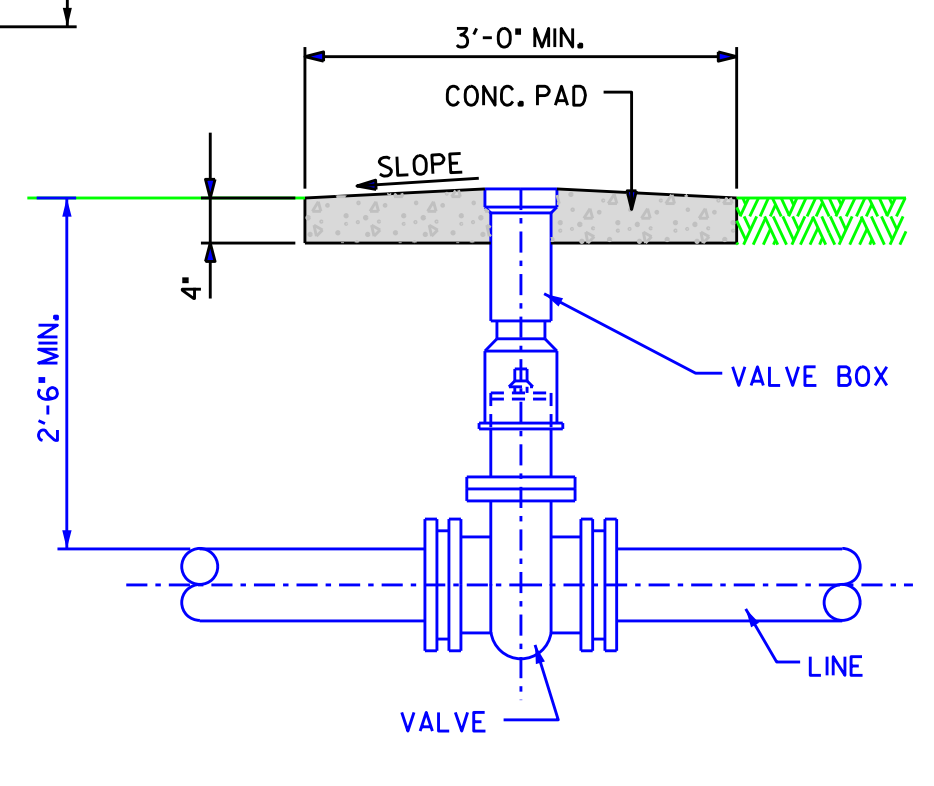

**TYPICAL VALVE SETTING DETAIL**  
NO SCALE

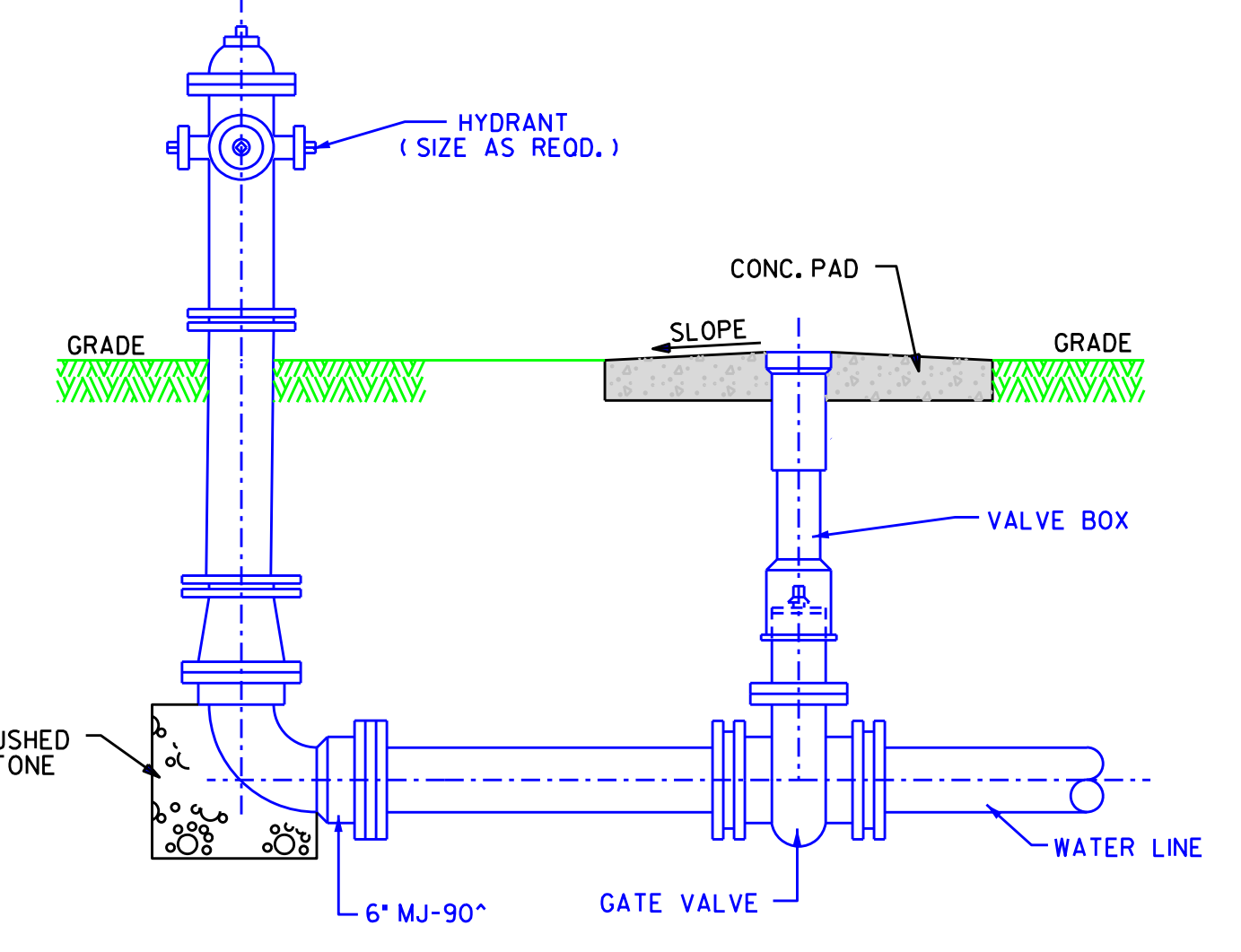

**TYPICAL HYDRANT SETTING DETAIL**  
NO SCALE

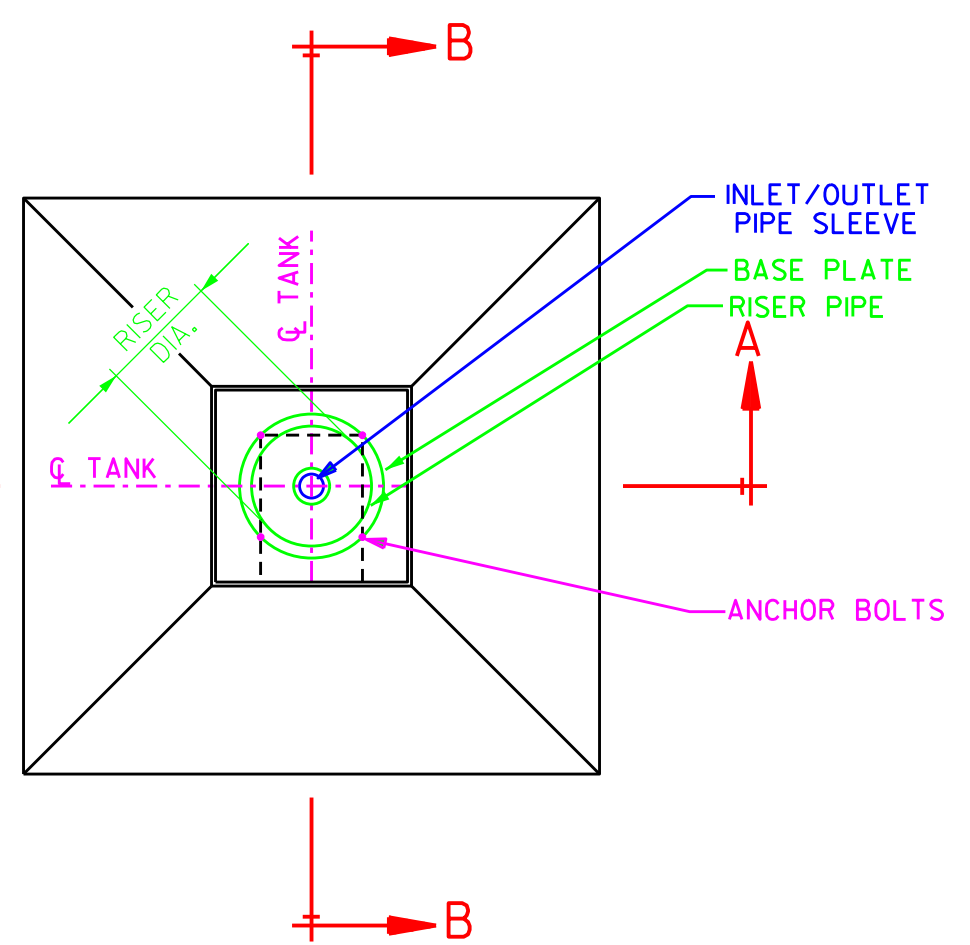

**RISER PIER PLAN**  
NO SCALE

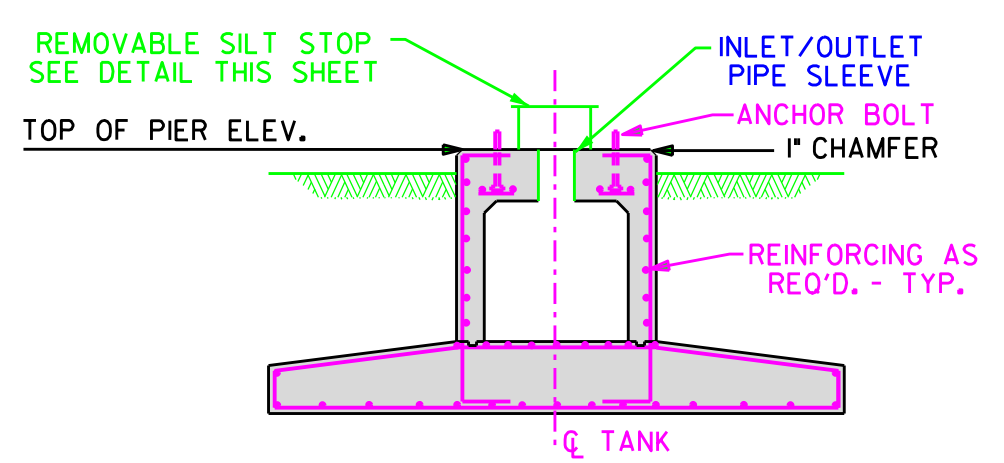

**SECTION A-A**  
NO SCALE

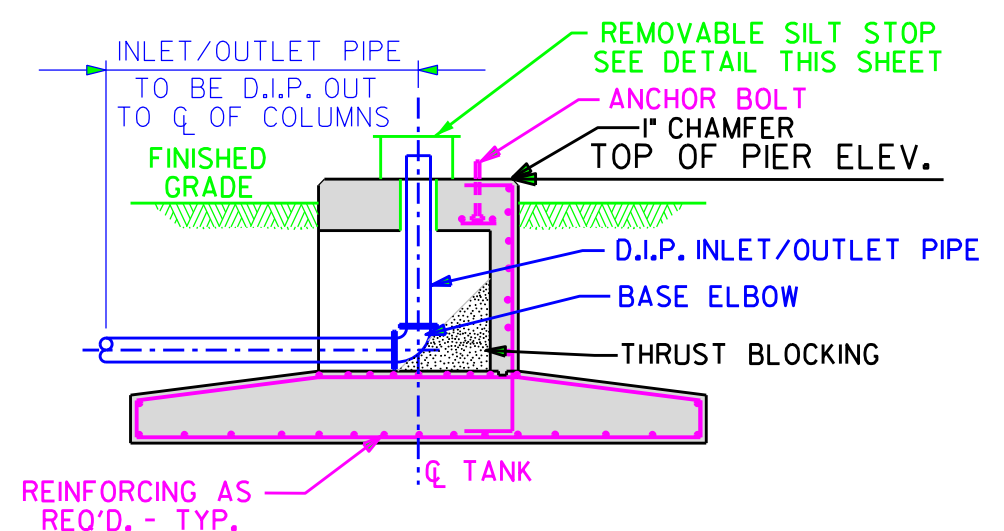

**SECTION B-B**  
NO SCALE

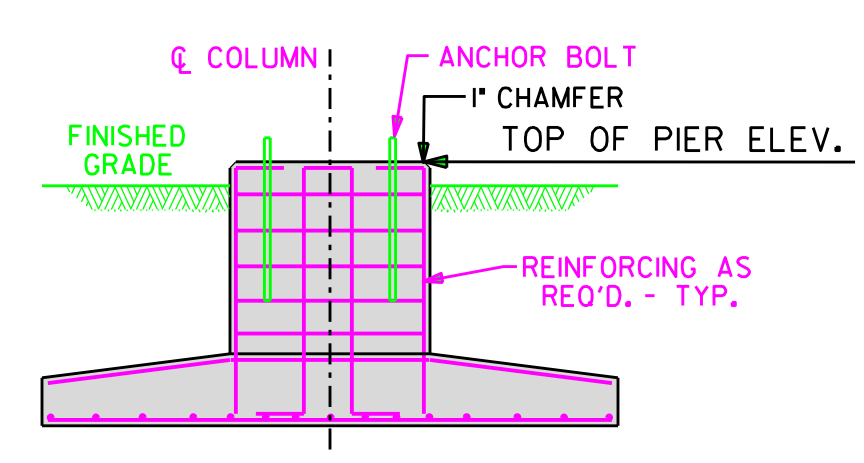

**COLUMN PIER SECTION**  
NO SCALE

| NO. | DESCRIPTION | DATE | BY |
|-----|-------------|------|----|
|     |             |      |    |
|     |             |      |    |
|     |             |      |    |
|     |             |      |    |

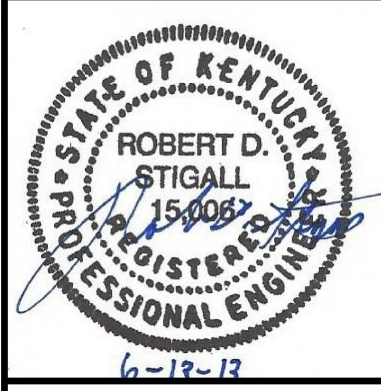

2007 WATER SYSTEM IMPROVEMENTS  
**MONROE COUNTY WATER DISTRICT**  
CONTRACT IIB-PHASE IX-WATER STORAGE TANKS  
**ELEVATED STORAGE TANK**

|                 |               |
|-----------------|---------------|
| DESIGNED        | RDS           |
| DRAWN           | RLP           |
| CHECKED         | RDS           |
| APPROVED        | RDS           |
| DATE:           | JULY 2015     |
| SCALE:          | AS SHOWN      |
| SHEET NO.       | <b>3 of 4</b> |
| SEA PROJECT NO. | 0323          |



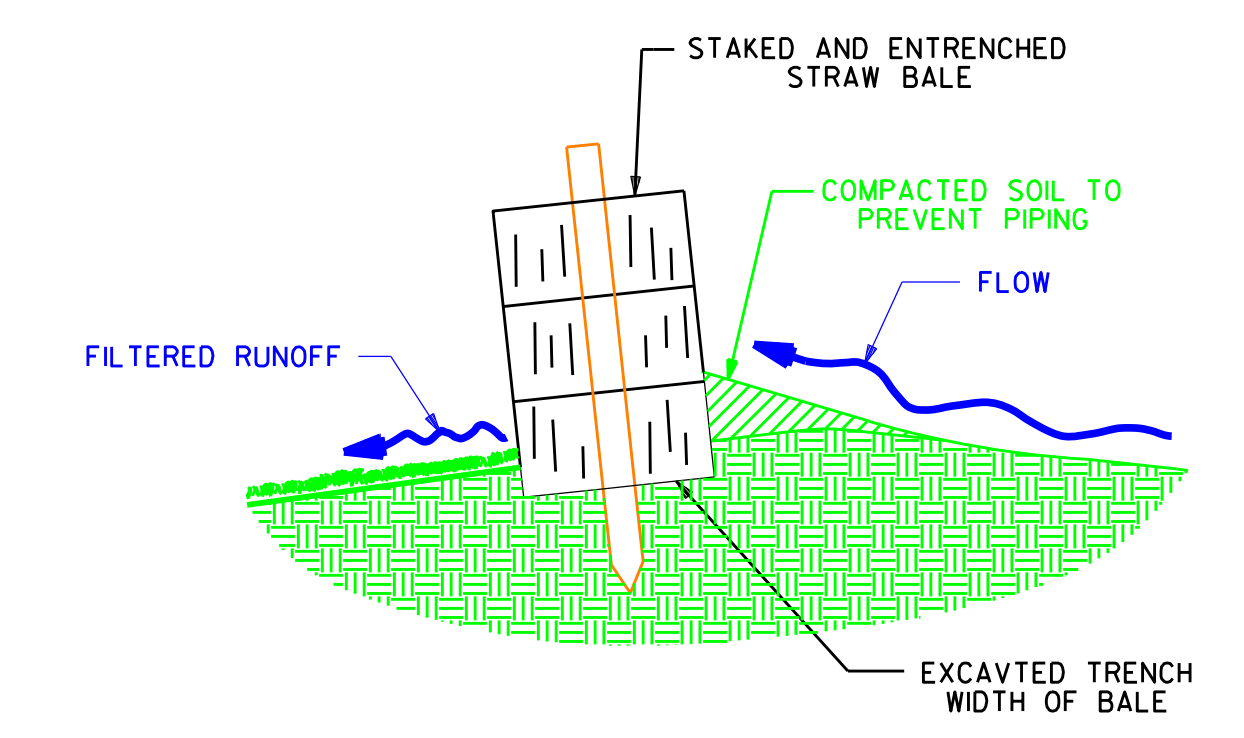
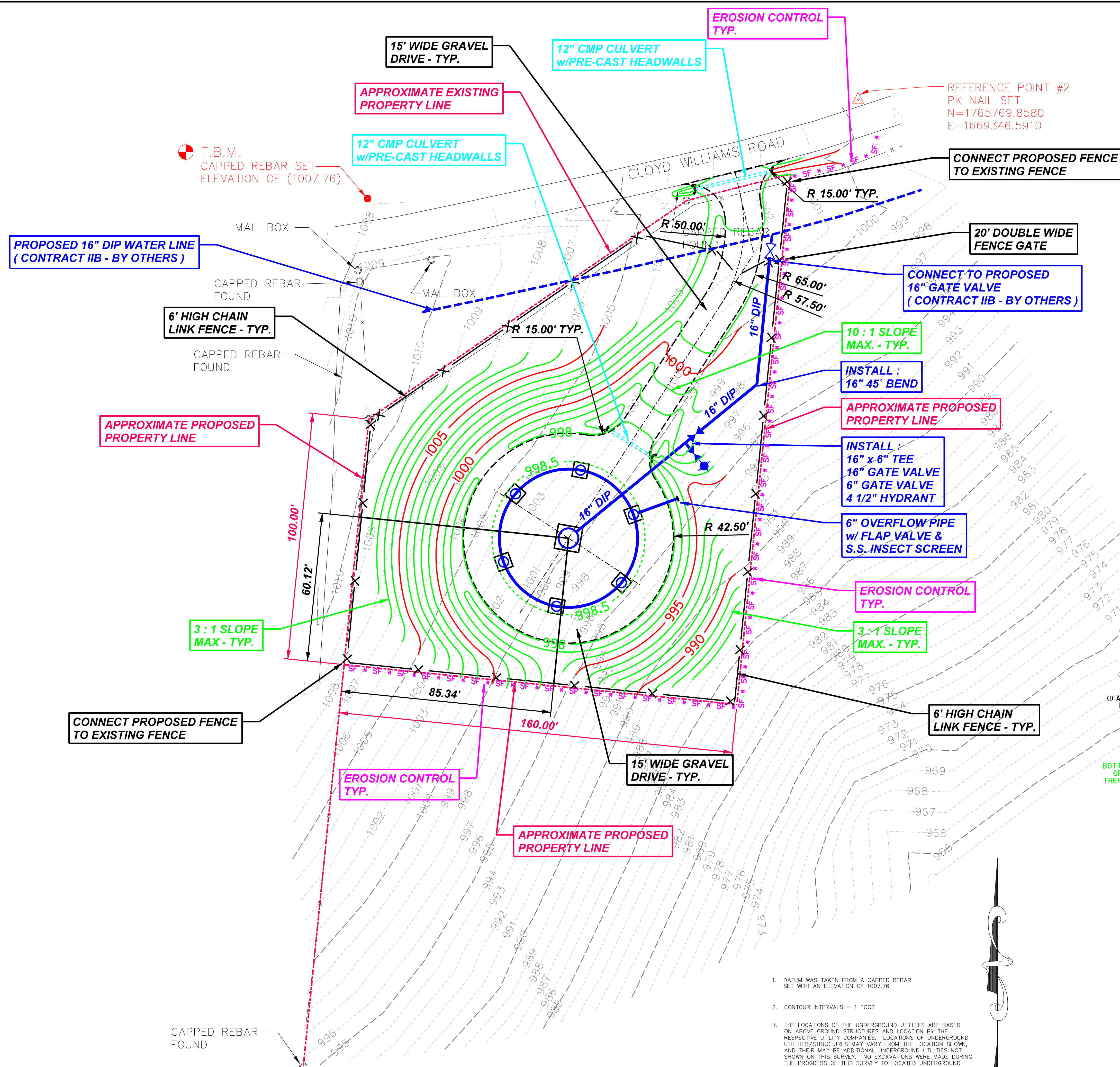

NOTE: WEDGE LOOSE STRAW BETWEEN BALES  
**STRAW BALE BARRIER**  
 SCALE: 1/2" = 1'-0"

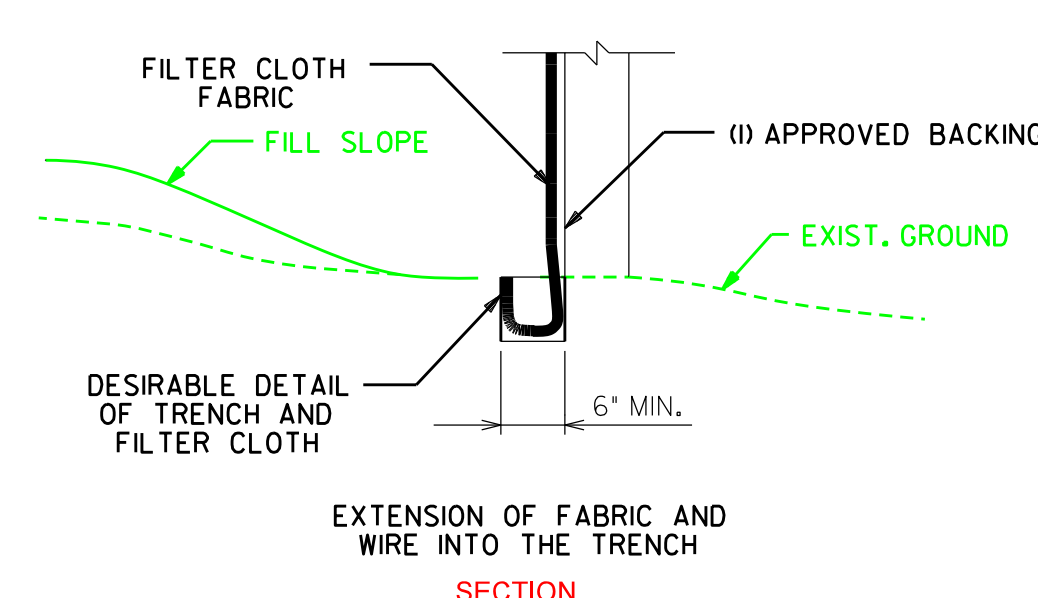
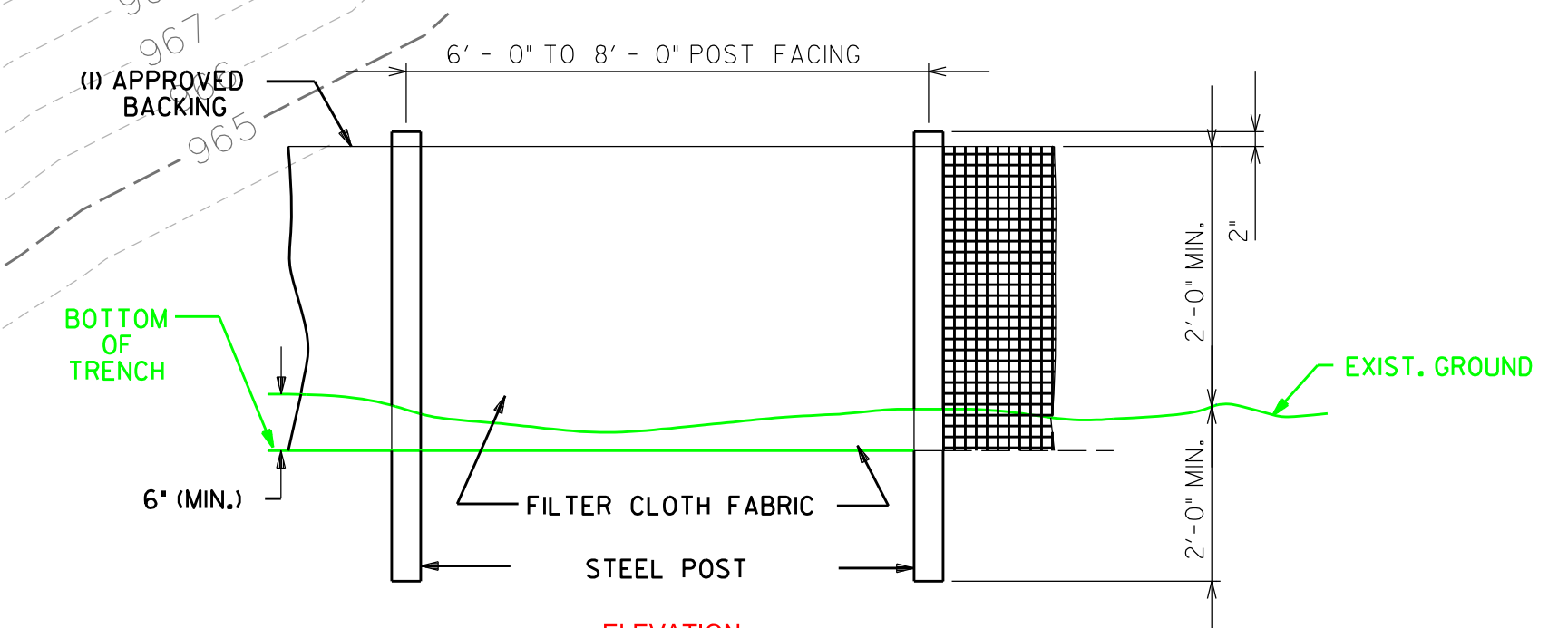

NOTE:  
 1) FILTER CLOTH SHALL MEET THE REQUIREMENTS OF SECTION 209 OF THE STANDARD SPECIFICATIONS. (TDOT)  
 2) A PREASSEMBLED SILT FENCE MEETING THE REQUIREMENTS OF THIS DRAWING IS ACCEPTABLE IN LIEU OF A FIELD CONSTRUCTED SILT FENCE.

**SILT FENCE DETAIL**  
 SCALE: 1/2" = 1'-0"

- DATUM WAS TAKEN FROM A CAPPED REBAR SET WITH AN ELEVATION OF 1007.76
- CONTOUR INTERVALS = 1 FOOT
- THE LOCATIONS OF THE UNDERGROUND UTILITIES ARE BASED ON ABOVE GROUND STRUCTURES AND LOCATION BY THE RESPECTIVE UTILITY COMPANIES. LOCATIONS OF UNDERGROUND UTILITIES/STRUCTURES MAY VARY FROM THE LOCATION SHOWN, AND THERE MAY BE ADDITIONAL UNDERGROUND UTILITIES NOT SHOWN ON THIS SURVEY. NO EXCAVATIONS WERE MADE DURING THE PROGRESS OF THIS SURVEY TO LOCATED UNDERGROUND UTILITIES/STRUCTURES. IT IS THE RESPONSIBILITY OF THE CONTRACTOR TO MAINTAIN THE INTEGRITY OF ALL UNDERGROUND UTILITIES/STRUCTURES.

STIGALL  
 ENGINEERING  
 ASSOCIATES, INC.  
 411 HARRISON AVE., SUITE 206  
 NASHVILLE, TENNESSEE 37219  
 TELEPHONE: (615) 482-7515  
 FACSIMILE: (615) 482-5117

| NO. | DATE | BY | REVISIONS |
|-----|------|----|-----------|
|     |      |    |           |
|     |      |    |           |
|     |      |    |           |
|     |      |    |           |
|     |      |    |           |
|     |      |    |           |
|     |      |    |           |
|     |      |    |           |
|     |      |    |           |
|     |      |    |           |

**2007 WATER SYSTEM IMPROVEMENTS**  
**MONROE COUNTY WATER DISTRICT**  
**CONTRACT IIB-PHASE IX-WATER STORAGE TANKS**  
**CLOYD WILLIAMS TANK**

|                 |               |
|-----------------|---------------|
| DESIGNED:       | RDS           |
| DRAWN:          | RLP           |
| CHECKED:        | RDS           |
| APPROVED:       | RDS           |
| DATE:           | JULY 2015     |
| SCALE:          | 1" = 20'      |
| SHEET NO.       | <b>4 of 4</b> |
| SEA PROJECT NO. | 0323          |