

AFFIDAVIT

STATE OF GEORGIA

COUNTY OF FULTON

BEFORE ME, the undersigned authority, duly commissioned and qualified in and for the State and County aforesaid, personally came and appeared W. Keith Milner, who, being by me first duly sworn deposed and said that:

He is appearing as a witness before the Kentucky Public Service Commission in Case No. 2003-00379, Review of Federal Communications Commission's Triennial Review Order Regarding Unbundling Requirements for Individual Network Elements, and if present before the Commission and duly sworn, his testimony would be set forth in the annexed testimony consisting of 10 pages and 5 exhibits.

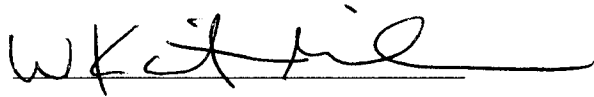

W. Keith Milner

SWORN TO AND SUBSCRIBED BEFORE ME
THIS 9th DAY OF FEBRUARY, 2004

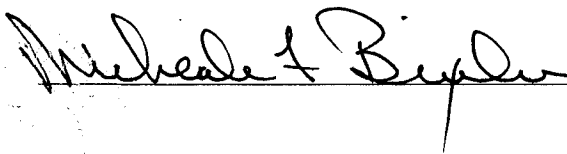
 Notary Public

MICHEALE F. BIXLER
Notary Public, Douglas County, Georgia
My Commission Expires November 3, 2005

1 BELL SOUTH TELECOMMUNICATIONS, INC.
2 DIRECT TESTIMONY OF W. KEITH MILNER
3 BEFORE THE KENTUCKY PUBLIC SERVICE COMMISSION
4 DOCKET NO. 2003-00379
5 FEBRUARY 11, 2004
6

7 Q. PLEASE STATE YOUR NAME, YOUR BUSINESS ADDRESS, AND YOUR
8 POSITION WITH BELL SOUTH TELECOMMUNICATIONS, INC.
9 ("BELL SOUTH").
10

11 A. My name is W. Keith Milner. My business address is 675 West Peachtree Street,
12 Atlanta, Georgia 30375. I am Assistant Vice President - Interconnection
13 Operations for BellSouth. I have served in my present role since February 1996.
14

15 Q. PLEASE SUMMARIZE YOUR BACKGROUND AND EXPERIENCE.
16

17 A. My career in the telecommunications industry spans over 33 years and includes
18 responsibilities in the areas of network planning, engineering, training,
19 administration, and operations. I have held positions of responsibility with a local
20 exchange telephone company, a long distance company, and a research and
21 development company. I have extensive experience in all phases of
22 telecommunications network planning, deployment, and operations in both the
23 domestic and international arenas.
24

25 I graduated from Fayetteville Technical Institute in Fayetteville, North Carolina, in

1 1970, with an Associate of Applied Science in Business Administration degree. I
2 graduated from Georgia State University in 1992 with a Master of Business
3 Administration degree.
4

5 Q. HAVE YOU TESTIFIED PREVIOUSLY BEFORE ANY STATE PUBLIC
6 SERVICE COMMISSION, AND IF SO, BRIEFLY DESCRIBE THE SUBJECT OF
7 YOUR TESTIMONY?
8

9 A. Yes, I have testified before the state Public Service Commissions in Alabama,
10 Florida, Georgia, Kentucky, Louisiana, Mississippi, and South Carolina, the
11 Tennessee Regulatory Authority, and the North Carolina Utilities Commission on
12 the technical capabilities of the switching and facilities network, introduction of
13 new service offerings, expanded calling areas, unbundling, and network
14 interconnection.
15

16 Q. WHAT IS THE PURPOSE OF YOUR TESTIMONY?
17

18 A. I describe and support the engineering and network architecture assumptions
19 that form the foundation for BellSouth's Analysis of Competitive Entry ("BACE")
20 Model. I will also discuss how an efficient provider of local telecommunications
21 service entering the market as a facilities-based provider would likely develop
22 and grow its network in order to serve mass-market customers.
23

24 Q. GENERALLY, PLEASE DESCRIBE THE BASIS FOR BELL SOUTH'S
25 ENGINEERING AND NETWORK ASSUMPTIONS USED IN THE BACE

1 MODEL.

2
3 A. Typically, a Competitive Local Exchange Carrier ("CLEC") deploys a switch to
4 serve a large area (often an entire state), and provides local service to its
5 customers in that area by interconnecting with the incumbent local exchange
6 carrier's ("ILEC's") network at an ILEC tandem.

7
8 There are three (3) basic network constructs from which an efficient provider
9 entering the telecommunications market would likely choose. Each of these
10 three options can be modeled in BellSouth's BACE Model. Exhibit WKM-1,
11 attached to my testimony, illustrates these three (3) network options. Each of
12 these network options assumes that a CLEC places a switch to serve local
13 customers within a Local Access Transport Area ("LATA"), although, as I said
14 earlier, it is not unusual for a CLEC to use one switch to serve an entire state.
15 Because the BACE Model assumes that a CLEC places a switch in each LATA in
16 which it serves local customers, the results are significantly more conservative
17 than if BellSouth had assumed a CLEC would have only one (1) switch per state.

18
19 Q. WHAT IS THE RELATIONSHIP BETWEEN CLEC SWITCHING INVESTMENTS
20 AND TRANSPORT/TRUNKING COSTS?

21
22 A. There is an economic tradeoff between the quantity of switches serving a given
23 geography versus the length and accompanying costs of loops or interoffice
24 transport. An efficient facilities-based CLEC entering the local
25 telecommunications market often finds that it is less expensive to use one (1)

1 switch to serve a large area, even though this network construct results in the
2 CLEC needing to purchase, lease, construct or otherwise obtain transport
3 facilities to carry traffic from its centralized switch to the various central office
4 locations where the CLEC would be able to connect to loops serving its end user
5 customers. Transport facilities are most often built using fiber optic cables and
6 result in high-capacity transmission systems. Thus, the cost of back-hauling
7 traffic is typically less than the cost of placing an additional switch.

8
9 Q. PLEASE DESCRIBE THE NETWORK CONSTRUCT SHOWN ON PAGE 1 OF
10 EXHIBIT WKM-1 (Option 1).

11
12 A. Option 1, shown on page 1 of Exhibit WKM-1, reflects a configuration wherein a
13 CLEC serves an entire LATA with one (1) switch. The CLEC uses Enhanced
14 Extended Links ("EELs"), which are combinations of local loops and interoffice
15 transport, and are used by the CLEC to carry all traffic to the CLEC's collocation
16 space, typically located at the BellSouth tandem location. At the central office
17 where the CLEC has obtained collocation, the CLEC acquires EELs (for the end
18 users served in central offices other than the central office housing the
19 collocation arrangement) and unbundled loops (for the end users served from
20 that central office). Once the loops are attached to the CLEC's switch, calls
21 originated by the customers served by those loops are handled entirely by the
22 CLEC's switch (for example, calls from one of the CLEC's customers to another
23 of the CLEC's customers) or are handled by the CLEC's switch conveying the
24 call using its interconnection facilities between the CLEC switch and BellSouth's
25 switch (for example, calls from the CLEC's customers to other local service

1 provider's customers).

2

3 Q. PLEASE DESCRIBE THE NETWORK CONSTRUCT SHOWN ON PAGE 2 OF
4 EXHIBIT WKM-1 (Option 2).

5

6 A. Option 2, shown on page 2 of Exhibit WKM-1, also reflects a configuration
7 wherein a CLEC serves an entire LATA with one switch. In this configuration,
8 however, it is assumed that the CLEC chooses to have collocation space in each
9 BellSouth end office from which the CLEC needs access to its end user's local
10 loop on an unbundled basis. By choosing this configuration, the CLEC also gives
11 itself access to more loops composed entirely of copper facilities, thus enlarging
12 its Digital Subscriber Line ("DSL") footprint without collocating Digital Subscriber
13 Line Access Multiplexers ("DSLAMs") or other equipment at Remote Terminal
14 ("RT") sites. The BACE Model can also be run choosing this network
15 configuration.

16

17 Q. PLEASE DESCRIBE THE NETWORK CONSTRUCT SHOWN ON PAGE 3 OF
18 EXHIBIT WKM-1 (Option 3).

19

20 A. As with the two (2) configurations I just described, Option 3 shown on page 3 of
21 Exhibit WKM-1 reflects a configuration wherein a CLEC serves an entire LATA
22 with one (1) switch. In this third configuration, however, the assumption is that
23 there will be some situations wherein a CLEC will choose to have collocation
24 arrangements in certain BellSouth end offices, and there will also be some
25 situations wherein the CLEC will choose to use EELs in lieu of collocation. The

1 BACE Model can be run choosing this option, and the model will calculate and
2 choose the more economical configuration for each portion of the CLEC's
3 network. This network configuration is used in the base case that BellSouth filed
4 with Dr. Aron's testimony. As with Option 2, the more end offices in which a
5 CLEC collocates, the greater the access to so-called "all copper" loops and thus
6 the larger a DSL footprint the CLEC can enjoy without collocation of equipment at
7 RT sites. As I stated earlier, the BACE Model can be run choosing this network
8 configuration.

9
10 Q. FOR THOSE SITUATIONS WHERE COLLOCATION IS ASSUMED IN THE
11 BACE MODEL, PLEASE DESCRIBE THE COLLOCATION ARRANGEMENT
12 USED.

13
14 A. Exhibit WKM-2 illustrates a collocation arrangement used in the BACE Model
15 wherein the CLEC collocates within a BellSouth central office. The assumption
16 for this Option is that the CLEC will acquire unbundled two-wire loops and
17 unbundled DS-1 loops. The CLEC acquires unbundled loops and other
18 unbundled network elements, which BellSouth delivers to the collocation
19 arrangement. BellSouth connects the requested unbundled network element (an
20 unbundled loop, for example) to the CLEC's Connecting Facility Assignment
21 ("CFA"), which conveys the requested UNE to the collocation arrangement. The
22 CFA is typically a CLEC-provided tie cable that extends from that CLEC's
23 collocation arrangement to the collocation demarcation point (typically a
24 connector block on a distributing frame). At the CLEC end of the CFA, the
25 requested unbundled network element is often terminated to a Point of

1 Termination bay ("POT bay") within the collocation arrangement. If provided, the
2 CLEC owns the POT bay and the other equipment within the collocation
3 arrangement. The CLEC may choose to install within the collocation
4 arrangement Digital Loop Carrier ("DLC") equipment for aggregating and
5 concentrating the individual unbundled loops as well as DSLAM equipment for
6 the CLEC's broadband services. This equipment is then attached to multiplexing
7 ("mux") equipment for connection to DS-1 or higher transmission systems to the
8 CLEC's switch located in its own central office.

9
10 Exhibit WKM-3 reflects a typical collocation arrangement within a BellSouth
11 tandem central office. Different from Option 1 described earlier, if the CLEC
12 collocates within the BellSouth tandem central office, it is assumed that the
13 CLEC will aggregate its EELs and other transport requirements at that location.
14 The CLEC then conveys those EELs and transport facilities to its own central
15 office over DS-1 or higher facilities.

16
17 Q. PLEASE DESCRIBE THE CLEC'S SWITCHING ARRANGEMENT ASSUMED IN
18 THE BACE MODEL.

19
20 A. Exhibit WKM-4 illustrates the CLEC switching arrangement that is used in the
21 BACE Model. Earlier in my testimony, I have discussed how loop facilities, EELS
22 and transport facilities are aggregated and concentrated and are then conveyed
23 to the CLEC's central office and then to the CLEC's switch. This Exhibit shows
24 the call routing (once the loop has been connected to the CLEC's switch and the
25 end user begins making and receiving calls) assuming the CLEC sends traffic

1 originated by its end users via BellSouth's tandem switch for completion.

2 Likewise, this Exhibit shows how a CLEC receives traffic originated by the end
3 users of other Local Exchange Carriers ("LECs") bound for that CLEC's end
4 users. In other words, by interconnecting its switched network at BellSouth's
5 access tandem switch location, the CLEC can send and receive traffic between
6 that CLEC's end users and the end users of all other LECs including BellSouth
7 plus other carriers such as IXCs and wireless service providers.

8
9 Q. WHY DO CLECs ROUTE SOME OR ALL OF THEIR TRAFFIC VIA TANDEM
10 SWITCHES?

11
12 A. CLECs route traffic through tandem switches for most of the same reasons as
13 does BellSouth. Tandem switching systems are used to interconnect end office
14 switches when direct trunk groups are *not* economically justified, or when the
15 network configuration indicates alternate routing *is* economically justified.

16 Tandem switches typically provide these functions:

- 17 • Interconnect end offices
- 18 • Connect to other tandems
- 19 • Provide access to Interexchange Carriers
- 20 • Provide access to operator positions.

21
22 In other words, tandem switching systems perform trunk-to-trunk switching and
23 generally provide two (2) basic network functions — traffic concentration and
24 centralization of services. As traffic concentrators, tandems allow the traffic of
25 groups of end offices to be economically gathered for delivery between the end

1 offices or to distant points. Also, with tandem switches, call recording, LATA-
2 wide access, and operator services functions can be centralized for groups of
3 end offices.

4
5 Q. PLEASE DESCRIBE THE CLEC'S FACILITIES LOCATED AT ITS OWN
6 SWITCHING CENTER.

7
8 A. Exhibit WKM-5 shows the types of equipment within the CLEC's own central
9 office. Aggregated, concentrated loops (including EELs) are conveyed to
10 interface equipment (DSX-1 or DSX-3 panels) then on to the DLC Central Office
11 Terminal ("COT"), in the case of incoming loops or EELs, and then to the switch.
12 Equipment for data services such as Asynchronous Transfer Mode ("ATM")
13 packet switches is also housed here. Inbound and outbound calls are received
14 and sent over transport systems at DS-1 or higher to and from BellSouth's
15 tandem switch. Finally, the CLEC either provides for itself or acquires from other
16 providers ancillary functions such as operator services and access to call-related
17 databases.

18
19 Q. DO YOU HAVE INFORMATION FROM THE CLECS THEMSELVES TO
20 SUPPORT YOUR OPINION THAT CLECS TYPICALLY SERVE A LARGE AREA
21 WITH A LIMITED NUMBER OF SWITCHES, RATHER THAN DUPLICATING
22 BELL SOUTH'S NETWORK?

23
24 A. Yes. I have read the sworn testimony of CLECs' witnesses opining on CLEC
25 network architectural considerations. The CLECs have made it clear that their

1 networks are not configured like BellSouth's, and they are relying on fewer
2 switches and more transport to serve their customers. For example, in Kentucky
3 Docket No. 2000-465, AT&T witness, Gregory Follensbee testified that:

4 "AT&T offers local exchange service in Kentucky via 4ESS switches,
5 which function primarily as long distance switches, and 5ESS switches,
6 which act as adjuncts to the 4ESS switches. *AT&T has the ability to*
7 *connect virtually any qualifying local exchange customer in Kentucky to*
8 *one of these switches through AT&T's dedicated access services."*

9 [*emphasis added*] [Docket Number 2000-465, February 6, 2001, Direct
10 Testimony of Gregory Follensbee, pp. 52-53.]

11
12 Q. DOES THIS CONCLUDE YOUR DIRECT TESTIMONY?

13
14 A. Yes.

Option 1

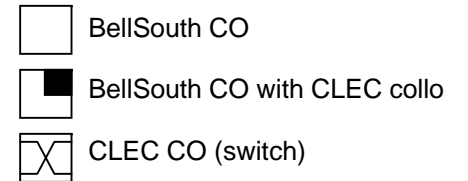
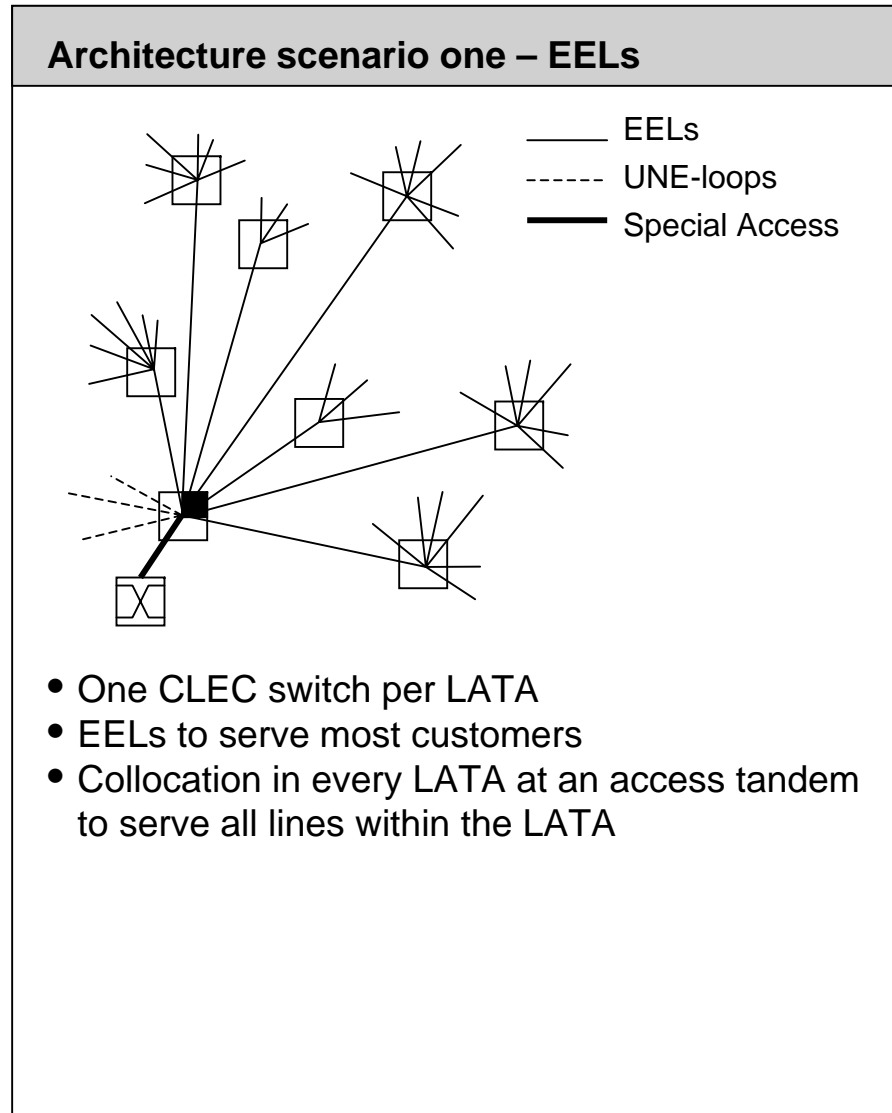

Option 2

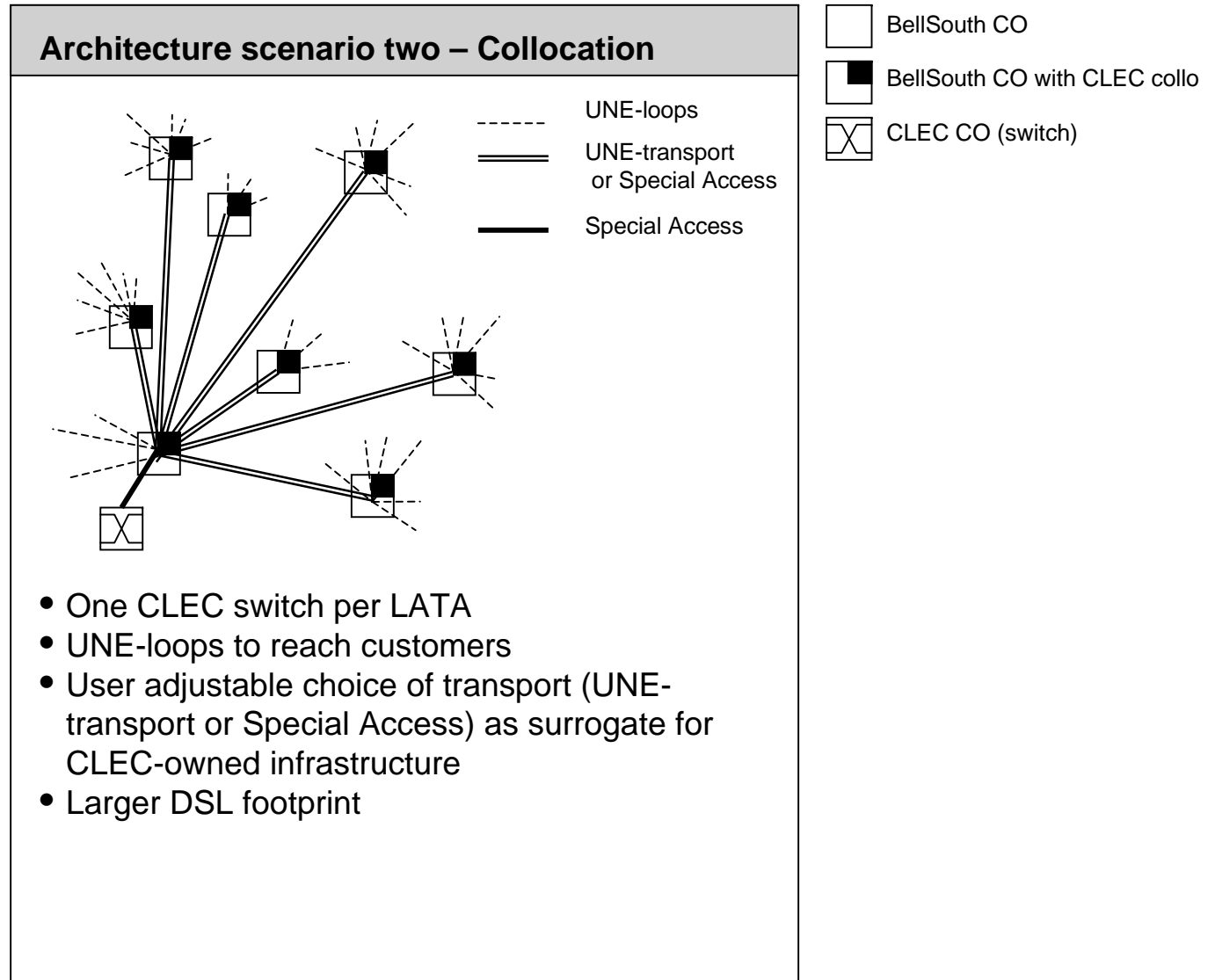

Option 3

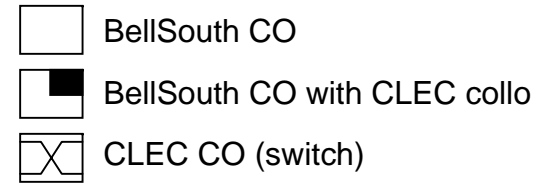
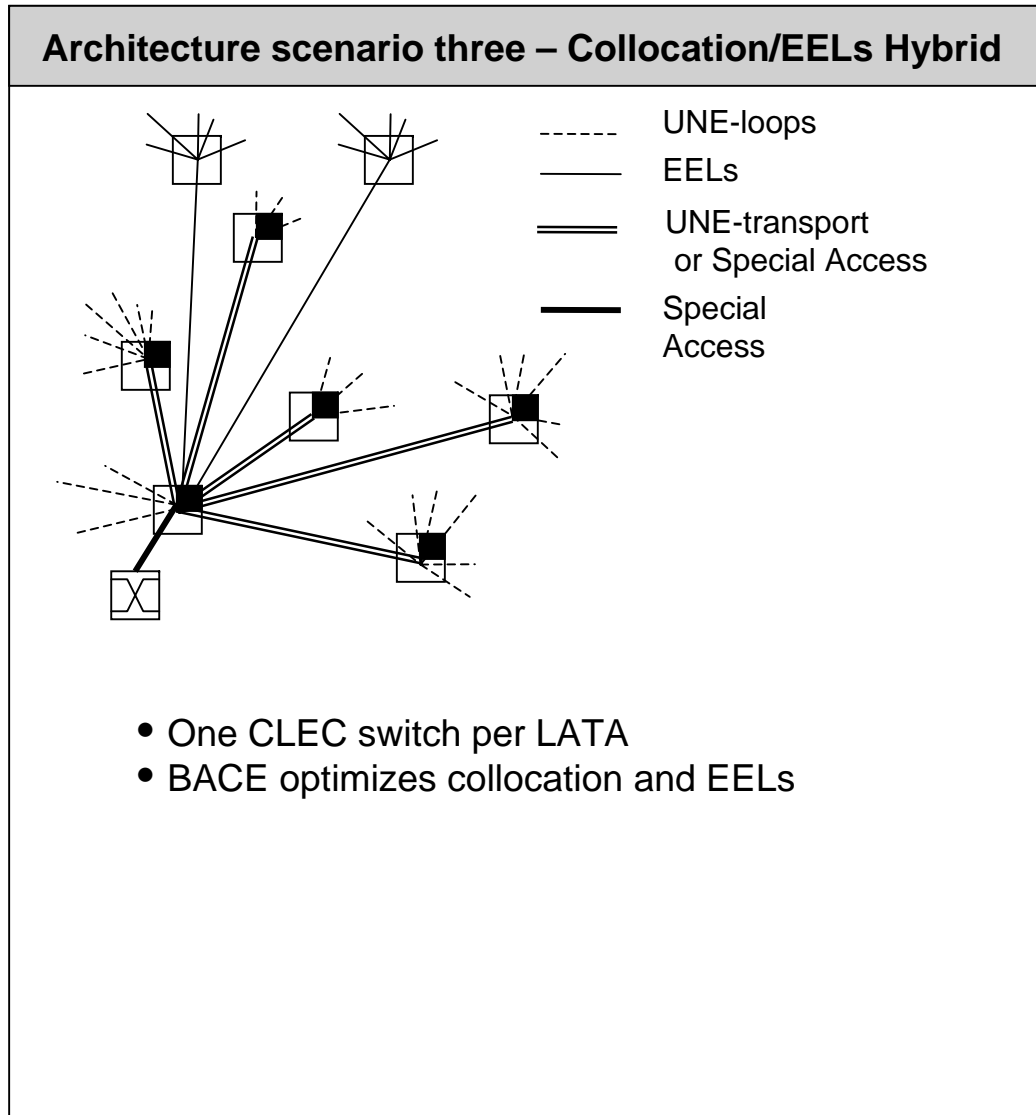

Collocation CLEC Facilities at BellSouth End Office

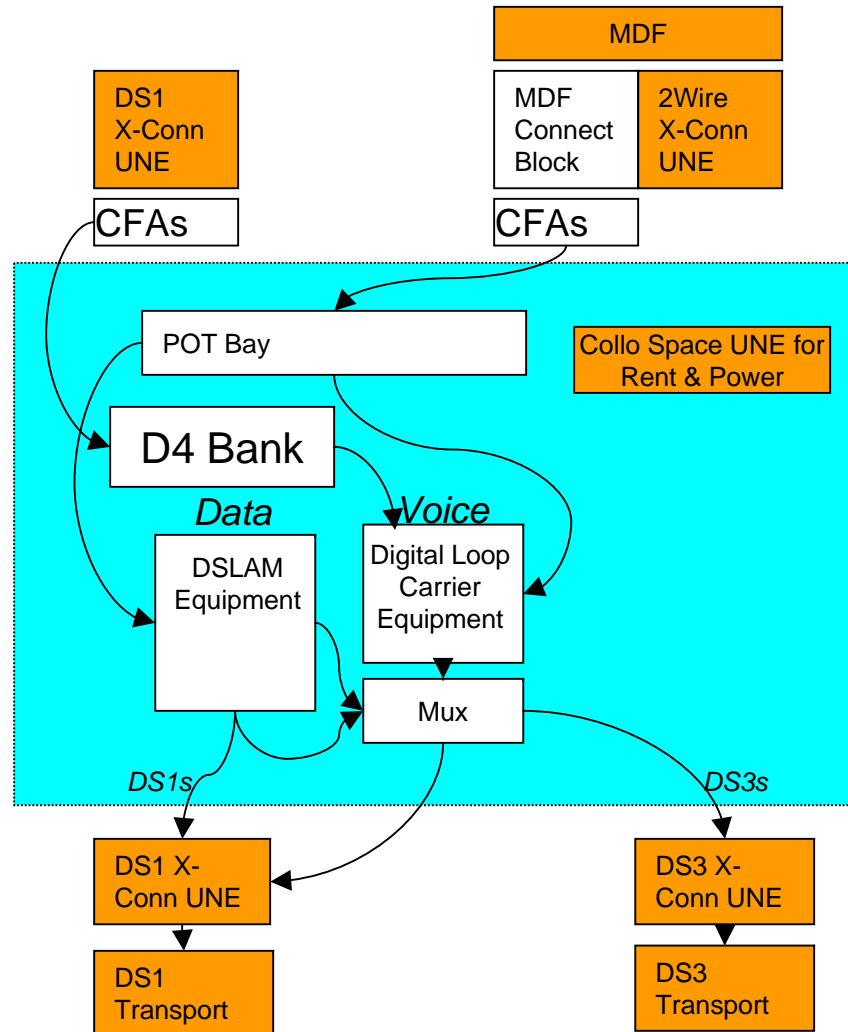

Dark shading indicates BST provided: White indicates CLEC provided, Light Shading is CLEC space

CLEC Facilities Collocated at BellSouth Tandem Switching Central Office

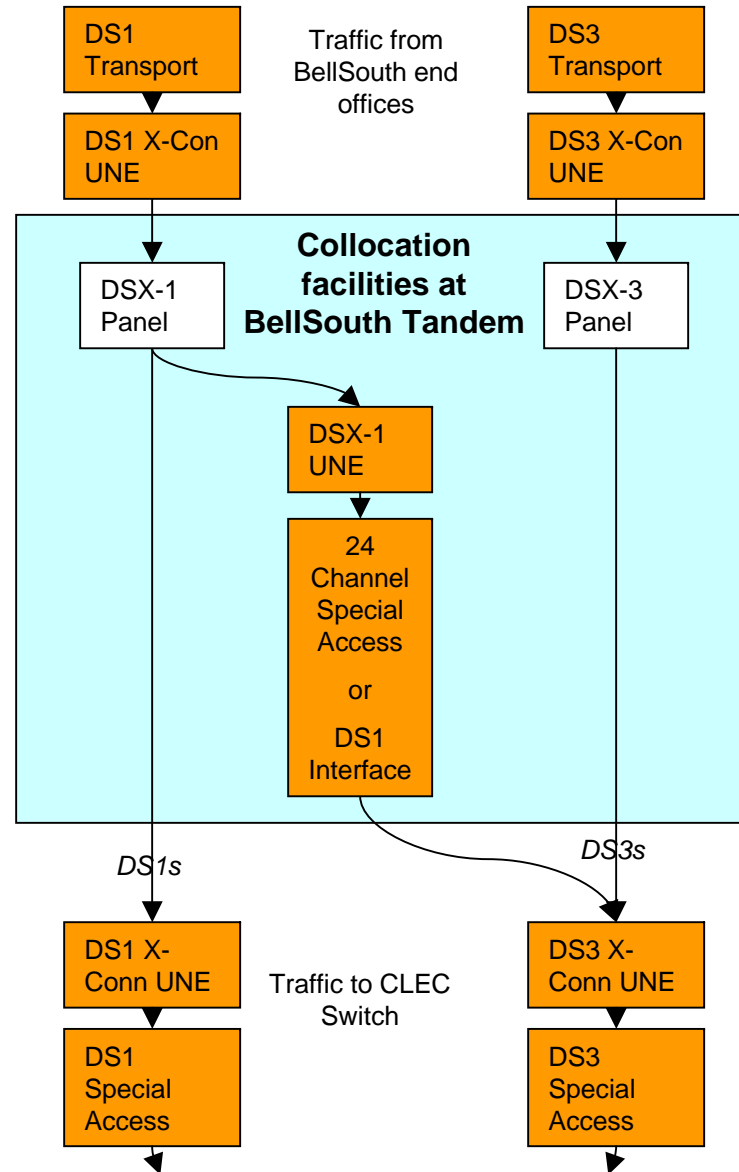

- *Dark Shading* indicates BellSouth provided; *White* indicates CLEC provided, *Light Shading* is CLEC space

Interconnection with other service providers

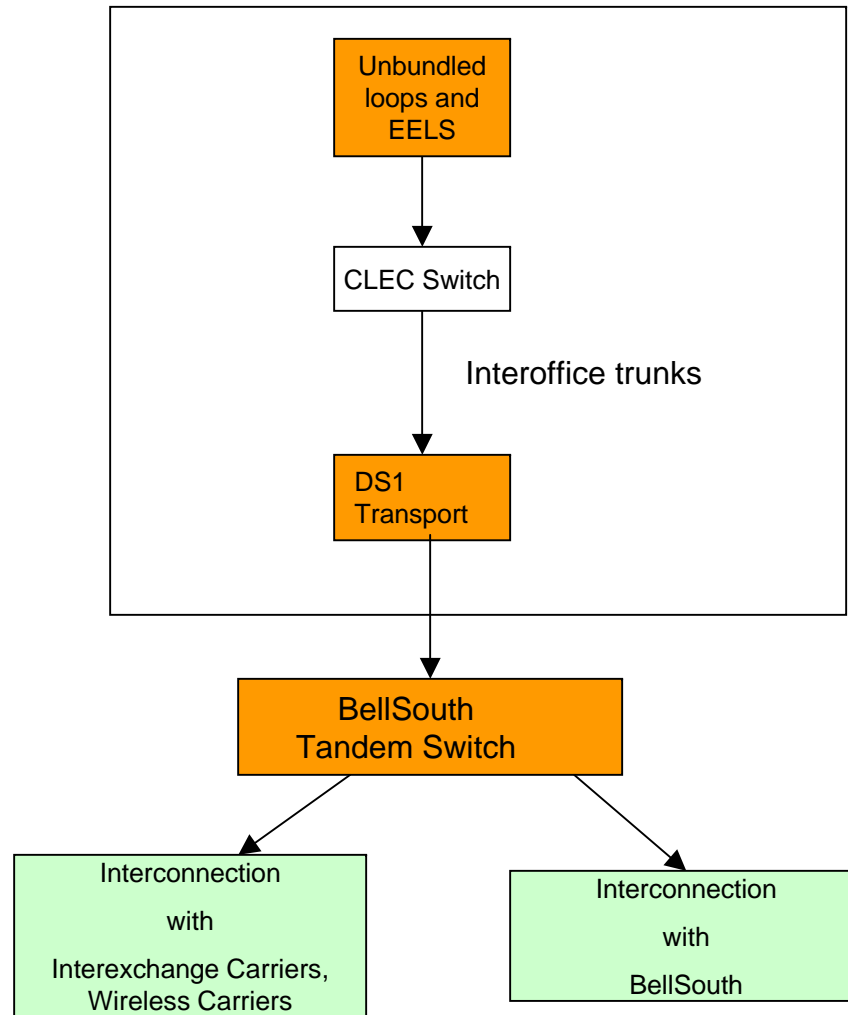

- Dark shading indicates BST provided: White indicates CLEC provided : Medium shading is other entities

NETWORK DESIGN: DESCRIBING CLEC FACILITIES – CLEC Switching Center

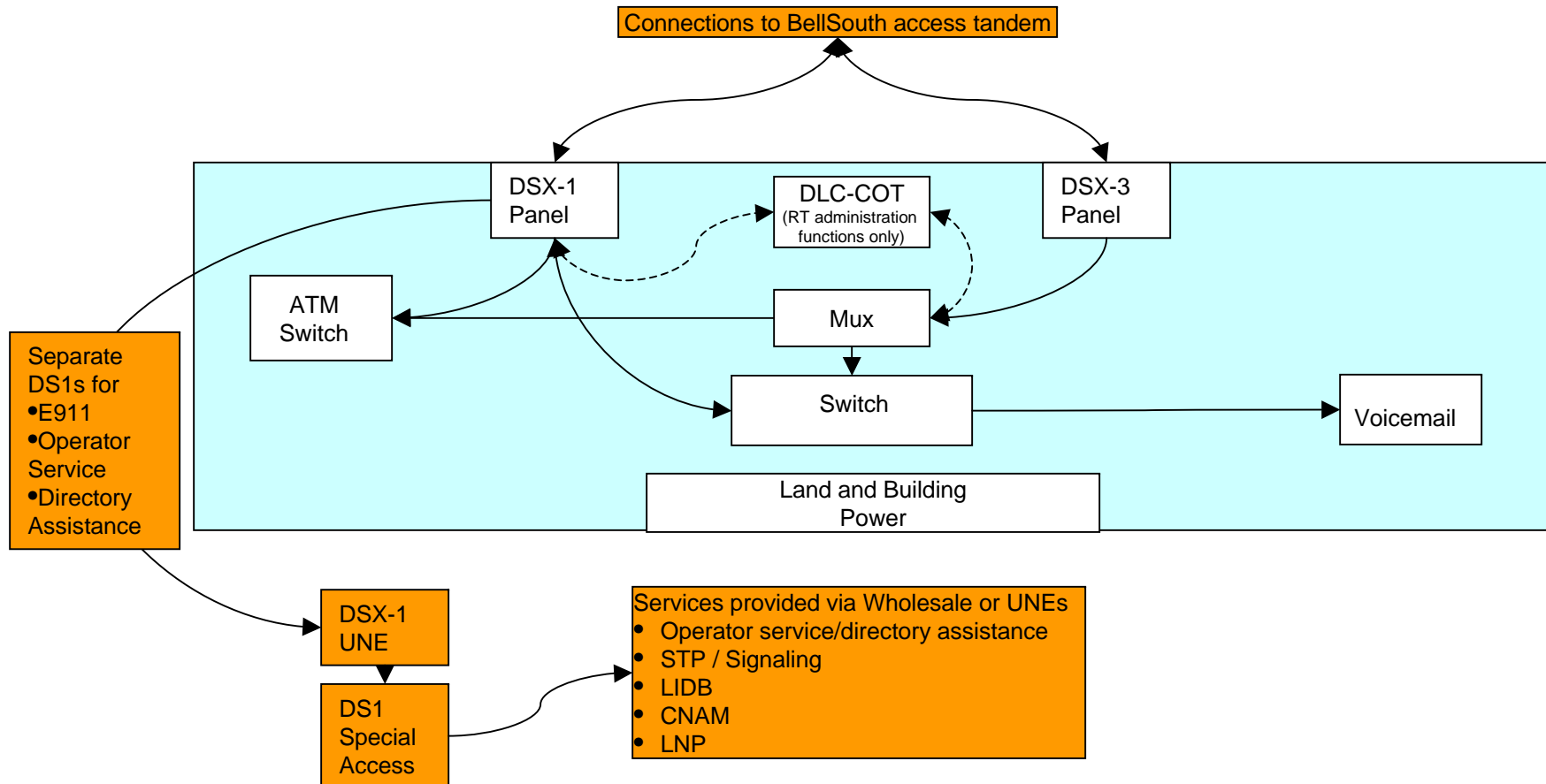

- Dark shading indicates BST provided (or wholesale purchase): White indicates CLEC provided, Light shading is CLEC space.