

TABLE OF CONTENTS

1. INTRODUCTION2

2. UNBUNDLED LOOPS, INTEGRATED DIGITAL LOOP CARRIERS, NETWORK INTERFACE DEVICES, UNBUNDLED LOOP CONCENTRATION (ULC) SYSTEM, SUB-LOOPS.....2

3. LOCAL SWITCHING21

4. COMBINATIONS (SWITCHED)27

5. OPERATOR SYSTEMS29

6. COMMON TRANSPORT32

7. DEDICATED TRANSPORT.....35

8. COMBINATIONS (NON-SWITCHED).....38

9. SIGNALING LINK TRANSPORT40

10. SIGNALING TRANSFER POINTS (STPS)42

11. SERVICE CONTROL POINTS/DATABASES48

12. TANDEM SWITCHING.....53

13. DARK FIBER55

14. ADDITIONAL REQUIREMENTS56

SERVICE DESCRIPTION: UNBUNDLED NETWORK ELEMENTS

1.0 Introduction

This Attachment sets forth the descriptions and requirements for unbundled network elements that BellSouth agrees to offer pursuant to the Generally Available Terms and Conditions.

2.0 Unbundled Loops, Integrated Digital Loop Carriers, Network Interfaces Device, Unbundled Loop Concentration (ULC) System, Sub loops

All of the terms and conditions set forth in this Section pertain to the provision of unbundled loops.

2.1 Unbundled Loops

2.1.1 All terms and conditions set forth in this Section pertain to the provision of unbundled loops.

2.1.1.1 The local loop Network Element ("Loop") is defined as a transmission facility between a distribution frame (or its equivalent) in BellSouth's central office and the loop demarcation point at an end-user customer premises, including inside wire owned by BellSouth. The local loop Network Element includes all features, functions, and capabilities of the transmission facilities, including dark fiber and attached electronics (except those used for the provision of advanced services, such as Digital Subscriber Line Access Multiplexers) and line conditioning.

2.1.1.2 The provisioning of a Loop to the CLEC's collocation space will require cross-office cabling and cross-connections within the central office to connect the Loop to a local switch or to other transmission equipment. These cross-connects are separate components, that are not considered a part of the Loop, and thus, have a separate charge.

2.1.1.3 To the extent available within BellSouth's network at a particular location, BellSouth will offer Loops capable of supporting telecommunications services. If a requested loop type is not available, and cannot be made available through BellSouth's Unbundled Loop Modification process, then the CLEC can use the Special Construction process to request that BellSouth place facilities in order respond to the request for Special Construction. The Loop intervals shall not apply to such a request.

2.1.1.4 Where facilities are available, BellSouth will install Loops in compliance with BellSouth's Products and Services Interval Guide available at the website at <http://www.interconnection.bellsouth.com>. For orders of 14 or more Loops, the installation and any applicable Order Coordination as

described below will be handled on a project basis, and the intervals will be set by the BellSouth project manager for that order. When Loops require a Service Inquiry (SI) prior to issuing the Order to determine if facilities are available, the interval for the SI process is separate from the installation interval.

- 2.1.1.5 If the CLEC cancels an order for Network Elements and other services, any costs incurred by BellSouth in conjunction with the provisioning of that order will be recovered in accordance with FCC No. 1 Tariff, Section 5. If the CLEC modifies an order after being sent a Firm Order Confirmation (FOC) from BellSouth, any costs incurred by BellSouth to accommodate the modification will be paid by the CLEC.
- 2.1.1.6 The Loop shall be provided to the CLEC in accordance with BellSouth's TR73600 Unbundled Local Loop Technical Specification and applicable industry standard technical references.
- 2.1.1.7 The CLEC may utilize the unbundled Loops to provide any telecommunications service it wishes, so long as such services are consistent with industry standards and BellSouth's TR73600.
- 2.1.1.8 BellSouth will only provision, maintain and repair the Loops to the standards that are consistent with the type of Loop ordered. In those cases where the CLEC has requested that BellSouth modify a Loop so that it no longer meets the technical parameters of the original Loop type (e.g., voice grade, ISDN, ADSL, etc.) the resulting Loop will be maintained as an unbundled copper Loop (UCL), and the CLEC shall pay the recurring and non-recurring charges for a UCL. For non-service specific loops (e.g. UCL, Loops modified by the CLEC using the Unbundled Loop Modification (ULM) process), BellSouth will only support that the Loop has copper continuity and balanced tip-and-ring.
- 2.1.1.9 The CLEC will be responsible for testing and isolating troubles on the Loops. Once the CLEC has isolated a trouble to the BellSouth provided Loop, and had issued a trouble report to BellSouth on the Loop, BellSouth will take the actions necessary to repair the Loop if a trouble actually exists. BellSouth will repair these Loops in the same time frames that BellSouth repairs similarly situated Loops to its end users.
- 2.2.2 Order Coordination and Order Coordination-Time Specific
 - 2.2.2.1 "Order Coordination" (OC) allows BellSouth and the CLEC to coordinate the installation of the SL2 Loops, Unbundled Digital Loops (UDL) and other Loops where OC may be purchased as an option, to the CLEC's facilities to limit end user service outage. OC is available when the Loop is provisioned over an existing circuit that is currently providing service to the end user. OC for physical conversions will be scheduled at

BellSouth's discretion during normal working hours on the committed due date. OC shall be provided in accordance with the chart set forth below.

2.2.2.2 "Order Coordination – Time Specific" (OC-TS) allows the CLEC to order a specific time for OC to take place. BellSouth will make every effort to accommodate the CLEC's specific conversion time request. However, BellSouth reserves the right to negotiate with the CLEC a conversion time based on load and appointment control when necessary. This OC-TS is a chargeable option for all Loops except Unbundled Copper Loops (UCL) and Universal Digital Channel (UDC), and is billed in addition to the OC charge. The CLEC may specify a time between 9:00 a.m. and 4:00 p.m. (location time) Monday through Friday (excluding holidays). If the CLEC specifies a time outside this window, or selects a time or quantity of Loops that requires BellSouth technicians to work outside normal work hours, overtime charges will apply in addition to the OC and OC-TS charges. Overtime charges will be applied based on the amount of overtime worked and in accordance with the rates established in the E Access Tariff, Section E13.2, for each state. The OC-TS charges for an order due on the same day at the same location will be applied on a per Local Service Request (LSR) basis.

	Order Coordination (OC)	Order Coordination – Time Specific (OC-TS)	Test Points	DLR	Charge for Dispatch and Testing if No Trouble Found
SL-1	Chargeable Option	Chargeable Option	Not available	Chargeable Option – ordered as Engineering Information Document	Charged for Dispatch inside and outside Central Office
UCL-ND	Chargeable Option	Not Available	Not Available	Chargeable Option – ordered as Engineering Information Document	Charged for Dispatch inside and outside Central Office
SL-2	Included	Chargeable Option	Included	Included	Charged for Dispatch outside Central Office
Unbundled Digital Loop	Included	Chargeable Option (except on Universal Digital Channel)	Included (where appropriate)	Included	Charged for Dispatch outside Central Office

	Order Coordination (OC)	Order Coordination – Time Specific (OC-TS)	Test Points	DLR	Charge for Dispatch and Testing if No Trouble Found
Unbundled Copper Loop	Chargeable in accordance with Section 2	Not available	Included	Included	Charged for Dispatch outside Central Office
For UVL-SL1 and UCLs, the CLEC must order and will be billed for both OC and OC-TS if requesting OC-TS.					

2.2.2.3 **Cancellation Charges.** If the CLEC cancels an order for network elements or other services, any costs incurred by BellSouth in conjunction with the provisioning of that order will be recovered in accordance with FCC No. 1 Tariff, Section 5.

2.2.2.4 **Expedite Charges.** For expedited requests by the CLEC, expedited charges will apply for intervals less than the standard interval as outlined in the BellSouth Product and Services Interval Guide. The charges as outlined in BellSouth’s FCC No. 1 Tariff, Section 5, will apply.

2.2.2.5 If the CLEC modifies an order (Order Modification Charge (OMC)) after being sent a Firm Order Confirmation (FOC) from BellSouth, any costs incurred by BellSouth to accommodate the modification will be paid by the CLEC in accordance with FCC No. 1 Tariff, Section 5.

2.3 Unbundled Voice Loops (UVLs)

2.3.1 BellSouth shall make available the following UVLs:

2.3.1.1 2-wire Analog Voice Grade Loop – SL1

2.3.1.2 2-wire Analog Voice Grade Loop – SL2

2.3.1.3 4-wire Analog Voice Grade Loop

2.3.2 Unbundled Voice Loops (UVL) may be provisioned using any type of facility that will support voice grade services. This may include loaded copper, non-loaded copper, digital loop carrier systems, fiber or a combination of any of these facilities. BellSouth, in the normal course of maintaining, repairing, and configuring its network, may also change the facilities that are used to provide any given voice grade circuit. This change may occur at any time. In these situations, BellSouth will only ensure that the newly provided facility will support voice grade services. BellSouth will not guarantee that the CLEC will be able to continue to

provide any advanced services over the new facility. BellSouth will offer UVL in two different service levels - Service Level One (SL1) and Service Level Two (SL2).

2.3.3 Unbundled Voice Loop - SL1 (UVL-SL1) loops are 2-wire loop start circuits, will be non-designed, and will not have remote access test points. OC will be offered as a chargeable option on SL1 loops when reuse of existing facilities has been requested by the CLEC. The CLEC may also order OC-TS when a specified conversion time is requested. OC-TS is a chargeable option for any coordinated order and is billed in addition to the OC charge. An Engineering Information (EI) document can be ordered as chargeable option. The EI document provides loop make up information which is similar to the information normally provided in a Design Layout Record. Upon issuance of a non-coordinated order in the service order system, SL1 loops will be activated on the due date in the same manner and time frames that BellSouth normally activates POTS-type loops for its customers.

2.3.4 Unbundled Voice Loop – SL2 (UVL-SL2) loops may be 2-wire or 4-wire circuits, shall have remote access test points, and will be designed with a design layout record provided to the CLEC. SL2 circuits can be provisioned with loop start, ground start or reverse battery signaling. OC is provided as a standard feature on SL2 loops. The OC feature will allow the CLEC to coordinate the installation of the loop with the disconnect of an existing customer's service and/or number portability service. In these cases, BellSouth will perform the order conversion with standard order coordination at its discretion during normal work hours.

2.4 Unbundled Digital Loops

2.4.1 BellSouth will also offer Unbundled Digital Loops (UDL). UDLs are service specific, will be designed, will be provisioned with test points (where appropriate), and will come standard with OC and a Design Layout Record (DLR). The various UDLs are intended to support a specific digital transmission scheme or service.

2.4.2 BellSouth shall make available the following UDLs:

2.4.2.1 2-wire Unbundled ISDN Digital Loop

2.4.2.2 2-wire Universal Digital Channel (IDSL Compatible)

2.4.2.3 2-wire Unbundled ADSL Compatible Loop

2.4.2.4 2-wire Unbundled HDSL Compatible Loop

2.4.2.5 4-wire Unbundled HDSL Compatible Loop

2.4.2.6 4-wire Unbundled DS1 Digital Loop

2.4.2.7 4-wire Unbundled Digital Loop/DS0 - 56 kbps, 64 kbps

2.4.2.8 DS3 Loop

2.4.2.9 STS-1 Loop

2.4.2.10 OC3 Loop

2.4.2.11 OC12 Loop

2.4.2.12 OC48 Loop

2.4.3 2-Wire Unbundled ISDN-Compatible Loop. This loop will be provisioned according to industry standards for 2-Wire Basic Rate ISDN services and will come standard with a test point, Order Coordination, and a DLR. The CLEC will be responsible for providing BellSouth with a Service Profile Identifier (SPID) associated with a particular ISDN-capable loop and end user. With the SPID, BellSouth will be able to adequately test the circuit and ensure that it properly supports ISDN service.

2.4.3.1 2 Wire Universal Digital Channel (UDC)/IDSL compatible loop. Due to technical limitations associated with certain Digital Loop Carrier (DLC) systems, some ISDN-compatible loops that are provisioned using DLC systems may not support IDSL (Integrated Digital Subscriber Line) service. BellSouth will not reconfigure its ISDN-capable loop to support IDSL service.

2.4.3.2 The IDSL-compatible loop (also known as Universal Digital Channel (UDC)) is intended to be compatible with IDSL service and has the same physical characteristics and transmission specifications as BellSouth's ISDN-capable loop. These specifications are listed in BellSouth's TR73600.

2.4.3.3 The IDSL-compatible loop may be provisioned on copper or through a Digital Loop Carrier (DLC) system. When IDSL-capable Loops are provisioned using a DLC system, the Loops will be provisioned on time slots that are compatible with data-only services such as IDSL.

2.4.4 2 or 4 Wire Unbundled HDSL-Compatible Loop. This is a designed loop that is provisioned according to Carrier Serving Area (CSA) criteria and may be up to 12,000 feet long and may have up to 2,500 feet of bridged tap (inclusive of loop length). It may be a 2-wire or 4-wire circuit and will come standard with a test point, Order Coordination, and a DLR.

2.4.5 2 Wire Unbundled ADSL-Compatible Loop. This is a designed loop that is provisioned according to Revised Resistance Design (RRD) criteria and

may be up to 18kft long and may have up to 6kft of bridged tap (inclusive of loop length). This 2-wire circuit comes standard with a test point, Order Coordination, and a DLR

2.4.6 4 Wire Unbundled DS1 Digital Loop. This is a designed 4-wire loop that is provisioned according to industry standards for DS1 or Primary Rate ISDN services and will come standard with a test point, Order Coordination, and a DLR.

2.4.7 4 Wire Unbundled Digital Loop/DS0. These are designed 4-wire loops that may be configured as 64kbps, 56kbps, 19kbps, and other sub-rate speeds associated with digital data services and will come standard with a test point, Order Coordination, and a DLR.

2.4.8 High Capacity Loops BellSouth also offers high capacity loops including DS3, STS-1, OC3, OC12 and OC48. These are designed loops that are provisioned according to industry standards and come standard with test point, Order Coordination and a DLR.

2.5 Unbundled Copper Loops (UCL)

2.6 BellSouth shall make available Unbundled Copper Loops (UCLs). The UCL is a copper twisted pair Loop that is unencumbered by any intervening equipment (e.g., filters, load coils, range extenders, digital loop carrier, or repeaters) and is not intended to support any particular telecommunications service. The UCL will be offered in two types – Short and Long.

2.6.1 BellSouth will make available the following UCL-Ds:

2.6.1.1 2-Wire UCL-D/short

2.6.1.2 2-Wire UCL-D/long

2.6.1.3 4-Wire UCL-D/short

2.6.1.4 4-Wire UCL-D/long

2.6.2 Unbundled Copper Loop – Designed (UCL-D)

2.6.2.1 The UCL-D will be provisioned as a dry copper twisted pair loop that is unencumbered by any intervening equipment (e.g., filters, load coils, range extenders, digital loop carrier, or repeaters). The UCL-D will be offered in two versions - Short and Long. A short UCL (18,000 feet or less) is provisioned according to Resistance Design parameters, may

have up to 6,000 feet of bridged tap and will have up to 1300 ohms of resistance.

2.6.2.2 The long UCL-D (beyond 18,000 feet) is provisioned as a dry copper twisted pair longer than 18,000 feet and may have up to 12,000 feet of bridged tap and up to 2800 ohms of resistance.

2.6.2.3 The UCL-D is a designed circuit, is provisioned with a test point and comes standard with a DLR. OC is required on UCLs where a reuse of existing facilities has been requested by the CLEC.

2.6.3 Unbundled Copper Loop – Non-Designed (UCL-ND)

2.6.3.1 The UCL-ND will be provisioned as a dedicated 2-wire metallic transmission facility from BellSouth's Main Distribution Frame to a customer's premises (including the NID). The UCL-ND will be a "dry copper" facility in that it will not have any intervening equipment such as load coils, repeaters, or digital access main lines ("DAMLs"), and may have up to 6,000 feet of bridged tap between the end user's premises and the serving wire center. The UCL-ND typically will be 1300 Ohms resistance and in most cases will not exceed 18,000 feet in length, although the UCL-ND will not have a specific length limitation. For loops less than 18,000 feet and with less than 1300 Ohms resistance, the loop will provide a voice grade transmission channel suitable for loop start signaling and the transport of analog voice grade signals. The UCL-ND will not be designed and will not be provisioned with either a design layout record or a test point.

2.6.3.2 The UCL-ND facilities may be mechanically assigned using BellSouth's assignment systems. Therefore, the Loop Make Up process is not required to order and provision the UCL-ND. However, the CLEC can request Loop Make Up for which additional charges would apply.

2.6.3.3 At an additional charge, BellSouth also will make available Loop Testing so that the CLEC may request further testing on the UCL-ND

2.6.3.4 UCL-ND loops are not intended to support any particular service and may be utilized by the CLEC to provide a wide-range of telecommunications services so long as those services do not adversely affect BST's network. The UCL-ND will include a Network Interface Device (NID) at the customer's location for the purpose of connecting the loop to the customer's inside wire.

2.6.3.5 Order Coordination (OC) will be provided as a chargeable option and may be utilized when the UCL-ND provisioning is associated with the reuse of

BST facilities. Order Coordination -Time Specific (OC-TS) does not apply to this product.

- 2.6.3.6 The CLEC may use BST's Unbundled Loop Modification (ULM) offering to remove bridge tap and/or load coils from any loop within the BST network. Therefore, some loops that would not qualify as UCL-ND could be transformed into loops that do qualify, using the ULM process.

2.7 Loop Testing/Trouble Reporting

- 2.7.1 The CLEC will be responsible for testing and isolating troubles on the loops. Once the CLEC has isolated a trouble to the BellSouth provided loop, the CLEC will issue a trouble to BellSouth on the loop. BellSouth will take the actions necessary to repair the loop if a trouble actually exists. BellSouth will repair these loops in the same time frames that BellSouth repairs similarly situated loops to its customers.
- 2.7.2 If the CLEC reports a trouble on a non-designed loop (e.g., UVL-SL1, UCL-ND, etc.) and no trouble actually exists, BellSouth will charge the CLEC for any dispatching and testing (both inside and outside the CO) required by BellSouth in order to confirm the loop's working status.
- 2.7.3 The CLEC must test and isolate trouble to the BellSouth portion of a designed unbundled loop (e.g., UVL-SL2, UCL-D, etc.) before reporting repair to the UNE Center. At the time of the trouble report, the CLEC will be required to provide the results of the CLEC test which indicate a problem on the BellSouth provided loop. If the CLEC reports a trouble on a designed loop and no trouble actually exists, BellSouth will charge the CLEC for any dispatching and testing, (outside the CO) required by BellSouth in order to confirm the loop's working status.
- 2.7.4 Services provided over unbundled loops by the CLEC will be consistent with industry standards and BellSouth's TR73600 for the loop type ordered. The CLEC may utilize the unbundled loops to provide any telecommunication service it wishes. However, BellSouth will only provision, maintain and repair the loops to the standards that are consistent with the type of loop ordered. For example, if the CLEC orders an ISDN-capable loop but wants to use the loop for a service other than ISDN, BellSouth will only support that the loop is capable of providing ISDN service. For non-service specific loops (e.g. UCL, loops modified by the CLEC using the Special Construction process), BellSouth will only support that the loop has copper continuity and balanced tip-and-ring.

2.8 Unbundled Loop Modifications (Line Conditioning)

- 2.8.1 BellSouth shall condition Loops, as requested by the CLEC, whether BellSouth offers advanced services to the End User on that Loop.
- 2.8.2 In some instances, the CLEC will require access to a copper twisted pair loop unfettered by any intervening equipment (e.g., filters, load coils, range extenders, etc.), so that the CLEC can use the loop for a variety of services by attaching appropriate terminal equipment at the ends. The CLEC will determine the type of service that will be provided over the loop. BellSouth's Unbundled Loop Modifications (ULM) process will be used to determine the costs and feasibility of conditioning the loops as requested. Rates for ULM are as set forth in Exhibit C of this Attachment 2.
- 2.8.3 Loop conditioning is defined as the removal from the Loop of any devices that may diminish the capability of the Loop to deliver high-speed switched wireline telecommunications capability, including xDSL service. Such devices include, but are not limited to, load coils, bridge taps, low pass filters, and range extenders.
- 2.8.4 In those cases where the CLEC has requested that BellSouth modify a loop so that it no longer meets the technical parameters of the original loop type (e.g., voice grade, ISDN, ADSL, etc.) the resulting modified loop will be ordered and maintained as a UCL.
- 2.8.5 The Unbundled Loop Modifications (ULM) offering provides the following elements: 1) removal of devices on 2-wire or 4-wire Loops equal to or less than 18,000 feet; 2) removal of devices on 2-wire or 4-wire Loops longer than 18,000 feet; and 3) removal of bridged-taps on loops of any length.
- 2.8.6 The CLEC shall request Loop make up information at rates contained in Attachment A prior to submitting a service inquiry and/or a LSR for the Loop type that the CLEC desires BellSouth to condition.
- 2.8.7 BellSouth shall recover the cost of line conditioning requested by the CLEC through the rates contained in Attachment A.
- 2.9 Loop Provisioning Involving Integrated Digital Loop Carriers**
- 2.9.1 Where the CLEC has requested an Unbundled Loop and BellSouth uses Integrated Digital Loop Carrier (IDLC) systems to provide the local service to the end user and BellSouth has a suitable alternate facility available, BellSouth will make such alternative facilities available to the CLEC. If a suitable alternative facility is not available, then to the extent it is technically feasible, BellSouth will make alternative arrangements available to the CLEC (e.g. hairpinning).
- 2.9.2 BellSouth will select one of the following arrangements:

1. Roll the circuit(s) from the IDLC to any spare copper that exists to the customer premises.
2. Roll the circuit(s) from the IDLC to an existing DLC that is not integrated.
3. If capacity exists, provide "side-door" porting through the switch.
4. If capacity exists, provide "DACS-door" porting (if the IDLC routes through a DACS prior to integration into the switch).

2.9.3 Arrangements 3 and 4 above require the use of a designed circuit. Therefore, non-designed loops such as the SL1 voice grade and UCL-ND may not be ordered in these cases.

2.9.4 If no alternate facility is available, BellSouth will utilize its Special Construction (SC) process to determine the additional costs required to provision the loop facilities. The CLEC will then have the option of paying the one-time SC rates to place the loop.

2.10 Network Interface Device (NID)

2.10.1 Definition

2.10.1.1 The NID is defined as any means of interconnection of end-user customer premises wiring to BellSouth's distribution plant, such as a cross-connect device used for that purpose. The NID is a single-line termination device or that portion of a multiple-line termination device required to terminate a single line or circuit at the premises. The NID features two independent chambers or divisions that separate the service provider's network from the end user's customer-premises wiring. Each chamber or division contains the appropriate connection points or posts to which the service provider and the end user each make their connections. The NID provides a protective ground connection and is capable of terminating cables such as twisted pair cable.

2.10.1.2 BellSouth shall permit the CLEC to connect the CLEC's loop facilities the end-user's customer-premises wiring through the BellSouth NID or at any other technically feasible point.

2.10.2 Access to NID

2.10.2.1 The CLEC may access the end user's customer-premises wiring by any of the following means:

2.10.2.1.1 1) BellSouth shall allow the CLEC to connect its loops directly to BellSouth's multi-line residential NID enclosures that have additional space and are not used by BellSouth or any other telecommunications carriers to provide service to the premises. The CLEC shall not disturb

the existing form of electrical protection and shall maintain the physical integrity of the NID;

- 2.10.2.1.2 2) Where an adequate length of the end user's customer premises wiring is present and environmental conditions permit, either Party may remove the customer premises wiring from the other Party's NID and connect such wiring to that Party's own NID;
- 2.10.2.1.3 3) Enter the subscriber access chamber or dual chamber NID enclosures for the purpose of extending a connect divisioned or spliced jumper wire from the customer premises wiring through a suitable "punch-out" hole of such NID enclosures; or
- 2.10.2.1.4 4) Request BellSouth to make other rearrangements to the end user customer premises wiring terminations or terminal enclosure on a time and materials cost basis.
- 2.10.2.2 In no case shall either Party remove or disconnect the other Party's loop facilities from either Party's NIDs, enclosures, or protectors unless the applicable Commission has expressly permitted the same and the disconnecting Party provides prior notice to the other Party. In such cases, it shall be the responsibility of the Party disconnecting loop facilities to leave undisturbed the existing form of electrical protection and to maintain the physical integrity of the NID. It will be the CLEC's responsibility to ensure there is no safety hazard and will hold BellSouth harmless for any liability associated with the removal of the BellSouth loop from the BellSouth NID. Furthermore, it shall be the responsibility of the disconnecting Party, once the other Party's loop has been disconnected from the NID, to reconnect the disconnected loop to a nationally recognized testing laboratory listed station protector, which has been grounded as per Article 800 of the National Electrical Code. If no spare station protector exists in the NID, the disconnected loop must be appropriately cleared, capped and stored.
- 2.10.2.3 In no case shall either Party remove or disconnect ground wires from BellSouth's NIDs, enclosures, or protectors.
- 2.10.2.4 In no case shall either Party remove or disconnect NID modules, protectors, or terminals from BellSouth's NID enclosures.
- 2.10.3 Technical Requirements
- 2.10.3.1 The NID shall provide an accessible point of interconnection and shall maintain a connection to ground.

2.10.3.2 If an existing NID is accessed, it shall be capable of transferring electrical analog or digital signals between the end user's customer premises and the Distribution Media and/or cross connect to the CLEC's NID.

2.10.3.3 Existing BellSouth NIDs will be provided in "as is" condition. The CLEC may request BellSouth do additional work to the NID on a time and material basis. When the CLEC deploys its own local loops with respect to multiple-line termination devices, the CLEC shall specify the quantity of NIDs connections that it requires within such device.

2.11 Sub-loop Elements

2.11.1 Where facilities permit, BellSouth shall offer access to its Unbundled Sub Loop (USL) and Unbundled Sub-loop Concentration (USLC) System.

2.11.2 Unbundled Sub-Loop Distribution

2.11.2.1 The unbundled sub-loop distribution facility is dedicated transmission facility that BellSouth provides from an end user's point of demarcation to a BellSouth cross-connect device. The BellSouth cross-connect device may be located within a remote terminal (RT) or a stand-alone cross-box in the field or in the equipment room of a building. The unbundled sub-loop distribution media is a copper twisted pair that can be provisioned as a 2 Wire or 4 Wire facility. BellSouth will make the following available sub-loop distribution offerings where facilities permit:

Unbundled Sub-Loop Distribution – Voice Grade

Unbundled Copper Sub-Loop

Unbundled Sub-Loop Distribution – Intrabuilding Network Cable (aka riser cable)

2.11.2.2 Unbundled Sub-Loop Distribution – Voice Grade (USLD-VG) is a sub-loop facility from the cross-box in the field up to and including the point of demarcation, at the end user's premises and may have load coils. USLD-VG facilities were originally built as part of the entire voice grade loop from the BellSouth central office to the customer network interface. Therefore, the USLD-VG may have load coils, which are necessary for transmission of voice grade services.

2.11.2.3 Unbundled Copper Sub-Loop (UCSL) is a non-loaded copper facility of any length provided from the cross-box in the field up to and including the end-user's point of demarcation. If available, this facility will not have any intervening equipment such as load coils between the end-user and the cross-box.

2.11.2.4 If the CLEC requests a UCSL and it is not available, the CLEC may request the Sub-Loop facility be modified pursuant to the ULM process

request to remove load coils and/or bridged taps. If load coils and/or bridged taps are removed, the facility will be classified as a UCSL.

- 2.11.2.5 Unbundled Sub-Loop Distribution – Intrabuilding Network Cable** (USLD-INC) is the distribution facility inside a building or between buildings on the same continuous property and is not separated by a public street or road. USLD-INC includes the facility from the cross-connect device in the building equipment room up to and including the point of demarcation, at the end user's premises. BellSouth will install a cross connect panel in the building equipment room for the purpose of accessing USLD-INC pairs. The cross-connect panel will function as a single point of interconnection (SPOI) for USLD-INC and will be accessible by multiple carriers as space permits. BellSouth will place cross-connect blocks in 25-pair increments for the CLEC's use on this cross-connect panel. The CLEC will be responsible for connecting its facilities to the 25-pair cross-connect block(s).
- 2.11.2.6 Unbundled Sub-Loop distribution facilities shall support functions associated with provisioning, maintenance and testing of the Unbundled Sub-Loop. For access to Voice Grade USL-D and UCSL, the CLEC shall deliver a cable to the BellSouth cross-box pursuant to the terms and conditions for physical collocation for remote sites set forth in this Agreement. This cable would be connected by a BellSouth technician within the BellSouth cross-box during the set-up process. The CLEC's cable pairs can then be connected to BellSouth's USL within the BellSouth cross-box by the BellSouth technician.
- 2.11.2.7 Through the Service Inquiry (SI) process, BellSouth will determine whether access to Unbundled Sub-Loops at the location requested by the CLEC is technically feasible and whether sufficient capacity exists in the cross-box. If existing capacity is sufficient to meet the CLEC's request, then BellSouth will perform the set-up as described in the section that follows. If any work must be done to modify existing BellSouth facilities or add new facilities (other than adding the cross-connect panel in a building equipment room as noted in the section that follows) to accommodate the CLEC's request for Unbundled Sub-Loops, the CLEC may request BellSouth's Special Construction (SC) process to determine additional costs required to provision the Unbundled Sub-Loops. The CLEC will have the option to proceed under the SC process to modify the BellSouth facilities.
- 2.11.2.8 Set-up must be completed before the CLEC can order sub-loop pairs. For the site set-up in a BellSouth cross-connect box in the field, BellSouth will perform the necessary work to splice the CLEC's cable into the cross-connect box. For the site set-up inside a building equipment room, BellSouth will perform the necessary work to install the cross-connect

panel and the connecting block(s) that will be used to provide access to the requested USLs.

2.11.2.9 Once the set-up is complete, the CLEC will request sub-loop pairs through submission of a Local Service Request (LSR) form to the Local Carrier Service Center (LCSC). Order Coordination is required with USL pair provisioning when the CLEC requests reuse of an existing facility and is in addition to the USL pair rate. For expedite requests by the CLEC for sub-loop pairs, expedite charges will apply for intervals less than 5 days.

2.11.2.10 Unbundled Sub-Loops will be provided in accordance with technical reference TR73600.

2.11.3 Unbundled Network Terminating Wire (UNTW)

2.11.3.1 Service Description

2.11.3.1.1 Unbundled Network Terminating Wire (UNTW) is unshielded twisted copper wiring that is used to extend circuits from an intra-building network cable terminal or from a building entrance terminal to an individual customer's point of demarcation. It is the final portion of the Loop, which, in multi-subscriber configurations, represents the point at which, the network branches out to serve individual subscribers.

2.11.3.2 Basic Service Features

2.11.3.2.1 This element will be provided in Multi-Dwelling Units (MDUs) and/or Multi-Tenants Units (MTUs) where BellSouth owns wiring all the way to the end-users premises. BellSouth will not provide this element in those locations where the property owner provides its own wiring to the end-user's premises, where a third party owns the wiring to the end-user's premises or where the property owner will not allow BellSouth to place its facilities to the end user.

2.11.3.3 Requirements

2.11.3.3.1 On a multi-unit premises, upon request of the other Party ("Requesting Party"), the Party owning the network terminating wire will provide access to UNTW pairs on an Access Terminal that is suitable for use by multiple carriers at each Garden Terminal or Wiring Closet.

2.11.3.4 The Provisioning Party shall not be required to install new or additional NTW beyond existing NTW to provision the services of the Requesting Party.

2.11.3.5 Upon receipt of the UNTW Service Inquiry (SI) requesting access to the Provisioning Party's UNTW pairs at a multi-unit premises, representatives

of both Parties will participate in a meeting at the site of the requested access. The purpose of the site visit will include discussion of the procedures for installation and location of the Access Terminals. By request of the Requesting Party, an Access Terminal will be installed either adjacent to each Provisioning Party's Garden Terminal or inside each Wiring Closet. Requesting Party will deliver and connect its central office facilities to the UNTW pairs within the Access Terminal. Requesting Party may access any available pair on an Access Terminal. A pair is available when a pair is not being utilized to provide service or where the end user has requested a change in its local service provider to the Requesting Party. Prior to connecting Requesting Party's service on a pair previously used by Provisioning Party, Requesting Party is responsible for ensuring the end-user is no longer using Provisioning Party's service or another CLEC's service before accessing UNTW pairs.

- 2.11.3.6 Access Terminal installation intervals will be established on an individual case basis.
- 2.11.3.7 Requesting Party is responsible for obtaining the property owner's permission for Provisioning Party to install an Access Terminal(s) on behalf of the Requesting Party. The submission of the SI by the Requesting Party will serve as certification by the Requesting Party that such permission has been obtained. If the property owner objects to Access Terminal installations that are in progress or subsequent to completion and demands removal of Access Terminals, Requesting Party will be responsible for costs associated with removing Access Terminals and restoring property to its original state prior to Access Terminals being installed.
- 2.11.3.8 The Requesting Party shall indemnify and hold harmless the Provisioning Party against any claims of any kind that may arise out of the Requesting Party's future to obtain the property owner's permission. Requesting Party will be billed for non-recurring and recurring charges for accessing UNTW pairs at the time the Requesting Party activates the pair(s). The Requesting Party will notify the Provisioning Party each time it activates UNTW pairs using the LSR form.
- 2.11.3.9 Requesting Party will isolate and report troubles in the manner specified by the Provisioning Party. Requesting Party must tag the UNTW pair that requires repair. If Provisioning Party dispatches a technician on a reported trouble call and no UNTW trouble is found, Provisioning Party will charge Requesting Party for time spent on the dispatch and testing the UNTW pair(s).
- 2.11.3.10 If Requesting Party initiates the Access Terminal installation and the Requesting Party has not activated at least one pair on the Access Terminal installed pursuant to Requesting Party's request for an Access

Terminal within 6 months of installation of the Access Terminal, Provisioning Party will bill Requesting Party a non-recurring charge equal to the actual cost of provisioning the Access Terminal.

- 2.11.3.11 If Provisioning Party determines that Requesting Party is using the UNTW pairs without reporting the activation of the pairs, the following charges shall apply:
- 2.11.3.12 If Requesting Party issued a LSR to disconnect an end-user from Provisioning Party in order to use a UNTW pair, Requesting Party will be billed for the use of the pair back to the disconnect order date.
- 2.11.3.13 If Requesting Party activated a UNTW pair on which Provisioning Party was not previously providing service, Requesting Party will be billed for the use of that pair back to the date the end-user began receiving service using that pair. Upon request, Requesting Party will provide copies of its billing record to substantiate such date. If Requesting Party fails to provide such records, then Provisioning Party will bill the Requesting Party back to the date of the Access Terminal installation.

2.11.4 Unbundled Sub-Loop Feeder

2.11.4.1 Definition

2.11.4.1.1 Unbundled Sub-Loop Feeder (USLF) provides connectivity between BellSouth's central office and cross-box (or other access point) that serves an end user location.

2.11.4.2 USLF utilized for voice traffic can be configured as 2-wire voice (USLF-2W/V) or 4-wire voice (USLF-4W/V).

2.11.4.3 USLF utilized for digital traffic can be configured as 2-wire ISDN (USLF-2W/I); 2-wire Copper (USLF-2W/C); 4-wire Copper (USLF-4W/C); 4-wire DS0 level loop (USLF-4W/D0); or 4-wire DS1 and ISDN (USLF-4W/DI).

2.11.4.4 USLF will provide access to both the equipment and the features in the BellSouth central office and BellSouth cross box necessary to provide a 2W or 4W communications pathway from the BellSouth central office to the BellSouth cross-box. This element will allow for the connection of the CLEC's loop distribution elements onto BellSouth's feeder system.

2.11.5 Requirements

2.11.5.1 The CLEC will extend a compatible cable to BellSouth's cross-box. BellSouth will connect the cable to a panel inside the BellSouth cross-box to the requested level of feeder element. In those cases when there is no room in the BellSouth cross-box to accommodate the additional cross-

connect panels mentioned above, BellSouth will utilize its Special Construction process to determine the costs to provide the sub-loop feeder element to the CLEC. The CLEC will then have the option of paying the special construction charges or canceling the order.

2.11.5.2 USLF will be a designed circuit and BellSouth will provide a Design Layout Record (DLR) for this element.

2.11.5.3 BellSouth will provide USLF elements in accordance with applicable industry standards for these types of facilities. Where industry standards do not exist, BellSouth's TR73600 will be used to determine performance parameters.

2.11.6 Unbundled Loop Concentration (ULC)

2.11.6.1 BellSouth will provide to the CLEC Unbundled Loop Concentration (ULC). Loop concentration systems in the central office concentrate the signals transmitted over local loops onto a digital loop carrier system. The concentration device is placed inside a BellSouth central office. BellSouth will offer ULC with a TR008 interface or a TR303 interface.

2.11.6.2 ULC will be offered in two sizes. System A will allow up to 96 BellSouth loops to be concentrated onto multiple DS1s. The high-speed connection from the concentrator will be at the electrical DS1 level and will connect to the CLEC at the CLEC's collocation site. System B will allow up to 192 BellSouth loops to be concentrated onto multiple DS1s. System A may be upgraded to a System B. A minimum of two DS1s is required for each system (i.e., System A requires two DS1s and System B would require an additional two DS1s or four in total). All DS1 interfaces will terminate to the CLEC's collocation space. ULC service is offered with concentration (2 DS1s for 96 channels) or without concentration (4 DS1s for 96 channels) and with or without protection. A Loop Interface element will be required for each loop that is terminated onto the ULC system. Rates for ULC are as set forth in this Attachment.

2.11.7 Unbundled Sub-Loop Concentration (USLC)

2.11.7.1 Where facilities permit and where necessary to comply with an effective Commission order, BellSouth will provide the CLEC with the ability to concentrate its sub-loops onto multiple DS1s back to the BellSouth Central Office. The DS1s will then be terminated into the CLEC's collocation space. TR-008 and TR303 interface standards are available.

2.11.7.2 USLC, using the Lucent Series 5 equipment, will be offered in two different systems. System A will allow up to 96 of the CLEC's sub-loops to be concentrated onto multiple DS1s. System B will allow an additional 96 of the CLEC's sub-loops to be concentrated onto multiple DS1s. One

System A may be supplemented with one System B and they both must be physically located in a single Series 5 dual channel bank. A minimum of two DS1s is required for each system (i.e., System A requires two DS1s and System B would require an additional two DS1s or four in total). The DS1 level facility that connects the RT site with the serving wire center is known as a Feeder Interface. All DS1 Feeder Interfaces will terminate to the CLEC's collocation space within the SWC that serves the RT where the CLEC's sub-loops are connected. USLC service is offered with or without concentration and with or without a protection DS1.

- 2.11.7.3 In these scenarios the CLEC would be required to place a cross-box, remote terminal (RT), or other similar device and deliver a cable to the BellSouth RT. This cable would be connected, by a BellSouth technician, to a cross-connect panel within the BellSouth RT/cross-box and would allow the CLEC's sub-loops to then be placed on the ULSC and transported to their collocation space at a DS1 level.

2.11.8 Access to Loop Make-up

- 2.11.8.1 BellSouth provides electronic access to loop make-up information through the Local Exchange Navigation System (LENS) and the Telecommunications Access Gateway (TAG). TAG is a machine-to-machine interface that provides real-time interactive access to BellSouth's databases. LENS is a human-to-machine interface for use by those CLECs who choose not to use machine-to-machine interfaces. BellSouth also provides manual access to loop make-up information.

2.11.9 Access to the High Frequency Portion of the Loop

- 2.11.9.1 BellSouth provides CLECs access to the high frequency portion of the loop network element as an unbundled network element where BellSouth is providing, and continues to provide, analog circuit-switched voiceband services on the particular loop for which the CLEC seeks access. The high frequency portion of the loop is defined as the frequency range above the voiceband on a copper loop facility that is being used to carry analog circuit-switched voiceband transmissions. BellSouth may maintain control over the loop and splitter equipment and functions, and will provide CLECs with loop and splitter functionality that is compatible with any transmission technology that the CLEC seeks to deploy using the high frequency portion of the loop, as defined in 47 C.F.R. § 51.319(h), provided that such transmission technology is presumed to be deployable pursuant to 47 C.F.R. § 51.230. BellSouth also offers CLECs the option of purchasing, installing, and maintaining central office POTS splitters in its collocation arrangements. Any splitters installed by the CLECs in its collocation arrangements shall comply with ANSI T1.413, Annex E, or any future ANSI splitter standards. BellSouth shall also permit CLECs to install any splitters in that BellSouth deploys or permits to be deployed for

itself or any BellSouth Affiliate. BellSouth will also provide line sharing splitters at its remote sites to allow CLECs access to the high frequency spectrum of copper sub-loops terminated at that remote site, where the CLEC has a collocated DSLAM. BellSouth will condition loops to enable CLECs to access the high frequency portion of the loop spectrum in accordance with 47 C.F.R. § 51.319(a)(3) and § 51.319(h).

3.0 Switching

3.0.1 All of the terms and conditions set forth in this Section pertain to the provision of local and tandem switching.

3.1 Local Switching

3.1.1 BellSouth shall provide non-discriminatory access to local circuit switching capability, and local tandem switching capability, on an unbundled basis, except as set forth below in Section 3.1.4.1 to the CLEC for the provision of a telecommunications service. BellSouth shall provide non-discriminatory access to packet switching capability on an unbundled basis to the CLEC for the provision of a telecommunications service only in the limited circumstance described below in Section 3.2.6.

3.1.2 Except as otherwise provided herein, BellSouth shall not impose any restrictions on the CLEC regarding the use of Switching Capabilities purchased from BellSouth provided such use does not result in demonstrable harm to either the BellSouth network or personnel or the use of the BellSouth network by BellSouth or any other telecommunication carrier.

3.1.3 Local Circuit Switching Capability, including Tandem Switching Capability

3.1.3.1 Definition

3.1.4 Local Circuit Switching Capability is defined as: (A) line-side facilities, which include, but are not limited to, the connection between a loop termination at a main distribution frame and a switch line card; (B) trunk-side facilities, which include, but are not limited to, the connection between trunk termination at a trunk-side cross-connect panel and a switch trunk card; and (C) All features, functions, and capabilities of the switch, which include, but are not limited to: (1) the basic switching function of connecting lines to lines, line to trunks, trunks to lines, and trunks to trunks, as well as the same basic capabilities made available to BellSouth's customers, such as a telephone number, white page listings, and dial tone; and (2) all other features that the switch is capable of providing, including but not limited to customer calling, customer local area signaling service features, and Centrex, as well as any technically

feasible customized routing functions provided by the switch; (D) switching provided by remote switching modules.

- 3.1.4.1 Notwithstanding BellSouth's general duty to unbundle local circuit switching, BellSouth shall not be required to unbundle local circuit switching for the CLEC when the CLEC serves end-users with four (4) or more voice-grade (DS-0) equivalents or lines in locations served by BellSouth's local circuit switches, which are in the following MSAs: Atlanta, GA; Miami, FL; Orlando, FL; Ft. Lauderdale, FL; Charlotte-Gastonia-Rock Hill, NC; Greensboro-Winston Salem-High Point, NC; Nashville, TN; and New Orleans, LA, and BellSouth has provided non-discriminatory cost based access to the Enhanced Extended Link (EEL) throughout Density Zone 1 as determined by NECA Tariff No. 4 as in effect on January 1, 1999.
- 3.1.4.2 In the event that the CLEC orders local circuit switching for a single end user account name with four (4) or more two (2) wire voice-grade loops within a top 50 MSA, Density Zone 1, BellSouth's sole recourse shall be to charge the CLEC a market based-rate for use of the local circuit switching functionality for the affected facilities.
- 3.1.4.3 A port includes all features then capable or a number of then capable features specifically requested by the CLEC. Any features that are not currently then capable but are technically feasible through the switch can be requested through the BFR process.
- 3.1.4.4 BellSouth will provide to the CLEC customized routing of calls: (i) to a requested directory assistance services platform; (ii) to an operator services platform; (iii) for the CLEC's PIC'ed toll traffic in a two (2) PIC environment to an alternative OS/DA platform designated by the CLEC. The CLEC's customers may use the same dialing arrangements as BellSouth customers.
- 3.1.4.5 Remote Switching Module functionality is included in Switching Capability. The switching capabilities used will be based on the line side features they support.
- 3.1.4.6 Switching Capability will also be capable of routing local, intraLATA, interLATA, and calls to international customer's preferred carrier; call features (e.g. call forwarding) and Centrex capabilities.
- 3.1.4.7 Where required to do so in order to comply with an effective Commission order, BellSouth will provide to the CLEC purchasing local BellSouth switching and reselling BellSouth local exchange service under Section XIV of the SGAT, selective routing of calls to a requested directory assistance services platform or operator services platform. The CLEC's

customers may use the same dialing arrangements as BellSouth customers, but obtain the CLEC's branded service.

3.1.5 Technical Requirements

- 3.1.5.1 The requirements set forth in this Section apply to Local Switching, but not to the Data Switching function of Local Switching.
- 3.1.5.2 Local Switching shall be equal to or better than the requirements for Local Switching set forth in the applicable industry standard technical references.
- 3.1.5.3 When applicable, BellSouth shall route calls to the appropriate trunk or lines for call origination or termination.
- 3.1.5.4 Subject to this section, BellSouth shall route calls on a per line or per screening class basis to (1) BellSouth platforms providing Network Elements or additional requirements (2) Operator Services platforms, (3) Directory Assistance platforms, and (4) Repair Centers. Any other routing requests by the CLEC will be made pursuant to the Bona Fide Request Process as set forth in General Terms and Conditions.
- 3.1.5.5 BellSouth shall provide unbranded recorded announcements and call progress tones to alert callers of call progress and disposition.
- 3.1.5.6 BellSouth shall activate service for a CLEC's customer or network interconnection on any of the Local Switching interfaces. This includes provisioning changes to change a customer from BellSouth's services to the CLEC's services without loss of switch feature functionality as defined in this Agreement.
- 3.1.5.7 BellSouth shall perform routine testing (e.g., Mechanized Loop Tests (MLT) and test calls such as 105, 107 and 108 type calls) and fault isolation on a mutually agreed upon schedule.
- 3.1.5.8 BellSouth shall repair and restore any equipment or any other maintainable component that may adversely impact Local Switching.
- 3.1.5.9 BellSouth shall control congestion points such as those caused by radio station call-ins, and network routing abnormalities. All traffic shall be restricted in a non-discriminatory manner.
- 3.1.5.10 BellSouth shall perform manual call trace and permit customer originated call trace.
- 3.1.5.11 Special Services provided by BellSouth will include the following:
 - 3.1.5.11.1 Telephone Service Prioritization;

- 3.1.5.11.2 Related services for handicapped;
- 3.1.5.11.3 Soft dial tone where required by law; and
- 3.1.5.11.4 Any other service required by law.
- 3.1.5.12 BellSouth shall provide Switching Service Point (SSP) capabilities and signaling software to interconnect the signaling links destined to the Signaling Transfer Point Switch (STPS). These capabilities shall adhere to the technical specifications set forth in the applicable industry standard technical references.
- 3.1.5.13 BellSouth shall provide interfaces to adjuncts through Telcordia (formerly BellCore) standard interfaces. These adjuncts can include, but are not limited to, the Service Circuit Node and Automatic Call Distributors.
- 3.1.5.14 BellSouth shall provide performance data regarding a customer line, traffic characteristics or other measurable elements to the CLEC, upon a reasonable request from the CLEC. The CLEC will pay BellSouth for all costs incurred to provide such performance data through the Business Opportunity Request process.
- 3.1.5.15 BellSouth shall offer Local Switching that provides feature offerings at parity to those provided by BellSouth to itself or any other Party.
- 3.1.5.16 BellSouth shall offer to the CLEC all AIN triggers in connection with its SMS/SCE offering which are supported by BellSouth for offering AIN-based services
- 3.1.5.17 Where capacity exists, BellSouth shall assign each CLEC customer line the class of service designated by the CLEC (e.g., using line class codes or other switch specific provisioning methods), and shall route directory assistance calls from the CLEC's customers to the CLEC's directory assistance operators at the CLEC's option.
- 3.1.5.18 Where capacity exists, BellSouth shall assign each CLEC customer line the class of service designated by the CLEC (e.g., using line class codes or other switch specific provisioning methods) and shall route operator calls from the CLEC's customers to the CLEC's operators at the CLEC's option. For example, BellSouth may translate 0- and 0+ intraLATA traffic, and route the call through appropriate trunks to the CLEC Operator Services Position System (OSPS). Calls from Local Switching must pass the ANI-II digits unchanged.
- 3.1.5.19 Local Switching shall be offered in accordance with the technical specifications set forth in the applicable industry standard references.

- 3.1.6 Interface Requirements BellSouth shall provide the following interfaces to loops:
 - 3.1.6.1 Standard Tip/Ring interface including loopstart or groundstart, on-hook signaling (e.g., for calling number, calling name and message waiting lamp);
 - 3.1.6.2 Coin phone signaling;
 - 3.1.6.3 Basic Rate Interface ISDN adhering to appropriate Telcordia (formerly BellCore) Technical Requirements;
 - 3.1.6.4 Two-wire analog interface to PBX;
 - 3.1.6.5 Four-wire analog interface to PBX;
 - 3.1.6.6 Four-wire DS1 interface to PBX or customer provided equipment (e.g. computers and voice response systems);
 - 3.1.6.7 Primary Rate ISDN to PBX adhering to ANSI standards Q.931, Q.932 and appropriate Telcordia (formerly BellCore) Technical Requirements;
 - 3.1.6.8 Switched Fractional DS1 with capabilities to configure Nx64 channels (where N = 1 to 24); and
 - 3.1.6.9 Loops adhering to Telcordia (formerly BellCore) TR-NWT-08 and TR-NWT-303 specifications to interconnect Digital Loop Carriers.
- 3.1.7 BellSouth shall provide access to the following but not limited to:
 - 3.1.7.1 SS7 Signaling Network or Multi-Frequency trunking if requested by the CLEC;
 - 3.1.7.2 Interface to the CLEC operator services systems or Operator Services through appropriate trunk interconnections for the system; and
 - 3.1.7.3 Interface to the CLEC Directory Assistance Services through the CLEC's switched network or to Directory Assistance Services through the appropriate trunk interconnections for the system; and 950 access or other CLEC required access to interexchange carriers as requested through appropriate trunk interfaces.

3.2 Packet Switching Capability

3.2.1 Definition

Packet Switching Capability. The packet switching capability network element is defined as the basic packet switching function of routing or forwarding packets, frames, cells or other data units based on address or other routing information contained in the packets, frames, cells or other data units, and the functions that are performed by Digital Subscriber Line Access Multiplexers, including but not limited to:

- 3.2.2 The ability to terminate copper customer loops (which includes both a low band voice channel and a high-band data channel, or solely a data channel);
- 3.2.3 The ability to forward the voice channels, if present, to a circuit switch or multiple circuit switches;
- 3.2.4 The ability to extract data units from the data channels on the loops, and
- 3.2.5 The ability to combine data units from multiple loops onto one or more trunks connecting to a packet switch or packet switches.
- 3.2.6 BellSouth shall be required to provide non-discriminatory access to unbundled packet switching capability only where each of the following conditions are satisfied:
 - 3.2.6.1 BellSouth has deployed digital loop carrier systems, including but not limited to, integrated digital loop carrier or universal digital loop carrier systems; or has deployed any other system in which fiber optic facilities replace copper facilities in the distribution section (e.g., end office to remote terminal, pedestal or environmentally controlled vault);
 - 3.2.6.2 There are no spare copper loops capable of supporting the xDSL services the CLEC seeks to offer;
 - 3.2.6.3 BellSouth has not permitted the CLEC to deploy a Digital Subscriber Line Access Multiplexer at the remote terminal, pedestal or environmentally controlled vault or other interconnection point, nor has the CLEC obtained a virtual collocation arrangement at these sub-loop interconnection points as defined by 47 C.F.R. § 51.319 (b); and
 - 3.2.6.4 BellSouth has deployed packet switching capability for its own use.

3.3 Interoffice Transmission Facilities

BellSouth shall provide nondiscriminatory access, in accordance with FCC Rule 51.311 and Section 251(c)(3) of the Act, to interoffice transmission facilities on an unbundled basis to the CLEC for the provision of a telecommunications service.

3.4 Rates

The prices that the CLEC shall pay to BellSouth for Network Elements and Other Services are set forth in Attachment A to the SGAT.

3.5 Operational Support Systems (OSS)

The rates for access to OSS are as set forth in Attachment A to the SGAT.

4. Unbundled Network Element Combinations (Switched)

4.1 Port/Loop Combinations

4.1.1 At the CLEC's request, BellSouth shall provide access to combinations of port and loop network elements, as set forth in Section 4.1.3 below, that are Currently Combined in BellSouth's network except as specified in Sections 4.1.1.1 and 4.1.1.2 below.

4.1.1.1 BellSouth shall not provide combinations of port and loop network elements on an unbundled basis in locations where, pursuant to FCC rules, BellSouth is not required to provide circuit switching as an unbundled network element.

4.1.1.2 In accordance with effective and applicable FCC rules, BellSouth shall not be required to provide circuit switching as an unbundled network element in density Zone 1, as defined in 47 C.F.R. 69.123 as of January 1, 1999 of the Atlanta, GA; Miami, FL; Orlando, FL; Ft. Lauderdale, FL; Charlotte-Gastonia-Rock Hill, NC; Greensboro-Winston Salem-High Point, NC; Nashville, TN; and New Orleans, LA, MSAs to the CLEC if the CLEC's customer has 4 or more DS0 equivalent lines.

4.1.2 Combinations of port and loop network elements provide local exchange service for the origination or termination of calls. BellSouth shall make available the following loop and port combinations under the terms set forth below:

4.1.2.1 In Georgia and Kentucky, BellSouth shall provide to the CLEC combinations of port and loop network elements on an unbundled basis except in those locations where BellSouth is not required to provide circuit switching, as set forth in Section 4.1.1.2 above. BellSouth also provides CLECs combinations of network elements that are ordinarily combined in its network, in the manner in which they are typically combined, allowing CLECs to order combinations of typically combined elements even if the particular elements being ordered are not actually physically connected at

the time the order is placed. The rates for such combinations shall be the cost-based rates set forth in Attachment A.

- 4.1.2.2 In all other states, BellSouth shall provide to the CLEC combinations of port and loop network elements on an unbundled basis if such combinations are Currently Combined, except in those locations where BellSouth is not required to provide unbundled circuit switching, as forth in Sections 4.1.1.1 and 4.1.1.2 above. The rates for such combinations shall be the cost-based rates set forth in Attachment A.
- 4.1.2.3 In all states other than Georgia and Kentucky, except in those locations where BellSouth is not required to provide unbundled circuit switching, as set forth in Sections 4.1.1.1 and 4.1.1.2, BellSouth shall provide to the CLEC combinations of port and loop network elements that are not Currently Combined. The rate for such combinations may be requested through the bona fide request process.
- 4.1.3 Combination Offerings
 - 4.1.3.1 2-wire voice grade port, voice grade loop, unbundled end office switching, unbundled end office trunk port, common transport per mile per MOU, common transport facilities termination, tandem switching, and tandem trunk port.
 - 4.1.3.2 2-wire voice grade DID port, voice grade loop, unbundled end office switching, unbundled end office trunk port, common transport per mile per MOU, common transport facilities termination, tandem switching, and tandem trunk port.
 - 4.1.3.3 2-wire CENTREX port, voice grade loop, unbundled end office switching, unbundled end office trunk port, common transport per mile per MOU, common transport facilities termination, tandem switching, and tandem trunk port.
 - 4.1.3.4 2-wire ISDN Basic Rate Interface, voice grade loop, unbundled end office switching, unbundled end office trunk port, common transport per mile per MOU, common transport facilities termination, tandem switching, and tandem trunk port.
 - 4.1.3.5 4-wire ISDN Primary Rate Interface, DS1 loop, unbundled end office switching, unbundled end office trunk port, common transport per mile per MOU, common transport facilities termination, tandem switching, and tandem trunk port.
 - 4.1.3.6 4-wire DS1 Trunk port, DS1 Loop, unbundled end office switching, unbundled end office trunk port, common transport per mile per MOU,

common transport facilities termination, tandem switching, and tandem trunk port.

4.1.3.7 4-wire DS1 Loop with Channelization with Port, unbundled end office switching, unbundled end office trunk port, common transport per mile per MOU, common transport facilities termination, tandem switching, and tandem trunk port.

4.2 Assembly Points

4.2.1 Assembly Points are offered to provide CLECs the ability to combine unbundled network elements themselves within a BellSouth central office location, without requiring the CLEC to own or control any telecommunications equipment. The assembly products will be offered for three service types:

- DS0 Assembly Point (immediate deployment)
- DS1 Assembly Point (immediate deployment)
- DS3 Assembly Point (future deployment)

4.2.2 Assembly Points will provide access to 2-wire and 4-wire DS0 unbundled network elements for CLECs to combine two network elements at a cross-connect point (Assembly Point) designated by BellSouth. Subject to technical feasibility on a per location basis, BellSouth will offer access to DS1 and DS3 unbundled network elements at the designated DS1 or DS3 Assembly Point, respectively. BellSouth will supply all equipment required to access the unbundled elements. CLECs must supply any jumpers or patch cords to connect two elements at the Assembly Point and will not be permitted to install any equipment within the Assembly Point location. The CLEC may not install any equipment within the Assembly Point area. The CLEC may utilize portable test equipment for the purposes of testing unbundled network elements, but may not store this portable test equipment in the Assembly Point area.

4.2.3 The CLEC must submit an Application and an application fee for access to an Assembly Point. The CLEC must designate on its Assembly Point Application a forecast for a two-year period, designated by year. BellSouth will size the Assembly Point(s) according to forecast projections and will assign and designate facilities on a per request basis.

5. Operator Systems

5.1 Definition

BellSouth provides access to Operator Systems for operator and automated call handling and billing, special services, customer telephone listings and optional call completion services. The Operator Systems, provides two types of functions: Operator Service functions and Directory Assistance Service functions, each of which are described in detail below.

5.2 Operator Service

5.2.1 Definition

Operator Service provides: (1) operator handling for call completion (for example, collect, third number billing, and manual credit card calls), (2) operator or automated assistance for billing after the customer has dialed the called number (for example, credit card calls); and (3) special services including but not limited to Busy Line Verification and Emergency Line Interrupt (ELI), Emergency Agency Call, Operator-assisted Directory Assistance, and Rate Quotes.

5.2.2 Requirements

5.2.2.1 When the CLEC requests BellSouth to provide Operator Services, the following requirements apply:

5.2.2.1.1 BellSouth shall complete 0+ and 0- dialed local calls.

5.2.2.1.2 BellSouth shall complete 0+ intraLATA toll calls.

5.2.2.1.3 BellSouth shall complete calls that are billed to a CLEC customer's calling card that can be validated by BellSouth.

5.2.2.1.4 BellSouth shall complete person-to-person calls.

5.2.2.1.5 BellSouth shall complete collect calls.

5.2.2.1.6 BellSouth shall provide the capability for callers to bill to a third party and complete such calls.

5.2.2.1.7 BellSouth shall complete station-to-station calls.

5.2.2.1.8 BellSouth shall process emergency calls.

5.2.2.1.9 BellSouth shall process Busy Line Verify and Emergency Line Interrupt requests.

5.2.2.1.10 BellSouth shall process emergency call trace, as they do for their Customers prior to the Effective Date. Call must originate from a 911 provider.

5.2.2.1.11 BellSouth shall process operator-assisted directory assistance calls.

- 5.2.2.1.12 BellSouth will provide the ability for a CLEC Customer to reach a "live" operator on a 0-call.
- 5.2.2.2 BellSouth shall adhere to equal access requirements, providing the CLEC's local customers the same IXC access as provided to BellSouth customers.
- 5.2.2.3 BellSouth shall exercise at least the same level of fraud control in providing Operator Service to the CLEC that BellSouth provides for its own operator service.
- 5.2.2.4 BellSouth shall perform Billed Number Screening when handling Collect, Person-to-Person, and Billed-to-Third-Party calls.
- 5.2.2.5 BellSouth shall direct customer account and other similar inquiries to the customer service center designated by the CLEC.
- 5.2.2.6 BellSouth shall provide an electronic feed of customer call records in "EMR" format to the CLEC in accordance with the time schedule designated by the CLEC.

5.2.3 Interface Requirements:

With respect to Operator Services for calls that originate on local switching capability provided by or on behalf of the CLEC, the interface requirements shall conform to the then current established system interface specifications for the platform used to provide Operator Service and the interface shall conform to industry standards.

5.3 Directory Assistance Service

5.3.1 Definition

Directory Assistance Service provides local customer telephone number listings with the option to complete the call at the callers direction separate and distinct from local switching.

5.3.2 Requirements

- 5.3.2.1 Directory Assistance Service shall provide up to two listing requests per call. If available and if requested by the CLEC's customer, BellSouth shall provide caller-optional directory assistance call completion service to one of the provided listings, equal to that which BellSouth provides its customers. If not available, the CLEC may request such requirement pursuant to the Bona Fide Request Process.

5.3.2.2 Directory Assistance Service Updates

- 5.3.2.2.1 BellSouth shall update customer listings changes daily. These changes include:
 - 5.3.2.2.1.1 New customer connections: BellSouth will provide service to the CLEC that is equal to the service it provides to itself and its customers;
 - 5.3.2.2.1.2 Customer disconnections: BellSouth will provide service to the CLEC that is equal to the service it provides to itself and its customers; and
 - 5.3.2.2.1.3 Customer address changes: BellSouth will provide service to the CLEC that is equal to the service it provides to itself and its customers;
- 5.3.2.3 These updates shall also be provided for non-listed and non-published numbers for use in emergencies.

6. Common Transport

6.1 Definition

Common Transport is an interoffice transmission path between BellSouth Network Elements (illustrated in Figure 2). Where BellSouth Network Elements are connected by intra-office wiring, such wiring is not provided as a part of the Network Elements. Common Transport consists of BellSouth inter-office transport facilities and is unbundled from local switching.



Figure 2

6.2 Technical Requirements

- 6.2.1 Common Transport provided on DS1 or VT1.5 circuits, shall, at a minimum, meet the performance, availability, jitter, and delay requirements specified for Central Office to Central Office "CO to CO" connections in the technical reference set forth in Section 9.2.4.31 of this Attachment 2.
- 6.2.2 Common Transport provided on DS3 circuits, STS-1 circuits, and higher transmission bit rate circuits, Common Transport shall, at a minimum,

meet the performance, availability, jitter, and delay requirements specified for Central Office to Central Office "CO to CO" connections in the technical reference set forth in Section 9.2.4.30 of this Attachment 2.

- 6.2.3 BellSouth shall be responsible for the engineering, provisioning, and maintenance of the underlying equipment and facilities that are used to provide Common Transport.
- 6.2.4 At a minimum, Common Transport shall meet all of the requirements set forth in the following technical references (as applicable for the transport technology being used):
 - 6.2.4.1 ANSI T1.101-1994, American National Standard for Telecommunications - Synchronization Interface Standard Performance and Availability;
 - 6.2.4.2 ANSI T1.102-1993, American National Standard for Telecommunications - Digital Hierarchy - Electrical Interfaces;
 - 6.2.4.3 ANSI T1.102.01-199x, American National Standard for Telecommunications - Digital Hierarchy - VT1.5;
 - 6.2.4.4 ANSI T1.105-1995, American National Standard for Telecommunications - Synchronous Optical Network (SONET) - Basic Description including Multiplex Structure, Rates and Formats;
 - 6.2.4.5 ANSI T1.105.01-1995, American National Standard for Telecommunications - Synchronous Optical Network (SONET) - Automatic Protection Switching;
 - 6.2.4.6 ANSI T1.105.02-1995, American National Standard for Telecommunications - Synchronous Optical Network (SONET) - Payload Mappings;
 - 6.2.4.7 ANSI T1.105.03-1994, American National Standard for Telecommunications - Synchronous Optical Network (SONET) - Jitter at Network Interfaces;
 - 6.2.4.8 ANSI T1.105.03a-1995, American National Standard for Telecommunications - Synchronous Optical Network (SONET): Jitter at Network Interfaces - DS1 Supplement;
 - 6.2.4.9 ANSI T1.105.05-1994, American National Standard for Telecommunications - Synchronous Optical Network (SONET) - Tandem Connection;
 - 6.2.4.10 ANSI T1.105.06-199x, American National Standard for Telecommunications - Synchronous Optical Network (SONET) - Physical Layer Specifications;

- 6.2.4.11 ANSI T1.105.07-199x, American National Standard for Telecommunications - Synchronous Optical Network (SONET) - Sub STS-1 Interface Rates and Formats;
- 6.2.4.12 ANSI T1.105.09-199x, American National Standard for Telecommunications - Synchronous Optical Network (SONET) - Network Element Timing and Synchronization;
- 6.2.4.13 ANSI T1.106-1988, American National Standard for Telecommunications - Digital Hierarchy - Optical Interface Specifications (Single Mode);
- 6.2.4.14 ANSI T1.107-1988, American National Standard for Telecommunications - Digital Hierarchy - Formats Specifications;
- 6.2.4.15 ANSI T1.107a-1990 - American National Standard for Telecommunications - Digital Hierarchy - Supplement to Formats Specifications (DS3 Format Applications);
- 6.2.4.16 ANSI T1.107b-1991 - American National Standard for Telecommunications - Digital Hierarchy - Supplement to Formats Specifications;
- 6.2.4.17 ANSI T1.117-1991, American National Standard for Telecommunications - Digital Hierarchy - Optical Interface Specifications (SONET) (Single Mode - Short Reach);
- 6.2.4.18 ANSI T1.403-1989, Carrier to Customer Installation, DS1 Metallic Interface Specification;
- 6.2.4.19 ANSI T1.404-1994, Network-to-Customer Installation - DS3 Metallic Interface Specification;
- 6.2.4.20 ITU Recommendation G.707, Network node interface for the synchronous digital hierarchy (SDH);
- 6.2.4.21 ITU Recommendation G.704, Synchronous frame structures used at 1544, 6312, 2048, 8488 and 44736 kbit/s hierarchical levels;
- 6.2.4.22 Bellcore FR-440 and TR-NWT-000499, Transport Systems Generic Requirements (TSGR): Common Requirements;
- 6.2.4.23 Bellcore GR-820-CORE, Generic Transmission Surveillance: DS1 & DS3 Performance;
- 6.2.4.24 Bellcore GR-253-CORE, Synchronous Optical Network Systems (SONET); Common Generic Criteria;

- 6.2.4.25 Bellcore TR-NWT 000507, Transmission, Section 7, Issue 5 (Bellcore, December 1993). (A module of LSSGR, FR-NWT-000064.);
- 6.2.4.26 Bellcore TR-NWT-000776, Network Interface Description for ISDN Customer Access;
- 6.2.4.27 Bellcore TR-INS-000342, High-Capacity Digital Special Access Service-Transmission Parameter Limits and Interface Combinations, Issue 1 February 1991;
- 6.2.4.28 Bellcore ST-TEC 000052, Telecommunications Transmission Engineering Textbook, Volume 2: Facilities, Third Edition, Issue I May 1989;
- 6.2.4.29 Bellcore ST-TEC-000051, Telecommunications Transmission Engineering Textbook Volume 1: Principles, Third Edition. Issue 1 August 1987;

7. Dedicated Transport

7.1 Definition

- 7.1.1.1 Dedicated transport that provide telecommunications between wire centers or switches owned by BellSouth, or between wire centers and switches owned by BellSouth and the CLEC to a particular customer.
- 7.1.1.2 Unbundled Local Channel
- 7.1.1.3 Unbundled Local Channel is the dedicated transmission path between the CLEC's Point of Presence and the BellSouth Serving Wire Center's collocation.
- 7.1.1.4 Unbundled Interoffice Channel.
- 7.1.1.5 Unbundled Interoffice Channel is the dedicated transmission path that provides telecommunication between BellSouth's Serving Wire Centers' collocations.
- 7.1.2 BellSouth shall offer Dedicated Transport in each of the following ways:
 - 7.1.2.1 As capacity on a shared circuit.
 - 7.1.2.2 As a circuit (e.g., DS1, DS3, STS-1) dedicated to the CLEC. This circuit shall consist of an Unbundled Local Channel or an Unbundled Interoffice Channel or both.
- 7.1.3 When Dedicated Transport is provided it shall include (as appropriate):

- 7.1.3.1 Transmission equipment such as line terminating equipment, amplifiers, and regenerators;
- 7.1.3.2 Inter-office transmission facilities such as optical fiber, copper twisted pair, and coaxial cable.

7.2 Technical Requirements

This Section sets forth technical requirements for all Dedicated Transport.

- 7.2.1 When BellSouth provides Dedicated Transport as a circuit or a system, the entire designated transmission circuit or system (e.g., DS1, DS3, STS-1) shall be dedicated to CLEC designated traffic.
- 7.2.2 BellSouth shall offer Dedicated Transport in all technologies that become available including but not limited to, (1) DS0, DS1 and DS3 transport systems, and SONET point-to-point transport systems (including linear add-drop systems), at available transmission bit rates.
- 7.2.3 For DS1 or VT1.5 circuits, Dedicated Transport shall, at a minimum, meet the performance, availability, jitter, and delay requirements specified for Customer Interface to Central Office "CI to CO" connections in the industry standards.
- 7.2.4 Where applicable, for DS3 circuits, Dedicated Transport shall, at a minimum, meet the performance, availability, jitter, and delay requirements specified for Customer Interface to Central Office "CI to CO" connections in the technical references set forth in the industry standards.
- 7.2.5 When requested by the CLEC, Dedicated Transport shall provide physical diversity. Physical diversity means that two circuits are provisioned in such a way that no single failure of facilities or equipment will cause a failure on both circuits.
- 7.2.6 BellSouth shall offer the following interface transmission rates for Dedicated Transport:
 - 7.2.6.1 DS0 Equivalent;
 - 7.2.6.2 DS1 (Extended SuperFrame – ESF);
 - 7.2.6.3 DS3 (signal must be framed);
 - 7.2.6.4 SDH (Synchronous Digital Hierarchy) Standard interface rates in accordance with International Telecommunications Union (ITU) Recommendation G.707 and Plesiochronous Digital Hierarchy (PDH) rates per ITU Recommendation G.704.

7.2.6.5 When Dedicated Transport is provided, BellSouth shall design it according to BellSouth's network infrastructure to allow for the termination points specified by the CLEC.

7.3 Unbundled Channelization

7.3.1 BellSouth agrees to offer access to Unbundled Channelization when available pursuant to following terms and conditions and at the rates set forth in Attachment A to the SGAT.

7.3.2 Definition

7.3.3 Unbundled Channelization (UC) provides the multiplexing capability that will allow a DS1 (1.544 Mbps) or DS3 (44.736 Mbps) or STS-1 Unbundled Network Element (UNE) or collocation cross-connect to be multiplexed or channelized at a BellSouth central office. This can be accomplished through the use of a stand-alone multiplexer or a digital cross-connect system at the discretion of BellSouth. Once UC has been installed, the CLEC can have channels activated on an as-needed basis by having BellSouth connect lower level UNEs via Central Office Channel Interfaces (COCI).

7.3.3.1.1 Channelization capabilities will be as follows:

7.3.3.2 DS3 Channelization System: An element that channelizes a DS3 signal into 28 DS1s/STS-1s

7.3.3.3 DS1 Channelization System: An element that channelizes a DS1 signal into 24 DS0s.

7.3.3.4 Central Office Channel Interfaces (COCI): Elements that can be activated on a channelization system.

7.3.3.5 DS1 Central Office Channel Interface elements can be activated on a DS3 Channelization System.

7.3.4 Voice Grade and Digital Data Central Office Channel Interfaces can be activated on a DS1 Channelization System.

7.3.5 AMI and B8ZS line coding with either Super Frame (SF) and Extended Super Frame (ESF) framing formats will be supported as options.

- 7.3.6 COCI will be billed on the lower level UNE order that is interfacing with the UC arrangement and will have to be compatible with those UNEs.
- 7.3.7 Channelization may be incorporated within dedicated transport or ordered as a stand-alone capability, which requires either the high or low speed side to be connected to collocation.

8.0 Combinations (Non-Switched)

- 8.1 For purposes of this Section, references to “Currently Combined” network elements shall mean that such network elements are in fact already combined by BellSouth in the BellSouth network to provide service to a particular location.
- 8.2 EELs.
 - 8.2.1 Where facilities permit and where necessary to comply with an effective FCC and/or State Commission order, or where BellSouth chooses, BellSouth shall offer access to loop and transport combinations, also known as the Enhanced Extended Link (“EEL”) as defined in Section 4.3 below.
 - 8.2.2 Subject to Section 8.2.3 below, BellSouth will provide access to the EEL in the combinations set forth in 8.3 following. This offering is intended to provide connectivity from an end user’s location through that end user’s SWC to the CLEC’s POP serving wire center. The circuit must be connected to the CLEC’s switch for the purpose of provisioning telephone exchange service to the CLEC’s end-user customers. The EEL will be connected to the CLEC’s facilities in the CLEC’s collocation space at the POP SWC, or the CLEC may purchase BellSouth’s access facilities between the CLEC’s POP and the CLEC’s collocation space at the POP SWC.
 - 8.2.3 BellSouth shall provide EEL combinations to CLECs in the states of Georgia and Kentucky for combinations of network elements that are ordinarily combined in its network, in the manner which they are typically combined, allowing CLECs to order combinations of typically combined elements even if the particular elements being ordered are not actually physically connected at the time the order is placed. In all other states, BellSouth shall make available to the CLEC those EEL combinations described in Section 8.3 below only to the extent such combinations are Currently Combined. Furthermore, BellSouth will make available EEL combinations to the CLEC in density Zone 1, as defined in 47 C.F.R.

69.123 as of January 1, 1999, in Miami, Orlando, Fort Lauderdale, Charlotte, New Orleans, Greensboro and Nashville MSAs, regardless of whether or not such EELs are Currently Combined. Except as stated above, EELs will be provided to the CLEC only to the extent such network elements are Currently Combined.

8.2.4 Additionally, BellSouth shall make available to the CLEC a combination of an unbundled loop and special access interoffice facilities. To the extent the CLEC will require multiplexing functionality in connection with such combination, BellSouth will provide access to multiplexing within the central office pursuant to the terms, conditions and rates set forth in its Access Services Tariffs. Where multiplexing functionality is required in connection with loop and transport combinations, such multiplexing will be provided under the terms set forth in this Attachment and at the rates set forth in Attachment A to the SGAT.

8.3 EEL Combinations

8.3.1 DS1 Interoffice Channel + DS1 Channelization + 2-wire VG Local Loop

8.3.2 DS1 Interoffice Channel + DS1 Channelization + 4-wire VG Local Loop

8.3.3 DS1 Interoffice Channel + DS1 Channelization + 2-wire ISDN Local Loop

8.3.4 DS1 Interoffice Channel + DS1 Channelization + 4-wire 56 kbps Local Loop

8.3.5 DS1 Interoffice Channel + DS1 Channelization + 4-wire 64 kbps Local Loop

8.3.6 DS1 Interoffice Channel + DS1 Local Loop

8.3.7 DS3 Interoffice Channel + DS3 Local Loop

8.3.8 STS-1 Interoffice Channel + STS-1 Local Loop

8.3.9 DS3 Interoffice Channel + DS3 Channelization + DS1 Local Loop

8.3.10 STS-1 Interoffice Channel + DS3 Channelization + DS1 Local Loop

8.3.11 2-wire VG Interoffice Channel + 2-wire VG Local Loop

8.3.12 4-wire VG Interoffice Channel + 4-wire VG Local Loop

8.3.13 4-wire 56 kbps Interoffice Channel + 4-wire 56 kbps Local Loop

8.3.14 4-wire 64 kbps Interoffice Channel + 4-wire 64 kbps Local Loop

8.4 Other Network Element Combinations

BellSouth shall make available to the CLEC, in accordance with Section 8.6 below, combinations of network elements other than EELs only to the extent such combinations are Currently Combined.

8.5 Special Access Service Conversions

8.5.1 The CLEC may not convert special access services to combinations of loop and transport network elements, whether or not the CLEC self-provides its entrance facilities (or obtains entrance facilities from a third party), unless the CLEC uses the combination to provide a significant amount of local exchange service, in addition to exchange access service, to a particular customer. To the extent the CLEC converts its special access services to combinations of loop and transport network elements at UNE prices, the CLEC, hereby, certifies that it is providing a significant amount of local exchange service over such combinations. BellSouth may, at its sole discretion, audit the CLEC records in order to verify the type of traffic being transmitted over combinations of loop and transport network elements. If, based on its audits, BellSouth concludes that the CLEC is not providing a significant amount of local exchange traffic over the combinations of loop and transport network elements, BellSouth may file a complaint with the appropriate Commission, pursuant to the dispute resolution process as set forth in the Interconnection Agreement. In the event that BellSouth prevails, BellSouth may convert such combinations of loop and transport network elements to special access services and may seek appropriate retroactive reimbursement from the CLEC.

8.5.2 EEL combinations for DS1 level and above will be available only when the CLEC provides and handles at least one third of the end user's local traffic over the facility provided. In addition, on the DS1 loop portion of the combination, at least fifty (50) percent of the activated channels must have at least five (5) percent local voice traffic individually and, for the entire DS1 facility, at least ten (10) percent of the traffic must be local voice traffic.

8.5.3 When combinations of loop and transport network elements include multiplexing, each of the individual DS1 circuits must meet the above criteria.

8.5.4 The three circumstances under which a requesting carrier can meet the significant local traffic criteria are set forth in paragraph 22 of the FCC's Supplemental Order Clarification in Docket No. CC 96-98 dated June 2,

2000.

8.6 Rates

8.6.1 Subject to Section 8.2.3 and 8.4 preceding, the non-recurring and recurring rates for the EEL combinations set forth in Section 8.3 and other Currently Combined network elements are set forth in Attachment A to the SGAT.

9. Signaling Link Transport

9.1 Definition

Signaling Link Transport is a set of two or four dedicated 56 Kbps. transmission paths between CLEC-designated Signaling Points of Interconnection (SPOI) that provides appropriate physical diversity.

9.2 Technical Requirements

9.2.1 Signaling Link Transport shall consist of full duplex mode 56 kbps transmission paths.

9.2.2 Of the various options available, Signaling Link Transport shall perform in the following two ways:

9.2.2.1 As an "A-link" which is a connection between a switch or SCP and a home Signaling Transfer Point Switch (STPS) pair; and

9.2.2.2 As a "B-link" which is a connection between two STPS pairs in different company networks (e.g., between two STPS pairs for two CLECs.

9.2.3 Signaling Link Transport shall consist of two or more signaling link layers as follows:

9.2.3.1 An A-link layer shall consist of two links.

9.2.3.2 A B-link layer shall consist of four links.

9.2.4 A signaling link layer shall satisfy a performance objective such that:

9.2.4.1 There shall be no more than two minutes down time per year for an A-link layer; and

9.2.4.2 There shall be negligible (less than 2 seconds) down time per year for a B-link layer.

9.2.5 A signaling link layer shall satisfy interoffice and intraoffice diversity of facilities and equipment, such that:

- 9.2.5.1 No single failure of facilities or equipment causes the failure of both links in an A-link layer (i.e., the links should be provided on a minimum of two separate physical paths end-to-end); and
- 9.2.5.2 No two concurrent failures of facilities or equipment shall cause the failure of all four links in a B-link layer (i.e., the links should be provided on a minimum of three separate physical paths end-to-end).

9.3 Interface Requirements

- 9.3.1 There shall be a DS1 (1.544 Mbps) interface at the CLEC-designated SPOIs. Each 56 kbps transmission path shall appear as a DS0 channel within the DS1 interface.

10. Signaling Transfer Points (STPs)

- 10.1 Definition - Signaling Transfer Points is a signaling network function that includes all of the capabilities provided by the signaling transfer point switches (STPSs) and their associated signaling links which enable the exchange of SS7 messages among and between switching elements, database elements and signaling transfer point switches. Figure 4 depicts Signaling Transfer Points.

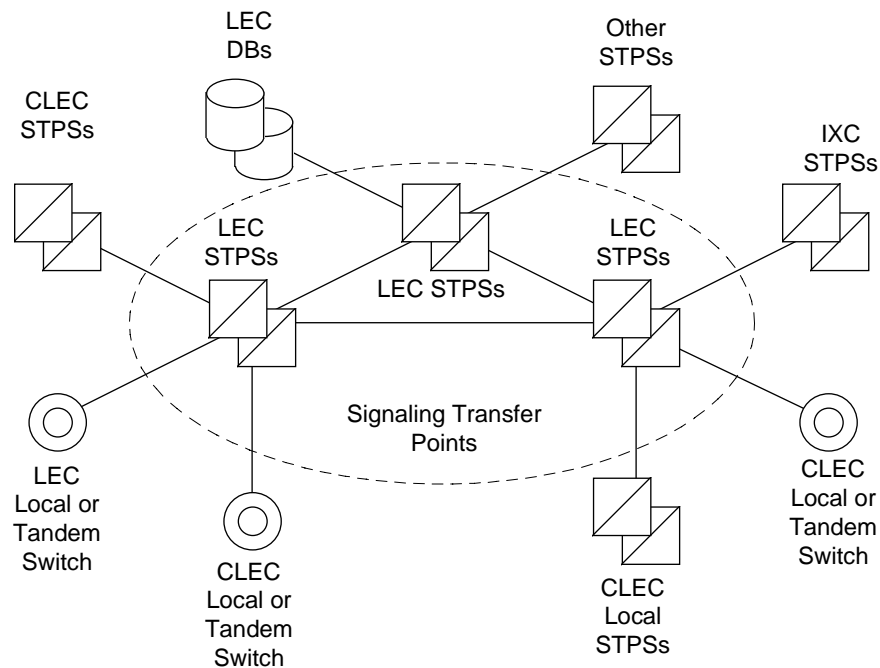

Figure 4

10.2 Technical Requirements

- 10.2.1 STPs shall provide access to Network Elements connected to BellSouth SS7 network. These include:
 - 10.2.1.1 BellSouth Local Switching or Tandem Switching;
 - 10.2.1.2 BellSouth Service Control Points/DataBases;
 - 10.2.1.3 Third-party local or tandem switching
 - 10.2.1.4 Third-party-provided STPSs.
- 10.2.2 The connectivity provided by STPs shall fully support the functions of all other Network Elements connected to BellSouth SS7 network. This explicitly includes the use of BellSouth SS7 network to convey messages which neither originate nor terminate at a signaling end point directly connected to BellSouth SS7 network (*i.e.*, transient messages). When BellSouth SS7 network is used to convey transient messages, there shall be no alteration of the Integrated Services Digital Network User Part (ISDNUP) or Transaction Capabilities Application Part (TCAP) user data that constitutes the content of the message.
- 10.2.3 If a BellSouth tandem switch routes calling traffic, based on dialed or translated digits, on SS7 trunks between a CLEC local switch and third party local switch, BellSouth SS7 network shall convey the TCAP messages that are necessary to provide Call Management features (Automatic Callback, Automatic Recall, and Screening List Editing) between the CLEC local STPSs and the STPSs that provide connectivity with the third party local switch, even if the third party local switch is not directly connected to BellSouth STPSs.
- 10.2.4 STPs shall provide all functions of the MTP as defined in Bellcore ANSI Interconnection Requirements. This includes:
 - 10.2.4.1 Signaling Data Link functions, as defined in Bellcore ANSI Interconnection Requirements,
 - 10.2.4.2 Signaling Link functions, as defined in Bellcore ANSI Interconnection Requirements, and
 - 10.2.4.3 Signaling Network Management functions, as defined in Bellcore ANSI Interconnection Requirements.
- 10.2.5 STPs shall provide all functions of the SCCP necessary for Class 0 (basic connectionless) service, as defined in Bellcore ANSI Interconnection Requirements. In particular, this includes Global Title Translation (GTT) and SCCP Management procedures, as specified in T1.112.4. In cases where the destination signaling point is a BellSouth local or tandem

switching system or data base, or is a CLEC or third party local or tandem switching system directly connected to BellSouth SS7 network, STPs shall perform final GTT of messages to the destination and SCCP Subsystem Management of the destination. In all other cases, STPs shall perform intermediate GTT of messages to a gateway pair of STPSs in an SS7 network connected with BellSouth SS7 network, and shall not perform SCCP Subsystem Management of the destination.

- 10.2.6 STPs shall also provide the capability to route SCCP messages based on ISNI, as defined in Bellcore ANSI Interconnection Requirements, when this capability becomes available on BellSouth STPSs.
- 10.2.7 STPs shall provide on a non-discriminatory basis all functions of the OMAP commonly provided by STPSs. All OMAP functions will be on a "where available" basis and can include:
 - 10.2.7.1 MTP Routing Verification Test (MRVT) and
 - 10.2.7.2 SCCP Routing Verification Test (SRVT).
- 10.2.8 In cases where the destination signaling point is a BellSouth local or tandem switching system or database, or is a CLEC or third party local or tandem switching system directly connected to the BellSouth SS7 network, STPs shall perform MRVT and SRVT to the destination signaling point. In all other cases, STPs shall perform MRVT and SRVT to a gateway pair of STPSs in an SS7 network connected with the BellSouth SS7 network. This requirement shall be superseded by the specifications for Internetwork MRVT and SRVT if and when these become approved ANSI standards and available capabilities of BellSouth STPSs, and if mutually agreed upon by the CLEC and BellSouth.
- 10.2.9 STPs shall be equal to or better than the following performance requirements:
 - 10.2.9.1 MTP Performance, as defined in Bellcore ANSI Interconnection Requirements and
 - 10.2.9.2 SCCP Performance, as defined in Bellcore ANSI Interconnection Requirements.
- 10.2.10 SS7 Advanced Intelligent Network (AIN) Access**
 - 10.2.10.1 SS7 AIN Access shall provide the CLEC SCP access to BellSouth local switch via interconnection of BellSouth SS7 and CLEC SS7 Networks. BellSouth shall offer SS7 access through its STPs. If BellSouth requires a mediation device on any part of its network, BellSouth must route its calls in the same manner. The interconnection arrangement shall result in the

BellSouth local switch recognizing the CLEC SCP as at least at parity with BellSouth's SCPs in terms of interfaces, performance and capabilities.

SS7 AIN Access is the provisioning of AIN triggers in a BellSouth local switch and interconnection of the BellSouth SS7 network with the CLEC SS7 network to exchange TCAP queries and responses with a CLEC SCP.

- 10.2.10.2 When provided through the same mediation application, delay associated with BellSouth local switch queries to the CLEC STP shall be equal to or shorter than the delay associated with queries to BellSouth STP.
- 10.2.10.3 BellSouth's STPs shall maintain global title translations necessary to direct AIN queries for select global title address and translation type values to the CLEC SS7 network.
- 10.2.10.4 BellSouth STPs shall route mutually agreeable AIN responses from the CLEC SCP via SS7 network interconnect to the local switch designated in the Signaling Connection Control Part (SCCP) called party address.
- 10.2.10.5 Network management controls resulting from an overload in elements not supporting the CLEC's customers shall not affect queries to the CLEC SCPs.
- 10.2.10.6 When the CLEC selects SS7 AIN Access, BellSouth will provide access to provisioning processes to support interconnection of the CLEC's STPs.
- 10.2.10.7 STPs shall offer SS7 AIN Access in accordance with the requirements of the following technical references, as implemented in BellSouth's STPs:
 - 10.2.10.7.1 GR-2863-CORE, CCS Network Interface Specification Supporting Advanced Intelligent Network (AIN); and
 - 10.2.10.7.2 GR-2902-CORE, CCS Network Interface Specification (CCSNIS) Supporting Toll-Free Service Using Advanced Intelligent Network (AIN).

10.3 Interface Requirements

- 10.3.1 BellSouth shall provide the following STPs options to connect the CLEC or the CLEC-designated local switching systems or STPs to BellSouth SS7 network:
 - 10.3.1.1 An A-link interface from the CLEC local switching systems; and,
 - 10.3.1.2 A B-link interface from the CLEC local STPs.

10.3.2 Each type of interface shall be provided by one or more sets (layers) of signaling links, as follows:

10.3.2.1 An A-link layer shall consist of two links, as depicted in Figure 6.

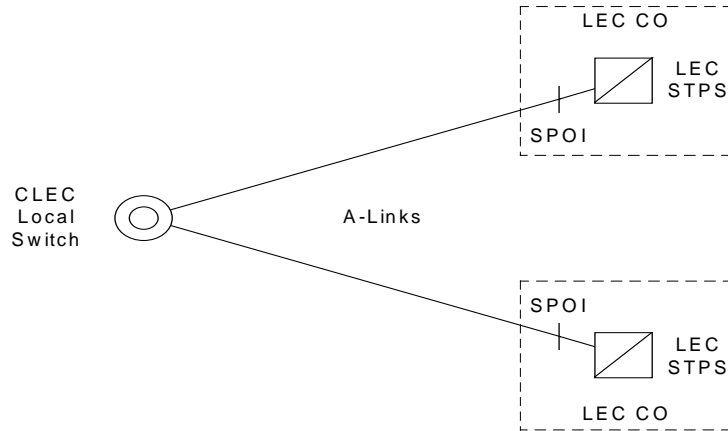

Figure 6. A-Link Interface

10.3.2.2 A B-link layer shall consist of four links, as depicted in Figure 7.

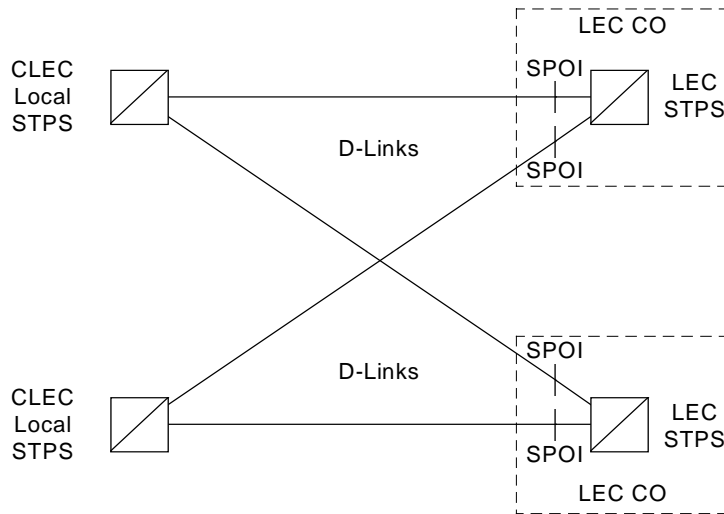

Figure 7. B-link Interface

10.3.3 The Signaling Point of Interconnection (SPOI) for each link shall be located at a cross-connect element, such as a DSX-1, in the Central Office (CO) where BellSouth STPS is located. There shall be a DS1 or

higher rate transport interface at each of the SPOIs. Each signaling link shall appear as a DS0 channel within the DS1 or higher rate interface. BellSouth shall offer higher rate DS1 signaling for interconnecting the CLEC local switching systems or STPSs with BellSouth STPSs as soon as these become approved ANSI standards and available capabilities of BellSouth STPSs. BellSouth and the CLEC will work jointly to establish mutually acceptable SPOIs.

10.3.4 BellSouth CO shall provide intraoffice diversity between the SPOIs and BellSouth STPS, so that no single failure of intraoffice facilities or equipment shall cause the failure of both B-links in a layer connecting to a BellSouth STPS. BellSouth and the CLEC will work jointly to establish mutually acceptable SPOIs.

10.3.5 BellSouth shall provide MTP and SCCP protocol interfaces that shall conform to all sections relevant to the MTP or SCCP in the following specifications:

10.3.5.1 Bellcore GR-905-CORE, Common Channel Signaling Network Interface Specification (CCSNIS) Supporting Network Interconnection, Message Transfer Part (MTP), and Integrated Services Digital Network User Part (ISDNUP);

10.3.5.2 Bellcore GR-1432-CORE, CCS Network Interface Specification (CCSNIS) Supporting Signaling Connection Control Part (SCCP) and Transaction Capabilities Application Part (TCAP).

10.3.6 Message Screening

10.3.6.1 BellSouth shall set message screening parameters so as to accept valid messages from the CLEC local or tandem switching systems destined to any signaling point within BellSouth's SS7 network where the CLEC switching system has a legitimate signaling relation.

10.3.6.2 BellSouth shall set message screening parameters so as to pass valid messages from the CLEC local or tandem switching systems destined to any signaling point or network accessed through BellSouth's SS7 network where the CLEC switching system has a legitimate signaling relation.

10.3.6.3 BellSouth shall set message screening parameters so as to accept and pass/send valid messages destined to and from the CLEC from any signaling point or network interconnected through BellSouth's SS7 network where the CLEC SCP has a legitimate signaling relation.

10.4 STPs shall be equal to or better than all of the requirements for STPs set forth in the following technical references:

- 10.4.1 ANSI T1.111-1992 American National Standard for Telecommunications - Signaling System Number 7 (SS7) - Message Transfer Part (MTP);
- 10.4.2 ANSI T1.111A-1994 American National Standard for Telecommunications - Signaling System Number 7 (SS7) - Message Transfer Part (MTP) Supplement;
- 10.4.3 ANSI T1.112-1992 American National Standard for Telecommunications - Signaling System Number 7 (SS7) - Signaling Connection Control Part (SCCP);
- 10.4.4 ANSI T1.115-1990 American National Standard for Telecommunications - Signaling System Number 7 (SS7) - Monitoring and Measurements for Networks;
- 10.4.5 ANSI T1.116-1990 American National Standard for Telecommunications - Signaling System Number 7 (SS7) - Operations, Maintenance and Administration Part (OMAP);
- 10.4.6 ANSI T1.118-1992 American National Standard for Telecommunications - Signaling System Number 7 (SS7) - Intermediate Signaling Network Identification (ISNI);
- 10.4.7 Bellcore GR-905-CORE, Common Channel Signaling Network Interface Specification (CCSNIS) Supporting Network Interconnection, Message Transfer Part (MTP), and Integrated Services Digital Network User Part (ISDNUP); and
- 10.4.8 Bellcore GR-1432-CORE, CCS Network Interface Specification (CCSNIS) Supporting Signaling Connection Control Part (SCCP) and Transaction Capabilities Application Part (TCAP).

11. Service Control Points/DataBases

11.1 Definition

- 11.1.1 Databases are the Network Elements that provide the functionality for storage of, access to, and manipulation of information required to offer a particular service and/or capability. Databases include, but are not limited to: Local Number Portability, LIDB, Toll Free Number Database, Automatic Location Identification/Data Management System, access to Service Creation Environment and Service Management System (SCE/SMS) application databases and Directory Assistance.
- 11.1.2 A Service Control Point (SCP) is a specific type of Database functionality deployed in a Signaling System 7 (SS7) network that executes service application logic in response to SS7 queries sent to it by a switching

system also connected to the SS7 network. Service Management Systems provide operational interfaces to allow for provisioning, administration and maintenance of subscriber data and service application data stored in SCPs.

11.2 Technical Requirements for SCPs/Databases

Requirements for SCPs/Databases within this section address storage of information, access to information (e.g. signaling protocols, response times), and administration of information (e.g., provisioning, administration, and maintenance). All SCPs/Databases shall be provided to the CLEC in accordance with the following requirements.

11.2.1 BellSouth shall provide physical interconnection to SCPs through the SS7 network and protocols, with TCAP as the application layer protocol.

11.2.2 BellSouth shall provide physical interconnection to databases via industry standard interfaces and protocols (e.g. ISDN and X.25).

11.2.3 The reliability of interconnection options shall be consistent with industry standards for diversity and survivability.

11.2.4 Database Availability

Call processing databases shall have a maximum unscheduled availability of 30 minutes per year. Unavailability due to software and hardware upgrades shall be scheduled during minimal usage periods and only be undertaken upon proper notification to providers which might be impacted. Any downtime associated with the provision of call processing related databases will impact all service providers, including BellSouth, equally.

11.2.5 The operational interface provided by BellSouth shall complete Database transactions (i.e., add, modify, delete) for the CLEC's customer records stored in BellSouth databases within 24 hours, or sooner where BellSouth provisions its own customer records within a shorter interval.

11.3 Local Number Portability Database

11.3.1 Definition

The Permanent Number Portability (PNP) database supplies routing numbers for calls involving numbers that have been ported from one local service provider to another.

11.4 Line Information Database (LIDB):

See Attachment F to the SGAT for LIDB terms and conditions.

11.5 Toll Free Number Database

The Toll Free Number Database is a SCP that provides functionality necessary for toll free (e.g., 800 and 888) number services by providing routing information and additional so-called vertical features during call set-up in response to queries from SSPs. BellSouth shall provide the Toll Free Number Database in accordance with the following:

11.5.1 Technical Requirements

- 11.5.1.1 BellSouth shall make BellSouth Toll Free Number Database available for the CLEC to query with a toll-free number and originating information.
- 11.5.1.2 The Toll Free Number Database shall return carrier identification and, where applicable, the queried toll free number, translated numbers and instructions as it would in response to a query from a BellSouth switch.
- 11.5.1.3 The SCP shall also provide, at the CLEC's option, such additional feature as described in SR-TSV-002275 (BOC Notes on BellSouth Networks, SR-TSV-002275, Issue 2, (Bellcore, April 1994)) as are available to BellSouth. These may include but are not limited to:
 - 11.5.1.3.1 Network Management;
 - 11.5.1.3.2 Customer Sample Collection; and
 - 11.5.1.3.3 Service Maintenance

11.5.2 Interface Requirements

The signaling interface between the CLEC or other local switch and the Toll-Free Number database shall use the TCAP protocol, together with the signaling network interface as specified in the technical reference herein.

11.6 Automatic Location Identification/Data Management System (ALI/DMS)

The ALI/DMS Database contains customer information (including name, address, telephone information, and sometimes special information from the local service provider or customer) used to determine to which Public Safety Answering Point (PSAP) to route the call. The ALI/DMS database is used to provide more routing flexibility for E911 calls than Basic 911. BellSouth shall provide the Emergency Services Database in accordance with the following:

11.6.1 Technical Requirements

- 11.6.1.1 BellSouth shall offer the CLEC a data link to the ALI/DMS database or permit the CLEC to provide its own data link to the ALI/DMS database. BellSouth shall provide error reports from the ALI/DMS database to the CLEC immediately after the CLEC inputs information into the ALI/DMS

data base. Alternately, the CLEC may utilize BellSouth, to enter customer information into the data base on a demand basis, and validate customer information on a demand basis.

- 11.6.1.2 The ALI/DMS database shall contain the following customer information:
 - 11.6.1.2.1 Name;
 - 11.6.1.2.2 Address;
 - 11.6.1.2.3 Telephone number; and
 - 11.6.1.2.4 Other information as appropriate (e.g., whether a customer is blind or deaf or has another disability).
- 11.6.1.3 When BellSouth is responsible for administering the ALI/DMS database in its entirety, ported number NXXs entries for the ported numbers should be maintained unless the CLEC requests otherwise and shall be updated if the CLEC requests, provided the CLEC supplies BellSouth with the updates.
- 11.6.1.4 If BellSouth is responsible for configuring PSAP features (for cases when the PSAP or BellSouth supports an ISDN interface) it shall ensure that CLASS Automatic Recall (Call Return) is not used to call back to the ported number. Although BellSouth currently does not have ISDN interface, BellSouth agrees to comply with this requirement once ISDN interfaces are in place.

11.6.2 Interface Requirements

The interface between the E911 Switch or Tandem and the ALI/DMS database for the CLEC's customers shall meet industry standards.

11.7 Directory Assistance Database

BellSouth shall make its directory assistance database available to the CLEC in order to allow the CLEC to provide its customers with the same directory assistance services BellSouth provides to BellSouth customers. BellSouth shall provide the CLEC with an initial feed via magnetic tape and daily update initially via magnetic tape and subsequently via an electronic gateway to be developed mutually by the CLEC and BellSouth of customer address and number changes. Directory Assistance Services must provide both the ported and CLEC telephone numbers to the extent available in BellSouth's database assigned to a customer. Privacy indicators must be properly identified to assure the non-published numbers are accurately identified.

- 11.8 SCPs/Databases shall be equal to or better than all of the requirements for SCPs/Databases set forth in the following technical references:

- 11.8.1 GR-246-CORE, Bell Communications Research Specification of Signaling System Number 7, ISSUE 1 (Bellcore, December 199);
- 11.8.2 GR-1432-CORE, CCS Network Interface Specification (CCSNIS) Supporting Signaling Connection Control Part (SCCP) and Transaction Capabilities Application Part (TCAP). (Bellcore, March 1994);
- 11.8.3 GR-954-CORE, CCS Network Interface Specification (CCSNIS) Supporting Line Information Database (LIDB) Service 6, Issue 1, Rev. 1 (Bellcore, October 1995);
- 11.8.4 GR-1149-CORE, OSSGR Section 10: System Interfaces, Issue 1 (Bellcore, October 1995) (Replaces TR-NWT-001149);
- 11.8.5 GR-1158-CORE, OSSGR Section 22.3: Line Information Database 6, Issue (Bellcore, October 1995);
- 11.8.6 GR-1428-CORE, CCS Network Interface Specification (CCSNIS) Supporting Toll Free Service (Bellcore, May 1995); and
- 11.8.7 BOC Notes on BellSouth Networks, SR-TSV-002275, ISSUE 2, (Bellcore, April 1994).
- 11.9 Service Creation Environment and Service Management System (SCE/SMS) Advanced Intelligent Network (AIN) Access
 - 11.9.1 BellSouth's Service Creation Environment and Service Management System (SCE/SMS) Advanced Intelligent Network (AIN) Access shall provide the CLEC the capability that will allow the CLEC and other third parties to create service applications in a BellSouth Service Creation Environment and deploy those applications in a BellSouth SMS to a BellSouth SCP. The third party service applications interact with AIN triggers provisioned on a BellSouth SSP.
 - 11.9.2 BellSouth's SCE/SMS AIN Access shall provide access to SCE hardware, software, testing and technical support (e.g., help desk, system administrator) resources available to the CLEC. Scheduling procedures shall provide the CLEC equivalent priority to these resources
 - 11.9.3 BellSouth SCP shall partition and protect the CLEC service logic and data from unauthorized access, execution or other types of compromise.
 - 11.9.4 When the CLEC selects SCE/SMS AIN Access, BellSouth shall provide training, documentation, and technical support to enable the CLEC to use BellSouth's SCE/SMS AIN Access to create and administer applications. Training, documentation, and technical support will address use of SCE

and SMS access and administrative functions, but will not include support for the creation of a specific service application.

- 11.9.5 When the CLEC selects SCE/SMS AIN Access, BellSouth shall provide for a secure, controlled access environment in association with its internal use of AIN components. CLEC access will be provided via remote data connection (e.g., dial-in, ISDN).
- 11.9.6 When the CLEC selects SCE/SMS AIN Access, BellSouth shall allow the CLEC to download data forms and/or tables to BellSouth SCP via BellSouth SMS without intervention from BellSouth (e.g., service customization and customer subscription).

12. Tandem Switching

12.1 Definition

Tandem Switching is the function that establishes a communications path between two switching offices through a third switching office (the tandem switch).

12.2 Technical Requirements

- 12.2.1 Tandem Switching shall have the same capabilities or equivalent capabilities as those described in Bell Communications Research TR-TSY-000540 Issue 2R2, Tandem Supplement, 6/1/90. The requirements for Tandem Switching include, but are not limited to the following:
 - 12.2.1.1 Tandem Switching shall provide signaling to establish a tandem connection;
 - 12.2.1.2 Tandem Switching will provide screening as jointly agreed to by the CLEC and BellSouth;
 - 12.2.1.3 Tandem Switching shall provide Advanced Intelligent Network triggers supporting AIN features where such routing is not available from the originating end office switch, to the extent such Tandem switch has such capability
 - 12.2.1.4 Tandem Switching shall provide access to Toll Free number portability database as designated by the CLEC;
 - 12.2.1.5 Tandem Switching shall provide all trunk interconnections discussed under the "Network Interconnection" section (e.g., SS7, MF, DTMF, DialPulse, PRI-ISDN, DID, and CAMA-ANI (if appropriate for 911));

- 12.2.1.6 Tandem Switching shall provide connectivity to PSAPs where 911 solutions are deployed and the tandem is used for 911; and
- 12.2.1.7 Where appropriate, Tandem Switching shall provide connectivity to transit traffic to and from other carriers.
- 12.2.2 Tandem Switching shall accept connections (including the necessary signaling and trunking interconnections) between end offices, other tandems, IECs, ICOs, CAPs and the CLEC's switches.
- 12.2.3 Tandem Switching shall provide local tandeming functionality between two end offices including two offices belonging to different CLECs (e.g., between a CLEC end office and the end office of another CLEC).
- 12.2.4 Tandem Switching shall preserve CLASS/LASS features and Caller ID as traffic is processed.
- 12.2.5 Tandem Switching shall record billable events and send them to the area billing centers designated by the CLEC. Tandem Switching will provide recording of all billable events as jointly agreed to by the CLEC and BellSouth.
- 12.2.6 Upon a reasonable request from the CLEC, BellSouth shall perform routine testing and fault isolation on the underlying switch that is providing Tandem Switching and all its interconnections. The results and reports of the testing shall be made immediately available to the CLEC.
- 12.2.7 BellSouth shall maintain the CLEC's trunks and interconnections associated with Tandem Switching at least at parity to its own trunks and interconnections.
- 12.2.8 BellSouth shall control congestion points and network abnormalities. All traffic will be restricted in a non discriminatory manner.
- 12.2.9 Tandem Switching shall route calls to BellSouth's or the CLEC's endpoints or platforms (e.g., operator services and PSAPs) on a per call basis as designated by the CLEC, where such routing is not available from the originating end office switch, to the extent such Tandem Switch has such capability. Detailed primary and overflow routing plans for all interfaces available within BellSouth switching network shall be mutually agreed to by the CLEC and BellSouth. Such plans shall meet the CLEC requirements for routing calls through the local network.
- 12.2.10 Tandem Switching shall process originating toll-free traffic received from a CLEC local switch.
- 12.2.11 In support of AIN triggers and features, Tandem Switching shall provide SSP capabilities when these capabilities are not available from the Local

Switching Network Element, to the extent such Tandem Switch has such capability.

12.3 Interface Requirements

- 12.3.1 Tandem Switching shall provide interconnection to the E911 PSAP where the underlying Tandem is acting as the E911 Tandem.
- 12.3.2 Tandem Switching shall interconnect, with direct trunks, to all carriers with which BellSouth interconnects.
- 12.3.3 BellSouth shall provide all signaling necessary to provide Tandem Switching with no loss of feature functionality.
- 12.3.4 Tandem Switching shall interconnect with the CLEC's switch, using two-way trunks, for traffic that is transiting via BellSouth network to interLATA or intraLATA carriers. At the CLEC's request, Tandem Switching shall record and keep records of traffic for billing.
- 12.3.5 Tandem Switching shall provide an alternate final routing pattern for the CLEC traffic overflowing from direct end office high usage trunk groups.
- 12.4 Tandem Switching shall meet or exceed (i.e., be more favorable to the CLEC) each of the requirements for Tandem Switching set forth in the following technical references:
 - 12.4.1 Bell Communications Research TR-TSY-000540 Issue 2R2, Tandem Supplement, 6/1/90;
 - 12.4.2 GR-905-CORE covering CCSNIS;
 - 12.4.3 GR-1429-CORE for call management features; and GR-2863-CORE and GR-2902-CORE covering CCS AIN interconnection

13. DARK FIBER:

13.1.1 Definition

Dark Fiber is unused strands of optical fiber without multiplexing, signal regeneration, aggregation or other electronics that connects two points within BellSouth's network. Dark Fiber also includes stands of optical fiber existing in aerial or underground cable which may have lightwave repeater (regenerator or optical amplifier) equipment interspliced to it at appropriate distances, but which has no line terminating elements terminated to such strands to operationalize its transmission capabilities.

13.2 Requirements

BellSouth shall make available Dark Fiber where it exists in BellSouth's network and where, as a result of future building or deployment, it becomes available. If BellSouth has plans to use the fiber within a two-year period, there is no requirement to provide said fiber to the CLEC.

- 13.3 If the requested dark fiber has any lightwave repeater equipment interspliced to it, BellSouth will remove such equipment at the CLEC's request subject to time and materials charges.
- 13.3.1 CLEC may test the quality of the Dark Fiber to confirm its usability and performance specifications. BellSouth shall use its best efforts to provide to the CLEC information regarding the location, availability and performance of Dark Fiber within ten (10) business days for a records based answer and twenty (20) business days for a field based answer, after receiving a request from the CLEC ("Request"). Within such time period, BellSouth shall send written confirmation of availability of the Dark Fiber ("Confirmation"). From the time of the Request to 45 days after Confirmation, BellSouth shall hold such requested Dark Fiber for the CLEC's use and may not allow any other party to use such media, including BellSouth.
- 13.3.2 BellSouth shall use its best efforts to make Dark Fiber available to the CLEC within thirty (30) business days after it receives written confirmation from the CLEC that the Dark Fiber previously deemed available by BellSouth is wanted for use by the CLEC. This includes identification of appropriate connection points (e.g., Light Guide Interconnection (LGX) or splice points) to enable the CLEC to connect or splice the CLEC provided transmission media (e.g., optical fiber) or equipment to the Dark Fiber.
- 13.4 Dark Fiber shall meet the manufacture's design specifications.
- 13.5 Additional Requirements for Dark Fiber
- 13.5.1 The CLEC may splice and test Dark Fiber obtained from BellSouth using the CLEC or CLEC's designated personnel. BellSouth shall provide appropriate interfaces to allow splicing and testing of Dark Fiber. BellSouth shall provide an excess cable length of 25 feet minimum (for fiber in underground conduit) to allow the uncoiled fiber to reach from the manhole to a splicing van.

14. Additional Requirements

This Section 14 sets forth the additional requirements for unbundled Network Elements which BellSouth agrees to offer to the CLEC.

14.1.1 Requirements

BellSouth shall provide performance equal to or better than all of the requirements set forth in this Section 14.2.

14.2 Performance

14.2.1 Scope:

This section addresses performance requirements for Network Elements and Ancillary Functions to provide local service. It includes requirements for the reliability and availability of Network Elements and Ancillary Functions, and quality parameters such as transmission quality (analog and digital), and speed (or delay). In addition, an overview of service performance requirements is given.

14.2.1.1 The General Performance Requirements in this section apply to all aspects of Network Elements and Ancillary Functions. Additional requirements are given in this performance section and in the individual Network Elements sections.

14.2.2 BellSouth shall work cooperatively with the CLEC to determine appropriate performance allocations across Network Elements.

14.2.2.1 BellSouth shall comply with the BellCore, ANSI, TIA/EIA, and IEEE technical standards regarding the performance of network elements and ancillary functions.

14.3 SS7 Network Interconnection

14.3.1 Definition

The figure below depicts Signaling System 7 (SS7) Network Interconnection. SS7 Network Interconnection is the interconnection of the CLEC local Signaling Transfer Point Switches (STPS) and the CLEC local or tandem switching systems with BellSouth STPSs. This interconnection provides connectivity that enables the exchange of SS7 messages among BellSouth switching systems and databases (DBs), the CLEC local or tandem switching systems, and other third-party switching systems directly connected to the BellSouth SS7 network.

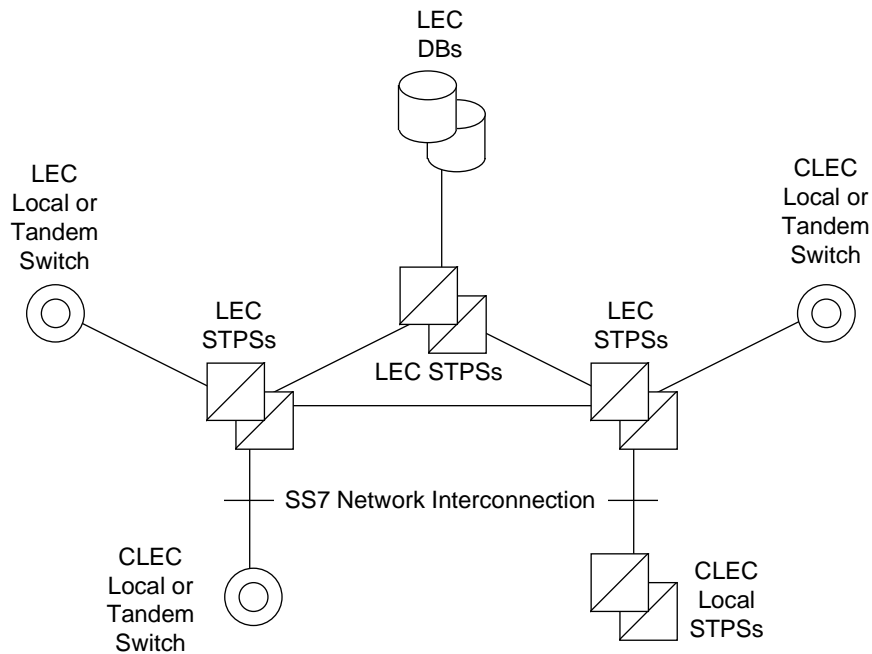

SS7 Network Interconnection

14.3.2 Technical Requirements

- 14.3.2.1 SS7 Network Interconnection shall provide connectivity to all components of the BellSouth SS7 network. These include:
 - 14.3.2.1.1 BellSouth local or tandem switching systems;
 - 14.3.2.1.2 BellSouth DBs; and
 - 14.3.2.1.3 Other third-party local or tandem switching systems.
- 14.3.2.2 The connectivity provided by SS7 Network Interconnection shall fully support the functions of BellSouth switching systems and DBs and the CLEC or other third-party switching systems with A-link access to the BellSouth SS7 network.
- 14.3.2.3 In particular the figure below depicts a circumstance where SS7 Network Interconnection shall provide transport for certain types of Transaction Capabilities Application Part (TCAP) messages. If traffic is routed based on dialed or translated digits between a CLEC's local switching system and a BellSouth or other third-party local switching system, either directly or via a BellSouth tandem switching system, then it is a requirement that the BellSouth SS7 network convey via SS7 Network Interconnection the TCAP messages that are necessary to provide Call Management services (Automatic Callback, Automatic Recall, and Screening List Editing)

between the CLEC local STPSs and BellSouth or other third-party local switch.

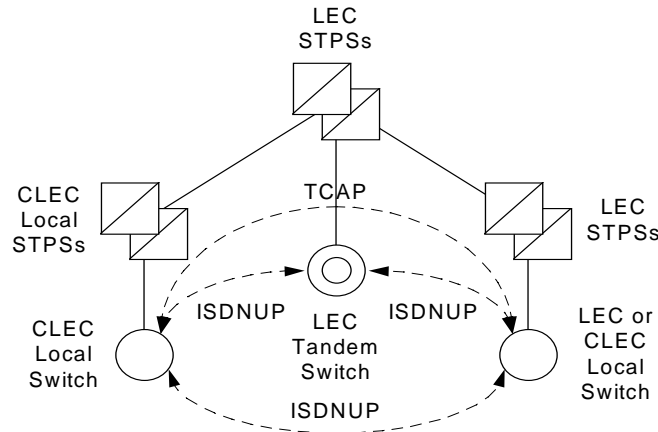

Interswitch TCAP Signaling for SS7 Network Interconnection

- 14.3.2.4 When the capability to route messages based on Intermediate Signaling Network Identifier (ISNI) is generally available on BellSouth STPSs, the BellSouth SS7 Network shall also convey TCAP messages using SS7 Network Interconnection in similar circumstances where the BellSouth switch routes traffic based on a Carrier Identification Code (CIC).
- 14.3.2.5 SS7 Network Interconnection shall provide all functions of the MTP as specified in ANSI T1.111 (Reference 0.0.0). This includes:
 - 14.3.2.5.1 Signaling Data Link functions, as specified in ANSI T1.111.2;
 - 14.3.2.5.2 Signaling Link functions, as specified in ANSI T1.111.3; and
 - 14.3.2.5.3 Signaling Network Management functions, as specified in ANSI T1.111.4.
- 14.3.2.6 SS7 Network Interconnection shall provide all functions of the SCCP necessary for Class 0 (basic connectionless) service, as specified in ANSI T1.112 (Reference 0.0.0). In particular, this includes Global Title Translation (GTT) and SCCP Management procedures, as specified in T1.112.4. Where the destination signaling point is a BellSouth switching system or DB, or is another third-party local or tandem switching system directly connected to the BellSouth SS7 network, SS7 Network Interconnection shall include final GTT of messages to the destination and SCCP Subsystem Management of the destination. Where the destination signaling point is a CLEC local or tandem switching system, SS7 Network Interconnection shall include intermediate GTT of messages to a gateway

pair of the CLEC's local STPSs, and shall not include SCCP Subsystem Management of the destination.

- 14.3.2.7 SS7 Network Interconnection shall provide all functions of the Integrated Services Digital Network User Part (ISDNUP), as specified in ANSI T1.113 (Reference 0.0.0).
- 14.3.2.8 SS7 Network Interconnection shall provide all functions of the TCAP, as specified in ANSI T1.114 (Reference 0.0.0).
- 14.3.2.9 If and when Internetwork MTP Routing Verification Test (MRVT) and SCCP Routing Verification Test (SRVT) become approved ANSI standards and available capabilities of BellSouth STPSs, SS7 Network Interconnection shall provide these functions of the OMAP.
- 14.3.2.10 SS7 Network Interconnection shall be equal to or better than the following performance requirements:
 - 14.3.2.10.1 MTP Performance, as specified in ANSI T1.111.6;
 - 14.3.2.10.2 SCCP Performance, as specified in ANSI T1.112.5; and
 - 14.3.2.10.3 ISDNUP Performance, as specified in ANSI T1.113.5.

14.3.3 Interface Requirements

- 14.3.3.1 BellSouth shall offer the following SS7 Network Interconnection options to connect the CLEC or CLEC-designated local or tandem switching systems or STPSs to the BellSouth SS7 network:
 - 14.3.3.1.1 A-link interface from the CLEC local or tandem switching systems; and
 - 14.3.3.1.2 B-link interface from the CLEC STPSs.
- 14.3.3.2 Each interface shall be provided by one or more sets (layers) of signaling links, as follows:

14.3.3.2.1 An A-link layer shall consist of two links, as depicted in the figure below.

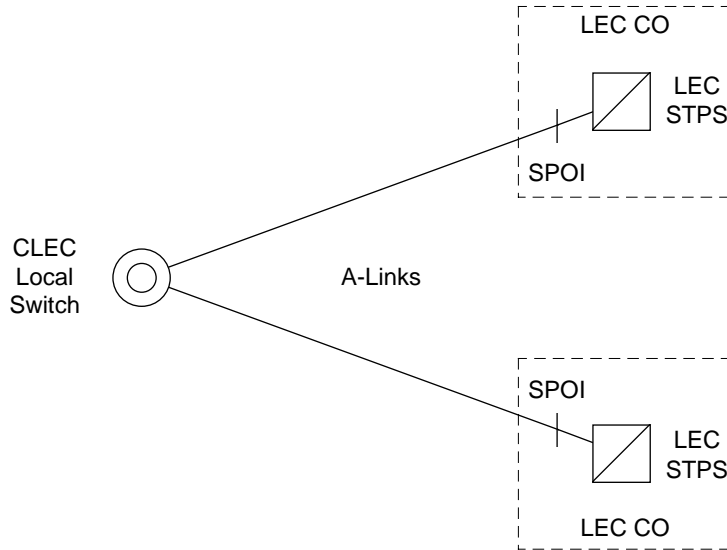

A-Link Interface

14.3.3.2.2 A B-link layer shall consist of four links, as depicted in the figure below.

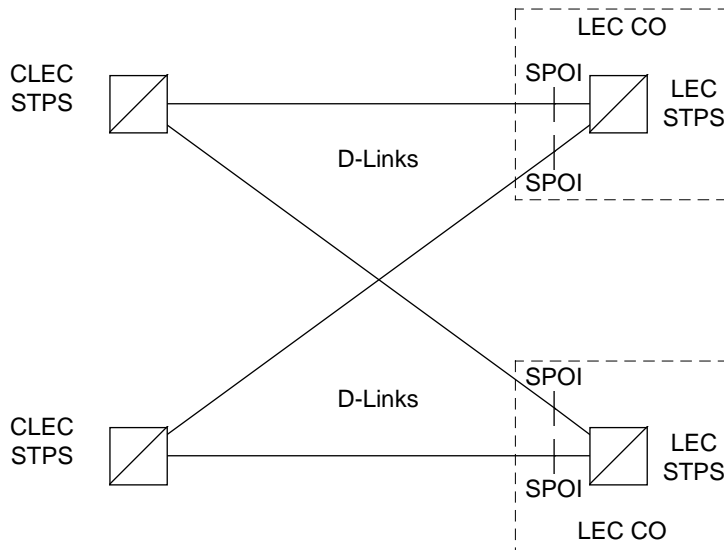

B-link Interface

- 14.3.3.3 The Signaling Point of Interconnection (SPOI) for each link shall be located at a cross-connect element, such as a DSX-1, in the Central Office (CO) where the BellSouth STPS is located. There shall be a DS1 or higher rate transport interface at each of the SPOIs. Each signaling link shall appear as a DS0 channel within the DS1 or higher rate interface. BellSouth shall offer higher rate DS1 signaling links for interconnecting the CLEC's local switching systems or STPSs with BellSouth STPSs as soon as these become approved ANSI standards and available capabilities of BellSouth STPSs. BellSouth and the CLEC will work jointly to establish mutually acceptable SPOI.
- 14.3.3.4 BellSouth CO shall provide intraoffice diversity between the SPOIs and the BellSouth STPS, so that no single failure of intraoffice facilities or equipment shall cause the failure of both B-links in a layer connecting to a BellSouth STPS. BellSouth and the CLEC will work jointly to establish mutually acceptable SPOI.
- 14.3.3.5 The protocol interface requirements for SS7 Network Interconnection include the MTP, ISDNUP, SCCP, and TCAP. These protocol interfaces shall conform to the following specifications:
- 14.3.3.5.1 Bellcore GR-905-CORE, Common Channel Signaling Network Interface Specification (CCSNIS) Supporting Network Interconnection, Message Transfer Part (MTP), and Integrated Services Digital Network User Part (ISDNUP);
- 14.3.3.5.2 Bellcore GR-1428-CORE, CCS Network Interface Specification (CCSNIS) Supporting Toll Free Service;
- 14.3.3.5.3 Bellcore GR-1429-CORE, CCS Network Interface Specification (CCSNIS) Supporting Call Management Services; and
- 14.3.3.5.4 Bellcore GR-1432-CORE, CCS Network Interface Specification (CCSNIS) Supporting Signaling Connection Control Part (SCCP) and Transaction Capabilities Application Part (TCAP).
- 14.3.3.6 BellSouth shall set message screening parameters to block accept messages from the CLEC's local or tandem switching systems destined to any signaling point in the BellSouth SS7 network with which the CLEC switching system has a legitimate signaling relation.
- 14.3.4 SS7 Network Interconnection shall be equal to or better than all of the requirements for SS7 Network Interconnection set forth in the following technical references:
- 14.3.4.1 ANSI T1.110-1992 American National Standard Telecommunications - Signaling System Number 7 (SS7) - General Information;

- 14.3.4.2 ANSI T1.111-1992 American National Standard for Telecommunications - Signaling System Number 7 (SS7) - Message Transfer Part (MTP);
- 14.3.4.3 ANSI T1.111A-1994 American National Standard for Telecommunications - Signaling System Number 7 (SS7) - Message Transfer Part (MTP) Supplement;
- 14.3.4.4 ANSI T1.112-1992 American National Standard for Telecommunications - Signaling System Number 7 (SS7) - Signaling Connection Control Part (SCCP);
- 14.3.4.5 ANSI T1.113-1995 American National Standard for Telecommunications - Signaling System Number 7 (SS7) - Integrated Services Digital Network (ISDN) User Part;
- 14.3.4.6 ANSI T1.114-1992 American National Standard for Telecommunications - Signaling System Number 7 (SS7) - Transaction Capabilities Application Part (TCAP);
- 14.3.4.7 ANSI T1.115-1990 American National Standard for Telecommunications - Signaling System Number 7 (SS7) - Monitoring and Measurements for Networks;
- 14.3.4.8 ANSI T1.116-1990 American National Standard for Telecommunications - Signaling System Number 7 (SS7) - Operations, Maintenance and Administration Part (OMAP);
- 14.3.4.9 ANSI T1.118-1992 American National Standard for Telecommunications - Signaling System Number 7 (SS7) - Intermediate Signaling Network Identification (ISNI);
- 14.3.4.10 Bellcore GR-905-CORE, Common Channel Signaling Network Interface Specification (CCSNIS) Supporting Network Interconnection, Message Transfer Part (MTP), and Integrated Services Digital Network User Part (ISDNUP);
- 14.3.4.11 Bellcore GR-954-CORE, CCS Network Interface Specification (CCSNIS) Supporting Line Information Database (LIDB) Service;
- 14.3.4.12 Bellcore GR-1428-CORE, CCS Network Interface Specification (CCSNIS) Supporting Toll Free Service;
- 14.3.4.13 Bellcore GR-1429-CORE, CCS Network Interface Specification (CCSNIS) Supporting Call Management Services; and,
- 14.3.4.14 Bellcore GR-1432-CORE, CCS Network Interface Specification (CCSNIS) Supporting Signaling Connection Control Part (SCCP) and Transaction Capabilities Application Part (TCAP).

14.4 Network Interconnection

14.4.1 Technical Requirements

- 14.4.1.1 When requested by the CLEC, BellSouth shall provide interconnections between BellSouth Network Elements provided to the CLEC and the CLEC's network at transmission rates designated by the CLEC, including, but not limited to DS1, DS3, and STS-1.
- 14.4.1.2 Traffic shall be combined and routed as follows:
- 14.4.1.2.1 BellSouth shall provide direct trunks for local and intraLATA traffic (except 911, directory assistance, operator services, and other services that may require special routing) and, at the CLEC's request, BellSouth shall allow the CLEC to route such traffic either directly to a BellSouth's tandem or directly to a BellSouth's end-office.
- 14.4.1.2.2 At the CLEC's request, BellSouth shall receive the CLEC traffic destined to BellSouth Operator Systems Network Element, on trunks from a CLEC end-office or a CLEC tandem.
- 14.4.1.2.3 At the CLEC's request, BellSouth shall receive the CLEC's CAMA-ANI (Centralized Automatic Message Accounting - Automatic Number identification) traffic destined to BellSouth B911 PSAPs, or E911 tandems, on trunks from a CLEC end-office.
- 14.4.1.3 When requested by the CLEC and authorized by a third party carrier, BellSouth shall provide interconnections between the CLEC's network, and the other carrier's network through BellSouth network at transmission rates designated by the CLEC, including, but not limited to DS1, DS3, and STS-1. BellSouth shall combine and route traffic to and from other local carriers and interLATA carriers through BellSouth network, and at the CLEC's request, BellSouth shall record and keep records of such traffic for the CLEC's billing purposes.
- 14.4.1.4 The parties agree to implement the most efficient trunking arrangement to exchange all traffic unless otherwise agreed. For purposes of this Section, "most efficient" means the fewest number of trunks required to carry a forecasted load at P.01 grade of service. Initially, BellSouth and the CLEC will provide one-way trunk groups for completion of BellSouth and the CLEC's originated local and intraLATA traffic.