

Local Number Portability Ordering Guide for CLECs

Network & Carrier Services

Copyright

October 1999

© BellSouth Telecommunications

Contents

Subject	Page
Introduction	v
Purpose	v
Version Information	v
1. Introduction to Local Number Portability	1
1.1 Description of LNP	1
1.2 Network Provisioning for Local Number Portability	1
1.3 LNP Order Status	3
2. LNP Order Process Flows	5
2.1 High Level LNP Order Process Flow and Narrative	5
2.2 Detailed LNP Order Process Flow and Narrative	7
2.2.1 LNP Order Process - Port Out and Port Out with Loop	8
3. LNP Clarification and Supplement (SUP) LSR Process Flows	17
3.1 Detailed LNP Clarification Process Flow and Narrative	17
3.1.1 Clarification Process	17
3.2 Detailed Supplement (SUP) LSR Process Flow and Narrative	18
3.2.1 Supplement (SUP) LSR Change Process	19
4. Requirements for LNP Ordering	23
4.1 Requirements for LNP Ordering	23
4.2 Local Number Portability Rules	24
4.3 Required Forms	26
4.4 Minimum Required Fields for Faxed LNP Orders	28
4.4.1 LSR Minimal Required Fields for Faxed Orders (LNP Port-out With or Without Loop)	28
4.4.2 Faxed End User Information Form Fields	32
4.4.3 Faxed Number Portability Form Fields	33
4.4.4 Faxed Loop Service with Number Portability Form Fields	34
4.5 Complex LNP Orders	36
4.6 Faxed Loop Service with Number Portability Fields	36
4.7 Project Managed LNP Orders and Standard Intervals	37
5. Critical Success Factors for LNP Ordering	39
5.1 Pre-Order Information	39
5.2 LSR Order Forms for LNP	39
5.3 Supplemental LSRs	40
5.4 Clarifications	40
5.5 Standard Intervals	40
5.6 NPAC Communication	41

5.7	E911 Lock Down	41
6.	System Interfaces	43
6.1	Interface Options for Order Submission	43
6.2	System Interface Descriptions	43
7.	Frequently Asked Questions	47
7.1	General	47
7.2	Ordering Options	48
7.3	LSR Error Notices	48
7.4	Due Dates	49
7.5	NPAC Communication	49
8.	LNP Ordering Checklist	51
8.1	LNP Ordering Checklist	51
9.	Glossary of LNP Terms	53
9.1	Glossary of LNP Terms	53

Introduction

Purpose

This document contains information on Local Number Portability for CLECs interested in ordering this service from BellSouth. The Guide is intended to increase the CLEC's understanding of LNP Order Process at BellSouth; to provide guidelines for LSR completion; and to offer information on critical success factors for LSR submission.

This guide is intended to be used as a supplement to, not a replacement for, the **BellSouth Ordering Guide for CLECs** and the **LEO Implementation Guide**, which are available on-line through the BellSouth Interconnection website at: <http://www.interconnection.bellsouth.com/guides/guides.html>

Information resources reviewed for this guide include, but are not limited to:

- BellSouth CLEC Interconnections Web Site
- BellSouth Interconnection Services Ordering Guide for CLECs
- BellSouth LNP Documentation
- North American Numbering Council (NANC) Architecture and Administrative Plan for Local Number Portability
- North American Numbering Council (NANC) Inter-Service Provider LNP Operations Flows
- www.fcc.gov
- www.npac.com/home.htm
- www.ported.com

Version Information

Table A Revision History

Chapter	Action Request #	Date/Issue	Description
Various	N/A	October 1999/ 1b	General Revision
Various	N / A	April 2, 1999 / 1a	General Revisions
All	N / A	March, 1999 / 1	First Issue

1. Introduction to Local Number Portability

1.1 Description of LNP

Local Service Provider Portability

Local Number Portability (LNP) is a part of local competition that provides end users with the ability to retain their phone numbers when they change their Local Service Provider.

Phase	Description
Local Service Provider (SPP)	Allows customers to keep their current telephone number(s) if they chose to switch from their current Local Service Provider to another.

The Telecommunications Act of 1996 requires BellSouth to provide a mechanism for customers to retain their current telephone numbers when they change their Local Service Provider.

Orders of the FCC pursuant to the Telecommunications Act of 1996 provide deadlines for implementing Local Service Provider Portability (SPP) in the top 100 metropolitan areas in the United States. The BellSouth territory includes 21 of the top 100 metropolitan areas. To learn more about BellSouth's implementation schedule plan , please visit us at:

Note: http://g8058183.ga.bst.bls.com/ibu/files/infra_lnp/LNP/LNPtrack.xls

1.2 Network Provisioning for Local Number Portability

Interim Number Portability (INP) is a temporary solution for porting numbers which involves two telephone numbers to route calls to the serving wire center using one of the following methods:

- Remote Call Forwarding
- Direct Inward Dialing
- Route Index Hubbing

Local Number Portability (LNP) is the long range solution for Service Provider Portability (SPP) and includes the following characteristics:

- uses only one telephone number.
- requires significant network architecture hardware and software upgrades.
- uses the Advanced Intelligent Network (AIN).
- requires new routing methodology to send calls to the wire center of the company currently providing the local service.

Note: All calls to a port eligible NPA NXX will route using the AIN to look up the correct routing information (LRN) for the telephone number.

The **LNP Gateway (LNP GW)** is a major link in the LNP process for BellSouth since it provides both internal and external communications with various interfaces and processes, including:

- linking BellSouth to the Number Portability Administration Center (NPAC).
- allowing for inter-company communications between BellSouth and the CLECs for electronic ordering.
- providing interface between NPAC and AIN SMS for LNP routing processes.

The **Number Portability Administration Center (NPAC)** is a neutral third party organization that oversees the porting of telephone numbers for Local Number Portability. The NPAC maintains and communicates LNP-related data including

- Old Service Provider ID (OCN)
- New Service Provider ID (OCN)
- Local Routing Number (LRN)
- Due Dates
- CLASS-DPC
- CLASS-SSN
- LIDB-DPC
- LIDB-SSN
- CNAM-DPC
- CNAM-SSN
- ISVM-DPC
- ISVM-SSN

The BellSouth LNP Gateway must communicate with the NPAC as to whether numbers are porting out or porting in. The messages sent to and from the NPAC are called Subscription Versions (SVs). Subscription Versions are the messages that flow through the NPAC to provide information for routing calls to ported numbers. The SV can only contain one telephone number (TN), which means that one LSR may have many TNs and SVs associated with it.

LSRs for INP

LSRs requesting Interim Number Portability (INP) will not be accepted with due dates by BellSouth after the completion for each phase. If the due date is between ready to port and completion date, the CLEC may request INP or LNP.

1.3 LNP Order Status

Online Order Status Information For Faxed LSR's

CLEC PON Status Reports for faxed LNP LSRs are now available via BellSouth's website at <https://clec.bellsouth.com>. This report is located in the same location as your company's measurement reports. The information can be found as report number 00 (PON Report) on the CLEC reports page.

The report will provide status for all orders tracked into BellSouth's Local Order Number (LON) systems for the most recent 31 days. The report is CLEC specific. This will answer the majority of questions CLECs have about orders that have been submitted.

Each CLEC will be required to have a specific login and password to access these reports. The application for this report is also found on the web. Once the form is completed, it should be sent to the account team for processing.

EDI/TAG POS and CN

Users submitting LSR's through EDI or TAG receive Pending Order Statuses (POS) and Jeopardy Notifications back through the return path for these systems. Completion notification (CN) is sent when all service orders associated with the LSR are complete.

2. LNP Order Process Flows

2.1 High Level LNP Order Process Flow and Narrative

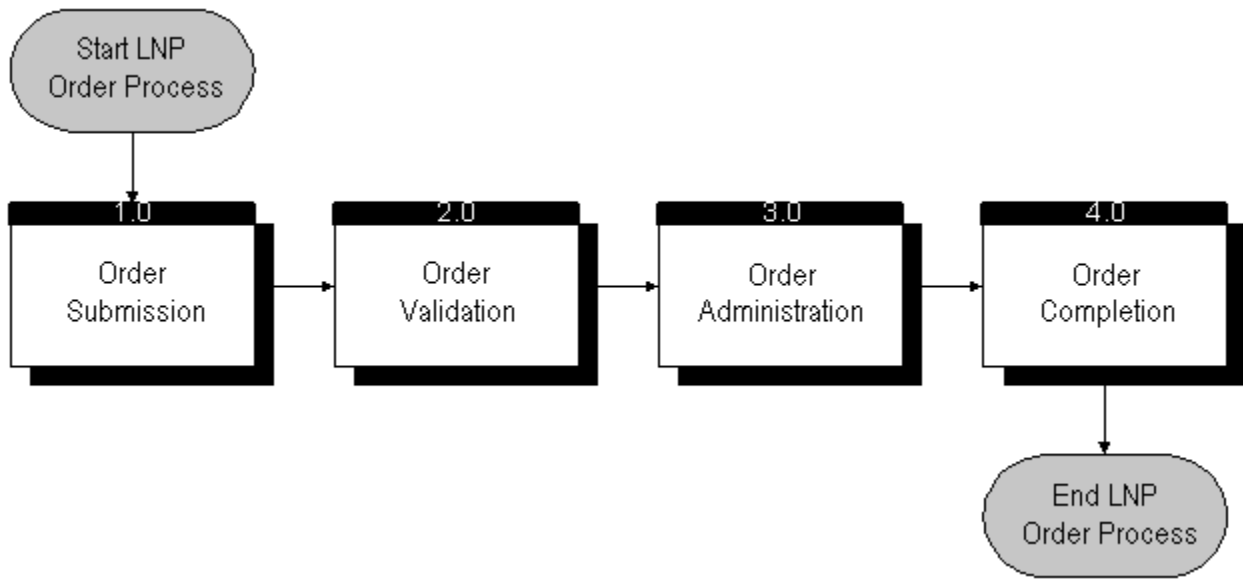

Figure 1 High Level LNP Order Process Flow

Step	Action
1.0 Order Submission:	CLEC sends LNP LSR to BellSouth LCSC via fax, EDI, or TAG.
2.0 Order Validation:	BellSouth validates CLEC LSR for errors, and requests clarification when necessary.

Step	Action
3.0 Order Administration:	BellSouth sends FOC to CLEC if clarification is not needed. CLEC receives FOC and immediately sends Create SV to NPAC. BellSouth then sends Concur SV to NPAC. The CLEC sends the Activate SV to NPAC on the Due Date, porting the number.
4.0 Order Completion:	BellSouth completes the Disconnect order and sends E911 Unlock message to SCC. CLEC sends E911 Migrate message to SCC.

2.2 Detailed LNP Order Process Flow and Narrative

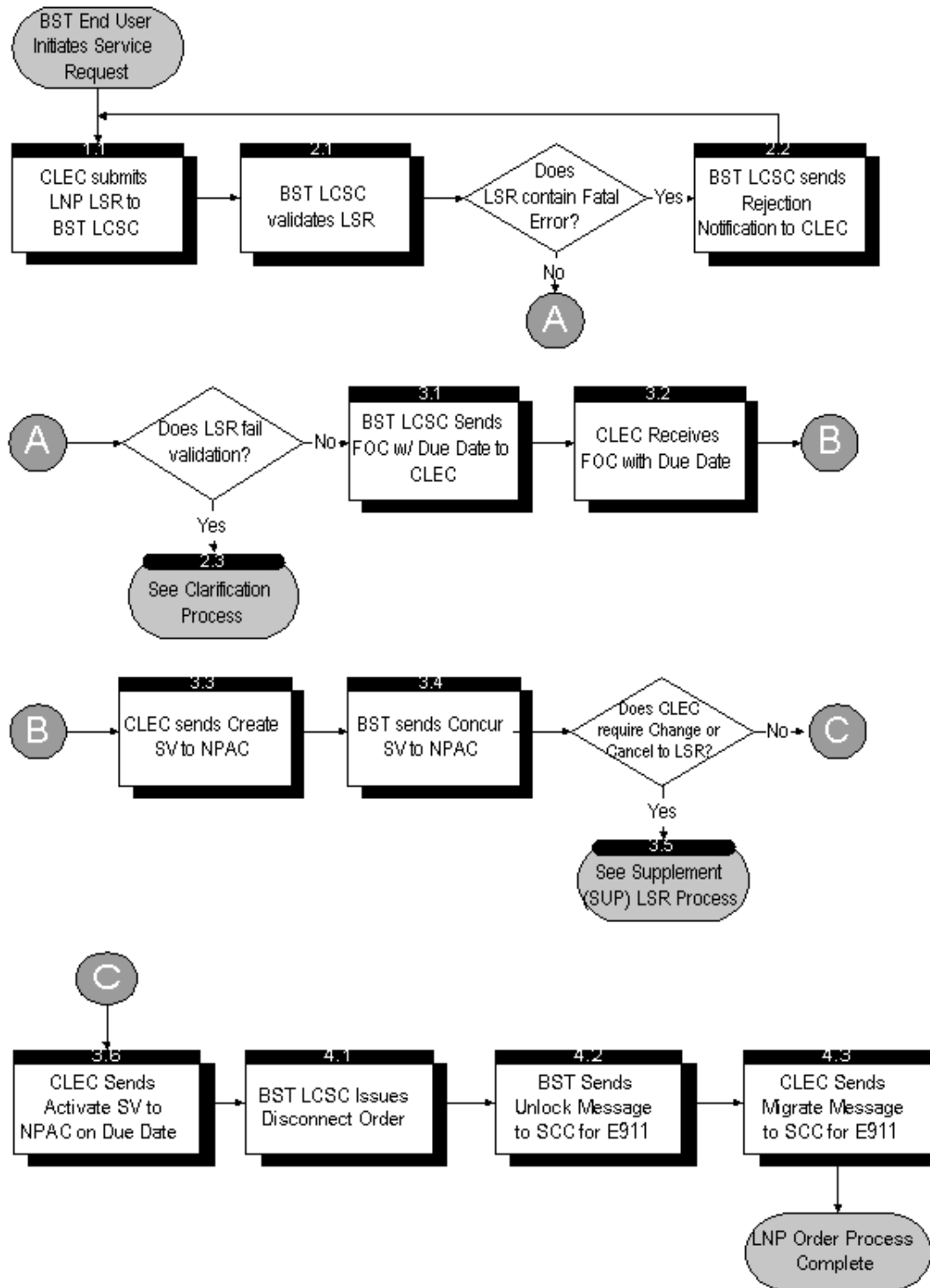

Figure 2 Detailed LNP Order Process Flow

2.2.1 LNP Order Process - Port Out and Port Out with Loop

1.0 Order Submission

1.1

Step	Action
Process Step	CLEC sends LNP LSR to BST LCSC via fax, EDI or TAG
Predecessor	Bell South End User initiates LNP Request with CLEC
Input	End-user CSR; BellSouth Ordering Guide for CLECs; order forms; BellSouth Standard Interval information; BellSouth LNP Ordering Checklist (Section 8.0 of BellSouth LNP Ordering Guide for CLECs)
Output	BellSouth LCSC receives paper copy LSR via fax server OR digital LSR for EDI or TAG orders
Key Interface	Fax; EDI; TAG
Notes	LSR format defined by OBF

2.0 Order Validation

2.1

Step	Action
Process Step	BST LCSC validates LSR
Predecessor	CLEC submission of LSR
Input	CLEC LSR
Output	Validated LSR

Step	Action
Key Interface	BellSouth LNP-Gateway
Notes	CLECs may access pre-order support using a web browser and the LENS interface. Use the Inquiry function to confirm the accuracy of customer record information, address, etc.
Decision Point	

Step	Action
Process Step	Does LSR contain Fatal Error*?
If YES:	Proceed to 2.2 "BST LCSC sends Rejection Notification to CLEC"
If NO:	Proceed to Decision Point "Does LSR fail validation?"
Notes	*Fatal Reject errors include missing required fields, duplicate PON, and invalid entries.

2.2

Step	Action
Process Step	BST LCSC sends Rejection Notification to CLEC
Predecessor	CLEC LNP LSR contains fatal errors (e.g., missing fields, duplicate PON, invalid entries)
Input	Rejected LSR
Output	Notification of fatal errors sent to CLEC
Key Interface	Fax, EDI, TAG, BellSouth LNP-Gateway
Notes	Fatal reject notices for EDI or TAG orders will be transmitted electronically via EDI or TAG. Fatal reject notices for faxed orders will be transmitted via fax.

Decision Point

Step	Action
Process Step	Does LSR fail validation?
If YES:	Proceed to 2.3 "Clarification Process"
If NO:	Proceed to 3.1 "BellSouth LCSC Sends FOC with Due Date to CLEC"
2.3 See Clarification Process	
3.0 Order Administration	
3.1	

Step	Action
Process Step	BST LCSC Sends FOC with Due Date to CLEC
Predecessor	CLEC LSR passes BellSouth LNP Gateway validation.
Input	Valid LSR
Output	FOC is sent to CLEC via EDI, TAG, or fax; BellSouth LCSC issues 10 digit trigger order if applicable
Key Interface	EDI; TAG; fax; BellSouth LNP Gateway
Notes	"Trigger" may not be applicable for all types of service. See Local Number Portability Rules in section 4.0 for more details.

3.2

Step	Action
Process Step	CLEC receives FOC with Due Date
Predecessor	BellSouth LCSC sends CLEC FOC via fax, EDI, or TAG
Input	Valid LSR with FOC
Output	CLEC receives FOC with Due Date
Key Interface	Fax; EDI; TAG

3.3

Step	Action
Process Step	CLEC sends Create SV to NPAC with Due Date on FOC and Time set to 00:00
Predecessor	FOC received by CLEC
Input	FOC with Due Date sent by BellSouth LCSC
Output	NPAC notifies BellSouth LCSC that CLEC has sent Create SV
Key Interface	NPAC - Service Order Administration (SOA); BellSouth LNP Gateway
Notes	SV - Subscription Version BellSouth will place SVs in Conflict if CLEC sends the Create SV to NPAC prior to CLEC receiving FOC from BellSouth.

3.4

Step	Action
Process Step	BST LCSC sends Concur SV to NPAC with Due Date on FOC and Time set to 00:00
Predecessor	BellSouth receives notification of Create SV from NPAC
Input	Create SV sent by CLEC to NPAC
Output	NPAC notifies CLEC that Concur SV has been sent by BellSouth
Key Interface	NPAC - Service Order Administration (SOA); BellSouth LNP Gateway
Notes	BellSouth LCSC has <u>18 hours</u> after Create SV to send Concur SV to NPAC.
Decision Point	

Step	Action
Process Step	Does CLEC require Change* or Cancel to Original LSR?
If YES:	Proceed to 3.5 "Supplement (SUP) LSR Process"
If NO:	Proceed to 3.6 "CLEC sends Activate SV to NPAC with Due Date on FOC"
Notes	*Change to original LSR includes: Due Date change; Add/Remove TNs

3.5

See Supplement (SUP) LSR Process

3.6

Step	Action
Process Step	CLEC Sends Activate SV to NPAC on Due Date on FOC
Predecessor	BellSouth LCSC sends Concur SV to NPAC
Input	CLEC receives Concur SV from NPAC
Output	NPAC receives Activate SV from CLEC on Due Date on FOC
Key Interface	NPAC - Service Management System (SMS); BellSouth LNP Gateway
Notes	BellSouth is no longer responsible for customer after CLEC sends Activate SV to port the number. Activate SV should be sent for <u>all</u> telephone numbers on the LSR.

4.0 Order Completion

4.1

Step	Action
Process Step	BST LCSC Issues Disconnect Order
Predecessor	CLEC sends Activate SV to port number.
Input	NPAC notification of CLEC Activate SV sent to BellSouth
Output	Disconnect service orders issued by BellSouth LCSC

Step	Action
Key Interface	NPAC - Service Management System (SMS); BellSouth LNP Gateway
Notes	Following this point, questions regarding maintenance & repair should go to the UNE Center. LCSC will not issue disconnect until the Activate SV is received for <u>all</u> telephone numbers on LSR.
4.2	

Step	Action
Process Step	BST sends Unlock Message to SCC for E911
Predecessor	BellSouth completes Disconnect service order
Input	Disconnect service order
Output	SCC receives BellSouth's Unlock message
Key Interface	SCC
Notes	BellSouth will not send the Unlock message to SCC before the Disconnect service order is complete. BellSouth will not send the Unlock message for E911 until Activate SV is received for <u>all</u> telephone numbers on LSR.
4.3	

Step	Action
Process Step	CLEC Sends Migrate Message to SCC for E911
Predecessor	BellSouth Unlock message has been received by E911 SCC
Input	BellSouth Unlock message

Step	Action
Output	E911 record locked
Key Interface	SCC
Notes	If CLEC Migrate (Lock) message makes it to SCC before BellSouth's Unlock Message, then the CLEC message goes on an error report. BellSouth will not send Unlock message to SCC until CLEC has sent Activate SVs to NPAC for <u>all</u> telephone numbers on LSR.

3. LNP Clarification and Supplement (SUP) LSR Process Flows

3.1 Detailed LNP Clarification Process Flow and Narrative

Clarifications

Any LSR will be returned to the CLEC for clarification when BellSouth is not able to issue the orders requested due to:

- incomplete information
- incorrect information
- conflicting information

For faxed requests, clarifications will be sent via fax. Clarifications for EDI or TAG orders are sent via EDI or TAG. The CLEC has 10 business days to respond to the request for clarification by submitting a supplemental LSR. (SUP)* If no response is received, the LSR will be canceled on the eleventh day. If canceled by BellSouth, a new LSR (PON) must be submitted.

Note: * SUP LSRs must be sent using the same ordering method as the original LSR (i.e., Fax, EDI, TAG)

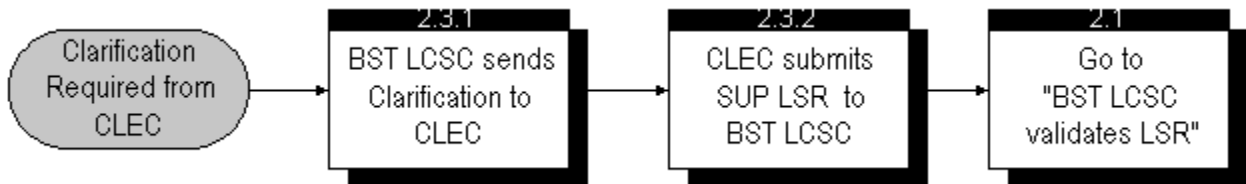

Figure 3 Detailed LNP Clarification Process Flow

3.1.1 Clarification Process

2.3.1

Step	Action
Process Step	BST LCSC sends Clarification to CLEC via Fax, EDI, or TAG
Predecessor	LSR falls out of BellSouth LNP-Gateway and requires clarification

Step	Action
Input	LSR rejected by BellSouth LNP-Gateway for clarification
Output	Clarification sent to CLEC via fax, EDI, or TAG
Key Interface	Fax; EDI; TAG

2.3.2

Step	Action
Process Step	CLEC submits SUP LSR via fax, EDI, or TAG to BST LCSC
Predecessor	LSR falls out of LNP-Gateway and requires clarification
Input	Clarification sent by LCSC via fax, EDI, or TAG to CLEC
Output	SUP LSR sent to LCSC
Key Interface	Fax; EDI; TAG
Notes	SUP must be sent via the same channel (EDI, TAG or fax) as the original LSR.

2.1
Go to "BST LCSC validates LSR"

3.2 Detailed Supplement (SUP) LSR Process Flow and Narrative

Supplement (SUP) LSR

A supplemental change (SUP) LSR will be required if a CLEC:

- has been asked for clarification on an LNP LSR,
- is requesting a Due Date Change,

- would like to cancel an LSR,
- would like to add/remove telephone numbers for porting on LSR.

If a CLEC is changing the original LSR, a SUP LSR must be filed with BellSouth prior to any contact with NPAC.

Note: SUP LSRs must be sent using the same ordering method as the original LSR (i.e., Fax, EDI, TAG)

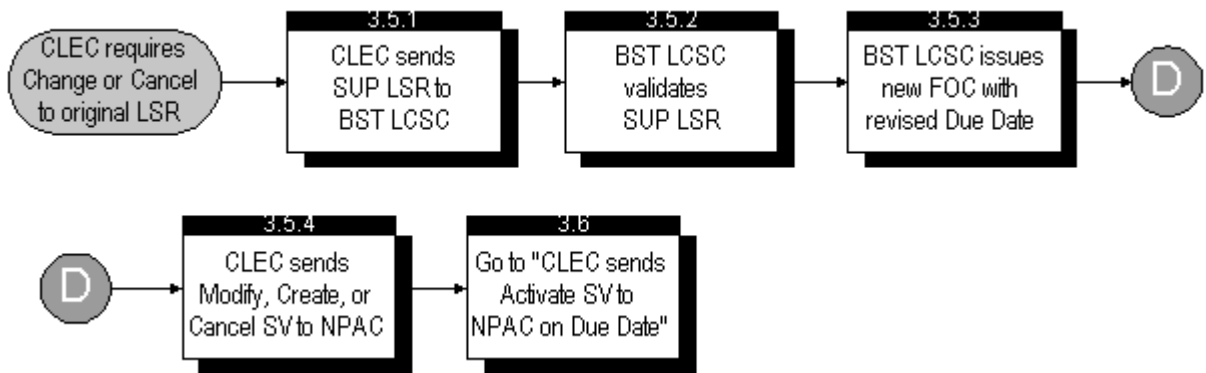

Figure 4 Detailed Supplement (SUP) LSR Process Flow

3.2.1 Supplement (SUP) LSR Change Process

3.5.1

Step	Action
Process Step	CLEC sends SUP LSR to BST LCSC
Predecessor	Create and Concur SV received by NPAC for original LSR
Input	Original FOC and LSR; SUP LSR
Output	BST LCSC receives SUP LSR via fax, EDI, or TAG

Step	Action
Key Interface	EDI; TAG; Fax
Notes	SUP LSR must be sent to BellSouth LCSC and revised FOC received by CLEC prior to CLEC sending Modify SV to NPAC. CLEC must complete SUP field and VER field on LSR form.

3.5.2

Step	Action
Process Step	BST LCSC validates SUP LSR
Predecessor	CLEC submission of SUP LSR
Input	CLEC SUP LSR
Output	Validated SUP LSR; BellSouth updates internal records with supplemental information on LSR
Key Interface	BellSouth LNP-Gateway

3.5.3

Step	Action
Process Step	
Predecessor	BellSouth receives and validates SUP LSR from CLEC
Input	SUP LSR; original LSR and FOC
Output	BellSouth LCSC updates internal records with new Due Date; new FOC sent to CLEC via fax, EDI, or TAG

Step	Action
Key Interface	BST LNP-Gateway; EDI; TAG; fax
Notes	CLEC must receive FOC prior to sending Modify SV to NPAC Revised Due Date on FOC will be based on the receipt of SUP LSR and the BST Standard Intervals.
3.4	

Step	Action
Process Step	CLEC sends Modify, Create or Cancel SV to NPAC
Predecessor	CLEC receives revised FOC with new Due Date
Input	SUP LSR; Revised FOC with new Due Date
Output	NPAC receives Modify, Create, or Cancel SV
Key Interface	NPAC - Service Order Administration (SOA)
Notes	If changing the Due Date on LSR, CLEC sends a Modify SV If removing TNs to port from original LSR, CLEC sends a Cancel SV for each TN. If adding TNs for porting, CLEC sends Create SVs for each new TN on the SUP LSR. If canceling the original LSR, CLEC sends Cancel SV to NPAC.

3.6

Go to "CLEC Sends Activate SV to NPAC on Due Date"

4. Requirements for LNP Ordering

4.1 Requirements for LNP Ordering

A telephone number may port out when all of the following are true:

- NPA NXX is portable.
- telephone number is a working number or end user is paying to reserve the number.
- end user name on the LSR matches the BellSouth customer record.
- end user address on the LSR is in the same Toll Message Rate Center (TMRC) as the address on the BellSouth customer record.
- number is associated with a line type that is portable. (Refer to Local Number Portability Rules - Section 4.2 below to determine if service type is portable and if a trigger order is necessary)

The responsibilities for porting out telephone numbers are described in the following table.

Table B The responsibilities for porting out telephone numbers are described in the following table

Work Group	Responsibilities
CLEC	<ul style="list-style-type: none"> • Send LSR to BellSouth to request number(s) to be ported. • Receives FOC before sending SVs to NPAC. • Provide service to end user. • Notify the NPAC when ready to port the number. • Update E911 information. • Send SUP LSR to change Due Date, Cancel LSR, or modify TN on LSR.
LCSC	<ul style="list-style-type: none"> • Process LSR and FOC for port out requests. • Issue trigger/port out/listing/loop service orders. • Send and receive NPAC messages.
UNE Center	<ul style="list-style-type: none"> • Coordinate port out with loop orders with CLEC as needed. • Complete port out with loop orders as needed. <p>Note: UNE Center is involved in provisioning only if loop is requested.</p>

4.2 Local Number Portability Rules

The following table may be used to determine if the service type is portable and if a trigger order is required. The existing service or line type is for reference only because the service is not portable. Only the number is ported.

Table C Local Number Portability Rules

Service / Line Type	Portable - w/ LRN	Trigger	Notes
AdWatch	Y	N	The number will no longer work for AdWatch once it is Ported.
Choke Codes	N		Does not involve LRN

Table C Local Number Portability Rules (continued)

Service / Line Type	Portable - w/ LRN	Trigger	Notes
Denied for Non-Pay	Y	N	
DID (Block of 20)	Y	N	To Port a portion of a range will require special assembly.
ESSX / MultiServ	Y	Y	If lines are in a hunting arrangement, see hunting Lines below.
FX / FCO	Y	Y	The number can be ported within the same Toll Message Rate Center (TMRC). The BST designed circuit will be disconnected and the new service provider must establish the service.
Hunting Lines	Y	Y	If not all of the numbers in the hunt group are porting, the numbers porting must be removed from the hunt group the day before the port due date. CLEC can determine Frame Due Time or use BST default of 9:00 PM day before Port.
ISDN	Y	Y	
N11	N		
Out dial trunks	Y	N	
Party Line	Y	N	The number may be ported without loop. The BST service must be disconnected
Remote Call Forwarding / Interim Number Portability	Y	N	
Reserved numbers	Y	N	Only numbers reserved with chargeable USOCs may be ported
RingMaster	Y	N	
Sub-Let	Y	Y	
Surrogate Client Number	Y	N	
Suspend for season	Y	N	
Uniserve	N		

- continued -

Table C Local Number Portability Rules (continued)

Service / Line Type	Portable - w/ LRN	Trigger	Notes
Warm Line	N		
ZipCONNECT	N		

4.3 Required Forms

Required Forms for Port Out

The CLEC submits the following forms to the LCSC to request telephone numbers to Port Out:

- Local Service Request (LSR)
- End User (EU)
- Number Portability (NP) or Loop Service with Number Portability (LSNP)

Conditional Forms for Porting Out

- Directory Listing Request (DLR)

If listings are required, the Directory Listing Request (DLR) will be needed unless the ACT code is **W** . The **W** ACT code is a switch as is for listings and directory delivery requirements. This activity code is only valid when porting out all numbers on an account. Without a **W** ACT code on a full port, all listings are deleted unless the CLEC submits a DLR.

LNP Order Form Matrix

Table D LNP Order Form Matrix

When Ordering:	These Forms Are:				
	LSR	EU	NP	LSNP	DLR
Number Portability	R	R	R	P	C*
Loop Service with Number Portability	R	R	P	R	C*

Form Names:	Form Requirements:
LSR = Local Service Request Form	R=Required
EU = End User Form	P=Prohibited
NP = Number Portability Form	C=Conditional

- continued -

LSNP = Loop Service with Number Portability Form	O=Optional
DLR = Directory Listing Request Form	

* If all the telephone numbers for the Account are converting (Full Migration) and no change is being made to the listing, the DLR is not required. (This requires an ACT code of **W**.) However, if only a portion of the lines on the account are converting (Partial Migration), the DLR should be submitted to request listings. A DLR is **not required** when associated with LNP (Local Number Portability), even for partial migration. However, directory listings or directory delivery will not be established without a DLR.

Required Forms for SUPs

A supplemental change (SUP) LSR will be required if a CLEC:

- has been asked for clarification on an LNP LSR,
- is requesting a Due Date Change,
- would like to cancel an LSR,
- would like to add/remove telephone numbers for porting on LSR.

Use the **LNP Order Matrix Form** above to determine which order forms must be used.

A supplemental change LSR (SUP) should contain complete information and will supersede the original LSR. The SUP must reflect the same PON and CC from the original request. It must also have a higher version number in the VER field. The SUP field must be populated with:

- (1) to Cancel. (Prohibited if CLEC has sent Activate SV to NPAC for any numbers on the LSR)
- (2) for Desired Due Date changes. The new date is specified in the DDD field. If the request is to establish a due date less than the standard interval (from the date the SUP is sent), the EXP field must also be populated.
- (3) for other types of changes. This includes adding or removing porting numbers. Also includes requests for a change in desired due date in conjunction with other changes to a pending order. The standard interval should be used to establish a new due date when adding or removing ported numbers.

EDI, TAG and Fax requests may not be combined for the same PON. If an LSR is submitted via:

- EDI all SUPs for the PON must be sent through EDI.
- Fax all SUPs for the PON must be faxed.
- TAG all SUPs for the PON must be sent through TAG.

4.4 Minimum Required Fields for Faxed LNP Orders

Minimal Required Fields on the Faxed LSR for LNP

Please review the notes for each field, as they may highlight common errors on LNP LSRs. The fields below are those required for LNP orders. They may be required, conditional, or optional for other types of orders.

4.4.1 LSR Minimal Required Fields for Faxed Orders (LNP Port-out With or Without Loop)

Table E LSR Minimal Required Fields for Faxed Orders (LNP Port-out With or Without Loop)

Field Abbreviation	Field Name	Explanation
CCNA	Customer Carrier Name Abbreviation	Refer to CLEC Order Guide 9.1.2.1 Note: Required for orders with loop.
PON	Purchase Order Number	Refer to CLEC Ordering Guide 9.1.2.2 Note: Every new request requires a unique PON number. Note: When issuing a SUP, the same PON number on the original LSR should be used; however, the (VER) must be different.
VER	Version Identification	Refer to CLEC Ordering Guide 9.1.2.3 Note: This field is conditional. When submitting a supplement (SUP) LSR, the CLEC must populate this field to uniquely distinguish this LSR from any other version. Note: If VER is entered, CLEC must also complete SUP field.
SC	Service Center	Refer to CLEC Ordering Guide 9.1.2.7
PG__OF__	Page number / Total pages	Refer to CLEC Ordering Guide 9.1.2.8
D / TSENT	Date and Time Sent	Refer to CLEC Ordering Guide 9.1.2.9

- continued -

Table E LSR Minimal Required Fields for Faxed Orders (LNP Port-out With or Without Loop) (continued)

Field Abbreviation	Field Name	Explanation
DDD	Desired Due Date	Refer to CLEC ordering guide 9.1.2.10 Note: Reference BST Standard Intervals for LNP when completing this field.
DFDT	Desired Frame Due Time	Refer to CLEC Ordering guide 9.1.2.14
REQTYP	Requisition Type and Status	Refer to CLEC Ordering Guide 9.1.2.17 Note: LNP with loop, will always be BB . LNP without loop, will always be CB
ACT	Activity	Refer to CLEC Ordering Guide 9.1.2.18. Note: Will be V to indicate conversion to another local service provider or C for INP to LNP conversion or W for Conversion Listing as Is (LNP Full Migrations Only)
SUP	Supplement Type	Refer to CLEC Ordering Guide 9.1.2.19 Note: This field is conditional. When submitting a supplement (SUP) LSR, this field must be populated.
CC	Company Code	Refer to CLEC Ordering Guide 9.1.2.23 Note: This code must be the code used for the NPAC and for CLEC Q-accounts. The CC is also known as the four digit OPERATING COMPANY NUMBER (OCN)
ACTL	Access Customer Terminal Location	Refer to CLEC Ordering Guide 9.1.2.30 Note: Required for orders with designed loop.
LSO	Local Service Office	Refer to CLEC Ordering Guide 9.1.2.34 Note: Required for loop orders or when a directory listing is requested on the end user telephone number which is from a CLEC assigned NPA NXX.

- continued -

Table E LSR Minimal Required Fields for Faxed Orders (LNP Port-out With or Without Loop) (continued)

Field Abbreviation	Field Name	Explanation
TOS	Type of Service	Refer to CLEC Ordering Guide 9.1.2.35 Note: Identifies type of service (business, residential, or government) for the existing account which is porting out. Note: Be sure to use D as the second character for Complex service.
NC	Network Channel	Refer to CLEC Ordering Guide 9.1.2.37 Note: Required for loop orders.
NCI	Network Channel Interface	Refer to CLEC Ordering Guide 9.1.2.38 Note: Required for designed loop orders.
SECNCI	Secondary Network Channel Interface	Refer to CLEC Ordering Guide 9.1.2.40 Note: Required for designed loop orders.
CIC	Carrier Identification Code	Refer to CLEC Ordering Guide 9.1.2.48
CUST	Customer Name	Refer to CLEC Ordering Guide 9.1.2.49
BAN1	Billing Account Number 1	Refer to CLEC Ordering Guide 9.1.2.51
ACNA	Access Customer Name Abbreviation	Refer to CLEC Ordering Guide 9.1.2.54 Note: Required for orders with loop.
TE	Tax Exemption	Generated by BST
INIT	Initiator Identification	Refer to CLEC Ordering Guide 9.1.2.69
TEL NO (INIT)	Telephone Number	Refer to CLEC Ordering Guide 9.1.2.70
FAX NO	Initiator Fax Number	Refer to CLEC Ordering Guide 9.1.2.72 Note: Required to send FOC via fax
STREET	Initiator Street Address	Refer to CLEC Ordering Guide 9.1.2.73
CITY	City	Refer to CLEC Ordering Guide 9.1.2.76

- continued -

Table E LSR Minimal Required Fields for Faxed Orders (LNP Port-out With or Without Loop) (continued)

Field Abbreviation	Field Name	Explanation
STATE	State	Refer to CLEC Ordering Guide 9.1.2.77
ZIPCODE	Zip Code	Refer to CLEC Ordering Guide 9.1.2.78
MPCON	Implementation Contact	Refer to CLEC Ordering Guide 9.1.2.79 Note: : Required for orders with loop and for ACT of V (indicates conversion to another local service provider)
TEL NO	Telephone Number	Refer to CLEC Ordering Guide 9.1.2.80 Note: Required for orders with loop and for ACT of V (indicates conversion to another local service provider)
DRC	Design Routing Code	Refer to CLEC Ordering Guide 9.1.2.86 Note: Required on orders with non-designed loop when requesting a Loop Make-up.

Critical Fields on LSR

There are certain critical fields on the LSR that cannot be changed once the LSR has been validated. If these fields are to be changed, the first LSR must be canceled and a new LSR issued on a different PON. The critical fields are:

- PON
- CC
- ATN
- AN
- EATN
- EAN
- ACT
- NPT

4.4.2 Faxed End User Information Form Fields

Please review the notes for each field, as they may highlight common errors on LNP LSRs. The fields below are those required for LNP orders. They may be required, conditional, or optional for other types of orders

Table F Minimal Required Fields for Faxed End User Form

Field Abbreviations	Field Name	Explanation
PON	Purchase Order Number	Refer to CLEC Ordering Guide 9.2.2.1 Note: This entry must be identical to the PON entry on the LSR form.
VER	Version Identification	Refer to CLEC Ordering Guide 9.2.2.2 Note: This field is conditional. When submitting a supplement (SUP) LSR, this entry must be identical to VER entry on the SUP LSR.
PG__OF__	Page Number / Total Pages	Refer to CLEC Ordering Guide 9.2.2.6
NAME	End User Name	Refer to CLEC Ordering Guide 9.2.3.1
SANO*	Service Address House Number	Refer to CLEC Ordering Guide 9.2.3.4
SASN	Service Address Street Name	Refer to CLEC Ordering Guide 9.2.3.7
CITY	City	Refer to CLEC Ordering Guide 9.2.3.14
STATE	State / Province	Refer to CLEC Ordering Guide 9.2.3.15
ZIP CODE	Zip Code	Refer to CLEC Ordering Guide 9.2.3.16

Note: Depending on the address associated with the order, conditional address fields may be required to provide a complete and valid end user location.

Note: The CLEC must advise BellSouth how to handle additional telephone numbers on the end user account. The additional telephone numbers may be associated with features such as:

- Ringmaster
- Surrogate Client MemoryCall
- Flexible Call Forwarding Dial Around (FCPAN)

If these telephone numbers are not porting, use the disconnect section on the End User Form to detail this information.

4.4.3 Faxed Number Portability Form Fields

Faxed Number Portability Form Fields

Note: The PS Form must always be associated with the Local Service Request (LSR) and End User (EU) forms. Please review the notes for each field, as they may highlight common errors on LNP LSRs. The fields below are those required for LNP orders. They may be required, conditional, or optional for other types of orders.

Table G Minimal Required Fields for the Faxed Number Portability Form

Field Abbreviation	Field Name	Explanation
PON	Purchase Order Number	Refer to CLEC Ordering Guide 9.8.2.1 Note: This entry must be identical to the PON entry on the LSR form.
VER	Version Identification	Refer to CLEC Ordering Guide 9.8.2.2 Note: This field is conditional. When submitting a supplement (SUP) LSR, this entry must be identical to VER entry on the SUP LSR.
NPQTY	Number Portability Quantity	Refer to CLEC Ordering Guide 9.8.2.5
PG__OF__	Page Number / Total Pages	Refer to CLEC Ordering Guide 9.8.2.6
REF NUM	Reference Number	Refer to CLEC Ordering Guide 9.8.3.1 Note: REF NUMs must be unique on each form associated with the LSR. REF NUMs may not be duplicated and are associated with porting numbers, disconnecting numbers, and directory listings.

- continued -

**Table G Minimal Required Fields for the Faxed Number Portability Form
(continued)**

Field Abbreviation	Field Name	Explanation
LNA	Line Activity	Refer to CLEC Ordering Guide 9.8.3.3 Note: V= conversion of service to new LSP C= change existing account (e.g. INP to LNP)
PORTED #	Ported Telephone Number	Refer to CLEC Ordering Guide 9.8.3.7
NPT	Number Portability Type	Refer to CLEC Ordering Guide 9.8.3.10 Note: D= Local Number Portability

4.4.4 Faxed Loop Service with Number Portability Form Fields

Faxed Loop Service with Number Portability Form Fields

Note: The LSNP form must always be associated with the Local Service Request (LSR) and End User (EU) forms. Please review the notes for each field, as they may highlight common errors on LNP LSRs. The fields below are those required for LNP orders. They may be required, conditional, or optional for other types of orders.

Table H Minimal Required Fields for Faxed Loop Service with Number Portability Form

Field	Abbreviation Field	Name Explanation
PON	Purchase Order Number	Refer to CLEC Ordering Guide 9.10.2.1 Note: This entry must be identical to the PON entry on the LSR form.
VER	Version Identification	Refer to CLEC Ordering Guide 9.10.2.2 Note: This field is conditional. When submitting a supplement (SUP) LSR, this entry must be identical to VER entry on the SUP LSR.
LQTY	Loop Quantity	Refer to CLEC Ordering Guide 9.10.2.5
PG__OF__	Page Number / Total Pages	Refer to CLEC Ordering Guide 9.10.2.6

- continued -

Table H Minimal Required Fields for Faxed Loop Service with Number Portability Form (continued)

Field	Abbreviation Field	Name Explanation
REF NUM	Reference Number	Refer to CLEC Ordering Guide 9.10.3.1 Note: For LNP, REF NUMs must be unique on each form associated with the LSR. REF NUMs may not be duplicated and are associated with porting numbers, disconnecting numbers, and directory listings.
LNA	Line Activity	Refer to CLEC Ordering Guide 9.10.3.3 Note: V= conversion of service to new LSP
SYSTEM ID	System Identification	Refer to CLEC Ordering Guide 9.10.3.8
CABLE ID	Cable Identification	Refer to CLEC Ordering Guide 9.10.3.11 Note: Required for port-out with loop orders. Note: Note: In some wire centers, CFA (Connecting Facility Assignment) may be used instead of cable ID and chain/pair. Refer to CLEC Ordering Guide 9.10.3.9
SHELF		Refer to CLEC Ordering Guide 9.10.3.12
SLOT		Refer to CLEC Ordering Guide 9.10.3.13
RELAY RACK		Refer to CLEC Ordering Guide 9.10.3.14

- continued -

Table H Minimal Required Fields for Faxed Loop Service with Number Portability Form (continued)

Field	Abbreviation Field	Name Explanation
CHAN / PAIR	Channel / Pair	Refer to CLEC Ordering Guide 9.10.3.15 Note: Identifies the customer's system to be used in a collocation arrangement. Required when the customer has assignment control in a collocation arrangement, otherwise prohibited. Note: Required for port-out with loop orders. In some wire centers, CFA (Connecting Facility Assignment) may be used instead of cable ID and chain/pair. Refer to CLEC Ordering Guide 9.10.3.9
PORTED #	Ported Telephone Number	Refer to CLEC Ordering Guide 9.10.3.23
NPT	Number Portability Type	Refer to CLEC Ordering Guide 9.10.3.26 Note: D= Local Number Portability

4.5 Complex LNP Orders

Definition of Complex Services

The Local Number Portability (LNP) request is classified as complex if the number(s) being ported out is working on a complex class of service. Requests to port out telephone numbers working on the following types of service are considered complex:

- ESSEX / MultiServ
- Primary Rate ISDN
- Basic Rate ISDN
- Channelized Megalink
- PBX - DID, Inward/Outward/Combination trunks
- Pathlink

4.6 Faxed Loop Service with Number Portability Fields

Faxed Loop Service with Number Portability Fields

Note: The LSNP form must always be associated with the Local Service Request (LSR) and End User (EU) forms. Please review the notes for each field, as they may highlight common errors on LNP LSRs. The fields below are those required for LNP orders. They may be required, conditional, or optional for other types of orders.

Field	Abbreviation Field	Name Explanation
PON	Purchase Order Number	Refer to CLEC Ordering Guide 9.10.2.1 Note: This entry must be identical to the PON entry on the LSR form.
VER	Version Identification	Refer to CLEC Ordering Guide 9.10.2.2 Note: This field is conditional. When submitting a supplement (SUP) LSR, this entry must be identical to VER entry on the SUP LSR.
LQTY	Loop Quantity	Refer to CLEC Ordering Guide 9.10.2.5
PG_OF_	Page Number/Total Pages	Refer to CLEC Ordering Guide 9.10.2.6
REF NUM	Reference Number	Refer to CLEC Ordering Guide 9.10.3.1 Note: For LNP, REF Nums must be unique on each form associated with porting numbers, and directory listings.
LNA	Line Activity	Refer to CLEC Ordering Guide 9.10.3.3 Note: V= conversion of service to new LSP N= new loop
System ID	System Identification	Refer to CLEC Ordering Guide 9.10.3.8

4.7 Project Managed LNP Orders and Standard Intervals

Note: For information on project management and due date intervals, refer to BellSouth Products and Services Interval Guide Interconnection Services @ http://interconnection.bellsouth.com/guides/guides_html

5. Critical Success Factors for LNP Ordering

5.1 Pre-Order Information

1. CLEC can proactively check the following points in the LSR before submitting via fax, EDI, or TAG.
 - a. Customer address is RSAG valid and within the rate center;
 - b. NPA-NXX is marked portable in the LERG;
 - c. TNs on LSR match TNs on end user account;
 - d. Due Date intervals are based on BellSouth Standard Intervals.
2. CLEC must have a Q-account for each OCN registered with NPAC and stated on LSR. All new OCNs registered with NPAC should be updated with BellSouth and a Q-account should be established.
3. CLEC should use correct OCN. OCN used at NPAC must match OCN used in CC field on CSR and OCN for Q account in BAN field.
4. CLEC must obtain end-user authorization to request LNP before submitting LNP LSR.

5.2 LSR Order Forms for LNP

1. CLEC should complete all required fields. Refer to Section 4.2, Minimum Required Fields, in this Guide.
2. CLEC should provide previously unassigned PON on LSR.
3. If CLEC is porting on any day other than the Due Date stated on the FOC, the CLEC should send BellSouth a SUP LSR prior to the Due Date stated on the LSR. BellSouth will then send a revised FOC with the new due date to the CLEC.
4. Per the BellSouth Ordering Guide for CLECs, a REF NUM may not be duplicated on an individual PON. **REF NUMs are associated with:**
 - porting numbers
 - disconnecting numbers
 - directory listings

Example: If a REF NUM is used on the Directory Listing Request form, it may not be repeated on the Number Portability/Loop form or the End User Disconnect form.

 - PONs containing duplicate REF NUMs are placed in clarification.
5. The CLEC must advise BellSouth how to handle additional telephone numbers on the end user account. The additional telephone numbers may be associated with features such as:
 - Ringmaster
 - Surrogate Client MemoryCall
 - Flexible Call Forwarding Dial Around

If these telephone numbers are not porting, use the disconnect section on the End User Form to detail this information.

6. For all LNP orders, the LSR must provide the initiator's fax number in the FAX NO field, even for EDI or TAG LSRs.
7. CLEC should provide accurate cable & pair information for loop orders to avoid provisioning delays.
8. An LSR must contain numbers on one CSR. An LSR must be sent for each CSR..

5.3 Supplemental LSRs

1. If CLEC intends to port on any day other than the Due Date stated on the FOC, the CLEC should send BellSouth a SUP LSR prior to the due date originally stated on the FOC.
2. A supplemental change LSR (SUP) must reflect the same PON, CC, ATN, AN, EATN, EAN, ACT, and NPT as the original request.
3. SUP must also have a higher VER number and SUP field entry complete
4. EDI/TAG vs. FAX: EDI or TAG and Fax requests may not be combined for the same PON. If an LSR is submitted via:
 - EDI all SUPs for the PON must be sent through EDI.
 - TAG all SUPs for the PON must be sent through TAG.
 - Fax all SUPs for the PON must be faxed.

Example: The original LSR is sent via EDI and then placed in clarification by the LCSC. CLEC must send a SUP through EDI to change or cancel the request.

5.4 Clarifications

1. The CLEC has 10 business days to respond to the request for clarification by submitting a supplemental LSR.
2. If no response is received by BellSouth LCSC within 10 business days, the LSR will be canceled on the eleventh business day.
3. If original LSR is canceled by BellSouth, a new LSR with new PON must be submitted.
4. CLEC should not send Create SV to NPAC until an FOC has been received.
5. BellSouth will place SVs in Conflict if CLEC sends Create before FOC is received.

5.5 Standard Intervals

1. CLEC should review BellSouth Standard Interval Guide prior to submitting LSR.
2. The minimum Due Date for port-out is five business days after the FOC receipt date. The first TN ported in an NPA-NXX is no earlier than five business days after FOC receipt date.

5.6 NPAC Communication

1. CLEC must receive FOC from BellSouth prior to sending any NPAC SV messages (Create or Modify).
2. The CLEC should send the Create SV immediately upon receipt of FOC.
3. The Due Date on the Create SV sent to NPAC by the CLEC must match Due Date on FOC sent by BellSouth
4. The Due Time on the Create SV must be set to 00:00.
5. CLEC should send Activate SV to NPAC on FOC due date.
6. BellSouth LCSC does not issue the Disconnect service order until notification of CLEC Activate SV is received from NPAC for all TNs on the LSR. This is done to avoid disruption to end-user service.
7. For any change in the Due Date to port numbers, to cancel port, or to add/remove telephone numbers, a SUP LSR must be sent to BellSouth LCSC and CLEC must receive revised FOC prior to sending a Modify message to NPAC.

5.7 E911 Lock Down

1. CLEC must send Activate SV to NPAC before BellSouth LCSC will issue the Disconnect.
2. BellSouth will not send the Unlock Message until Disconnect service order is complete.
3. If CLEC Migrate message reaches SCC before BellSouth's Unlock Message, the CLEC Migrate message will be shown on an error report which is sent to CLECs daily. CLEC must be sure they have sent Activate SVs to NPAC for all TNs which appear on error reports from SCC. (Refer to Section 7.2 of this guide for more details)
4. CLEC and BellSouth should send Migrate and Unlock messages to SCC with the same due date as the Activate SV to NPAC.

6. System Interfaces

6.1 Interface Options for Order Submission

Ordering Options for LSRs

The CLEC must send the Local Service Request (LSRs) for Local Number Portability or Loop Service with Number Portability to the BellSouth LCSC for processing. The request may be faxed or sent electronically through Electronic Data Interchange (EDI) or Telecommunication Access Gateway (TAG).

If the LSR is received electronically, the FOC is sent to the CLEC automatically through EDI or TAG. The CLEC also receives completion notices through EDI or TAG once the service orders are complete. EDI, TAG and Fax requests may not be combined on the same PON. If an LSR is originally submitted via EDI, then all SUPS for this PON must be sent through EDI.

For further information on EDI, refer to **BellSouth Ordering Guide for CLECs**, Section 6.2.1 on Electronic Data Interchange. (EDI)

6.2 System Interface Descriptions

Local Exchange Navigational System (LENS)

Step	Action
Description	Front-end GUI application which provides pre-ordering support for LNP orders using the Inquiry function.
Inputs	Customer address, customer information
Outputs	RSAG Address Validation Service availability for a particular NPA NXX Customer record information
Notes	LNP LSRs <u>can</u> not be submitted via LENS.

PON Order Status via the Web

Step	Action
Description	Supports on-line viewing of faxed LSR order status.
Inputs	Faxed LSRs
Outputs	CLEC-specific LSR status by PON
Notes	For faxed LSRs

Fax

Step	Action
Description	Supports the transmission of manual CLEC orders.
Inputs	Paper LSR
Outputs	Clarifications; FOCs
Notes	Clarifications and FOCs for faxed LSRs are sent via fax. SUP LSRs for faxed LSRs must be submitted via fax. EDI, TAG and faxed requests may not be combined on the same PON.

Electronic Data Interchange (EDI)

Step	Action
Description	Supports the CLEC transmission of orders to BellSouth, and the acknowledgment of receipt of orders to CLEC by BellSouth.
Inputs	Digital LSR
Outputs	Clarifications; Rejects, FOCs, Pending Order Statuses, Completion Notices

Telecommunications Access Gateway (TAG)

Step	Action
Description	Supports the CLEC transmission of orders to BellSouth, and the acknowledgment of receipt of orders to CLEC by BellSouth. CLEC has access to ordering and pre-ordering functionality via TAG.
Inputs	Digital LSR
Outputs	Clarifications; Rejects, FOCs, Pending Order Statuses, Completion Notices

BellSouth LNP Gateway

Step	Action
Description	Supports both internal and external communications with various interfaces and processes, including NPAC (SOA & SMS), EDI, and TAG.
Inputs	· LNP LSRs, NPAC messages, EDI and TAG orders
Outputs	Rejects; Clarifications; FOCs NPAC concurrence messages Service orders to provisioning

NPAC

Step	Action
Description	NPAC is the third party organization that oversees the porting of telephone numbers for Local Number Portability.
Inputs	CLEC and BellSouth subscription versions.
Outputs	CLEC and BellSouth subscription versions.

Note: Interface descriptions are specific to LNP orders only.

7. Frequently Asked Questions

7.1 General

1. 1. What should be done if it is determined that some numbers sent on an LSR are not to be ported?

A sup should be sent immediately to delete the telephone numbers from the NP or LSNP form if they are not porting. The account will not be disconnected until all telephone numbers on the NP or LSNP form have been ported.

2. 2. How is a CLEC LSR validated?

The validation process includes the following steps to ensure that the requested number(s) may be ported out.

Step	Action
1	Are the porting number(s) on the LSR working number(s) on the CSR (or customer is paying to reserve the numbers)? If yes, go to step 2. If no, go to step 7.
2	Does the end user name on the LSR match the listed name and/or billing name on the CSR? If yes, go to step 3. If no, go to step 7.
3	Are the telephone number(s) on the LSR associated with a line type that is portable? Refer to Local Number Portability Rules (Section 4.2 of this guide). If yes, go to step 4. If no, go to step 7.
4	Does the service address information on the LSR match the LA or SA on the CSR? If yes, go to step 6. If no, go to step 5. Note: If the line type on the existing end user service is FX/FCO, go to step 5.
5	Is the Toll Message Rate Center (TMRC) for the porting number(s) shown on the LSR the same as the TMRC for the address shown on the LSR? If yes, go to step 6. If no, go to step 7.
6	Is LNP available for the NPA NXX at this time? If yes, go to step 8. If no, go to step 7.
7	Send CLEC Clarification request and wait for receipt of SUP LSR.
8	Proceed with Service Order Issuance Process.

3. What CLEC actions would cause an LNP request to fall out of the order process at BellSouth?

Some reasons for an LSR to fall out of the order process are:

- CLEC sent a create SV before receiving an FOC. BellSouth will put SV in Conflict with NPAC

- CLEC sent a create on the wrong TN
- CLEC sent create with due date different than FOC due date
- CLEC sent create with time other than 00:00
- CLEC ported number before or after Due Date on the FOC

If the CLEC LSR has fallen out of the order process, BellSouth will not be able to automatically send Concur SV to the CLEC Create SV.

- 4. What CLEC actions should be taken if the end user is continuing to receive a bill from BST after the account is ported out?
- CLEC should verify that the activate SV has been sent on all telephone numbers provided on the LSR. If yes, refer the account to the LCSC for investigation. If no, send the activate SV to the NPAC.

7.2 Ordering Options

1. In what form should a CLEC expect to receive an FOC, Clarification, or Reject response?
 - If an order was sent via EDI, the response will be sent via EDI.
 - If an order was sent via TAG, the response will be sent via TAG
 - If an order was sent via fax, the response will be sent via fax.
2. Why can't the status of an LSR submitted via EDI be viewed in the PON Status Reports which are available on-line?

The PON Status Reports are for orders which were submitted via fax. Status for orders submitted via EDI/TAG are received via EDI/TAG.

7.3 LSR Error Notices

1. What types of errors would require clarification?

Some examples of errors for which BellSouth will request clarification:

- Some numbers on an account are being ported, but information/instruction has not been provided on **ALL** numbers listed on the account (i.e., Ringmaster; Surrogate Client MemoryCall; Flexible Call Forwarding Dial Around (FCPAN))
- REF NUM are duplicated on the LSR
- LSR does not contain the minimum required fields
- Duplicate PON
- Data was entered into a prohibited field
- Busy cable & pair
- Incorrect address
- End user & central office are not in same wire center (may be wrong ACTL)
- Invalid ACT
- Invalid Q-account

- TN listed is not a working BellSouth TN
 - Listing 2 numbers to port from two different CSRs on one LSR
2. Why would the CLEC receive error reports from SCC, Manager of the E911 database?
If the CLEC sends the Migrate message to the SCC to lock E911 prior to SCC receiving BellSouth's Unlock message, the CLEC Migrate message will be placed on an error report (755) which is distributed daily to CLECs from SCC. SCC will mechanically process the Migrate/Unlock record match for 7 days for all 755 error messages. After 7 days the record will move to a 760 error file. SCC will manually continue to look for the record match there. CLEC should be sure that the Activate SV has been sent to NPAC for the Migrate messages which appear on the 755 or 760 error reports.

7.4 Due Dates

1. What are the key steps to changing the Due Date for a previously submitted LNP LSR?
The most important part of a Due Date change is submitting a SUP LSR to the BellSouth LCSC and receipt of a revised FOC prior to sending the Modify SV to NPAC. If the Modify SV is sent to NPAC prior to receipt of the revised FOC from BellSouth, the LSR will fall out of the order process at BellSouth. Due Date changes should be requested prior to the due date and not later than the due date originally stated.
2. Why does the FOC have a Due Date which is different than the Desired Due Date?
If the Desired Due Date on the original LSR did not adhere to BellSouth Standard Intervals for LNP orders, then the Due Date on the FOC would reflect the appropriate interval. Refer to BellSouth Standard Interval Guide for more details.
3. Why does the CLEC have to send the Activate SV on the Due Date?
If the CLEC sends the Activate SV before or after the Due Date on the FOC, end user service could be impacted.

7.5 NPAC Communication

1. What does it mean when a CLEC receives an SV with Authorization set to NO (Conflict) from NPAC?
This SV indicates that the CLEC sent a Create SV to NPAC prior to receipt of an FOC for the TN. CLEC should check for receipt of an FOC for the TN.
2. Why can't the CLEC send the Create SV to NPAC prior to receiving an FOC from BellSouth?
If the CLEC sends the Create SV to NPAC prior to receiving an FOC from BellSouth, BellSouth will send SV with Authorization set to NO (Conflict) to NPAC. CLEC should follow industry flow for successful porting.
3. How does CLEC know BellSouth is ready to port number?
CLEC should complete the following steps at least the day before the due date:
- verify FOC was received
 - verify FOC due date
 - verify SV is Pending with Concurrence for all TNs on LSR

- verify SV due date is same as FOC due date for all TNs on LSR
4. What happens if the NPAC telephone number disconnect option is used after sending the activate (number ported) message?
- The telephone number and not the end user is returned to BellSouth. The CLEC must arrange to provide service for the end user because upon receipt of the Activate SV, BST will proceed with the disconnect order.

8. LNP Ordering Checklist

8.1 LNP Ordering Checklist

1. Pre- Submission: The LSR Form for LNP

Has the pre-order information been validated? CLECs may access pre-order support using a web browser and the LENS interface. Use the Inquiry function to confirm the accuracy of the following information:

- TNs on LSR match TNs on CSR
 - LSR address is RSAG valid
2. Have you included/checked the following items:
 - Previously unassigned PON on LSR
 - Unique REF NUMs on all associated forms for LSR
 - Minimum required fields are complete
 3. Is there a Q-account for each OCN registered at the NPAC and stated on the LSR in the CC field?
 4. Were BellSouth Standard Due Date Intervals followed when assigning the Desired Due Date? (Refer to BellSouth Products and Services Interval Guide.)

5. NPAC Communication

Do not send NPAC messages (e.g., Create or Modify) prior to receipt of FOC. (For original LSR or SUP LSR)

6. The Create SV should be sent immediately upon receipt of FOC by the CLEC for all TNs on the LSR.
7. Does the Due Date on Create message must match Due Date on FOC sent by BST?
8. For any change in the Due Date to port numbers, a SUP LSR must be sent to BellSouth LCSC prior to sending a Modify message to NPAC. Any other changes, such as Cancellations, also require a SUP LSR.
9. Does the Due Time have setting of 00:00?

10. E911 Lockdown

The Migrate message to lock records at an E911 SCC should be sent after the Activate message is sent to NPAC.

Note: This list is not all inclusive, but highlights the actions which would most contribute to the submission of a valid LSR.

9. Glossary of LNP Terms

9.1 Glossary of LNP Terms

Advanced Intelligent Network (AIN)	Evolving, service-independent network architecture that provides important new capabilities for rapid creation of customized telecommunications services. AIN offers one way for a network element to query a central database to obtain local number portability routing information.
BST	Acronym used to indicate BellSouth.
Central Office (CO)	An environmentally controlled space in which a telecommunications network switching system and other associated operating systems are installed.
Central Office Exchange (CENTREX)	A telephone service offered by LSPs that provides the end-user with advanced features and services from the LSPs EO
Clarification	Requested by BellSouth LCSC when an CLEC LSR contains incomplete or inaccurate information which requires further documentation from the CLEC to allow order processing to continue.
Competitive Local Exchange Carrier (CLEC)	A new entrant into a market where there is already an incumbent LEC (ILEC) providing local phone service.
Conflict	An SV status which indicates that an error has occurred in the ordering process which will require further CLEC action for BellSouth to resume order processing. For example, BST will place SV in conflict if CLEC sends a Create SV before an FOC has been issued.
Directory Number (DN)	An end-user's telephone number, also known as a TN. In its most restrictive definition, an end-user number which is listed in a directory or with directory assistance.
Donor Switch	Switch/Office/Exchange Refers to the local switch from which an end-user was served, prior to changing SPs.

End Office (EO)	A switching system used to provide local service for a local telephone company; also known as a central office. End offices are typically equipped with both line and trunk terminations.
Fall-Out	Human eyes are needed to review the order, e.g. with a partial migration.
Fatal Reject	A type of error which suggests that the minimal requirements of an LSR were not fulfilled. For example, a missing required field or a duplicate PON. A Fatal Reject will not allow the CLEC order to be processed further by the BellSouth LCSC.
Federal Communications Commission (FCC)	Congressionally credited governmental agency with the responsibility to direct the U.S. national and international telecommunications regulatory environment.
Firm Order Confirmation (FOC)	Verification/acknowledgment from one SP to another of receipt of a valid Local Service Request (LSR)
Incumbent Local Exchange Carrier (ILEC)	Typically, the RBOC or independent who services local end-users (prior to a market opening up to local competition)
Intelligent Network (IN)	Hardware and software platform used to provide enhanced voice, video and data services. IN offers one way for a network element to query a central database to obtain local number portability routing information.
Inter-Exchange Carrier (IXC)	A carrier that provides connections between LATAs, between serving areas, and between LATAs and serving areas where the calling or called end-user is located in the United States.
Interim Number Portability (INP)	A temporary solution for porting telephone numbers that routes calls to the CLEC wire center using: <ul style="list-style-type: none">• Remote Call Forwarding (RCF)• Direct Inward Dialing (DID)• Route Index Hubbing (RTI)
Local Exchange Carrier (LEC)	A company that provides local telephone service. LECs also include independent local telephone companies.

Local Exchange Routing Guide (LERG)	Bellcore administered Network Routing and V&H Coordinate information for U.S. Telecommunications Industry and others.
Local Number Portability (LNP)	Provides end users with the ability to retain their numbers when they change their local service provider.
Local Number Portability Gateway (LNP GW)	A BellSouth System created to support LNP that: <ul style="list-style-type: none">• includes desktop application for LCSC Service Representatives.• is used to process LNP LSR's on-line.• communicates with the NPAC.• interfaces with the AIN database to update call routing information.
Local Service Management System (LSMS)	The LSP owned network database which holds downloaded ported number information.
Local Service Provider (LSP)	A company that provides basic local telephone service.
Location Routing Number (LRN)	A routing code that is: <ul style="list-style-type: none">• unique• 10 digits• identifies the switch in which a ported number resides. LRN utilizes AIN triggers, SS7 signaling, and unique 10-digit code for switch identification.
Lockheed-Martin IMS (LM-IMS)	The neutral third-party administrator for the LNP database NPAC.
New Service Provider (NSP)	Subscribers selection of exchange carrier that will be providing dial tone. This will usually be the exchange carrier that is not the default SP for the NPA NXX. This would be the recipient switch for the porting of a number when the end-user is being ported. When the end-user is changing from ported to non-porting the NSP would be the donor switch.
Non-Portable Number	Numbers are those that have not been designated as ported exchanges or portable capabilities in the LERG.
North American Numbering Council (NANC)	FCC -mandated task force assigned to oversee NPAC and NANP administration for the U.S. telecommunications industry.

North American Numbering Plan (NANP)	A plan for the allocation of unique 10 digit address numbers. The numbers consist of a 3 digit area (numbering plan area) code, a 3 digit office code, and a 4 digit line number. The plan also extends to format variations (e.g., 3 digit and 7 digit address), prefixes (e.g., 1, 0, 01 and 011), and special code applications (e.g., Service Access Codes).
Number Portability Administration Center (NPAC)	A neutral third party vendor contracted by BellSouth and the CLEC's to: <ul style="list-style-type: none">• maintain the master database for LNP.• coordinate the flow of information between service providers.
Numbering Plan Area (NPA)	A defined geographic area identified by a unique three digit code used in the North American Numbering Plan Area.
NXX	End Office Code A three digit code used to identify a central office exchange. However, in a portable environment the last 4 digits or the 7-digit telephone number may not always reside in the central office exchange to which the NXX was natively assigned.
Plain Old Telephone Service (POTS)	Basic residence or business telephone service which provides users with simple telephone features or service.
Port In	A term used with Local Number Portability to indicate that a customer is changing his facility based local service provider from a CLEC to BellSouth and wishes to keep his same telephone number.
Port Out	A term used with Local Number Portability to indicate that a BellSouth customer is taking his telephone number with him to another facility based local service provider.
Portability	The ability of the user to change local telephone companies, location and/or service without changing the telephone number.

Portable Number	Those numbers within an exchange that have portable capabilities and are assigned to a designated portable exchange. These are the numbers that are assigned to the designated default switch and have not been ported to another LSP. These numbers are commonly identified as working on the "Donor" switch. Portable numbers are all numbers in an NXX where portability is allowed. Numbers will be declared portable on an NXX basis.
Ported Number	Those that have been assigned to other LSPs providing recipient switch access for Portable exchanges. This is commonly termed as the numbers assigned to the "Recipient" switches. The "Recipient" switch is not the default switch in the SCP. Ported numbers are the subset of portable numbers that have actually been moved from the LERG based switch (donor) to another switch (recipient).
Private Branch Exchange (PBX)	System typically installed in a business that serves as the central telephone system for that business and which may provide certain enhanced services for that business.
Recipient Switch	Switch/Office/Exchange — Refers to local end office switch to which an end-user is served, after changing SPs.
Remote Call Forwarding (RCF)	LNP deployment model generally viewed as an interim solution. For customers changing their local telephone company and wanting to keep their phone number, routes all incoming calls to the old company switch first. Then the calls are forwarded to a new phone
SCC	Neutral third party responsible for the E911 database administration. (SCC is not an abbreviation.)
Service Management System (SMS)	Computer facility permitting access to records contained in the number portability database. Receives Number Ported messages from NPAC.
Service Order Administration (SOA)	Interface to the NPAC for porting end-user TNs. Receives create and sends concurrence SVs.
Service Provider (SP)	A company that provides telephone service.
Subscription Version (SV)	A message that flows through the NPAC to provide information regarding LNP.

Telecommunications Access Gateway
(TAG)

TAG is a transaction based messaging system with data translation. TAG provides a by-directional flow of information between the CLEC and BellSouth, and gives the CLEC access to pre-ordering and ordering functionality.

Toll Message Rate Center (TMRC)

A uniquely defined geographic area:

- created to allow for the proper rating of toll and message charges.
- appears in LERG for a wire center/switch.

Trigger Order

6-Digit Trigger – identifies NPA XXX that is portable and causes querying. 10-Digit Trigger – end-users' telephone number. This trigger causes look up process so when the 10-digit trigger is dialed the call is routed through AIN to the SS7 database.

Note: "Trigger" is not available for all service types.