

COMMONWEALTH OF KENTUCKY
BEFORE THE PUBLIC SERVICE COMMISSION

In the Matter of:

KENTUCKY UTILITIES COMPANY)
_____))
ALLEGED FAILURE TO COMPLY WITH) CASE NO. 98-275
ADMINISTRATIVE REGULATION)
807 KAR 5:041, SECTION 3)

O R D E R

Kentucky Utilities Company ("KU"), a Kentucky corporation which engages in the distribution of electricity to the public for compensation for lights, heat, power, and other uses, is a utility subject to Commission jurisdiction. KRS 278.010(3)(a).

KRS 278.280(2) directs the Commission to prescribe rules and regulations for the performance of services by utilities. Pursuant to this statutory directive, the Commission promulgated Administrative Regulation 807 KAR 5:041, Section 3, which requires electric utilities to maintain their plant and facilities in accordance with the standards of the National Electrical Safety Code (1990 edition) ("NESC").

Commission Staff has submitted to the Commission a Utility Accident Investigation Report dated August 14, 1997, appended hereto, in which Commission Staff alleges:

1. On June 19, 1997, Danny Luck was injured while setting a utility pole near the KU Tunnel Hill Substation in Robards, Kentucky.

2. At the time of the incident, a KU work crew consisting of Luck, Shea Davis, Rodney Roberson, Mike Schuette, and Tony Bingham were setting a 35-foot utility pole on an energized 3-phase 7,200 volt circuit at the entrance of KU's Tunnel Hill Substation.

3. At the time of the incident, the KU crew had covered the center phase and road phase of the 7,200 volt circuit with line hose and had tagged out the field phase. Using an extendo stick, Davis held the primary phase out of the way. Roberson operated a digger derrick truck which held the new utility pole in place while Bingham shovelled dirt around the pole and Luck tamped that dirt with a hydraulic tamper.

4. After installing the utility pole, the KU crew began removing and storing its equipment. While Roberson removed the derrick truck's boom from the 3-phase circuit, the pole grabber assembly at the end of the boom penetrated the line slot on the underneath side of the line hose. As a result, the truck became energized. At the time, Luck was storing the hydraulic tamper on the derrick truck. He received an electric shock and suffered burns to his right hand.

5. At the time of the incident, the derrick truck was not grounded and Luck was wearing only work gloves.

6. At the time of the incident, Schuette was in charge of the work site.

7. At the time of the incident, Luck and Schuette were KU employees and were acting within the scope of their employment.

8. NESC Rule 422A1 requires that, inter alia, when setting poles in or in the vicinity of energized lines, employees shall wear suitable insulating gloves.

9. NESC Rule 422A2 requires that contact with trucks, or other equipment which are not bonded to an effective ground, being used to set poles in or in the vicinity of energized lines shall be avoided by employees standing on the ground or in contact with grounded objects unless employees are wearing suitable protective equipment.

10. Luck failed to comply with NESC Rules 422A1 and 422A2.

11. Schuette failed to see that all safety and operating procedures were observed by those under his direction. His failure is a violation of NESC Rule 421A which requires a person in charge to adopt such precautions as are within his authority to prevent accidents and to see that all safety rules and operating procedures are observed by those under his direction.

Based on its review of the Utility Accident Investigation Report and being otherwise sufficiently advised, the Commission finds that prima facie evidence exists that KU has failed to comply with Administrative Regulation 807 KAR 5:041, Section 3.

The Commission, on its own motion, HEREBY ORDERS that:

1. KU shall appear before the Commission on October 6, 1998, at 9:00 a.m., Eastern Daylight Time, in Hearing Room 1 of the Commission's offices at 730 Schenkel Lane, Frankfort, Kentucky, for the purpose of presenting evidence concerning the alleged violations of Administrative Regulation 807 KAR 5:041, Section 3, and of showing cause why it should not be subject to the penalties prescribed in KRS 278.990(1) for these alleged violations.

2. KU shall submit to the Commission within 20 days of the date of this Order a written response to the allegation contained in the Utility Accident Investigation Report.

3. The Utility Accident Investigation Report of August 14, 1997, a copy of which is appended hereto, is made part of the record of this proceeding.

4. Any motion requesting any informal conference with Commission Staff to consider any matter which would aid in the handling or disposition of this proceeding shall be filed with the Commission no later than 20 days from the date of this Order.

Done at Frankfort, Kentucky, this 27th day of May, 1998.

PUBLIC SERVICE COMMISSION

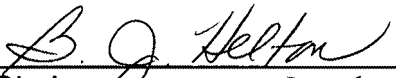
Chairman

Vice Chairman

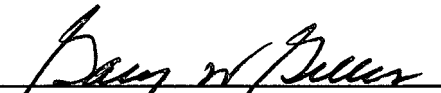
Commissioner

ATTEST:

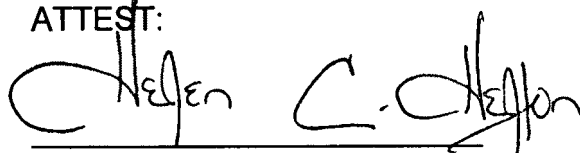
Executive Director

August 14, 1997

Page 1

**UTILITY ACCIDENT
 INVESTIGATION REPORT**

Utility:	Kentucky Utilities Company			
Reported By:	Carl Wise			
Dates & Times				
Accident Occurred:	06/19/97 - Approximately 11:30 a.m. (CST)			
Utility Notified:	06/19/97 - 12:45 p.m. (EST)			
PSC Notified:	06/19/97 - 2:02 p.m. (EST)			
Investigated:	06/20/97			
Written Report Rcvd:	06/24/97			
Location of Accident:	Kentucky Utilities Tunnel Hill Substation, 12990 HWY 416 West, Robards, KY			
Description of Accident:	<p>A Kentucky Utilities Company crew was in the process of setting a thirty-five foot pole in line on an energized three phase 7200 Volt circuit at the entrance of KU's Tunnel Hill Substation off HWY 416 West, when Danny Luck was injured. The crew had covered the center phase and road phase with line hose. The field phase had been tagged out and the primary neutral was being held out of the way with an extendo stick by Shea Davis. Rodney Roberson was operating the digger derrick truck and holding the pole in place while Tommy Bingham shoveled dirt around the pole. Danny Luck was tamping the dirt around the pole with a hydraulic tamper. Danny Luck finished his job and was putting the tamper back on the truck when he received a shock and burn to the heel of his palm on his right hand. At the same moment, Rodney Roberson was removing the truck's boom out of the three phase circuit, when the pole grabber assembly on the end of the boom inadvertently penetrated the line slot on the underneath side of the line hose causing the truck to be energized. The truck was not grounded and Danny Luck was wearing only work gloves. Mike Schuette was the supervisor on site and in charge at the time of the accident.</p>			
Victims:				
Name:	Mr. Danny Lee Luck	Fatal:	No	Age: 36
Addr./Empl.:	700 HWY 145, Pool, Kentucky/Kentucky Utilities Company			
Injuries:	Burns on heel of palm on right hand just below base of thumb			

Witnesses:	Name		Address/Employment		
	Mike Schuette		Kentucky Utilities, Morganfield & Dixon, KY		
	Danny Luck		Kentucky Utilities, Dixon, KY		
	Rodney Roberson		Kentucky Utilities, Morganfield, KY		
	James Taylor		Kentucky Utilities, Dixon, KY		
	Tommy Bingham		Kentucky Utilities, Morganfield, KY		
	Shea Davis		Kentucky Utilities, Dixon, KY		
Sources of Information:	Name		Address/Employment		
	Doug Mullins		Kentucky Utilities, Morganfield, KY		
	Ken Sheridan		Kentucky Utilities, Earlington, KY		
	Mike Schuette		Kentucky Utilities, Morganfield, KY		
	Danny Luck		Kentucky Utilities, Dixon, KY		
	Tommy Bingham		Kentucky Utilities, Morganfield, KY		
	Shea Davis		Kentucky Utilities, Dixon, KY		
Probable Violations:	NESC, 1990 Edition, Rule 421.A.1 & 2. General Operating Rules; Rule 422.A.1 & 2. Overhead Line Operating Procedures.				
Line Clearances At Point of Accident:	Measured	Minimum Allowed by NESC	Applicable NESC Edition¹ 1990	Volt.	Constr. Date
Phase Conductor to Ground Elevation:	FØ 29' - 4" CØ 29' - 9" RØ 29' - 5"	18' - 6"	1990	7200	1997
Primary Neutral Conductor to Ground Elevation:	17' - 9"	15' - 6"	1990	N/A	1997
Span Length:	261'				

¹ Current edition adopted by the Commission. If clearances are not in compliance with the current edition, then the edition in effect when the facilities were last constructed or modified would apply.

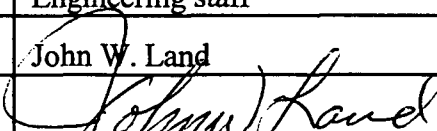
Date of Measurement:	06/20/97
Approximate Temp.:	Mid 80°F
Measurements Made By:	Mike Schuette and Larry Lee, Kentucky Utilities employees and John W. Land, PSC Engineering staff
Investigated By:	John W. Land
Signed:	

Attachments A. Kentucky Utilities Company's Accident Report
B. Photographs of Accident Site

Attachment A

Kentucky Utilities Company's Accident Report

Kentucky Utilities Company One Quality Street, Lexington, KY 40507-1462 Tel 606 255-2100

Utilities



Kentucky
Utilities
Company

June 23, 1997

RECEIVED

JUN 24 1997

DIVISION OF UTILITY
ENGINEERING & SERVICES

Mr. John Land
Public Service Commission
730 Schenkel Lane
P.O. Box 615
Frankfort, KY 40802

Dear Mr. Land:

SUBJECT: EMPLOYEE ACCIDENT - DANNY LUCK
DATE OF ACCIDENT: 06/19/97

Enclosed is a copy of a Report of Accident-Employee where Mr. Luck had his hand on truck after putting up Tamp when boom made contact causing shock and burn.

If you need additional information please advise.

Sincerely,

James A. Brackney, P.E.
Manager, Risk Management

JAB/ke
Enclosure
cc: Ron Willhite

E

REPORT OF INCIDENT - EMPLOYEE

KU 24-11

REV. 02/94

RECEIVE JUN 23 1997 6/23/97

Kentucky Utilities Co. Company 478 Hwy 41 A South Address Dixon KY 42409 City State Zip Location at which injured employee is regularly employed Dixon

Date of this report 6-19-97

Incident number

WHO WAS INJURED?

Name Danny Luck RISK MANAGEMENT DEPT. Sex M Age 36 Wage 21.15 Per (Hour/Week) Address 7000 Hwy 145 Poole KY 42444 Street City State Zip Area code and telephone number Married [X] Yes [] No Date of birth No. of children under 16 years 1 No. of dependents 2 List names, birthdates, relationship Lesa Luck Wife Dustin Luck Son Occupation Lineman Years employed by company 8 On present job 8 Social security no. Department District Crew Responsibility no. 148

TIME AND PLACE OF INJURY

Date 6-19-97 Hour 11:30 A.M. Did incident occur on employer's premises? [X] Yes [] No Place of incident Hwy 416 Cairo KY Street City State

WITNESSES TO THE INJURY

Name Address Phone 1. Mike Schuette Poole, KY 2. James Taylor Sebree, KY

NATURE AND EXTENT OF INJURY (Include All Injuries)

Parts of body injured Hand [] First Aid [X] Medical [] Modified Duty Days [] Lost Time Days Date of first treatment by doctor 6-19-97 Emergency room or attending physician Thaddeus Salmon Address 1305 N Elm St Henderson, KY Date hospitalized -- Name and address of hospital Community Methodist Hospital

INCIDENT

Identify object, substance or machine which directly injured employee Derrick Truck What was employee doing when injured? (Be specific) Had put Hydraulic Tamp on truck How did incident or exposure occur? (Tell what happened and how it happened) After putting up Tamp had hand on truck when Boom made contact. Describe events which resulted in injury

RECEIVED! JUN 24 1997 DIVISION OF UTILITY ENGINEERING & SERVICE

SIGNATURES

Employee's signature Danny Luck Date 6-19-97 Supervisor's signature Mike Schuette Date 6-20-97 Report approved by (Dist. Mgr. or Dept. Head) Date

FAX TRANSMISSION

KENTUCKY UTILITIES COMPANY

220 NORTH MORGAN STREET
MORGANFIELD, KY 42437
(502) 389-2911
FAX: (502) 389-3101

To: John Land Date: 6-23-97
Fax #: 1-564-1582 Pages: 3, including this cover sheet.
From: Jamie Blackburn
Subject: Employment History

COMMENTS:

This facsimile may contain information that is privileged and confidential and/or exempt from disclosure under applicable law. This transmission is intended solely for the individual or entity designated above. If you are not the intended recipient, or the employee or agent responsible for delivering it to the intended recipient, you should understand that any distribution copy or use of the information contained in this facsimile by anyone other than the designated recipient is unauthorized and strictly prohibited. If you have received this facsimile in error, please immediately notify the sender by telephone.

EMPLOYMENT HISTORY FOR

DANNY LEE LUCK

SOCIAL SECURITY NUMBER [REDACTED]

Employed July 24, 1989 as Line Technician B in the Earlington District Crew # 2

11-19-89 - Promoted to Line Technician A in the Earlington District Crew # 2 at Sebree

11-18-90 - Progressive Increase - Line Technician A

11-17-91 - Progressive Increase - Line Technician A

02-09-92 - Added the responsibility of material keeper - Line Technician A

EMPLOYMENT HISTORY FOR

RODNEY C. ROBINSON

SOCIAL SECURITY NUMBER [REDACTED]

Employed December 26, 1989 as Full time Custodian in the Morganfield District and Division Offices

12-30-91 - Transferred to the Division Construction Department as Line Technician C (Crew # 6)

01-10-93 - Progressive Increase - Line Technician C

03-07-93 - Transferred to the Morganfield District Crew as Line Technician C

06-27 93 - Promoted to Line Technician B in the Morganfield District Crew

06-26-94 - Progressive Increase - Line Technician B

06-27-95 - Progressive Increase - Line Technician B

12-24-95 - Promoted to Line Technician A in the Morganfield District Crew

KENTUCKY UTILITIES Co.
132 S. GREEN ST.
HENDERSON, KY 42420
502-826-1838
FAX: 502-827-9686

RECEIVED

JUN 26 1997

DIVISION OF UTILITY
ENGINEERING & SERVICES

June 24, 1997

John W. Land
Public Service Commission
P.O. Box 615
730 Schenkel Lane
Frankfort, Ky 40602

Dear John:

RE: Accident 06-19-97

Enclosed are the drawings made by Larry Lee of the accident site and the drawings of the truck involved, also enclosed is a copy of the system map of the substation where the accident occurred. This site was last inspected on 02-10-97. The address of the substation is 12990 Hwy 416W Robards, Ky.

The pole where the accident happened was intended to be a temporary pole and there is not specific print for this pole. The district superintendent and the foreman laid it out verbally with the district engineer.

I believe this will complete the list of information that you requested, if not please let me know.

Sincerely,



Doug Mullins
Safety Coordinator

Enclosure

APPROXIMATE LOCATION OF
WHERE HAND CAME INTO CONTACT
WITH TRUCK.

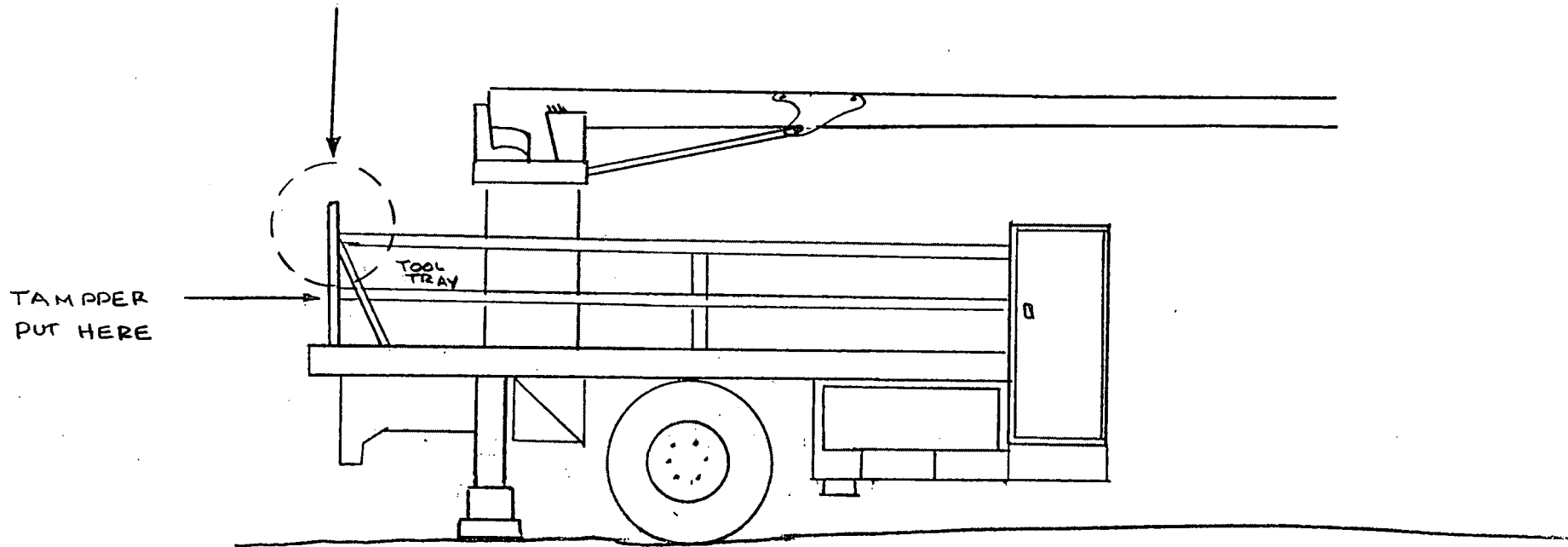

TAMPER
PUT HERE

POINT OF CONTACT WITH LINE
ON BACK SIDE.

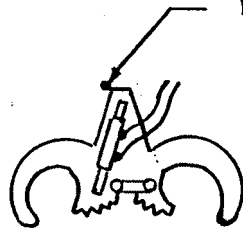

POLE
GRABBER

KENTUCKY UTILITIES CO.		
DANNY LUCK ACCIDENT		
DATE 6-19-97	SCALE NONE	BY L.I.K.L
SHEET NO	FILE NO.	

2

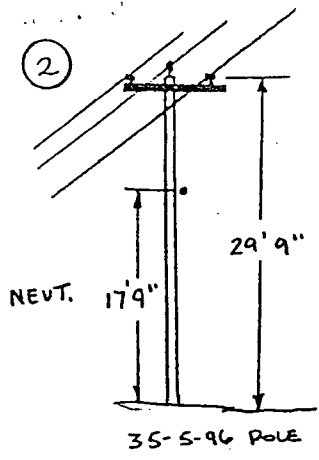

NOTE: NEUTRAL NOT ATTACHED TO POLE

3

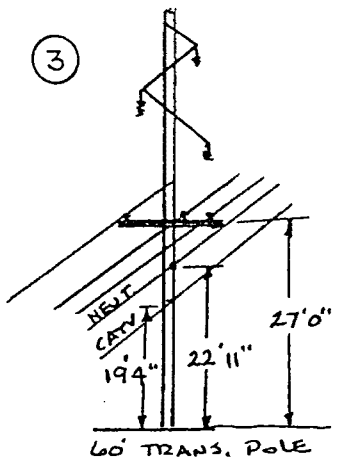

NOTE: POLE WAS BEING SET IN HOT 3 ϕ LINE WITH LINE HOSE ON CONDUCTORS

NOTE: POINT OF CONTACT WAS MADE ON THE TOP BACK SIDE OF GRABBERS

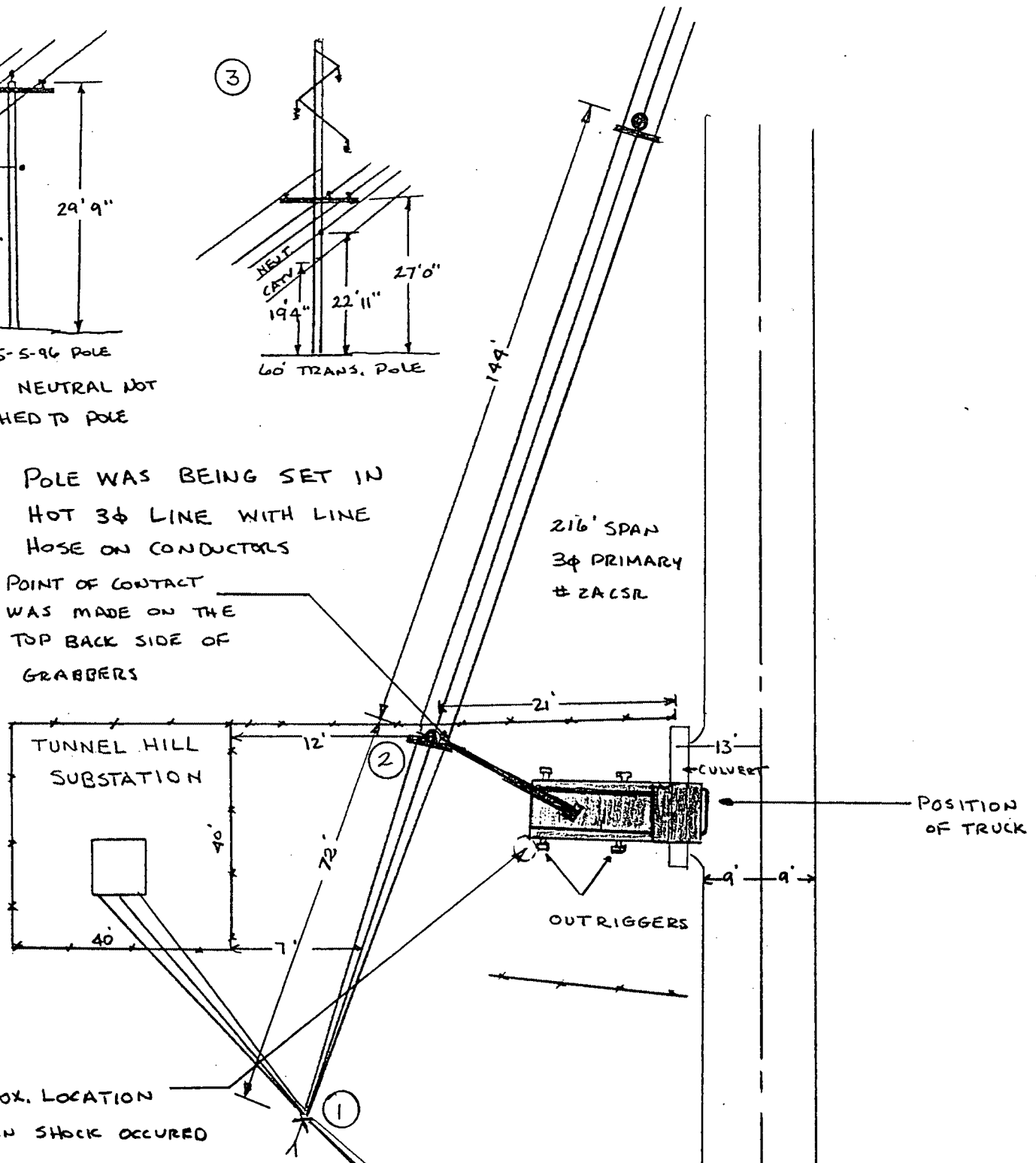

1

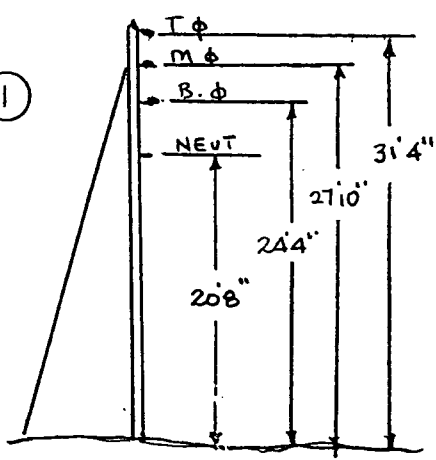

KENTUCKY UTILITIES CO		
DANNY LUCK ACCIDENT		
DATE 6-19-97	SCALE NONE	BY L.K.L.
SHEET NO	FILE NO.	

Attachment B
Photographs of Accident Site

