

# **Appendix F**

## **Process Flow Diagrams**

**E.W. Brown**

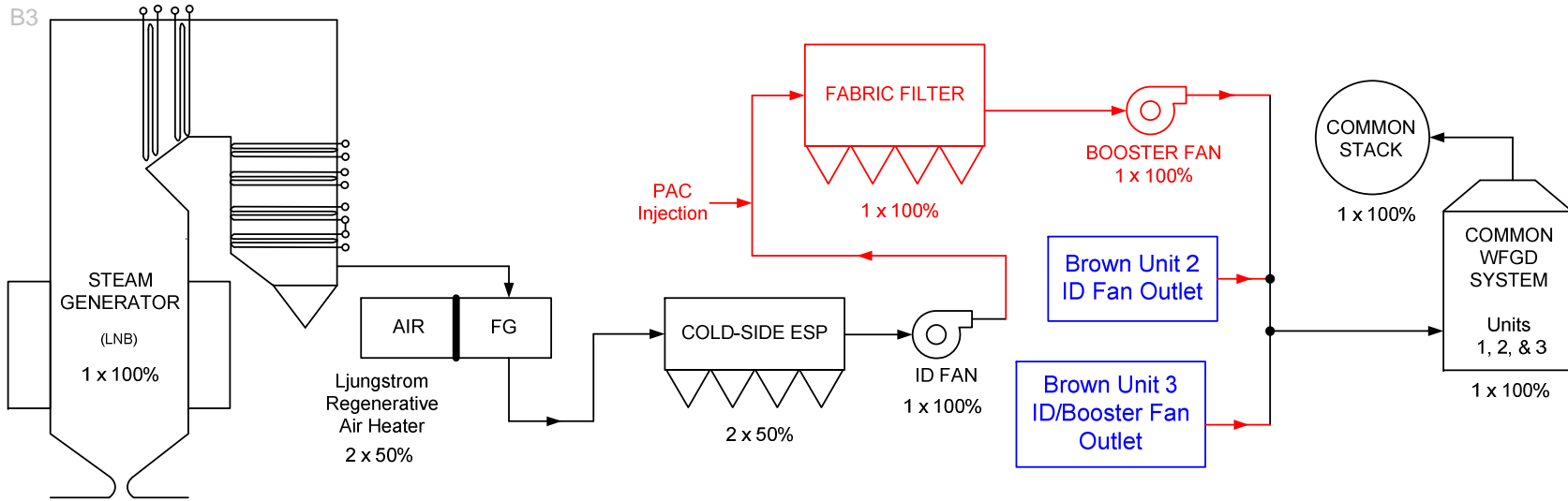

**Brown Unit 1: Future  
110 MW**

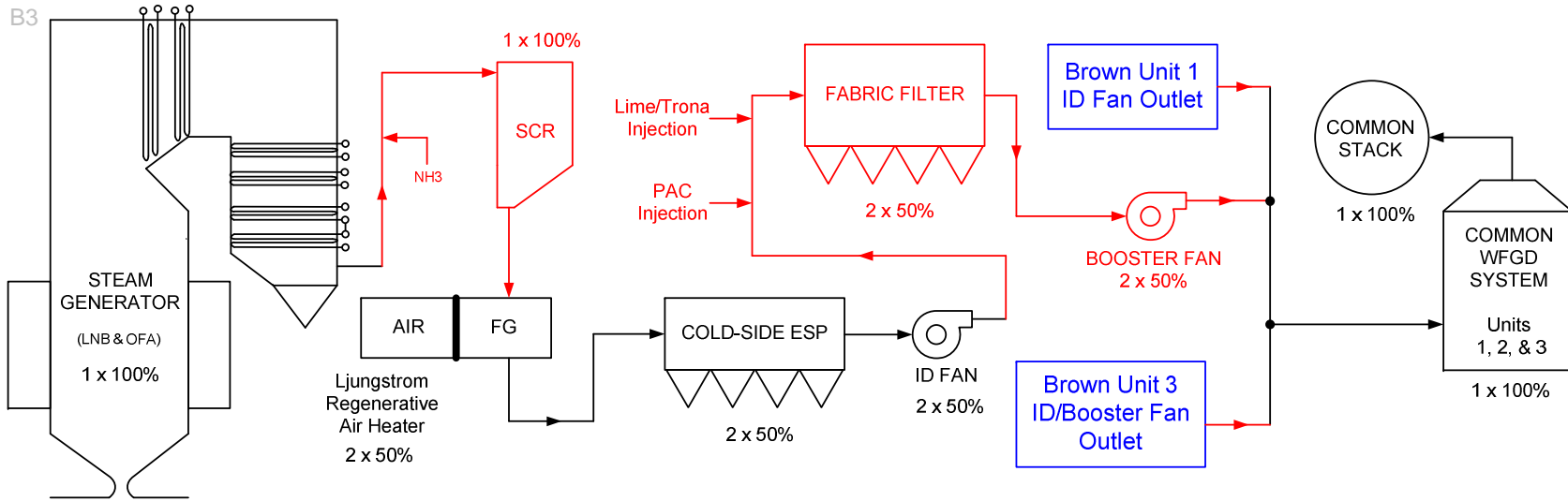

**Brown Unit 2: Future  
180 MW**

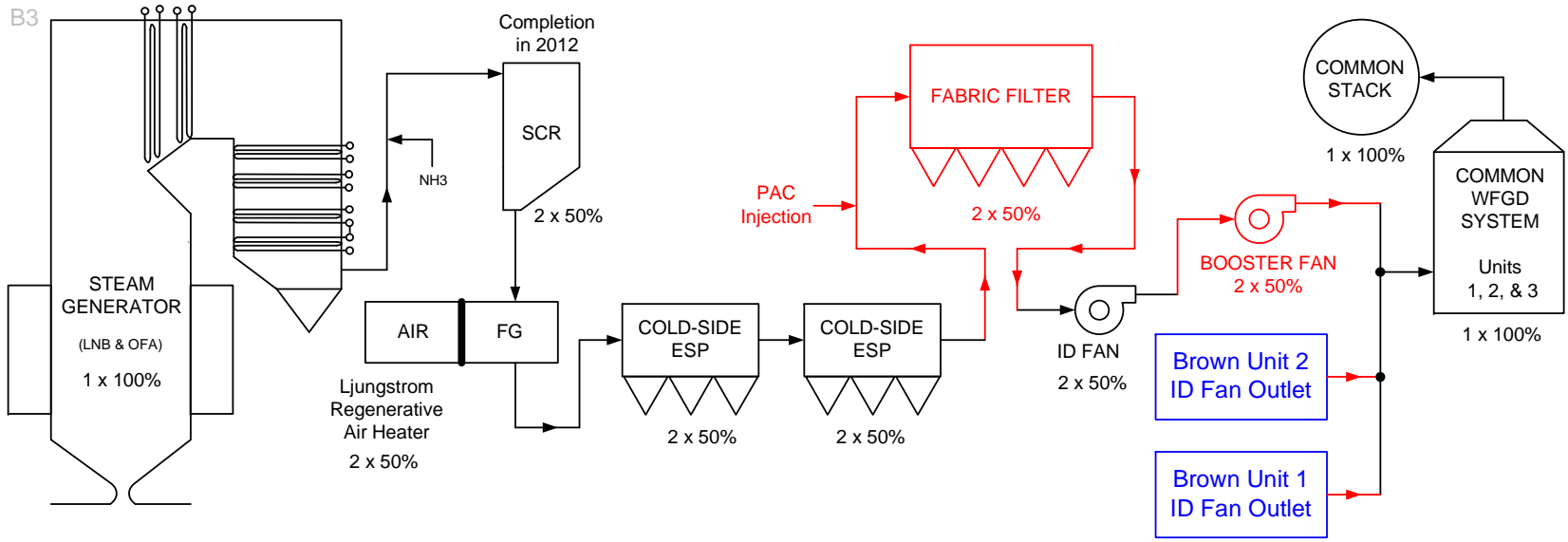

**Brown Unit 3: Future  
457 MW**

**E.W. Brown**  
**AQC Technology Options**

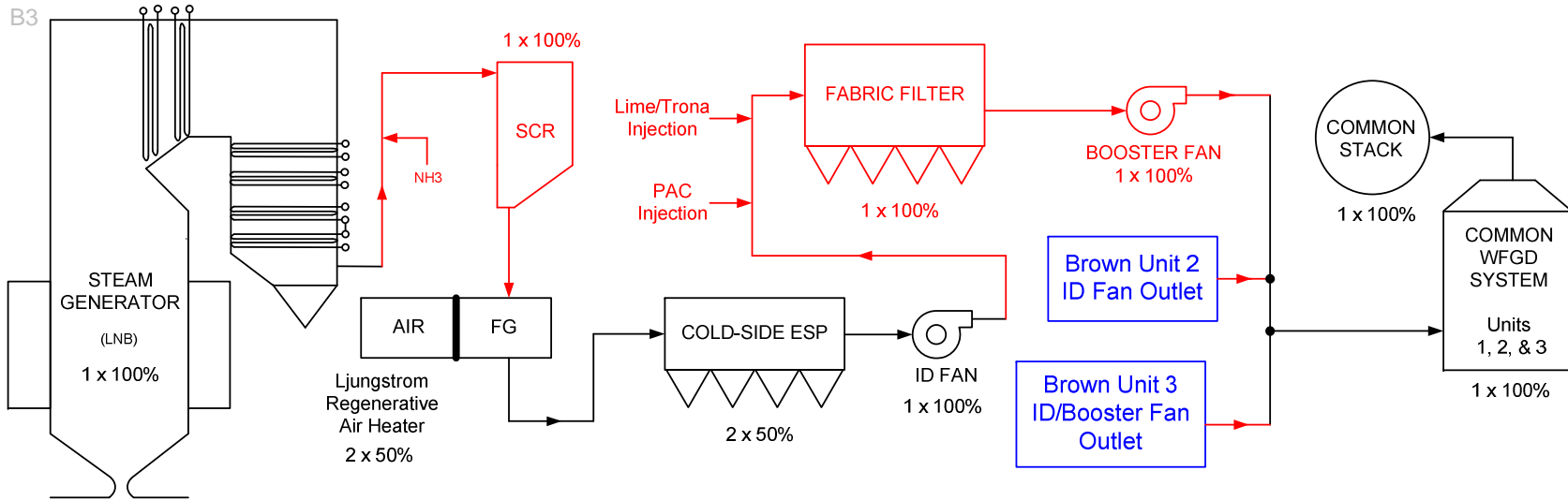

**Brown Unit 1: Future**  
**Unit 1: 110 MW Option 2**

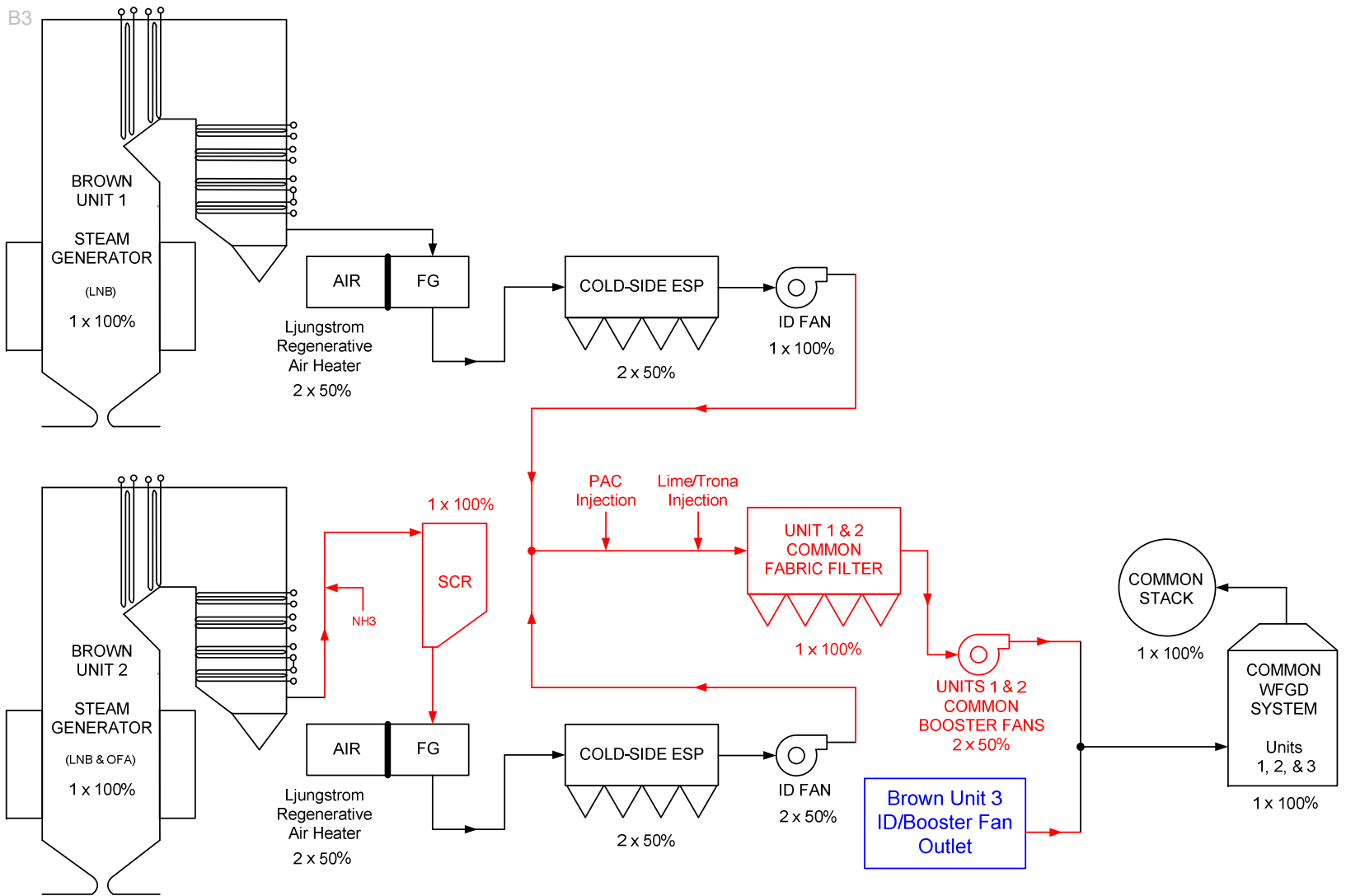

**Brown Unit 1 & 2: Future**

- Unit 1: 110 MW Option 3**
- Unit 2: 180 MW Option 2**



**Ghent**

B3

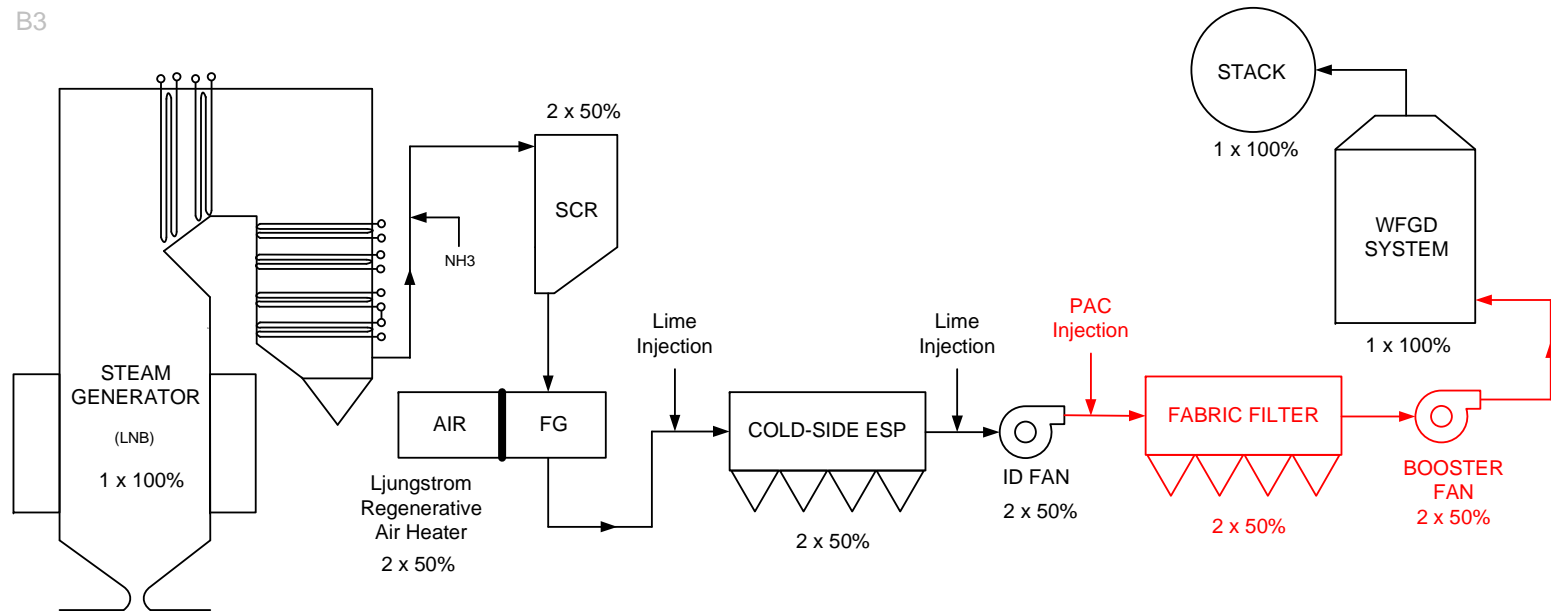

**Ghent Unit 1: Future**

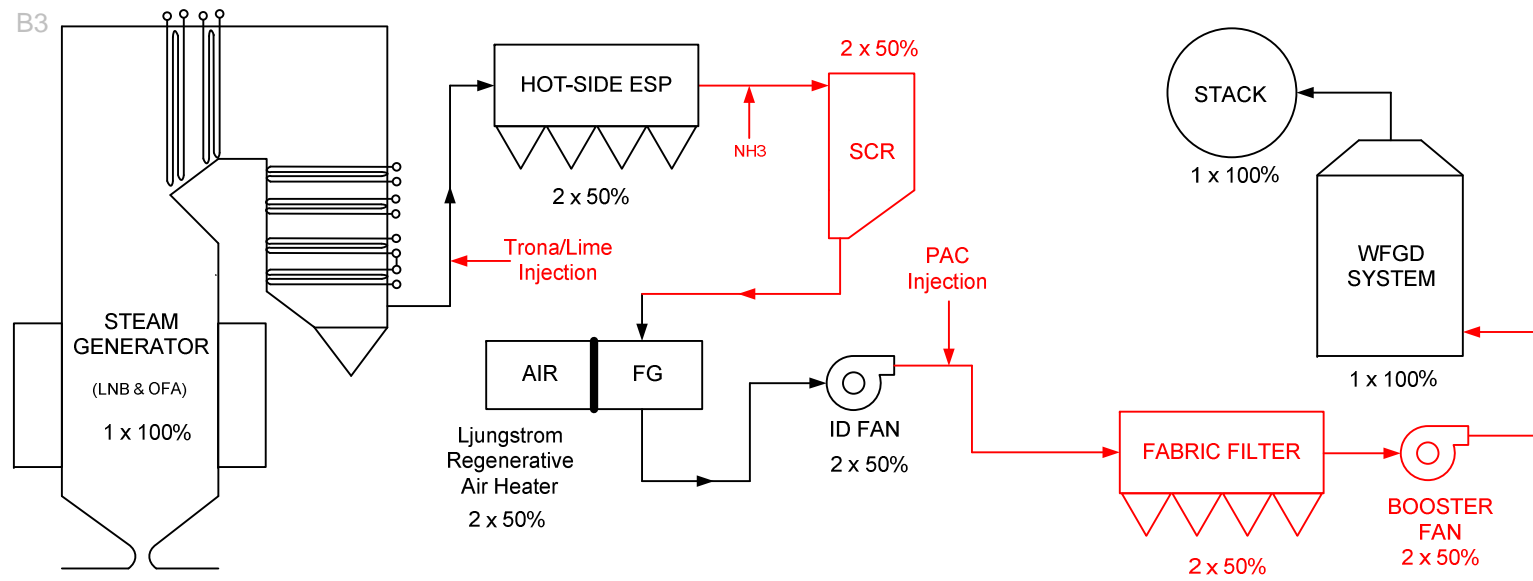

**Ghent Unit 2: Future**

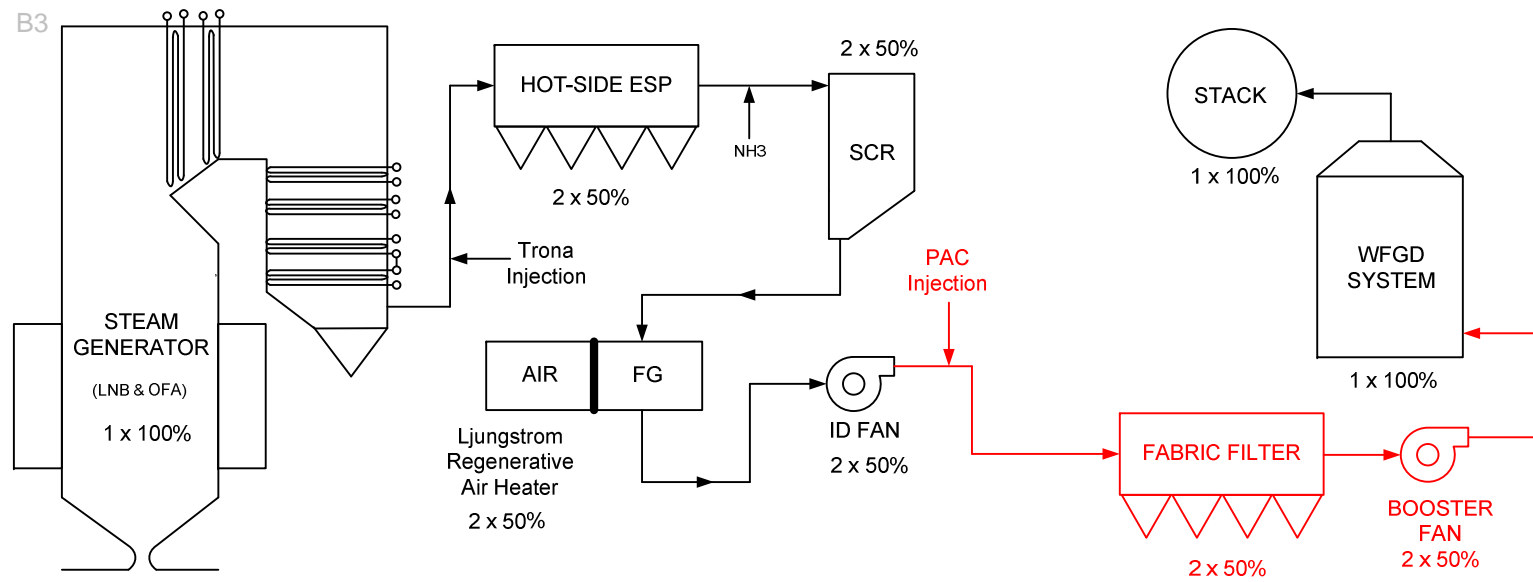

**Ghent Unit 3/4: Future**

# **Cane Run**

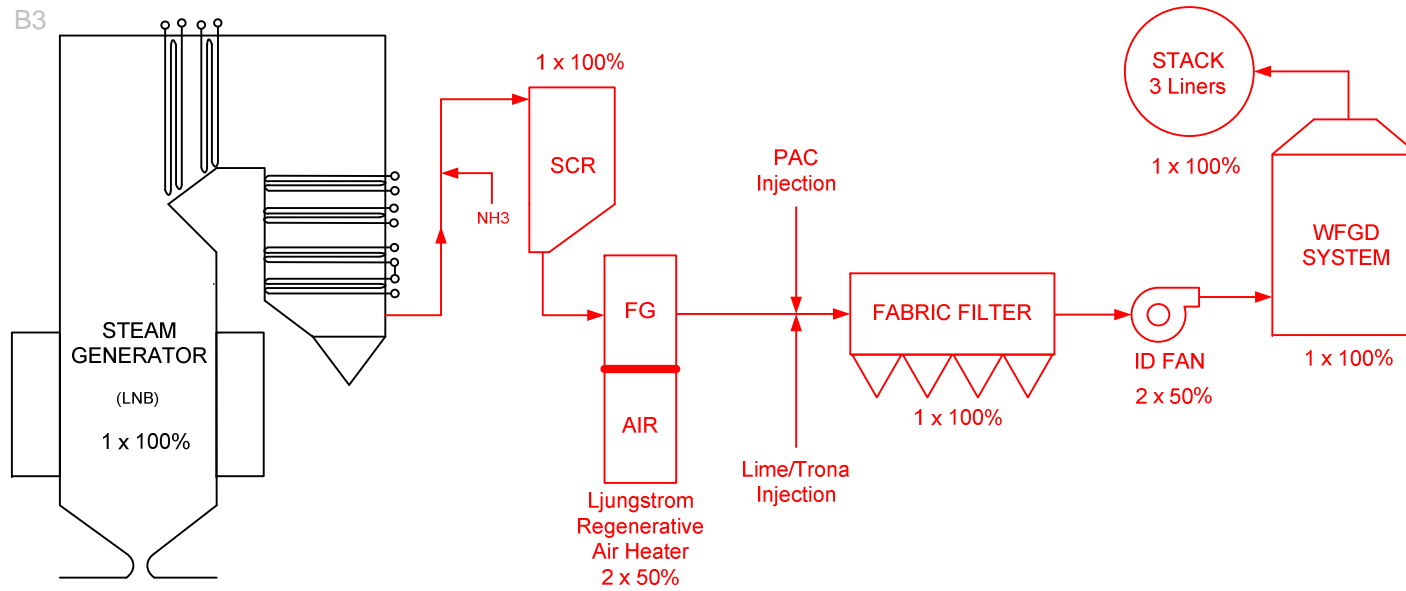

**Cane Run Unit 4: Future  
168 MW**

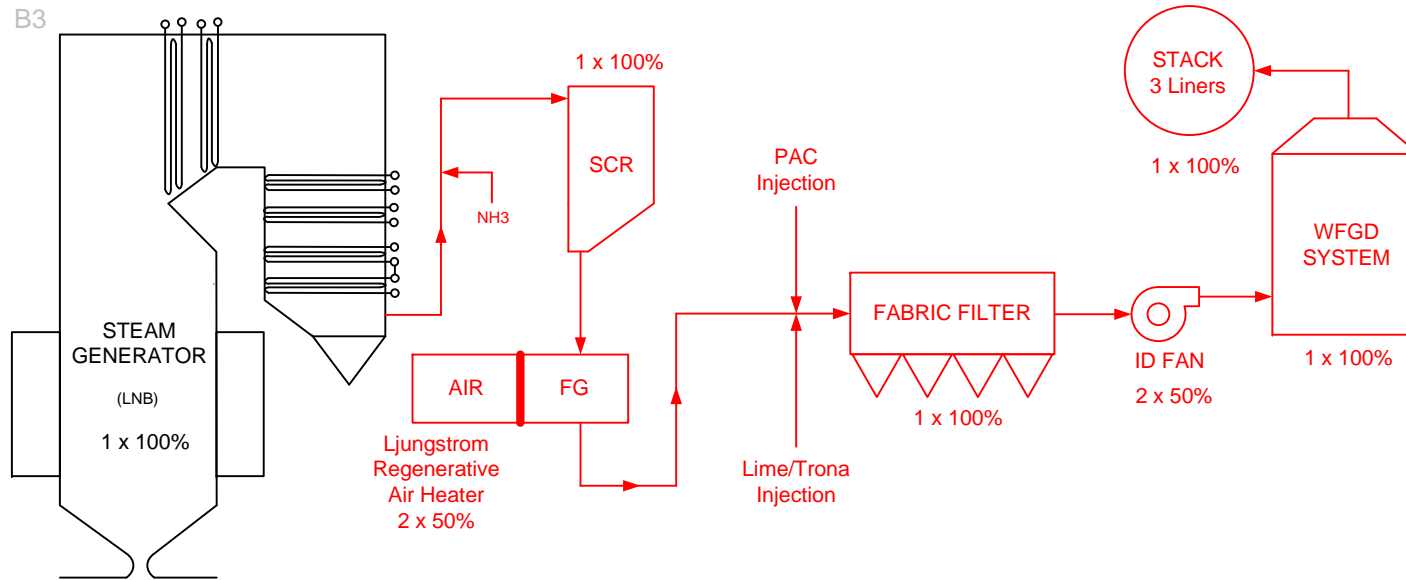

**Cane Run Unit 5: Future  
181 MW**

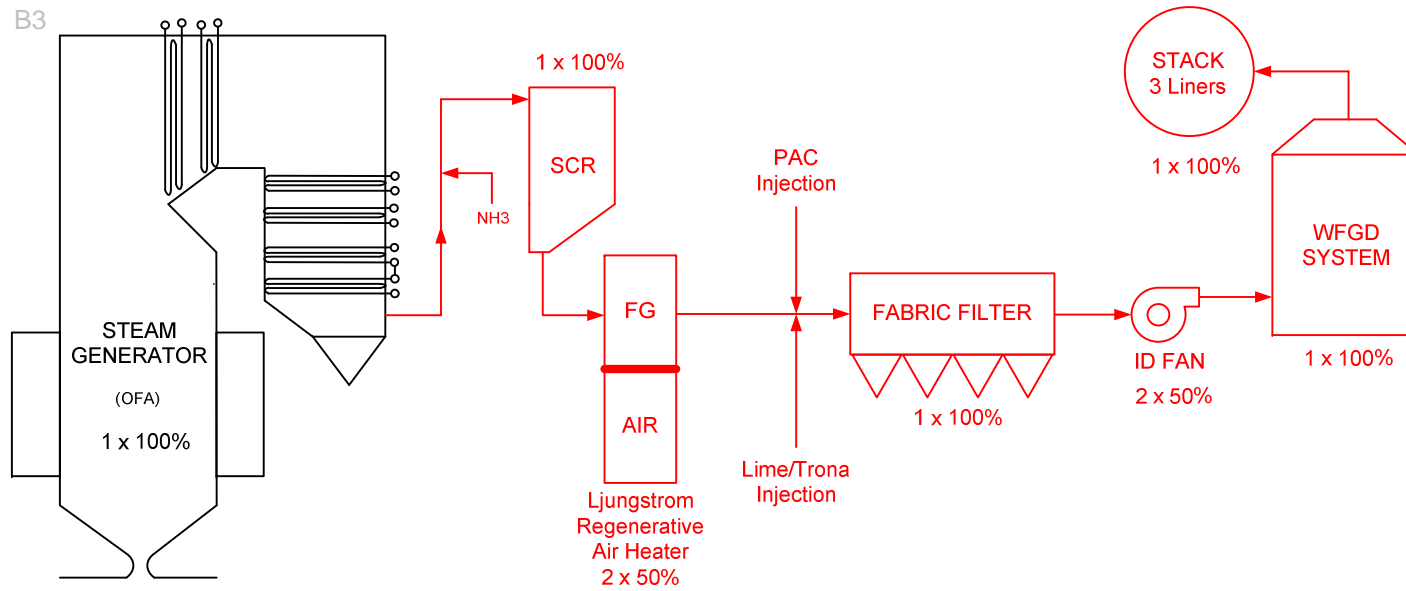

**Cane Run Unit 6: Future  
261 MW**



# **Mill Creek**

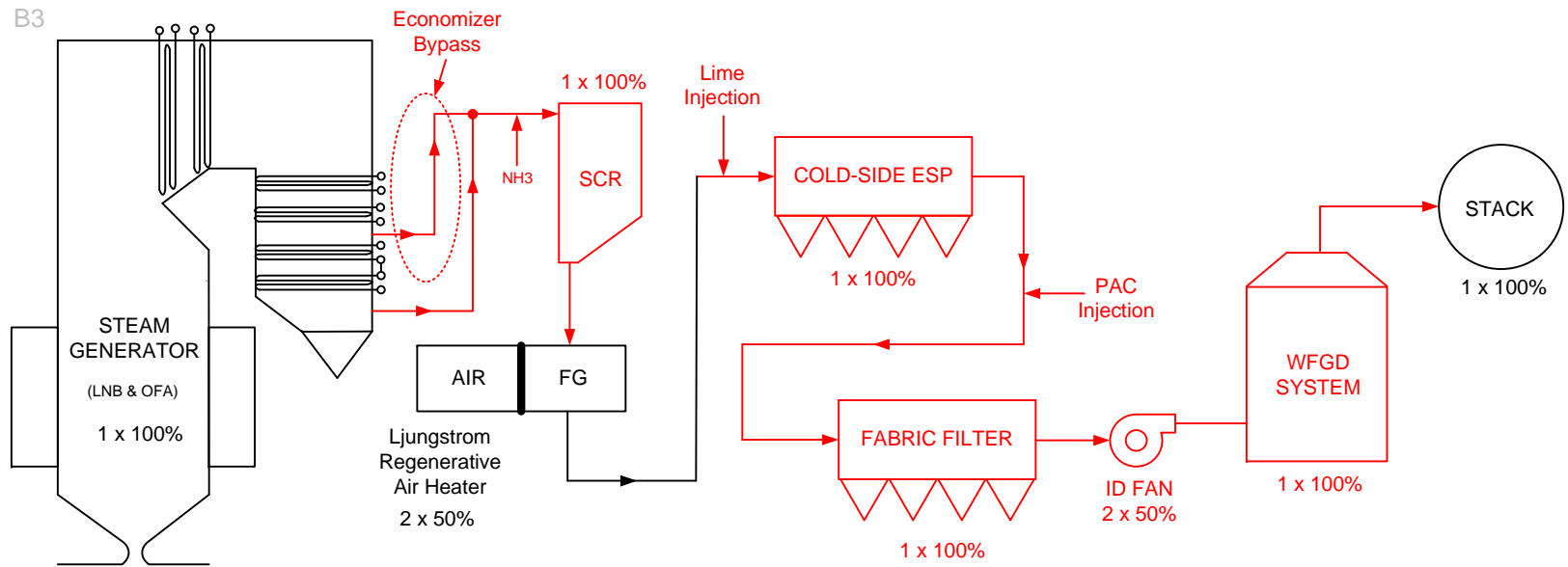

**Mill Creek Unit 1/2: Future**

**Unit 1: 330 MW**

**Unit 2: 330 MW**

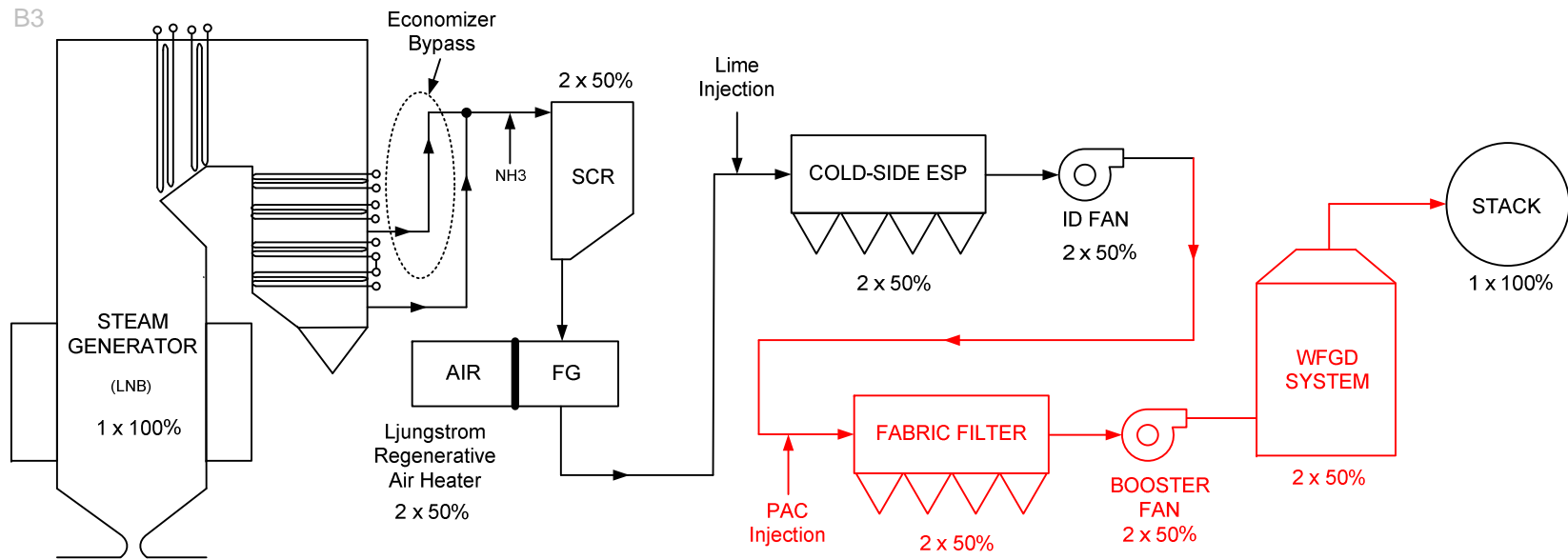

**Mill Creek Unit 3/4: Future**

**Unit 3: 423 MW**

**Unit 4: 525 MW**

**Mill Creek  
AQC Technology Options**

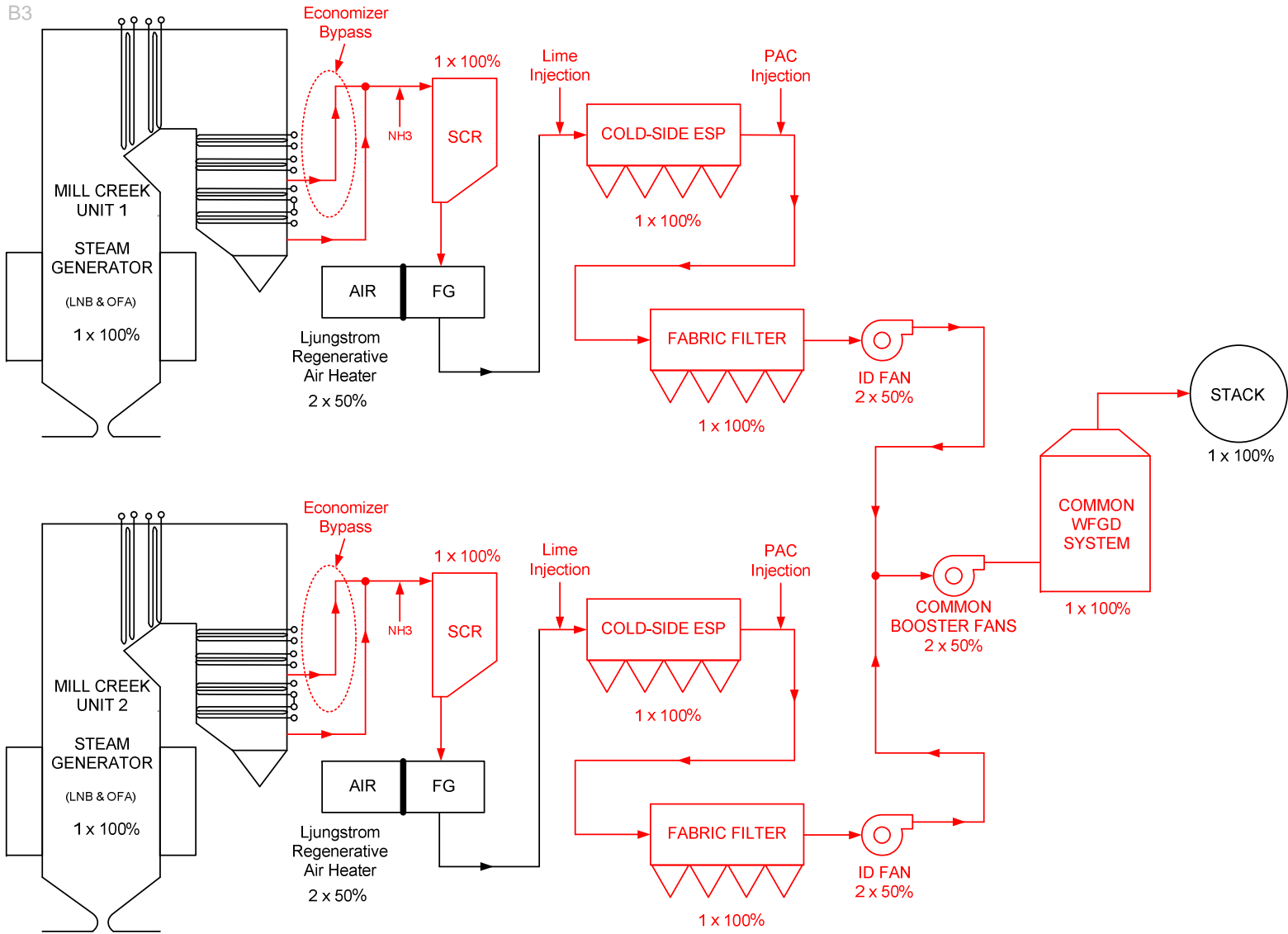

**Mill Creek Unit 1/2: Future**

**Unit 1: 330 MW Option 2**  
**Unit 2: 330 MW Option 2**

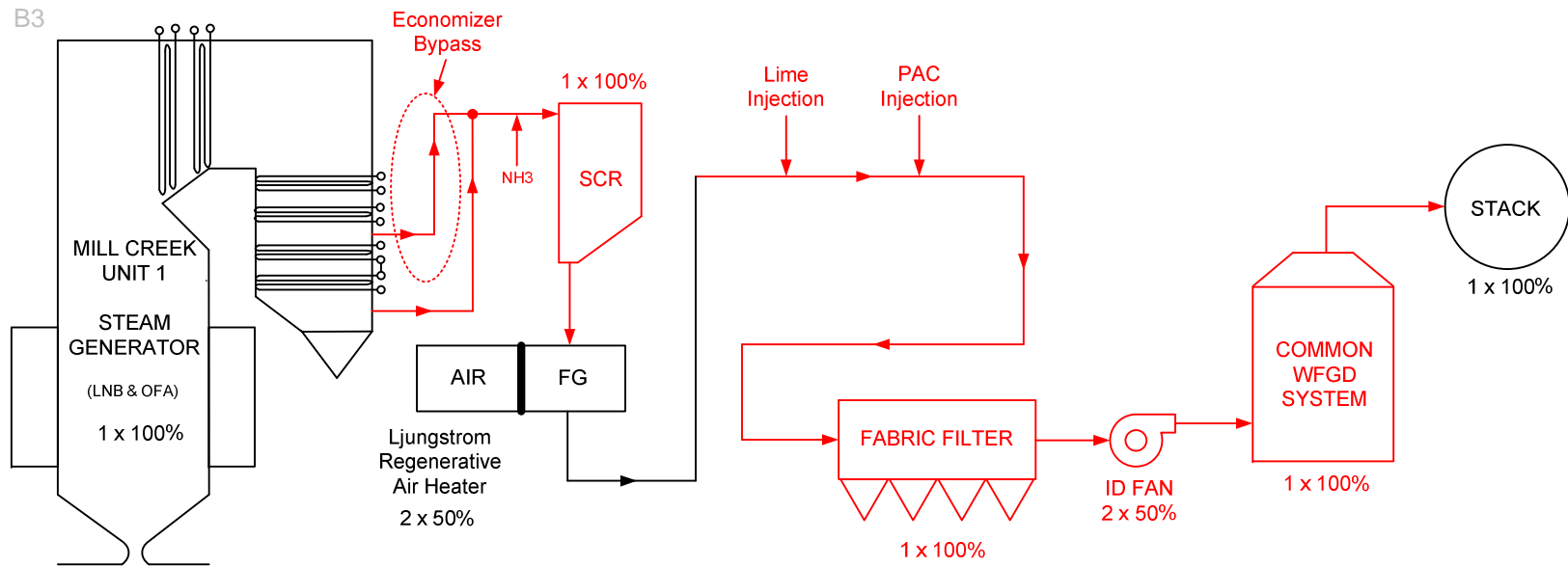

**Mill Creek Unit 1/2: Future**  
**Unit 1: 330 MW Option 3**  
**Unit 2: 330 MW Option 3**

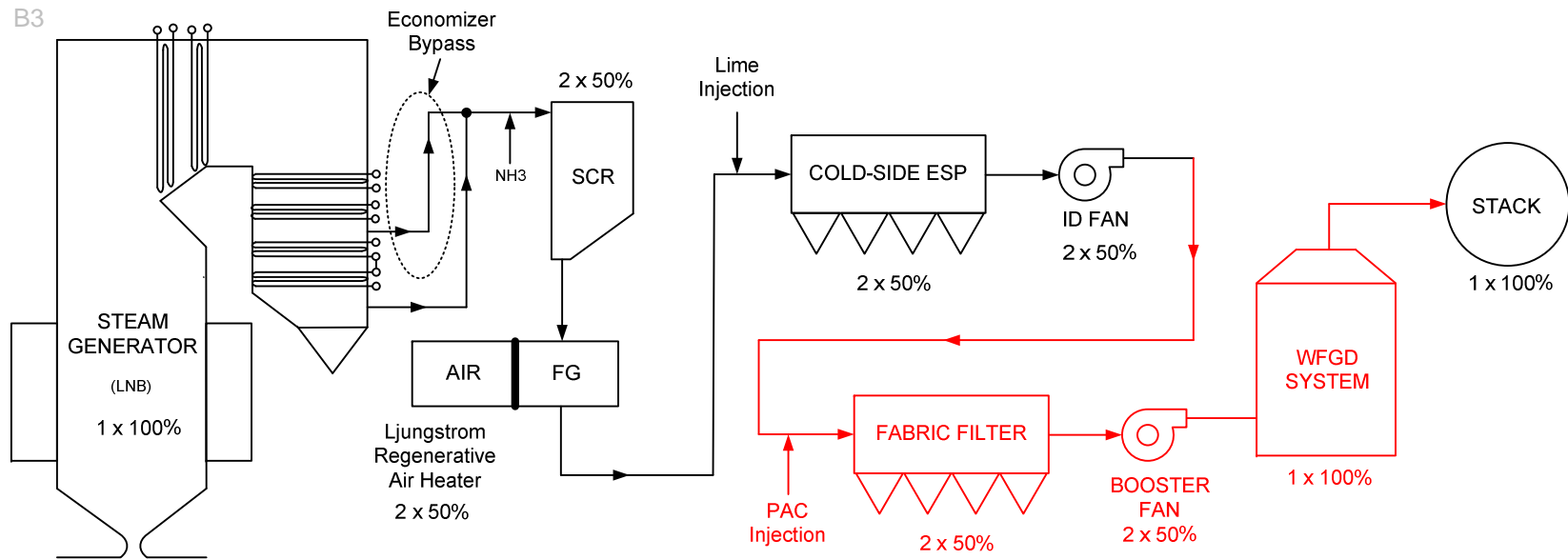

**Mill Creek Unit 3/4: Future**  
**Unit 3: 423 MW Option 2**  
**Unit 4: 525 MW Option 2**

# **Trimble County**



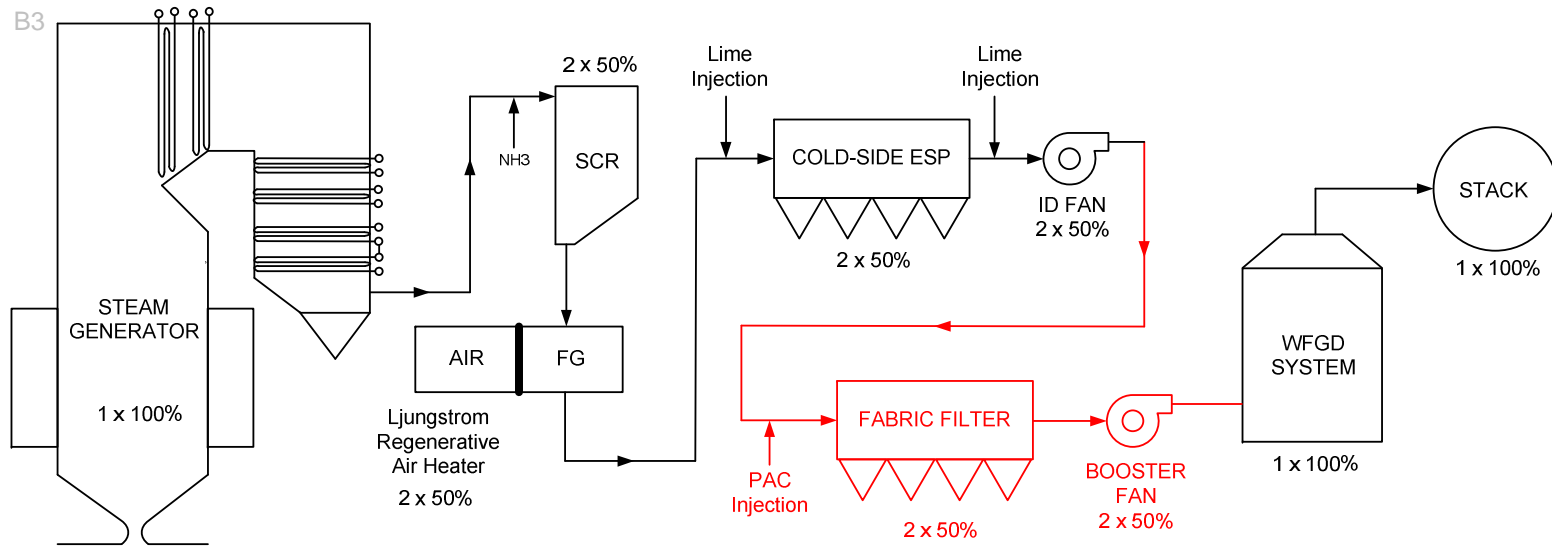

**Trimble County Unit 1: Future**

# **Green River**

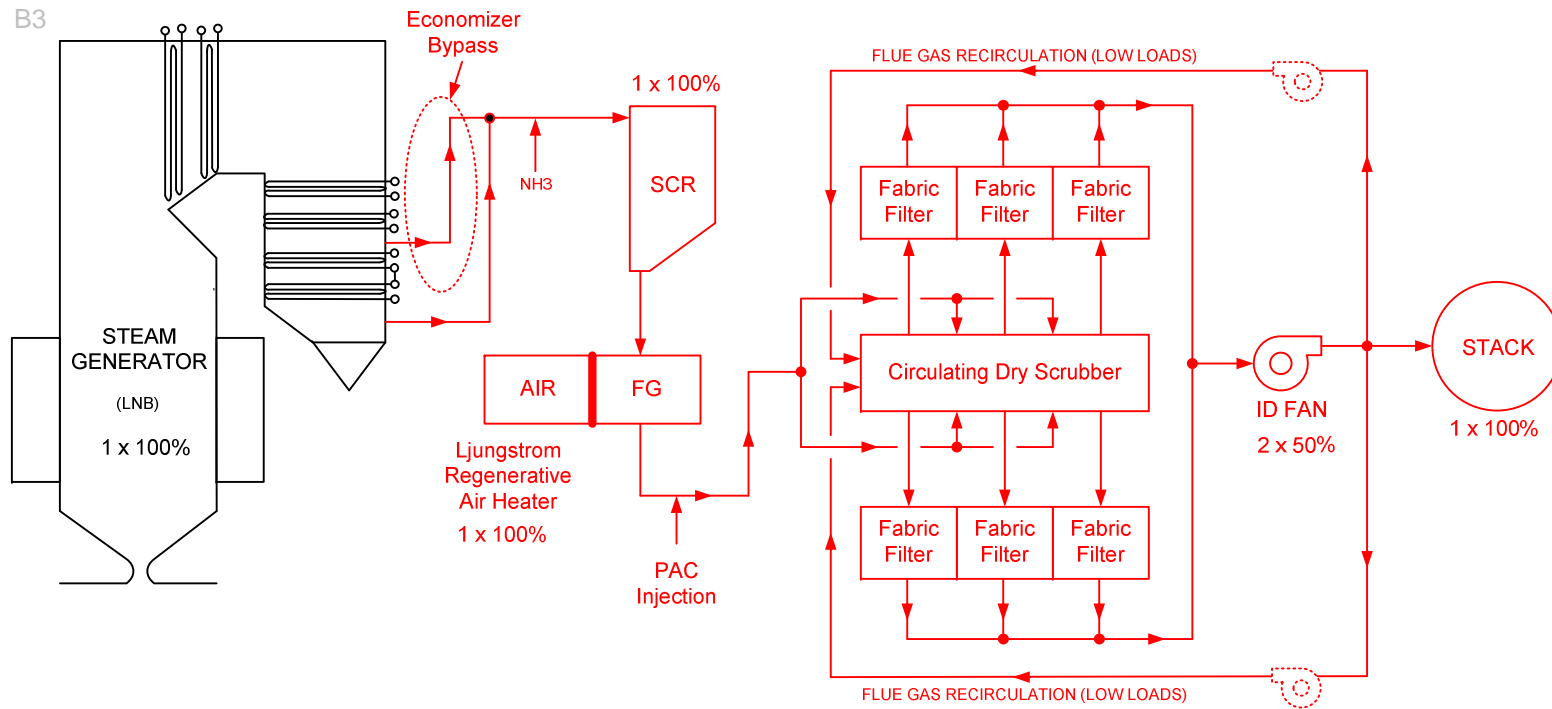

**Green River Unit 3: Future  
71 MW**

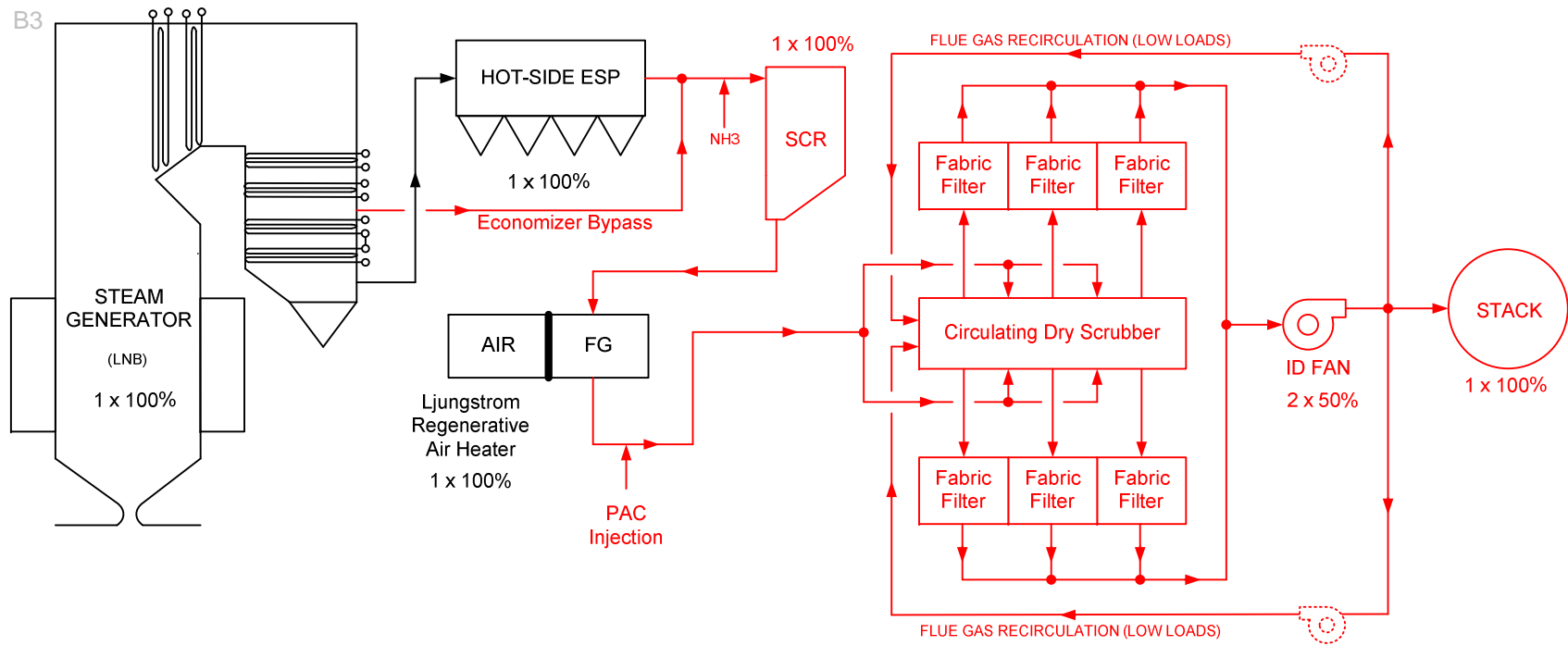

**Green River Unit 4: Future  
109 MW**