

EAST KENTUCKY NETWORK

d/b/a

APPALACHIAN WIRELESS

**BLACKEY
CELLULAR TOWER
APPLICATION**

Letcher County, Kentucky
P.S.C. CASE # 2008-00089

RECEIVED

MAR 26 2008

PUBLIC SERVICE
COMMISSION

1	Notification/Response from County.
2	Copies of Cell Site Notices.
3	Universal Letter of Soil Bearing Analysis.
4	Kentucky Airport Zoning Commission Application.
5	Tower Design.
6	FAA Approval/Notice of Proposed Construction.
7	Audited Financial Statements
8	Driving Directions and Map to Suitable Scale.
9	Deed/Lease Agreement for Proposed Site.
10	Survey of Site Signed/Sealed by Professional Engineer Registered in State of Kentucky.
11	Site Survey Map with Property Owners identified in Accordance with PVA of County.
12	Vertical Profile Sketch of Proposed Tower.

COMMONWEALTH OF KENTUCKY
BEFORE THE PUBLIC SERVICE COMMISSION

RECEIVED

MAR 26 2008

PUBLIC SERVICE
COMMISSION

In the matter of:

THE APPLICATION OF EAST KENTUCKY NETWORK)
LIMITED LIABILITY COMPANY FOR THE ISSUANCE)
OF A CERTIFICATE OF PUBLIC CONVENIENCE AND) CASE No 2008-00089
NECESSITY TO CONSTRUCT A TOWER IN LETCHER)
COUNTY, KENTUCKY).

In case number 91-002 East Kentucky Network, LLC, formerly Mountaineer Cellular Limited Liability Company was granted a Certificate of Public Convenience and Necessity by the Kentucky Public Service Commission to construct and operate a cellular radio telecommunications system for KY RSA 10.

In an effort to improve service in Letcher County, East Kentucky Network, LLC pursuant to KRS 278.020 Subsection 1 and 807 KAR 5:001 Section 9 is seeking the Commission's approval to construct a tower near Blackey. The proposed tower will be a 300 foot self-supporting tower located on a ridge between Orchard Branch and Bull Creek, approximately one and three quarter miles northwest of Blackey in Letcher County, Kentucky (37° 9' 20.7" N, 83° 0' 7.5"W). A map and detailed directions to the site can be found in Exhibit 8.

East Kentucky Network LLC merger documents were filed with the Commission on February 2, 2001 in Case # 2001-022.

FAA and Kentucky Airport Zoning Commission approvals have been applied for and a copy of the application is included as Exhibit 4 and 6.

No Federal Communications Commission approval is required prior to construction of this facility. Once service is established from this tower we must immediately notify the Federal Communications Commission of its operation. Prior approval is needed only if the proposed

facility increases the size of the cellular geographic service area. This cell site will not expand the cellular geographic service area.

A geologist was employed to determine soil and rock types and to ascertain the distance to solid bedrock. The geotechnical report is enclosed as Exhibit 3

A copy of the tower design information is enclosed as Exhibit 5. The proposed tower has been designed by engineers at Allstate Tower, Inc and will be constructed under their supervision. Their qualifications are evidenced in Exhibit 5 by the seal and signature of the registered professional engineer responsible for this project.

The tower will be erected by A & D Communication of Cattlesburg, Kentucky. A & D has vast experience in the erection of communications towers.

Enclosed, and should be filed with Exhibit 10 is a survey of the proposed tower site signed by a Kentucky registered professional engineer. There is no structure within 500 feet of the proposed tower as indicated in this enclosure. Exhibit 2 is a list of all Property owners or residents according to the property valuation administrator's record who reside or own property within 500 feet of the proposed tower in accordance with the Public Valuation Administrator'. No other properties are contiguous with East Kentucky's property.

Exhibit 12, back of folder, contains a vertical sketch of the tower supplied by Coleman Engineering.

Pursuant to 807 KAR5:063 Sections 1(1)(L) and Section 1(1)(n)(1) all affected property owners according to the property valuation administrator's record who reside or own property within 500 feet of the proposed Tower were notified by certified mail return receipt requested of East Kentucky Network, LLC's proposed construction and informed of their right to intervene. They were given the docket number under which this application is filed. Enclosed in Exhibit 2 is a copy of that notification.

Letcher County has no formal local planning unit. In absence of this unit the Letcher County Judge Executive's office was notified by certified mail, return receipt requested of East Kentucky Network Limited Liability Company's proposal and informed of their right to intervene. They were given the docket number under which this application is filed. Enclosed in Exhibit 1 is a copy of that notification.

East Kentucky Network, LLC will finance the subject Construction with earned surplus in its General Fund.

Estimated Cost of Construction	140,000.00
Annual Operation Expense of Tower	12,500.00

Two notice signs meeting the requirements prescribed by 807 KAR 5:063, Section 1(2), measuring at least two (2) feet in height and four (4) feet in width and containing all required language in letters of required height, have been posted, one at a visible location on the proposed site and one on the nearest public road. The two signs were posted on March 14, 2008 and will remain posted for at least two weeks after filing of this application as specified.

Enclosed in Exhibit 9 is a copy of East Kentucky Network LLC's deeds to the site.

Notice of the location of the proposed construction was published on the first last 2 weeks of March in the Mountain Eagle. Enclosed is a copy of that notice in Exhibit 1. The Mountain Eagle is the newspaper with the largest circulation in Letcher County.

The proposed construction site is on a very rugged mountaintop some feet from the nearest structure. Prior to construction the site was wooded.

Due to the steep hillside surrounding the proposed site, the property in close proximity is unsuitable for any type of development. East Kentucky Network LLC's operation will not affect the use of nearby land nor its value. No more suitable site exists in the area. A copy of the search area map is enclosed in Exhibit 8. No other tower capable of supporting East Kentucky Network LLC's load exists in the general area; therefore, there is no opportunity for co-location of our facilities with anyone else.

WHEREFORE, Applicant respectfully requests that the PSC accept the foregoing Application for filing, and having met the requirements of KRS [278.020(1), 278.650, and 278.665] and all applicable rules and regulations of the PSC, grant a Certificate of Public Convenience and Necessity to construct and operate the proposed tower.

The foregoing document was prepared by Janice Robinson, Technical Site Coordinator for East Kentucky Network d/b/a Appalachian Wireless. All related questions or correspondence concerning this filing should be mailed to East Kentucky Network, LLC d/b/a Appalachian Wireless, 101 Technology Trail, Ivel, KY 41642.

SUBMITTED BY: Janice Robinson DATE: 03-14-08
Janice Robinson, Cell Site Coordinator

APPROVED BY: _____ DATE: _____
Gerald Robinette, General Manager

Contacts:

Gerald Robinette, General Manager

Phone: (606) 791-2375, Ext. 111
Email: grobinette110@ekn.com

Janice Robinson, Technical Site Coordinator

Phone: (606) 791-2375, Ext. 166
Email: jrobinson166a@ekn.com

Mailing Address:

East Kentucky Network, LLC.
d/b/a Appalachian Wireless
101 Technology Trail
Ivel, KY 41642

EAST KENTUCKY NETWORK
101 TECHNOLOGY TRAIL
IVEL, KY 41642
PHONE: (606) 874-7550
FAX: (606) 874-7551
INFO@EKN.COM
WWW.EKN.COM



VIA: U.S. CERTIFIED MAIL

March 14, 2008

Jim Ward, Judge/Executive
156 Main Street, Suite 107
Whitesburg, KY 41858

RE: Public Notice-Public Service Commission of Kentucky (Case No. 2008-00089)

East Kentucky Network, LLC d/b/a Appalachian Wireless has applied to the Public Service Commission of Kentucky for a Certificate of Public Convenience and Necessity to construct and operate a new facility to provide cellular telecommunications service. The facility will include a 300 foot self-supporting tower with attached antennas extending upwards, and an equipment shelter located on a ridge between Orchard Branch and Bull Creek, approximately one and three quarter miles northwest of Blackey in Letcher County, Kentucky (37° 9' 20.7" N, 83° 0' 7.5" W). A map showing the location of the proposed new facility is enclosed. This notice is being sent to you because you are the County Judge Executive of Letcher County.

The Commission invites your comments regarding the proposed construction. You also have the right to intervene in this matter. The Commission must receive your initial communication within 20 days of the date of this letter as shown above.

Your comments and request for intervention should be addressed to: Executive Director's Office, Public Service Commission of Kentucky, P.O. Box 615, Frankfort, KY 40602. Please refer to Case No. 2008-00089 in your correspondence.

Sincerely,

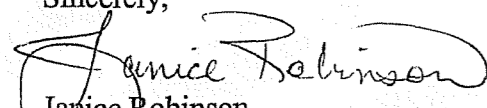
Janice Robinson
Technical Site Coordinator
enclosure

Location Map

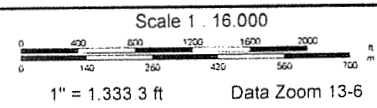
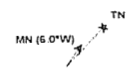
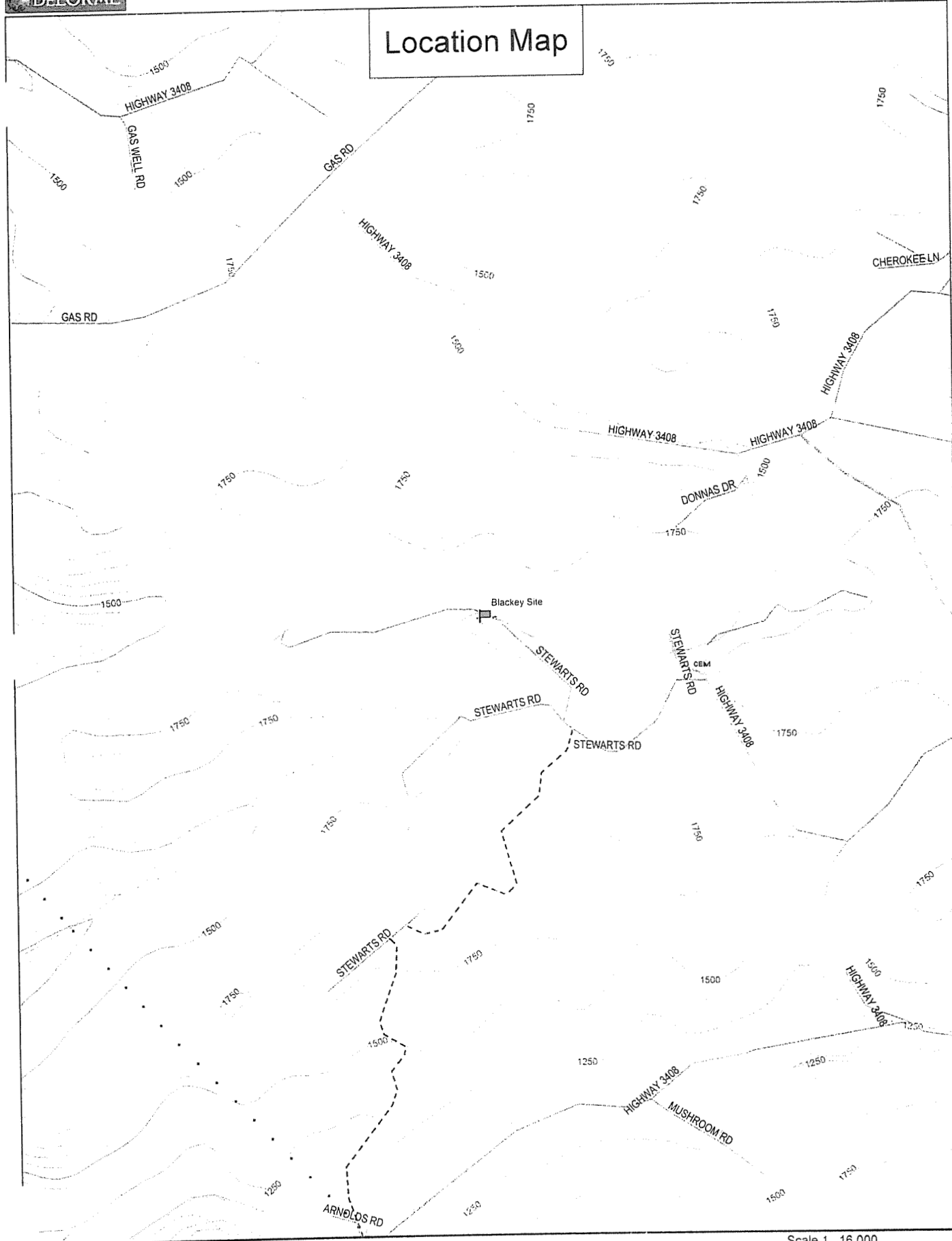

d/b/a Appalachian Wireless
P.O. Box 405
355 Village Drive
Prestonsburg, KY 41653
Phone: 606/886-6007
Fax: 606/791-2225



Fax

To: The Mountain Eagle **From:** JANICE ROBINSON

Fax: 606-633-2843 **Phone:** 606-791-2375, Ext. 166

Phone: 606-633-2252 **Pages:** Pages (INCLUDING COVER)

Re: PUBLIC NOTICE ADVERTISEMENT **Date:** March 14, 2008

Nancy,

We would like to have the following public notice printed in The Mountain Eagle for the next two weeks. The notice should state the following:

PUBLIC NOTICE:

RE: Public Service Commission of Kentucky (CASE NO. 2008-00089)

Notice is hereby given that East Kentucky Network, LLC, dba Appalachian Wireless has applied to the Kentucky Public Service Commission to construct a tower near Blackey, in Letcher County. The proposed tower will be a 300-foot self-supporting tower. The proposed tower site is situated on a ridge between Orchard Branch and Bull Creek, approximately one and three quarter miles northwest of Blackey in Letcher County, Kentucky (37° 9' 20.7" N, 83° 0' 7.5"W).

If you would like to respond to this notice, please contact the Executive Director, Public Service Commission, 211 Sower Boulevard, P O Box 615, Frankfort, Kentucky 40602. Please refer to Case No. 2008-00089

If you have questions about the placement of the above mentioned notice, please call me at 606-791-2375, ext. 166.

Thank you,

Janice Robinson

Accounting Department If you have any problems with this fax, please call 606/886-6007.

The message above and the information contained in the documents transmitted are confidential and intended only for the person(s) named above. Dissemination, distribution or copying of this communication by anyone other than the person(s) named above is prohibited. If you have received this communication in error, please notify us immediately by telephone and return the original message to us at the address listed above via regular mail. Thank you.

* * * Communication Result Report (Mar. 14. 2008 11:24AM) * * *

1) Ekn
2)

e/Time: Mar. 14. 2008 11:23AM

File No.	Mode	Destination	Pg (s)	Result	Page Not Sent
0656	Memory TX	6332843	P. 1	OK	

Reason for error

E. 1) Hang up or line fail	E. 2) Busy
E. 3) No answer	E. 4) No facsimile connection
E. 5) Exceeded max. E-mail size	

dba Appalachian Wireless
P.O. Box 405
355 Village Drive
Frestonsburg, KY 41053
Phone: 606/886-6007
Fax: 606/781-2225



Fax

To: The Mountain Eagle From: JANICE ROBINSON

Fax: 606-833-2843 Phone: 606-791-2375, Ext. 166

Phone: 606-833-2252 Pages: 1 Pages (INCLUDING COVER)

Re: PUBLIC NOTICE ADVERTISEMENT Date: March 14, 2008

Nancy,
We would like to have the following public notice printed in The Mountain Eagle for the next two weeks. The notice should state the following:

PUBLIC NOTICE:
RE: Public Service Commission of Kentucky (CASE NO. 2008-00089)
Notice is hereby given that East Kentucky Network, LLC, dba Appalachian Wireless has applied to the Kentucky Public Service Commission to construct a tower near Blackey, in Letcher County. The proposed tower will be a 300-foot self-supporting tower. The proposed tower site is situated on a ridge between Orchard Branch and Bull Creek, approximately one and three quarter miles northwest of Blackey in Letcher County, Kentucky (37° 9' 20.7" N, 88° 6' 7.5" W).
If you would like to respond to this notice, please contact the Executive Director, Public Service Commission, 211 Sower Boulevard, P O Box 615, Frankfort, Kentucky 40602. Please refer to Case No. 2008-00089

If you have questions about the placement of the above mentioned notice, please call me at 606-791-2375, ext. 166.

Thank you,
Janice Robinson

Accounting Department If you have any problems with this fax, please call 606/886-6007.

The message above and the information contained in the documents transmitted are confidential and intended only for the person(s) named above. Dissemination, distribution or copying of this communication by anyone other than the person(s) named above is prohibited. If you have received this communication in error, please notify us immediately by telephone and return the original message to us at the address listed above via regular mail. Thank you.

EXHIBIT II : LIST OF PROPERTY OWNERS:

BLACKKEY TOWER SITE, LETCHER COUNTY, KENTUCKY

Statement Pursuant to Section 1 (1) (I) 807 KAR 5:063

Section 1 (1)(I) 1. The following is a list of every property owner who according to property valuation administrator's records, owns property within 500 feet of the proposed tower and each have been: notified by certified mail, return receipt requested, of the proposed construction.,

Section 1 (1) I 2.: Every person listed below who, according to the property valuation administrator's records, owns property within 500 feet of the proposed tower has been: Given the Commission docket number under which the application will be processed: and

Section 1 (1) I 3. Every person listed below who, according to property valuation administrator's records, owns property within 500 feet of the proposed tower has been: Informed of his right to request intervention.

LIST OF PROPERTY OWNERS

Charles & Joyce Whitaker
14 Stewarts Rd
Blackey, KY 41804

Suzanne Whitakre Madden
562 Hill Top Farm Rd
Blackey, KY 41804

Francis & Stewart Whitaker
1050 Stewarts Rd
Blackey, KY 41804

Ethel Polly
Box 394
Elkhorn City, KY 41522

Elkhorn Hazard Coal Land
Box 929
Whitesburg, KY 41858

James Robert Fields
681 Pridemore Hollow Rd
Hendersonville, NC 28739

Sandra Cowden
882 Sterwarts Rd
Blackey, KY 41804

Wilma J & Hohn E Cordder
7082 N 650w
Fariland, IN. 46126

Tina, Amber & Anthony Barrett
C/O Brenda Halcomb
2449 HWY 3408
Blackey, KY 41804

Sam & Kansas Mullins
C/O Roy Mullins
Box 542
Isom, KY 41824

Black Marlin Estate
C/O Doris Wayne & Deborah Back
854 HWY 3408
Blackey, KY 41804

EAST KENTUCKY NETWORK
101 TECHNOLOGY TRAIL
IVEL, KY 41642
PHONE: (606) 874-7550
FAX: (606) 874-7551
INFO@EKN.COM
SITE: WWW.EKN.COM



VIA: U.S. CERTIFIED MAIL

PUBLIC NOTICE

March 14, 2008

Black Marlin Estate
C/O Doris Wayne & Deborah Back
854 HWY 3408
Blackey, KY 41804

RE: Public Notice-Public Service Commission of Kentucky (Case No. 2008-00089)

East Kentucky Network, LLC d/b/a Appalachian Wireless has applied to the Public Service Commission of Kentucky for a Certificate of Public Convenience and Necessity to construct and operate a new facility to provide cellular telecommunications service. The facility will include a 300 foot self supporting tower with attached antennas extending upwards, and an equipment shelter located approximately one and three quarter miles northwest of Blackey in Letcher County, Kentucky (37° 9' 20.7" N, 83° 0' 7.5"W). A map showing the location of the proposed new facility is enclosed. This notice is being sent to you because you may own property or reside within a 500' radius of the proposed tower.

The Commission invites your comments regarding the proposed construction. You also have the right to intervene in this matter. The Commission must receive your initial communication within 20 days of the date of this letter as shown above.

Your comments and request for intervention should be addressed to: Executive Director's Office, Public Service Commission of Kentucky, P.O. Box 615, Frankfort, KY 40602. Please refer to Case No. 2008-00089 in your correspondence.

Sincerely,

A handwritten signature in cursive script that reads "Janice Robinson".

Janice Robinson
Technical Site Coordinator
Enclosure 1

EAST KENTUCKY NETWORK
101 TECHNOLOGY TRAIL
IVEL, KY 41642
PHONE: (606) 874-7550
FAX: (606) 874-7551
EMAIL: INFO@EKN.COM
WEBSITE: WWW.EKN.COM



VIA: U.S. CERTIFIED MAIL

PUBLIC NOTICE

March 14, 2008

Sam & Kansas Mullins
C/O Roy Mullins
Box 542
Isom, KY 41824

RE: Public Notice-Public Service Commission of Kentucky (Case No. 2008-00089)

East Kentucky Network, LLC d/b/a Appalachian Wireless has applied to the Public Service Commission of Kentucky for a Certificate of Public Convenience and Necessity to construct and operate a new facility to provide cellular telecommunications service. The facility will include a 300 foot self supporting tower with attached antennas extending upwards, and an equipment shelter located approximately one and three quarter miles northwest of Blackey in Letcher County, Kentucky (37° 9' 20.7" N, 83° 0' 7.5"W). A map showing the location of the proposed new facility is enclosed. This notice is being sent to you because you may own property or reside within a 500' radius of the proposed tower.

The Commission invites your comments regarding the proposed construction. You also have the right to intervene in this matter. The Commission must receive your initial communication within 20 days of the date of this letter as shown above.

Your comments and request for intervention should be addressed to: Executive Director's Office, Public Service Commission of Kentucky, P.O. Box 615, Frankfort, KY 40602. Please refer to Case No. 2008-00089 in your correspondence.

Sincerely,

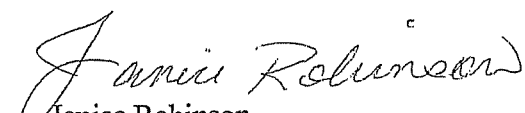
Janice Robinson
Technical Site Coordinator

EAST KENTUCKY NETWORK
101 TECHNOLOGY TRAIL
IVEL, KY 41642
PHONE: (606) 874-7550
FAX: (606) 874-7551
EMAIL: INFO@EKN.COM
WEBSITE: WWW.EKN.COM



VIA: U.S. CERTIFIED MAIL

PUBLIC NOTICE

March 14, 2008

Tina, Amber & Anthony Barrett
c/O Brenda Halcomb
2449 HWY 3408
Blackey KY 41804

RE: Public Notice-Public Service Commission of Kentucky (Case No. 2008-00089)

East Kentucky Network, LLC d/b/a Appalachian Wireless has applied to the Public Service Commission of Kentucky for a Certificate of Public Convenience and Necessity to construct and operate a new facility to provide cellular telecommunications service. The facility will include a 300 foot self supporting tower with attached antennas extending upwards, and an equipment shelter located approximately one and three quarter miles northwest of Blackey in Letcher County, Kentucky (37° 9' 20.7" N, 83° 0' 7.5"W). A map showing the location of the proposed new facility is enclosed. This notice is being sent to you because you may own property or reside within a 500' radius of the proposed tower.

The Commission invites your comments regarding the proposed construction. You also have the right to intervene in this matter. The Commission must receive your initial communication within 20 days of the date of this letter as shown above.

Your comments and request for intervention should be addressed to: Executive Director's Office, Public Service Commission of Kentucky, P.O. Box 615, Frankfort, KY 40602. Please refer to Case No. 2008-00089 in your correspondence.

Sincerely,

Janice Robinson
Technical Site Coordinator

EAST KENTUCKY NETWORK
101 TECHNOLOGY TRAIL
IVEL, KY 41642
PHONE: (606) 874-7550
FAX: (606) 874-7551
INFO@EKN.COM
WWW.EKN.COM



VIA: U.S. CERTIFIED MAIL

PUBLIC NOTICE

March 14, 2008

Wilma J & Hohn E. Corder
7082 N 650w
Fairiland, IN 46126

RE: Public Notice-Public Service Commission of Kentucky (Case No. 2008-00089)

East Kentucky Network, LLC d/b/a Appalachian Wireless has applied to the Public Service Commission of Kentucky for a Certificate of Public Convenience and Necessity to construct and operate a new facility to provide cellular telecommunications service. The facility will include a 300 foot self supporting tower with attached antennas extending upwards, and an equipment shelter located approximately one and three quarter miles northwest of Blackey in Letcher County, Kentucky (37° 9' 20.7" N, 83° 0' 7.5"W). A map showing the location of the proposed new facility is enclosed. This notice is being sent to you because you may own property or reside within a 500' radius of the proposed tower.

The Commission invites your comments regarding the proposed construction. You also have the right to intervene in this matter. The Commission must receive your initial communication within 20 days of the date of this letter as shown above.

Your comments and request for intervention should be addressed to: Executive Director's Office, Public Service Commission of Kentucky, P.O. Box 615, Frankfort, KY 40602. Please refer to Case No. 2008-00089 in your correspondence.

Sincerely,

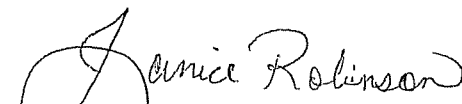
Janice Robinson
Technical Site Coordinator
Enclosure 1

EAST KENTUCKY NETWORK
101 TECHNOLOGY TRAIL
IVEL, KY 41642
PHONE: (606) 874-7550
FAX: (606) 874-7551
INFO@EKN.COM
TE: WWW.EKN.COM



VIA: U.S. CERTIFIED MAIL

PUBLIC NOTICE

March 14, 2008

Sandra Cowden
882 Sterwarts Rd
Blackey, KY 41804

RE: Public Notice-Public Service Commission of Kentucky (Case No. 2008-00089)

East Kentucky Network, LLC d/b/a Appalachian Wireless has applied to the Public Service Commission of Kentucky for a Certificate of Public Convenience and Necessity to construct and operate a new facility to provide cellular telecommunications service. The facility will include a 300 foot self supporting tower with attached antennas extending upwards, and an equipment shelter located approximately one and three quarter miles northwest of Blackey in Letcher County, Kentucky (37° 9' 20.7" N, 83° 0' 7.5"W). A map showing the location of the proposed new facility is enclosed. This notice is being sent to you because you may own property or reside within a 500' radius of the proposed tower.

The Commission invites your comments regarding the proposed construction. You also have the right to intervene in this matter. The Commission must receive your initial communication within 20 days of the date of this letter as shown above.

Your comments and request for intervention should be addressed to: Executive Director's Office, Public Service Commission of Kentucky, P.O. Box 615, Frankfort, KY 40602. Please refer to Case No. 2008-00089 in your correspondence.

Sincerely,

A handwritten signature in cursive script that reads "Janice Robinson".

Janice Robinson
Technical Site Coordinator
Enclosure 1

EAST KENTUCKY NETWORK
101 TECHNOLOGY TRAIL
IVEL, KY 41642
PHONE: (606) 874-7550
'06) 874-7551
INFO@EKN.COM
WEBSITE: WWW.EKN.COM



VIA: U.S. CERTIFIED MAIL

PUBLIC NOTICE

March 14, 2008

James Robert Fields
681 Pridemore Hollow Rd
Hendersonville, NC 28739

RE: Public Notice-Public Service Commission of Kentucky (Case No. 2008-00089)

East Kentucky Network, LLC d/b/a Appalachian Wireless has applied to the Public Service Commission of Kentucky for a Certificate of Public Convenience and Necessity to construct and operate a new facility to provide cellular telecommunications service. The facility will include a 300 foot self supporting tower with attached antennas extending upwards, and an equipment shelter located approximately one and three quarter miles northwest of Blackey in Letcher County, Kentucky (37° 9' 20.7" N, 83° 0' 7.5" W). A map showing the location of the proposed new facility is enclosed. This notice is being sent to you because you may own property or reside within a 500' radius of the proposed tower.

The Commission invites your comments regarding the proposed construction. You also have the right to intervene in this matter. The Commission must receive your initial communication within 20 days of the date of this letter as shown above.

Your comments and request for intervention should be addressed to: Executive Director's Office, Public Service Commission of Kentucky, P.O. Box 615, Frankfort, KY 40602. Please refer to Case No. 2008-00089 in your correspondence.

Sincerely,

A handwritten signature in cursive script that reads "Janice Robinson".

Janice Robinson
Technical Site Coordinator
Enclosure 1

EAST KENTUCKY NETWORK
101 TECHNOLOGY TRAIL
IVEL, KY 41642
PHONE: (606) 874-7550
FAX: (606) 874-7551
INFO@EKN.COM
WEBSITE: WWW.EKN.COM



VIA: U.S. CERTIFIED MAIL

PUBLIC NOTICE

March 14, 2008

Elkhorn Hazard Coal Land
Box 929
Whitesburg, KY 41858

RE: Public Notice-Public Service Commission of Kentucky (Case No. 2008-00089)

East Kentucky Network, LLC d/b/a Appalachian Wireless has applied to the Public Service Commission of Kentucky for a Certificate of Public Convenience and Necessity to construct and operate a new facility to provide cellular telecommunications service. The facility will include a 300 foot self supporting tower with attached antennas extending upwards, and an equipment shelter located approximately one and three quarter miles northwest of Blackey in Letcher County, Kentucky (37° 9' 20.7" N, 83° 0' 7.5"W). A map showing the location of the proposed new facility is enclosed. This notice is being sent to you because you may own property or reside within a 500' radius of the proposed tower.

The Commission invites your comments regarding the proposed construction. You also have the right to intervene in this matter. The Commission must receive your initial communication within 20 days of the date of this letter as shown above.

Your comments and request for intervention should be addressed to: Executive Director's Office, Public Service Commission of Kentucky, P.O. Box 615, Frankfort, KY 40602. Please refer to Case No. 2008-00089 in your correspondence.

Sincerely,

A handwritten signature in cursive script that reads "Janice Robinson".

Janice Robinson
Technical Site Coordinator
Enclosure 1

EAST KENTUCKY NETWORK
101 TECHNOLOGY TRAIL
IVEL, KY 41642
PHONE: (606) 874-7550
FAX: (606) 874-7551
INFO@EKN.COM
WEBSITE: WWW.EKN.COM



VIA: U.S. CERTIFIED MAIL

PUBLIC NOTICE

March 14, 2008

Elkhorn Hazard Coal Land
Box 929
Whitesburg, KY 41858

RE: Public Notice-Public Service Commission of Kentucky (Case No. 2008-00089)

East Kentucky Network, LLC d/b/a Appalachian Wireless has applied to the Public Service Commission of Kentucky for a Certificate of Public Convenience and Necessity to construct and operate a new facility to provide cellular telecommunications service. The facility will include a 300 foot self supporting tower with attached antennas extending upwards, and an equipment shelter located approximately one and three quarter miles northwest of Blackey in Letcher County, Kentucky (37° 9' 20.7" N, 83° 0' 7.5"W). A map showing the location of the proposed new facility is enclosed. This notice is being sent to you because you may own property or reside within a 500' radius of the proposed tower.

The Commission invites your comments regarding the proposed construction. You also have the right to intervene in this matter. The Commission must receive your initial communication within 20 days of the date of this letter as shown above.

Your comments and request for intervention should be addressed to: Executive Director's Office, Public Service Commission of Kentucky, P.O. Box 615, Frankfort, KY 40602. Please refer to Case No. 2008-00089 in your correspondence.

Sincerely,

A handwritten signature in cursive script that reads "Janice Robinson".

Janice Robinson
Technical Site Coordinator
Enclosure 1

EAST KENTUCKY NETWORK
101 TECHNOLOGY TRAIL
IVEL, KY 41642
PHONE: (606) 874-7550
FAX: (606) 874-7551
EMAIL: INFO@EKN.COM
WEBSITE: WWW.EKN.COM



VIA: U.S. CERTIFIED MAIL

PUBLIC NOTICE

March 14, 2008

Ethel Polly
Box 394
Elkhorn City, KY 41522

RE: Public Notice-Public Service Commission of Kentucky (Case No. 2008-00089)

East Kentucky Network, LLC d/b/a Appalachian Wireless has applied to the Public Service Commission of Kentucky for a Certificate of Public Convenience and Necessity to construct and operate a new facility to provide cellular telecommunications service. The facility will include a 300 foot self supporting tower with attached antennas extending upwards, and an equipment shelter located approximately one and three quarter miles northwest of Blackey in Letcher County, Kentucky (37° 9' 20.7" N, 83° 0' 7.5" W). A map showing the location of the proposed new facility is enclosed. This notice is being sent to you because you may own property or reside within a 500' radius of the proposed tower.

The Commission invites your comments regarding the proposed construction. You also have the right to intervene in this matter. The Commission must receive your initial communication within 20 days of the date of this letter as shown above.

Your comments and request for intervention should be addressed to: Executive Director's Office, Public Service Commission of Kentucky, P.O. Box 615, Frankfort, KY 40602. Please refer to Case No. 2008-00089 in your correspondence.

Sincerely,

A handwritten signature in cursive script that reads "Janice Robinson".

Janice Robinson
Technical Site Coordinator
Enclosure 1

EAST KENTUCKY NETWORK
101 TECHNOLOGY TRAIL
IVEL, KY 41642
PHONE: (606) 874-7550
FAX: (606) 874-7551
INFO@EKN.COM
WWW.EKN.COM



VIA: U.S. CERTIFIED MAIL

PUBLIC NOTICE

March 14, 2008

Francis & Stewart Whitaker
1050 Stewarts Rd
Blackey, KY 41804

RE: Public Notice-Public Service Commission of Kentucky (Case No. 2008-00089)

East Kentucky Network, LLC d/b/a Appalachian Wireless has applied to the Public Service Commission of Kentucky for a Certificate of Public Convenience and Necessity to construct and operate a new facility to provide cellular telecommunications service. The facility will include a 300 foot self supporting tower with attached antennas extending upwards, and an equipment shelter located approximately one and three quarter miles northwest of Blackey in Letcher County, Kentucky (37° 9' 20.7" N, 83° 0' 7.5"W). A map showing the location of the proposed new facility is enclosed. This notice is being sent to you because you may own property or reside within a 500' radius of the proposed tower.

The Commission invites your comments regarding the proposed construction. You also have the right to intervene in this matter. The Commission must receive your initial communication within 20 days of the date of this letter as shown above.

Your comments and request for intervention should be addressed to: Executive Director's Office, Public Service Commission of Kentucky, P.O. Box 615, Frankfort, KY 40602. Please refer to Case No. 2008-00089 in your correspondence.

Sincerely,

A handwritten signature in cursive script that reads "Janice Robinson".

Janice Robinson
Technical Site Coordinator
Enclosure 1

EAST KENTUCKY NETWORK
101 TECHNOLOGY TRAIL
IVEL, KY 41642
PHONE: (606) 874-7550
FAX: (606) 874-7551
: INFO@EKN.COM
RE: WWW.EKN.COM



VIA: U.S. CERTIFIED MAIL

PUBLIC NOTICE

March 14, 2008

Suzanne Whitaker Madden
562 Hill Top Farm Rd
Blackey, KY 41804

RE: Public Notice-Public Service Commission of Kentucky (Case No. 2008-00089)

East Kentucky Network, LLC d/b/a Appalachian Wireless has applied to the Public Service Commission of Kentucky for a Certificate of Public Convenience and Necessity to construct and operate a new facility to provide cellular telecommunications service. The facility will include a 300 foot self supporting tower with attached antennas extending upwards, and an equipment shelter located approximately one and three quarter miles northwest of Blackey in Letcher County, Kentucky (37° 9' 20.7" N, 83° 0' 7.5"W). A map showing the location of the proposed new facility is enclosed. This notice is being sent to you because you may own property or reside within a 500' radius of the proposed tower.

The Commission invites your comments regarding the proposed construction. You also have the right to intervene in this matter. The Commission must receive your initial communication within 20 days of the date of this letter as shown above.

Your comments and request for intervention should be addressed to: Executive Director's Office, Public Service Commission of Kentucky, P.O. Box 615, Frankfort, KY 40602. Please refer to Case No. 2008-00089 in your correspondence.

Sincerely,

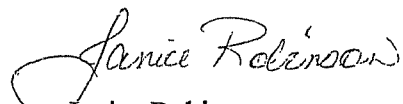
Janice Robinson
Technical Site Coordinator
Enclosure 1

EAST KENTUCKY NETWORK
101 TECHNOLOGY TRAIL
IVEL, KY 41642
PHONE: (606) 874-7550
FAX: (606) 874-7551
INFO@EKN.COM
SITE: WWW.EKN.COM



VIA: U.S. CERTIFIED MAIL

PUBLIC NOTICE

March 14, 2008

Charles & Joyce Whitaker
14 Stewarts Rd
Blackey, KKY 41804

RE: Public Notice-Public Service Commission of Kentucky (Case No. 2008-00089)

East Kentucky Network, LLC d/b/a Appalachian Wireless has applied to the Public Service Commission of Kentucky for a Certificate of Public Convenience and Necessity to construct and operate a new facility to provide cellular telecommunications service. The facility will include a 300 foot self supporting tower with attached antennas extending upwards, and an equipment shelter located approximately one and three quarter miles northwest of Blackey in Letcher County, Kentucky (37° 9' 20.7" N, 83° 0' 7.5"W). A map showing the location of the proposed new facility is enclosed. This notice is being sent to you because you may own property or reside within a 500' radius of the proposed tower.

The Commission invites your comments regarding the proposed construction. You also have the right to intervene in this matter. The Commission must receive your initial communication within 20 days of the date of this letter as shown above.

Your comments and request for intervention should be addressed to: Executive Director's Office, Public Service Commission of Kentucky, P.O. Box 615, Frankfort, KY 40602. Please refer to Case No. 2008-00089 in your correspondence.

Sincerely,

A handwritten signature in cursive script that reads "Janice Robinson".

Janice Robinson
Technical Site Coordinator
Enclosure 1

Location Map

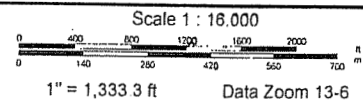
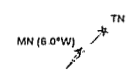
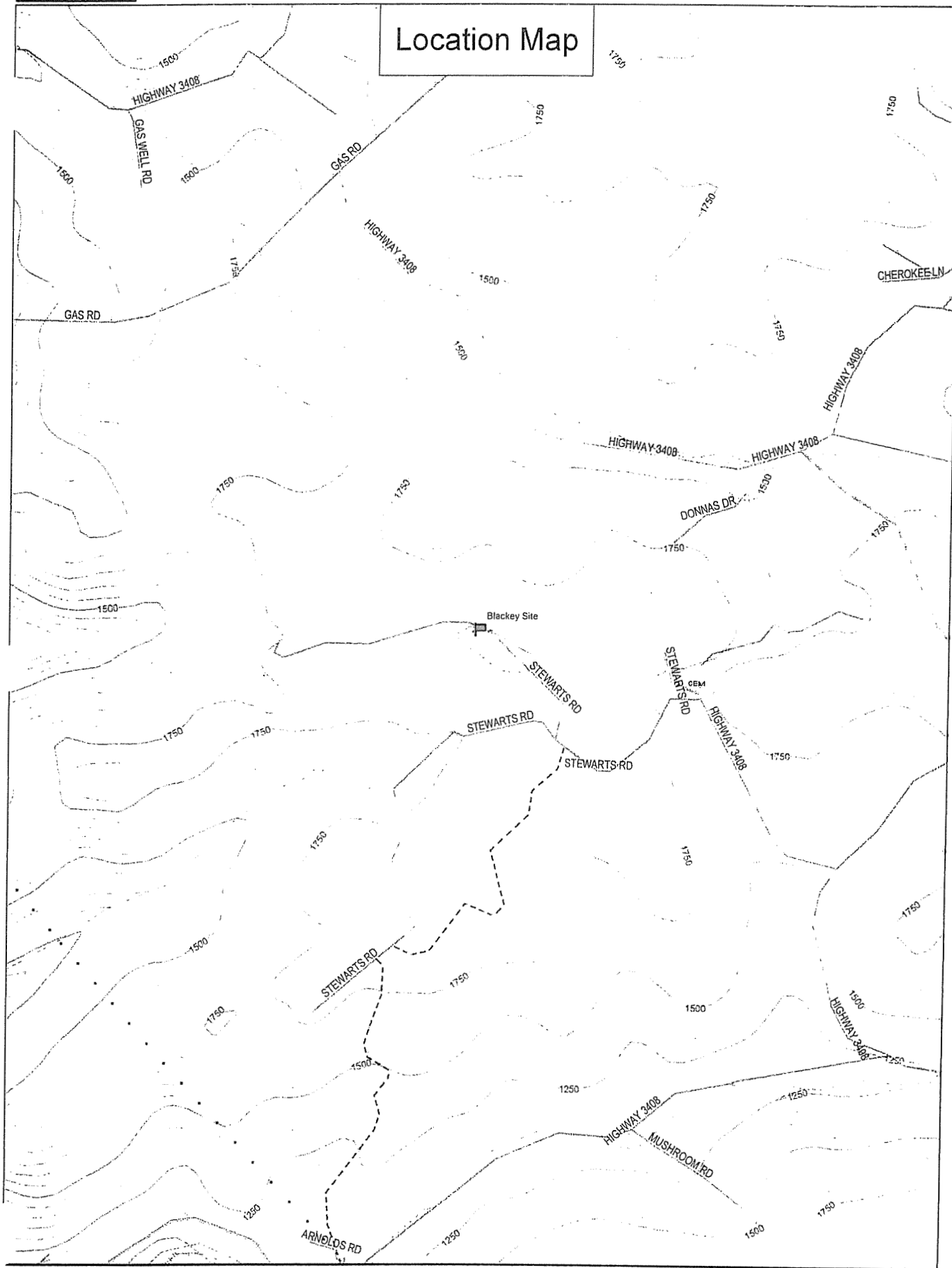

WENDELL R. HOLMES, P.G.
120 Church Street
Whitesburg, KY 41858
(606) 633-1511

February 14, 2008

Blackey Tower Site

Purpose:

A site assessment was conducted for Appalachian Wireless on a tract of land located in Letcher County near Blackey, Kentucky. The site of the proposed tower is now a forestland. The purpose of this investigation was to determine the depth to bedrock and of what type of rock the bedrock consists.

Site Investigation:

The trenching method was used to determine the type of bedrock material at the proposed tower site. A Caterpillar 320 excavator was used to expose the bedrock material. It is approximately 7.00 feet to the sandy shale bedrock. (See attached page for descriptions of materials encountered.)

The terrain in Letcher County is moderately to very steep. The tower site is located on a ridge between Orchard Branch and Bull Creek, both being tributaries of the North Fork of the Kentucky River, approximately one and three quarter miles northwest of Blackey in Letcher County. The sandstone formation below the tower site is approximately 10.00 feet thick, based on the information obtained from the site investigation and geological maps of the area.

Conclusions:

The proposed tower site is located on a ridge in the area. The sandy shale bedrock on the proposed tower site is part of the Breathitt Formation, and is middle to lower Pennsylvanian in age. Tests were not conducted to determine the load-bearing strength of the bedrock. However, it is apparent that the tower will be constructed on the sandstone bedrock formation.

The field work for this site was performed by Wendell R. Holmes, using generally accepted methods in the practice of geological science.

Wendell R. Holmes, P.G.

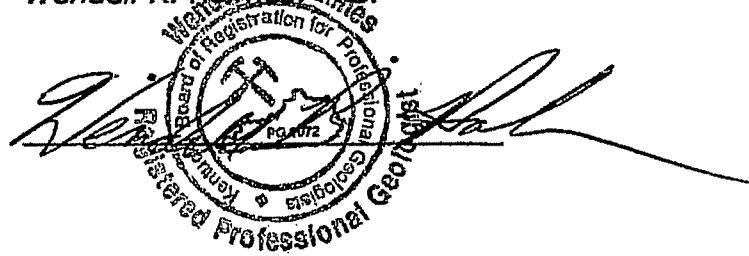

WENDELL R. HOLMES, P.G.

120 Church Street
Apartment 3
Whitesburg, Ky. 41858
(606)633-1511

Geologist Log

Location: Blackey Tower Site

Unit Thickness	Total depth	Strata	Description
2.00'	2.00'	Soil	Yellow and Brown, with Shale Fragments
5.00'	7.00'	shale	Brown, gray and Weathered
10.00'	17.00'	Sandy shale	Brown and Gray

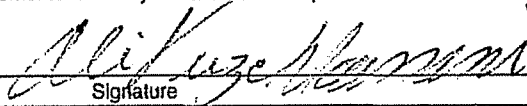
Kentucky Transportation Cabinet, Kentucky Airport Zoning Commission, 200 Mero Street, Frankfort, KY 40622 APPLICATION FOR PERMIT TO CONSTRUCT OR ALTER A STRUCTURE INSTRUCTIONS INCLUDED	Kentucky Aeronautical Study Number
1 LICANT -- Name, Address, Telephone, Fax, etc Kentucky Network, LLC c/o Lukas, Nace, Gutierrez & Sachs, Chtd 1650 Tysons Blvd, Suite 1500 McLean, VA 22102 T: 703-584-8667 F: 703-584-8692	9 Latitude: <u>37</u> ° <u>09</u> ' <u>20</u> " <u>7</u> " 10 Longitude: <u>83</u> ° <u>00</u> ' <u>07</u> " <u>5</u> " 11 Datum: <input checked="" type="checkbox"/> NAD83 <input type="checkbox"/> NAD27 <input type="checkbox"/> Other _____ 12 Nearest Kentucky City: <u>Blakey</u> County <u>Letcher</u> 13 Nearest Kentucky public use or Military airport: <u>Wendell H Ford</u> 14 Distance from #13 to Structure: <u>21.6</u> miles 15 Direction from #13 to Structure: <u>SE</u> 16 Site Elevation (AMSL): <u>2,030.00</u> Feet 17 Total Structure Height (AGL): <u>320.00</u> Feet 18 Overall Height (#16 + #17) (AMSL): <u>2,350.00</u> Feet 19 Previous FAA and/or Kentucky Aeronautical Study Number(s): _____ 20 Description of Location: (Attach USGS 7.5 minute Quadrangle Map or an Airport layout Drawing with the precise site marked and any certified survey) Site is located approx 1.4 mi (2.3 km) NNW of Lakey (Letcher), KY
2 Representative of Applicant -- Name, Address, Telephone, Fax Ali Kuzehkanani Lukas, Nace, Gutierrez & Sachs, Chtd 1650 Tysons Blvd, Suite 1500 McLean, VA 22102 T: 703-584-8667 F: 703-584-8692	
3 Application for: <input checked="" type="checkbox"/> New Construction <input type="checkbox"/> Alteration <input type="checkbox"/> Existing 4 Duration: <input checked="" type="checkbox"/> Permanent <input type="checkbox"/> Temporary (Months _____ Days _____) 5 Work Schedule: Start <u>4/1/2008</u> End <u>4/15/2008</u> 6 Type: <input checked="" type="checkbox"/> Antenna Tower <input type="checkbox"/> Crane <input type="checkbox"/> Building <input type="checkbox"/> Power Line <input type="checkbox"/> Landfill <input type="checkbox"/> Water Tank <input type="checkbox"/> Other _____ 7 Lighting/Painting and/or Lighting Preferred: <input type="checkbox"/> Lights and Paint <input checked="" type="checkbox"/> Dual - Red & Medium Intensity White <input type="checkbox"/> White - Medium Intensity <input type="checkbox"/> Dual - Red & High Intensity White <input type="checkbox"/> White - High Intensity <input type="checkbox"/> Other _____ 8 FAA Aeronautical Study Number _____	
21 Description of Proposal: The structure will include a 300' tower with top-mounted antennas (overall height of 320' AGL). The ERP will be 500 watts	
22. Has a "NOTICE OF CONSTRUCTION OR ALTERATION" (FAA Form 7460-1) been filed with the Federal Aviation Administration? <input type="checkbox"/> No <input checked="" type="checkbox"/> Yes, When <u>March 10, 2008</u>	
CERTIFICATION: I hereby certify that all the above statements made by me are true, complete and correct to the best of my knowledge and belief	
Ali Kuzehkanani/ Dir of Engineering Printed Name and Title	 Signature
	3/10/2008 Date
PENALTIES: Persons failing to comply with Kentucky Revised Statutes (KRS 183.861 through 183.990) and Kentucky Administrative Regulations (602 KAR 050:Series) are liable for fines and/or imprisonment as set forth in KRS 183.990(3). Non-compliance with Federal Aviation Administration Regulations may result in further penalties.	
Commission Action: <input type="checkbox"/> Chairman, KAZC <input type="checkbox"/> Administrator, KAZC <input type="checkbox"/> Approved _____ <input type="checkbox"/> Disapproved _____ Date _____	

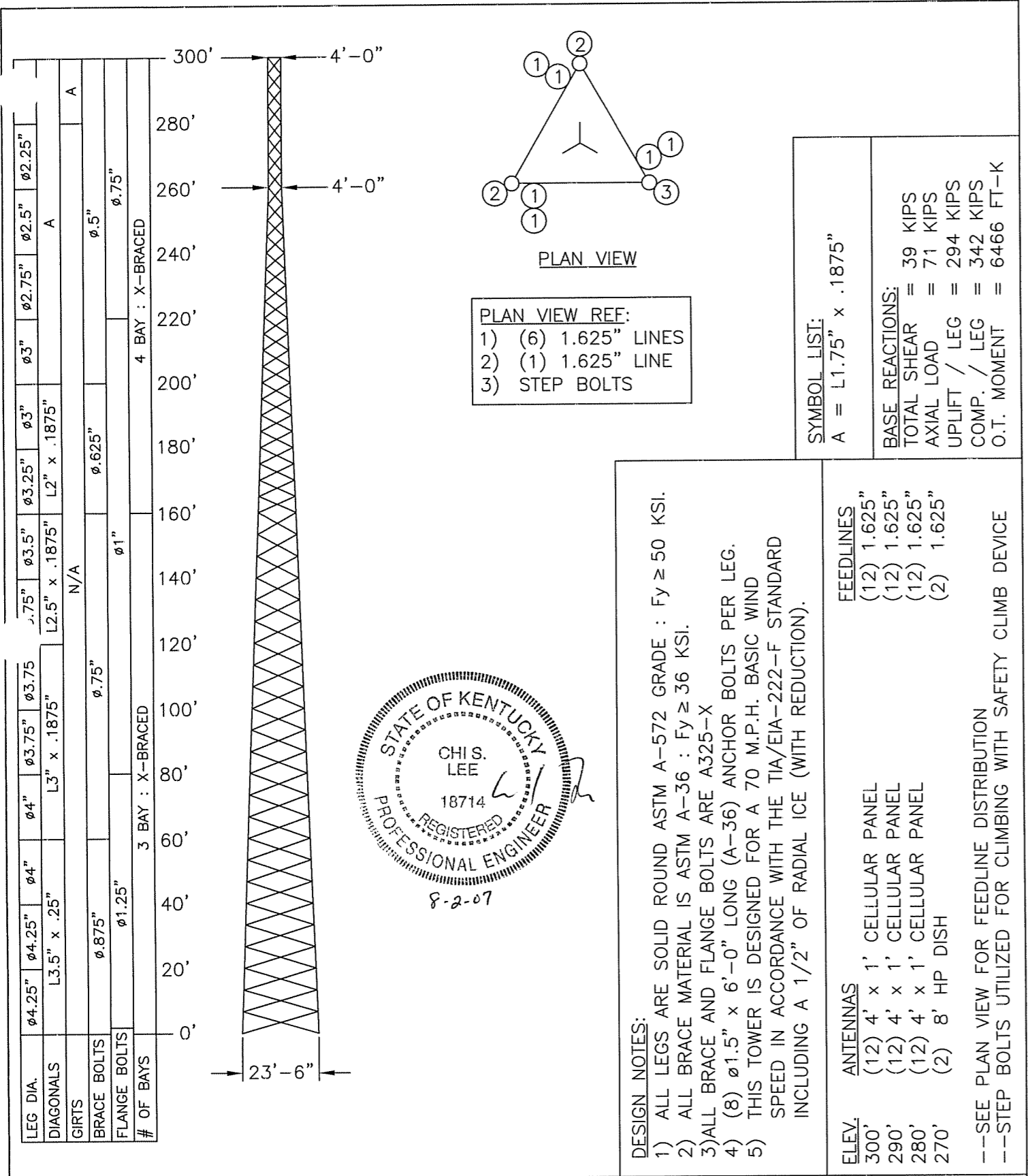

DESIGN NOTES:

- 1) ALL LEGS ARE SOLID ROUND ASTM A-572 GRADE : $F_y \geq 50$ KSI.
- 2) ALL BRACE MATERIAL IS ASTM A-36 : $F_y \geq 36$ KSI.
- 3) ALL BRACE AND FLANGE BOLTS ARE A325-X
- 4) (8) $\phi 1.5$ " x 6'-0" LONG (A-36) ANCHOR BOLTS PER LEG.
- 5) THIS TOWER IS DESIGNED FOR A 70 M.P.H. BASIC WIND SPEED IN ACCORDANCE WITH THE TIA/EIA-222-F STANDARD INCLUDING A 1/2" OF RADIAL ICE (WITH REDUCTION).

FEEDLINES

ELEV.	ANTENNAS
300'	(12) 4' x 1' CELLULAR PANEL
290'	(12) 4' x 1' CELLULAR PANEL
280'	(12) 4' x 1' CELLULAR PANEL
270'	(2) 8' HP DISH

--SEE PLAN VIEW FOR FEEDLINE DISTRIBUTION
 --STEP BOLTS UTILIZED FOR CLIMBING WITH SAFETY CLIMB DEVICE

P.O. BOX 25
 HENDERSON, KY 42419
 PHONE: (270) 830-8512
 FAX: (270) 830-8475

SCALE: N.T.S.	PROPRIETARY STATEMENT: THIS DRAWING IS THE PROPERTY OF ALLSTATE TOWER CO. IT IS NOT TO BE REPRODUCED OR COPIED IN ANYWAY WITHOUT PRIOR WRITTEN CONSENT OF ALLSTATE TOWER CO.
TOLERANCE BANDS ALL DIMENSIONS ARE $\pm 1/16$ " ALL ANGULAR DIM ARE $\pm 1/2$ " UNLESS OTHERWISE NOTED	CUSTOMER: APPALACHIAN WIRELESS DESCRIPTION: 300' SELF SUPPORT TOWER LOCATION: LETCHER COUNTY, KY. SITE: BLACKKEY
APPROX WEIGHT 50.94 KIPS	PROPOSAL #: AB1508 - S.S.T. PROPOSAL
	DRAWN BY: J.B. DATE: 08/01/2007 REV: REV. NO. REV DATE: REV. DATE
	JOB NO AB1508
	SHEET A



P.O. BOX 25
 HENDERSON, KY 42419
 PHONE: (270) 830-8512
 FAX: (270) 830-8475

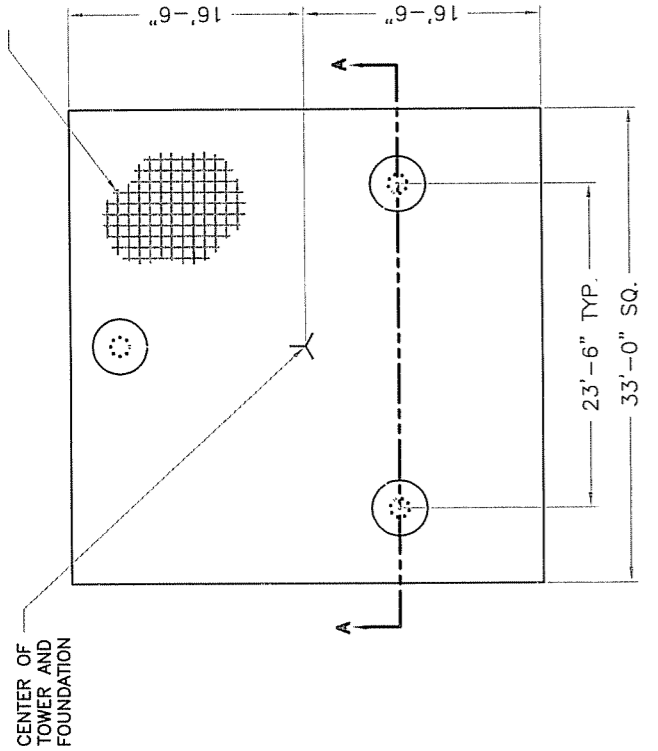

PLAN VIEW

TOTAL VOLUME OF CONCRETE = 85 YD³

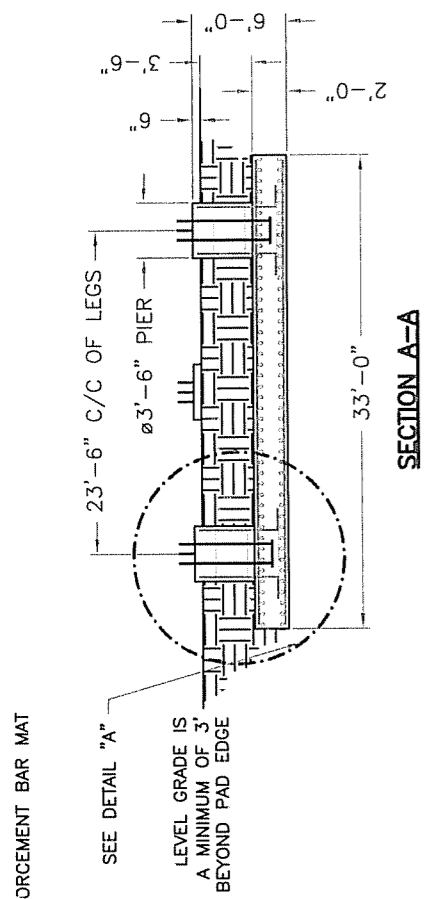

SECTION A-A

(8) ø1-1/2" x 6'-0" OVERALL LENGTH ANCHOR BOLTS W/ 3/4" THK BEARING PLATE AT THE BOTTOM OF THE ANCHOR BOLT CLUSTER (5' MIN. ANCHOR BOLT EMBEDMENT).

USE EPOXY BONDING AGENT WHEN POURED SEPERATELY

(10) #9 VERTICAL BARS w/ #4 TIES AT 12" ON CENTER

(34) #9 HORIZONTAL BARS x 32'-6" LONG EQUALLY SPACED EACH WAY AT TOP AND BOTTOM OF MAT. (TOTAL = 136)

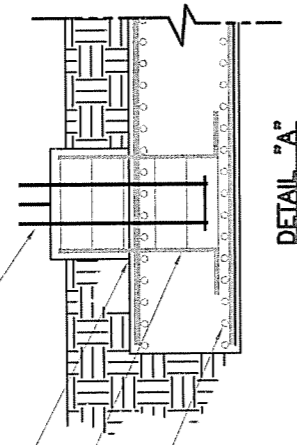

DETAIL "A"

FOUNDATION INSTALLATION/DESIGN NOTES:

- THIS FOUNDATION IS DESIGNED TO MEET ALL STANDARDS SET FORTH BY ACI 318: AMERICAN CONCRETE INSTITUTE, BUILDING CODE REQUIREMENTS FOR STRUCTURAL CONCRETE, ANSI/TIA/EIA 222-F: STRUCTURAL STANDARDS FOR STEEL ANTENNA TOWERS AND ANTENNA SUPPORTING STRUCTURES. THIS FOUNDATION IS DESIGNED UTILIZING NORMAL SOIL CONDITIONS.
- ALL WORK PERFORMED FROM THESE DRAWINGS SHOULD BE BY QUALIFIED CONTRACTORS EXPERIENCED IN TOWER FOUNDATION CONSTRUCTION.
- ALL FOOTING EXCAVATIONS SHALL BE MANUALLY CLEANED PRIOR TO PLACING CONCRETE. COMPACT THE EXPOSED SOIL SURFACE AND ANY GRANULAR FILL UNDER THE FOUNDATION TO 95% OF THE MODIFIED PROCTOR DENSITY. ALL CONCRETE SHALL HAVE A MINIMUM COMPRESSIVE STRENGTH OF 3000 PSI AFTER 28 DAYS. COPIES OF THE CONCRETE CYLINDER TEST REPORTS SHALL BE SENT TO THE RESIDENT ENGINEER / INSPECTOR.
- MINIMUM CONCRETE COVER FOR REINFORCING BARS SHALL BE 3".
- FIELD BENDING OR WELDING OF REINFORCEMENT BARS IS NOT PERMITTED. PROVIDE CHAMFERS AT ALL EXPOSED CORNERS OF CONCRETE.
- BACKFILL NEAR AND AROUND THE FOUNDATIONS SHALL BE A WELL GRADED FILL MATERIAL PLACED IN 8" THICK LAYERS THAT HAS BEEN COMPACTED TO 95% OF THE MODIFIED PROCTOR DENSITY PER ASTM D1557.
- SOME DETAIL HAS BEEN PURPOSELY OMITTED TO CLARIFY ILLUSTRATION.

REINFORCEMENT BAR SPlicing:

- ALL LAP SPICES SHALL CONFORM TO ACI 318 REQUIREMENTS.
- REFER TO CHART BELOW WHEN REINFORCEMENT BAR SPlicing IS NECESSARY.

REINFORCING BAR SIZE	LAP SPlice LENGTH
3	15"
4	17"
5	21"
6	26"
7	30"
8	36"
9	46"
10	58"
11	71"

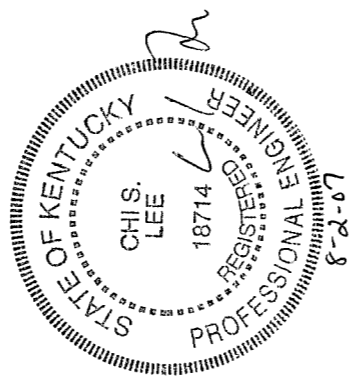

SCALE: N.T.S.	PROPRIETARY STATEMENT: THIS DRAWING IS THE PROPERTY OF ALLSTATE TOWER CO. IT IS NOT TO BE REPRODUCED OR COPIED IN ANYWAY WITHOUT PRIOR WRITTEN CONSENT OF ALLSTATE TOWER CO.		
TOLERANCE BANDS ALL DIMENSIONS ARE ±1/16" ALL ANGULAR DIM ARE ±1/2° UNLESS OTHERWISE NOTED	CUSTOMER: APPALACHIAN WIRELESS	DATE: 07/03/2007	DRAWN BY: J.B.
	DESCRIPTION: PAD/PIER FOUNDATION DESIGN	REV. DATE: REV. DATE	REV. NO. REV. NO.
	LOCATION: LECHTER COUNTY, KY.	JOB NO. AB1508	SHEET B
APPROX. WEIGHT N/A	PROPOSAL # AB1483 - S.S.T. PROPOSAL		

LUKAS, NACE, GUTIERREZ & SACHS

ARTERED

1650 TYSONS BOULEVARD, SUITE 1500
MCLEAN, VIRGINIA 22102
703 584 8678 • 703 584 8696 FAX

WWW.FCCLAW.COM

RUSSELL D LUKAS
DAVID L NACE
THOMAS GUTIERREZ*
ELIZABETH R SACHS*
GEORGE L LYON, JR
PAMELA L GIST
DAVID A LAFURIA
TODD SLAMOWITZ*
B LYNN F RATNAVALE*
STEVEN M CHERNOFF*
KATHERINE PATSAS*

CONSULTING ENGINEERS
ALI KUZEHKANANI
LEILA REZANAVAZ
OF COUNSEL
LEONARD S KOLSKY*
JOHN CIMKO*
J K HAGE III*
JOHN J MCAVOY*
HON GERALD S MCGOWAN*
TAMARA DAVIS-BROWN*

*NOT ADMITTED IN VA
Writers Direct Dial
(703) 584-8667
akuzehkanani@lcr law.com

March 10, 2008

Via U.S. Mail

EXPRESS PROCESSING CENTER
Federal Aviation Administration
Southwest Regional Office
Air Traffic Airspace Branch, ASW-520
2601 Meacham Blvd.
Fort Worth, TX 76137-4298

Dear FAA Evaluator:

Enclosed is an FAA Form 7460-1 (Notice of Proposed Construction or Alteration) for a new 320' communications tower structure (300' tower plus 20' antenna) near Blakey (Letcher), Kentucky. The site ("Blakey") is approximately 1.4 mi (2.3 kilometers) NNW of town of Blakey.

The proponent, East Kentucky Network, LLC, is the licensee for Cellular Block B service in Kentucky 10 - Powell Rural Service Area (KY10B RSA), Market No. 452B. Transmit technology to be employed at this station is CDMA in the Cellular Band B frequency band (880 -890 MHz and 891 - 894 MHz); the maximum ERP is 500 Watts.

Should you have any questions or require additional information, please do not hesitate to call the undersigned at the above identified telephone number.

Sincerely,

Ali Kuzehkanani
Director of Engineering

Enclosure

cc: East Kentucky Network, LLC
Attention: Marty Thacker and Gerald Robinett

Notice of Proposed Construction or Alteration - Off Airport

Project Name: EAST -000089915-08

Sponsor: East Kentucky Network, LLC

Details for Case : Blakey

Show Project Summary

Case Status

ASN: 2008-ASO-1274-OE
 Status: Accepted

Date Accepted: 03/10/2008
 Date Determined:
 Letters: None

Construction / Alteration Information

Notice Of: Construction
 Duration: Permanent
if Temporary : Months: Days:
 Work Schedule - Start: 04/01/2008
 Work Schedule - End: 04/15/2008
 State Filing: Filed with State

Structure Summary

Structure Type: Tower
 Structure Name: Blakey
 FCC Number:
 Prior ASN:

Structure Details

Latitude: 37° 9' 20.7" N
 Longitude: 83° 0' 7.5" W
 Horizontal Datum: NAD83
 Site Elevation (SE): 2030 (nearest foot)
 Structure Height (AGL): 320 (nearest foot)
 Marking/Lighting: Dual-red and medium intensity

Other :

Nearest City: Blackey
 Nearest State: Kentucky

Description of Location: Site is located approx. 1.4 mi (2.3 km) NNW of Blakey (Letcher), KY

Description of Proposal: A new 300' tower plus top-mounted antennas (overall height of 320' AGL).

Common Frequency Bands

Low Freq	High Freq	Freq Unit	ERP	ERP Unit
806	824	MHz	500	W
824	849	MHz	500	W
851	866	MHz	500	W
869	894	MHz	500	W
896	901	MHz	500	W
901	902	MHz	7	W
930	931	MHz	3500	W
931	932	MHz	3500	W
932	932.5	MHz	17	dBW
935	940	MHz	1000	W
940	941	MHz	3500	W
1850	1910	MHz	1640	W
1930	1990	MHz	1640	W
2305	2310	MHz	2000	W
2345	2360	MHz	2000	W

Specific Frequencies

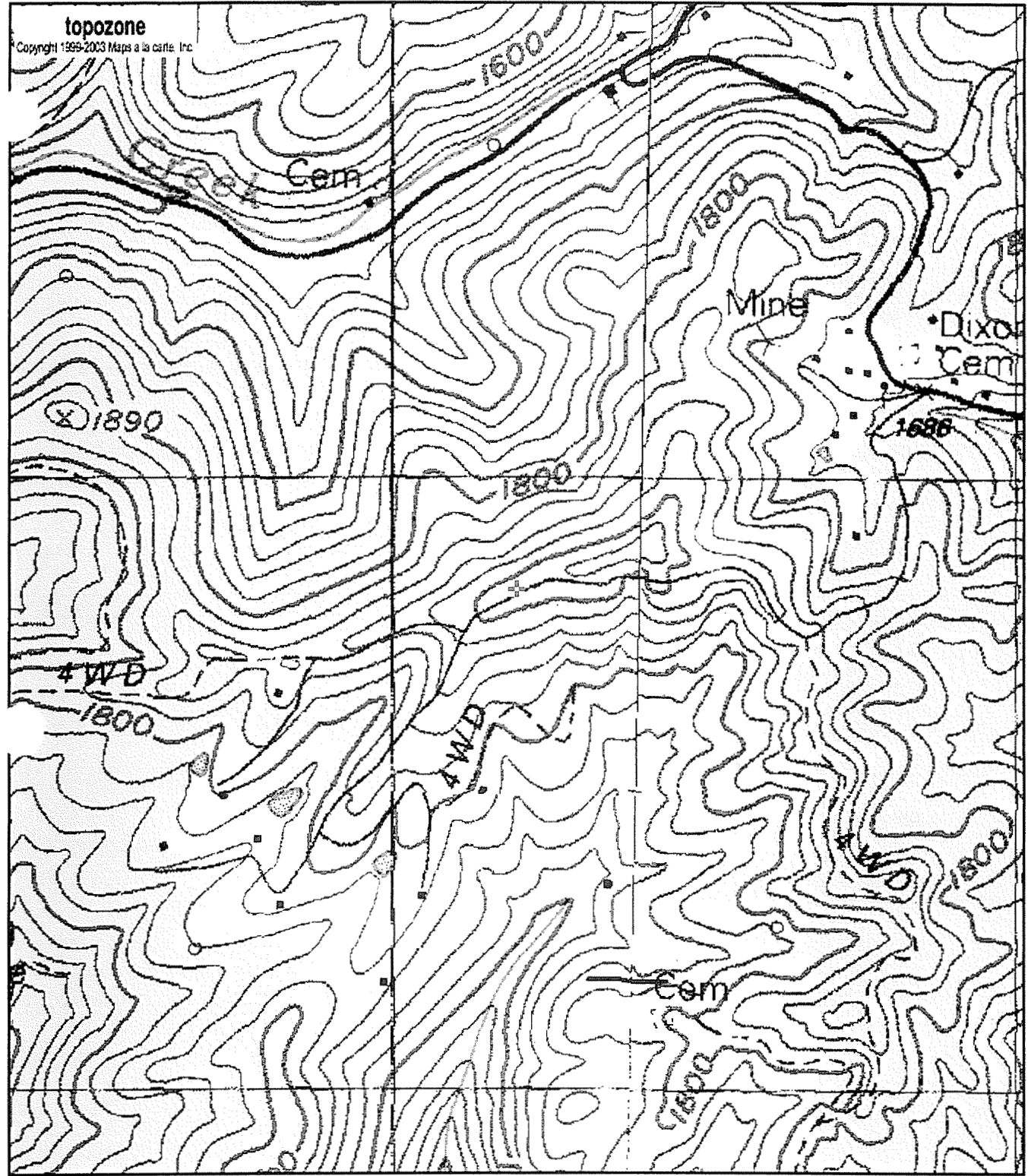

0 0.1 0.2 0.3 0.4 0.5 km
0 0.09 0.18 0.27 0.36 0.45 mi
37° 09' 21"N, 83° 00' 08"W (NAD83/WGS84)
USGS Vicco (KY) Quadrangle
Projection is UTM Zone 17 NAD83 Datum

Mpk
M=-5.954
G=-1.21

EAST KENTUCKY NETWORK, LLC
DBA APPALACHIAN WIRELESS

FINANCIAL REPORT

December 31, 2006

CONTENTS

	Page
INDEPENDENT AUDITOR'S REPORT ON THE FINANCIAL STATEMENTS	1
FINANCIAL STATEMENTS	
Balance sheets	2
Statements of income	3
Statements of members' equity	4
Statements of cash flows	5-6
Notes to financial statements	7-13
INDEPENDENT AUDITOR'S REPORT ON THE SUPPLEMENTARY INFORMATION	14
SUPPLEMENTARY INFORMATION	
Statement of income detail	15 and 16

INDEPENDENT AUDITOR'S REPORT

To the Members
East Kentucky Network, LLC
dba Appalachian Wireless
Ivel, Kentucky 41642

We have audited the accompanying balance sheets of East Kentucky Network, LLC, dba Appalachian Wireless as of December 31, 2006 and 2005 and the related statements of income, members' equity and cash flows for the years then ended. These financial statements are the responsibility of the Company's management. Our responsibility is to express an opinion on these financial statements based on our audits.

We conducted our audits in accordance with auditing standards generally accepted in the United States of America. Those standards require that we plan and perform the audit to obtain reasonable assurance about whether the financial statements are free of material misstatement. An audit includes examining, on a test basis, evidence supporting the amounts and disclosures in the financial statements. An audit also includes assessing the accounting principles used and significant estimates made by management, as well as evaluating the overall financial statement presentation. We believe that our audits provide a reasonable basis for our opinion.

In our opinion, the financial statements referred to above present fairly, in all material respects, the financial position of East Kentucky Network, LLC, dba Appalachian Wireless as of December 31, 2006 and 2005 and the results of its operations and its cash flows for the years then ended in conformity with accounting principles generally accepted in the United States of America.

Jones, Nale & Mattungly PLC

Louisville, Kentucky
March 15, 2007

EAST KENTUCKY NETWORK, LLC
DBA APPALACHIAN WIRELESS

BALANCE SHEETS
December 31, 2006 and 2005

ASSETS	<u>2006</u>	<u>2005</u>
CURRENT ASSETS		
Cash and cash equivalents	\$ 2,818,346	\$ 1,046,669
Short-term investments	46,271	43,803
Accounts receivable, less allowance for doubtful accounts of \$567,790 in 2006 and \$375,856 in 2005	2,802,673	1,560,267
Accounts receivable, members (Notes 5 and 6)	37,612	3,149
USF receivable (Note 7)	--	589,913
Inventory	1,584,039	1,056,766
Prepaid expenses	173,657	143,547
Total current assets	<u>\$ 7,462,598</u>	<u>\$ 4,444,114</u>
 PROPERTY, PLANT AND EQUIPMENT (Note 3)		
Plant in service:		
General support	\$ 18,914,927	\$ 10,633,736
MTSO equipment	13,354,875	11,934,434
Cell equipment	39,339,797	34,785,982
Paging equipment	3,321,068	3,320,416
Fiber ring	6,471,128	6,245,412
Unfinished plant	657,524	3,992,696
	<u>\$ 82,059,319</u>	<u>\$ 70,912,676</u>
Less accumulated depreciation	<u>33,358,066</u>	<u>27,810,940</u>
	<u>\$ 48,701,253</u>	<u>\$ 43,101,736</u>
 OTHER ASSETS		
Investment in affiliated company, RTFC (Note 3)	\$ 862,394	\$ 875,133
Intangible assets, net of accumulated amortization of \$2,646,913 in 2006 and \$2,179,654 in 2005 (Note 2)	4,497,032	4,623,855
Other	27,550	28,669
	<u>\$ 5,386,976</u>	<u>\$ 5,527,657</u>
	<u>\$ 61,550,827</u>	<u>\$ 53,073,507</u>

The Notes to Financial Statements are an integral part of these statements.

LIABILITIES AND MEMBERS' EQUITY	<u>2006</u>	<u>2005</u>
CURRENT LIABILITIES		
Current maturities of long-term debt (Note 3)	\$ 1,200,000	\$ 48,033
Accounts payable	1,166,909	851,643
Accounts payable, member (Notes 5 and 6)	2,899	2,936
Accrued expenses	2,113,530	1,457,463
Accrued state corporation taxes	232,157	85,989
Customer deposits	<u>317,603</u>	<u>291,380</u>
Total current liabilities	\$ 5,033,098	\$ 2,737,444
LONG-TERM DEBT, less current maturities (Note 3)	13,000,000	13,297,220
MEMBERS' EQUITY	43,517,729	37,038,843
	<u>\$ 61,550,827</u>	<u>\$ 53,073,507</u>

EAST KENTUCKY NETWORK, LLC
DBA APPALACHIAN WIRELESS

STATEMENTS OF INCOME
Years Ended December 31, 2006 and 2005

	2006	2005
REVENUE		
Retail	\$ 24,156,320	\$ 20,908,570
Roamer	6,964,309	6,868,904
Long distance	155,046	177,350
Paging	852,011	1,039,429
Equipment sales, cellular	2,922,817	2,152,962
Equipment sales, paging	27,894	57,632
Other	3,065,078	2,359,809
Total revenue	\$ 38,143,475	\$ 33,564,656
EXPENSES		
Cost of cellular service	\$ 7,888,446	\$ 7,924,553
Cost of paging service	411,177	510,665
Cost of equipment sales, cellular	6,813,457	4,912,998
Cost of equipment sales, paging	58,755	78,428
Customer service	1,330,573	1,208,726
Billing	1,097,834	1,200,135
Selling	2,703,570	2,131,009
Maintenance	1,267,034	1,042,844
Utilities	454,008	354,870
Bad debts	800,268	672,263
Recovery of bad debts	(90,925)	(120,673)
Cell site rental	158,500	135,012
Taxes	565,271	257,247
Advertising	1,574,298	1,139,697
General and administrative	2,238,348	2,249,226
Occupancy	334,981	359,928
Depreciation	5,541,628	4,635,200
Amortization	508,526	495,241
Total expenses	\$ 33,655,749	\$ 29,187,369
Income from operations	\$ 4,487,726	\$ 4,377,287
OTHER INCOME (EXPENSE)		
Interest income	\$ 49,052	\$ 23,915
Interest expense	(821,277)	(795,898)
Universal Service Fund income (Note 7)	3,716,602	589,913
Impairment of goodwill (Note 8)	--	(331,286)
	\$ 2,944,377	\$ (513,356)
Income before taxes	\$ 7,432,103	\$ 3,863,931
Kentucky corporation tax expense	399,157	170,197
Net income	\$ 7,032,946	\$ 3,693,734

The Notes to Financial Statements are an integral part of these statements.

EAST KENTUCKY NETWORK, LLC
DBA APPALACHIAN WIRELESS

STATEMENTS OF MEMBERS' EQUITY
Years Ended December 31, 2006 and 2005

	Cellular Services, Inc.	Gearhart Communi- cations Company, Inc.	Mountain Tele- communi- cations, Inc.	Thacker- Grigsby Telephone Co., Inc.	Peoples Rural Telephone Coop- erative Corp- oration, Inc.	Total
Balance, January 1, 2005	\$ 6,781,309	\$ 6,781,309	\$ 6,781,309	\$ 6,781,309	\$ 6,781,308	\$33,906,544
Net income	738,747	738,747	738,747	738,746	738,747	3,693,734
Capital distributions	(112,287)	(112,287)	(112,287)	(112,287)	(112,287)	(561,435)
Balance, December 31, 2005	\$ 7,407,769	\$ 7,407,769	\$ 7,407,769	\$ 7,407,768	\$ 7,407,768	\$37,038,843
Net income	1,406,589	1,406,589	1,406,589	1,406,590	1,406,589	7,032,946
Capital distributions	(110,812)	(110,812)	(110,812)	(110,812)	(110,812)	(554,060)
Balance, December 31, 2006	<u>\$ 8,703,546</u>	<u>\$ 8,703,546</u>	<u>\$ 8,703,546</u>	<u>\$ 8,703,546</u>	<u>\$ 8,703,545</u>	<u>\$43,517,729</u>

The Notes to Financial Statements are an integral part of these statements.

EAST KENTUCKY NETWORK, LLC
DBA APPALACHIAN WIRELESS

STATEMENTS OF CASH FLOWS
Years Ended December 31, 2006 and 2005

	2006	2005
CASH FLOWS FROM OPERATING ACTIVITIES		
Net income	\$ 7,032,946	\$ 3,693,734
Adjustments to reconcile net income to net cash provided by operating activities:		
Depreciation	5,541,628	4,635,200
Amortization	508,526	495,241
Impairment of goodwill	--	331,286
Changes in assets and liabilities, net of the effects of investing and financing activities:		
(Increase) in accounts receivable	(1,242,406)	(78,367)
Decrease in accounts receivable, members	(34,463)	51,248
(Increase) decrease in USF receivable	589,913	(589,913)
(Increase) in inventory	(527,273)	(230,130)
(Increase) decrease in prepaid expenses	(30,110)	5,012
(Increase) decrease in other assets	13,858	(646)
Increase (decrease) in accounts payable	315,266	(291,123)
Increase (decrease) in accounts payable, member	(37)	2,332
Increase in accrued expenses	656,067	339,038
Increase in accrued state corporation taxes	146,168	85,989
Increase in customer deposits	26,223	139,030
Net cash provided by operating activities	\$ 12,996,306	\$ 8,587,931
CASH FLOWS FROM INVESTING ACTIVITIES		
Purchase of property, plant and equipment	\$ (11,182,411)	\$ (11,469,668)
Purchase of intangible assets	(340,437)	(299,159)
Proceeds from sale of short-term investments	(2,468)	56,197
Net cash (used in) investing activities	\$ (11,525,316)	\$ (11,712,630)
CASH FLOWS FROM FINANCING ACTIVITIES		
Capital distributions	\$ (554,060)	\$ (561,435)
Proceeds from long-term borrowings	14,200,000	3,450,000
Payments on long-term borrowings	(13,345,253)	(832,731)
Net cash provided by financing activities	\$ 300,687	\$ 2,055,834
Net increase (decrease) in cash and cash equivalents	\$ 1,771,677	\$ (1,068,865)
Cash and cash equivalents:		
Beginning	1,046,669	2,115,534
Ending	\$ 2,818,346	\$ 1,046,669

The Notes to Financial Statements are an integral part of these statements.

EAST KENTUCKY NETWORK, LLC
DBA APPALACHIAN WIRELESS

STATEMENTS OF CASH FLOWS (Continued)
Years Ended December 31, 2006 and 2005

	<u>2006</u>	<u>2005</u>
SUPPLEMENTAL DISCLOSURE OF CASH FLOW INFORMATION		
Cash payments for interest	<u>\$ 866,941</u>	<u>\$ 788,610</u>
Cash payments for state corporation taxes	<u>\$ 167,000</u>	<u>\$ 84,207</u>
SUPPLEMENTAL SCHEDULE OF NONCASH INVESTING AND FINANCING ACTIVITIES		
Settlement of note payable from impairment of goodwill	<u>\$ --</u>	<u>\$ 400,000</u>
Settlement of accrued interest from impairment of goodwill	<u>\$ --</u>	<u>\$ 56,000</u>

The Notes to Financial Statements are an integral part of these statements.

**EAST KENTUCKY NETWORK, LLC
DBA APPALACHIAN WIRELESS**

NOTES TO FINANCIAL STATEMENTS

Note 1. Summary of Significant Accounting Policies

Nature of operations

East Kentucky Network, LLC, dba Appalachian Wireless, is a Kentucky limited liability company formed by the merger of Appalachian Cellular, LLC, Mountaineer Cellular, LLC and East Kentucky Network, LLC on January 1, 2000. The Company is engaged in cellular telephone communications and paging services to residential and commercial customers located in eastern Kentucky. The Company's five members consist of Cellular Services, Inc.; Gearheart Communications Company, Inc.; Mountain Telecommunications, Inc.; Peoples Rural Telephone Cooperative Corporation, Inc.; and Thacker-Grigsby Telephone Co., Inc.

Cash

The Company maintains its cash balances, which exceed the \$100,000 federally insured limit, with several financial institutions. These financial institutions have strong credit ratings and management believes that credit risk related to the accounts is minimal.

Cash equivalents

For purposes of the statement of cash flows, the Company considers temporary investments having a maturity of three months or less to be cash equivalents.

Short-term investments

Certificates of deposit having original maturities between three and nine months are classified as short-term investments, are carried at cost, which approximates fair value, and are held to maturity.

Inventory

Inventory is composed of cellular telephone equipment, paging equipment, and accessories purchased for resale during the ordinary course of business. The inventory is valued at the lower of cost or market, cost being determined by the first-in, first-out (FIFO) method.

Property, plant and equipment

Property, plant and equipment are recorded at cost. Depreciation is provided using the straight-line method over the estimated useful lives of the assets.

Investment

The investment in affiliated company is composed of equity certificates in Rural Telephone Finance Cooperative and is reported at cost, which approximates fair value.

NOTES TO FINANCIAL STATEMENTS

Note 1. Summary of Significant Accounting Policies (Continued)

Intangible assets

The customer lists, non-compete agreements, FCC licenses, and use of name are recorded at cost and are being amortized over 15 years by the straight-line method. The excess cost over the fair value of the net assets acquired (goodwill) related to paging acquisitions is measured for impairment on an annual basis, and written down, if necessary, to its estimated value at that time. During the prior year, the Company expensed the remaining balance of goodwill as an impairment (see Note 8).

Recognition of revenue

Cellular service and paging revenues are recognized when earned. Monthly access and feature charges are billed one month in advance and recognized as revenue the following month. Revenue from telephone and accessories sold are recognized as revenue upon delivery to the customer.

Advertising

Advertising costs are expensed as incurred. At December 31, 2006 and 2005, these costs were \$1,574,298 and \$1,139,697, respectively.

Income taxes

Under existing provisions of the Internal Revenue Code, the income or loss of a limited liability company is recognized by the members for income tax purposes. Accordingly, no provision for federal income taxes has been provided for in the accompanying financial statements. Effective for years beginning on or after January 1, 2005, the State of Kentucky enacted legislation which now provides for the taxation of limited liability companies' at the entity level. The accompanying financial statements include the related state tax liability under the new regulations.

Use of estimates

Management uses estimates and assumptions in preparing financial statements. Those estimates and assumptions affect the reported amounts of assets and liabilities, the disclosure of contingent assets and liabilities, and the reported revenues and expenses.

NOTES TO FINANCIAL STATEMENTS

Note 2. Intangible Assets

Intangible assets consist of the following at December 31, 2006:

	<u>Gross Amount</u>	<u>Accumulated Amortization</u>
Customer lists	\$ 5,363,530	\$ (2,152,951)
Non-compete agreements	220,348	(121,577)
FCC licenses	1,141,593	(330,542)
Use of name	10,000	(4,334)
Other	408,474	(37,509)
	<u>\$ 7,143,945</u>	<u>\$ (2,646,913)</u>

Intangible assets consist of the following at December 31, 2005:

	<u>Gross Amount</u>	<u>Accumulated Amortization</u>
Customer lists	\$ 5,363,530	\$ (1,795,634)
Non-compete agreements	220,348	(106,898)
FCC licenses	1,141,593	(264,446)
Use of name	10,000	(3,668)
Other	68,038	(9,008)
	<u>\$ 6,803,509</u>	<u>\$ (2,179,654)</u>

Aggregate amortization expense related to these intangible assets for the years ended December 31, 2006 and 2005 totaled \$467,259 and \$437,982, respectively. The following represents the total estimated amortization of intangible assets for each of the succeeding five years:

Year ending December 31:

2006	\$ 450,000
2007	450,000
2008	450,000
2009	450,000
2010	450,000

NOTES TO FINANCIAL STATEMENTS

Note 3. Long-Term Debt

Long-term debt consists of the following at December 31:

	<u>2006</u>	<u>2005</u>
Note payable, Fifth Third Bank (a)		
Dated 02/28/06, variable rate (5.41% at 12/31/06)	\$ 14,200,000	\$ --
Notes payable, RTFC (b)		
Dated 11/13/97, variable rate		
Paid in full 03/01/06	--	194,957
Dated 11/13/97, variable rate		
Paid in full 03/01/06	--	899,406
Dated 11/13/97, fixed rate		
Paid in full 03/01/06	--	727,521
Dated 12/31/98, fixed rate		
Paid in full 03/01/06	--	618,521
Dated 02/13/01, variable rate		
Paid in full 03/01/06	--	786,457
Dated 02/13/01, variable rate		
Paid in full 03/01/06	--	932,200
Dated 07/27/01, variable rate		
Paid in full 03/01/06	--	2,845,311
Lines of Credit, RTFC		
Line of credit, variable rate (c)		
Paid in full 03/01/06	--	5,000,000
Line of credit, variable rate (d)		
Paid in full 03/01/06	--	1,750,000
Line of Credit, Fifth Third Bank (e)		
Due 03/28/08, variable rate (5.41% at 12/31/06)	--	--
	<u>\$ --</u>	<u>\$ 13,754,373</u>

(a) On February 28, 2006, the Company borrowed \$14,200,000 to restructure its debt. The note is payable in 10 annual installments of \$1,200,000 for 2007, \$1,400,000 for 2008 through 2012, and \$1,500,000 for 2013 through 2016, with a variable interest rate. The note is collateralized by the assets of the Company.

(b) The notes payable to Rural Telephone Finance Cooperative (RTFC) were secured by mortgage and security agreements that include substantially all of the assets of the Company. In addition, the Company was required to purchase equity certificates in RTFC equal to 5% of the total amounts borrowed. The notes were payable in quarterly installments over 15 years with interest at variable or fixed rates set by RTFC. The notes were paid in full on March 1, 2006.

NOTES TO FINANCIAL STATEMENTS

Note 3. Long-Term Debt (Continued)

- (c) The line of credit agreement with RTFC provided for borrowings up to \$5,000,000. The agreement carried an interest rate at prime, plus one and one-half percent, was unsecured and was renewed June 28, 2004 for 24 months. The line of credit was paid in full on March 1, 2006.
- (d) The line of credit agreement with RTFC provided for borrowings up to \$2,000,000. The agreement carried an interest rate at prime, plus one and one-half percent, was unsecured and due May 16, 2006. The line of credit was paid in full on March 1, 2006.
- (e) The line of credit agreement with Fifth Third Bank provides for borrowing up to \$3,000,000. The agreement carries a variable interest rate, is secured by certain assets of the company, and is due March 28, 2008.

Approximate maturities or payments required on principal under note payable agreements for each of the succeeding five years are as follows:

Year ending December 31:	
2006	\$ 1,200,000
2007	1,400,000
2008	1,400,000
2009	1,400,000
2010	1,400,000

Note 4. Retirement Plans

The Company has a 401(k) plan for qualifying employees who have reached twenty-one years of age. Eligible employees are allowed to invest up to 15% of their compensation and the Company has agreed to match 100% of the first 3% of the employees' contribution and 50% of the employees' contribution between 3% and 5%. The Company contributed \$73,607 and \$67,460 matching funds for its 401(k) plan during the years ended December 31, 2006 and 2005, respectively.

The Company also offers an employer sponsored retirement savings plan for qualified employees who have reached twenty-one years of age. The Company has agreed to contribute 9% of the eligible employee's compensation, plus an additional 5% of the original contribution.

The Company contributed \$259,859 and \$221,669 to its retirement savings plan during the years ended December 31, 2006 and 2005, respectively.

NOTES TO FINANCIAL STATEMENTS

Note 5. Related Party Transactions

The Company shares personnel with one of its members. The Company paid \$114,996 and \$132,681 for shared personnel during the years ended December 31, 2006 and 2005 respectively. The Company also leased offices and warehouse space from two members. The leases are for an unspecified length of time. The monthly lease payments total approximately \$7,000. In addition, the Company incurred interconnection and telephone charges from its members aggregating \$752,095 and \$786,283 for the years ended December 31, 2006 and 2005, respectively.

The Company leases two cellular tower sites from the officers and majority shareholders of a member for \$100 per month for each site. The leases are for an unspecified length of time. In addition, the Company leases two other sites from a company owned by this member for \$600 each on a month to month basis.

The Company leases cellular tower sites from the parent company of one of its other members for \$1,039 per month. The leases are for five years with options to renew.

The Company pays commissions to two of its members for phone sales to customers. The amount of commissions paid to related parties was \$45,484 and \$43,873 for 2006 and 2005 respectively.

Note 6. Operating Leases

The Company has entered into operating leases with its members and other customers to provide fiber optic transmission capacity and ancillary services. The terms of these leases are for 15 years.

Total rental income earned from these operating lease commitments included in the statements of income were \$1,130,809 and \$1,254,902 for the years ended December 31, 2006 and 2005, respectively. Rental income earned from the Company's members from these leases was \$631,789 and \$713,599 for the years ended December 31, 2006 and 2005, respectively.

Investments in operating leases are as follows at December 31:

	<u>2006</u>	<u>2005</u>
Fiber ring	\$ 6,471,128	\$ 6,245,412
Accumulated depreciation	<u>(982,379)</u>	<u>(773,028)</u>
	<u>\$ 5,488,749</u>	<u>\$ 5,472,384</u>

The future minimum rental payments expected to be received under these lease agreements for each of the succeeding five years are approximately \$700,000 each year based upon new contracts negotiated during 2005.

NOTES TO FINANCIAL STATEMENTS

Note 6. Operating Leases (Continued)

The Company has also entered into lease agreements with its members to obtain fiber optic transmission and digital microwave transmission services. The terms of these leases are for 15 years.

Rental expenses incurred under these operating lease commitments included in the statements of income were \$194,083 and \$33,329 for the years ended December 31, 2006 and 2005, respectively. The future minimum lease payments required under these lease agreements for each of the succeeding five years are \$115,734 each year.

Note 7. Eligible Telecommunication Carrier

During the prior year, the Company was granted Eligible Telecommunication Carrier (ETC) status by the Kentucky Public Service Commission. As an ETC, the Company receives funding from the federal Universal Service Fund (USF) to support the high cost of providing local telephone service in rural areas. USF payments amounted to \$3,716,602 and \$589,913 for 2006 and 2005 respectively.

Note 8. Impairment of Goodwill

During 2005, the Company completed its annual valuation of the acquired goodwill related to paging acquisitions. Pursuant to the valuation, the Company expensed the remaining balance of goodwill. In management's judgment, the underlying assets associated with the goodwill were determined to be of substantially less value than the amount originally paid. The Company disputed the amount based upon the estimated current market value of the purchased customer lists, which approximates the current amortized book value. Accordingly, the entire balance of the remaining note payable issued as part of the acquisitions, along with the related accrued interest, has been written off due to the impairment of goodwill.

The following is a summary of the impairment of goodwill expense included in the financial statements for the year ended December 31, 2005:

Goodwill	\$ 787,286
Note payable	(400,000)
Accrued interest	(56,000)
	<u>\$ 331,286</u>

DIRECTIONS TO THE BLACKKEY TOWER SITE

Beginning in front of the Letcher County Court House at Whitesburg , Kentucky go east on Main Street one block to the junction of North Webb Street.

Turn right on North Webb Street and go one tenth .1 mile to the junction of Ky Route 15.

Turn left on Ky Route 15 North and follow that road for 8.6 miles to the junction of Rout 7 South.

Turn left on Route 7 South and go 8.3 miles to the junction of Route 3408 (Elk Creek).

Turn right on Route 3408 and go 2.5 miles to the top of the mountain and the junction with Stewarts Road.

Turn left on Stewarts Road, (a gravel road), and go seven tenths, .7 miles to the tower site.

The total miles are 20.2.

Direction given by;

Dennis Shepherd
Thacker-Grigsby Telephone Co.
P O BOX 789
Hindman, Ky 41822
Phone; 606-785-2215
Cell Phone; 606-791-6263

Search Area Map

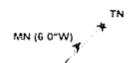
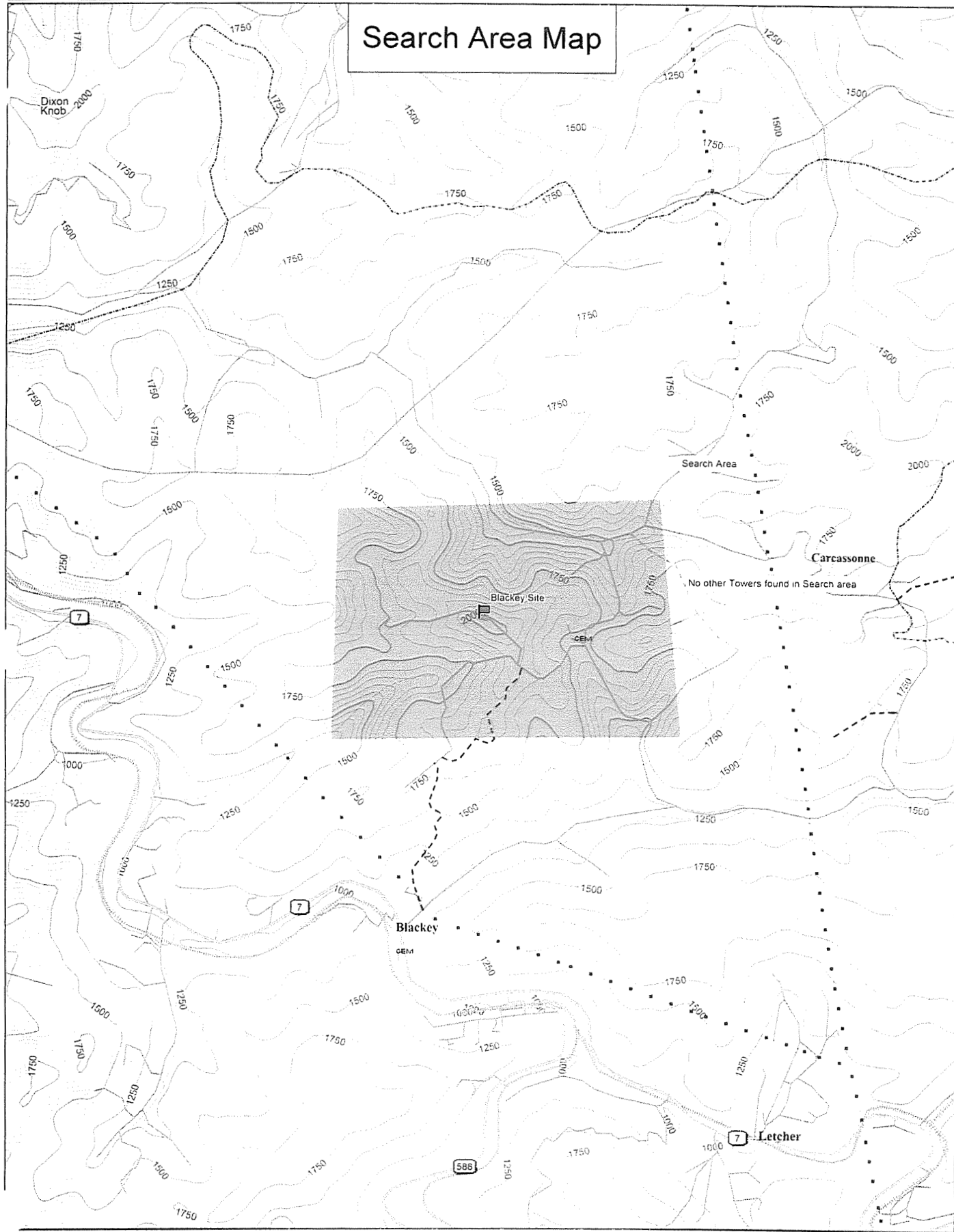

LEASE AGREEMENT

THIS LEASE is made and executed on the 7th day of June, 2007 by and between **Suzanne Whitaker Madden and Paxton Madden, her husband**, with a mailing address of Box 562 Hill Top Farm Rd ^{Blackey} Kentucky 41804; hereinafter referred to as "LESSORS", and **East Kentucky Network, LLC, d/b/a Appalachian Wireless**, 101 Technology Trail, Ivel, Kentucky 41642, hereinafter referred to as "LESSEE":

WITNESSETH:

That for and in consideration of the rents and other considerations hereinafter set out and subject to the terms and conditions therefore, Lessors do hereby lease, let and demise unto Lessee, its successors and assigns, to have and to hold for the term hereinafter set out and subject to the Lessee's right to surrender or terminate this Lease and provided hereinafter, the following described premises ("Leased Premises"), which term shall include all real property, rights and privileges herein granted:

BEING a part of the same property conveyed to Lessors by a Deed of Conveyance from Charlie L. Whitaker and Joyce Whitaker, his wife, to Suzanne Whitaker Madden dated July 2, 2004 of record in Deed Book 372, Page 605, Letcher County Clerk's Office.

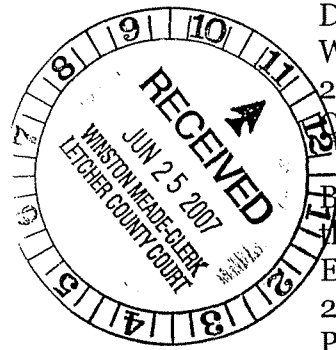

BEING the same property described by metes and bounds in the description attached hereto and made a part hereof as Exhibit "A", and as shown on the plat dated 26 day of May, 2007, prepared by Randall L. Coleman, Licensed Professional Land Surveyor, and attached hereto and made a part hereof as Exhibit "B."

The Lessors grant unto Lessee full and complete right of ingress, egress and regress over roads located upon this property controlled by Lessors to and from the Leased Premises, and the non-exclusive right to use any existing road located on this property. In the event the Lessee desires to relocate all or any portion of an existing roadway or to

construct another access road to the Leased Premises, the location of such roadway shall be mutually agreed upon by Lessors and Lessee. Lessors further grant to the Lessee a right of way and easement to construct and maintain and operate telephone and power transmission lines over Lessor's remaining property to the Leased Premises for service of the tower and related facilities only, said lines to be located where feasible along the access road to the Leased Premises, with Lessors having input as to location of said power transmission lines in the event Lessee changes the location of its access road. Lessee shall have the right to trim or remove trees, limbs or underbrush which interferes with its access road or power/telephone lines wherever such road and lines are located. Lessee shall help maintain the existing road with gravel and any needed repairs.

This Lease is made on the following terms and conditions:

1. TERM OF LEASE. The term of this lease shall be for a period of twenty-five (25) years from and after the date hereof (the "Initial Term"), with the exclusive option of Lessee to extend the Leasehold period for an additional term of twenty-five (25) years (the "Additional Term"). In the event that Lessee desires to extend this Lease Agreement, it shall give Lessors notice of such intention in writing at least six (6) months before expiration of the Initial Term.

2. CANCELLATION. Lessee shall have the right to terminate this Lease and abandon the Premises at any time under its sole discretion, upon six (6) month written notice to Lessors' of its intention to do so. In the event of termination by Lessee, the Lessors shall have no obligation to refund all or any portion of the annual Leasehold rental payment that has been paid. Upon termination of this Lease, Lessee shall have one hundred eight (180) days thereafter to remove all structures it has erected upon the Leased Premises,

and to reclaim the premises. Payment shall continue until said structures are removed.

3. RENTAL - INITIAL LEASE TERM. As rental for the Leased Premises, Lessee shall pay to Lessors annually and in advance the sum of Six Thousand Dollars (\$6,000.00) per annum beginning with the date of execution of this Lease Agreement by the parties, with the same sum being due and payable thereafter on each anniversary date that this Lease Agreement is in effect through and including the first ^{D.S. Twenty Five SWM} ~~five (5)~~ years of the Initial Term of this Lease Agreement.

4. RENTAL - ADDITIONAL TERM. In the event this Lease Agreement is extended for an additional term of twenty-five (25) years, the annual rental in the sum of Six Thousand Dollars (\$6,000.00) will be due and payable per annum on each anniversary date that this Lease Agreement is in effect.

5. USE OF PREMISES. Lessee shall have the exclusive rights and privileges of the use of the Leased Premises for the purpose of constructing buildings, towers, and other related facilities, including, but not limited to telephone lines, coaxial lines, power lines and the installation of any and all other equipment deemed necessary by Lessee to receive and transmit any and all electronic signals in the rural service area now or hereafter to be served by the facility. The parties hereto recognize that technology in the communications field is advancing at a rapid rate and that this site may be used for any other purpose now in the development stage or which may later be developed in the communications industry to carry out the objectives of Lessee, that being to transmit and receive signals and communications by wire, fiber optics, radio and satellite. Lessee shall not use the Leased Premises for purposes other than maintenance or use as a site for communications by the use of methods now or hereafter known.

Lessee shall gate its access road in a manner to best prevent trespassing. The gate shall be kept locked with a lock furnished by Lessee, who shall also furnish the Lessors with a key to the lock. Lessee shall not allow any persons not associated with its business to have access to the Leased Premises or its access road. Lessees shall have the right to relocate the road to the site at Lessee's expense, at a mutually agreed upon route, so as long as Lessors have the right to use the new road, which use by Lessors shall not interfere with Lessee's use thereof or pose a threat to the security of Lessee's operations or the Leased Premises.

Lessee agrees to maintain the Leased Premises in a neat and orderly manner.

6. INDEMNITY. Lessee agrees to indemnify and save harmless the Lessors from any liability by virtue of Lessee's activities upon the Leased Premises or in the exercise of any rights and privileges granted herein, specifically including but not limited to any claim, loss, fine, penalty and costs (including reasonable attorney's fees) arising out of any violation of any environmental laws or regulations. This provision shall survive the termination of the lease. Lessee shall maintain and keep in full force and effect public liability and property damage insurance in an amount of at least One Million Dollars (\$1,000,000.00). Lessors shall not be held liable for personal injury or property damage on the Leased Premises whether or not associated with Lessee.

7. MISCELLANEOUS PROVISIONS. Lessee shall keep and maintain the Leased Premises and keep the site clear and free of litter.

8. NOTICES. All notices, demands, or other writings in this Lease Agreement provided to be given, made or sent, or which may be given or made or sent, to either party hereto to the other, shall be deemed to have been fully given or made or sent when made in writing and deposited in the United States Mail, certified and postage prepaid, to Lessors

and Lessee at the addresses stated in the caption of this Lease Agreement. Such addresses may be changed by written notice given by such party as above provided.

9. SUCCESSORS AND ASSIGNS. This Lease Agreement shall be binding upon the parties hereto, their heirs, executors, administrators and assigns.

WITNESS OUR HANDS, the day and year aforesaid.

LESSORS:

Suzanne Whitaker Madden
Suzanne Whitaker Madden

Paxton Madden
Paxton Madden

LESSEE:

**EAST KENTUCKY NETWORK, LLC
d/b/a APPALACHIAN WIRELESS**

BY: Dwight F. Robinson

ITS: GENERAL MANAGER

**STATE OF KENTUCKY
COUNTY OF LETCHER**

The foregoing Lease Agreement was this 7th day of June, 2007, produced and acknowledged before me by **Suzanne Whitaker Madden and Paxton Madden**, Lessors.

Dennis Shepherd
NOTARY PUBLIC
COMMISSION EXPIRES: Oct. 22 - 2009

STATE OF KENTUCKY
COUNTY OF Floyd

The foregoing Lease Agreement was this 12th day of June, 2007,
produced and acknowledged before me by **East Kentucky Network, LLC, dba
Appalachian Wireless** by Gerald F Robinette, its General Manager,
Lessee.

Dennis Shepherd
NOTARY PUBLIC
COMMISSION EXPIRES: Oct: 22-2009

This is to certify that this
instrument was prepared by:

William S. Kendrick
WILLIAM S. KENDRICK, ATTORNEY
FRANCIS, KENDRICK & FRANCIS
P.O. Box 268
Prestonsburg, Kentucky 41653
606/886-2812

STATE OF KENTUCKY
COUNTY OF LETCHER

**Clerk's Certificate of
Lodgment and Record**

I, Winston Meade, Clerk of the County for the County and
State aforesaid, certify that the foregoing Lease Agreement was on the 25 day of
June, 2007 lodged for record, whereupon the same, with the foregoing and
this certificate have been duly recorded in my office. In lease book 54 page 531

WITNESS my hand, this 25 day of June, 2007.

Winston Meade Clerk
By Angie Back D.C.

Suzanne Madden

LOT #1

Lying and being in Letcher County near Blackey, Ky. on Orchard Branch of the North Fork of the Kentucky River and bounded as follows:

Beginning on a found metal fence post on the center of the ridge between Bull Creek and Orchard Branch, said point being the northeast corner of the Suzanne Madden tract and also a corner to Charlie Whitaker and Elkhorn-Hazard Land Corporation, thence with said Whitaker's line down the hill, SE $20^{\circ}59'22''$, 110.01' to a found metal fence post, thence leaving said Whitaker's line and around the side of the hill SW $74^{\circ}28'13''$, 187.69' to a #4 rebar (set/cap#2437), thence up the hill NW $48^{\circ}17'32''$, 42.36' to a #4 rebar (set/cap#2437) on the north edge of the private road, thence NE $04^{\circ}49'09''$, 68.51' to a #4 rebar (set/cap#2437) on the center of the ridge and the line of Elkhorn-Hazard Coal Land Corporation, thence with said Corporation's line and the center of the ridge NE $82^{\circ}35'00''$, 73.48' to a #4 rebar (set/cap#2437), thence NE $68^{\circ}23'37''$, 51.37' to a #4 rebar (set/cap#2437), thence NE $58^{\circ}56'24''$, 54.48' to the beginning containing 0.43 acres.

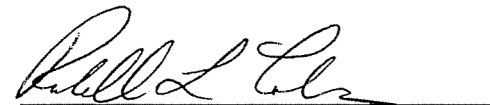
 5/26/07
Randall L. Coleman PLS #2437 Date

"Exhibit A"

SITE SURVEY
STRUCTURE LOCATION

BLACKKEY IN LETCHER CO

APPALACHIAN WIRELESS
101 TECHNOLOGY TRAIL
IVEL, KY. 41642
PROPOSED TOWER SITE
BLACKKEY IN LETCHER CO KY

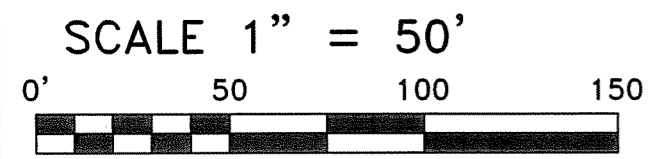
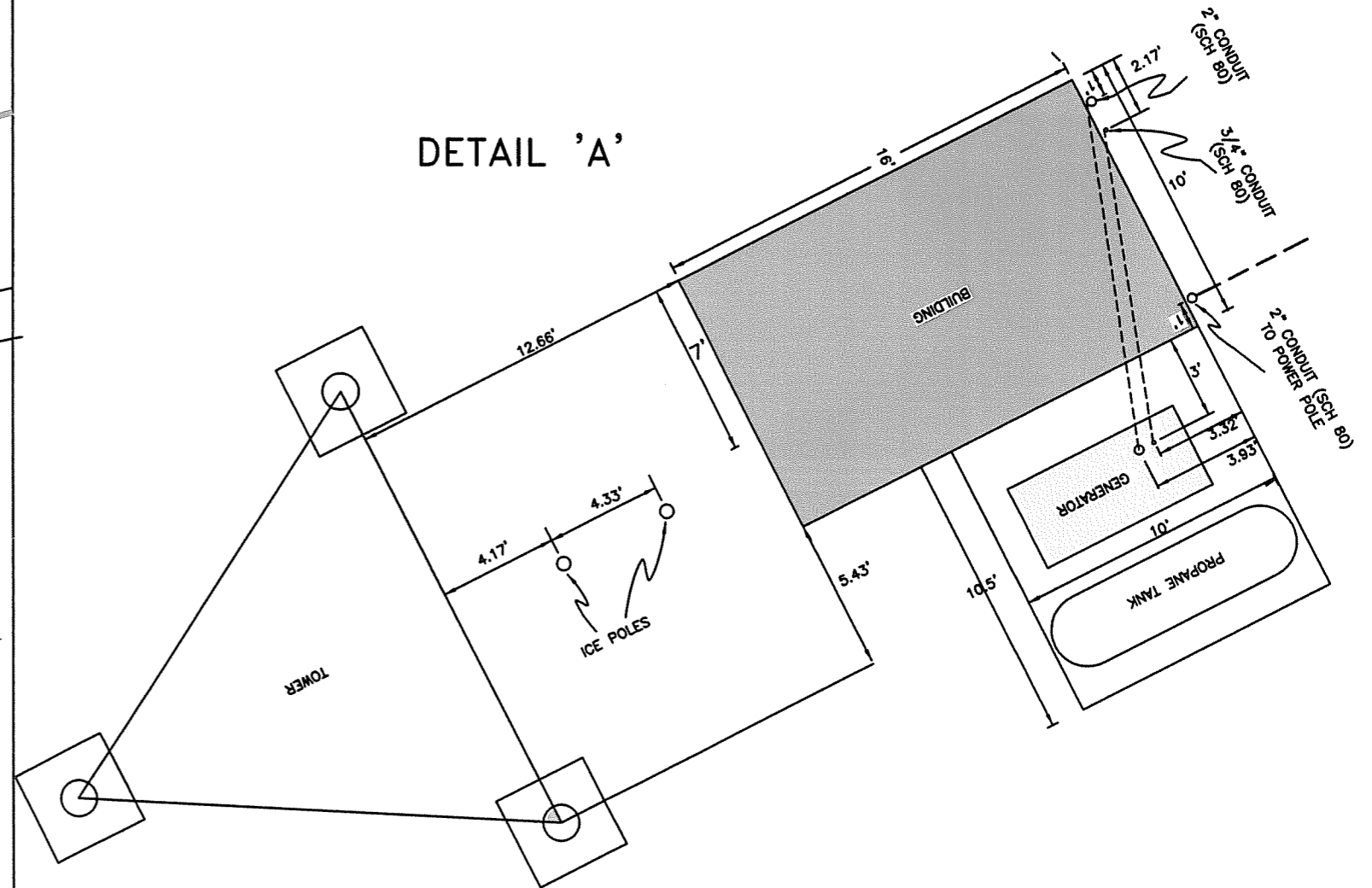
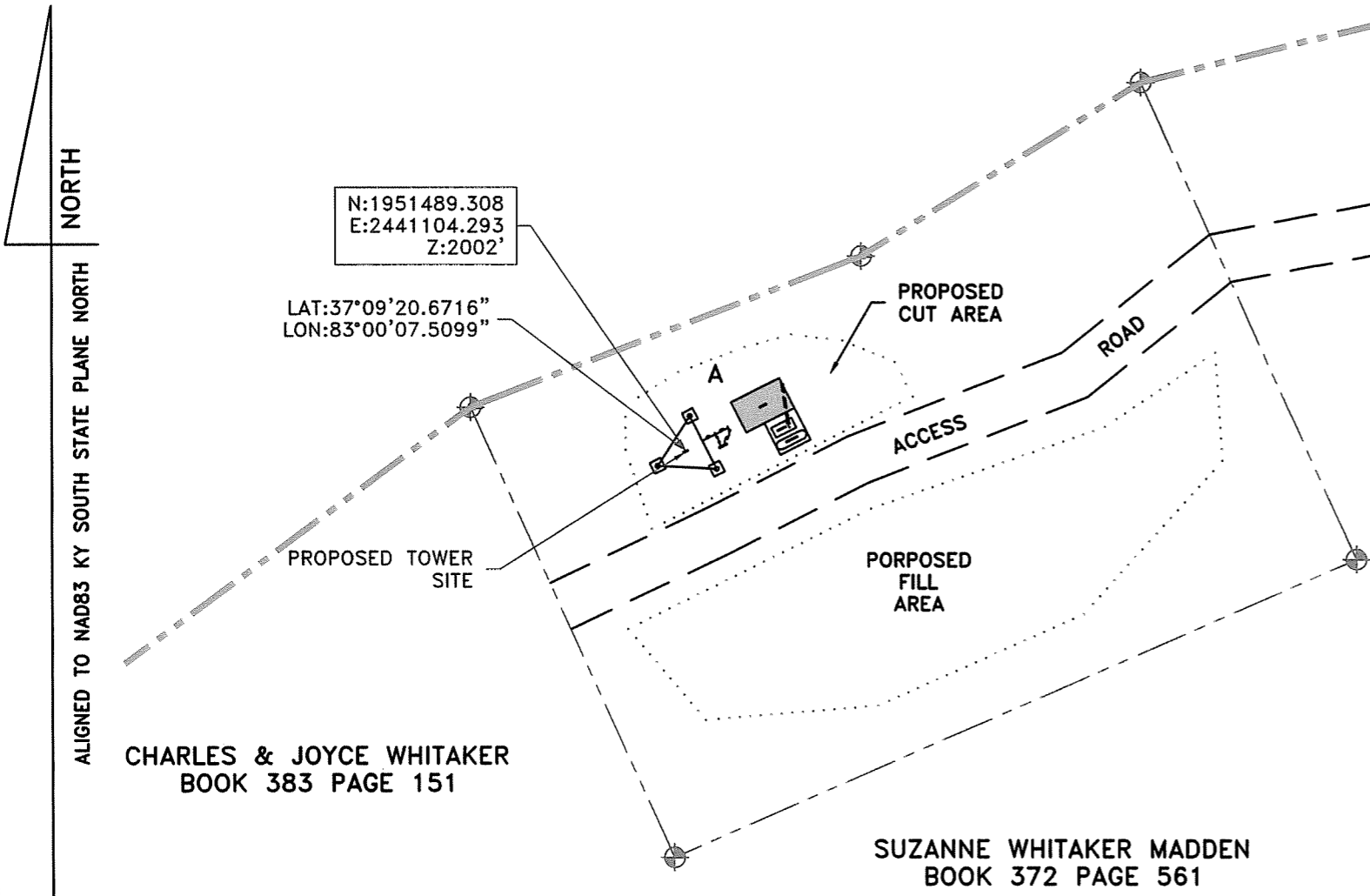

LEGEND

SURVEY STA	FOUND	SET
IRON PIN WITH CAP (18" X .5" REBAR PLASTIC CAP MARKED LS2259)	⊕	⊕
BOUNDARY LINE	- - - - -	
ACCESS ROAD	= = = = =	
PARENT TRACT LINE	- - - - -	

02/24/08

-THE PROPOSED TOWER HAS BEEN LOCATED USING DUAL FREQUENCY GPS UNIT PROCESSED BY "OPUS"
 -STATE PLANE COORDINATES NAD 83 KY SOUTH ZONE N 1951489.31, E 2441104.29, EL 2002 FT MSL
 -PRECISION: HORIZONTAL=0.30' VERTICAL=0.50'
 -PROPERTY LINE INFORMATION TAKEN FROM DEEDS AND VERIFIED IN THE FIELD.

James W. Caudill 12305 2-24-08
 JAMES W. CAUDILL P.E. DATE

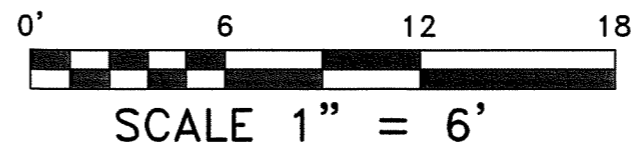
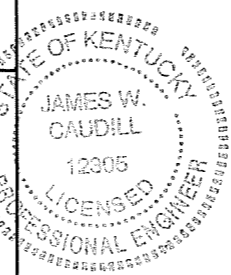

NOTE: * USE SWEEPS IN CONDUIT FOR ALL TURNS
 * CONDUITS SHALL BE PLACED 3.25" OUTSIDE CONCRETE SLAB

SITE SURVEY/STR LOCATION

COLEMAN
ENGINEERING

P.O. BOX 153, HINDMAN, KY 41822

