

RECEIVED

DEC 05 2007

PUBLIC SERVICE
COMMISSION

EAST KENTUCKY NETWORK

d/b/a

APPALACHIAN WIRELESS

WRIGLEY CELLULAR TOWER APPLICATION

Morgan County

P.S.C. CASE # 2007- 00486

RECEIVED

DEC 05 2007

COMMONWEALTH OF KENTUCKY
BEFORE THE PUBLIC SERVICE COMMISSION

PUBLIC SERVICE
COMMISSION

In the matter of:

THE APPLICATION OF EAST KENTUCKY NETWORK)
LIMITED LIABILITY COMPANY FOR THE ISSUANCE)
OF A CERTIFICATE OF PUBLIC CONVENIENCE AND) CASE No 2007-00486
NECESSITY TO CONSTRUCT A TOWER IN MORGAN)
COUNTY, KENTUCKY).

In case number 91-002 East Kentucky Network, LLC, formerly Mountaineer Cellular Limited Liability Company was granted a Certificate of Public Convenience and Necessity by the Kentucky Public Service Commission to construct and operate a cellular radio telecommunications system for KY RSA 10.

In an effort to improve service in Morgan County, East Kentucky Network, LLC pursuant to KRS 278.020 Subsection 1 and 807 KAR 5:001 Section 9 is seeking the Commission's approval to construct a tower near Wrigley. The proposed tower will be a 300 foot self-supporting tower located on a ridge between Road Fork and North Fork, both are tributaries of the Licking River, approximately one mile north of the community of Redwine (38° 01' 53.9" N 83° 13' 34.4 W). A map and detailed directions to the site can be found in Exhibit 8.

East Kentucky Network LLC merger documents were filed with the Commission on February 2, 2001 in Case # 2001-022.

FAA and Kentucky Airport Zoning Commission approvals have been applied for and a copy of the application is included as Exhibit 4 and 6.

No Federal Communications Commission approval is required prior to construction of this facility. Once service is established from this tower we must immediately notify the Federal Communications Commission of its operation. Prior approval is needed only if the proposed

facility increases the size of the cellular geographic service area. This cell site will not expand the cellular geographic service area.

A geologist was employed to determine soil and rock types and to ascertain the distance to solid bedrock. The geotechnical report is enclosed as Exhibit 3

A copy of the tower design information is enclosed as Exhibit 5. The proposed tower has been designed by engineers at Allstate Tower, Inc and will be constructed under their supervision. Their qualifications are evidenced in Exhibit 5 by the seal and signature of the registered professional engineer responsible for this project.

The tower will be erected by A & D Communication of Cattlesburg, Kentucky. A & D has vast experience in the erection of communications towers.

Enclosed, and should be filed with Exhibit 10 is a survey of the proposed tower site signed by a Kentucky registered professional engineer. There is no structure within 500 feet of the proposed tower as indicated in this enclosure. Exhibit 2 is a list of all Property owners or residents according to the property valuation administrator's record who reside or own property within 500 feet of the proposed tower in accordance with the Public Valuation Administrator'. No other properties are contiguous with East Kentucky's property.

Exhibit 12, back of folder, contains a vertical sketch of the tower supplied by Coleman Engineering.

Pursuant to 807 KAR5:063 Sections 1(1)(L) and Section 1(1)(n)(1) all affected property owners according to the property valuation administrator's record who reside or own property within 500 feet of the proposed Tower were notified by certified mail return receipt requested of East Kentucky Network, LLC's proposed construction and informed of their right to intervene. They were given the docket number under which this application is filed. Enclosed in Exhibit 2 is a copy of that notification.

Morgan County has no formal local planning unit. In absence of this unit the Morgan County Judge Executive's office was notified by certified mail, return receipt requested of East Kentucky Network Limited Liability Company's proposal and informed of their right to intervene. They were given the docket number under which this application is filed. Enclosed in Exhibit 1 is a copy of that notification.

East Kentucky Network, LLC will finance the subject Construction with earned surplus in its General Fund.

Estimated Cost of Construction	140,000.00
Annual Operation Expense of Tower	12,500.00

Two notice signs meeting the requirements prescribed by 807 KAR 5:063, Section 1(2), measuring at least two (2) feet in height and four (4) feet in width and containing all required language in letters of required height, have been posted, one at a visible location on the proposed site and one on the nearest public road. The two signs were posted on November 30, 2007 and will remain posted for at least two weeks after filing of this application as specified.

Enclosed in Exhibit 9 is a copy of East Kentucky Network LLC's deeds to the site.

Notice of the location of the proposed construction was published on the first two weeks of November in the Licking Valley Courier. Enclosed is a copy of that notice in Exhibit 1. The Licking Valley Courier is the newspaper with the largest circulation in Morgan County.

The proposed construction site is on a very rugged mountaintop some feet from the nearest structure. Prior to construction the site was wooded.

Due to the steep hillside surrounding the proposed site, the property in close proximity is unsuitable for any type of development. East Kentucky Network LLC's operation will not affect the use of nearby land nor its value. No more suitable site exists in the area. A copy of the search area map is enclosed in Exhibit 8. No other tower capable of supporting East Kentucky Network LLC's load exists in the general area; therefore, there is no opportunity for co-location of our facilities with anyone else.

WHEREFORE, Applicant respectfully requests that the PSC accept the foregoing Application for filing, and having met the requirements of KRS [278.020(1), 278.650, and 278.665] and all applicable rules and regulations of the PSC, grant a Certificate of Public Convenience and Necessity to construct and operate the proposed tower.

The foregoing document was prepared by Janice Robinson, Technical Site Coordinator for East Kentucky Network d/b/a Appalachian Wireless. All related questions or correspondence concerning this filing should be mailed to East Kentucky Network, LLC d/b/a Appalachian Wireless, 101 Technology Trail, Ivel, KY 41642.

SUBMITTED BY: Janice Robinson DATE: 12-3-07
Janice Robinson, Cell Site Coordinator

APPROVED BY: Gerald F. Robinette DATE: 12-4-07
Gerald Robinette, General Manager

Contacts:

Gerald Robinette, General Manager

Phone: (606) 791-2375, Ext. 111

Email: grobinette110@ekn.com

Janice Robinson, Technical Site Coordinator

Phone: (606) 791-2375, Ext. 166

Email: jrobinson166a@ekn.com

Mailing Address:

**East Kentucky Network, LLC.
d/b/a Appalachian Wireless
101 Technology Trail
Ivel, KY 41642**

1	Notification/Response from County.
2	Copies of Cell Site Notices.
3	Universal Letter of Soil Bearing Analysis.
4	Kentucky Airport Zoning Commission Application.
5	Tower Design.
6	FAA Approval/Notice of Proposed Construction.
7	Audited Financial Statements
8	Driving Directions and Map to Suitable Scale.
9	Deed/Lease Agreement for Proposed Site.
10	Survey of Site Signed/Sealed by Professional Engineer Registered in State of Kentucky.
11	Site Survey Map with Property Owners identified in Accordance with PVA of County.
12	Vertical Profile Sketch of Proposed Tower.

EAST KENTUCKY NETWORK
101 TECHNOLOGY TRAIL
IVEL, KY 41642
PHONE: (606) 874-7550
FAX: (606) 874-7551
EMAIL: INFO@EKN.COM
WEBSITE: WWW.EKN.COM



VIA: U.S. CERTIFIED MAIL

December 3, 2007

Tim Conley, Judge/Executive
Morgan County Courthouse
450 Prestonsburg Street
West Liberty, KY 41472

RE: Public Notice-Public Service Commission of Kentucky (Case No. 2007-00486)

East Kentucky Network, LLC d/b/a Appalachian Wireless has applied to the Public Service Commission of Kentucky for a Certificate of Public Convenience and Necessity to construct and operate a new facility to provide cellular telecommunications service. The facility will include a 300 foot self-supporting tower with attached antennas extending upwards, and an equipment shelter located on a ridge near Wrigley approximately one mile north of the community of Redwine (38° 01' 53.9" N 83° 13' 34.4 W). A map showing the location of the proposed new facility is enclosed. This notice is being sent to you because you are the County Judge Executive of Morgan County.

The Commission invites your comments regarding the proposed construction. You also have the right to intervene in this matter. The Commission must receive your initial communication within 20 days of the date of this letter as shown above.

Your comments and request for intervention should be addressed to: Executive Director's Office, Public Service Commission of Kentucky, P.O. Box 615, Frankfort, KY 40602. Please refer to Case No. 2007-00486 in your correspondence.

Sincerely,

A handwritten signature in cursive script that reads "Janice Robinson".

Janice Robinson
Technical Site Coordinator
enclosure

Location Map

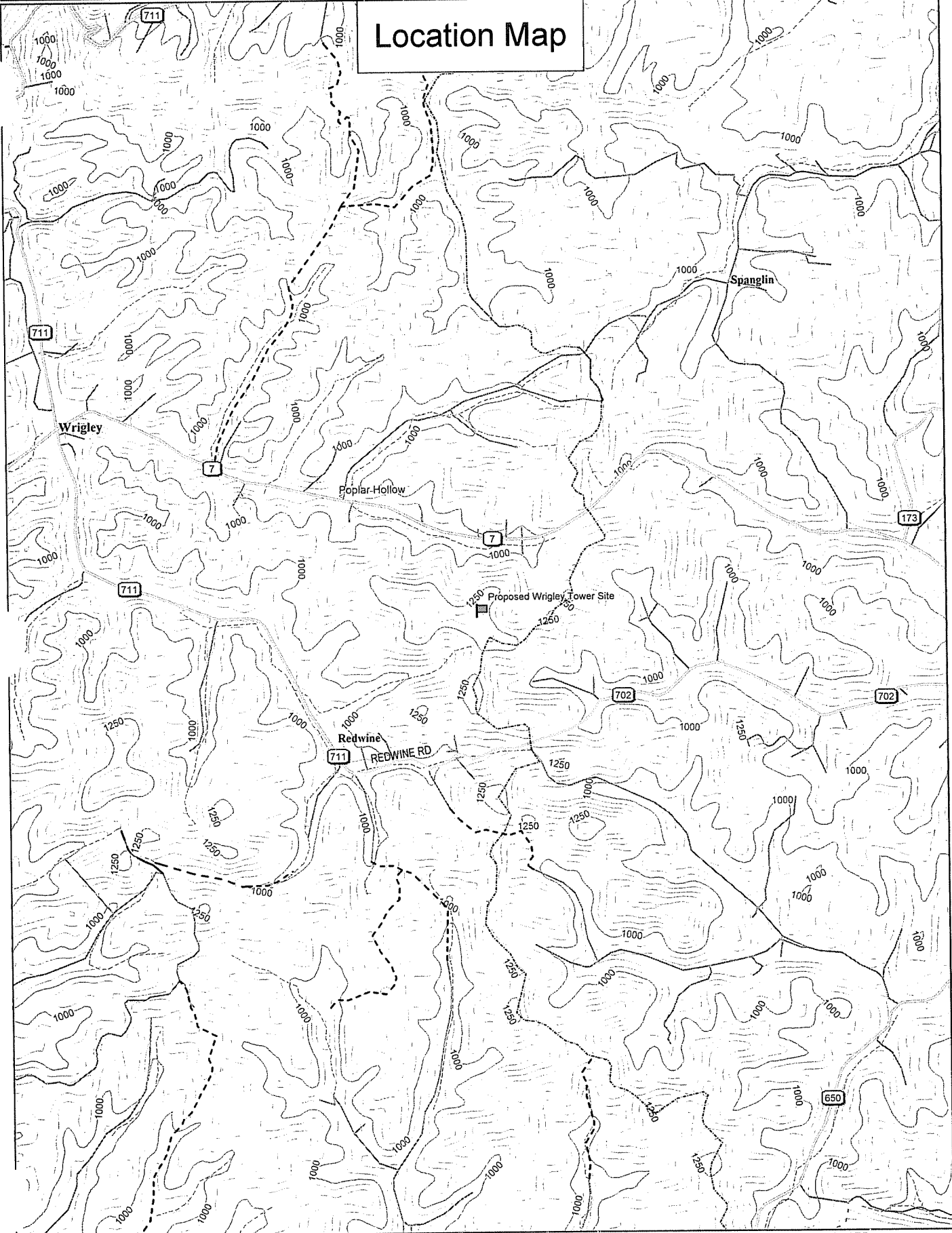

Data use subject to license.
© 2004 DeLorme. Topo USA® 5.0.
www.delorme.com

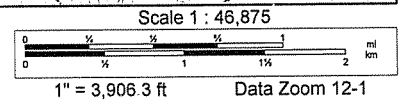
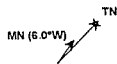

* East Kentucky Network, LLC
d/b/a Appalachian Wireless
101 Technology Trail
Ivel, KY 41642

Phone: 606/874-7550
Fax: 606/791-2225

EAST KENTUCKY
NETWORK



Fax

To: The Licking Valley Courier	From: JANICE ROBINSON
ATT: Public Notice Advertising	Accounting Department
Fax: 606-743-3565	Phone: 606-874-7550, Ext.166
Phone: 606-743-3551	Pages: <input type="text" value="1"/> Pages (INCLUDING COVER)
Re: PUBLIC NOTICE ADVERTISEMENT	Date: November 30, 2007

We would like to have the following public notice printed in The Licking Valley Courier for the next two weeks.

The notice should state the following:

PUBLIC NOTICE:

RE: Public Service Commission of Kentucky (CASE NO. 2007-00486)

Notice is hereby given that East Kentucky Network, LLC, dba Appalachian Wireless has applied to the Kentucky Public Service Commission to construct a tower located on a ridge near Wrigley one mile north of the community of Redwine (38° 01' 53.9" N 83° 13' 34.4 W. The proposed tower will be a 300 foot self-supporting tower with attached antennas extending upwards and an equipment shelter.

If you would like to respond to this notice, please contact the Executive Director, Public Service Commission, 211 Sower Boulevard, P o Box 615, Frankfort, Kentucky 40602. Please refer to Case No. 2007-00486.

If you have questions about the placement of the above mentioned notice, please call me at 606-791-2375, ext. 166.

Thank you, Janice Robinson

Accounting Department If you have any problems with this fax, please call 606/886-6007. The message above and the information contained in the documents transmitted are confidential and intended only for the person(s) named above. Dissemination, distribution or copying of this communication by anyone other than the person(s) named above is prohibited. If you have received this communication in error, please notify us immediately by telephone and return the original message to us at the address listed above via regular mail. Thank you.

Next Generation Communications

* * * Communication Result Report (Dec. 3. 2007 12:14PM) * * *

1) E k n
2)

e/Time: Dec. 3. 2007 12:13PM

File No. Mode	Destination	Pg(s)	Result	Page Not Sent
0487 Memory TX	6067433565	P. 1	OK	

Reason for error
 E. 1) Hang up or line fail
 E. 2) Busy
 E. 3) No answer
 E. 4) No facsimile connection
 E. 5) Exceeded max. E-mail size

* East Kentucky Network, LLC
 dba Appalachian Wireless
 101 Technology Trail
 Irvy, KY 41642
 Phone: 606/874-7550
 Fax: 606/791-2225



Fax

To: The Licking Valley Courier From: JANICE ROBINSON
 ATT: Public Notice Advertising Accounting Department
 Fax: 606-743-3565 Phone: 606-874-7550, Ext.108
 Pages: 1 Pages (INCLUDING COVER)
 Ref: PUBLIC NOTICE ADVERTISEMENT Date: November 30, 2007

We would like to have the following public notice printed in The Licking Valley Courier for the next two weeks.

The notice should state the following:

PUBLIC NOTICE:
 RE: Public Service Commission of Kentucky (CASE NO. 2007-00486)
 Notice is hereby given that East Kentucky Network, LLC, dba Appalachian Wireless has applied to the Kentucky Public Service Commission to construct a tower located on a ridge near Wrigley one mile north of the community of Redwine (38° 01' 53.9" N 83° 13' 34.4 W. The proposed tower will be a 300 foot self-supporting tower with attached antennas extending upwards and an equipment shelter.
 If you would like to respond to this notice, please contact the Executive Director, Public Service Commission, 211 Sower Boulevard, P o Box 615, Frankfort, Kentucky 40602. Please refer to Case No. 2007-00486.

If you have questions about the placement of the above mentioned notice, please call me at 606-791-2375, ext. 166.

Thank you, Janice Robinson

Accounting Department If you have any problems with this fax, please call 606/888-6007. The message above and the information contained in the documents transmitted are confidential and intended only for the person(s) named above. Dissemination, distribution or copying of this communication by anyone other than the person(s) named above is prohibited. If you have received this communication in error, please notify us immediately by telephone and return the original message to us at the address listed above via regular mail. Thank you.

EXHIBIT II : LIST OF PROPERTY OWNERS:

WRIGLEY SITE, MORGAN COUNTY, KENTUCKY
Statement Pursuant to Section 1 (1) (I) 807 KAR 5:063

Section 1 (1)(I) 1. The following is a list of every property owner who according to property valuation administrator's records, owns property within 500 feet of the proposed tower and each have been: notified by certified mail, return receipt requested, of the proposed construction.,

Section 1 (1) I 2. Every person listed below who, according to the property valuation administrator's records, owns property within 500 feet of the proposed tower has been: Given the Commission docket number under which the application will be processed: and

Section 1 (1) I 3. Every person listed below who, according to property valuation administrator's records, owns property within 500 feet of the proposed tower has been: Informed of his right to request intervention.

LIST OF PROPERTY OWNERS

Emory Cecil Smith
12154 HWY 7
West Liberty, KY 41472

Maurice Newsome
Box 2195
Pikeville, KY 41501

Mike Ross, Inc. & ETAL
c/o Trio Petroleum Corp.
P. O. Box 880
Glennville, WV 26351

Gary Bishop
11808 HWY 7
West Liberty, KY 41472

Elton & Brenda Oneal
11808 HWY 7
West Liberty, KY 41472

Danny Ray & Kathy Fannin
51 Wells Hill Lane
West Liberty, KY 41472

David Allen
11807 HWY 7
West Liberty, KY 41472

Gerry Nell Allen
11803 HWY 7
West Liberty, KY 41472

Edna Blankenship
9487 HWY 711
West Liberty, KY 41472

EAST KENTUCKY NETWORK
101 TECHNOLOGY TRAIL
IVEL, KY 41642
PHONE: (606) 874-7550
FAX: (606) 874-7551
INFO@EKN.COM
WWW.EKN.COM



VIA: U.S. CERTIFIED MAIL

(CASE NO. 2007-00486)

PUBLIC NOTICE

December 3, 2007

Edna Blankenship
9487 HWY 711
West Liberty, KY 41472

RE: Public Notice-Public Service Commission of Kentucky (Case No. 2007-00486)

East Kentucky Network, LLC d/b/a Appalachian Wireless has applied to the Public Service Commission of Kentucky for a Certificate of Public Convenience and Necessity to construct and operate a new facility to provide cellular telecommunications service. The proposed tower will be a 300 foot self-supporting tower with attached antennas extending upwards, and an equipment shelter located on a ridge near Wrigley approximately one mile north of the community of Redwine (38° 01' 53.9" N 83° 13' 34.4 W). A map showing the location of the proposed new facility is enclosed. This notice is being sent to you because you may own property or reside within a 500' radius of the proposed tower.

The Commission invites your comments regarding the proposed construction. You also have the right to intervene in this matter. The Commission must receive your initial communication within 20 days of **the date** of this letter as shown **above**.

Your comments and request for intervention should be addressed to: Executive Director's Office, Public Service Commission of Kentucky, P.O. Box 615, Frankfort, KY 40602. Please refer to Case No. 2007-00486 in your correspondence.

Sincerely,

Janice Robinson
Technical Site Coordinator
Enclosure 1

EAST KENTUCKY NETWORK
101 TECHNOLOGY TRAIL
LIBERTY, KY 41642
PHONE: (606) 874-7550
FAX: (606) 874-7551
EMAIL: INFO@EKN.COM
WEBSITE: WWW.EKN.COM

EAST KENTUCKY
NETWORK



VIA: U.S. CERTIFIED MAIL

(CASE NO. 2007-00486)

PUBLIC NOTICE

December 3, 2007

Gerry Nell Allen
11807 HWY 7
West Liberty, KY 41472

RE: Public Notice-Public Service Commission of Kentucky (Case No. 2007-00486)

East Kentucky Network, LLC d/b/a Appalachian Wireless has applied to the Public Service Commission of Kentucky for a Certificate of Public Convenience and Necessity to construct and operate a new facility to provide cellular telecommunications service. The proposed tower will be a 300 foot self-supporting tower with attached antennas extending upwards, and an equipment shelter located on a ridge near Wrigley approximately one mile north of the community of Redwine (38° 01' 53.9" N 83° 13' 34.4 W). A map showing the location of the proposed new facility is enclosed. This notice is being sent to you because you may own property or reside within a 500' radius of the proposed tower.

The Commission invites your comments regarding the proposed construction. You also have the right to intervene in this matter. The Commission must receive your initial communication within 20 days of the date of this letter as shown above.

Your comments and request for intervention **should** be addressed to: Executive Director's Office, Public Service Commission of Kentucky, P.O. Box 615, Frankfort, KY 40602. Please refer to Case No. 2007-00486 in your correspondence.

Sincerely,

Janice Robinson
Technical Site Coordinator
Enclosure 1

EAST KENTUCKY NETWORK
101 TECHNOLOGY TRAIL
LEVEL, KY 41642
PHONE: (606) 874-7550
FAX: (606) 874-7551
EMAIL: INFO@EKN.COM
WWW: WWW.EKN.COM

EAST KENTUCKY
NETWORK



VIA: U.S. CERTIFIED MAIL

(CASE NO. 2007-00486)

PUBLIC NOTICE

December 3, 2007

David Allen
11807 HWY 7
West Liberty, KY 41472

RE: Public Notice-Public Service Commission of Kentucky (Case No. 2007-00486)

East Kentucky Network, LLC d/b/a Appalachian Wireless has applied to the Public Service Commission of Kentucky for a Certificate of Public Convenience and Necessity to construct and operate a new facility to provide cellular telecommunications service. The proposed tower will be a 300 foot self-supporting tower with attached antennas extending upwards, and an equipment shelter located on a ridge near Wrigley approximately one mile north of the community of Redwine (38° 01' 53.9" N 83° 13' 34.4 W). A map showing the location of the proposed new facility is enclosed. This notice is being sent to you because you may own property or reside within a 500' radius of the proposed tower.

The Commission invites your comments regarding the proposed construction. You also have the right to **intervene** in this matter. **The Commission must receive your initial communication within 20 days of the date of this letter as shown above.**

Your comments and request for intervention should be addressed to: Executive Director's Office, Public Service Commission of Kentucky, P.O. Box 615, Frankfort, KY 40602. Please refer to Case No. 2007-00486 in your correspondence.

Sincerely,

A handwritten signature in cursive script that reads "Janice Robinson". The ink is dark and the signature is fluid and legible.

Janice Robinson
Technical Site Coordinator
Enclosure 1

EAST KENTUCKY NETWORK
101 TECHNOLOGY TRAIL
LIBERTY, KY 41642
PHONE: (606) 874-7550
FAX: (606) 874-7551
EMAIL: INFO@EKN.COM
WEBSITE: WWW.EKN.COM

EAST KENTUCKY
NETWORK



VIA: U.S. CERTIFIED MAIL

(CASE NO. 2007-00486)

PUBLIC NOTICE

December 3, 2007

Danny Ray & Kathy Fannin
51 Wells Hill Lane
West Liberty, KY 41472

RE: Public Notice-Public Service Commission of Kentucky (Case No. 2007-00486)

East Kentucky Network, LLC d/b/a Appalachian Wireless has applied to the Public Service Commission of Kentucky for a Certificate of Public Convenience and Necessity to construct and operate a new facility to provide cellular telecommunications service. The proposed tower will be a 300 foot self-supporting tower with attached antennas extending upwards, and an equipment shelter located on a ridge near Wrigley approximately one mile north of the community of Redwine (38° 01' 53.9" N 83° 13' 34.4 W). A map showing the location of the proposed new facility is enclosed. This notice is being sent to you because you may own property or reside within a 500' radius of the proposed tower.

The Commission invites your comments regarding the proposed construction. You also have the right to **intervene** in this matter. The Commission must receive your initial communication within 20 days of the **date** of this letter as shown above.

Your comments and request for intervention should be addressed to: Executive Director's Office, Public Service Commission of Kentucky, P.O. Box 615, Frankfort, KY 40602. Please refer to Case No. 2007-00486 in your correspondence.

Sincerely,

Janice Robinson
Technical Site Coordinator
Enclosure 1

EAST KENTUCKY NETWORK
101 TECHNOLOGY TRAIL
IVEL, KY 41642
PHONE: (606) 874-7550
FAX: (606) 874-7551
E-MAIL: INFO@EKN.COM
WWW.EKN.COM

EAST KENTUCKY
NETWORK



VIA: U.S. CERTIFIED MAIL

(CASE NO. 2007-00486)

PUBLIC NOTICE

December 3, 2007

Elton & Brenda Oneal
11808 HWY 7
West Liberty, KY 41472

RE: Public Notice-Public Service Commission of Kentucky (Case No. 2007-00486)

East Kentucky Network, LLC d/b/a Appalachian Wireless has applied to the Public Service Commission of Kentucky for a Certificate of Public Convenience and Necessity to construct and operate a new facility to provide cellular telecommunications service. The proposed tower will be a 300 foot self-supporting tower with attached antennas extending upwards, and an equipment shelter located on a ridge near Wrigley approximately one mile north of the community of Redwine (38° 01' 53.9" N 83° 13' 34.4 W). A map showing the location of the proposed new facility is enclosed. This notice is being sent to you because you may own property or reside within a 500' radius of the proposed tower.

The Commission invites your comments regarding the proposed construction. You also have the right to intervene in this matter. The Commission must receive your initial communication within 20 days of the date of this letter as shown above.

Your comments and request for intervention should be addressed to: Executive Director's Office, Public Service Commission of Kentucky, P.O. Box 615, Frankfort, KY 40602. Please refer to Case No. 2007-00486 in your correspondence.

Sincerely,

Janice Robinson
Technical Site Coordinator
Enclosure 1

EAST KENTUCKY NETWORK
101 TECHNOLOGY TRAIL
IVEL, KY 41642
PHONE: (606) 874-7550
FAX: (606) 874-7551
EMAIL: INFO@EKN.COM
WWW: WWW.EKN.COM



VIA: U.S. CERTIFIED MAIL

(CASE NO. 2007-00486)

PUBLIC NOTICE

December 3, 2007

Gary Bishop
11808 HWY 7
West Liberty, KY 41472

RE: Public Notice-Public Service Commission of Kentucky (Case No. 2007-00486)

East Kentucky Network, LLC d/b/a Appalachian Wireless has applied to the Public Service Commission of Kentucky for a Certificate of Public Convenience and Necessity to construct and operate a new facility to provide cellular telecommunications service. The proposed tower will be a 300 foot self-supporting tower with attached antennas extending upwards, and an equipment shelter located on a ridge near Wrigley approximately one mile north of the community of Redwine (38° 01' 53.9" N 83° 13' 34.4 W). A map showing the location of the proposed new facility is enclosed. This notice is being sent to you because you may own property or reside within a 500' radius of the proposed tower.

The Commission invites your comments regarding the proposed construction. You also have the right to intervene in this matter. The Commission must receive your initial communication within 20 days of the date of this letter as shown above.

Your comments and request for intervention should be addressed to: Executive Director's Office, Public Service Commission of Kentucky, P.O. Box 615, Frankfort, KY 40602. Please refer to Case No. 2007-00486 in your correspondence.

Sincerely,

A handwritten signature in cursive script that reads "Janice Robinson".

Janice Robinson
Technical Site Coordinator
Enclosure 1

EAST KENTUCKY NETWORK
101 TECHNOLOGY TRAIL
GLENVILLE, KY 41642
PHONE: (606) 874-7550
FAX: (606) 874-7551
EMAIL: INFO@EKN.COM
WEBSITE: WWW.EKN.COM



VIA: U.S. CERTIFIED MAIL

(CASE NO. 2007-00486)

PUBLIC NOTICE

December 3, 2007

Mike Ross, Inc. & ETAL
C/O Trio Petroleum Corp.
P.O. Box 880
Glenville, WV 26351

RE: Public Notice-Public Service Commission of Kentucky (Case No. 2007-00486)

East Kentucky Network, LLC d/b/a Appalachian Wireless has applied to the Public Service Commission of Kentucky for a Certificate of Public Convenience and Necessity to construct and operate a new facility to provide cellular telecommunications service. The proposed tower will be a 300 foot self-supporting tower with attached antennas extending upwards, and an equipment shelter located on a ridge near Wrigley approximately one mile north of the community of Redwine (38° 01' 53.9" N 83° 13' 34.4 W). A map showing the location of the proposed new facility is enclosed. This notice is being sent to you because you may own property or reside within a 500' radius of the proposed tower.

The Commission invites your comments regarding the proposed construction. You also have the right to intervene in this matter. The Commission must receive your initial communication within 20 days of the date of this letter as shown above.

Your comments and request for intervention should be addressed to: **Executive Director's Office**, Public Service Commission of Kentucky, P.O. Box 615, Frankfort, KY 40602. Please refer to Case No. 2007-00486 in your correspondence.

Sincerely,

A handwritten signature in cursive script that reads "Janice Robinson".

Janice Robinson
Technical Site Coordinator
Enclosure 1

EAST KENTUCKY NETWORK
101 TECHNOLOGY TRAIL
PIKEVILLE, KY 41502
PHONE: (606) 874-7550
FAX: (606) 874-7551
E-MAIL: INFO@EKN.COM
WWW: WWW.EKN.COM



VIA: U.S. CERTIFIED MAIL

(CASE NO. 2007-00486)

PUBLIC NOTICE

December 3, 2007

Maurice Newsome
Box 2195
Pikeville, KY 41501

RE: Public Notice-Public Service Commission of Kentucky (Case No. 2007-00486)

East Kentucky Network, LLC d/b/a Appalachian Wireless has applied to the Public Service Commission of Kentucky for a Certificate of Public Convenience and Necessity to construct and operate a new facility to provide cellular telecommunications service. The proposed tower will be a 300 foot self-supporting tower with attached antennas extending upwards, and an equipment shelter located on a ridge near Wrigley approximately one mile north of the community of Redwine (38° 01' 53.9" N 83° 13' 34.4 W). A map showing the location of the proposed new facility is enclosed. This notice is being sent to you because you may own property or reside within a 500' radius of the proposed tower.

The Commission invites your comments regarding the proposed construction. You also have the right to intervene in this matter. The Commission must receive your initial communication within 20 days of the date of this letter as shown above.

Your comments and request for intervention should be addressed to: Executive Director's Office, Public Service Commission of Kentucky, P.O. Box 615, Frankfort, KY 40602. Please refer to Case No. 2007-00486 in your correspondence.

Sincerely,

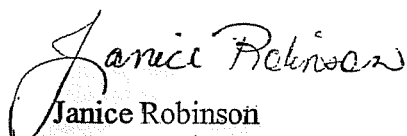
Janice Robinson
Technical Site Coordinator
Enclosure 1

EAST KENTUCKY NETWORK
101 TECHNOLOGY TRAIL
IVEL, KY 41642
PHONE: (606) 874-7550
FAX: (606) 874-7551
INFO@EKN.COM
WWW.EKN.COM

EAST KENTUCKY
NETWORK



VIA: U.S. CERTIFIED MAIL

(CASE NO. 2007-00486)

PUBLIC NOTICE

December 3, 2007

Emory Cecil Smith
12154 HWY 7
West Liberty, KY 41472

RE: Public Notice-Public Service Commission of Kentucky (Case No. 2007-00486)

East Kentucky Network, LLC d/b/a Appalachian Wireless has applied to the Public Service Commission of Kentucky for a Certificate of Public Convenience and Necessity to construct and operate a new facility to provide cellular telecommunications service. The proposed tower will be a 300 foot self-supporting tower with attached antennas extending upwards, and an equipment shelter located on a ridge near Wrigley approximately one mile north of the community of Redwine (38° 01' 53.9" N 83° 13' 34.4 W). A map showing the location of the proposed new facility is enclosed. This notice is being sent to you because you may own property or reside within a 500' radius of the proposed tower.

The Commission invites your comments regarding the proposed construction. You also have the **right to intervene in this matter**. The Commission must receive your initial communication within 20 days of the date of this letter as shown above.

Your comments and request for intervention should be addressed to: **Executive Director's Office**, Public Service Commission of Kentucky, P.O. Box 615, Frankfort, KY 40602. Please refer to Case No. 2007-00486 in your correspondence.

Sincerely,

Janice Robinson
Technical Site Coordinator
Enclosure 1

Location Map

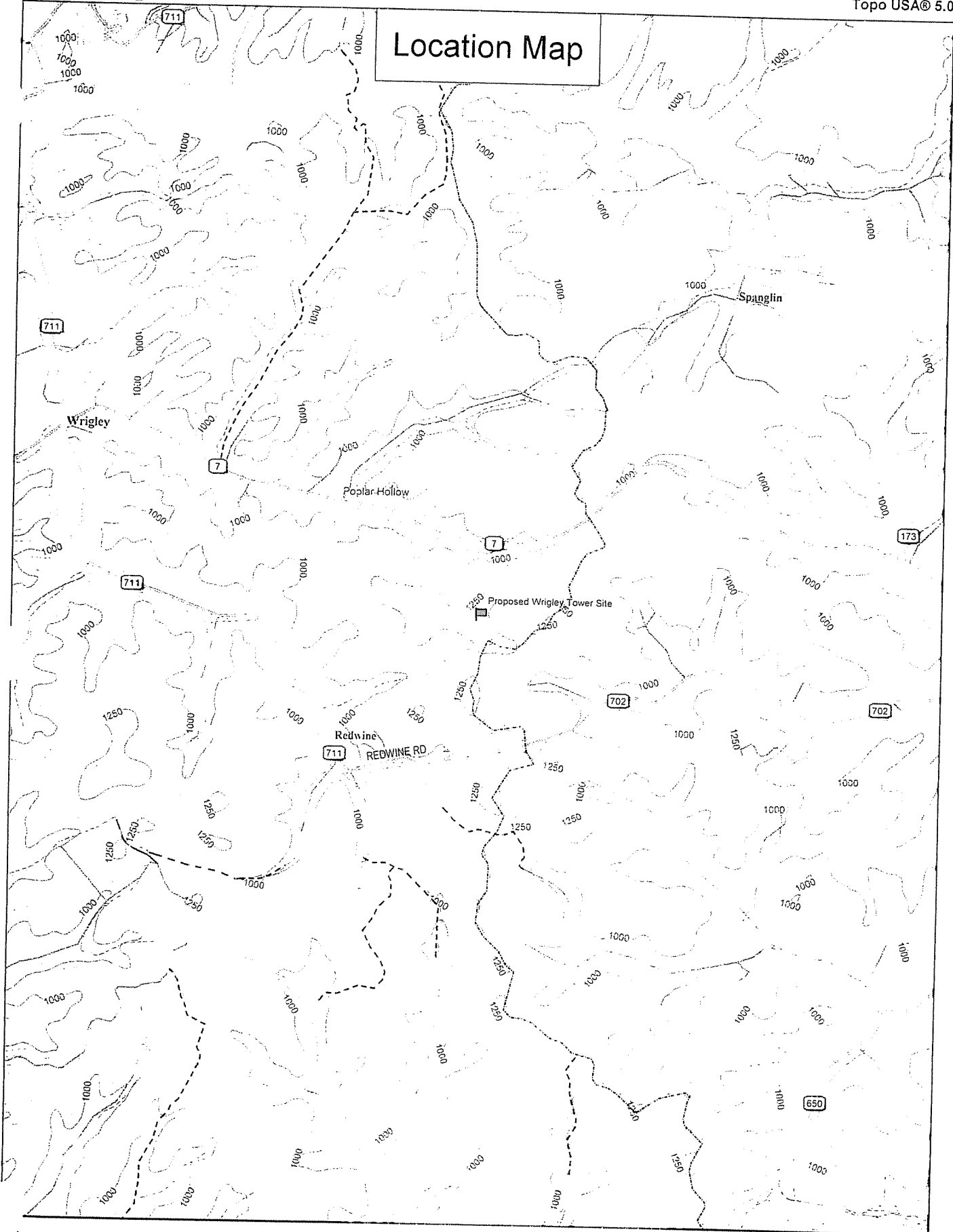

Data use subject to license
© 2004 DeLorme, Topo USA® 5.0
www.delorme.com

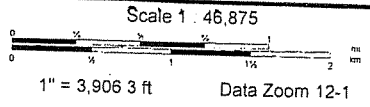
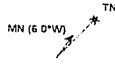

WENDELL R. HOLMES, P.G.

120 Church Street
Whitesburg, KY 41858
(606) 633-1511

August 3, 2007

Wrigley Tower Site

Purpose:

A site assessment was conducted for Appalachian Wireless on a tract of land located in Morgan County near Wrigley, Kentucky. The site of the proposed tower is now forestland. The purpose of this investigation was to determine the depth to bedrock and of what type of rock the bedrock consists.

Site Investigation:

The trenching method was used to determine the type of bedrock material at the proposed tower site. A Caterpillar 320 excavator was used to expose the bedrock material. It is approximately 2.75 feet to the sandstone bedrock. (See attached page for descriptions of materials encountered.)

The terrain in Morgan County is slightly to moderately steep. The tower site is located on a ridge between Road Fork and North Fork, both are tributaries of the Licking River, approximately one mile north of the community of Redwine. The sandstone formation below the tower site is approximately 10.00 feet thick based on the information obtained from the site investigation and geological maps of the area.

Conclusions:

The proposed tower site is located on a ridge in the area. The sandstone bedrock on the proposed tower site is part of the Breathitt Formation, and is middle to lower Pennsylvanian in age. Tests were not conducted to determine the load-bearing strength of the bedrock. However, it is apparent that the tower will be constructed on the sandstone bedrock formation.

The field work for this site was performed by Wendell R. Holmes, using generally accepted methods in the practice of geological science.

Wendell R. Holmes

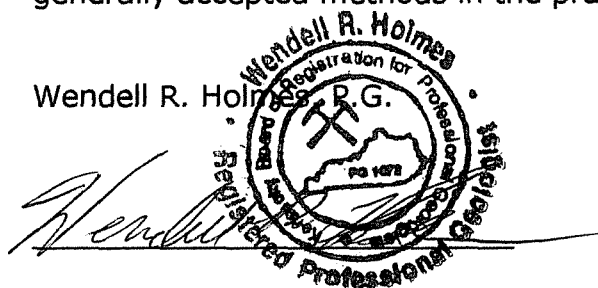

WENDELL R. HOLMES, P.G.

**120 Church Street
Apartment 3
Whitesburg, Ky. 41858**

Geologist Log

Location: Wrigley Tower Site

Unit Thickness	Total depth	Strata	Description
2.00'	2.00'	Soil	yellow and brown, with shale and plant fragments
0.25'	2.25'	Coal	black and weathered
0.50'	2.75'	Fireclay	gray and weathered
10.00'	12.75'	Sandstone	gray, brown with some shale streaks



Kentucky Transportation Cabinet, Kentucky Airport Zoning Commission, 200 Mero Street, Frankfort, KY 40622

Kentucky Aeronautical Study Number

APPLICATION FOR PERMIT TO CONSTRUCT OR ALTER A STRUCTURE

INSTRUCTIONS INCLUDED

1 APPLICANT -- Name, Address, Telephone, Fax, etc
 East Kentucky Network, LLC
 c/o Lukas, Nace, Gutierrez & Sachs, Chtd
 1650 Tysons Blvd, Suite 1500
 McLean, VA 22102
 T: 703-584-8667 F: 703-584-8692

2 Representative of Applicant -- Name, Address, Telephone, Fax
 Ali Kuzehkanani
 Lukas, Nace, Gutierrez & Sachs, Chtd
 1650 Tysons Blvd, Suite 1500
 McLean, VA 22102
 T: 703-584-8667 F: 703-584-8692

3. Application for: New Construction Alteration Existing
 4 Duration: Permanent Temporary (Months _____ Days _____)
 5 Work Schedule: Start 12/1/2007 End 12/15/2007
 6 Type: Antenna Tower Crane Building Power Line
 Landfill Water Tank Other _____
 Marking/Painting and/or Lighting Preferred:
 Red Lights and Paint Dual - Red & Medium Intensity White
 White - Medium Intensity Dual - Red & High Intensity White
 White - High Intensity Other _____
 8. FAA Aeronautical Study Number _____

9 Latitude: 38 ° 01 ' 53 " 9 "
 10 Longitude: 83 ° 13 ' 34 " 4 "
 11 Datum: NAD83 NAD27 Other _____
 12. Nearest Kentucky City: Wrigley County Morgan
 13 Nearest Kentucky public use or Military airport:
West Liberty
 14 Distance from #13 to Structure: 8.7 mi
 15 Direction from #13 to Structure: North
 16 Site Elevation (AMSL): 1,340.00 Feet
 17 Total Structure Height (AGL): 315.00 Feet
 18 Overall Height (#16 + #17) (AMSL): 1,655.00 Feet
 19 Previous FAA and/or Kentucky Aeronautical Study Number(s):

 20 Description of Location: (Attach USGS 7 5 minute Quadrangle Map or an Airport layout Drawing with the precise site marked and any certified survey)
 Site is located approx 2.6 mi (4.2 km) ENE of Wrigley (Morgan), KY

21 Description of Proposal:
 The structure will include a 300' tower with top-mounted cellular antennas (overall height of 315' AGL) The ERP will be 500 watts

22 Has a "NOTICE OF CONSTRUCTION OR ALTERATION" (FAA Form 7460-1) been filed with the Federal Aviation Administration?
 No Yes, When November 16, 2007

CERTIFICATION: I hereby certify that all the above statements made by me are true, complete and correct to the best of my knowledge and belief.
 All Kuzehkanani/Dir of Engineering Ali Kuzehkanani 11/16/2007
 Printed Name and Title Signature Date

PENALTIES: Persons failing to comply with Kentucky Revised Statutes (KRS 183.861 through 183.990) and Kentucky Administrative Regulations (602 KAR 050:Series) are liable for fines and/or imprisonment as set forth in KRS 183.990(3) Non-compliance with Federal Aviation Administration Regulations may result in further penalties

Commission Action: Chairman, KAZC Administrator, KAZC
 Approved _____
 Disapproved _____ Date _____

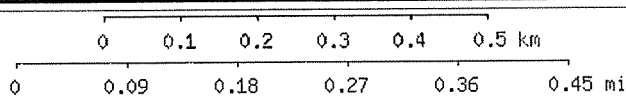

38° 01' 54"N, 83° 13' 34"W (NAD83/WGS84)
USGS Sandy Hook (KY) Quadrangle
Projection is UTM Zone 17 NAD83 Datum



M=-5.977
G=-1.372

LEG DIA.	Ø4.25"	Ø4.25"	Ø4"	Ø4"	Ø3.75"	Ø3.7"	Ø3.5"	Ø3.25"	Ø3"	Ø3"	Ø2.75"	Ø2.5"	Ø2.25"				
DIAGONALS	L3.5" x .25"		L3" x .1875"		L2.5" x .1875"		L2" x .1875"		A								
GIRTS	N/A																
BRACE BOLTS	Ø.875"		Ø.75"		Ø.625"		Ø.5"						Ø.75"				
FLANGE BOLTS	Ø1.25"		Ø1"														
# OF BAYS	3 BAY : X-BRACED			4 BAY : X-BRACED													

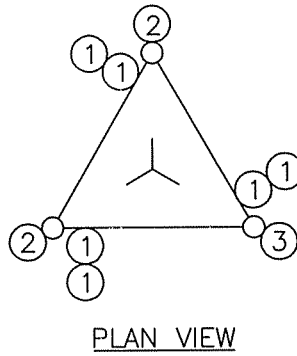
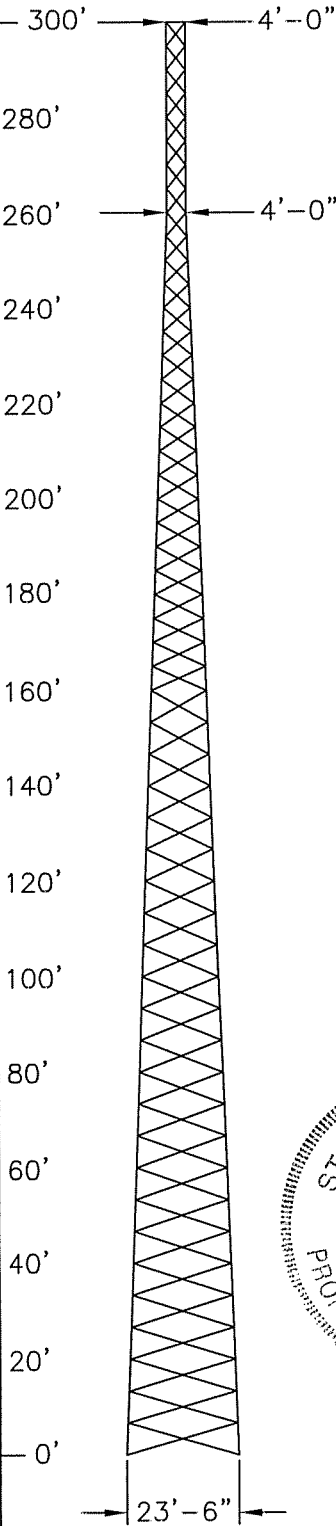

PLAN VIEW REF:
 1) (6) 1.625" LINES
 2) (1) 1.625" LINE
 3) STEP BOLTS

SYMBOL LIST:	
A	= L1.75" x .1875"
BASE REACTIONS:	
TOTAL SHEAR	= 39 KIPS
AXIAL LOAD	= 71 KIPS
UPLIFT / LEG	= 294 KIPS
COMP. / LEG	= 342 KIPS
O.T. MOMENT	= 6466 FT-K

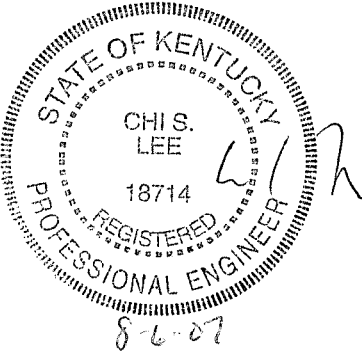

DESIGN NOTES:
 1) ALL LEGS ARE SOLID ROUND ASTM A-572 GRADE : Fy ≥ 50 KSI.
 2) ALL BRACE MATERIAL IS ASTM A-36 : Fy ≥ 36 KSI.
 3) ALL BRACE AND FLANGE BOLTS ARE A325-X
 4) (8) Ø1.5" x 6'-0" LONG (A-36) ANCHOR BOLTS PER LEG.
 5) THIS TOWER IS DESIGNED FOR A 70 M.P.H. BASIC WIND SPEED IN ACCORDANCE WITH THE TIA/EIA-222-F STANDARD INCLUDING A 1/2" OF RADIAL ICE (WITH REDUCTION).

ELEV.	ANTENNAS	FEEDLINES
300'	(12) 4' x 1' CELLULAR PANEL	(12) 1.625"
290'	(12) 4' x 1' CELLULAR PANEL	(12) 1.625"
280'	(12) 4' x 1' CELLULAR PANEL	(12) 1.625"
270'	(2) 8' HP DISH	(2) 1.625"
---SEE PLAN VIEW FOR FEEDLINE DISTRIBUTION		
---STEP BOLTS UTILIZED FOR CLIMBING WITH SAFETY CLIMB DEVICE		



P.O. BOX 25
 HENDERSON, KY 42419
 PHONE: (270) 830-8512
 FAX: (270) 830-8475

SCALE: N.T.S.	PROPRIETARY STATEMENT: THIS DRAWING IS THE PROPERTY OF ALLSTATE TOWER CO. IT IS NOT TO BE REPRODUCED OR COPIED IN ANYWAY WITHOUT PRIOR WRITTEN CONSENT OF ALLSTATE TOWER CO.
TOLERANCE BANDS ALL DIMENSIONS ARE ±1/16" ALL ANGULAR DIM ARE ±1/2° UNLESS OTHERWISE NOTED	CUSTOMER: APPALACHIAN WIRELESS
APPROX. WEIGHT 50.94 KIPS	DESCRIPTION: 300' SELF SUPPORT TOWER
	LOCATION: MORGAN COUNTY, KY.
	SITE: WRIGLEY
	PROPOSAL #: AB1492 - S.S.T. PROPOSAL
	DRAWN BY: J.B.
	DATE: 08/04/2007
	REV: REV. NO.
	REV. DATE: REV. DATE
	JOB NO. AF40797
	SHEET A



P.O. BOX 25
 HENDERSON, KY 42419
 PHONE: (270) 830-8512
 FAX: (270) 830-8475

SCALE: N.T.S.		PROPRIETARY STATEMENT: THIS DRAWING IS THE PROPERTY OF ALLSTATE TOWER CO. IT IS NOT TO BE REPRODUCED OR COPIED IN ANYWAY WITHOUT PRIOR WRITTEN CONSENT OF ALLSTATE TOWER CO.	
TOLERANCE BANDS ALL DIMENSIONS ARE ±1/16" ALL ANGULAR DIM ARE ±1/2° UNLESS OTHERWISE NOTED		CUSTOMER: APPALACHIAN WIRELESS	DRAWN BY: J.B.
APPROX. WEIGHT N/A		DESCRIPTION: PAD/PIER FOUNDATION DESIGN	DATE: 08/04/2007
PROPOSAL # AB1492 - SELF SUPPORT TOWER		LOCATION: MORGAN COUNTY, KY.	REV. DATE: REV. DATE
		SITE: WRIGLEY	REV. NO.
			REV. DATE
			JOB NO.
			REVISIONS
			AF40797
			B

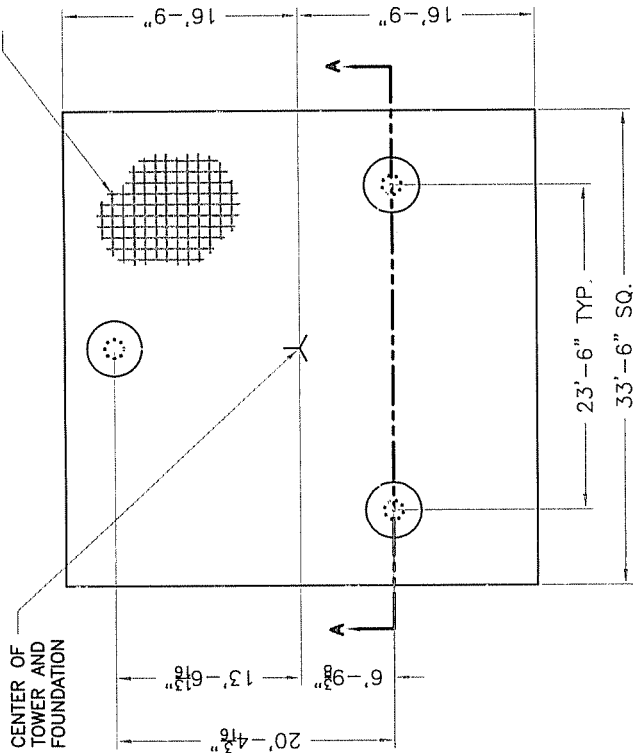

PLAN VIEW

TOTAL VOLUME OF CONCRETE = 87 YD³

FOUNDATION INSTALLATION/DESIGN NOTES:

- THIS FOUNDATION IS DESIGNED TO MEET ALL STANDARDS SET FORTH BY ACI 318: AMERICAN CONCRETE INSTITUTE, BUILDING CODE REQUIREMENTS FOR STRUCTURAL CONCRETE, ANSI/TIA/EIA 222-F: STRUCTURAL STANDARDS FOR STEEL ANTENNA TOWERS AND ANTENNA SUPPORTING STRUCTURES. THIS FOUNDATION IS DESIGNED UTILIZING THE GEOTECHNICAL REPORT PERFORMED BY WENDELL R. HOLMES, P.G.; DATED 8-03-07; THE FOUNDATION CONTRACTOR SHALL INSTALL THE FOUNDATIONS IN ACCORDANCE WITH THE RECOMMENDATIONS OF THE GEOTECHNICAL REPORT.
- ALL WORK PERFORMED FROM THESE DRAWINGS SHOULD BE BY QUALIFIED CONTRACTORS EXPERIENCED IN TOWER FOUNDATION CONSTRUCTION.
- ALL FOOTING EXCAVATIONS SHALL BE MANUALLY CLEANED PRIOR TO PLACING CONCRETE. COMPACT THE EXPOSED SOIL SURFACE AND ANY GRANULAR FILL UNDER THE FOUNDATION TO 95% OF THE MODIFIED PROCTOR DENSITY.
- ALL CONCRETE SHALL HAVE A MINIMUM COMPRESSIVE STRENGTH OF 3000 PSI AFTER 28 DAYS. COPIES OF THE CONCRETE CYLINDER TEST REPORTS SHALL BE SENT TO THE RESIDENT ENGINEER / INSPECTOR.
- MINIMUM CONCRETE COVER FOR REINFORCING BARS SHALL BE 3". FIELD BENDING OR WELDING OF REINFORCEMENT BARS IS NOT PERMITTED.
- PROVIDE CHAMFERS AT ALL EXPOSED CORNERS OF CONCRETE.
- BACKFILL NEAR AND AROUND THE FOUNDATIONS SHALL BE A WELL GRADED FILL MATERIAL PLACED IN 8" THICK LAYERS THAT HAS BEEN COMPACTED TO 95% OF THE MODIFIED PROCTOR DENSITY PER ASTM D1557.
- SOME DETAIL HAS BEEN PURPOSELY OMITTED TO CLARIFY ILLUSTRATION.

REINFORCEMENT BAR MAT

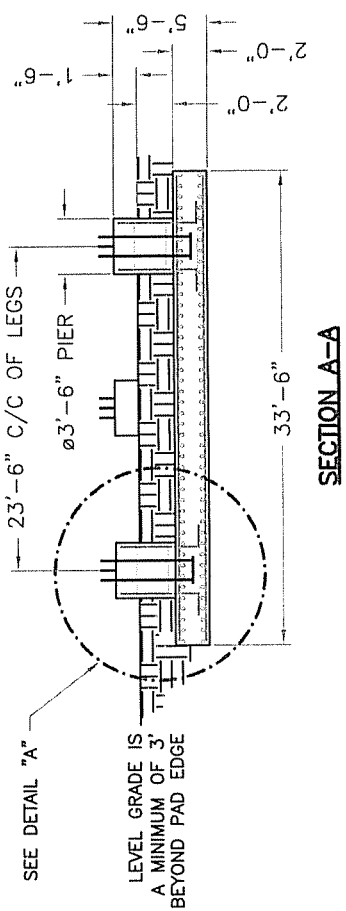

SECTION A-A

(8) ϕ 1-1/2" X 6'-0" OVERALL LENGTH ANCHOR BOLTS W/ 3/4" THK BEARING PLATE AT THE BOTTOM OF THE ANCHOR BOLT CLUSTER (5' MIN. ANCHOR BOLT EMBEDMENT).

USE EPOXY BONDING AGENT WHEN POURED SEPERATELY

(10) #9 VERTICAL BARS W/ #4 TIES AT 12" ON CENTER

(37) #9 HORIZONTAL BARS X 33'-0" LONG EQUALLY SPACED EACH WAY AT TOP AND BOTTOM OF MAT. (TOTAL = 148)

DETAIL "A"

REINFORCEMENT BAR SPlicing:

- ALL LAP SPICES SHALL CONFORM TO ACI 318 REQUIREMENTS. REFER TO CHART BELOW WHEN REINFORCEMENT BAR SPlicing IS NECESSARY.

REINFORCING BAR SIZE	LAP SPlice LENGTH
3	15"
4	17"
5	21"
6	26"
7	30"
8	36"
9	46"
10	58"
11	71"

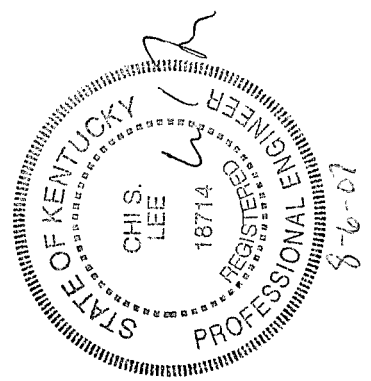

LUKAS, NACE, GUTIERREZ & SACHS

CHARTERED

1650 TYSONS BOULEVARD, SUITE 1500
MCLEAN, VIRGINIA 22102
703 584 8678 • 703 584 8696 FAX

WWW.FCCLAW.COM

RUSSELL D. LUKAS
DAVID L. NACE
THOMAS GUTIERREZ*
ELIZABETH R. SACHS*
GEORGE L. LYON, JR.
PAMELA L. GIST
DAVID A. LAFURIA
TODD SLAMOWITZ*
B. LYNN F. RATNAVALE*
STEVEN M. CHERNOFF*
KATHERINE PATSAS*

CONSULTING ENGINEERS
ALI KUZEHKANANI
LEILA REZANAVAZ
—
OF COUNSEL
LEONARD S. KOLSKY*
JOHN CIMKO*
J. K. HASE III*
JOHN J. MCAVOY*
HON. GERALD S. MCGOWAN*
TAMARA DAVIS-BROWN*

*NOT ADMITTED IN VA

Writers Direct Dial
(703) 584-8667
akuzehkanani@fcclaw.com

November 16, 2007

Via U.S. Mail

EXPRESS PROCESSING CENTER
Federal Aviation Administration
Southwest Regional Office
Air Traffic Airspace Branch, ASW-520
2601 Meacham Blvd.
Fort Worth, TX 76137-4298

Dear FAA Evaluator:

Enclosed is an FAA Form 7460-1 (Notice of Proposed Construction or Alteration) for a new 315' communications tower structure (300' tower plus 15' antenna/lightning rod) near Wrigley (Morgan), Kentucky. The site ("Wrigley") is approximately 2.6 mi (4.2 kilometers) ENE of Wrigley.

The proponent, East Kentucky Network, LLC, is the licensee for Cellular Block B service in Kentucky 9 - Elliot Rural Service Area (KY9B RSA), Market No. 451B. Transmit technology to be employed at this station is CDMA in the Cellular Band B frequency band (880 - 890 MHz and 891 - 894 MHz); the maximum ERP is 500 Watts.

The transmitting systems at this site will be installed and maintained such that transmitter spurious radiation in the frequency range of 118 MHz to 137 MHz is attenuated at least 71 dB below the unmodulated carrier level.

Should you have any questions or require additional information, please do not hesitate to call the undersigned at the above identified telephone number.

Sincerely,

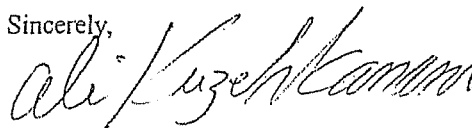

Ali Kuzehkanani
Director of Engineering

Enclosure

cc: East Kentucky Network, LLC
Attention: Paul DeLong and Gerald Robinett

**EAST KENTUCKY NETWORK, LLC
DBA APPALACHIAN WIRELESS**

FINANCIAL REPORT

December 31, 2006

CONTENTS

	Page
INDEPENDENT AUDITOR'S REPORT ON THE FINANCIAL STATEMENTS	1
FINANCIAL STATEMENTS	
Balance sheets	2
Statements of income	3
Statements of members' equity	4
Statements of cash flows	5-6
Notes to financial statements	7-13
INDEPENDENT AUDITOR'S REPORT ON THE SUPPLEMENTARY INFORMATION	14
SUPPLEMENTARY INFORMATION	
Statement of income detail	15 and 16

INDEPENDENT AUDITOR'S REPORT

To the Members
East Kentucky Network, LLC
dba Appalachian Wireless
Ivel, Kentucky 41642

We have audited the accompanying balance sheets of East Kentucky Network, LLC, dba Appalachian Wireless as of December 31, 2006 and 2005 and the related statements of income, members' equity and cash flows for the years then ended. These financial statements are the responsibility of the Company's management. Our responsibility is to express an opinion on these financial statements based on our audits.

We conducted our audits in accordance with auditing standards generally accepted in the United States of America. Those standards require that we plan and perform the audit to obtain reasonable assurance about whether the financial statements are free of material misstatement. An audit includes examining, on a test basis, evidence supporting the amounts and disclosures in the financial statements. An audit also includes assessing the accounting principles used and significant estimates made by management, as well as evaluating the overall financial statement presentation. We believe that our audits provide a reasonable basis for our opinion.

In our opinion, the financial statements referred to above present fairly, in all material respects, the financial position of East Kentucky Network, LLC, dba Appalachian Wireless as of December 31, 2006 and 2005 and the results of its operations and its cash flows for the years then ended in conformity with accounting principles generally accepted in the United States of America.

Jones, Nale & Mattingly P.C.

Louisville, Kentucky
March 15, 2007

**EAST KENTUCKY NETWORK, LLC
DBA APPALACHIAN WIRELESS**

**BALANCE SHEETS
December 31, 2006 and 2005**

ASSETS	<u>2006</u>	<u>2005</u>
CURRENT ASSETS		
Cash and cash equivalents	\$ 2,818,346	\$ 1,046,669
Short-term investments	46,271	43,803
Accounts receivable, less allowance for doubtful accounts of \$567,790 in 2006 and \$375,856 in 2005	2,802,673	1,560,267
Accounts receivable, members (Notes 5 and 6)	37,612	3,149
USF receivable (Note 7)	--	589,913
Inventory	1,584,039	1,056,766
Prepaid expenses	<u>173,657</u>	<u>143,547</u>
Total current assets	<u>\$ 7,462,598</u>	<u>\$ 4,444,114</u>
 PROPERTY, PLANT AND EQUIPMENT (Note 3)		
Plant in service:		
General support	\$ 18,914,927	\$ 10,633,736
MTSO equipment	13,354,875	11,934,434
Cell equipment	39,339,797	34,785,982
Paging equipment	3,321,068	3,320,416
Fiber ring	6,471,128	6,245,412
Unfinished plant	<u>657,524</u>	<u>3,992,696</u>
	\$ 82,059,319	\$ 70,912,676
Less accumulated depreciation	<u>33,358,066</u>	<u>27,810,940</u>
	<u>\$ 48,701,253</u>	<u>\$ 43,101,736</u>
 OTHER ASSETS		
Investment in affiliated company, RTFC (Note 3)	\$ 862,394	\$ 875,133
Intangible assets, net of accumulated amortization of \$2,646,913 in 2006 and \$2,179,654 in 2005 (Note 2)	4,497,032	4,623,855
Other	<u>27,550</u>	<u>28,669</u>
	<u>\$ 5,386,976</u>	<u>\$ 5,527,657</u>
	<u>\$ 61,550,827</u>	<u>\$ 53,073,507</u>

The Notes to Financial Statements are an integral part of these statements.

LIABILITIES AND MEMBERS' EQUITY	<u>2006</u>	<u>2005</u>
CURRENT LIABILITIES		
Current maturities of long-term debt (Note 3)	\$ 1,200,000	\$ 48,033
Accounts payable	1,166,909	851,643
Accounts payable, member (Notes 5 and 6)	2,899	2,936
Accrued expenses	2,113,530	1,457,463
Accrued state corporation taxes	232,157	85,989
Customer deposits	<u>317,603</u>	<u>291,380</u>
Total current liabilities	\$ 5,033,098	\$ 2,737,444
LONG-TERM DEBT, less current maturities (Note 3)	13,000,000	13,297,220
MEMBERS' EQUITY	43,517,729	37,038,843
	<u>\$ 61,550,827</u>	<u>\$ 53,073,507</u>

**EAST KENTUCKY NETWORK, LLC
DBA APPALACHIAN WIRELESS**

**STATEMENTS OF INCOME
Years Ended December 31, 2006 and 2005**

	2006	2005
REVENUE		
Retail	\$ 24,156,320	\$ 20,908,570
Roamer	6,964,309	6,868,904
Long distance	155,046	177,350
Paging	852,011	1,039,429
Equipment sales, cellular	2,922,817	2,152,962
Equipment sales, paging	27,894	57,632
Other	3,065,078	2,359,809
Total revenue	\$ 38,143,475	\$ 33,564,656
EXPENSES		
Cost of cellular service	\$ 7,888,446	\$ 7,924,553
Cost of paging service	411,177	510,665
Cost of equipment sales, cellular	6,813,457	4,912,998
Cost of equipment sales, paging	58,755	78,428
Customer service	1,330,573	1,208,726
Billing	1,097,834	1,200,135
Selling	2,703,570	2,131,009
Maintenance	1,267,034	1,042,844
Utilities	454,008	354,870
Bad debts	800,268	672,263
Recovery of bad debts	(90,925)	(120,673)
Cell site rental	158,500	135,012
Taxes	565,271	257,247
Advertising	1,574,298	1,139,697
General and administrative	2,238,348	2,249,226
Occupancy	334,981	359,928
Depreciation	5,541,628	4,635,200
Amortization	508,526	495,241
Total expenses	\$ 33,655,749	\$ 29,187,369
Income from operations	\$ 4,487,726	\$ 4,377,287
OTHER INCOME (EXPENSE)		
Interest income	\$ 49,052	\$ 23,915
Interest expense	(821,277)	(795,898)
Universal Service Fund income (Note 7)	3,716,602	589,913
Impairment of goodwill (Note 8)	-	(331,286)
	\$ 2,944,377	\$ (513,356)
Income before taxes	\$ 7,432,103	\$ 3,863,931
Kentucky corporation tax expense	399,157	170,197
Net income	\$ 7,032,946	\$ 3,693,734

The Notes to Financial Statements are an integral part of these statements.

**EAST KENTUCKY NETWORK, LLC
DBA APPALACHIAN WIRELESS**

**STATEMENTS OF MEMBERS' EQUITY
Years Ended December 31, 2006 and 2005**

	Cellular Services, Inc.	Gearhart Communi- cations Company, Inc.	Mountain Tele- communi- cations, Inc.	Thacker- Grigsby Telephone Co., Inc.	Peoples Rural Telephone Coop- erative Corp- oration, Inc.	Total
Balance, January 1, 2005	\$ 6,781,309	\$ 6,781,309	\$ 6,781,309	\$ 6,781,309	\$ 6,781,308	\$33,906,544
Net income	738,747	738,747	738,747	738,746	738,747	3,693,734
Capital distributions	<u>(112,287)</u>	<u>(112,287)</u>	<u>(112,287)</u>	<u>(112,287)</u>	<u>(112,287)</u>	<u>(561,435)</u>
Balance, December 31, 2005	\$ 7,407,769	\$ 7,407,769	\$ 7,407,769	\$ 7,407,768	\$ 7,407,768	\$37,038,843
Net income	1,406,589	1,406,589	1,406,589	1,406,590	1,406,589	7,032,946
Capital distributions	<u>(110,812)</u>	<u>(110,812)</u>	<u>(110,812)</u>	<u>(110,812)</u>	<u>(110,812)</u>	<u>(554,060)</u>
Balance, December 31, 2006	<u>\$ 8,703,546</u>	<u>\$ 8,703,546</u>	<u>\$ 8,703,546</u>	<u>\$ 8,703,546</u>	<u>\$ 8,703,545</u>	<u>\$43,517,729</u>

The Notes to Financial Statements are an integral part of these statements.

**EAST KENTUCKY NETWORK, LLC
DBA APPALACHIAN WIRELESS**

**STATEMENTS OF CASH FLOWS
Years Ended December 31, 2006 and 2005**

	2006	2005
CASH FLOWS FROM OPERATING ACTIVITIES		
Net income	\$ 7,032,946	\$ 3,693,734
Adjustments to reconcile net income to net cash provided by operating activities:		
Depreciation	5,541,628	4,635,200
Amortization	508,526	495,241
Impairment of goodwill	--	331,286
Changes in assets and liabilities, net of the effects of investing and financing activities:		
(Increase) in accounts receivable	(1,242,406)	(78,367)
Decrease in accounts receivable, members	(34,463)	51,248
(Increase) decrease in USF receivable	589,913	(589,913)
(Increase) in inventory	(527,273)	(230,130)
(Increase) decrease in prepaid expenses	(30,110)	5,012
(Increase) decrease in other assets	13,858	(646)
Increase (decrease) in accounts payable	315,266	(291,123)
Increase (decrease) in accounts payable, member	(37)	2,332
Increase in accrued expenses	656,067	339,038
Increase in accrued state corporation taxes	146,168	85,989
Increase in customer deposits	26,223	139,030
Net cash provided by operating activities	\$ 12,996,306	\$ 8,587,931
CASH FLOWS FROM INVESTING ACTIVITIES		
Purchase of property, plant and equipment	\$ (11,182,411)	\$ (11,469,668)
Purchase of intangible assets	(340,437)	(299,159)
Proceeds from sale of short-term investments	(2,468)	56,197
Net cash (used in) investing activities	\$ (11,525,316)	\$ (11,712,630)
CASH FLOWS FROM FINANCING ACTIVITIES		
Capital distributions	\$ (554,060)	\$ (561,435)
Proceeds from long-term borrowings	14,200,000	3,450,000
Payments on long-term borrowings	(13,345,253)	(832,731)
Net cash provided by financing activities	\$ 300,687	\$ 2,055,834
Net increase (decrease) in cash and cash equivalents	\$ 1,771,677	\$ (1,068,865)
Cash and cash equivalents:		
Beginning	1,046,669	2,115,534
Ending	\$ 2,818,346	\$ 1,046,669

The Notes to Financial Statements are an integral part of these statements.

**EAST KENTUCKY NETWORK, LLC
DBA APPALACHIAN WIRELESS**

**STATEMENTS OF CASH FLOWS (Continued)
Years Ended December 31, 2006 and 2005**

	<u>2006</u>	<u>2005</u>
SUPPLEMENTAL DISCLOSURE OF CASH FLOW INFORMATION		
Cash payments for interest	<u>\$ 866,941</u>	<u>\$ 788,610</u>
Cash payments for state corporation taxes	<u>\$ 167,000</u>	<u>\$ 84,207</u>
SUPPLEMENTAL SCHEDULE OF NONCASH INVESTING AND FINANCING ACTIVITIES		
Settlement of note payable from impairment of goodwill	<u>\$ --</u>	<u>\$ 400,000</u>
Settlement of accrued interest from impairment of goodwill	<u>\$ --</u>	<u>\$ 56,000</u>

The Notes to Financial Statements are an integral part of these statements.

**EAST KENTUCKY NETWORK, LLC
DBA APPALACHIAN WIRELESS**

NOTES TO FINANCIAL STATEMENTS

Note 1. Summary of Significant Accounting Policies

Nature of operations

East Kentucky Network, LLC, dba Appalachian Wireless, is a Kentucky limited liability company formed by the merger of Appalachian Cellular, LLC, Mountaineer Cellular, LLC and East Kentucky Network, LLC on January 1, 2000. The Company is engaged in cellular telephone communications and paging services to residential and commercial customers located in eastern Kentucky. The Company's five members consist of Cellular Services, Inc.; Gearheart Communications Company, Inc.; Mountain Telecommunications, Inc.; Peoples Rural Telephone Cooperative Corporation, Inc.; and Thacker-Grigsby Telephone Co., Inc.

Cash

The Company maintains its cash balances, which exceed the \$100,000 federally insured limit, with several financial institutions. These financial institutions have strong credit ratings and management believes that credit risk related to the accounts is minimal.

Cash equivalents

For purposes of the statement of cash flows, the Company considers temporary investments having a maturity of three months or less to be cash equivalents.

Short-term investments

Certificates of deposit having original maturities between three and nine months are classified as short-term investments, are carried at cost, which approximates fair value, and are held to maturity.

Inventory

Inventory is composed of cellular telephone equipment, paging equipment, and accessories purchased for resale during the ordinary course of business. The inventory is valued at the lower of cost or market, cost being determined by the first-in, first-out (FIFO) method.

Property, plant and equipment

Property, plant and equipment are recorded at cost. Depreciation is provided using the straight-line method over the estimated useful lives of the assets.

Investment

The investment in affiliated company is composed of equity certificates in Rural Telephone Finance Cooperative and is reported at cost, which approximates fair value.

NOTES TO FINANCIAL STATEMENTS

Note 1. Summary of Significant Accounting Policies (Continued)

Intangible assets

The customer lists, non-compete agreements, FCC licenses, and use of name are recorded at cost and are being amortized over 15 years by the straight-line method. The excess cost over the fair value of the net assets acquired (goodwill) related to paging acquisitions is measured for impairment on an annual basis, and written down, if necessary, to its estimated value at that time. During the prior year, the Company expensed the remaining balance of goodwill as an impairment (see Note 8).

Recognition of revenue

Cellular service and paging revenues are recognized when earned. Monthly access and feature charges are billed one month in advance and recognized as revenue the following month. Revenue from telephone and accessories sold are recognized as revenue upon delivery to the customer.

Advertising

Advertising costs are expensed as incurred. At December 31, 2006 and 2005, these costs were \$1,574,298 and \$1,139,697, respectively.

Income taxes

Under existing provisions of the Internal Revenue Code, the income or loss of a limited liability company is recognized by the members for income tax purposes. Accordingly, no provision for federal income taxes has been provided for in the accompanying financial statements. Effective for years beginning on or after January 1, 2005, the State of Kentucky enacted legislation which now provides for the taxation of limited liability companies' at the entity level. The accompanying financial statements include the related state tax liability under the new regulations.

Use of estimates

Management uses estimates and assumptions in preparing financial statements. Those estimates and assumptions affect the reported amounts of assets and liabilities, the disclosure of contingent assets and liabilities, and the reported revenues and expenses.

NOTES TO FINANCIAL STATEMENTS

Note 2. Intangible Assets

Intangible assets consist of the following at December 31, 2006:

	Gross Amount	Accumulated Amortization
Customer lists	\$ 5,363,530	\$ (2,152,951)
Non-compete agreements	220,348	(121,577)
FCC licenses	1,141,593	(330,542)
Use of name	10,000	(4,334)
Other	408,474	(37,509)
	\$ 7,143,945	\$ (2,646,913)

Intangible assets consist of the following at December 31, 2005:

	Gross Amount	Accumulated Amortization
Customer lists	\$ 5,363,530	\$ (1,795,634)
Non-compete agreements	220,348	(106,898)
FCC licenses	1,141,593	(264,446)
Use of name	10,000	(3,668)
Other	68,038	(9,008)
	\$ 6,803,509	\$ (2,179,654)

Aggregate amortization expense related to these intangible assets for the years ended December 31, 2006 and 2005 totaled \$467,259 and \$437,982, respectively. The following represents the total estimated amortization of intangible assets for each of the succeeding five years:

Year ending December 31:

2006	\$ 450,000
2007	450,000
2008	450,000
2009	450,000
2010	450,000

NOTES TO FINANCIAL STATEMENTS

Note 3. Long-Term Debt

Long-term debt consists of the following at December 31:

	2006	2005
Note payable, Fifth Third Bank (a) Dated 02/28/06, variable rate (5.41% at 12/31/06)	\$ 14,200,000	\$ --
Notes payable, RTFC (b) Dated 11/13/97, variable rate Paid in full 03/01/06	--	194,957
Dated 11/13/97, variable rate Paid in full 03/01/06	--	899,406
Dated 11/13/97, fixed rate Paid in full 03/01/06	--	727,521
Dated 12/31/98, fixed rate Paid in full 03/01/06	--	618,521
Dated 02/13/01, variable rate Paid in full 03/01/06	--	786,457
Dated 02/13/01, variable rate Paid in full 03/01/06	--	932,200
Dated 07/27/01, variable rate Paid in full 03/01/06	--	2,845,311
Lines of Credit, RTFC Line of credit, variable rate (c) Paid in full 03/01/06	--	5,000,000
Line of credit, variable rate (d) Paid in full 03/01/06	--	1,750,000
Line of Credit, Fifth Third Bank (e) Due 03/28/08, variable rate (5.41% at 12/31/06)	--	--
	\$ --	\$ 13,754,373

- (a) On February 28, 2006, the Company borrowed \$14,200,000 to restructure its debt. The note is payable in 10 annual installments of \$1,200,000 for 2007, \$1,400,000 for 2008 through 2012, and \$1,500,000 for 2013 through 2016, with a variable interest rate. The note is collateralized by the assets of the Company.
- (b) The notes payable to Rural Telephone Finance Cooperative (RTFC) were secured by mortgage and security agreements that include substantially all of the assets of the Company. In addition, the Company was required to purchase equity certificates in RTFC equal to 5% of the total amounts borrowed. The notes were payable in quarterly installments over 15 years with interest at variable or fixed rates set by RTFC. The notes were paid in full on March 1, 2006.

NOTES TO FINANCIAL STATEMENTS

Note 3. Long-Term Debt (Continued)

- (c) The line of credit agreement with RTFC provided for borrowings up to \$5,000,000. The agreement carried an interest rate at prime, plus one and one-half percent, was unsecured and was renewed June 28, 2004 for 24 months. The line of credit was paid in full on March 1, 2006.
- (d) The line of credit agreement with RTFC provided for borrowings up to \$2,000,000. The agreement carried an interest rate at prime, plus one and one-half percent, was unsecured and due May 16, 2006. The line of credit was paid in full on March 1, 2006.
- (e) The line of credit agreement with Fifth Third Bank provides for borrowing up to \$3,000,000. The agreement carries a variable interest rate, is secured by certain assets of the company, and is due March 28, 2008.

Approximate maturities or payments required on principal under note payable agreements for each of the succeeding five years are as follows:

Year ending December 31:

2006	\$ 1,200,000
2007	1,400,000
2008	1,400,000
2009	1,400,000
2010	1,400,000

Note 4. Retirement Plans

The Company has a 401(k) plan for qualifying employees who have reached twenty-one years of age. Eligible employees are allowed to invest up to 15% of their compensation and the Company has agreed to match 100% of the first 3% of the employees' contribution and 50% of the employees' contribution between 3% and 5%. The Company contributed \$73,607 and \$67,460 matching funds for its 401(k) plan during the years ended December 31, 2006 and 2005, respectively.

The Company also offers an employer sponsored retirement savings plan for qualified employees who have reached twenty-one years of age. The Company has agreed to contribute 9% of the eligible employee's compensation, plus an additional 5% of the original contribution.

The Company contributed \$259,859 and \$221,669 to its retirement savings plan during the years ended December 31, 2006 and 2005, respectively.

NOTES TO FINANCIAL STATEMENTS

Note 5. Related Party Transactions

The Company shares personnel with one of its members. The Company paid \$114,996 and \$132,681 for shared personnel during the years ended December 31, 2006 and 2005 respectively. The Company also leased offices and warehouse space from two members. The leases are for an unspecified length of time. The monthly lease payments total approximately \$7,000. In addition, the Company incurred interconnection and telephone charges from its members aggregating \$752,095 and \$786,283 for the years ended December 31, 2006 and 2005, respectively.

The Company leases two cellular tower sites from the officers and majority shareholders of a member for \$100 per month for each site. The leases are for an unspecified length of time. In addition, the Company leases two other sites from a company owned by this member for \$600 each on a month to month basis.

The Company leases cellular tower sites from the parent company of one of its other members for \$1,039 per month. The leases are for five years with options to renew.

The Company pays commissions to two of its members for phone sales to customers. The amount of commissions paid to related parties was \$45,484 and \$43,873 for 2006 and 2005 respectively.

Note 6. Operating Leases

The Company has entered into operating leases with its members and other customers to provide fiber optic transmission capacity and ancillary services. The terms of these leases are for 15 years.

Total rental income earned from these operating lease commitments included in the statements of income were \$1,130,809 and \$1,254,902 for the years ended December 31, 2006 and 2005, respectively. Rental income earned from the Company's members from these leases was \$631,789 and \$713,599 for the years ended December 31, 2006 and 2005, respectively.

Investments in operating leases are as follows at December 31:

	2006	2005
Fiber ring	\$ 6,471,128	\$ 6,245,412
Accumulated depreciation	(982,379)	(773,028)
	\$ 5,488,749	\$ 5,472,384

The future minimum rental payments expected to be received under these lease agreements for each of the succeeding five years are approximately \$700,000 each year based upon new contracts negotiated during 2005.

NOTES TO FINANCIAL STATEMENTS

Note 6. Operating Leases (Continued)

The Company has also entered into lease agreements with its members to obtain fiber optic transmission and digital microwave transmission services. The terms of these leases are for 15 years.

Rental expenses incurred under these operating lease commitments included in the statements of income were \$194,083 and \$33,329 for the years ended December 31, 2006 and 2005, respectively. The future minimum lease payments required under these lease agreements for each of the succeeding five years are \$115,734 each year.

Note 7. Eligible Telecommunication Carrier

During the prior year, the Company was granted Eligible Telecommunication Carrier (ETC) status by the Kentucky Public Service Commission. As an ETC, the Company receives funding from the federal Universal Service Fund (USF) to support the high cost of providing local telephone service in rural areas. USF payments amounted to \$3,716,602 and \$589,913 for 2006 and 2005 respectively.

Note 8. Impairment of Goodwill

During 2005, the Company completed its annual valuation of the acquired goodwill related to paging acquisitions. Pursuant to the valuation, the Company expensed the remaining balance of goodwill. In management's judgment, the underlying assets associated with the goodwill were determined to be of substantially less value than the amount originally paid. The Company disputed the amount based upon the estimated current market value of the purchased customer lists, which approximates the current amortized book value. Accordingly, the entire balance of the remaining note payable issued as part of the acquisitions, along with the related accrued interest, has been written off due to the impairment of goodwill.

The following is a summary of the impairment of goodwill expense included in the financial statements for the year ended December 31, 2005:

Goodwill	\$ 787,286
Note payable	(400,000)
Accrued interest	(56,000)
	<u>\$ 331,286</u>

DIRECTIONS TO WRIGLEY TOWER
MORGAN COUNTY KENTUCKY

Starting in front of the Morgan County Courthouse, West Liberty, Kentucky on U S Route 460 going North.

Follow Rt. 460 a distance of one tenth (.1) mile to the junction of Rt. 460 and Route 7.

Take Route 7 North and follow it for a distance of 10.8 miles.

Turn right onto a gravel road and follow that road to the tower site, a distance of .7 tenths miles.

Total distance is 11.6 miles.

Directions provided by;

Dennis Shepherd
Thacker-Grigsby Telephone Co.
P O BOX 789
Hindman, Kentucky 41822

Phone; 606-785-2215
Cell Phone; 606-791-6263

Search Area Map

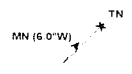
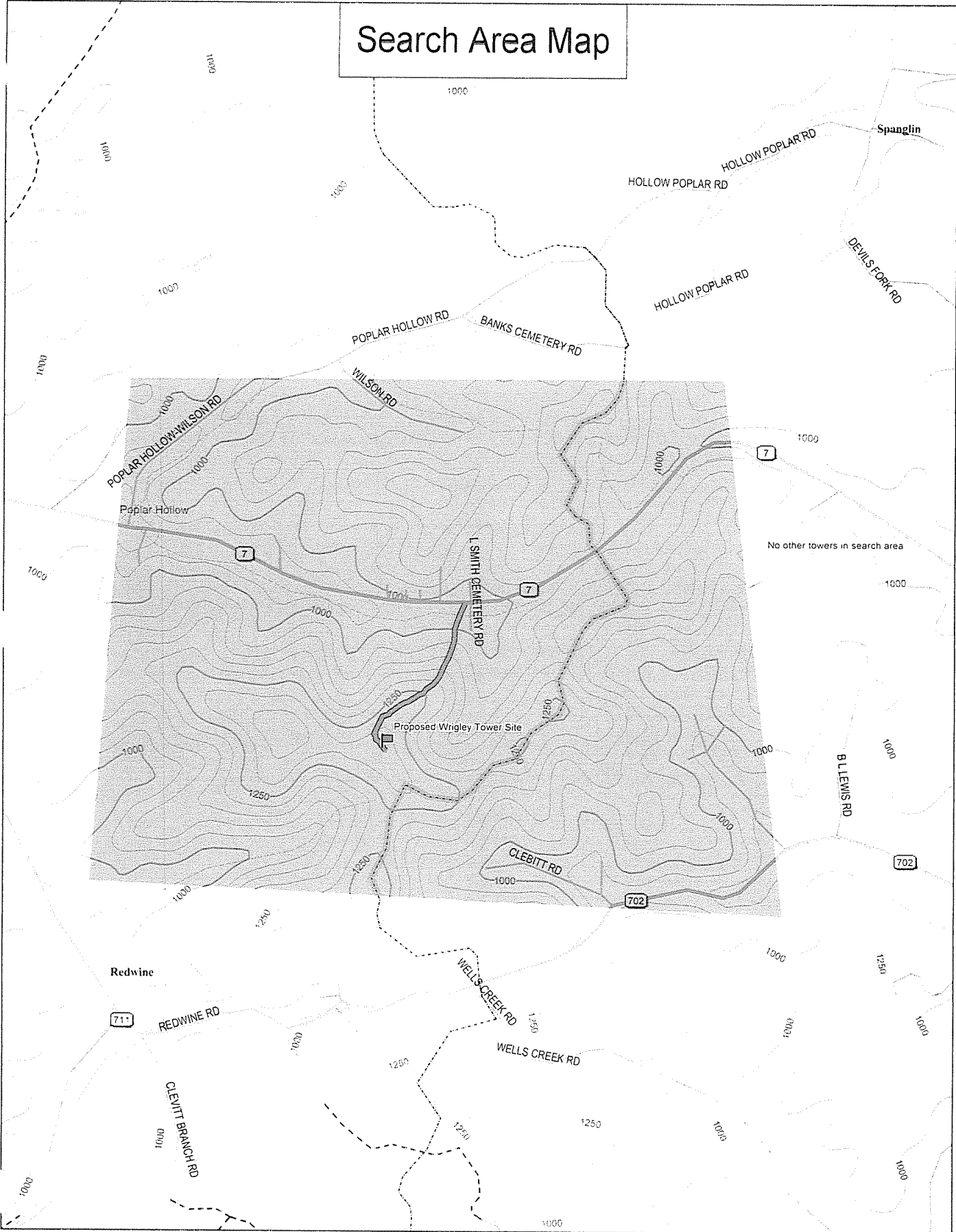

JUN 12 2007
TIME: 3:00pm
RANDY WILLIAMS, CLERK

DEED OF CONVEYANCE

THIS DEED OF CONVEYANCE, entered into this 1st day of June, 2007,
between **Emory Cecil Smith and Lois Smith, married, Grantors**, of 12154 Highway
7, West Liberty, Kentucky 41472, and **East Kentucky Network, LLC**, d/b/a
Appalachian Wireless, 101 Technology Trail, Ivel, Kentucky 41642, **Grantee:**

WITNESSETH:

That said Grantors for and in consideration of the sum of Ten Thousand Dollars
(\$10,000.00), cash in hand paid, the receipt and sufficiency of which is hereby
acknowledged, do hereby grant, sell and convey to the Grantee, its successors and assigns,
the following described property, to-wit:

BEING a part of the same property conveyed from Hannah
Smith, widow to Emory Cecil Smith dated October 13, 1987 of
record in Deed Book 145, Page 738, Morgan County Clerk's
Office.

BEING the same property described by metes and bounds in
the description attached hereto and made a part hereof as
Exhibit "A", and as shown on the plat dated 3rd day of
May, 2007, prepared by Randal Coteman,
Licensed Land Surveyor, and attached hereto and made a part
hereof as Exhibit "B."

Grantors grant and convey unto Grantee, its successors or assigns, a permanent
easement and right of way for a roadway of sufficient width for ingress and egress with men,
vehicles, equipment and machinery over and across Grantors' retained surface property to
the tract or parcel of land granted and conveyed herein to Grantee, its successors and
assigns together with the right to reconstruct or use any existing roadways over Grantors'
retained surface for such purposes.

Grantors grant and convey unto Grantee, its successors or assigns, an easement and
right of way to construct and maintain any and all power lines, telephone lines, co-axial

lines or any other utilities or related facilities needed and/or necessary for use by Grantee, its successors or assigns, over and across Grantors' retained surface property to the tract or parcel of land granted and conveyed herein to Grantee, its successor and assigns.

Grantors further grant and convey unto Grantee, its successors and assigns, the right to remove any trees, tree limbs, undergrowth or obstructions upon Grantors' retained surface property that might interfere with or damage any towers or structures that Grantee, its successors or assigns, may place upon the above described tract of land, or with the easements and rights of way granted herein.

TO HAVE AND TO HOLD the same with all appurtenances thereunto belonging unto the Grantee, its successors and assigns forever, with covenant of General Warranty.

We, the undersigned, do hereby certify and swear pursuant to KRS Chapter 382, that the full and complete consideration paid for the transfer of the hereinabove described property was Ten Thousand Dollars (\$10,000.00).

IN TESTIMONY WHEREOF, the parties have hereunto subscribed their names, this day and year aforesaid.

GRANTORS:

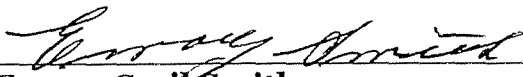

Emory Cecil Smith

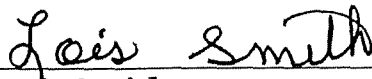

Lois Smith

GRANTEE:

**EAST KENTUCKY NETWORK, LLC
d/b/a APPALACHIAN WIRELESS**

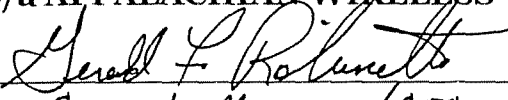
BY: 

ITS: General Manager / CEO

STATE OF KENTUCKY

COUNTY OF Morgan

I, Dennis Shepherd, a Notary Public in and for the County and State aforesaid, do hereby certify that the foregoing Deed of Conveyance and Consideration Certificate was this day produced, acknowledged, subscribed and sworn before me in the said County and State and signed by **Emory Cecil Smith and Lois Smith, Grantors**, this 1st day of June, 2007.

Dennis Shepherd
NOTARY PUBLIC
Commission Expires: oct. 22-2009

STATE OF KENTUCKY

COUNTY OF Floyd

I, Teresa M. Apel, a Notary Public in and for the county and state aforesaid, do hereby certify that the foregoing Deed of Conveyance and Consideration Certificate was this day produced, acknowledged, subscribe and sworn to before me in said County and State and signed by **East Kentucky Network, LLC, d/b/a Appalachian Wireless**, by Gerald F. Robinette, its General Manager/CEO, this 4th day of June, 2007.



Teresa M. Apel
NOTARY PUBLIC
Commission Expires: June 22, 2009

This is to certify that this instrument was prepared by:

William S. Kendrick
WILLIAM S. KENDRICK, ATTORNEY
FRANCIS, KENDRICK & FRANCIS
P.O. Box 268
Prestonsburg, Kentucky 41653
606/886-2812

STATE OF KENTUCKY
COUNTY OF MORGAN

**Clerk's Certificate of
Lodgment and Record**

I, _____, Clerk of the County for the County and State aforesaid, certify that the foregoing Deed was on the ____ day of _____, 2007 lodged for record, whereupon the same, with the foregoing and this certificate have been duly recorded in my office.

WITNESS my hand, this ____ day of _____, 2007.

_____ Clerk

By _____ D.C.

Emory Cecil Smith

LOT #1

Lying and being on Road Fork in Morgan County near Redwine and bounded as follows:

Beginning on a #5 rebar (found/cap #2735-2652) at the base of a dead marked 20" chestnut oak, said point being the Northwest corner of the Maurice Newsom tract and also a corner to Mike Ross Inc., and also a corner to Gary Bishop and being on the top of the ridge between Road Fork and the North Fork of the Licking River, thence with Bishop's line down the center of the point, NE 01°07'42", 74.91' to a #4 rebar (set/cap#2437) at the base of a 20" chestnut oak in the old fence line, thence NW 13°32'48", 89.37' to a #4 rebar (set/cap#2437) at the base of a 24" chestnut oak in the old fence line and the line of Emory Cecil Smith, thence down the hill with said Smith's line, NE 88°32'52", 189.66' to a #4 rebar (set/cap#2437), thence up the hill SW 24°26'32", 104.40' to a #4 rebar (set/cap#2437), thence SW 24°26'32", 62.13' to a #4 rebar (set/cap#2437) at the base of a 16" White Oak in the old fence line on the top of the ridge, witness a found GPS point SE 70°30'03", 5.12' (Coordinates N:2268430.56, E:2367345.22, el: 1339.33'), thence with the top of the ridge SW 81°34'55", 102.34' to the beginning containing 0.50 acres.

 5/31/7
Randall L. Coleman PLS #2437 Date

"Exhibit A"

STATE OF KENTUCKY
COUNTY OF MORGAN

I, Randy Williams, Clerk Morgan County for the county and state aforesaid do hereby certify that the foregoing Deed was on the 10 day of June, 2009 lodged for record, whereupon the foregoing and this certificate have been duly recorded in my office. Given under my hand this the 14 day of June, 2009.

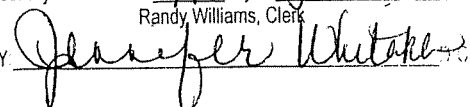
Randy Williams, Clerk
BY: 

APPALACHIAN WIRELESS

101 TECHNOLOGY TRAIL
IVEL, KY. 41642

PROPOSED TOWER SITE

EMORY SMITH TR. WRIGLEY IN MORGAN CO

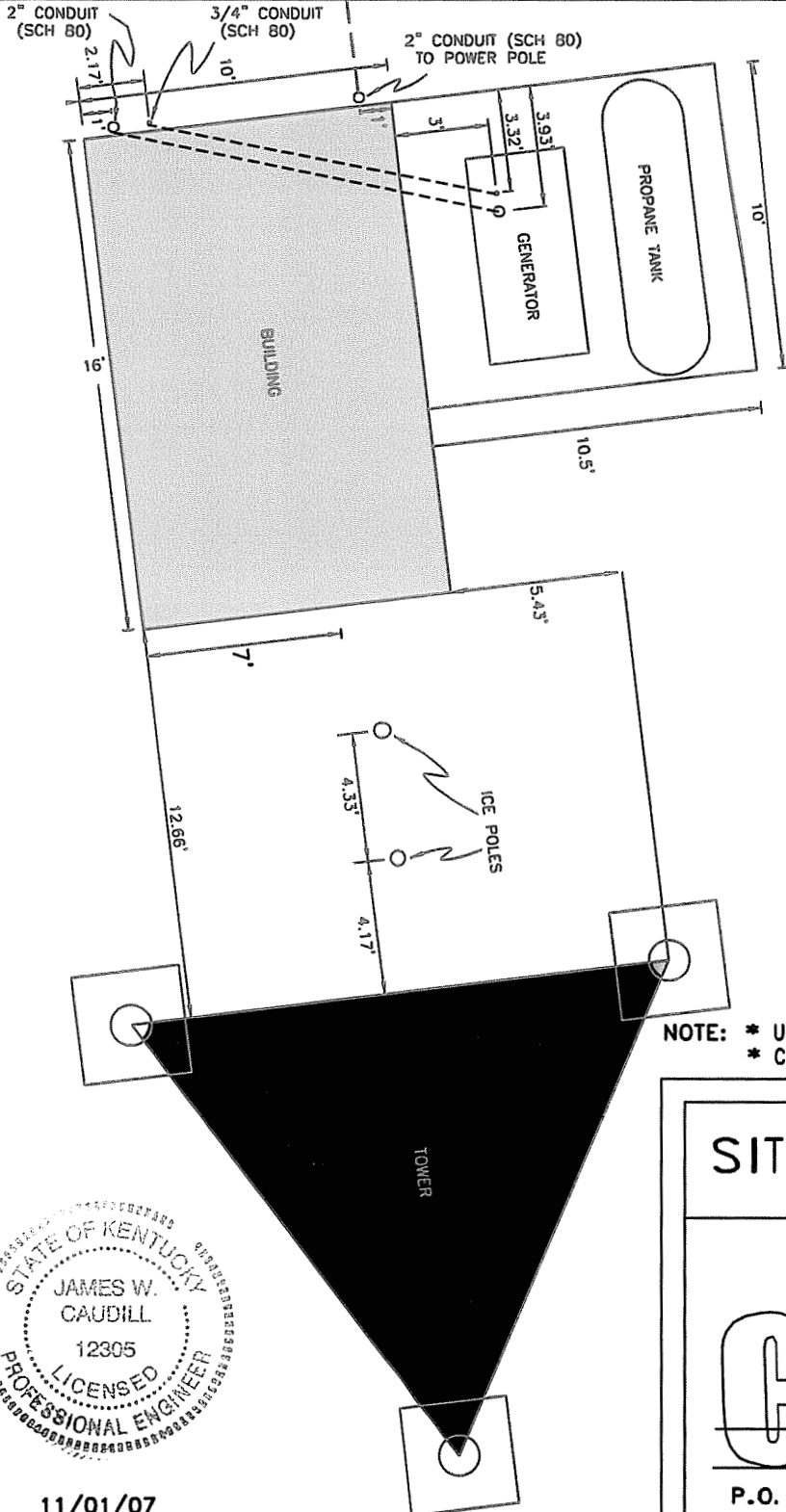

DETAIL 'A'

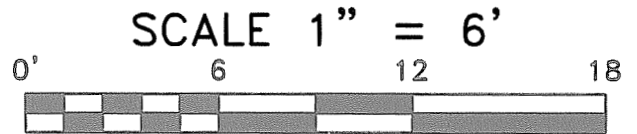

NOTE: * USE SWEEPS IN CONDUIT FOR ALL TURNS
* CONDUITS SHALL BE PLACED 3.25" OUTSIDE CONCRETE SLAB

SITE SURVEY/STR LOCATION

COLEMAN
ENGINEERING



P.O. BOX 153, HINDMAN, KY 41822

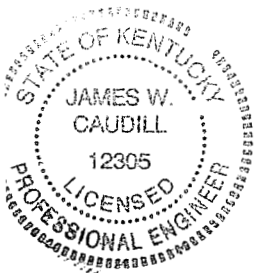

11/01/07