

AGREEMENT

between

BellSouth Telecommunications, Inc.

and

Interprise America

Effective Date: September 15, 1997

KENTUCKY

TABLE OF CONTENTS

<u>SECTION</u>	<u>PAGE</u>
AGREEMENT.....	1
PREFACE	1
RECITALS.....	1
DEFINITIONS AND ACRONYMS	2
GENERAL TERMS AND CONDITIONS.....	2
1. Provision of Local Service and Unbundled Network Elements	2
2. Term of Agreement.....	4
3. Termination of Agreement; Transitional Support	4
4. Good Faith Performance.....	5
5. Option to Obtain Services and Elements Under Other Agreements	6
6. Responsibility of Each Party	5
7. Governmental Compliance	6
8. Responsibility For Environmental Contamination	8
9. Regulatory Matters.....	7
10. Liability and Indemnity	8
11. Audits and Inspections.....	12
12. Performance Measurement	14
13. Force Majeure.....	13

14. Certain Federal, State and Local Taxes	15
15. Dispute Resolution.....	17
16. Notices	19
17. Confidentiality and Proprietary Information.....	20
18. Branding.....	20
19. Directory Listings Requirements	20
20. Subscriber List Information/Local Number Portability	22
21. DELETED	26
22. Miscellaneous	26
 PART I: LOCAL SERVICES RESALE.....	 30
23. Telecommunications Services Provided for Resale.....	30
24. General Terms and Conditions for Resale.....	31
25. Requirements for Specific Services	33
26. DELETED	39
27. Support Functions.....	40
28. Service Functions	43
 PART II: UNBUNDLED NETWORK ELEMENTS	 52
29. Introduction	52
30. Unbundled Network Elements	52
 PART III: ANCILLARY FUNCTIONS.....	 53
31. Introduction	53

32. BellSouth Provision of Ancillary Functions.....	53
33. Standards for Ancillary Functions	53
PART IV: PRICING	55
34. General Principles.....	55
35. Local Service Resale	57
36. Unbundled Network Elements	57
37. Compensation For Call and Transport Termination.....	57
38. Ancillary Functions.....	57
39. Local Number Portability.....	58
40. Recorded Usage Data	58
41. ELECTRONIC INTERFACES	58
42. TRUE-UP	58

ATTACHMENTS

Attachment 1	Left Blank Intentionally
Attachment 2	Services Description: Unbundled Network Elements
Attachment 3	Service Description: Ancillary Functions
Attachment 4	Provisioning and Ordering
Attachment 5	Maintenance
Attachment 6	Connectivity Billing and Recording
Attachment 7	Provision of Customer Usage Data
Attachment 8	Local Number Portability
Attachment 9	Network Security
Attachment 10	Acronyms
Attachment 11	Definitions
Attachment 12	Left Blank Intentionally
Attachment 13	BAPCO Agreement
Attachment 14	Bona Fide Request Process
Attachment 15	Interface Requirements for Ordering and Provisioning, Maintenance and Repair, and Pre-Ordering

AGREEMENT

PREFACE

This Agreement, which shall become effective as of the 15th day of September 1997, is entered into by and between U S WEST Interprise America, Inc. d/b/a !NTERPRISE America ("!nterprise America"), a Colorado corporation, having an office at 1801 California Street, Suite 5200, Denver, Colorado 80202, on behalf of itself, and BellSouth Telecommunications, Inc. ("BellSouth"), a Georgia corporation, having an office at 675 West Peachtree Street, Atlanta, Georgia 30375, on behalf of itself and its successors and assigns.

RECITALS

WHEREAS, The Telecommunications Act of 1996 (the "Act") was signed into law on February 8, 1996; and

WHEREAS, the Act places certain duties and obligations upon, and grants certain rights to Telecommunications Carriers; and

WHEREAS, BellSouth is an Incumbent Local Exchange Carrier; and

WHEREAS, BellSouth is willing to provide Telecommunications Services for resale, Interconnection, Unbundled Network Elements and Ancillary Functions which include, but are not limited to, access to poles, ducts, conduits and rights-of-way, and collocation of equipment at BellSouth's Premises on the terms and subject to the conditions of this Agreement; and

WHEREAS, !nterprise America is a Telecommunications Carrier and has requested that BellSouth negotiate an Agreement with !nterprise America for the provision of Interconnection, Unbundled Network Elements, and Ancillary Functions as well as Telecommunications Services for resale, pursuant to the Act and in conformance with BellSouth's duties under the Act,

NOW, THEREFORE, in consideration of the promises and the mutual covenants of this Agreement, !nterprise America and BellSouth hereby agree as follows:

DEFINITIONS AND ACRONYMS

For purposes of this Agreement, certain terms have been defined in Attachment 11 and elsewhere in this Agreement to encompass meanings that may differ from, or be in addition to, the normal connotation of the defined word. Unless the context clearly indicates otherwise, any term defined or used in the singular shall include the plural. The words "shall" and "will" are used interchangeably throughout this Agreement and the use of either connotes a mandatory requirement. The use of one or the other shall not mean a different degree of right or obligation for either Party. A defined word intended to convey its special meaning is capitalized when used. Other terms that are capitalized, and not defined in this Agreement, shall have the meaning in the Act. For convenience of reference, Attachment 10 provides a list of acronyms used throughout this Agreement.

GENERAL TERMS AND CONDITIONS

1. Provision of Local Service and Unbundled Network Elements

This Agreement and its attachments set forth the terms, conditions and prices under which BellSouth agrees to provide (a) Telecommunications Service that BellSouth currently provides, or may offer hereafter for resale along with the Support Functions and Service Functions set forth in this Agreement (hereinafter collectively referred to as "Local Services") and (b) certain unbundled Network Elements, and (c) Ancillary Functions to Interprise America (Local Services, Network Elements, and Ancillary Functions, collectively referred to as "Services and Elements"). This Agreement also sets forth the terms and conditions for the interconnection of Interprise America's network to BellSouth's network and the mutual and reciprocal compensation for the transport and termination of telecommunications traffic. BellSouth may fulfill the requirements imposed upon it by this Agreement by itself or, in the case of directory listings for white pages may cause BellSouth Advertising and Publishing Company ("BAPCO") to take such actions to fulfill BellSouth's responsibilities. This Agreement includes Parts I through IV, and their Attachments 1 - 15 and all accompanying Appendices and Exhibits. Unless otherwise provided in this Agreement, BellSouth will perform all of its obligations hereunder throughout its entire service area. The Parties further agree to comply with all provisions of the Act, including Section 271(e) (1).

- 1.A The Local Services provided pursuant to this Agreement may be connected to or purchased in conjunction with other Local Service provided by BellSouth or to any Services or Elements provided by Interprise America itself or any other vendor. Interprise America may purchase unbundled Network Elements for the purpose of Interprise America combining said Network Elements, whether those Network Elements are to be combined by Interprise America with Interprise America's own Network Elements or are to be combined by Interprise America with other Network Elements purchased from BellSouth. Interprise America may utilize and combine such Network Elements in any manner that it chooses, including but not limited to, providing telecommunications services completely through access to the Network Elements of BellSouth's network. Notwithstanding the foregoing, should Interprise America utilize Network Elements to provide the same telecommunications services to an existing BellSouth customer, the charges for such Network Elements shall be the retail service charges for the service provided by BellSouth less the resale discount set forth in Section 35 of this Agreement.
- 1.1 Subject to the requirements of this Agreement, Interprise America may, at any time add, relocate or modify any Services and Elements purchased hereunder. Requests for additions or other changes shall be handled pursuant to the Bona Fide Request Process provided in Attachment 14. Termination of any Services or Elements shall be handled pursuant to Section 3.1 of the General Terms and Conditions of this Agreement.
- 1.2 BellSouth shall not discontinue any Network Element, Ancillary Function, or Combination provided hereunder without the prior written consent of Interprise America. Such consent shall not be unreasonably withheld. BellSouth shall not discontinue any Local Service provided hereunder unless BellSouth provides Interprise America prior written notice as stated in Section 24.3.2.1 of intent to discontinue any such service. BellSouth agrees to make any such service available to Interprise America for resale to Interprise America's Customers who are subscribers of such services from Interprise America until the date BellSouth discontinues any such service for BellSouth's Customers. BellSouth also agrees to adopt a reasonable, nondiscriminatory transition schedule for BellSouth or Interprise America Customers who may be purchasing any such service.

2. **Term of Agreement**

2.1 When executed by authorized representatives of BellSouth and Interprise America, this Agreement shall become effective as of the Effective Date stated above, and shall expire three (3) years from the Effective Date unless terminated in accordance with the provisions of Section 3.2 of the General Terms and Conditions.

2.2 Assuming both parties desire a Follow-on Agreement, no later than one hundred and eighty (180) days prior to the expiration of this Agreement, the Parties agree to commence negotiations with regard to the terms, conditions and prices of a Follow-on Agreement for the provision of Services and Elements to be effective on or before the expiration date of this Agreement ("Follow-on Agreement"). The Parties further agree that any such Follow-on Agreement shall be for a term of no less than three (3) years unless the Parties agree otherwise.

2.3 If, within one hundred and thirty-five (135) days of commencing the negotiation referenced to Section 2.2, above, the Parties are unable to satisfactorily negotiate new terms, conditions and prices, either Party may petition the Commission to establish an appropriate Follow-on Agreement pursuant to 47 U.S.C. § 252. The Parties agree that in such event they shall encourage the Commission to issue its order regarding such Follow-on Agreement no later than the expiration date of this Agreement. The Parties further agree that in the event the Commission does not issue its order by the expiration date of this Agreement, or if the Parties continue beyond the expiration date of this Agreement to negotiate without Commission intervention, the terms, conditions and prices ultimately ordered by the Commission, or negotiated by the Parties, will be effective, retroactive to the day following the expiration date of this Agreement. Until the desired Follow-on Agreement becomes effective, BellSouth shall provide Services and Elements pursuant to the terms, conditions and prices of this Agreement that are then in effect. Prior to filing a Petition pursuant to this Section 2.3, the Parties agree to utilize the dispute resolution process provided in Section 15 of the General Terms and Conditions of this Agreement.

3. **Termination of Agreement; Transitional Support**

3.1 Interprise America may terminate any Local Service(s), Network Element(s), Combination(s), or Ancillary Function(s) provided under this Agreement upon thirty (30) days written notice to BellSouth unless a different notice period or different conditions are specified for termination of such Local Services(s), Network Element(s), or Combination(s) in this Agreement or pursuant to any applicable tariff, in which event such specific period or conditions shall apply, provided such period or condition is reasonable, nondiscriminatory and narrowly tailored. Where there is no

such different notice period or different condition specified, Interprise America's liability shall be limited to payment of the amounts due for any terminated Local Service(s), Network Element(s), Combination(s) or Ancillary Service provided up to and including the date of termination. Notwithstanding termination, the provisions of Section 10, infra, shall still apply. Upon termination, BellSouth agrees to cooperate in an orderly and efficient transition to Interprise America or another vendor such that the level and quality of the Services and Elements is not degraded and to exercise its best efforts to effect an orderly and efficient transition. Interprise America agrees that it may not terminate the entire Agreement pursuant to this section.

- 3.2 If a Party is in breach of a material term or condition of this Agreement ("Defaulting Party"), the other Party shall provide written notice of such breach to the Defaulting Party. The defaulting party shall have at least ten (10) business days, or as otherwise mutually agreed, from receipt of notice to cure the breach. If the breach is not cured, the Parties shall follow the dispute resolution procedure of Section 15 of the General Terms and Conditions of this Agreement.

4. **Good Faith Performance**

In the performance of their obligations under this Agreement, the Parties shall act in good faith and consistently with the intent of the Act. Where notice, approval or similar action by a Party is permitted or required by any provision of this Agreement, (including, without limitation, the obligation of the Parties to further negotiate the resolution of new or open issues under this Agreement) such action shall not be unreasonably delayed, withheld or conditioned.

5. **Option to Obtain Services and Elements Under Other Agreements**

If as a result of any proceeding or filing before any Court, state commission or the Federal Communications Commission, voluntary agreement or arbitration proceeding pursuant to the Act or pursuant to any applicable state law, BellSouth becomes obligated to provide Services and Elements, whether presently covered by this Agreement, to a third Party at rates or on terms and conditions different than the provisions of this Agreement, Interprise America shall have the option to substitute the third Party's interconnection agreement in its entirety for this Agreement and this Agreement shall thereupon become null and void. The substituted agreement shall apply to the same states as such other agreement and for the identical term.

6. **Responsibility of Each Party**

Each Party is an independent contractor, and has and hereby retains the right to exercise full control of and supervision over its own performance of its obligations under this Agreement and retains full control over the employment, direction, compensation and discharge of all employees assisting in the performance of such obligations. Each Party will be solely responsible for all matters relating to payment of such employees, including compliance with social security taxes, withholding taxes and all other regulations governing such matters. Each Party will be solely responsible for proper handling, storage, transport and disposal at its own expense of all (i) substances or materials that it or its contractors or agents bring to, create or assume control over at Work Locations or, (ii) waste resulting therefrom or otherwise generated in connection with its or its contractors' or agents' activities at the Work Locations. Subject to the limitations on liability and except as otherwise provided in this Agreement, each Party shall be responsible for (i) its own acts and performance of all obligations imposed by Applicable Law in connection with its activities, legal status and property, real or personal and, (ii) the acts of its own affiliates, employees, agents and contractors during the performance of that Party's obligations hereunder.

7. **Governmental Compliance**

7.1 Interprise America and BellSouth each shall comply at its own expense with all Applicable Law that relates to (i) its obligations under or activities in connection with this Agreement or (ii) its activities undertaken at, in connection with or relating to Work Locations. Interprise America and BellSouth each agree to indemnify, defend (at the other Party's request) and save harmless the other, each of its officers, directors and employees from and against any losses, damages, claims, demands, suits, liabilities, fines, penalties and expenses (including reasonable attorneys' fees) that arise out of or result from (i) its failure or the failure of its contractors or agents to so comply or (ii) any activity, duty or status of it or its contractors or agents that triggers any legal obligation to investigate or remediate environmental contamination. BellSouth, at its own expense, will be solely responsible for obtaining from governmental authorities, building owners, other carriers, and any other persons or entities, all rights and privileges (including, but not limited to, space and power), which are necessary for BellSouth to provide the Services and Elements pursuant to this Agreement. Interprise America, at its own expense, will be solely responsible for obtaining from governmental authorities, building owners, other carriers, and any other persons or entities, all rights and privileges which are Interprise America's obligation as a provider of telecommunications services to its Customers pursuant to this Agreement.

7.2 BellSouth shall accept orders for Service and Elements in accordance with the Federal Communications Commission Rules or State Commission Rules.

8. **Responsibility For Environmental Contamination**

8.1 Interprise America shall in no event be liable to BellSouth for any costs whatsoever resulting from the presence or Release of any Environmental Hazard or Hazardous Materials that Interprise America did not introduce to the affected Work Location so long as Interprise America's actions do not cause or substantially contribute to the release of any Environmental Hazard or Hazardous Materials. BellSouth shall indemnify, defend (at Interprise America's request) and hold harmless Interprise America, each of its officers, directors and employees from and against any losses, damages, claims, demands, suits, liabilities, fines, penalties and expenses (including reasonable attorneys' fees) that arise out of or result from (i) any Environmental Hazard or Hazardous Materials that BellSouth, its contractors or agents introduce to the Work Locations or (ii) the presence or Release of any Environmental Hazard or Hazardous Materials for which BellSouth is responsible under Applicable Law, to the extent the release of any Environmental Hazard or Hazardous Materials is not caused or substantially contributed to by Interprise America's actions.

8.2 BellSouth shall in no event be liable to Interprise America for any costs whatsoever resulting from the presence or Release of any Environmental Hazard or Hazardous Materials that BellSouth did not introduce to the affected Work Location, so long as BellSouth's actions do not cause or substantially contribute to the Release of any Environmental Hazards or Hazardous Materials. Interprise America shall indemnify, defend (at BellSouth's request) and hold harmless BellSouth, each of its officers, directors and employees from and against any losses, damages, claims, demands, suits, liabilities, fines, penalties and expenses (including reasonable attorneys' fees) that arise out of or result from (i) any Environmental Hazard or Hazardous Materials that Interprise America, its contractors or agents introduce to the Work Locations or (ii) the presence or Release of any Environmental Hazard or Hazardous Materials for which Interprise America is responsible under Applicable Law, to the extent the release of any Environmental Hazard or Hazardous Materials is not caused or substantially contributed to by BellSouth's actions.

9. **Regulatory Matters**

9.1 BellSouth shall be responsible for obtaining and keeping in effect all Federal Communications Commission, State Commissions, franchise authority and other regulatory approvals that may be required in connection with the performance of its obligations under this Agreement. Interprise America shall be responsible for obtaining and keeping in effect all Federal Communications Commission, state regulatory Commission, franchise authority and other regulatory approvals that may be required in connection with its offering of services to Interprise America Customers contemplated by this Agreement. Interprise America shall reasonably

cooperate with BellSouth in obtaining and maintaining any required approvals for which BellSouth is responsible, and BellSouth shall reasonably cooperate with Interprise America in obtaining and maintaining any required approvals for which Interprise America is responsible.

- 9.2 In the event that BellSouth is required by any governmental authority to file a tariff or make another similar filing (“Filing”) in order to implement this Agreement, BellSouth shall (i) consult with Interprise America reasonably in advance of such Filing about the form and substance of such Filing, (ii) provide to Interprise America its proposed tariff and obtain Interprise America's agreement on the form and substance of such Filing, and (iii) take all steps reasonably necessary to ensure that such Filing imposes obligations upon BellSouth that are no less favorable than those provided in this Agreement and preserves for Interprise America the full benefit of the rights otherwise provided in this Agreement. In no event shall BellSouth file any tariff to implement this Agreement that purports to govern Services and Elements that is inconsistent with the rates and other terms and conditions set forth in this Agreement unless such rate or other terms and conditions are more favorable than those set forth in this Agreement.
- 9.3 In the event that any final and nonappealable legislative, regulatory, judicial or other legal action materially affects any material terms of this Agreement, or the ability of Interprise America or BellSouth to perform any material terms of this Agreement, Interprise America or BellSouth may, on thirty (30) days' written notice (delivered not later than thirty (30) days following the date on which such action has become legally binding and has otherwise become final and nonappealable) require that such terms be renegotiated, and the Parties shall renegotiate in good faith such mutually acceptable new terms as may be required. In the event that such new terms are not renegotiated within ninety (90) days after such notice, the Dispute shall be resolved pursuant to Section 15 of the General Terms and Conditions of this Agreement.

10. **Liability and Indemnity**

- 10.1 **Liabilities of BellSouth** - Unless expressly stated otherwise in this Agreement, the liability of BellSouth to Interprise America during any contract year resulting from any and all causes shall not exceed the amounts owing Interprise America during the contract year in which such cause arises or accrues.
- 10.2 **Liabilities of Interprise America** - Unless expressly stated otherwise in this Agreement, the liability of Interprise America to BellSouth during any contract year resulting from any and all causes shall not exceed the amounts owing BellSouth during the contract year in which such cause arises or accrues.

- 10.3 Each Party shall, to the greatest extent permitted by Applicable Law, include in its local switched service tariff (if it files one in a particular state) or in any state where it does not file a local service tariff, in an appropriate contract with its customers that relates to the Services and Elements provided under this Agreement, a limitation of liability (i) that covers the other Party to the same extent the first Party covers itself and (ii) that limits the amount of damages a customer may recover to the amount charged the applicable customer for the service that gave rise to such loss.
- 10.4 **No Consequential Damages** - Neither Interprise America nor BellSouth shall be liable to the other Party for any indirect, incidental, consequential, reliance, or special damages suffered by such other Party (including without limitation damages for harm to business, lost revenues, lost savings, or lost profits suffered by such other parties (collectively, "Consequential Damages")), regardless of the form of action, whether in contract, warranty, strict liability, or tort, including without limitation negligence of any kind whether active or passive, and regardless of whether the parties knew of the possibility that such damages could result. Each Party hereby releases the other Party and such other Party's subsidiaries and affiliates, and their respective officers, directors, employees and agents from any such claim for consequential damages. Nothing contained in this section 10 shall limit BellSouth's or Interprise America's liability to the other for actual damages resulting from (i) willful or intentional misconduct (including gross negligence); (ii) bodily injury, death or damage to tangible real or tangible personal property proximately caused by BellSouth's or Interprise America's negligent act or omission or that of their respective agents, subcontractors or employees, nor shall anything contained in this Section 10 limit the parties' indemnification obligations as specified herein.
- 10.5 **Obligation to Indemnify and Defend** - Each Party shall, and hereby agrees to, defend at the other's request, indemnify and hold harmless the other Party and each of its officers, directors, employees and agents (each, an "Indemnitee") against and in respect of any loss, debt, liability, damage, obligation, claim, demand, judgment or settlement of any nature or kind, known or unknown, liquidated or unliquidated, including without limitation all reasonable costs and expenses incurred (legal, accounting or otherwise) (collectively, "Damages") arising out of, resulting from or based upon any pending or threatened claim, action, proceeding or suit by any third Party (a "Claim") (i) alleging any breach of any representation, warranty or covenant made by such indemnifying Party (the "Indemnifying Party") in this Agreement, (ii) based upon injuries or damage to any person or property or the environment arising out of or in connection with this Agreement that are the result of the Indemnifying Party's actions, breach of Applicable Law, or status of its employees, agents and subcontractors, or (iii) for actual or alleged infringement of any patent,

copyright, trademark, service mark, trade name, trade dress, trade secret or any other intellectual property right, now known or later developed (referred to as "Intellectual Property Rights") to the extent that such claim or action arises from Interprise America or Interprise America's Customer's use of the Services and Elements provided under this Agreement.

10.6

Defense; Notice; Cooperation - Whenever a Claim shall arise for indemnification under this Section 10, the relevant Indemnitee, as appropriate, shall promptly notify the Indemnifying Party and request the Indemnifying Party to defend the same. Failure to so notify the Indemnifying Party shall not relieve the Indemnifying Party of any liability that the Indemnifying Party might have, except to the extent that such failure prejudices the Indemnifying Party's ability to defend such Claim. The Indemnifying Party shall have the right to defend against such liability or assertion in which event the Indemnifying Party shall give written notice to the Indemnitee of acceptance of the defense of such Claim and the identity of counsel selected by the Indemnifying Party. Except as set forth below, such notice to the relevant Indemnitee shall give the Indemnifying Party full authority to defend, adjust, compromise or settle such Claim with respect to which such notice shall have been given, except to the extent that any compromise or settlement shall prejudice the Intellectual Property Rights of the relevant Indemnitees. The Indemnifying Party shall consult with the relevant Indemnitee prior to any compromise or settlement that would affect the Intellectual Property Rights or other rights of any Indemnitee, and the relevant Indemnitee shall have the right to refuse such compromise or settlement and, at the refusing Party's or refusing Parties' cost, to take over such defense, provided that in such event the Indemnifying Party shall not be responsible for, nor shall it be obligated to indemnify the relevant Indemnitee against, any cost or liability in excess of such refused compromise or settlement. With respect to any defense accepted by the Indemnifying Party, the relevant Indemnitee shall be entitled to participate with the Indemnifying Party in such defense if the Claim requests equitable relief or other relief that could affect the rights of the Indemnitee and also shall be entitled to employ separate counsel for such defense at such Indemnitee's expense. In the event the Indemnifying Party does not accept the defense of any indemnified Claim as provided above, the relevant Indemnitee shall have the right to employ counsel for such defense at the expense of the Indemnifying Party. Each Party agrees to cooperate and to cause its employees and agents to cooperate with the other Party in the defense of any such Claim and the relevant records of each Party shall be available to the other Party with respect to any such defense.

11.

Audits and Inspections

- 11.1 For carrier billing purposes, the Parties have agreed, pursuant to Section 12 of Attachment 6, to create a process for pre-bill certification, which includes audit procedures. Until such time as that process is in place, the audit process provided in Section 11.1 shall apply.
- 11.1.1 Subject to BellSouth's reasonable security requirements and except as may be otherwise specifically provided in this Agreement, Interprise America may audit BellSouth's books, records and other documents once in each Contract Year for the purpose of evaluating the accuracy of BellSouth's billing and invoicing. Such audit may include examination of the flow of call detail records from BellSouth's switch to BellSouth's internal systems to the usage file transmitted to Interprise America. Interprise America may employ other persons or firms for this purpose. Such audit shall take place at a time and place agreed on by the Parties no later than thirty (30) days after notice thereof to BellSouth.
- 11.1.2 BellSouth shall promptly correct any billing error that is revealed in an audit, including making refund of any overpayment by Interprise America in the form of a credit on the invoice for the first full billing cycle after the Parties have agreed upon the accuracy of the audit results. Any Disputes concerning audit results shall be resolved pursuant to the procedures described in Section 15 of the General Terms and Conditions of this Agreement.
- 11.1.3 BellSouth shall cooperate fully in any such audit, providing reasonable access to any and all appropriate BellSouth employees and books, records and other documents reasonably necessary to assess the accuracy of BellSouth's bills.
- 11.1.4 Interprise America may audit BellSouth's books, records and documents more than once during any Contract Year if the previous audit found previously uncorrected net variances or errors in invoices in BellSouth's favor with an aggregate value of at least two percent (2%) of the amounts payable by Interprise America for Services and Elements or Combinations provided during the period covered by the audit.
- 11.1.5 Audits shall be at Interprise America's expense, subject to reimbursement by BellSouth in the event that an audit finds an adjustment in the charges or in any invoice paid or payable by Interprise America hereunder by an amount that is, on an annualized basis, greater than two percent (2%) of the aggregate charges for the Services and Elements during the period covered by the audit.
- 11.1.6 Upon (i) the discovery by BellSouth of overcharges not previously reimbursed to Interprise America or (ii) the resolution of disputed audits, BellSouth shall promptly reimburse Interprise America the amount of any overpayment times the highest interest rate (in decimal value) which may

be levied by law for commercial transactions, compounded daily for the number of days from the date of overpayment to and including the date that payment is actually made. In no event, however, shall interest be assessed on any previously assessed or accrued late payment charges.

- 11.2 Subject to reasonable security requirements, either Party may audit the books, records and other documents of the other for the purpose of evaluating usage pertaining to transport and termination of local traffic. Such audit may include examination of the flow of call detail records from the switch to the internal systems to the usage file transmitted. Where such usage data is being transmitted through CABS, the audit shall be conducted in accordance with CABS or other applicable requirements approved by the appropriate State Commission. If data is not being transferred via CABS, either Party may request an audit for such purpose once each Contract Year. Either Party may employ other persons or firms for this purpose. Any such audit shall take place no later than thirty (30) days after notice thereof to the other Party.
- 11.2.1 Either Party shall promptly correct any reported usage error that is revealed in an audit, including making payment of any underpayment after the Parties have agreed upon the accuracy of the audit results. Any Disputes concerning audit results shall be resolved pursuant to the procedures described in Section 15 of the General Terms and Conditions of this Agreement.
- 11.2.2 The Parties shall cooperate fully in any such audit, providing reasonable access to any and all appropriate employees and books, records and other documents reasonably necessary to assess the usage pertaining to transport and terminating of local traffic.

12. **Performance Measurement**

- 12.1 In providing Services and Elements, BellSouth will provide Interprise America with the quality of service BellSouth provides itself, a subsidiary, an Affiliate or any other Party. BellSouth's performance under this Agreement shall provide Interprise America with the capability to meet standards or other measurements that are at least equal to the level that BellSouth provides or is required to provide by law and its own internal procedures. BellSouth shall satisfy all service standards, measurements, and performance requirements set forth in the Agreement and the specific quality measurements that the Parties may mutually agree within forty-five (45) days of the approval of this Agreement.
- 12.2 **DELETED**
- 12.3 **Left Blank Intentionally.**

13. **Force Majeure**

13.1 Neither Party shall be liable for any delay or failure in performance of any part of this Agreement caused by a Force Majeure condition, including acts of the United States of America or any state, territory or political subdivision thereof, acts of God or a public enemy, fires, floods, freight embargoes, strikes, earthquakes, volcanic actions, wars, civil disturbances or other causes beyond the reasonable control of the Party claiming excusable delay or other failure to perform. Force Majeure shall not include acts of any Governmental Authority relating to environmental, health or safety conditions at Work Locations. If any Force Majeure condition occurs, the Party whose performance fails or is delayed because of such Force Majeure condition shall give prompt notice to the other Party, and upon cessation of such Force Majeure condition, shall give like notice and commence performance hereunder as promptly as reasonably practicable. In the event of a Force Majeure condition, both Parties agree to treat the other Party in a nondiscriminatory fashion.

13.2 Notwithstanding Section 13.1, no delay or other failure to perform shall be excused pursuant to this Section 13 by the acts or omission of a Party's subcontractors, material persons, suppliers or other third persons providing products or services to such Party unless: (i) such acts or omissions are themselves the product of a Force Majeure condition, (ii) such acts or omissions do not relate to environmental, health or safety conditions at Work Locations and, (iii) unless such delay or failure and the consequences thereof are beyond the control and without the fault or negligence of the Party claiming excusable delay or other failure to perform. Notwithstanding the foregoing, this Section 13 shall not excuse failure or delays where BellSouth is required to implement Disaster Recovery plans to avoid such failures and delays in performance.

14. **Certain Federal, State and Local Taxes**

14.1 **Definition** For purposes of this Section 14, the terms "taxes" and "fees" shall include but not be limited to federal, state or local sales, use, excise, gross receipts or other taxes or tax-like fees of whatever nature and however designated (including tariff surcharges and any fees, charges or other payments, contractual or otherwise, for the use of public streets or rights of way, whether designated as franchise fees or otherwise) imposed on, or sought to be imposed on, either of the Parties and measured by the charges or payments, for the services furnished hereunder, excluding any taxes levied on income.

14.2 **Taxes And Fees Imposed Directly On Either Seller Or Purchaser**

- 14.2.1 Taxes and fees imposed on the providing Party, which are neither permitted nor required to be passed on by the providing Party to its Customer, shall be borne and paid by the providing Party.
- 14.2.2 Taxes and fees imposed on the purchasing Party, which are not required to be collected and/or remitted by the providing Party, shall be borne and paid by the purchasing Party.
- 14.3 **Taxes and Fees Imposed on Purchaser But Collected and Remitted by Provider**
- 14.3.1 Taxes and fees imposed on the purchasing Party shall be borne by the purchasing Party, even if the obligation to collect and/or remit such taxes or fees is placed on the providing Party.
- 14.3.2 To the extent permitted by Applicable Law, any such taxes and/or fees shall be shown as separate items on applicable billing documents between the Parties. Notwithstanding the foregoing, the purchasing Party shall remain liable for any such taxes and fees regardless of whether they are actually billed by the providing Party at the time that the respective service is billed.
- 14.3.3 If the purchasing Party determines that in its opinion any such taxes or fees are not lawfully due the providing Party shall not bill such taxes or fees to the purchasing Party if the purchasing Party provides written certification, reasonably satisfactory to the providing Party, stating that it is exempt or otherwise not subject to the tax or fee, setting forth the basis therefor, and satisfying any other requirements under Applicable Law. If any authority seeks to collect any such tax or fee that the purchasing Party has determined and certified not to be lawfully due, or any such tax or fee that was not billed by the providing Party, the purchasing Party may contest the same in good faith, at its own expense. In the event that such contest must be pursued in the name of the providing Party, the providing Party shall permit the purchasing Party to pursue the contest in the name of providing Party and the providing Party shall have the opportunity to participate fully in the preparation of such contest. In any such contest, the purchasing Party shall promptly furnish the providing Party with copies of all filings in any proceeding, protest, or legal challenge, all rulings issued in connection therewith, and all correspondence between purchasing Party and the taxing authority.
- 14.3.4 In the event that all or any portion of an amount sought to be collected must be paid in order to contest the imposition of any such tax or fee, or to avoid the existence of a lien on the assets of the providing Party during the pendency or such contest, the purchasing Party shall be responsible for such payment and shall be entitled to the benefit of any refund or recovery.

- 14.3.5 If it is ultimately determined that any additional amount of such a tax or fee is due to the imposing authority, the purchasing Party shall pay such additional amount, including any interest and penalties thereon.
- 14.3.6 Notwithstanding any provision to the contrary, the purchasing Party shall protect, indemnify and hold harmless (and defend at the purchasing Party's expense) the providing Party from and against any such tax or fee, interest or penalties thereof, or other charges or payable expenses (including reasonable attorney fees) with respect thereto, which are reasonably and necessarily incurred by the providing Party in connection with any claim for or contest of any such tax or fee.
- 14.3.7 Each Party shall notify the other Party in writing of any assessment, proposed assessment or other claim for any additional amount of such a tax or fee by a taxing authority; such notice to be provided, if possible, at least ten (10) days prior to the date by which a response, protest or other appeal must be filed, but in no event later than thirty (30) days after receipt of such assessment, proposed assessment or claim.
- 14.4 **Taxes And Fees Imposed On Seller But Passed On To Purchaser**
- 14.4.1 Taxes and fees imposed on providing Party, which are permitted or required to be passed on by the providing Party to its Customer, shall be borne by the purchasing Party.
- 14.4.2 To the extent permitted by Applicable Law, any such taxes and/or fees shall be shown as separate items on applicable billing documents between the Parties. Notwithstanding the foregoing, the purchasing Party shall remain liable for any such taxes and fees regardless of whether they are actually billed by the providing Party at the time that the respective service is billed.
- 14.4.3 If the purchasing Party disagrees with the providing Party's determination as to the application or basis for any such tax or fee, the Parties shall consult with respect to the imposition and billing of such tax or fee and with respect to whether to contest the imposition of such tax or fee. Notwithstanding the foregoing, the providing Party shall retain responsibility for determining whether and to what extent any such taxes or fees are applicable. The providing Party shall further retain responsibility for determining whether and how to contest the imposition of such taxes or fees; provided, however, the Parties agree to consult in good faith as to such contest and that any such contest undertaken at the request of purchasing Party shall be at the purchasing Party's expense. In the event that such contest must be pursued in the name of the providing Party, providing Party shall permit purchasing Party to pursue the contest in the name of providing Party and the providing Party shall have the opportunity to participate fully in the preparation of such contest.

- 14.4.4 If, after consultation in accordance with the preceding Section 14.4.3, the purchasing Party does not agree with the providing Party's final determination as to the application or basis of a particular tax or fee, and if the providing Party, after receipt of a written request by the purchasing Party to contest the imposition of such tax or fee with the imposing authority, fails or refuses to pursue such contest or to allow such contest by the purchasing Party, the purchasing Party may utilize the procedures in Section 15 of the General Terms and Conditions of this Agreement. Utilization of the dispute resolution process shall not relieve the purchasing Party from liability for any tax or fee billed by the providing Party pursuant to this subsection during the pendency of such dispute resolution proceeding. In the event that the purchasing Party prevails in such dispute resolution proceeding, it shall be entitled to a refund in accordance with the final decision therein. Notwithstanding the foregoing, if at any time prior to a final decision in such dispute resolution proceeding the providing Party initiates a contest with the imposing authority with respect to any of the issues involved in such dispute resolution proceeding, the dispute resolution proceeding shall be dismissed as to such common issues and the final decision rendered in the contest with the imposing authority shall control as to such issues.
- 14.4.5 In the event that all or any portion of an amount sought to be collected must be paid in order to contest the imposition of any such tax or fee with the imposing authority, or to avoid the existence of a lien on the assets of the providing Party during the pendency of such contest, the purchasing Party shall be responsible for such payment and shall be entitled to the benefit of any refund or recovery.
- 14.4.6 If it is ultimately determined that any additional amount of such a tax or fee is due to the imposing authority, the purchasing Party shall pay such additional amount, including any interest and penalties thereon.
- 14.4.7 Notwithstanding any provision to the contrary, the purchasing Party shall protect, indemnify and hold harmless (and defend at the purchasing Party's expense) the providing Party from and against any such tax or fee, interest or penalties thereon, or other reasonable charges or payable expenses (including reasonable attorney fees) with respect thereto, which are incurred by the providing Party in connection with any claim for or contest of any such tax or fee.
- 14.4.8 Each Party shall notify the other Party in writing of any assessment, proposed assessment or other claim for any additional amount of such a tax or fee by a taxing authority, such notice to be provided, if possible, at least ten (10) days prior to the date by which a response, protest or other appeal must be filed, but in no event later than thirty (30) days after receipt of such assessment, proposed assessment or claim.

14.5 **Mutual Cooperation**

In any contest of a tax or fee by one Party, the other Party shall cooperate fully by providing records, testimony and such additional information or assistance as may reasonably be necessary to pursue the contest. Further, the other Party shall be reimbursed for any reasonable and necessary out-of-pocket copying and travel expenses incurred in assisting in such contest. Each Party agrees to indemnify and hold harmless the other Party from and against any losses, damages, claims, demands, suits, liabilities and expenses, including reasonable attorney's fees, that arise out of its failure to perform its obligations under this section.

15. **Dispute Resolution**

15.1 If any claim, controversy or dispute between the Parties, their agents, employees, officers, directors or affiliated agents ("Disputes") cannot be settled through negotiation, it shall be resolved in accordance with the rules of the CPR Institute for Dispute Resolution Rules for Non-administered Arbitration and Business Disputes. The Federal Arbitration Act, 9 U.S.C. Secs. 1-16, not state law, shall govern the arbitrability of all Disputes. Selected arbitrator(s) shall not be affiliated with either party and must possess certain legal, accounting, telecommunications or business experience relevant to the issue(s) in dispute. The arbitrator shall not have authority to award punitive damages. All arbitration awards will be final and binding and not subject to judicial review except on one or more of those grounds specified in the Federal Arbitration Act as amended. Judgment on the award rendered by the arbitrator(s) may be entered in any court having jurisdiction thereof. Each party shall bear its own costs and attorneys' fees, and shall share equally in the fees and expenses of the arbitrator. The arbitration shall occur in Atlanta, Georgia.

15.2 No Dispute, regardless of the form of action, arising out of this Agreement, may be brought by either Party more than two (2) years after the cause of action accrues.

16. **Notices**

Any notices or other communications required or permitted to be given or delivered under this Agreement shall be in hard-copy writing (unless otherwise specifically provided herein) and shall be sufficiently given if delivered personally or delivered by prepaid overnight express service to the following (unless otherwise specifically required by this Agreement to be delivered to another representative or point of contact):

If to Interprise America:

Audrey Thompson
INTERPRISE America

1999 Broadway
Room 700
Denver, CO 80202

If to BellSouth:

OLEC Account Team
3535 Colonnade Parkway
Room E4E1
Birmingham, AL 35243

General Attorney--Interconnection
Suite 4300
675 W. Peachtree St.
Atlanta, GA 30375

Either Party may unilaterally change its designated representative and/or address for the receipt of notices by giving seven (7) days prior written notice to the other Party in compliance with this Section. Any notice or other communication shall be deemed given when received.

17. **Confidentiality and Proprietary Information**

17.1 For the purposes of this Agreement, "Confidential Information" means confidential or proprietary technical or business Information given by the Discloser to the Recipient. All information which is disclosed by one Party to the other in connection with this Agreement shall automatically be deemed proprietary to the Discloser and subject to this Agreement, unless otherwise confirmed in writing by the Discloser. In addition, by way of example and not limitation, all orders for Services and Elements placed by Interprise America pursuant to this Agreement, and information that would constitute Customer Proprietary Network pursuant to the Act and the rules and regulations of the Federal Communications Commission, and Recorded Usage Data as described in Attachment 7, whether disclosed by Interprise America to BellSouth or otherwise acquired by BellSouth in the course of the performance of this Agreement, shall be deemed Confidential Information of Interprise America for all purposes under this Agreement.

17.2 For a period of five (5) years from the receipt of Confidential Information from the Discloser, except as otherwise specified in this Agreement, the Recipient agrees (a) to use it only for the purpose of performing under this Agreement, (b) to hold it in confidence and disclose it to no one other than its employees having a need to know for the purpose of performing under this Agreement, and (c) to safeguard it from unauthorized use or disclosure with at least the same degree of care with which the Recipient safeguards its own Confidential Information. If the Recipient wishes to

disclose the Discloser's Confidential Information to a third party agent or consultant, the agent or consultant must have executed a written agreement of non-disclosure and non-use comparable in scope to the terms of this Section.

- 17.3 The Recipient may make copies of Confidential Information only as reasonably necessary to perform its obligations under this Agreement. All such copies shall bear the same copyright and proprietary rights notices as are contained on the original.
- 17.4 The Recipient agrees to return all Confidential Information in tangible form received from the Discloser, including any copies made by the Recipient, within thirty (30) days after a written request is delivered to the Recipient, or to destroy all such Confidential Information, except for Confidential Information that the Recipient reasonably requires to perform its obligations under this Agreement. If either Party loses or makes an unauthorized disclosure of the other Party's Confidential Information, it shall notify such other Party immediately and use reasonable efforts to retrieve the lost or wrongfully disclosed information.
- 17.5 The Recipient shall have no obligation to safeguard Confidential Information: (a) which was in the possession of the Recipient free of restriction prior to its receipt from the Discloser; (b) after it becomes publicly known or available through no breach of this Agreement by the Recipient; (c) after it is rightfully acquired by the Recipient free of restrictions on its disclosure; or (d) after it is independently developed by personnel of the Recipient to whom the Discloser's Confidential Information had not been previously disclosed. In addition, either Party shall have the right to disclose Confidential Information to any mediator, arbitrator, state or federal regulatory body, the Department of Justice or any court in the conduct of any mediation, arbitration or approval of this Agreement or in any proceedings concerning the provision of interLATA services by BellSouth that are or may be required by the Act. Additionally, the Recipient may disclose Confidential Information if so required by law, a court, or governmental agency, so long as the Discloser has been notified of the requirement promptly after the Recipient becomes aware of the requirement. In all cases, the Recipient must undertake all lawful measures to avoid disclosing such information until Discloser has had reasonable time to seek and comply with a protective order that covers the Confidential Information to be disclosed.
- 17.6 Each Party's obligations to safeguard Confidential Information disclosed prior to expiration or termination of this Agreement shall survive such expiration or termination.
- 17.7 Except as otherwise expressly provided elsewhere in this Agreement, no license is hereby granted under any patent, trademark or copyright, nor is

any such license implied solely by virtue of the disclosure of any Confidential Information.

- 17.8 Each Party agrees that the Discloser would be irreparably injured by a breach of this Agreement by the Recipient or its representatives and that the Discloser shall be entitled to seek equitable relief, including injunctive relief and specific performance, in the event of any breach of the provisions of this Agreement. Such remedies shall not be deemed to be the exclusive remedies for a breach of this Agreement, but shall be in addition to all other remedies available at law or in equity.

18. **Branding**

The Parties agree that the services offered by Interprise America that incorporate Services and Elements made available to Interprise America pursuant to this Agreement shall be branded as Interprise America services. BellSouth shall not be required to brand directory assistance for Interprise America unless BellSouth chooses to brand its directory assistance for its customers. Interprise America shall provide the exclusive interface to Interprise America Customers, except as Interprise America shall otherwise specify. In those instances where Interprise America requires BellSouth personnel or systems to interface with Interprise America Customers, such personnel shall identify themselves as representing Interprise America, and shall not identify themselves as representing BellSouth. Except for material provided by Interprise America, all forms, business cards or other business materials furnished by BellSouth to Interprise America Customers shall be subject to Interprise America's prior review and approval. In no event shall BellSouth, acting on behalf of Interprise America pursuant to this Agreement, provide information to Interprise America local service Customers about BellSouth products or services. BellSouth agrees to provide in sufficient time for Interprise America to review and provide comments, the methods and procedures, training and approaches, to be used by BellSouth to assure that BellSouth meets Interprise America's branding requirement. For installation and repair services, Interprise America agrees to provide BellSouth with branded material at no charge for use by BellSouth ("Leave Behind Material"). Interprise America will reimburse BellSouth for the reasonable and demonstrable costs BellSouth would otherwise incur as a result of the use of the generic leave behind material. BellSouth will notify Interprise America of material supply exhaust in sufficient time that material will always be available. BellSouth will not be liable for any error, mistake or omission, other than intentional acts or omissions or gross negligence, resulting from the requirements to distribute Interprise America's Leave Behind Material.

19. **Directory Listings Requirements**

- 19.1 BellSouth shall make available to Interprise America, for Interprise America customers, non-discriminatory access to its telephone number and address directory listings ("Directory Listings"), under the below terms and conditions. In no event shall Interprise America customers receive Directory Listings that are at less favorable rates, terms or conditions than the rates, terms or conditions that BellSouth provides its customers.
- 19.1.1 **DELETED**
- 19.1.2 **DELETED**
- 19.1.3 Subject to execution of an Agreement between Interprise America and BellSouth's affiliate, BellSouth Advertising & Publishing Corporation ("BAPCO") substantially in the form set forth in Attachment 13: (1) listings shall be included in the appropriate White Pages or local alphabetical directories (including Foreign Language directories as appropriate), via the BellSouth ordering process, (basic listing shall be at no charge to Interprise America or Interprise America's customers); (2) Interprise America's business customers' listings shall also be included in the appropriate Yellow Pages or local classified directories, via the BellSouth ordering process, at no charge to Interprise America or Interprise America's customers; (3) copies of such directories shall be delivered by BAPCO to Interprise America's customers; (4) Interprise America will sell enhanced White Pages Listings to Interprise America customers and BellSouth shall provide the enhanced White Listings; and (5) Yellow Pages Advertising will be sold and billed to Interprise America customers.
- 19.1.4 BAPCO will provide Interprise America the necessary publishing information to process Interprise America's customers directory listings requests including, but not limited to:
1. Classified Heading Information
 2. Telephone Directory Coverage Areas by NPA/NXX
 3. Publishing Schedules
 4. Processes for Obtaining Foreign Directories
 5. Information about Listing Interprise America's Customer Services, including telephone numbers, in the Customer Call Guide Pages.
- 19.2 BellSouth will provide Interprise America the proper format for submitting customer listings as outlined in the OLEC Handbook. BellSouth and BAPCO will accord Interprise America's directory listing information the same level of confidentiality that BellSouth and BAPCO accord BellSouth's and BAPCO'S own directory listing information, and BellSouth shall limit access to Interprise America's Customer proprietary,

confidential directory information to those BellSouth or BAPCO employees who are involved in the preparation of listings.

- 19.3 BellSouth will include Interprise America customer listings in BellSouth's directory assistance databases and BellSouth will not charge Interprise America to maintain the Directory Assistance database. The Parties agree to cooperate with each other in formulating appropriate procedures regarding lead time, timeliness, format, and content of listing information.

20. **Subscriber List Information/Local Number Portability**

- 20.1 BellSouth shall refer any requests from third parties for Interprise America's Customer List Information to Interprise America.

- 20.2 Local Number Portability shall be provided as set forth in Attachment 8.

21.A **Insurance Requirements**

Both parties agree that they, at their own cost and expense, shall maintain throughout the term of this Agreement, all insurance required by law, and may at their own cost and expense purchase insurance or self-insure their employer, public, professional and legal liabilities. No limit of liability on any policy, no program or self-insurance, nor any failure to maintain adequate insurance coverage shall limit the direct or indirect liability of either party.

21.B **Costs**

Except as otherwise specified in this Agreement, the Act, or any Commission order, each Party shall be responsible for all costs and expenses that it incurs to comply with its obligations under this Agreement.

21.B.1 **DELETED**

21.C **Pre-Ordering Information**

- 21.C.1 BellSouth shall provide Interprise America with access on a real-time basis via electronic interfaces to all services and features technically available from each switch, by switch CLLI and access to street address detail for the provisioning of a service request. This information is currently contained in BellSouth's Regional Street Address Guide ("RSAG") and Products and Services Inventory Management (P/SIMS).

- 21.C.2 If Interprise America dials in, Interprise America will obtain from BellSouth a security card featuring a unique password identification which will be changed periodically by BellSouth. A nonrecurring charge of One Hundred (\$100.00) Dollars will be applied to each security card provided,

including duplicates furnished to additional users or furnished as a replacement of lost or stolen cards.

- 21.C.3 Interprise America acknowledges that (i) this information is provided for the limited purposes of facilitating the establishment of new customer accounts and identifying services and features available in specific BellSouth central offices. Interprise America agrees that it will not sell or otherwise transfer such information to any third party for any purpose whatsoever without the prior written consent of BellSouth; (ii) BellSouth does not warrant that services provided under this Section will be uninterrupted or error free. In the event of interruptions, delays, errors or other failure of the services, BellSouth's obligation shall be limited to using reasonable efforts under the circumstances to restore the services. BellSouth shall have no obligation to retrieve or reconstruct any transmitted messages or transmission data which may be lost or damaged. Interprise America is responsible for providing back-up for data deemed by BellSouth to be necessary to its operations; (iii) the services provided under this Section are provided "As Is." BellSouth makes no warranty, express or implied, with respect to the services, including but not limited to any warranty of merchantability or fitness for a particular purpose, which warranties are hereby expressly disclaimed.

21.D **Disaster Recovery**

BellSouth and Interprise America agree to jointly develop and implement a detailed service restoration plan and disaster recovery plan to be in effect by December 31, 1997. A joint task team will commence development within 30 days of the execution of this Agreement for implementation throughout 1997 reaching full deployment by December 31, 1997.

Such plans shall incorporate BellSouth Emergency Contingency Plans for Residence and Business Repair Centers. The Plans shall conform to the FCC Restoration Guidelines, to the National Security Emergency Preparedness ("NSEP") procedures and adhere to the guidelines developed by the Telecommunications Service Priority ("TSP") System office within the National Communications System ("NCS") Agency.

In developing the plans, the team will address the following Interprise America proposed terms: (i) provision for immediate notification to Interprise America via the Electronic Interface, to be established pursuant to Section 3 of Attachment 6 of the Agreement, of the existence, location and source of any emergency network outage affecting Interprise America Customers; (ii) establishment of a single point of contact responsible for initiating and coordinating the restoration of all Local Services and Network Elements or Combinations; (iii) establishment of procedures to provide Interprise America with real-time access to information relating to the status of restoration efforts and problem resolution during the

restoration process; (iv) provision of an inventory and description of mobile restoration equipment by locations; (v) establishment of methods and procedures for the dispatch of mobile equipment to the restoration site; (vi) establishment of methods and procedures for re-provisioning all Services and Elements, after initial restoration; (vii) provision for equal priority, as between Interprise America Customers and BellSouth Customers, for restoration efforts, consistent with FCC Service Restoration guidelines, including, but not limited to, deployment of repair personnel and access to spare parts and components; and (viii) establishment of a mutually agreeable process for escalation of maintenance problems, including a complete, up-to-date list of responsible contacts, available twenty-four (24) hours per day, seven (7) days per week.

Such plans shall be modified and updated as necessary. For purposes of this Section, an emergency network outage is defined as 5,000 or more blocked call attempts in a ten (10) minute period in a single exchange.

In the event the Parties are unable to reach an agreement on either plan, the matter shall be resolved pursuant to the procedures set forth in Section 15 of the General Terms and Conditions of this Agreement.

21. DELETED

22. Miscellaneous

22.1 Delegation or Assignment

BellSouth may not assign any of its rights or delegate any of its obligations under this Agreement without the prior written consent of Interprise America which will not be unreasonably withheld. Notwithstanding the foregoing, BellSouth may assign its rights and benefits and delegate its duties and obligations under this Agreement without the consent of Interprise America to a 100 percent owned Affiliate company of BellSouth if such Affiliate provides wireline communications, provided that the performance of any such assignee is guaranteed by the assignor. Any prohibited assignment or delegations shall be null and void.

22.2 Subcontracting

If any Party's obligation under this Agreement is performed by a subcontractor or Affiliate, the Party subcontracting the obligation nevertheless shall remain fully responsible for the performance of this Agreement in accordance with its terms, and shall be solely responsible for payments due its subcontractors or Affiliate. In entering into any contract, subcontract or other agreement for the performance of any obligation under this Agreement, the Party shall not enter into any

agreement that it would not enter into if the supplier was performing services directly for said Party.

22.3 Nonexclusive Remedies

Except as otherwise expressly provided in this Agreement, each of the remedies provided under this Agreement is cumulative and is in addition to any remedies that may be available at law or in equity.

22.4 No Third-Party Beneficiaries

Except as may be specifically set forth in this Agreement, this Agreement does not provide and shall not be construed to provide third parties with any remedy, claim, liability, reimbursement, cause of action, or other privilege.

22.5 Referenced Documents

Whenever any provision of this Agreement refers to a technical reference, technical publication, BellSouth Practice, any publication of telecommunications industry administrative or technical standards, or any other document specifically incorporated into this Agreement, it will be deemed to be a reference to the most recent version or edition (including any amendments, supplements, addenda, or successors) of such document that is in effect, and will include the most recent version or edition (including any amendments, supplements, addenda, or successors) of each document incorporated by reference in such a technical reference, technical publication, BellSouth Practice, or publication of industry standards (unless Interprise America elects otherwise). Should there be an inconsistency between or among publications or standards, the Parties shall mutually agree upon which requirement shall apply.

22.6 Applicable Law

The validity of this Agreement, the construction and enforcement of its terms, and the interpretation of the rights and duties of the Parties shall be governed by the laws of the State of Georgia other than as to conflicts of laws, except insofar as federal law may control any aspect of this Agreement, in which case federal law shall govern such aspect. The Parties submit to personal jurisdiction in Atlanta, Georgia.

22.7 Publicity and Advertising

Neither Party shall publish or use any advertising, sales promotions or other publicity materials that use the other Party's logo, trademarks or service marks without the prior written approval of the other Party.

22.8 Amendments or Waivers

Except as otherwise provided in this Agreement, no amendment or waiver of any provision of this Agreement, and no consent to any default under this Agreement, shall be effective unless the same is in writing and signed by an officer of the Party against whom such amendment, waiver or consent is claimed. In addition, no course of dealing or failure of a Party strictly to enforce any term, right or condition of this Agreement shall be construed as a waiver of such term, right or condition.

22.9 Severability

If any term, condition or provision of this Agreement is held to be invalid or unenforceable for any reason, such invalidity or unenforceability shall not invalidate the entire Agreement, unless such construction would be unreasonable. The Agreement shall be construed as if it did not contain the invalid or unenforceable provision or provisions, and the rights and obligations of each Party shall be construed and enforced accordingly; provided, however, that in the event such invalid or unenforceable provision or provisions are essential elements of this Agreement and substantially impair the rights or obligations of either Party, the Parties shall promptly negotiate a replacement provision or provisions.

22.10 Entire Agreement

This Agreement, which shall include the Attachments, Appendices and other documents referenced herein, constitutes the entire Agreement between the Parties concerning the subject matter hereof and supersedes any prior agreements, representations, statements, negotiations, understandings, proposals or undertakings, oral or written, with respect to the subject matter expressly set forth herein.

22.11 Survival of Obligations

Any liabilities or obligations of a Party for acts or omissions prior to the cancellation or termination of this Agreement, any obligation of a Party under the provisions regarding indemnification, Confidential Information, limitations on liability, and any other provisions of this Agreement which, by their terms, are contemplated to survive (or to be performed after) termination of this Agreement, shall survive cancellation or termination thereof.

22.12 Executed in Counterparts

This Agreement may be executed in any number of counterparts, each of which shall be deemed an original; but such counterparts shall together constitute one and the same instrument.

22.13 **Headings of No Force or Effect**

The headings of Articles and Sections of this Agreement are for convenience of reference only, and shall in no way define, modify or restrict the meaning or interpretation of the terms or provisions of this Agreement.

Part I: Local Services Resale

23. Telecommunications Services Provided for Resale

23.1 At the request of Interprise America, and pursuant to the requirements of the Act, BellSouth will make available to Interprise America for resale (see Section 24.3 of Part 1) any Telecommunications Service that BellSouth currently provides, or may offer hereafter. BellSouth shall also provide Support Functions and Service Functions, as set forth in Sections 27 and 28 of this Part. The Telecommunications Services, Service Functions and Support Functions provided by BellSouth to Interprise America pursuant to this Agreement are collectively referred to as "Local Service."

23.2 This Part describes several services which BellSouth shall make available to Interprise America for resale pursuant to this Agreement. This list of services is neither all inclusive nor exclusive. All Telecommunications Services of BellSouth which are to be offered for resale pursuant to the Act are subject to the terms herein, even though they are not specifically enumerated or described.

23.2.1 **Features and Functions Subject to Resale**

BellSouth agrees to make available for resale all features and functions available in connection with Telecommunications Services, including but not limited to the following:

- Dial tone and ring
- Capability for either dial pulse or touch tone recognition
- Capability to complete calls to any location
- Same extended local calling area
- 1+ IntraLATA toll calling
- PIC 1+ service
- CIC dialing (10 XXXX)
- Same access to vertical features and functions
- Call detail recording capability required for end user billing
- Flat and Measured Service
- International Calling
- 911, 500, 700, 800, 888, 900, 976 dialing
- Ringling
- Repeat dial capability
- Multi-line hunting
- PBX trunks and DID service

23.3 BellSouth will provide Interprise America with at least the capability to provide a Interprise America Customer the same experience as BellSouth provides its own Customers with respect to all Local Services. The

capability provided to Interprise America by BellSouth shall be in accordance with standards or other measurements that are at least equal to the level that BellSouth provides itself, any affiliate, other local service providers, its end users or is required to provide by law and its own internal procedures.

24. **General Terms and Conditions for Resale**

24.1 **Primary Local Exchange Carrier Selection**

BellSouth shall apply the principles set forth in Section 64.1100 of the Federal Communications Commission Rules, 47 C.F.R. §64.1100, to the process for end-user selection of a primary local exchange carrier. BellSouth shall not require a disconnect order from the Customer, another carrier, or another entity, in order to process an Interprise America order for Local Service for a Customer.

24.2 **Pricing**

The prices charged to Interprise America for Local Service are set forth in Part IV of this Agreement.

24.3 **Restrictions on Resale**

With the exception of short-term promotions, defined as those promotions that are offered for a ninety (90) day period or less and which are not offered on a consecutive basis, BellSouth shall offer for resale at wholesale prices all telecommunications services that BellSouth provides at retail to non-telecommunications carriers. Short-term promotions shall be available for resale at the retail rate. Long-term promotions, defined as those offered from more than ninety (90) days, will be available at the tariffed rate less the wholesale discount. The Telecommunications Services available for resale at the wholesale discount include grandfathered or obsolete services, 911 and E911, Lifeline, when available, Link-up, and contract service arrangements subject to the following:

- (i) LifeLine, when available, and Link-up services shall be available for resale by Interprise America only to those customers who are eligible to purchase such service directly from BellSouth. Link-up shall be discounted by at least the percentage currently being used by BellSouth. In addition, Interprise America is responsible for applying to NECA to receive compensating funds as BellSouth currently does.
- (ii) All grandfathered services are available for resale by Interprise America to only those customers currently eligible to receive them including those BellSouth customers who

change from BellSouth to an alternative local exchange carrier ("ALEC"); and

- (iii) E911/911 services shall be available for resale by Interprise America.

Reasonable and non-discriminatory use and user restrictions contained in BellSouth's tariffs may be applicable to the resale of BellSouth's telecommunications services, only to the extent BellSouth meets its burden of proving to the Commission that any such restriction is reasonable and non-discriminatory.

24.3.1 **Dialing Parity**

- 24.3.1.1 BellSouth agrees that Interprise America Customers will experience the same dialing parity as BellSouth's Customers, such that, for all call types: (i) a Interprise America Customer is not required to dial any greater number of digits than a BellSouth Customer; (ii) the post-dial delay (time elapsed between the last digit dialed and the first network response), call completion rate and transmission quality experienced by a Interprise America Customer is at least equal in quality to that experienced by a BellSouth Customer; and (iii) the Interprise America Customer may retain its local telephone number.

24.3.2 **Changes in Retail Service**

- 24.3.2.1 BellSouth agrees to notify Interprise America electronically of any changes in the terms and conditions under which it offers Telecommunications Services to subscribers who are nontelecommunications carriers, including, but not limited to, the introduction or discontinuance of any features, functions, services or promotions, at least 45 days prior to the effective date of any such change or concurrent with BellSouth's internal notification process for such change, whichever is earlier. Interprise America recognizes that certain revisions may occur between the time BellSouth notifies Interprise America of a change pursuant to this Section and BellSouth's tariff filing of such change. BellSouth shall notify Interprise America of such revisions consistent with BellSouth's internal notification process but Interprise America accepts the consequences of such mid-stream changes as an uncertainty of doing business and, therefore, will not hold BellSouth responsible for any resulting inconvenience or cost incurred by Interprise America unless caused by the intentional misconduct of BellSouth for the purposes of this Section. The notification given pursuant to this Section will not be used by either party to market its offering of such changed services externally in advance of BellSouth filing of any such changes.

- 24.3.2.2 BellSouth agrees to notify Interprise America electronically of proposed price changes at least 30 days prior to the effective date of any such price change.
- 24.3.2.3 BellSouth agrees to notify Interprise America of any operational changes within at least six (6) months before such changes are proposed to become effective and within twelve months for any technological changes. If such operational or technological changes occur within the six or twelve month notification period, BellSouth will notify Interprise America of the changes concurrent with BellSouth's internal notification process for such changes.

25. **Requirements for Specific Services**

25.1 **CENTREX Requirements**

At Interprise America's option, Interprise America may purchase CENTREX services. Where Interprise America purchases such CENTREX services, Interprise America may purchase the entire set of features, any single feature, or any combination of features which BellSouth has the capability to provide. BellSouth will provide Interprise America with the same service levels and features of CENTREX service provided by BellSouth to its end users. Requests by Interprise America for CENTREX service levels and features that are different from what BellSouth provides to its end users will be handled under the Bona Fide Request Process. The CENTREX service provided for resale will meet the following requirements:

- 25.1.1 All features and functions of CENTREX service, whether offered under tariff or otherwise, shall be available to Interprise America for resale, without any geographic or Customer class restrictions.
- 25.1.2 BellSouth's CENTREX service may be used by Interprise America to provide Local Service to Interprise America's end users
- 25.1.3 BellSouth shall provide to Interprise America a list which describes all CENTREX features and functions offered by BellSouth within ten (10) days of the Effective Date of this Agreement, and shall provide updates to said list as required by Section 24.3.2 of Part 1.
- 25.1.4 **DELETED**
- 25.1.5 Interprise America may aggregate the CENTREX local exchange and IntraLATA traffic usage of Interprise America Customers to qualify for volume discounts on the basis of such aggregated usage.
- 25.1.6 Interprise America may aggregate multiple Interprise America Customers on dedicated access facilities. Interprise America may require that

BellSouth suppress the need for Interprise America Customers to dial "9" when placing calls outside the CENTREX system. When dedicated facilities are utilized, BellSouth will provide, upon Interprise America's request, station ID or ANI, as well as FGD trunking.

- 25.1.7 Interprise America may use remote call forwarding in conjunction with CENTREX service to provide service to Interprise America Local Service Customers residing outside of the geographic territory in which BellSouth provides local exchange service. In cases where existing BellSouth Customers choose Interprise America for their local service provider, and where Interprise America serves these Customers via CENTREX, in order that such Customers may keep the same phone number, BellSouth shall either move Customer's line and phone number to a CENTREX system, or use remote call forwarding to route Customer's old phone number to new CENTREX phone number. Not all features and functions will be compatible when remote call forwarding is utilized. In such cases, Interprise America customers shall have the same functionality as BellSouth customers under the same circumstances.
- 25.1.8 **DELETED**
- 25.1.9 BellSouth shall make available to Interprise America for resale, at no additional charge, intercom calling among all Interprise America Customers who utilize resold CENTREX service where the Interprise America Customers' numbers all reside in the same central office switch.
- 25.1.10 Interprise America may utilize BellSouth's Automatic Route Selection (ARS) service features to provision and route calls from various end users to various Interexchange Carriers (IXC) Networks.

25.2 **CLASS and Custom Features Requirements**

Interprise America may purchase the entire set of CLASS and Custom features and functions, or a subset of any one or any combination of such features, on a Customer-specific basis, without restriction on the minimum or maximum number of lines or features that may be purchased for any one level of service. BellSouth shall provide to Interprise America a list of all such CLASS and Custom features and functions within ten (10) days of the Effective Date of this Agreement. BellSouth shall provide notice of new CLASS features and functions pursuant to Section 24.3.2 of Part 1.

25.3 **Voluntary Federal and State Customer Financial Assistance Programs**

Local Services provided to low-income subscribers, pursuant to requirements established by the appropriate state regulatory body, include programs such as Voluntary Federal Customer Financial Assistance Program and Link-Up America ("Voluntary Federal Customer Financial

Assistance Programs"). When a BellSouth Customer eligible for the Voluntary Federal Customer Financial Assistance Program or other similar state programs chooses to obtain Local Service from Interprise America, BellSouth shall forward available information regarding such Customer's eligibility to participate in such programs to Interprise America, in accordance with procedures to be mutually established by the Parties and applicable state and federal law.

25.4 **E911/911 Services**

BellSouth shall provide access to E911/911 in the same manner that it is provided to BellSouth Customers. BellSouth will enable Interprise America Customers to have E911/911 call routing to the appropriate Public Safety Answering Point (PSAP). BellSouth shall provide and validate Interprise America Customer information to the PSAP. BellSouth shall use its service order process to update and maintain, on the same schedule that it uses for its end users, the Interprise America Customer service information in the Automatic Location Identification/Database Management System ("ALI/DMS") used to support E911/911 services.

25.4.1 **DELETED**

25.4.2 **Telephone Relay Service**

Where BellSouth provides to speech and hearing-impaired callers a service that enables callers to type a message into a telephone set equipped with a keypad and message screen and to have a live operator read the message to a recipient and to type message recipient's response to the speech or hearing-impaired caller ("Telephone Relay Service"), BellSouth shall make such service available to Interprise America at no additional charge, for use by Interprise America Customers who are speech or hearing-impaired. If BellSouth maintains a record of Customers who qualify under any applicable law for Telephone Relay Service, BellSouth shall make such data available to Interprise America as it pertains to Interprise America Customers.

25.5 **Contract Service Arrangements ("CSA's")**

25.5.1 CSAs shall be available for resale at the contract rate with no discount applied if the underlying service is not contained in BellSouth's tariff. However, if the underlying services are contained in BellSouth's tariff, Interprise America may purchase those services only at the wholesale discounts off the tariffed price.

25.5.2 If Interprise America identifies a specific CSA, BellSouth shall provide Interprise America a copy within ten (10) business days of Interprise America's request.

25.6 **DELETED**

25.7 **DELETED**

25.8 **DELETED**

25.9 **DELETED**

25.10 **Nonrecurring Services**

25.10.1 BellSouth shall offer for resale all non-recurring services.

25.11 **Inside Wire Maintenance Service**

25.11.1 BellSouth shall provide Inside Wire Maintenance Service at rates, terms and conditions as mutually agreed to by the parties.

25.12 **Pay Phone Service**

BellSouth shall offer for resale, at a minimum, the following pay phone services: Coin Line (currently sold as SmartLinesm), COCOT Line Coin (currently sold as Independent Payphone Provider (IPP) Line), and COCOT Line Coinless (currently sold as IPP Line Coinless). To the extent BellSouth demonstrates that it does not provide the payphone features and functionality requested by Interprise America to BellSouth Customers, Interprise America may request that BellSouth provide such functionality pursuant to the Bona Fide Request Process identified in Section 1.1 of the General Terms and Conditions of this Agreement.

- Billed Number Screening
- Originating line screening
- Ability to "freeze" PIC selection
- One bill per line
- Point of demarcation at the Network Interface location
- Detailed billing showing all 1+ traffic on paper, diskette or electronic format
- Wire Maintenance option
- Touchtone service
- Option for listed or non-listed numbers
- Access to 911 service
- One directory per line
- Access to ANI Information
- Line and/or station monitoring and diagnostic routines

25.12.1 In addition, BellSouth shall offer for resale, at a minimum, the following features with its resold Coin Line service:

- Access to all CO intelligence required to perform answer detection, coin collection, coin return, and disconnect.
- Answer Detection
- Option to block all 1+ calls to international destinations

IntraLATA Call Timing

Option of one way or two way service on line

Coin Refund and Repair Referral Service

Ability to block any 1+ service that cannot be rated by the coin circuits

Interprise America rate tables for local and intraLATA service

Option of Flat Rate Service or Measured Service or both

Protect against clip on fraud

Protect against blue box fraud

- 25.12.2 BellSouth shall offer for resale, at a minimum, the following features with its COCOT Line Coin and COCOT Line Coinless services:

Ability to keep existing serving telephone numbers if cutover to

Interprise America Resale Line

Option of One Way or Two Way service on the line

Option of Flat Rate Service or Measured Service or both

- 25.12.3 BellSouth shall offer for resale, at a minimum, the following feature with its COCOT Line Coin service:

Blocking for 1+ international, 10XXXX1+ international, 101XXXX1+ international, 1+900, N11, 976

Option to block all 1-700 and 1-500 calls

Line side supervision option

- 25.12.4 BellSouth shall offer for resale, at a minimum, the following features with its COCOT Line Coinless service:

Blocking for 1+ international, 10XXXX1+ international, 101XXXX1+ international, 1+900, N11, 976, 7 or 10 digit local, 1+DDD

- 25.12.5 BellSouth shall offer for resale, at a minimum, the following features with its SemiPublic Coin service:

Ability to keep existing serving telephone numbers if cutover to

Interprise America

Touchtone Service

Option for listed, nonlisted, or non published numbers

Provision 911 service

Access to ANI information

Access to all CO intelligence required to perform answer supervision, coin collect, coin return and disconnect

Far end disconnect recognition

Call timing

PIC protection for all 1+local, interLATA, and intraLATA traffic

Same call restrictions as available on BellSouth phones for interLATA, international, intraLATA, and local calling

One bill per line

Detailed billing showing all 1+ traffic in paper or electronic format

Option to have enclosure installed with set
 One directory per line installed
 Install the station to at least BellSouth standards
 Ability to block any 1+ service that cannot be rated by the coin circuits
 Interprise America to be the PIC for local and intraLATA calls
 Option to block all 1+ international calls
 Option of one way or two way service
 Wire Maintenance option
 Interprise America rate tables for local and intraLATA service
 Option to have BellSouth techs collect, count, and deposit vault contents on behalf of Interprise America
 Monitor vault contents for slugs and spurious non-US currency or theft and notify Interprise America of discrepancies
 Station or enclosure equipment should only bear the name/brand designated by Interprise America on the order form
 Protect against clip on fraud
 Protect against red box fraud
 Protect against blue box fraud
 Provide option for use of "bright" station technology including debit cards
 Provide revenue, maintenance, collection reports as specified by Interprise America on order form on a periodic basis in paper or electronic format

25.12.6 BellSouth shall provide the following features for Coin Line, SemiPublic Coin, COCOT Line Coin, and COCOT Line Coinless services:

Blocking of inbound international calls
 Point of demarcation at the set location
 Special screen codes unique to Interprise America and/or its Customers
 Single Point of Contact for bills and orders dedicated to Public
 Service outage transfers to Interprise America help center
 Access to Interprise America Directory Assistance
 Access to Interprise America's Network Access Interrupt
 Use Interprise America branded invoice
 Provide all information requested to ensure Interprise America can bill for access line
 Provide all information requested to ensure Interprise America can bill for usage on the line
 All calls originating from stations serviced by these lines should be routed to Interprise America lines, except where designated

25.13 **Voice Mail Service**

25.13.1 Where available to BellSouth's end users, BellSouth shall provide the following feature capabilities to allow for voice mail services:

Station Message Desk Interface - Enhanced ("SMDI-E")
 Station Message Desk Interface ("SMDI")
 Message Waiting Indicator ("MWI") stutter dialtone and message
 waiting light feature capabilities
 Call Forward on Busy/Don't Answer ("CF-B/DA")
 Call Forward on Busy ("CF/B")
 Call Forward Don't Answer ("CF/DA")

- 25.13.2 BellSouth's retail voice mail service shall be available for resale at rate terms and conditions as mutually agreed to by the parties.
- 25.14 **Hospitality Service**
- 25.14.1 BellSouth shall provide all blocking, screening, and all other applicable functions available for hospitality lines.
- 25.15 **Blocking Service**
- 25.15.1 BellSouth shall provide blocking of 700, 900, 976 and any new services of this type individually or in any combination upon request, including bill to third party and collect calls. Blocking shall be provided on a line, trunk or individual service basis at parity with what BellSouth provides its end users.
26. **DELETED**
- 26.1 **DELETED**
- 26.1.1 **DELETED**
- 26.1.2 **DELETED**
- 26.1.3 **DELETED**
- 26.1.4 **DELETED**
27. **Support Functions**
- 27.1 Routing to Directory Assistance, Operator and Repair Services
- 27.1.1.1 **DELETED**
- 27.1.1.2 **DELETED**
- 27.1.1.3 **DELETED**
- 27.1.2 **DELETED**

27.1.3 DELETED

27.1.4 BellSouth, no later than fifteen (15) days after the Effective Date of this Agreement, shall provide to Interprise America, the emergency public agency (e.g., police, fire, ambulance) telephone numbers linked to each NPA-NXX. Such data will be compiled as an electronic flat file in a mutually agreed format and transmitted via either diskette or Network Data Mover. BellSouth will transmit to Interprise America, in a timely manner, all changes, alterations, modifications and updates to such data base via the same method as the initial transfer.

27.2 Operator Services - Interim Measures

27.2.1 Where BellSouth is the provider of Directory Assistance service, BellSouth agrees to provide Interprise America Customers with the same Directory Assistance available to BellSouth Customers. If requested by Interprise America, BellSouth will provide Interprise America Directory Assistance Service under the Interprise America brand.

27.2.1.1 Interprise America recognizes that BellSouth's providing to Interprise America Directory Assistance Service under Interprise America's brand may require additional costs to be incurred by BellSouth. BellSouth will charge Interprise America for such branded Directory Assistance capability under the wholesale rate plus the reasonable and demonstrable costs necessary to implement Interprise America's branding request.

27.2.2 Additionally, BellSouth warrants that such service will provide the following minimum capabilities to Interprise America's Customers:

- (1) Two Customer listings and/or addresses per Interprise America Customer call.
- (2) Name and address to Interprise America Customers upon request, except for unlisted numbers, in the same states where such information is provided to BellSouth Customers.
- (3) Upon request, call completion to the requested number for local and intraLATA toll calls, where this service is available.
- (4) Populate the listing database in the same manner and in the same time frame as if the Customer was a BellSouth Customer.
- (5) Any information provided by a Directory Assistance Automatic Response Unit (ARU) will be repeated the same number of times for Interprise America Customers as for BellSouth's Customers.

- (6) Service levels will comply with applicable state regulatory requirements for:
 - a) number of rings to answer
 - b) average work time
 - c) disaster recovery options.
- (7) Intercept service for Customers moving service will include:
 - a) referral to new number, either 7 or 10 digits
 - b) repeat of the new number twice on the referral announcement
 - c) repeat of the new recording twice.

27.2.3 BellSouth shall provide Operator Services to Interprise America's Customers at the same level of service available to BellSouth end users.

27.2.4 **DELETED**

27.2.5 BellSouth agrees to provide Interprise America Customers the same Operator Services available to BellSouth Customers, branded as required by Section 19.

27.2.6 Additionally, BellSouth warrants that such service will provide the following minimum capabilities to Interprise America Customers:

- (1) Instant credit on calls, as provided to BellSouth Customers.
- (2) Routing of calls to Interprise America when requested via existing Operator Transfer Service (OTS).
- (3) Busy Line Verification/Emergency Line Interrupt (BLV/ELI) services.
- (4) Emergency call handling.
- (5) Notification of the length of call.
- (6) Caller assistance for the disabled in the same manner as provided to BellSouth Customers.
- (7) Handling of collect calls: person to person and/or station to station.

27.3 **Busy Line Verification and Emergency Line Interrupt**

Where BellSouth does not route Operator Services traffic to Interprise America's platform, BellSouth shall perform Busy Line Verification and Emergency Line Interrupt for Interprise America on resold BellSouth lines. Where BellSouth routes Operator Services traffic to Interprise America's platform, BellSouth shall provide BLV/ELI services when requested by Interprise America Operators. Interprise America and BellSouth shall work together to ensure that sufficient facilities exist to support increased BLV/ELI volume due to Interprise America's presence as a Local Service provider. Specifically, BellSouth will engineer its BLV/ELI facilities to accommodate the anticipated volume of BLV/ELI requests during the Busy Hour. Interprise America may, from time to time, provide its anticipated volume of BLV/ELI requests to BellSouth for planning purposes. In those instances when the BLV/ELI facilities/systems cannot satisfy forecasted volumes, BellSouth shall promptly inform Interprise America, and the Parties shall work together to resolve capacity problems expeditiously.

27.4 Access to the Line Information Database

BellSouth shall use its service order process to update and maintain, on the same schedule that it uses for its end users, the Interprise America Customer service information in the Line Information Database ("LIDB").

27.5 Telephone Line Number Calling Cards

Effective as of the date of an end-user's subscription to Interprise America Service, BellSouth will terminate its existing telephone line number - based calling cards and remove any BellSouth-assigned Telephone Line Calling Card Number (including area code) ("TLN") from the LIDB. Interprise America may issue a new telephone calling card to such Customer, utilizing the same TLN and enter such TLN in LIDB for calling card validation purposes via the service order process.

28. Service Functions

28.1 Electronic Interface

BellSouth shall provide real time electronic interfaces ("EI") for transferring and receiving Service Orders and Provisioning data and materials (e.g., access to Street Address Guide ("SAG") and Telephone Number Assignment database). These interfaces shall be administered through a gateway that will serve as a point of contact for the transmission of such data from Interprise America to BellSouth, and from BellSouth to Interprise America. The requirements and implementation of such a data transfer system shall be negotiated in good faith by the Parties as specified below and in Attachment 15 of this Agreement. Interprise America and BellSouth agree to use best efforts to provide the Electronic

Communications gateway described above as soon as practicable, but in no event later than the dates specified in Attachment 15. In addition, (i) BellSouth agrees to use its best efforts to carry out its responsibilities, and (ii) Interprise America agrees to use its best efforts to carry out its responsibilities. Interprise America and BellSouth have agreed on interim solutions described below and in Attachment 15 to address the Pre-ordering, Ordering and Provisioning interfaces. BellSouth warrants that such interim solutions shall provide Interprise America Customers with the same level of service available to BellSouth Customers.

28.2 Pre-Ordering

28.2.1.1 **DELETED**

28.2.1.2 **DELETED**

28.2.1.3 BellSouth will supply Interprise America with Interval Guide Job Aids to be used to determine service installation dates. BellSouth will implement an electronic interface to its Due Date Support Application (DSAP).

28.2.1.4 BellSouth will reserve up to 100 telephone numbers per NPA-NXX at Interprise America's request, for Interprise America's sole use. BellSouth will provide additional numbers at Interprise America's request in order that Interprise America have sufficient numbers available to meet expected needs. The telephone number reservations made in this manner are valid for Interprise America's assignment for ninety (90) days from the reservation date. BellSouth will make the telephone number reservations available to Interprise America via diskette. BellSouth agrees to implement an electronic interface to improve this process.

28.2.1.5 BellSouth Local Carrier Service Center ("LCSC") will assign vanity numbers and blocks of numbers for use with complex services including, but not limited to, DID and Hunting arrangements, as requested by Interprise America, and documented in Work Center Interface agreements.

28.2.1.6 BellSouth will migrate all Pre-ordering functionality to the "Pre-Ordering" Electronic Communications Gateway. This migration effort shall be accomplished as described by BellSouth in its "Phase II interactive solution" report to the Georgia Public Service Commission of July 21, 1996, and any subsequent ordered or agreed to modifications.

Ordering

28.2.1.7 BellSouth agrees to develop, and Interprise America agrees to cooperate in the development of, a mutually acceptable Electronic Data Interchange (EDI) for ordering Local Services. The ordering process and related

transactions, (i.e., order, confirmation, firm order commitments, supplements and completions) shall be via the EDI interface.

28.2.1.8 BellSouth agrees to implement the EDI interface to support processes for Local Services for residence POTS and features, business POTS and features and PBX trunks with Direct Inward Dialing. The Parties will agree on a time frame to implement ordering for all Local Services via EDI interface.

28.2.1.9 **DELETED**

28.3 **Work Order Processes**

28.3.1 BellSouth shall ensure that all work order processes used to provision Local Service to Interprise America for resale meet the service parity requirements set forth in this part.

28.3.2 Prior to Interprise America sending BellSouth the first Service Order, BellSouth and Interprise America shall develop mutually agreed-upon escalation and expedite procedures to be employed at any point in the Service Ordering, Provisioning, Maintenance, Billing and Customer Usage Data transfer processes to facilitate rapid and timely resolution of disputes. These procedures will be maintained in the Work Center Interface Agreements.

28.4 **Point of Contact for the Interprise America Customer**

28.4.1 Except as otherwise provided in this Agreement, Interprise America shall be the single and sole point of contact for all Interprise America Customers.

28.4.2 **DELETED**

28.4.3 BellSouth representatives who receive inquiries regarding Interprise America services shall refer such inquiries to Interprise America at a telephone number provided by Interprise America. BellSouth representatives shall interact with Interprise America customers in an efficient and courteous manner. BellSouth representatives shall be expressly prohibited from engaging in any marketing practices in connection with misdirected calls.

28.5 **Single Point of Contact**

28.5.1 Each Party shall provide the other Party with a single point of contact ("SPOC") for all inquiries regarding the implementation of this Part. Each Party shall accept all inquiries from the other Party and provide timely responses.

28.5.2 BellSouth Contact numbers will be kept current in the Work Center Interface Agreements.

28.6 **Service Order**

To facilitate the ordering of new service for resale or changes to such service to a Interprise America Customer ("Service Order"), BellSouth shall provide Interprise America's representative with real time access (as described in Section 28.1 of this Part 1) to BellSouth Customer information to enable the Interprise America representative to perform the following tasks:

28.6.1 Obtain Customer profile information via telephone. Methods and procedures for this interim interface will be defined in a Work Center Interface Agreement.

28.6.2 Obtain information on all Telecommunication Services that are available for resale, including new services via an electronic file with feature and service information in each BellSouth switch.

FOC Receipt time

28.6.3 BellSouth will provide Interprise America with interactive direct order entry. Until this capability is available, BellSouth agrees to establish the Local Carrier Service Center ("LCSC") as the SPOC for order entry. Orders will be received at the "LCSC" via the EDI interface. BellSouth agrees to enter the Service Order promptly on receipt and provide Firm Order Confirmation ("FOC") within 24 hours of receipt of a correct Local Service Request.

28.6.4 BellSouth will provide Interprise America with on line access to telephone number reservations. Until on line access is available via electronic interface, and Section 28.1.1 of this Part I, BellSouth agrees to provide Interprise America with a ready supply of telephone numbers. The process for telephone number reservations is described in Section 28.2.1.4 of this Agreement.

28.6.5 BellSouth will provide Interprise America with the capability to establish directory listings via the Service Order Process.

28.6.6 BellSouth will provide Interprise America with the appropriate information and training materials (job aids) to assist Interprise America work centers to determine whether a service call will be required on a service installation. These job aids are to be the same information available to BellSouth employees.

28.6.7 BellSouth will provide Interprise America on line ability to schedule and dispatch. Until on line access is available, and subject to Section 28.1.1

of this Part I, BellSouth agrees to provide Interprise America with interval guides for BellSouth services. Said intervals will provide Interprise America the capability of providing the same level of service to a Interprise America customer that BellSouth provides its own end users, any affiliate customers, or any other local carrier's customers.

28.6.8 BellSouth will provide Interprise America with the ability to order local service, local intraLATA toll service, and designate the end users' choice of primary intraLATA and interLATA Interexchange Carriers on a single unified order.

28.6.9 BellSouth will suspend, terminate or restore service to a Interprise America Customer at Interprise America's request.

28.7 **Provisioning**

28.7.1 **DELETED**

28.7.1.1 **DELETED**

28.7.1.2 **DELETED**

28.7.1.3 **DELETED**

28.7.1.4 **DELETED**

28.7.1.5 **DELETED**

28.7.2 BellSouth shall provide Interprise America with service status notices, within mutually agreed-upon intervals. Such status notices shall include the following:

28.7.2.1 Firm order confirmation, including service availability date and information regarding the need for a service dispatch for installation.

28.7.3 BellSouth will provide Interprise America with on-line notice of service installation. Until this capability is available, and subject to Section 28.1.1 of this Part I, BellSouth will provide Interprise America with completion information on a daily basis for all types of Service Orders. BellSouth will utilize the EDI interface to transmit that data to Interprise America. If an installation requires deviation from the Service Order in any manner, or if a Interprise America Customer requests a service change at the time of installation, BellSouth will call Interprise America in advance of performing the installation for authorization. BellSouth will provide to Interprise America at that time an estimate of additional labor hours and/or materials required for that installation. After installation is completed, BellSouth will inform Interprise America of actual labor hours and/or materials used within one (1) business day.

- 28.7.4 BellSouth will provide Interprise America with on-line information exchange for Service Order rejections, Service Order errors, installation jeopardies and missed appointments by no later than March 31, 1997, until this capability is available, and subject to Section 28.1.1 of this Part I, BellSouth agrees to:
- 28.7.4.1 Use its best efforts to notify Interprise America via telephone of any Service Order rejections or errors within one hour of receipt;
- 28.7.4.2 Confirm such telephone notices in writing via facsimile at the end of each business day; and
- 28.7.4.3 BellSouth shall notify Interprise America via telephone in a timely manner if an installation or service appointment is in jeopardy of being missed.
- 28.7.4.4 The notification process will be described further in the Work Center Interface Agreement between Interprise America and BellSouth.
- 28.7.5 **DELETED**
- 28.7.6 BellSouth will provide Interprise America with on-line information on charges associated with necessary construction. Until this capability is available, BellSouth agrees that BellSouth's LCSC will promptly notify Interprise America of any charges associated with necessary construction.
- 28.7.7 BellSouth will provide Interprise America with on-line access to status information on Service Orders. Until this capability is available, and subject to Section 28.1.1 of this Part I, BellSouth agrees to provide status at the following critical intervals: acknowledgment, firm order confirmation and completion on Service Orders. In addition, BellSouth Local Carrier Service Center will provide Interprise America with status, via telephone, upon request.
- 28.7.8 BellSouth will perform all pre-service testing on resold Local Services.
- 28.7.9 Where BellSouth provides installation and the Interprise America Customer requests a service change at the time of installation, BellSouth shall immediately notify Interprise America at the telephone number on the Service Order of that request. The BellSouth technician should notify Interprise America in the presence of the Interprise America Customer so that Interprise America can negotiate authorization to install the requested services directly with that Customer and the technician, and revise appropriate ordering documents as necessary.
- 28.7.10 **DELETED**
- 28.7.10.1 BellSouth shall provide Interprise America with the capability to have Interprise America's Customer orders input to and accepted by

BellSouth's Service Order Systems outside of normal business hours, twenty-four (24) hours a day, seven (7) days a week, the same as BellSouth's Customer orders received outside of normal business orders are input and accepted.

- 28.7.10.2 Such ordering and provisioning capability shall be provided via an electronic interface, except for scheduled electronic interface downtime. Downtime shall not be scheduled during normal business hours and shall occur during times where systems experience minimum usage.
- 28.7.10.3 Until the Electronic Interface is available, BellSouth shall provide Local Carrier Service Center ("LCSC") order entry capability to Interprise America to meet the requirements set forth in Section 28.7.10.1 above.
- 28.7.11 BellSouth shall provide training for all BellSouth employees who may communicate with Interprise America Customers, during the provisioning process. Such training shall conform to Section 19 of the General Terms and Conditions of this Agreement.
- 28.7.12 BellSouth will provide Interprise America with the capability to provide Interprise America Customers the same ordering, provisioning intervals, and level of service experiences as BellSouth provides to its own Customers, in accordance with standards or other measurements that are at least equal to the level that BellSouth provides or is required to provide by law and its own internal procedures.
- 28.7.13 BellSouth will maintain and staff an account team to support Interprise America's inquiries concerning the ordering of local complex service and designed business services for local services resale. This team will provide information regarding all services, features and functions available, know the forms and additional information required beyond the standard local service request, assist Interprise America in preparation of such orders, and provide coordination within BellSouth to ensure compliance with the provisions of this Agreement.
- 28.7.14 BellSouth will provide Interprise America with the information Interprise America will need to certify Customers as exempt from charges, or eligible for reduced charges associated with the provisioning of new services, including but not limited to handicapped individuals, and certain governmental bodies and public institutions. BellSouth, when notified that an order for new service is exempt in some fashion, will not bill Interprise America.
- 28.7.15 BellSouth will provide the same intercept treatment and transfer of service announcements to Interprise America's Customers as BellSouth provides to its own end users without any branding.

- 28.7.16 BellSouth will provide Interprise America with appropriate notification of all area transfers with line level detail 120 days before service transfer, and will also notify Interprise America within 120 days before such change of any LATA boundary changes, or within the time frame required by an approving regulatory body, if any.
- 28.7.17 BellSouth agrees to develop with Interprise America's cooperation, mutually acceptable interface agreements between work centers regarding the exchange of information and process expectations.
- 28.7.18 BellSouth will suspend Interprise America local Customers' service upon Interprise America's request via the receipt of a Local Service Request. The service will remain suspended until such time as Interprise America submits a Local Service Request requesting BellSouth to reactivate.
- 28.7.19 BellSouth will provide Interprise America's end users the same call blocking options available to BellSouth's own end users.
- 28.7.20 BellSouth will work cooperatively with Interprise America in practices and procedures regarding Law Enforcement and service annoyance call handling. To the extent that circuit-specific engineering is required for resold services, BellSouth will provide the same level of engineering support as BellSouth provides for its comparable retail services.
- 28.7.21 BellSouth will provide information about the certification process for the provisioning of LifeLine, Link-up and other similar services.
- 28.7.22 BellSouth will provide a daily electronic listing of Interprise America Customers who change their local carrier. The process is described as OUTPLOC (See reference in Local Account Maintenance Requirements of Attachment 7.)

28.8 **Maintenance**

Maintenance shall be provided in accordance with the requirements and standards set forth in Attachment 5. Maintenance will be provided by BellSouth in accordance with the service parity requirements set forth in this Part.

28.9 **Provision of Customer Usage Data**

BellSouth shall provide the Customer Usage Data recorded by the BellSouth. Such data shall include complete Interprise America Customer usage data for Local Service, including both local and intraLATA toll service (e.g., call detail for all services, including flat-rated and usage-sensitive features), in accordance with the terms and conditions set forth in Attachment 7.

28.10 Service/Operation Readiness Testing

- 28.10.1 In addition to testing described elsewhere in this Section, BellSouth shall test the systems used to perform the following functions in a mutually agreed upon time frame prior to commencement of BellSouth's provision of Local Service, in order to establish system readiness capabilities:
- 28.10.1.1 All interfaces between Interprise America and BellSouth work centers for Service Order, Provisioning;
 - 28.10.1.2 Maintenance, Billing and Customer Usage Data;
 - 28.10.1.3 The process for BellSouth to provide Customer profiles;
 - 28.10.1.4 The installation scheduling process;
 - 28.10.1.5 **DELETED**
 - 28.10.1.6 Telephone number assignment;
 - 28.10.1.7 Procedures for communications and coordination between Interprise America SPOC and BellSouth SPOC;
 - 28.10.1.8 Procedures for transmission of Customer Usage Data; and
 - 28.10.1.9 Procedures for transmitting bills to Interprise America for Local Service; and the process for wholesale billing for local service.
- 28.10.2 The functionalities identified above shall be tested by BellSouth in order to determine whether BellSouth performance meets the applicable service parity requirements, quality measures and other performance standards set forth in this Agreement. BellSouth shall make available sufficient technical staff to perform such testing. BellSouth technical staff shall be available to meet with Interprise America as necessary to facilitate testing. BellSouth and Interprise America shall mutually agree on the schedule for such testing.
- 28.10.3 At Interprise America's reasonable request, BellSouth shall provide Interprise America with service readiness test results of the testing performed pursuant to the terms of this Part.
- 28.10.4 During the term of this Agreement, BellSouth shall participate in cooperative testing requested by Interprise America whenever both companies agree it is necessary to ensure service performance, reliability and customer serviceability.
- 28.11 Billing For Local Service**

- 28.11.1 BellSouth shall bill Interprise America for Local Service provided by BellSouth to Interprise America pursuant to the terms of this Part, and in accordance with the terms and conditions for Connectivity Billing and Recording in Attachment 6.
- 28.11.2 BellSouth shall recognize Interprise America as the Customer of record for all Local Service and will send all notices, bills and other pertinent information directly to Interprise America unless Interprise America specifically requests otherwise.

PART II: UNBUNDLED NETWORK ELEMENTS

29. **Introduction**

This Part II sets forth the unbundled Network Elements that BellSouth agrees to offer to Interprise America in accordance with its obligations under Section 251(c)(3) of the Act. The specific terms and conditions that apply to the unbundled Network Elements and the requirements for each Network Element are described below and in the Network Elements Service Description, Attachment 2. The price for each Network Element is set forth in Part IV of this Agreement. BellSouth shall offer Network Elements to Interprise America as of the Effective Date of this Agreement.

30. **Unbundled Network Elements**

30.1 BellSouth shall offer Network Elements to Interprise America on an unbundled basis on rates, terms and conditions that are just, reasonable and non-discriminatory in accordance with the terms and conditions of this Agreement.

30.2 BellSouth will permit Interprise America to interconnect Interprise America's facilities or facilities provided by Interprise America or by third parties with each of BellSouth's unbundled Network Elements at any point designated by Interprise America that is technically feasible.

30.3 BellSouth will deliver to Interprise America's Served Premises any interface that is technically feasible. Interprise America, at its option, may designate other interfaces through the Bona Fide Request process delineated in Attachment 14.

30.4 Interprise America may use one or more Network Elements to provide any feature, function or service option that such Network Element is capable of providing or any feature, function or service option that is described in the technical references identified herein.

30.5 BellSouth shall offer each Network Element individually in order to permit Interprise America to provide Telecommunications Services to its Customers subject to the provisions of Section 1A of the General Terms and Conditions of this Agreement.

30.6 For each Network Element, BellSouth shall provide a demarcation point (e.g., an interconnection point at a Digital Signal Cross Connect or Light Guide Cross Connect panel or a Main Distribution Frame) and, if necessary, access to such demarcation point, which Interprise America agrees is suitable. However, where BellSouth provides contiguous Network Elements to Interprise America, BellSouth may provide the existing interconnections and no demarcation point shall exist between such contiguous Network Elements.

30.7 DELETED

30.8 DELETED

30.9 Attachment 2 of this Agreement describes the Network Elements that Interprise America and BellSouth have identified as of the Effective Date of this Agreement. Interprise America and BellSouth agree that the Network Elements identified in Attachment 2 are not exclusive. Either Party may identify additional or revised Network Elements as necessary to improve services to Customers, to improve network or service efficiencies or to accommodate changing technologies, Customer demand, or regulatory requirements. Upon BellSouth's identification of a new or revised Network Element, BellSouth shall notify Interprise America as soon as practicable on a nondiscriminatory basis of the existence, the technical characteristics and availability of a new or revised Network Element.

Interprise America shall make its request for a new or revised Network Element pursuant to the Bona Fide Request Process identified in Section 1.1 of the General Terms and Conditions of this Agreement. Additionally, if BellSouth provides any Network Element that is not identified in this Agreement, to itself, to its own Customers, to a BellSouth affiliate or to any other entity, BellSouth will provide the same Network Element to Interprise America on rates, terms and conditions no less favorable to Interprise America than those provided to itself or to any other party. Additional descriptions and requirements for each Network Element are set forth in Attachment 2.

30.9.1 DELETED

30.9.2 DELETED

30.9.3 DELETED

30.9.4 DELETED

30.9.5 DELETED

30.9.6 DELETED

30.9.7 DELETED

30.9.8 DELETED

30.9.9 DELETED

30.9.10 DELETED

30.9.11 DELETED

30.10 Standards for Network Elements

- 30.10.1 BellSouth shall comply with the requirements set forth in the technical references, as well as any performance or other requirements identified in this Agreement, to the extent that they are consistent with the greater of BellSouth's actual performance or applicable industry standards. If another Bell Communications Research, Inc. ("Bellcore"), or industry standard (e.g., American National Standards Institute ("ANSI")) technical reference or a more recent version of such reference sets forth a different requirement, Interprise America may request, where technically feasible, that a different standard apply by making a request for such change pursuant to the Bona Fide Request Process identified in Section 1.1 of the General Terms and Conditions of this Agreement.
- 30.10.2 If one or more of the requirements set forth in this Agreement are in conflict, the parties shall mutually agree on which requirement shall apply. If the parties cannot reach agreement, the procedures set forth in Section 15 of the General Terms and Conditions of this Agreement shall apply.
- 30.10.3 Each Network Element provided by BellSouth to Interprise America shall be at least equal in the quality of design, performance, features, functions and other characteristics, including but not limited to levels and types of redundant equipment and facilities for power, diversity and security, that BellSouth provides in the BellSouth network to itself, BellSouth's own Customers, to a BellSouth affiliate or to any other entity for the same Network Element.
- 30.10.3.1 **DELETED**
- 30.10.3.2 BellSouth agrees to work cooperatively with Interprise America to provide Network Elements that will meet Interprise America's needs in providing services to its Customers.
- 30.10.4 Unless otherwise designated by Interprise America, each Network Element and the interconnections between Network Elements provided by BellSouth to Interprise America shall be made available to Interprise America on a priority basis that is equal to or better than the priorities that BellSouth provides to itself, BellSouth's own Customers, to a BellSouth affiliate or to any other entity for the same Network Element.

PART III: ANCILLARY FUNCTIONS

31. **Introduction**

This Part and Attachment 3 set forth the Ancillary Functions and requirements for each Ancillary Function that BellSouth agrees to offer to Interprise America so that Interprise America may provide Telecommunication Services to its Customers.

32. **BellSouth Provision of Ancillary Functions**

Part IV of this Agreement sets forth the prices for such Ancillary Functions. BellSouth will offer Ancillary Functions to Interprise America on rates, terms and conditions that are just, reasonable, and non-discriminatory and in accordance with the terms and conditions of this Agreement.

32.1 The Ancillary Functions that Interprise America has identified as of the Effective Date of this Agreement are Collocation, Rights Of Way (ROW), Conduits and Pole Attachments. Interprise America and BellSouth agree that the Ancillary Functions identified in this Part III are not exclusive. Either Party may identify additional or revised Ancillary Functions as necessary to improve services to Customers, to improve network or service efficiencies or to accommodate changing technologies, Customer demand, or regulatory requirements. Upon BellSouth's identification of a new or revised Ancillary Function, BellSouth shall notify Interprise America as soon as practicable on a nondiscriminatory basis of the existence, the technical characteristics and availability of a new or revised Ancillary Function.

Interprise America shall make its request for a new or revised Ancillary Function pursuant to the Bona Fide Request Process identified in Section 1.1 of the General Terms and Conditions of this Agreement.

32.2 If BellSouth provides any Ancillary Function to itself, to its own Customers, to a BellSouth affiliate or to any other entity, BellSouth will provide the same Ancillary Function to Interprise America at rates, terms and conditions no less favorable to Interprise America than those provided by BellSouth to itself or to any other Party. The Ancillary Functions and requirements for each Ancillary Function are set forth in Attachment 3.

33. **Standards for Ancillary Functions**

33.1 Each Ancillary Function shall meet or exceed the requirements set forth in the technical references, as well as the performance and other requirements, identified in this Agreement. If another Bell Communications Research, Inc. ("Bellcore"), or industry standard (e.g., American National Standards Institute ("ANSI")) technical reference sets forth a different requirement, Interprise America may elect, where

technically feasible, which standard shall apply by making a request for such change pursuant to the Bona Fide Request Process identified in Section 1.1 of the General Terms and Conditions of this Agreement.

33.2 Except as otherwise expressly agreed to herein, each Ancillary Function provided by BellSouth to Interprise America herein shall be at least equal in the quality of design, performance, features, functions and other characteristics, including, but not limited to levels and types of redundant equipment and facilities for diversity and security, that BellSouth provides in BellSouth network to itself, its own Customers, its affiliates or any other entity. This Section is not intended to limit BellSouth's ability during this Agreement to offer to Interprise America nor Interprise America's ability to accept Ancillary Functions with varying degrees of features, functionalities and characteristics.

33.3 **DELETED**

33.3.1 BellSouth agrees to work cooperatively with Interprise America to provide Ancillary Functions that will meet Interprise America's needs in providing services to its Customers.

33.4 Ancillary Functions provided by BellSouth to Interprise America shall be allocated to Interprise America on a basis that is at least equal to that which BellSouth provides to itself, its Customers, its affiliates or any other entity.

PART IV: PRICING

34. **General Principles**

All services currently provided hereunder (including resold Local Services, Network Elements, Combinations and Ancillary Functions) and all new and additional services to be provided hereunder shall be priced in accordance with all applicable provisions of the Act and the rules and orders of the Federal Communications Commission and Kentucky Public Service Commission.

35. **Local Service Resale**

The rates that Interprise America shall pay to BellSouth for resold Local Services shall be BellSouth's Retail Rates less the applicable discount. The following discount will apply to all Telecommunications Services available for resale in Kentucky.

Residential Service	16.79%
Business Service:	15.54%

36. **Unbundled Network Elements**

The prices that Interprise America shall pay to BellSouth for Unbundled Network Elements are set forth in Table 1.

37. **Compensation For Call and Transport Termination**

The prices that Interprise America shall pay to BellSouth are set forth in Table 1.

38. **Ancillary Functions**

38.1 Collocation - The prices that Interprise America shall pay to BellSouth are set forth in Table 2.

38.2 Rights-of-Way - The prices that Interprise America shall pay to BellSouth are set forth in Table 3.

38.3 Poles, Ducts and Conduits - The prices that Interprise America shall pay to BellSouth are set forth in Table 4.

39. **Local Number Portability**

The prices for interim number portability are set forth in Table 5.

40. **Recorded Usage Data**

The prices for recorded usage data are set forth in Table 6.

41. **Electronic Interfaces**

All costs incurred by BellSouth to implement operational interfaces shall be recovered from the ALECs on a fairly apportioned basis. If there is disagreement between the Parties regarding cost recovery issues, an affected party may petition the Kentucky Public Service Commission to initiate a separate hearing to address the matter.

42. **True-up**

Except for the prices for resold Local Services, the interim prices referenced above shall be subject to true-up on a prospective basis as determined by the Commission.

TABLE 1

UNBUNDLED NETWORK ELEMENTS

Network Interface Device, Per Month	\$1.80
Unbundled Loops	
2 Wire Analog VG Loop, per month	
Standard - with NID	\$20.00
Standard - without NID	\$18.20
Nonrecurring, with or without NID - First	\$86.08
Nonrecurring, with or without NID - Add'l	\$58.57
2 Wire Analog VG Loop, per month	
Customized - with NID	\$23.35
Customized - without NID	\$21.41
Nonrecurring, with or without NID - First	\$236.75
Nonrecurring, with or without NID - Add'l	\$177.10
4 Wire Analog VG Loop, per month	
Standard - with NID	\$28.28
Standard - without NID	\$26.38
Nonrecurring, with or without NID - First	\$457.14
Nonrecurring, with or without NID - Add'l	\$348.83
2 Wire ISDN Digital Grade Loop, per month	
Standard - with NID	\$31.99
Standard - without NID	\$29.65
Nonrecurring, with or without NID - First	\$541.28
Nonrecurring, with or without NID - Add'l	\$431.61
2 Wire ADSL Loop, per month	
Standard - with NID	\$11.89
Standard - without NID	\$10.63
Nonrecurring, with or without NID - First	\$713.50
Nonrecurring, with or without NID - Add'l	\$609.44
2 Wire HDSL Loop, per month	
Standard - with NID	\$8.51
Standard - without NID	\$7.40
Nonrecurring, with or without NID - First	\$713.50
Nonrecurring, with or without NID - Add'l	\$609.44
4 Wire HDSL Loop, per month	
Standard - with NID	\$10.39
Standard - without NID	\$9.70
Nonrecurring, with or without NID - First	\$748.93
Nonrecurring, with or without NID - Add'l	\$646.17
4 Wire DS1 Digital Grade Loop, per month	
Nonrecurring - First	\$67.96
Nonrecurring - Additional	\$849.80
Nonrecurring - Additional	\$523.27
Loop Channelization System - For Unbundled Loops	
Unbundled Loop System (DS1 to VG) per system, per month	\$429.33
Nonrecurring - First	\$664.06
Nonrecurring - Additional	\$166.55
Central Office Interface Per Circuit, per month	\$1.26
Nonrecurring - First	\$46.68
Nonrecurring - Additional	\$46.38

Local Switching, Per Month	
2 wire analog	\$2.61
Nonrecurring, Residence - First	\$37.78
Nonrecurring, Residence - Additional	\$37.78
Nonrecurring, Business, First	\$37.55
Nonrecurring, Business - Additional	\$37.55
Nonrecurring, PBX, First	\$36.47
Nonrecurring, PBX - Additional	\$36.47
4 wire Analog (Coin)	\$3.04
Nonrecurring - First	\$40.71
Nonrecurring - Additional	\$40.71
4 wire ISDN DS1	\$275.48
Nonrecurring - First	\$181.27
Nonrecurring - Additional	\$116.42
2 wire ISDN Digital	\$12.33
Nonrecurring - First	\$90.48
Nonrecurring - Additional	\$84.53
Nonrecurring - User Profile per B Channel	\$5.61
2 wire Analog Hunting - per line	\$.29
Nonrecurring	\$2.14
Local Switching, per Minute Of Use	
End Office Switching	\$.002562
Tandem Switching	\$.001096
Local Switching Features, functions, capabilities	No additional charge
Common Transport	
Common Transport, per mile, per MOU	\$.0000049
Common Transport - Facility Termination, per MOU	\$.000426
Dedicated Transport	
DS1, per mile, per month	\$.45
DS1, Facility Termination, per month	\$55.05
Nonrecurring - First	\$298.18
Nonrecurring - Additional	\$231.23
Exchange Access Interoffice Channel	
0 - 8 miles, fixed per month	\$16.14
per mile, per month	\$.0301
9 -25 miles, fixed, per month	\$17.18
per mile, per month	\$.0726
Over 25 miles, fixed, per month	\$18.41
per mile, per month	\$.0831
Nonrecurring - First	\$181.93
Nonrecurring - Additional	\$75.56
Operator Systems	
Operator Call Processing Access Service	
Operator Provided, per minute	
Using BST LIDB	\$1.6016
Using Foreign LIDB	\$1.6249
Fully Automated, per attempt	
Using BST LIDB	\$.0856
Using Foreign LIDB	\$.1071

Operator Systems, continued	
Inward Operator Services Access Service	
Verification, per call	\$1.00
Emergency Interrupt, per call	\$1.111
Directory Assistance	
Directory Assistance Access Service Calls	
Per call	\$.3136
Recording cost per announcement	\$1,664.89
Loading cost per audio unit	\$244.04
Directory Assistance Database Service	
Use Fee, per DADS customer's EU request/Listing	\$.0193
Monthly recurring	\$120.76
Direct Access to Directory Assistance Service (DADAS)	
Database service charge, per month	\$7,235.01
Database Query Charge, per query	\$.0052
Nonrecurring - DADAS service establishment	\$1,186.94
DACC Access Service	
Per Call Attempt	\$.058
Number Service Intercept Access Service	
Per Intercept Query	\$.0086
Per Intercept Query Update	\$.0055
Directory Transport	
Switched Common Transport per DA Service Call	\$.000175
Switched Common Transport per DA service call mile	\$.000004
Access Tandem Switched per DA service call	\$.000783
Switched Local Channel - DS1 level, per month	\$36.32
Nonrecurring - First	\$637.46
Nonrecurring - Additional	\$546.94
Switched Dedicated Transport - DS1 level, per mile, per month	\$.45
Facilities Termination, per month	\$55.05
Nonrecurring - First	\$298.18
Nonrecurring - Additional	\$231.18
Nonrecurring installation per trunk or signaling connection - First	\$501.98
Nonrecurring installation per trunk or signaling connection - Additional	\$13.32
CCS7 Signaling Transport Services	
Signaling connection Link, per month	\$16.31
Nonrecurring	\$354.95
Signaling Termination (Port), per month	\$174.08
Signaling Usage surrogate, per 56 Kbps facility, per month	\$329.98
Signaling Usage, per call setup message	\$.000037893
Signaling Usage, per TCAP message	\$.000102042

800 Access Ten Digit Screening Service	
800/POTS Number Delivery, per query	\$.0010
800/POTS number delivery with optional complex features, per query	\$.0011
800/800 number delivery, per query	\$.0010
800/800 number delivery with optional complex features, per query	\$.0011
Nonrecurring	
Per 800 number reserved - First	\$10.05
Per 800 number reserved - Additional	\$1.19
Per 800 number established with 800 number delivery - First	\$30.59
Per 800 number established with 800 number delivery - Additional	\$3.22
Per 800 number established with POTS number delivery - First	\$30.59
Per 800 number established per POTS number delivery - Additional	\$3.22
Customized area of service per 800 number - First	\$6.97
Customized area of service per 800 number - Additional	\$3.49
Multiple InterLATA Carrier routing per Carrier/800 number - First	\$8.16
Multiple InterLATA Carrier routing per Carrier/800 number - Additional	\$4.67
Change Charge per request - First	\$11.24
Change Charge per request - Additional	\$1.19
Call handling and Destination Features per 800 Number	\$6.97
Line Information Database Access Service	
Common Transport, per query	\$.00006
Validation, per query	\$.00938
Nonrecurring - Establishment or change	\$107.60
Call Transport and Termination (1)	
End Office switching, per MOU	\$.002562
Tandem Switching, per MOU	\$.001096
Common Transport, facility termination per MOU	\$.0000049
Common Transport, per mile per MOU	\$.000426
Intermediary Tandem, per MOU	\$.001096
Selective Routing (Interim price)	
Nonrecurring	\$10.00
Operational Support System	
OSS Electronic Interface, per order	\$10.89
(1) The Parties agree to bill a mutually agreed upon composite interconnection rate of \$0.002 until January 1, 1998, unless otherwise agreed to by the Parties. This interim composite rate shall not be subject to true-up.	

TABLE 2

PHYSICAL COLLOCATION

Application per arrangement, per location - nonrecurring	\$9,926.72
Space Preparation Fee - Nonrecurring	ICB
Space Construction Fee	
Nonrecurring per 100 square feet	\$9,985.50
Nonrecurring per each additional 50 square feet	\$1,092.21
Cable Installation - Per entrance cable	\$2,237.08
Floor Space Zone A, per square foot, per month	\$5.00
Floor Space Zone B, per square foot, per month	\$5.00
Power Per AMP, per month	\$7.68
Cable Support Structure, per entrance cable	\$24.23
POT Bay (Optional Point of Termination Bay)	
Per 2 wire cross-connect, per month	\$.06
Per 4 wire cross-connect, per month	\$.15
Per DS1 cross-connect, per month	\$.58
Per DS3 cross-connect, per month	\$4.51
Cross Connects	
2 wire analog, per month	\$.31
Nonrecurring - First	\$54.21
Nonrecurring - Additional	\$51.07
4 wire analog, per month	\$.62
Nonrecurring - first	\$54.23
Nonrecurring - Additional	\$50.96
DS1, per month	\$1.92
Nonrecurring - first	\$99.23
Nonrecurring - Additional	\$69.15
DS3, per month	\$39.94
Nonrecurring - First	\$97.48
Nonrecurring - Additional	\$66.90
Security Escort	
Basic - 1 st half hour	\$56.09
Overtime - 1 st half hour	\$67.75
Premium - 1 st half hour	\$79.41
Basic - additional	\$31.99
Overtime - additional	\$39.00
Premium - Additional	\$46.01

VIRTUAL COLLOCATION**(All prices are interim at this time)**

Rates tariffed by BellSouth in its FCC Tariff No. 1, Section 20.

TABLE 3**RIGHTS OF WAY**

BellSouth shall provide access to rights-of-way at rates that are consistent with 47 U.S.C. Section 224(d). Interprise America may file a complaint with the appropriate authority if it believes the rates provided by BellSouth are not consistent with 47 U.S.C. Section 224(d).

DARK FIBER

Temporary rates for dark fiber are as follows:

Per each fiber strand, per month, per route mile or fraction thereof	\$241.00
NRC, per each four-fiber dry fiber arrangement	
First	\$1,808.19
Additional	\$922.95

TABLE 4**POLE ATTACHMENTS, CONDUIT AND DUCT OCCUPANCY**

BellSouth shall provide access to poles, conduits and ducts at rates that are consistent with 47 U.S.C. Section 224(d). Interprise America may file a complaint with the appropriate regulatory authority if it believes the rates provided by BellSouth are not consistent with 47 U.S.C. Section 224(d). The following rates will apply at this time:

Access to poles	\$4.20 per year
Access to conduits	\$0.56 per foot
Work performed by BST employees	Loaded labor rate as developed in accordance with FCC Accounting Rules for work performed by BST

TABLE 5

INTERIM NUMBER PORTABILITY

BellSouth and Interprise America will each bear their own costs of providing remote call forwarding as an interim number portability option.

For LERG reassignment, route index-portability hub, and directory number-route index, the parties agree to continue to work toward interim rates that shall be subject to true-up according to permanent rates that the Kentucky Public Service Commission will establish in upcoming cost proceedings.

TABLE 6**RECORDED USAGE DATA**

OSS OLEC Daily Usage File	
Recording per message	\$.0008611
Message distribution, per message	\$.0032357
Message distribution, per magnetic tape provisioned	\$55.68
Data Transmission (CONNECT:DIRECT) per message	\$.0000365

43. Execution of the Interconnection Agreement by either Party does not confirm or infer that the executing Party agrees with any decision(s) issued pursuant to the Telecommunications Act of 1996 and the consequences of those decisions on specific language in this Agreement. Neither Party waives its rights to appeal or otherwise challenge any such decision(s) and each Party reserves all of its rights to pursue any and all legal and/or equitable remedies, including appeals of any such decision(s). If such appeals or challenges result in changes in the decision(s), the Parties agree that appropriate modifications to this Agreement will be made promptly to make its terms consistent with those changed decision(s).

IN WITNESS WHEREOF, the Parties have executed this Agreement through their authorized representatives.

U S WEST Interprise America, Inc.
d/b/a INTERPRISE America

BELLSOUTH
TELECOMMUNICATIONS, INC.

By: _____
Vice President/General Manager

By: _____
Jerry D. Hendrix
Director
Interconnection Services/
Pricing

Date

Date

DUPLICATE ORIGINAL

Attachment 1

Intentionally Left blank

TABLE OF CONTENTS

1. INTRODUCTION..... 2

2. LOOP COMBINATION..... 2

3. INTEGRATED DIGITAL LOOP CARRIERS 5

4. LOOP DISTRIBUTION..... 5

5. LOOP CONCENTRATOR/MULTIPLEXER..... 10

6. LOOP FEEDER 14

7. LOCAL SWITCHING..... 18

8. OPERATOR SYSTEMS..... 28

9. COMMON TRANSPORT 31

10. DEDICATED TRANSPORT 34

11. SIGNALING LINK TRANSPORT 47

12. SIGNALING TRANSFER POINTS (STPS)..... 48

13. SERVICE CONTROL POINTS/DATABASES..... 55

14. TANDEM SWITCHING 67

15. DARK FIBER 69

16. ADDITIONAL REQUIREMENTS..... 71

SERVICE DESCRIPTION: UNBUNDLED NETWORK ELEMENTS

1. **Introduction**

This Attachment sets forth the descriptions and requirements for unbundled network elements that BellSouth agrees to offer to Interprise America under this Agreement.

2. **Loop Combination**

2.1 **Definition**

2.1.1 The Loop or Loop Combination is a combination of the network interface device (NID), loop distribution and loop feeder, with or without a loop concentrator/multiplexer. The loop is the physical medium or functional path on which a subscriber's traffic (multiplexed or non-multiplexed, concentrated or non-concentrated) is carried from the MDF, DSX, LGX or DCS in a central office or similar environment (including remote switching modules) up to the termination at the NID at the customer's premise.

2.1.2 The provisioning of service to a customer will require cross-office cabling and cross-connections within the central office to connect the loop to a local switch or to other transmission equipment in co-located space. These cables and cross-connections may be considered part of the loop, the switch or other transmission equipment, or as a separately tariffed element.

2.2 **Technical Requirements**

2.2.1 The Loop or Loop Combination shall be capable of performing transmission and signaling functions associated with all local services including the following (whenever needed by Interprise America and wherever available in the BellSouth network, to provide end-to-end service capability to Interprise America's customer):

2.2.1.1 2-wire voice grade basic telephone services;

2.2.1.2 2-wire ISDN;

2.2.1.3 2-wire CENTREX;

2.2.1.4 2 and 4-wire PBX lines or trunks;

2.2.1.5 2 and 4-wire voice grade private lines and foreign exchange lines;

- 2.2.1.6 4-wire digital data (2.4Kbps through 64Kbps and n times 64Kbps (where $n \leq 24$);
- 2.2.1.7 4-wire DS1 (switched or private line);
2-wire ADSL

2-wire and 4-wire HDSL
- 2.2.1.8 DS-3 rate private lines; and
- 2.2.1.9 Optical SONET OC-n rate private lines.
- 2.2.2 The alternatives for the unbundled loop combination include but are not limited to:
 - 2.2.2.1 Copper twisted pair loop from the NID at the customer's premise to the MDF in the LEC local serving office (LSO).
 - 2.2.2.2 Copper twisted pair distribution from the NID at the customer's premise to a loop concentrator/multiplexer located external to the LSO, with metallic T1 or fiber feeder from the concentrator/multiplexer to an MDF or DSX frame in the LSO (see loop concentrator/multiplexer section for possible variations).
 - 2.2.2.3 Whenever available in the BellSouth network, BellSouth will provide Hybrid fiber coax loop that consists of coax cable from an NID/NIU at the customer's premise to a fiber node, fiber cable from the fiber node to a Host Digital Terminal (HDT) in the LSO, and DS1s from the HDT to a DSX frame in the LSO.
 - 2.2.2.4 DS1 rate loop over a metallic T1 or optical SONET/asynchronous network facility from the NID at the customer's premise to a DSX frame in the LEC LSO.
 - 2.2.2.5 DS3 rate loop over optical SONET/asynchronous network facility from the NID at the customer's premise to a DSX frame or DCS in the LEC LSO.
 - 2.2.2.6 SONET OC-n rate loop from the NID at the customer's premise to a Lightguide Cross-connect (LGX) or DCS in the LSO.
 - 2.2.2.7 Services supported by the loop combinations will include POTS, CENTREX, basic rate ISDN, analog PBX, voice grade private line, and digital data (up to 64 Kb/s). Additional services may include digital PBXs, primary rate ISDN, Nx 64Kb/s, and DS1/DS3 and SONET private lines.

- 2.2.2.8 The loop combination must support the transmission, signaling, performance and interface requirements of the services to be provided over it. It is recognized that the requirements of different services are different, and that a number of types or grades of loops are required to support these services. Services provided over the loop by Interprise America will be consistent with industry standards.
- 2.2.2.9 In some instances, Interprise America will require access to copper twisted pair loop combination unfettered by any intervening equipment (e.g. filters, load coils, range extenders, etc.), so that Interprise America can use the loop combination for a variety of services by attaching appropriate terminal equipment at the ends. Interprise America will determine the type of service that will be provided over the loop combination.
- 2.2.3 The Loop Combination shall be provided to Interprise America in accordance with the following Technical References:
- 2.2.3.1 Bellcore TR-NWT-000057, Functional Criteria for Digital Loop Carrier Systems, Issue 2, January 1993.
- 2.2.3.2 Bellcore TR-NWT-000393, Generic Requirements for ISDN Basic Access Digital Subscriber Lines.
- 2.2.3.3 ANSI T1.106 - 1988, American National Standard for Telecommunications - Digital Hierarchy - Optical Interface Specifications (Single Mode).
- 2.2.3.4 ANSI T1.105 - 1995, American National Standard for Telecommunications - Synchronous Optical Network (SONET) - Basic Description including Multiplex Structure, Rates and Formats.
- 2.2.3.5 ANSI T1.102 - 1993, American National Standard for Telecommunications - Digital Hierarchy - Electrical Interfaces.
- 2.2.3.6 ANSI T1.403 - 1989, American National Standard for Telecommunications - Carrier to Customer Installation, DS1 Metallic Interface Specification.
- 2.2.3.7 Bellcore GR-253-CORE, Synchronous Optical Network Systems (SONET), Common Generic Criteria.
- 2.2.3.8 **DELETED**
- 2.2.3.9 **DELETED**
- 2.2.3.10 **DELETED**

- 2.2.3.11 **DELETED**
- 2.2.3.12 **DELETED**
- 2.2.3.13 Bellcore TR-TSY-000008, Digital Interface Between the SLC 96 Digital Loop Carrier System and a Local Digital Switch, Issue 2, August 1987.
- 2.2.3.14 Bellcore TR-NWT-000303, Integrated Digital Loop Carrier System Generic Requirements, Objectives and Interface, Issue 2, December 1992; Rev.1, December 1993; Supplement 1, December 1993.
- 2.2.3.15 Bellcore TR-TSY-000673, Operations Systems Interface for an IDLC System, (LSSGR) FSD 20-02-2100, Issue 1, September 1989.
- 2.2.3.16 **DELETED**
- 2.2.3.17 **DELETED**
- 2.2.3.18 **DELETED**
- 2.2.3.19 **DELETED**

3. **Integrated Digital Loop Carriers**

Where BellSouth uses integrated Digital Loop Carrier (DLCs) systems to provide the local loop, BellSouth will make alternative arrangements to permit Interprise America to order a contiguous unbundled local loop. These arrangements must provide Interprise America with the capability to serve all of BellSouth's Customers at the same level BellSouth provides itself.

4. **Loop Distribution**

Loop Distribution is composed of two distinct component parts: a Network Interface Device and Distribution Media. Each component part is defined in detail below.

4.1 **Network Interface Device**

4.1.1 **Definition**

- 4.1.1.1 The Network Interface Device (NID) is a single-line termination device or that portion of a multiple-line termination device required to terminate a single line or circuit. The fundamental function of the NID is to establish the official network demarcation point between a carrier and its end-user customer. The NID features two independent chambers or divisions which separate the service provider's network from the customer's inside wiring. Each chamber or division contains the appropriate connection

points or posts to which the service provider, and the end-user customer each make their connections. The NID provides a protective ground connection, and is capable of terminating cables such as twisted pair cable.

- 4.1.1.1.1 BellSouth shall allow Interprise America to access the customer's inside wiring. Such access may take place through either of the following: 1) allow Interprise America to use any existing capacity on BellSouth's NID; or, 2) in instances where spare capacity does not exist, Interprise America may connect its NID to BellSouth's NID only in adherence with FCC rules regarding NID to NID arrangement, until such time as appropriate guidelines for connection to the NID are developed and incorporated within the National Electric Safety Code.
- 4.1.1.2 With respect to multiple-line termination devices, Interprise America shall specify the quantity of NIDs it requires within such device.
- 4.1.1.3 Figure 1 shows a schematic of a NID.

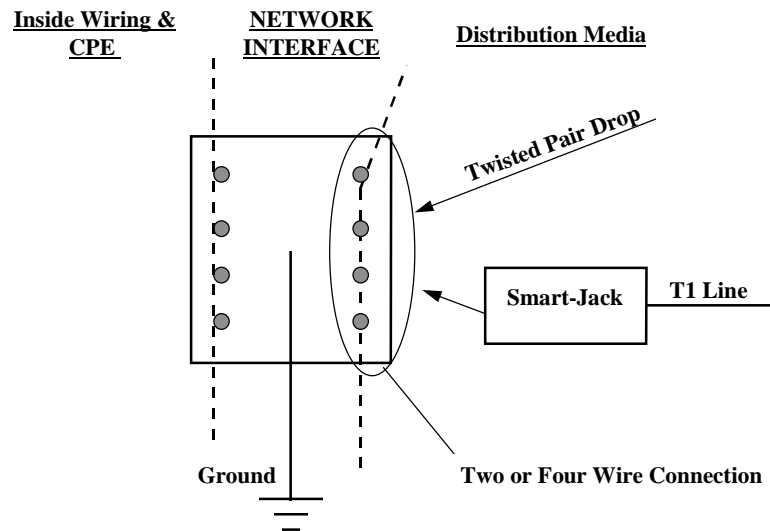

Figure 1 - Network Interface Device

- 4.1.2 **Technical Requirements**
 - 4.1.2.1 The Network Interface Device shall provide a clean, accessible point of connection for the inside wiring and for the Distribution Media and shall maintain a connection to ground that meets the requirements set forth below.

- 4.1.2.2 The NID shall be capable of transferring electrical analog or digital signals between the customer's inside wiring and the Distribution Media.
- 4.1.2.3 All NID posts or connecting points shall be in place, secure, usable and free of any rust or corrosion. The protective ground connection shall exist and be properly installed. The ground wire will also be free of rust or corrosion and have continuity relative to ground.
- 4.1.2.4 The NID shall be capable of withstanding all normal local environmental variations.
- 4.1.2.5 Where the NID is not located in a larger, secure cabinet or closet, the NID shall be protected from physical vandalism. The NID shall be physically accessible to Interprise America designated personnel. In cases where entrance to the customer premises is required to give access to the NID, Interprise America shall obtain entrance permission directly from the customer.
- 4.1.2.6 BellSouth shall offer the NID together with, and separately from the Distribution Media component of Loop Distribution.
- 4.1.3 **Interface Requirements**
- 4.1.3.1 The NID shall be the interface to customers' premises wiring for alternative loop technologies.
- 4.1.3.2 BellSouth shall permit Interprise America to remove any existing terminations to the NID and replace them with terminations designated by Interprise America. BellSouth shall not remove or alter customer inside wiring.
- 4.1.3.3 The NID shall be equal to or better than all of the requirements for NIDs set forth in the following technical references:
 - 4.1.3.3.1 Bellcore Technical Advisory TA-TSY-000120 "Customer Premises or Network Ground Wire";
 - 4.1.3.3.2 Bellcore Generic Requirement GR-49-CORE "Generic Requirements for Outdoor Telephone Network Interface Devices";
 - 4.1.3.3.3 Bellcore Technical Requirement TR-NWT-00239 "Indoor Telephone Network Interfaces";
 - 4.1.3.3.4 Bellcore Technical Requirement TR-NWT-000937 "Generic Requirements for Outdoor and Indoor Building Entrance"; and
 - 4.1.3.3.5 Bellcore Technical Requirement TR-NWT-000133 "Generic Requirements for Network Inside Wiring."

4.2 **Distribution Media**

Any request by Interprise America for unbundling of Distribution Media will be made pursuant to the Bona Fide Request Process identified in Section 1.1. of the General Terms and Conditions.

4.2.1 **Definition**

4.2.1.1 Distribution Media provides connectivity between the NID component of Loop Distribution and the terminal block on the customer-side of a Feeder Distribution Interface (FDI). The FDI is a device that terminates the Distribution Media and the Loop Feeder, and cross-connects them in order to provide a continuous transmission path between the NID and a telephone company central office. For loop plant that contains a Loop Concentrator/Multiplexer, the Distribution Media may terminate at the FDI (if one exists), or at a termination and cross-connect field associated with the Loop Concentrator/Multiplexer. This termination and cross-connect field may be in the form of an outside plant distribution closure, remote terminal or fiber node, or an underground vault.

4.2.1.2 The Distribution Media may be copper twisted pair, coax cable, or single or multi-mode fiber optic cable. A combination that includes two or more of these media is also possible. In certain cases, Interprise America shall require a copper twisted pair Distribution Media even in instances where the Distribution Media for services that BellSouth offers is other than a copper facility.

4.2.2 **Requirements for All Distribution Media**

4.2.2.1 Distribution Media shall be capable of transmitting signals for the following services (as needed by Interprise America to provide end-to-end service capability to its customer):

4.2.2.1.1 2-wire voice grade basic telephone services;

4.2.2.1.2 2-wire ISDN;

4.2.2.1.3 2-wire CENTREX;

4.2.2.1.4 2 and 4-wire PBX lines or trunks;

4.2.2.1.5 2 and 4-wire voice grade private lines and foreign exchange lines;
2-wire ADSL

2-wire and 4-wire HDSL;

4.2.2.1.6 4-wire digital data (2.4Kbps through 64Kbps and n times 64Kbps (where $n \leq 24$); and

- 4.2.2.1.7 4-wire DS1 (switched or private line).
- 4.2.2.2 Distribution Media shall transmit all signaling messages or tones. Where the Distribution Media includes any active elements that terminate any of the signaling messages or tones, these messages or tones shall be reproduced by the Distribution Media at the interfaces to an adjacent Network Element in a format that maintains the integrity of the signaling messages or tones.
- 4.2.2.3 Distribution Media shall support functions associated with provisioning, maintenance and testing of the Distribution Media itself, as well as provide necessary access to provisioning, maintenance and testing functions for Network Elements to which it is associated.
- 4.2.2.4 Distribution Media shall provide performance monitoring of the Distribution Media itself, as well as provide necessary access for performance monitoring for Network Elements to which it is associated.
- 4.2.2.5 Distribution Media shall be equal to or better than all of the applicable requirements set forth in the following technical references:
 - 4.2.2.5.1 Bellcore TR-TSY-000057, "Functional Criteria for Digital Loop Carrier Systems"; and
 - 4.2.2.5.2 Bellcore TR-NWT-000393, "Generic Requirements for ISDN Basic Access Digital Subscriber Lines."
- 4.2.2.6 BellSouth shall provide Interprise America with physical access to, and the right to connect to, the FDI.
 - 4.2.2.6.1 BellSouth shall offer Distribution Media together with, and separately from the NID component of Loop Distribution.
- 4.2.3 **Additional Requirements for Special Copper Distribution Media**

In addition to Distribution Media that supports the requirements in Section 4.2.2 (above), Interprise America may designate Distribution Media to be copper twisted pair which are unfettered by any intervening equipment (*e.g.*, filters, load coils, range extenders) so that Interprise America can use these loops for a variety of services by attaching appropriate terminal equipment at the ends.
- 4.2.4 **Additional Requirements for Fiber Distribution Media**

Fiber optic cable Distribution Media shall be capable of transmitting signals for the following services in addition to the ones under Section 4.2.2.1 above:

 - 4.2.4.1 DS3 rate private line service;

4.2.4.2 Optical SONET OC-n rate private lines (where n is defined in the technical reference in Section 5.2.4.4 of this Attachment 2; and

4.2.4.3 Analog Radio Frequency based services (e.g., Cable Television (CATV)

4.2.5 **Additional Requirements for Coaxial Cable Distribution Media**

Coaxial cable (coax) Distribution Media shall be capable of transmitting signals for the following services in addition to the ones under Section 4.2.2.1 above:

4.2.5.1 Broadband data, either one way or bi-directional, symmetric or asymmetric, at rates between 1.5 Mb/s and 45 Mb/s; and

4.2.5.2 Analog Radio Frequency based services (e.g. CATV).

4.2.6 **Interface Requirements**

4.2.6.1 Signal transfers between the Distribution Media and the NID and an adjacent Network Element shall have levels of degradation that are within the performance requirements set forth in Section 16.2 of this Attachment 2.

4.2.6.2 Distribution Media shall be equal to or better than each of the applicable interface requirements set forth in the following technical references:

4.2.6.2.1 Bellcore TR-NWT-000049, "Generic Requirements for Outdoor Telephone Network Interface Devices," Issued December 1, 1994;

4.2.6.2.2 Bellcore TR-NWT-000057, "Functional Criteria for Digital Loop Carrier Systems," Issued January 2, 1993;

4.2.6.2.3 Bellcore TR-NWT-000393, "Generic Requirements for ISDN Basic Access Digital Subscriber Lines";

4.2.6.2.4 Bellcore TR-NWT-000253, SONET Transport Systems: Common Criteria (A module of TSGR, FR-NWT-000440), Issue 2, December 1991;

5. **Loop Concentrator/Multiplexer**

Any request by Interprise America for unbundling the Loop Concentrator/Multiplexer will be made pursuant to the Bona Fide Request Process identified in Section 1.1. of the General Terms and Conditions.

5.1 **Definition**

- 5.1.1 The Loop Concentrator/Multiplexer is the Network Element that: (1) aggregates lower bit rate or bandwidth signals to higher bit rate or bandwidth signals (multiplexing); (2) disaggregates higher bit rate or bandwidth signals to lower bit rate or bandwidth signals (demultiplexing); (3) aggregates a specified number of signals or channels to fewer channels (concentrating); (4) performs signal conversion, including encoding of signals (*e.g.*, analog to digital and digital to analog signal conversion); and (5) in some instances performs electrical to optical (E/O) conversion.
- 5.1.2 The Loop Concentrator/Multiplexer function may be provided through a Digital Loop Carrier (DLC) system, channel bank, multiplexer or other equipment at which traffic is encoded and decoded, multiplexed and demultiplexed, or concentrated. In cases where this Network Element is required on an integrated DLC, BellSouth will provide it by a universal DLC alternative.
- 5.2 **Technical Requirements**
- 5.2.1 The Loop Concentrator/Multiplexer shall be capable of performing its functions on the signals for the following services, including but not limited to, (as needed by Interprise America to provide end-to-end service capability to its customer):
- 5.2.1.1 2-wire voice grade basic telephone services;
 - 5.2.1.2 2-wire ISDN;
 - 5.2.1.3 2-wire CENTREX;
 - 5.2.1.4 2 and 4-wire PBX lines or trunks;
 - 5.2.1.5 2 and 4-wire voice grade private lines and foreign exchange lines;
 - 5.2.1.6 4-wire digital data (2.4Kbps through 64Kbps and n times 64Kbps (where $n \leq 24$);
2-wire ADSL
2-wire and 4-wire HDSL
 - 5.2.1.7 4-wire DS1 (switched or private line);
 - 5.2.1.8 DS-3 rate private lines;
 - 5.2.1.9 Optical SONET rate private lines; and
 - 5.2.1.10 Coin services

- 5.2.2 The Loop Concentrator/Multiplexer shall perform the following functions as appropriate:
 - 5.2.2.1 Analog to digital signal conversion of both incoming and outgoing (upstream and downstream) analog signals;
 - 5.2.2.2 Multiplexing of the individual digital signals up to higher transmission bit rate signals (*e.g.*, DSO, DS1, DS3, or optical SONET rates) for transport to BellSouth central office through the Loop Feeder; and
 - 5.2.2.3 Concentration of end-user customer signals onto fewer channels of a Loop Feeder. (The concentration ratio provided for the Network Elements requested by Interprise America shall be no higher than the Loop Concentrator/Multiplexer concentration ratio BellSouth uses to provide service to its own customers.)
- 5.2.3 BellSouth shall provide power for the Loop Concentrator/ Multiplexer, through a non-interruptible source if the function is performed in a central office, or from a commercial AC power source with battery backup if the equipment is located outside a central office. Such power shall also adhere to the requirements stated in the Section 2 of Attachment 3.
- 5.2.4 The Loop Concentrator/Multiplexer shall be provided to Interprise America in accordance with industry standards and the following Technical References:
 - 5.2.4.1 Bellcore TR-NWT-000057, Functional Criteria for Digital Loop Carrier Systems, Issue 2, January 1993.
 - 5.2.4.2 Bellcore TR-NWT-000393, Generic Requirements for ISDN Basic Access Digital Subscriber Lines.
 - 5.2.4.3 ANSI T1.106 - 1988, American National Standard for Telecommunications - Digital Hierarchy - Optical Interface Specifications (Single Mode).
 - 5.2.4.4 ANSI T1.105 - 1995, American National Standard for Telecommunications - Synchronous Optical Network (SONET) - Basic Description including Multiplex Structure, Rates and Formats.
 - 5.2.4.5 ANSI T1.102 - 1993, American National Standard for Telecommunications - Digital Hierarchy - Electrical Interfaces.
 - 5.2.4.6 ANSI T1.403- 1989, American National Standard for Telecommunications - Carrier to Customer Installation, DS1 Metallic Interface Specification.

- 5.2.4.7 Bellcore GR-253-CORE, Synchronous Optical Network Systems (SONET), Common Generic Criteria.
- 5.2.4.8
- 5.2.4.9 Bellcore TR-TSY-000008, Digital Interface Between the SLC 96 Digital Loop Carrier System and a Local Digital Switch, Issue 2, August 1987.
- 5.2.4.10 Bellcore TR-NWT-000303, Integrated Digital Loop Carrier System Generic Requirements, Objectives and Interface, Issue 2, December 1992; Rev.1, December 1993; Supplement 1, December 1993.
- 5.2.4.11 Bellcore TR-TSY-000673, Operations Systems Interface for an IDLC System, (LSSGR) FSD 20-02-2100, Issue 1, September 1989.
- 5.3 **Requirements for an Intelligent Loop Concentrator/Multiplexer**
- 5.3.1 In addition to the basic functions described above for the Loop Concentrator/Multiplexer, the Intelligent Loop Concentrator/Multiplexer (IC/M) shall provide facility grooming, facility test functions, format conversion and signaling conversion as appropriate.
- 5.3.2 At Interprise America's option, BellSouth shall provide immediate and continuous configuration and reconfiguration of the channels within the physical interfaces (i.e., of cross connects, as well as direct Interprise America control of such configurations and reconfigurations) on the underlying device that provides such IC/M function.
- 5.3.3 At Interprise America's option, BellSouth shall provide scheduled configuration and reconfiguration of the channels within the physical interfaces (i.e., of cross connects, as well as direct Interprise America control of such configurations and reconfigurations) on the underlying device that provides such IC/M function.
- 5.3.4 The underlying equipment that provides such IC/M function shall continuously monitor protected circuit packs and redundant common equipment.
- 5.3.5 The underlying equipment that provides such IC/M function shall automatically switch to a protection circuit pack on detection of a failure or degradation of normal operation.
- 5.3.6 The underlying equipment that provides such IC/M function shall be equipped with a redundant power supply or a battery back-up.
- 5.3.7 At Interprise America's option, BellSouth shall provide Interprise America with real time performance monitoring and alarm data on IC/M elements that may affect Interprise America's traffic. This includes IC/M hardware

alarm data and facility alarm data on the underlying device that provides such IC/M function.

- 5.3.8 At Interprise America's option, BellSouth shall provide Interprise America with real time ability to initiate tests on the underlying device that provides such IC/M function integrated test equipment as well as other integrated functionality for routine testing and fault isolation.

5.4 **Interface Requirements**

The Loop Concentrator/Multiplexer shall meet the following interface requirements, as appropriate for the configuration that Interprise America designates:

- 5.4.1 The Loop Concentrator/Multiplexer shall provide an analog voice frequency copper twisted pair interface to the local switch (e.g., universal DLC applications), as described in the references in Section 5.2.4 of this Attachment.

- 5.4.2 The Loop Concentrator/Multiplexer shall provide digital 4-wire electrical interfaces to the local digital switch, as described in the references in Section 5.2.4 of this Attachment.

- 5.4.3 The Loop Concentrator/Multiplexer shall provide optical SONET interfaces at rates of OC-N as described in the references in Section 5.2.4 of this Attachment.

- 5.4.4 The Loop Concentrator/Multiplexer shall provide the Bellcore TR-303 DS1 level interface to a Local Digital switch. Loop Concentrator/Multiplexer shall provide Bellcore TR-08 modes 1&2 DS1 interfaces when designated by Interprise America. Such interface requirements are specified in the references in Section 5.2.4 of this Attachment.

- 5.4.5 The Loop Concentrator/Multiplexer shall provide Integrated Network Access (INA) DS1s for non-locally switched or non-switched special services, as described in the references in Section 5.2.4 of this Attachment.

- 5.5 The Intelligent Loop Concentrator/Multiplexer shall be provided to Interprise America in accordance with the Technical References set forth in Sections 5.2.4.13 through 5.2.4.19 above.

6. **Loop Feeder**

Any request by Interprise America for unbundling the Loop Feeder will be made pursuant to the Bona Fide Request Process identified in Section 1.1. of the General Terms and Conditions of this Agreement.

6.1 **Definition**

6.1.1 The Loop Feeder is the Network Element that provides connectivity between (1) a FDI associated with Loop Distribution and a termination point appropriate for the media in a central office, or (2) a Loop Concentrator/Multiplexer provided in a remote terminal and a termination point appropriate for the media in a central office. BellSouth shall provide the necessary cabling between the BellSouth equipment (i.e. FDI) and Interprise America's equipment.

6.1.2 The physical medium of the Loop Feeder may be copper twisted pair, or single or multi-mode fiber as designated by Interprise America and where available in the BellSouth network. In certain cases, BellSouth must provide a copper twisted pair loop even in instances where the medium of the Loop Feeder for services that BellSouth offers is other than a copper facility.

6.2 **Requirements for All Loop Feeder Media**

6.2.1 The Loop Feeder shall be capable of transmitting analog voice frequency, basic rate ISDN, digital data, or analog radio frequency signals, where available in the BellSouth network.

6.2.2 BellSouth shall provide appropriate power for all active elements in the Loop Feeder. BellSouth will provide appropriate power from a central office source, or from a commercial AC source with rectifiers for AC to DC conversion and 8-hour battery back-up when the equipment is located in an outside plant Remote Terminal (RT).

6.3 **Additional Requirements for Special Copper Loop Feeder Medium**

In addition to requirements set forth in Section 6.2 above, and where available in the BellSouth network, Interprise America may require BellSouth to provide copper twisted pair Loop Feeder which are unfettered by any intervening equipment (e.g. filters, load coils, and range extenders), so that Interprise America can use these Loop Feeders for a variety of services by attaching appropriate terminal equipment at the ends.

6.4 **Additional Technical Requirements for DS1 Conditioned Loop Feeder**

In addition to the requirements set forth in Section 6.2 above, and where available in the BellSouth network, Interprise America may designate that the Loop Feeder be conditioned to transport a DS1 signal. The requirements for such transport are defined in the references below in Section 6.6.

6.5 **Additional Technical Requirements for Optical Loop Feeder**

In addition to the requirements set forth in Section 6.2 above, and where available in the BellSouth network, Interprise America may designate that Loop Feeder will transport DS3 and OCn (where n is defined in the technical reference in Section 5.2.4.4. The requirements for such transport are defined in the references below in Section 6.6.

6.6 BellSouth shall offer Loop Feeder in accordance with the requirements set forth in the following Technical References:

6.6.1 **DELETED**

6.6.2 Bellcore Technical Requirement TR-NWT-000499, Issue 5, December 1993, section 7 for DS1 interfaces;

6.6.3 **DELETED**

6.6.4 Bellcore TR-NWT-000057, Functional Criteria for Digital Loop Carrier Systems, Issue 2, January 1993.

6.6.5 Bellcore TR-NWT-000393, Generic Requirements for ISDN Basic Access Digital Subscriber Lines.

6.6.6 ANSI T1.106 - 1988, American National Standard for Telecommunications - Digital Hierarchy - Optical Interface Specifications (Single Mode).

6.6.7 ANSI T1.105 - 1995, American National Standard for Telecommunications - Synchronous Optical Network (SONET) - Basic Description including Multiplex Structure, Rates and Formats.

6.6.8 ANSI T1.102 - 1993, American National Standard for Telecommunications - Digital Hierarchy - Electrical Interfaces.

6.6.9 ANSI T1.403- 1989, American National Standard for Telecommunications - Carrier to Customer Installation, DS1 Metallic Interface Specification.

6.6.10 Bellcore GR-253-CORE, Synchronous Optical Network Systems (SONET), Common Generic Criteria.

6.6.11 **DELETED**

6.6.12 **DELETED**

6.6.13 **DELETED**

6.6.14 **DELETED**

6.7 **Interface Requirements**

6.7.1 The Loop Feeder point of termination (POT) within a BellSouth central office will be as follows:

6.7.1.1 Copper twisted pairs shall terminate on the MDF;

6.7.1.2 DS1 Loop Feeder shall terminate on a DSX1, DCS1/0 or DCS3/1; and

6.7.1.3 Fiber Optic cable shall terminate on a LGX.

6.7.2 When requested by Interprise America:

The Loop Feeder shall provide the analog voice frequency copper twisted pair interface for switched or private line services, as defined in the references in Section 6.6 of this Attachment.

6.7.2.1 Where available in the BellSouth network, the Loop Feeder shall provide the ISDN basic rate interface, as defined in the references in Section 6.6, to the local digital switch designated by Interprise America.

6.7.2.2 The Loop Feeder shall provide digital 4-wire electrical interfaces for digital data services, as defined in the references in Section 6.6 of this Attachment.

6.7.2.3 The Loop Feeder shall provide the standard electrical DS1 interface for applications utilizing DS1 feeder, as defined in the references in Section 6.6 of this Attachment.

6.7.2.4 Where available in the BellSouth network, the Loop Feeder shall provide optical SONET interfaces at the OC-N rates as defined in the references in Section 6.6 of this Attachment.

6.7.3 Loop Feeder shall be equal to or better than each of the applicable interface requirements set forth in the following technical references:

6.7.3.1 Bellcore TR-TSY-000008, Digital Interface Between the SLC 96 Digital Loop Carrier System and a Local Digital Switch, Issue 2, August 1987.

6.7.3.2 Bellcore TR-NWT-000303, Integrated Digital Loop Carrier System Generic Requirements, Objectives and Interface, Issue 2, December 1992; Rev.1, December 1993; Supplement 1, December 1993.

6.7.3.3 **DELETED**

6.7.3.4 **DELETED**

6.7.3.5 **DELETED**

6.7.3.6 **DELETED**

7. **Local Switching**

7.1 **Definition**

7.1.1 Local Switching is the Network Element that provides the functionality required to connect the appropriate originating lines or trunks wired to the Main Distributing Frame (MDF) or Digital Cross Connect (DSX) panel to a desired terminating line or trunk. Such functionality shall include all of the features, functions, and capabilities that the underlying BellSouth switch that is providing such Local Switching function is then capable of providing, including but not limited to: line signaling and signaling software, digit reception, dialed number translations, call screening, routing, recording, call supervision, dial tone, switching, telephone number provisioning, announcements, calling features and capabilities (including call processing), CENTREX, Automatic Call Distributor (ACD), Carrier pre-subscription (e.g. long distance carrier, intraLATA toll), Carrier Identification Code (CIC) portability capabilities, testing and other operational features inherent to the switch and switch software. It also provides access to transport, signaling (ISDN User Part (ISUP) and Transaction Capabilities Application Part (TCAP), and platforms such as adjuncts, Public Safety Systems (911), operator services, Directory Assistance Services and Advanced Intelligent Network (AIN). Remote Switching Module functionality is included in the Local Switching function. The switching capabilities used will be based on the line side features they support. Local Switching will also be capable of routing local, intraLATA, interLATA, and calls to international customer's preferred carrier; call features (e.g., call forwarding) and CENTREX capabilities. Local Switching, including the ability to route to Enterprise America's transport facilities, dedicated facilities and systems, shall be unbundled from all other unbundled Network Elements, i.e., Operator Systems, Common Transport, and Dedicated Transport.

7.1.2 Local Switching also includes Data Switching, which provides:

7.1.2.1 For Frame Relay Service, data services switching functionality that is required to connect the facilities from the User to Network Interface (UNI) to either another UNI or to a communications path at the Network to Network Interface (NNI). In this case, the purpose of Data Switching is to terminate, concentrate, and switch data traffic from Customer Premises Equipment (CPE) in the digital format consistent with the UNI specification for the customer. Data Switching also provides connectivity for the purpose of conveying the customer data to its final destination. The UNI and NNI are industry standard interface specifications that contain physical transmission layer requirements for speeds and line

formats; data link layer requirements for the format of the data units that are passed between the user and the network; and protocol requirements for control procedures used in managing the interface.

7.1.2.2 For ISDN Packet and Circuit Switched Data service, the data switching functionality that is required to connect between industry standard ISDN interfaces. In this case, the purpose of Data Switching is to terminate, concentrate, and switch data traffic from Customer Premises Equipment (CPE) in the digital format consistent with ISDN standards. Data Switching also provides connectivity for the purpose of conveying the customer data to its final destination.

7.2 The requirements set forth in this Section 7.2 apply to Local Switching, but not to the Data Switching function of Local Switching.

7.2.1 **Technical Requirements**

7.2.1.1 Local Switching shall be equal to or better than the requirements for Local Switching set forth in Bellcore's Local Switching Systems General Requirements (FR-NWT-000064).

7.2.1.2 When applicable, BellSouth shall route calls to the appropriate trunk or lines for call origination or termination.

7.2.1.3 BellSouth's local switch shall maintain translations necessary to direct AIN queries for selected lines and dialing sequences to the Interprise America SS7 network.

7.2.1.4 BellSouth's local switch shall accept mutually agreeable AIN responses from the Interprise America SCP via SS7 network interconnection then continue call handling according to instructions contained in the response.

7.2.1.5 BellSouth shall route calls on a per line or per screening class basis to (1) BellSouth platforms providing Network Elements or additional requirements (2) Operator Services platforms, (3) Directory Assistance platforms, and (4) Repair Centers. Any other routing requests by Interprise America will be made pursuant to the Bona Fide Request Process identified in Section 1.1 of this Agreement.

7.2.1.6 BellSouth shall provide unbranded recorded announcements and call progress tones to alert callers of call progress and disposition.

7.2.1.7 BellSouth shall activate service for a Interprise America customer or network interconnection on any of the Local Switching interfaces. This includes provisioning changes to change a customer from BellSouth's

services to Interprise America's services without loss of switch feature functionality as defined in this Agreement.

- 7.2.1.8 BellSouth shall perform routine testing (e.g., Mechanized Loop Tests (MLT) and test calls such as 105, 107 and 108 type calls) and fault isolation on a mutually agreed upon schedule.
- 7.2.1.9 BellSouth shall repair and restore any equipment or any other maintainable component that may adversely impact Local Switching.
- 7.2.1.10 BellSouth shall control congestion points such as those caused by radio station call-ins, and network routing abnormalities. All traffic shall be restricted in a non discriminatory manner.
- 7.2.1.11 BellSouth shall perform manual call trace and permit customer originated call trace.
- 7.2.1.12 **DELETED**
- 7.2.1.13 For Local Switching used as 911 Tandems, BellSouth shall allow interconnection from Interprise America local switching elements and BellSouth shall route the calls to the appropriate Public Safety Access Point (PSAP).
- 7.2.1.14 Special Services provided by BellSouth will include the following:
 - 7.2.1.14.1 Essential Service Lines;
 - 7.2.1.14.2 Telephone Service Prioritization;
 - 7.2.1.14.3 Related services for handicapped;
 - 7.2.1.14.4 Soft dial tone where required by law; and
 - 7.2.1.14.5 Any other service required by law.
- 7.2.1.15 BellSouth shall provide Switching Service Point (SSP) capabilities and signaling software to interconnect the signaling links destined to the Signaling Transfer Point Switch (STPS). These capabilities shall adhere to Bellcore specifications - TCAP (GR-1432-CORE), ISUP (GR-905-CORE), Call Management (GR-1429-CORE), Switched Fractional DS1 (GR-1357-CORE), Toll Free Service (GR-1428-CORE), Calling Name (GR-1597-CORE), Line Information Database (GR-954-CORE), and Advanced Intelligent Network (GR-2863-CORE).
- 7.2.1.16 BellSouth shall provide interfaces to adjuncts through Bellcore standard interfaces. These adjuncts can include, but are not limited to, the Service Circuit Node and Automatic Call Distributors.

- 7.2.1.17 BellSouth shall provide performance data regarding a customer line, traffic characteristics or other measurable elements to Interprise America, upon a reasonable request from Interprise America.
- 7.2.1.18 BellSouth shall offer Local Switching that provides feature offerings at parity to those provided by BellSouth to itself or any other party. Such feature offerings shall include but are not limited to:
- 7.2.1.18.1 Basic and primary rate ISDN;
 - 7.2.1.18.2 Residential features;
 - 7.2.1.18.3 Customer Local Area Signaling Services (CLASS/LASS);
 - 7.2.1.18.4 CENTREX (including equivalent administrative capabilities, such as customer accessible reconfiguration and detailed message recording); and
 - 7.2.1.18.5 Advanced intelligent network triggers supporting Interprise America and BellSouth service applications.
BellSouth shall offer to Interprise America all AIN triggers which are supported by BellSouth for offering AIN-based services in accordance with the technical references in Section 7.2.1.23 of this Attachment. Triggers that are currently available include:
 - 7.2.1.18.5.1 Off-Hook Immediate
 - 7.2.1.18.5.2 Off-Hook Delay
 - 7.2.1.18.5.3 Termination Attempt
 - 7.2.1.18.5.4 3/6/10 Public Office Dialing Plan
 - 7.2.1.18.5.5 Feature Code Dialing
 - 7.2.1.18.5.6 Customer Dialing Plan
 - 7.2.1.18.6 When the following triggers are supported by BellSouth, BellSouth will make these triggers available to Interprise America:
 - 7.2.1.18.6.1 Private EAMF Trunk
 - 7.2.1.18.6.2 Shared Interoffice Trunk (EAMF, SS7)
 - 7.2.1.18.6.3 N11
 - 7.2.1.18.6.4 Automatic Route Selection

- 7.2.1.19 BellSouth shall assign each Interprise America customer line the class of service designated by Interprise America (e.g., using line class codes or other switch specific provisioning methods), and shall route directory assistance calls from Interprise America customers to Interprise America directory assistance operators at Interprise America's option.
- 7.2.1.20 BellSouth shall assign each Interprise America customer line the class of services designated by Interprise America (e.g., using line class codes or other switch specific provisioning methods) and shall route operator calls from Interprise America customers to Interprise America operators at Interprise America's option. For example, BellSouth may translate 0- and 0+ intraLATA traffic, and route the call through appropriate trunks to a Interprise America Operator Services Position System (OSPS). Calls from Local Switching must pass the ANI-II digits unchanged.
- 7.2.1.21 If Interprise America requests disconnection of the Local Switching element, BellSouth shall disconnect promptly and remove all appropriate translations from BellSouth facilities.
- 7.2.1.22 If a Interprise America customer subscribes to Interprise America provided voice mail and messaging services, BellSouth shall redirect incoming calls to the Interprise America system based upon presubscribed service arrangements (e.g., busy, don't answer, number of rings). In addition, BellSouth shall provide a Standard Message Desk Interface-Enhanced (SMDI-E) interface to the Interprise America system. BellSouth shall support the Inter-switch Voice Messaging Service (IVMS) capability.
- 7.2.1.23 Local Switching shall be offered in accordance with the requirements of the following technical references:
- 7.2.1.23.1 BellCore GR-1298-CORE, AIN Switching System Generic Requirements, as implemented in BellSouth's switching equipment;
- 7.2.1.23.2 BellCore GR-1299-CORE, AIN Switch-Service Control Point (SCP)/Adjunct Interface Generic Requirements;
- 7.2.1.23.3 BellCore TR-NWT-001284, AIN 0.1 Switching System Generic Requirements;
- 7.2.1.23.4 BellCore SR-NWT-002247, AIN Release 1 Update.
- 7.2.2 **Interface Requirements**
- 7.2.2.1 BellSouth shall provide the following interfaces to loops:

- 7.2.2.2 Standard Tip/Ring interface including loopstart or groundstart, on-hook signaling (e.g., for calling number, calling name and message waiting lamp);
- 7.2.2.3 Coin phone signaling;
- 7.2.2.4 Basic Rate Interface ISDN adhering to appropriate Bellcore Technical Requirements;
- 7.2.2.5 Two-wire analog interface to PBX;
- 7.2.2.5.1 Four-wire analog interface to PBX;
- 7.2.2.6 Four-wire DS1 interface to PBX or customer provided equipment (e.g. computers and voice response systems);
- 7.2.2.7 Primary Rate ISDN to PBX adhering to ANSI standards Q.931, Q.932 and appropriate Bellcore Technical Requirements;
- 7.2.2.8 Switched Fractional DS1 with capabilities to configure Nx64 channels (where N = 1 to 24); and
- 7.2.2.9 Loops adhering to Bellcore TR-NWT-08 and TR-NWT-303 specifications to interconnect Digital Loop Carriers.
- 7.2.2.10 BellSouth shall provide access to the following but not limited to:
- 7.2.2.11 SS7 Signaling Network or Multi-Frequency trunking if requested by Interprise America;
- 7.2.2.12 Interface to Interprise America operator services systems or Operator Services through appropriate trunk interconnections for the system; and
- 7.2.2.13 Interface to Interprise America directory assistance services through the Interprise America switched network or to Directory Assistance Services through the appropriate trunk interconnections for the system; and 950 access or other Interprise America required access to interexchange carriers as requested through appropriate trunk interfaces.

7.3 **Data Switching**

The requirements set forth in this Section 7.3 apply only to the Data Switching function of Local Switching.

7.3.1 **Data Switching Technical Requirements**

- 7.3.1.1 Data Switching includes the necessary cross-office connectivity to the DSX or other appropriate connection point where interconnection to transport, or a cross-connect device can occur. Wherever Data

Switching interconnects across network boundaries, it shall be in accordance with Network-to-Network Interface standards.

7.3.1.2 Frame Relay Functional Requirements

- 7.3.1.3 Frame Relay Data Switching shall provide Permanent Virtual Circuits (PVCs) in accordance with the core protocol in ANSI Standard T1.618 ("Core aspects of Frame Protocol for use with Frame Relay Bearer Service," ANSI Standard T1.618, October 1991).
- 7.3.1.4 Control procedures for PVC management that shall be provided by Data Switching over the UNI include at least the Local Management interface (LMI) (as described in "Frame Relay Specification with Extensions," Rev 1.0, Digital Equipment Corporation, Northern Telecom, Inc., and StrataCom, Inc., September 18, 1990), ANSI Standard T1.617: Annex D ("Signaling Specification for Frame Relay Bearer Service," ANSI Standard T1.617, October 1991), and ITU-T Recommendation Q.933: Annex A ("Digital subscriber Signaling System No. 1 -- Signaling specification for frame mode bearer service," ITU-T Recommendation Q.933, March 1993) specifications.
- 7.3.1.5 Data Switching provided to Interprise America shall be given equal priority to BellSouth's own traffic during overflow and congestion conditions. To control the flow of data through the network and to prevent congestion of shared resources, Data Switching shall perform traffic management and policing functions on the ingress of data (flowing from customer into the network) and the egress of data (flowing from the network out to the customer). Traffic management is the mechanism used by Data Switching to prevent and reduce congestion within the network, such as buffering data and discarding data when buffers overflow, and may be performed on ingress or egress. Traffic policing is the enforcement by Data Switching of the contracted rate for the ingress of data, described in terms of several parameters such as Peak Rate, Committed Rate, and Burst Size. Traffic management and policing performed at ingress and egress on Interprise America's traffic shall be at parity with that performed on BellSouth's traffic.
- 7.3.1.6 As systems development allows, Data Switching shall provide remote data access to integrated test equipment and other integrated functionality on a demand basis in accordance with the following:
- 7.3.1.7 Real-time, remote data access to systems that enable the determination of Data Link Connection Identifiers (DLCIs) used by a PVC;
- 7.3.1.8 Real-time, remote data access to performance monitoring and alarm data on events affecting (or potentially affecting) Interprise America's traffic; and

- 7.3.1.9 Real-time, remote data access to maintenance systems to enable end-to-end (customer site-to-customer site) performance and error testing.
- 7.3.1.10 BellSouth shall provision and maintain the underlying facilities required to provide Data Switching.
- 7.3.1.11 **Frame Relay Interface Requirements**
- 7.3.1.12 From Customer Premises Equipment (CPE), Interprise America's Customers may interconnect to Data Switching using the transmission speeds, formats, and protocols as specified in the Frame Relay Forum Implementation Agreement 1 (FRF-1.1) ("User-to-Network Implementation Agreement (UNI)," FRF-1.1, Frame Relay Forum Technical Committee, January 18, 1996) and the standards cited in that document for the physical layer, data transfer, and control procedures. This includes, but is not limited to, access circuits at fractional T1 rates (56Kbps, Nx64 Kbps, (where N is 1 to 24)), T1, and T3.
- 7.3.1.13 Each T1 UNI interface port shall provide at least 250 PVCs or the appropriate number of PVC's allowed by the platform.
- 7.3.1.14 T1 interfaces shall be provided using Extended SuperFrame (ESF) format, for enhanced error monitoring and to aid in sectionalizing problems.
- 7.3.1.15 **NNI Interface B Requirements**
- 7.3.1.16 Data Switching shall interconnect across network boundaries using the Network-to-Network Interface standards as specified in Frame Relay Forum Implementation Agreement 2 (FRF-2.1) ("Network -to-Network Implementation Agreement (NNI)," FRF-2.1, Frame Relay Forum Technical Committee, July 10, 1995) for the physical layer, data transfer, and control (signaling) procedures. This standard includes both DS1 and DS3 among its listed physical interface formats.
- 7.3.1.17 Each T1 NNI should be capable of providing at least 200 PVCs; each T3 NNI should be capable of providing at least 1700 PVCs or the appropriate number of PVC's allowed by the platform.
- 7.3.1.18 **DELETED**
- 7.3.1.19 **DELETED**
- 7.3.1.20 ATM Functional Requirements: When ATM functionality becomes available, BellSouth will provide these functions to Interprise America. In addition BellSouth agrees to conform to industry standard (e.g. Bellcore standards).

7.3.1.20.1 DELETED
7.3.1.20.2 DELETED
7.3.1.20.3 DELETED
7.3.1.20.3.1 DELETED
7.3.1.20.3.2 DELETED
7.3.1.20.3.3 DELETED
7.3.1.20.4 DELETED
7.3.1.20.5 DELETED
7.3.1.21 DELETED
7.3.1.21.1 DELETED
7.3.1.21.1.1 DELETED
7.3.1.21.1.2 DELETED
7.3.1.21.2 DELETED
7.3.1.21.3 DELETED
7.3.1.21.4 DELETED
7.3.1.21.4.1 DELETED
7.3.1.21.4.2 DELETED
7.3.1.21.4.3 DELETED
7.3.1.21.4.4 DELETED
7.3.1.21.4.5 DELETED
7.3.1.21.4.6 DELETED
7.3.1.21.5 DELETED
7.3.1.21.6 DELETED
7.3.1.21.6.1 DELETED
7.3.1.21.6.2 DELETED

7.3.1.21.6.3 **DELETED**

7.3.1.21.6.4 **DELETED**

7.3.1.21.6.5 **DELETED**

7.3.1.21.6.6 **DELETED**

7.3.1.21.6.7 **DELETED**

7.3.1.21.6.7.1 **DELETED**

7.3.1.21.6.7.2 **DELETED**

7.3.1.21.6.7.3 **DELETED**

7.3.1.21.6.8 **DELETED**

7.3.1.22 **Integrated Services Digital Network (ISDN)**

Integrated Services Digital Network (ISDN) is defined in two variations. The first variation is Basic Rate ISDN (BRI). BRI consists of 2 Bearer (B) Channels and one Data (D) Channel. The second variation is Primary Rate ISDN (PRI). PRI consists of 23 B Channels and one D Channel. Both BRI and PRI B Channels may be used for voice, Circuit Switched Data (CSD) or Packet Switched Data (PSD). The BRI D Channel may be used for call related signaling, non-call related signaling or packet switched data. The PRI D Channel may be used for call related signaling.

7.3.1.22.1 Technical Requirements - ISDN

7.3.1.22.2 BellSouth shall offer Data Switching providing ISDN that, at a minimum:

7.3.1.22.3 Provides integrated packet handling capabilities;

7.3.1.22.4 Allows for full 2B+D Channel functionality for BRI; and

7.3.1.22.5 Allows for full 23B+D Channel functionality for PRI.

7.3.1.22.6 Each B Channel shall allow for voice, 64Kbs CSD, and PSD of 128 logical channels at minimum speeds of 19Kbs throughput of each logical channel up to the total capacity of the B Channel.

7.3.1.22.7 Each B Channel shall provide capabilities for alternate voice and data on a per call basis.

7.3.1.22.8 The BRI D Channel shall allow for call associated signaling, non-call associated signaling and PSD of 16 logical channels at minimum speeds

of 9.6 Kbs throughput of each logical channel up to the total capacity of the D Channel.

- 7.3.1.22.9 The PRI D Channel shall allow for call associated signaling.
- 7.3.1.22.10 Interface Requirements - ISDN
- 7.3.1.22.11 BellSouth shall provide the BRI U interface using 2 wire copper loops in accordance with TR-NWT-000393, January 1991, *Generic Requirements for ISDN Basic Access Digital Subscriber Lines*.
- 7.3.1.22.12 BellSouth shall provide the BRI interface using Digital Subscriber Loops adhering to Bellcore TR-NWT-303 specifications to interconnect Digital Loop Carriers.
- 7.3.1.22.13 BellSouth shall offer PSD interfaces adhering to the X.25, S.75 and S.75' ANSI and Bellcore requirements.
- 7.3.1.22.14 BellSouth shall offer PSD trunk interfaces operating at 56Kbs.

8. **Operator Systems**

8.1 **Definition**

Operator Systems is the Network Element that provides operator and automated call handling and billing, special services, customer telephone listings and optional call completion services. The Operator Systems, Network Element provides two types of functions: Operator Service functions and Directory Assistance Service functions, each of which are described in detail below.

8.2 **Operator Service**

8.2.1 **Definition**

Operator Service provides: (1) operator handling for call completion (for example, collect, third number billing, and manual credit card calls), (2) operator or automated assistance for billing after the customer has dialed the called number (for example, credit card calls); and (3) special services including but not limited to Busy Line Verification and Emergency Line Interrupt (ELI), Emergency Agency Call, Operator-assisted Directory Assistance, and Rate Quotes.

8.2.2 **Requirements**

- 8.2.2.1 When Interprise America requests BellSouth to provide Operator Services, the following requirements apply:

- 8.2.2.1.1 BellSouth shall complete 0+ and 0- dialed local calls.
- 8.2.2.1.2 BellSouth shall complete 0+ intraLATA toll calls.
- 8.2.2.1.3 BellSouth shall complete calls that are billed to a Interprise America customer's calling card that can be validated by BellSouth.
- 8.2.2.1.4 BellSouth shall complete person-to-person calls.
- 8.2.2.1.5 BellSouth shall complete collect calls.
- 8.2.2.1.6 BellSouth shall provide the capability for callers to bill to a third party and complete such calls.
- 8.2.2.1.7 BellSouth shall complete station-to-station calls.
- 8.2.2.1.8 BellSouth shall process emergency calls.
- 8.2.2.1.9 BellSouth shall process Busy Line Verify and Emergency Line Interrupt requests.
- 8.2.2.1.10 BellSouth shall process emergency call trace, as they do for their Customers prior to the Effective Date. Call must originate from a 911 provider.
- 8.2.2.1.11 BellSouth shall process operator-assisted directory assistance calls.
- 8.2.2.1.12 **DELETED**
- 8.2.2.1.13 **DELETED**
- 8.2.2.1.14 BellSouth will provide the ability for a Interprise America Customer to reach a "live" operator on a 0-call.
- 8.2.2.1.15 BellSouth shall brand Operator Service as specified by Interprise America in Section 18 of the General Terms and Conditions of this Agreement.
- 8.2.2.2 **DELETED**
- 8.2.2.3 BellSouth shall adhere to equal access requirements, providing Interprise America local customers the same IXC access as provided to BellSouth customers.
- 8.2.2.4 BellSouth shall exercise at least the same level of fraud control in providing Operator Service to Interprise America that BellSouth provides for its own operator service.

8.2.2.5 BellSouth shall perform Billed Number Screening when handling Collect, Person-to-Person, and Billed-to-Third-Party calls.

8.2.2.6 **DELETED**

8.2.2.7 BellSouth shall direct customer account and other similar inquiries to the customer service center designated by Interprise America.

8.2.2.8 BellSouth shall provide an electronic feed of customer call records in "EMR" format to Interprise America in accordance with the time schedule designated by Interprise America.

8.2.2.9 **DELETED**

8.2.3 **Interface Requirements:**

With respect to Operator Services for calls that originate on local switching capability provided by or on behalf of Interprise America, the interface requirements shall conform to the then current established system interface specifications for the platform used to provide Operator Service and the interface shall conform to industry standards.

8.3 **Directory Assistance Service**

8.3.1 **Definition**

Directory Assistance Service provides local customer telephone number listings with the option to complete the call at the callers direction separate and distinct from local switching.

8.3.2 **Requirements**

8.3.2.1 Directory Assistance Service shall provide up to two listing requests per call. If available and if requested by Interprise America's customer, BellSouth shall provide caller-optional directory assistance call completion service to one of the provided listings, equal to that which BellSouth provides its customers. If not available, Interprise America may request such requirement pursuant to the Bona Fide Request Process provided for in Attachment 14 of this Agreement.

8.3.2.2 BellSouth shall brand Directory Assistance Service as specified by Interprise America in Section 18 of the General Terms and Conditions of this Agreement.

8.3.2.3 **DELETED**

8.3.2.4 **DELETED**

8.3.2.5 **Directory Assistance Service Updates**

- 8.3.2.5.1 BellSouth shall update customer listings changes daily. These changes include:
 - 8.3.2.5.1.1 New customer connections: BellSouth will provide service to Interprise America that is equal to the service it provides to itself and its customers;
 - 8.3.2.5.1.2 Customer disconnections: BellSouth will provide service to Interprise America that is equal to the service it provides to itself and its customers; and
 - 8.3.2.5.1.3 Customer address changes: BellSouth will provide service to Interprise America that is equal to the service it provides to itself and its customers;
- 8.3.2.6 These updates shall also be provided for non-listed and non-published numbers for use in emergencies.

9. **Common Transport**

9.1 **Definition**

Common Transport is an interoffice transmission path between BellSouth Network Elements (illustrated in Figure 2). Where BellSouth Network Elements are connected by intra-office wiring, such wiring is provided as a part of the Network Elements and is not Common Transport. Common Transport consists of BellSouth inter-office transport facilities and is unbundled from local switching.

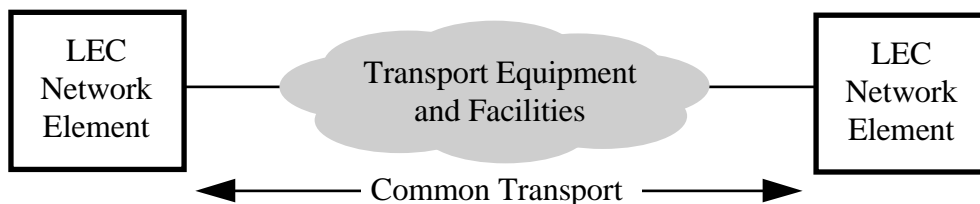

Figure 2

9.2 **Technical Requirements**

- 9.2.1 Common Transport provided on DS1 or VT1.5 circuits, shall, at a minimum, meet the performance, availability, jitter, and delay requirements specified for Central Office to Central Office “CO to CO” connections in the technical reference set forth in Section 9.2.4.31 of this Attachment 2.
- 9.2.2 Common Transport provided on DS3 circuits, STS-1 circuits, and higher transmission bit rate circuits, Common Transport shall, at a minimum, meet the performance, availability, jitter, and delay requirements

specified for Central Office to Central Office "CO to CO" connections in the technical reference set forth in Section 9.2.4.30 of this Attachment 2.

- 9.2.3 BellSouth shall be responsible for the engineering, provisioning, and maintenance of the underlying equipment and facilities that are used to provide Common Transport.
- 9.2.4 At a minimum, Common Transport shall meet all of the requirements set forth in the following technical references (as applicable for the transport technology being used):
 - 9.2.4.1 ANSI T1.101-1994, American National Standard for Telecommunications - Synchronization Interface Standard Performance and Availability;
 - 9.2.4.2 ANSI T1.102-1993, American National Standard for Telecommunications - Digital Hierarchy - Electrical Interfaces;
 - 9.2.4.3 ANSI T1.102.01-199x, American National Standard for Telecommunications - Digital Hierarchy - VT1.5;
 - 9.2.4.4 ANSI T1.105-1995, American National Standard for Telecommunications - Synchronous Optical Network (SONET) - Basic Description including Multiplex Structure, Rates and Formats;
 - 9.2.4.5 ANSI T1.105.01-1995, American National Standard for Telecommunications - Synchronous Optical Network (SONET) - Automatic Protection Switching;
 - 9.2.4.6 ANSI T1.105.02-1995, American National Standard for Telecommunications - Synchronous Optical Network (SONET) - Payload Mappings;
 - 9.2.4.7 ANSI T1.105.03-1994, American National Standard for Telecommunications - Synchronous Optical Network (SONET) - Jitter at Network Interfaces;
 - 9.2.4.8 ANSI T1.105.03a-1995, American National Standard for Telecommunications - Synchronous Optical Network (SONET): Jitter at Network Interfaces - DS1 Supplement;
 - 9.2.4.9 ANSI T1.105.05-1994, American National Standard for Telecommunications - Synchronous Optical Network (SONET) - Tandem Connection;
 - 9.2.4.10 ANSI T1.105.06-199x, American National Standard for Telecommunications - Synchronous Optical Network (SONET) - Physical Layer Specifications;

- 9.2.4.11 ANSI T1.105.07-199x, American National Standard for Telecommunications - Synchronous Optical Network (SONET) - Sub STS-1 Interface Rates and Formats;
- 9.2.4.12 ANSI T1.105.09-199x, American National Standard for Telecommunications - Synchronous Optical Network (SONET) - Network Element Timing and Synchronization;
- 9.2.4.13 ANSI T1.106-1988, American National Standard for Telecommunications - Digital Hierarchy - Optical Interface Specifications (Single Mode);
- 9.2.4.14 ANSI T1.107-1988, American National Standard for Telecommunications - Digital Hierarchy - Formats Specifications;
- 9.2.4.15 ANSI T1.107a-1990 - American National Standard for Telecommunications - Digital Hierarchy - Supplement to Formats Specifications (DS3 Format Applications);
- 9.2.4.16 ANSI T1.107b-1991 - American National Standard for Telecommunications - Digital Hierarchy - Supplement to Formats Specifications;
- 9.2.4.17 ANSI T1.117-1991, American National Standard for Telecommunications - Digital Hierarchy - Optical Interface Specifications (SONET) (Single Mode - Short Reach);
- 9.2.4.18 ANSI T1.403-1989, Carrier to Customer Installation, DS1 Metallic Interface Specification;
- 9.2.4.19 ANSI T1.404-1994, Network-to-Customer Installation - DS3 Metallic Interface Specification;
- 9.2.4.20 ITU Recommendation G.707, Network node interface for the synchronous digital hierarchy (SDH);
- 9.2.4.21 ITU Recommendation G.704, Synchronous frame structures used at 1544, 6312, 2048, 8488 and 44736 kbit/s hierarchical levels;
- 9.2.4.22 Bellcore FR-440 and TR-NWT-000499, Transport Systems Generic Requirements (TSGR): Common Requirements;
- 9.2.4.23 Bellcore GR-820-CORE, Generic Transmission Surveillance: DS1 & DS3 Performance;
- 9.2.4.24 Bellcore GR-253-CORE, Synchronous Optical Network Systems (SONET); Common Generic Criteria;

- 9.2.4.25 Bellcore TR-NWT 000507, Transmission, Section 7, Issue 5 (Bellcore, December 1993). (A module of LSSGR, FR-NWT-000064.);
- 9.2.4.26 Bellcore TR-NWT-000776, Network Interface Description for ISDN Customer Access;
- 9.2.4.27 Bellcore TR-INS-000342, High-Capacity Digital Special Access Service-Transmission Parameter Limits and Interface Combinations, Issue 1 February 1991;
- 9.2.4.28 Bellcore ST-TEC 000052, Telecommunications Transmission Engineering Textbook, Volume 2: Facilities, Third Edition, Issue I May 1989;
- 9.2.4.29 Bellcore ST-TEC-000051, Telecommunications Transmission Engineering Textbook Volume 1: Principles, Third Edition. Issue 1 August 1987;

10. **Dedicated Transport**

10.1 **Definition**

10.1.1.1 Dedicated Transport is an interoffice transmission path between Interprise America designated locations unbundled from local switching. Interprise America designated locations may include BellSouth central offices or other equipment locations, Interprise America network components, other carrier network components, or customer premises. Dedicated Transport is depicted below in Figure 3.

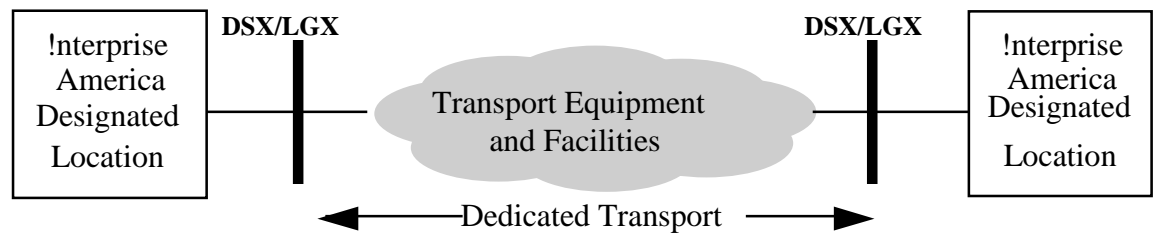

Figure 3

- 10.1.2 BellSouth shall offer Dedicated Transport in each of the following ways:
 - 10.1.2.1 As capacity on a shared circuit.
 - 10.1.2.2 As a circuit (e.g., DS1, DS3, STS-1) dedicated to Interprise America.
 - 10.1.2.3 As a system (i.e., the equipment and facilities used to provide Dedicated Transport such as SONET ring) dedicated to Interprise America.

- 10.1.3 When Dedicated Transport is provided as a circuit or as capacity on a shared circuit, it shall include (as appropriate):
 - 10.1.3.1 Multiplexing functionality;
 - 10.1.3.2 Grooming functionality; and
 - 10.1.3.3 Redundant equipment and facilities necessary to support protection and restoration.
- 10.1.4 When Dedicated Transport is provided as a system it shall include:
 - 10.1.4.1 Transmission equipment such as multiplexers, line terminating equipment, amplifiers, and regenerators;
 - 10.1.4.2 Inter-office transmission facilities such as optical fiber, copper twisted pair, and coaxial cable;
 - 10.1.4.3 Redundant equipment and facilities necessary to support protection and restoration; and
 - 10.1.4.4 Dedicated Transport includes the Digital Cross-Connect System (DCS) functionality as an option. DCS is described below in Section 10.5 of this Attachment.

10.2 **Technical Requirements**

This Section sets forth technical requirements for all Dedicated Transport.

- 10.2.1 When BellSouth provides Dedicated Transport as a circuit or a system, the entire designated transmission circuit or system (*e.g.*, DS1, DS3, STS-1) shall be dedicated to Interprise America designated traffic.
- 10.2.2 BellSouth shall offer Dedicated Transport in all technologies that become available during the life of the contract including, but not limited to, DS1 and DS3 transport systems, SONET (or SDH) Bi-directional Line Switched Rings, SONET (or SDH) Unidirectional Path Switched Rings, and SONET (or SDH) point-to-point transport systems (including linear add-drop systems), at all available transmission bit rates.
- 10.2.3 For DS1 or VT1.5 circuits, Dedicated Transport shall, at a minimum, meet the performance, availability, jitter, and delay requirements specified for Customer Interface to Central Office "CI to CO" connections in the technical references set forth in Section 10.4 of this Attachment.
- 10.2.4 For DS3 circuits, STS-1 circuits, and higher rate circuits, Dedicated Transport shall, at a minimum, meet the performance, availability, jitter,

and delay requirements specified for Customer Interface to Central Office "CI to CO" connections in the technical references set forth in Section 10.4 of this Attachment.

- 10.2.5 When requested by Interprise America, Dedicated Transport shall provide physical diversity. Physical diversity means that two circuits are provisioned in such a way that no single failure of facilities or equipment will cause a failure on both circuits.
- 10.2.6 When physical diversity is requested by Interprise America, BellSouth shall provide the maximum feasible physical separation between intra-office and inter-office transmission paths (unless otherwise agreed by Interprise America).
- 10.2.7 Upon Interprise America's request, BellSouth shall provide real time and continuous remote access to performance monitoring and alarm data affecting, or potentially affecting, Interprise America's traffic.
- 10.2.8 BellSouth shall offer the following interface transmission rates for Dedicated Transport:
 - 10.2.8.1 DS1 (Extended SuperFrame - ESF, D4, and unframed applications shall be provided);
 - 10.2.8.2 DS3 (C-bit Parity, M13, and unframed applications shall be provided);
 - 10.2.8.3 SONET standard interface rates in accordance with ANSI T1.105 and ANSI T1.105.07 and physical interfaces per ANSI T1.106.06 (including referenced interfaces). In particular, VT1.5 based STS-1s will be the interface at a Interprise America service node.
 - 10.2.8.4 SDH Standard interface rates in accordance with International Telecommunications Union (ITU) Recommendation G.707 and Plesiochronous Digital Hierarchy (PDH) rates per ITU Recommendation G.704.
- 10.2.9 BellSouth shall provide cross-office wiring up to a suitable Point of Termination (POT) between Dedicated Transport and Interprise America designated equipment. BellSouth shall provide the following equipment for the physical POT:
 - 10.2.9.1 DSX1 for DS1s or VT1.5s;
 - 10.2.9.2 DSX3 for DS3s or STS-1s; and
 - 10.2.9.3 LGX for optical signals (e.g., OC-3 and OC-12)
- 10.2.10 **DELETED**

- 10.2.11 When Dedicated Transport is provided as a system, BellSouth shall design the system according to Interprise America's architectural requirements. This includes, but is not limited to:
1. Facility routing and termination points (including diversity requirements),
 2. Interface selection among those available on the system,
 3. System provisionable parameters (e.g. protection switching thresholds). This does not include specification of the vendor to be used by BellSouth, except where mutually agreed.
- 10.2.12 Upon Interprise America's request, BellSouth shall provide Interprise America with electronic provisioning control of Interprise America rings. As system development allows, BellSouth shall provide this functionality in other transport systems (e.g. linear transport systems.)
- 10.2.13 BellSouth shall offer Dedicated Transport together with and separately from DCS.
- 10.3 Technical Requirements for Dedicated Transport Using SONET technology.
- This Section sets forth additional technical requirements for Dedicated Transport using SONET technology including rings, point-to-point systems, and linear add-drop systems.
- 10.3.1 All SONET Dedicated Transport provided as a system shall:
- 10.3.1.1 Be synchronized from both a primary and secondary Stratum 1 level timing source. Additional detail on synchronization requirements are given in Section 16.4 of this Attachment 2.
 - 10.3.1.2 Provide SONET standard interfaces which properly interwork with SONET standard equipment from other vendors. This includes, but is not limited to, SONET standard Section, Line, and Path performance monitoring, maintenance signals, alarms, and data channels.
 - 10.3.1.3 Provide Data Communications Channel (DCC) or equivalent connectivity through the SONET transport system. Dedicated Transport provided over a SONET transport system shall be capable of routing DCC messages between Interprise America SONET network components connected to the Dedicated Transport. For example, if Interprise America leases a SONET ring from BellSouth, that ring shall support DCC message routing between Interprise America SONET network components connected to the ring.
 - 10.3.1.4 Support the following performance requirements for each circuit (STS-1, DS1, DS3, etc.):

- 10.3.1.5 No more than 10 Errored Seconds Per Day (Errored Seconds are defined in the technical reference at Section 10.4.5 of this Attachment); and
- 10.3.1.6 No more than 1 Severely Errored Second Per Day (Severely Errored Seconds are defined in the technical reference at Section 10.4.5 of this Attachment).
- 10.3.1.7 All SONET rings shall:
- 10.3.1.8 Be provisioned on physically diverse fiber optic cables (including separate building entrances where available and diversely routed intra-office wiring). "Diversely routed" shall be interpreted as the maximum feasible physical separation between transmission paths, unless otherwise agreed by Interprise America.
- 10.3.1.9 Support dual ring interworking per SONET Standards.
- 10.3.1.10 To the extent technically feasible, BellSouth shall provide the necessary redundancy in optics, electronics, and transmission paths (including intra-office wiring) such that no single failure will cause a service interruption.
- 10.3.1.11 Provide the ability to disable ring protection switching at Interprise America's direction (selective protection lock-out), if BellSouth's SONET equipment provides this functionality. This requirement applies to line switched rings only.
- 10.3.1.12 Provide the ability to use the protection channels to carry traffic (extra traffic), if BellSouth's SONET equipment provides this functionality. This requirement applies to line switched rings only.
- 10.3.1.13 Provide 50 millisecond restoration unless a ring protection delay is set to accommodate dual ring interworking schemes.
- 10.3.1.14 Have settable ring protection switching thresholds that shall be set in accordance with Interprise America's specifications.
- 10.3.1.15 Provide revertive protection switching with a settable wait to restore delay with a default setting of 5 minutes. This requirement applies to line switched rings only.
- 10.3.1.16 Provide non-revertive protection switching. This requirement applies to path switched rings only.
- 10.3.1.17 Adhere to the following availability requirements, where availability is defined in the technical reference set forth in Section 10.4.5 of this Attachment.

- 10.3.1.17.1 For any circuit through the ring, no more than 3.5 minutes of unavailability per month.
- 10.3.1.17.2 For any circuit through the ring, no more than 10 minutes of unavailability per year.
- 10.4 At a minimum, Dedicated Transport shall meet each of the requirements set forth in Section 9.2.4 of this Attachment and in the following technical references:
 - 10.4.1 ANSI T1.105.04-1995, American National Standard for Telecommunications - Synchronous Optical Network (SONET) - Data Communication Channel Protocols and Architectures;
 - 10.4.2 ANSI T1.119-1994, American National Standard for Telecommunications - Synchronous Optical Network (SONET) - Operations, Administration, Maintenance, and Provisioning (OAM&P) Communications;
 - 10.4.3 ANSI T1.119.01-1995, American National Standard for Telecommunications - Synchronous Optical Network (SONET) - Operations, Administration, Maintenance, and Provisioning (OAM&P) Communications Protection Switching Fragment;
 - 10.4.4 ANSI T1.119.02-199x, American National Standard for Telecommunications - Synchronous Optical Network (SONET) - Operations, Administration, Maintenance, and Provisioning (OAM&P) Communications Performance Monitoring Fragment;
 - 10.4.5 ANSI T1.231-1993 -American National Standard for Telecommunications - Digital Hierarchy - Layer 1 In-Service Digital Transmission performance monitoring.
 - 10.4.6 AT&T Technical Reference TR 54016, Requirements For Interfacing Digital Terminal Equipment To Services Employing The Extended Superframe Format, September 1989, where the underlying equipment used by BellSouth to provide unbundled dedicated transport supports this functionality;
 - 10.4.7 **DELETED**
 - 10.4.7.1 ANSI T1.101-1994, American National Standard for Telecommunications - Synchronization Interface Standard Performance and Availability;
 - 10.4.7.2 ANSI T1.102-1993, American National Standard for Telecommunications - Digital Hierarchy - Electrical Interfaces;

- 10.4.7.3 ANSI T1.102.01-199x, American National Standard for Telecommunications - Digital Hierarchy - VT1.5;
- 10.4.7.4 ANSI T1.105-1995, American National Standard for Telecommunications - Synchronous Optical Network (SONET) - Basic Description including Multiplex Structure, Rates and Formats;
- 10.4.7.5 ANSI T1.105.01-1995, American National Standard for Telecommunications - Synchronous Optical Network (SONET) - Automatic Protection Switching;
- 10.4.7.6 ANSI T1.105.02-1995, American National Standard for Telecommunications - Synchronous Optical Network (SONET) - Payload Mappings;
- 10.4.7.7 ANSI T1.105.03-1994, American National Standard for Telecommunications - Synchronous Optical Network (SONET) - Jitter at Network Interfaces;
- 10.4.7.8 ANSI T1.105.03a-1995, American National Standard for Telecommunications - Synchronous Optical Network (SONET): Jitter at Network Interfaces - DS1 Supplement;
- 10.4.7.9 ANSI T1.105.05-1994, American National Standard for Telecommunications - Synchronous Optical Network (SONET) - Tandem Connection;
- 10.4.7.10 ANSI T1.105.06-199x, American National Standard for Telecommunications - Synchronous Optical Network (SONET) - Physical Layer Specifications;
- 10.4.7.11 ANSI T1.105.07-199x, American National Standard for Telecommunications - Synchronous Optical Network (SONET) - Sub STS-1 Interface Rates and Formats;
- 10.4.7.12 ANSI T1.105.09-199x, American National Standard for Telecommunications - Synchronous Optical Network (SONET) - Network Element Timing and Synchronization;
- 10.4.7.13 ANSI T1.106-1988, American National Standard for Telecommunications - Digital Hierarchy - Optical Interface Specifications (Single Mode);
- 10.4.7.14 ANSI T1.107-1988, American National Standard for Telecommunications - Digital Hierarchy - Formats Specifications;

- 10.4.7.15 ANSI T1.107a-1990 - American National Standard for Telecommunications - Digital Hierarchy - Supplement to Formats Specifications (DS3 Format Applications);
- 10.4.7.16 ANSI T1.107b-1991 - American National Standard for Telecommunications - Digital Hierarchy - Supplement to Formats Specifications;
- 10.4.7.17 ANSI T1.117-1991, American National Standard for Telecommunications - Digital Hierarchy - Optical Interface Specifications (SONET) (Single Mode - Short Reach);
- 10.4.7.18 ANSI T1.403-1989, Carrier to Customer Installation, DS1 Metallic Interface Specification;
- 10.4.7.19 ANSI T1.404-1994, Network-to-Customer Installation - DS3 Metallic Interface Specification;
- 10.4.7.20 ITU Recommendation G.707, Network node interface for the synchronous digital hierarchy (SDH);
- 10.4.7.21 ITU Recommendation G.704, Synchronous frame structures used at 1544, 6312, 2048, 8488 and 44736 kbit/s hierarchical levels;
- 10.4.7.22 Bellcore FR-440 and TR-NWT-000499, Transport Systems Generic Requirements (TSGR): Common Requirements;
- 10.4.7.23 Bellcore GR-820-CORE, Generic Transmission Surveillance: DS1 & DS3 Performance;
- 10.4.7.24 Bellcore GR-253-CORE, Synchronous Optical Network Systems (SONET); Common Generic Criteria;
- 10.4.7.25 Bellcore TR-NWT 000507, Transmission, Section 7, Issue 5 (Bellcore, December 1993). (A module of LSSGR, FR-NWT-000064.);
- 10.4.7.26 Bellcore TR-NWT-000776, Network Interface Description for ISDN Customer Access;
- 10.4.7.27 Bellcore TR-INS-000342, High-Capacity Digital Special Access Service-Transmission Parameter Limits and Interface Combinations, Issue 1 February 1991;
- 10.4.7.28 Bellcore ST-TEC 000052, Telecommunications Transmission Engineering Textbook, Volume 2: Facilities, Third Edition, Issue I May 1989;

- 10.4.7.29 Bellcore ST-TEC-000051, Telecommunications Transmission Engineering Textbook Volume 1: Principles, Third Edition. Issue 1 August 1987;
- 10.5 **Digital Cross-Connect System (DCS)**
- 10.5.1 **Definition**
- 10.5.1.1 DCS provides automated cross connection of Digital Signal level 0 (DS0) or higher transmission bit rate digital channels within physical interface facilities. Types of DCSs include but are not limited to DCS 1/0s, DCS 3/1s, and DCS 3/3s, where the nomenclature 1/0 denotes interfaces typically at the DS1 rate or greater with cross-connection typically at the DS0 rate. This same nomenclature, at the appropriate rate substitution, extends to the other types of DCSs specifically cited as 3/1 and 3/3. Types of DCSs that cross-connect Synchronous Transport Signal level 1 (STS-1s) or other Synchronous Optical Network (SONET) signals (*e.g.*, STS-3) are also DCSs, although not denoted by this same type of nomenclature. DCS may provide the functionality of more than one of the aforementioned DCS types (*e.g.*, DCS 3/3/1 which combines functionality of DCS 3/3 and DCS 3/1). For such DCSs, the requirements will be, at least, the aggregation of requirements on the “component” DCSs.
- 10.5.1.2 In locations where automated cross connection capability does not exist, DCS will be defined as the combination of the functionality provided by a Digital Signal Cross-Connect (DSX) or Light Guide Cross-Connect (LGX) patch panels and D4 channel banks or other DS0 and above multiplexing equipment used to provide the function of a manual cross connection.
- 10.5.1.3 Interconnection between a DSX or LGX, to a switch, another cross-connect, or other service platform device, is included as part of DCS.
- 10.6 **DCS Technical Requirements**
- 10.6.1 DCS shall provide completed end-to-end cross connection of the channels designated by Interprise America.
- 10.6.2 DCS shall perform facility grooming, multipoint bridging, one-way broadcast, two-way broadcast. Upon request by Interprise America pursuant to the Bona Fide Request Process, BellSouth will provide Interprise America with access to integrated test functionality on the DCS subject to vendor development that will allow sharing of such functionality among multiple users and that will include necessary security features.

- 10.6.3 Where technically available in BellSouth's DCS system and supported by BellSouth's network management software, DCS shall provide multiplexing, format conversion, signaling conversion, or other functions.
- 10.6.4 The end-to-end cross connection assignment shall be input to the underlying device used to provide DCS from an operator at a terminal or via an intermediate system. The cross connection assignment shall remain in effect whether or not the circuit is in use.
- 10.6.5 BellSouth shall continue to administer and maintain DCS, including updates to the control software to current available releases.
- 10.6.6 BellSouth shall provide various types of Digital Cross-Connect Systems including:
 - 10.6.6.1 DS0 cross-connects (typically termed DCS 1/0);
 - 10.6.6.2 DS1/VT1.5 (Virtual Tributaries at the 1.5Mbps rate) cross-connects (typically termed DCS 3/1);
 - 10.6.6.3 DS3 cross-connects (typically termed DCS 3/3);
 - 10.6.6.4 STS-1 cross-connects; and
 - 10.6.6.5 Other technically feasible cross-connects designated by Interprise America.
- 10.6.7 BellSouth shall provide an automated interface which will allow Interprise America to, in real time, control the configuration and reconfiguration of channels on the DCS. Interprise America's method of accessing the automated DCS configuration and reconfiguration is via special access private line.
- 10.6.8 DCS shall continuously monitor protected circuit packs and redundant common equipment.
- 10.6.9 Where technically available in BellSouth's DCS System, DCS shall automatically switch to a protection circuit pack on detection of a failure or degradation of normal operation.
- 10.6.10 The underlying equipment used to provide DCS shall be equipped with a redundant power supply or a battery back-up.
- 10.6.11 BellSouth shall make available to Interprise America spare facilities and equipment necessary for provisioning repairs, as it does for itself and for its own customers.

- 10.6.12 Effective as of the date this unbundled network element is offered, BellSouth will perform network management functions twenty-four (24) hours a day seven (7) days a week via electronic interfaces between Interprise America and BellSouth network management centers. At Interprise America's option, BellSouth shall provide Interprise America with real time performance monitoring and alarm data on the signals and the components of the underlying equipment used to provide DCS that actually impact Interprise America's services.
- 10.6.13 Upon request by Interprise America pursuant to Bona Fide Request Process, BellSouth shall provide Interprise America with real time ability to initiate tests on integrated equipment used to test the signals and the underlying equipment used to provide DCS, as well as other integrated functionality for routine testing and fault isolation. Until such real time ability is available, BellSouth will perform such testing if requested by Interprise America.
- 10.6.14 Where technically available in BellSouth's DCS System and supported by BellSouth's network management software, DCS shall provide SONET to asynchronous gateway functionality (e.g., STS-1 to DS1 or STS-1 to DS3).
- 10.6.15 Where technically available in BellSouth's DCS System and supported by BellSouth's network management software, DCS shall perform optical to electrical conversion where the underlying equipment used to provide DCS contains optical interfaces or terminations (e.g., Optical Carrier level 3, i.e., OC-3, interfaces on a DCS 3/1).
- 10.6.16 Where technically available in BellSouth's DCS System and supported by BellSouth's network management software, DCS shall have SONET ring terminal functionality where the underlying equipment used to provide DCS acts as a terminal on a SONET ring.
- 10.6.17 Where technically available in BellSouth's DCS System and supported by BellSouth's network management software, DCS shall provide multipoint bridging of multiple channels to other DCSs. Interprise America may designate multipoint bridging to be one-way broadcast from a single master to multiple tributaries, or two-way broadcast between a single master and multiple tributaries.
- 10.6.18 Where technically available in BellSouth's DCS System and supported by BellSouth's network management software, DCS shall multiplex lower speed channels onto a higher speed interface and demultiplex higher speed channels onto lower speed interfaces as designated by Interprise America.

- 10.6.19 Where technically available in BellSouth's DCS System and supported by BellSouth's network management software, DCS shall perform signaling conversion and data conditioning as designated by Interprise America.
- 10.7 **DCS Interface Requirements**
- 10.7.1 Where technically available in BellSouth's DCS System and supported by BellSouth's network management software, BellSouth shall provide physical interfaces on DS0, DS1, and VT1.5 channel cross-connect devices at the DS1 rate or higher. In all such cases, these interfaces shall be in compliance with applicable Bellcore, ANSI, and ITU standards.,
- 10.7.2 Where technically available in BellSouth's DCS System and supported by BellSouth's network management software, BellSouth shall provide physical interfaces on DS3 channel cross-connect devices at the DS3 rate or higher. In all such cases, these interfaces shall be in compliance with applicable Bellcore, ANSI and ITU standards.
- 10.7.3 Where technically available in BellSouth's DCS System and supported by BellSouth's network management software, BellSouth shall provide physical interfaces on STS-1 cross-connect devices at the OC-3 rate or higher. In all such cases, these interfaces shall be in compliance with applicable Bellcore, ANSI and , ITU standards.
- 10.7.4 Where technically available in BellSouth's DCS System and supported by BellSouth's network management software, Interfaces on all other cross-connect devices shall be in compliance with applicable Bellcore, ANSI and , ITU , standards.
- 10.8 DCS shall, at a minimum, meet all the requirements set forth in the following technical references:
- 10.8.1 **DELETED**
- 10.8.2 ANSI T1.102-1993, American National Standard for Telecommunications - Digital Hierarchy - Electrical Interfaces;
- 10.8.3 ANSI T1.102.01-199x, American National Standard for Telecommunications - Digital Hierarchy - VT1.5;
- 10.8.4 ANSI T1.105-1995, American National Standard for Telecommunications - Synchronous Optical Network (SONET) - Basic Description including Multiplex Structure, Rates and Formats;

- 10.8.5 ANSI T1.105.03-1994, American National Standard for Telecommunications - Synchronous Optical Network (SONET) - Jitter at Network Interfaces;
- 10.8.6 ANSI T1.105.03a-1995, American National Standard for Telecommunications - Synchronous Optical Network (SONET): Jitter at Network Interfaces - DS1 Supplement;
- 10.8.7 ANSI T1.105.06-199x, American National Standard for Telecommunications - Synchronous Optical Network (SONET) - Physical Layer Specifications;
- 10.8.8 ANSI T1.106-1988, American National Standard for Telecommunications - Digital Hierarchy - Optical Interface Specifications (Single Mode);
- 10.8.9 ANSI T1.107-1988, American National Standard for Telecommunications - Digital Hierarchy - Formats Specifications;
- 10.8.10 ANSI T1.107a-1990 - American National Standard for Telecommunications - Digital Hierarchy - Supplement to Formats Specifications (DS3 Format Applications);
- 10.8.11 ANSI T1.107b-1991 - American National Standard for Telecommunications - Digital Hierarchy - Supplement to Formats Specifications;
- 10.8.12 ANSI T1.117-1991, American National Standard for Telecommunications - Digital Hierarchy - Optical Interface Specifications (SONET) (Single Mode - Short Reach);
- 10.8.13 ANSI T1.403-1989, Carrier to Customer Installation, DS1 Metallic Interface Specification;
- 10.8.14 ANSI T1.404-1994, Network-to-Customer Installation - DS3 Metallic Interface Specification;
- 10.8.15 ITU Recommendation G.707, Network node interface for the synchronous digital hierarchy (SDH);
- 10.8.16 ITU Recommendation G.704, Synchronous frame structures used at 1544, 6312, 2048, 8488 and 44736 kbit/s hierarchical levels;
- 10.8.17 BellCore FR-440 and TR-NWT-000499, Transport Systems Generic Requirements (TSGR): Common Requirements;
- 10.8.18 BellCore GR-820-CORE, Generic Transmission Surveillance: DS1 & DS3 Performance;

10.8.19 BellCore GR-253-CORE, Synchronous Optical Network Systems (SONET); Common Generic Criteria; and

10.8.20 BellCore TR-NWT-000776, Network Interface Description for ISDN Customer Access.

11. **Signaling Link Transport**

11.1 **Definition**

Signaling Link Transport is a set of two or four dedicated 56 Kbps. transmission paths between Interprise America-designated Signaling Points of Interconnection (SPOI) that provides appropriate physical diversity.

11.2 **Technical Requirements**

11.2.1 Signaling Link Transport shall consist of full duplex mode 56 kbps transmission paths.

11.2.2 Of the various options available, Signaling Link Transport shall perform in the following two ways:

11.2.2.1 As an "A-link" which is a connection between a switch or SCP and a home Signaling Transfer Point Switch (STPS) pair; and

11.2.2.2 As a "D-link" which is a connection between two STPS pairs in different company networks (e.g., between two STPS pairs for two Competitive Local Exchange Carriers (CLECs)).

11.2.3 Signaling Link Transport shall consist of two or more signaling link layers as follows:

11.2.3.1 An A-link layer shall consist of two links.

11.2.3.2 A D-link layer shall consist of four links.

11.2.4 A signaling link layer shall satisfy a performance objective such that:

11.2.4.1 There shall be no more than two minutes down time per year for an A-link layer; and

11.2.4.2 There shall be negligible (less than 2 seconds) down time per year for a D-link layer.

11.2.5 A signaling link layer shall satisfy interoffice and intraoffice diversity of facilities and equipment, such that:

11.2.5.1 No single failure of facilities or equipment causes the failure of both links in an A-link layer (i.e., the links should be provided on a minimum of two separate physical paths end-to-end); and

11.2.5.2 No two concurrent failures of facilities or equipment shall cause the failure of all four links in a D-link layer (i.e., the links should be provided on a minimum of three separate physical paths end-to-end).

11.3 **Interface Requirements**

11.3.1 There shall be a DS1 (1.544 Mbps) interface at the Interprise America-designated SPOIs. Each 56 kbps transmission path shall appear as a DS0 channel within the DS1 interface.

12. **Signaling Transfer Points (STPs)**

12.1 **Definition** - Signaling Transfer Points is a signaling network function that includes all of the capabilities provided by the signaling transfer point switches (STPSs) and their associated signaling links which enable the exchange of SS7 messages among and between switching elements, database elements and signaling transfer point switches. Figure 4 depicts Signaling Transfer Points.

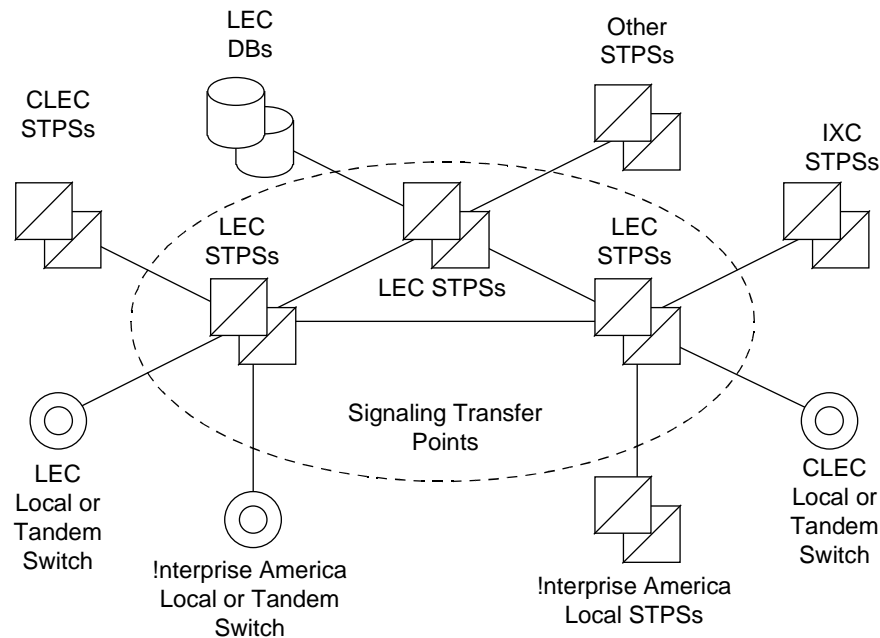

Figure 4

12.2 **Technical Requirements**

- 12.2.1 STPs shall provide access to Network Elements connected to BellSouth SS7 network. These include:
 - 12.2.1.1 BellSouth Local Switching or Tandem Switching;
 - 12.2.1.2 BellSouth Service Control Points/DataBases;
 - 12.2.1.3 Third-party local or tandem switching
 - 12.2.1.4 Third-party-provided STPs.
- 12.2.2 The connectivity provided by STPs shall fully support the functions of all other Network Elements connected to BellSouth SS7 network. This explicitly includes the use of BellSouth SS7 network to convey messages which neither originate nor terminate at a signaling end point directly connected to BellSouth SS7 network (*i.e.*, transient messages). When BellSouth SS7 network is used to convey transient messages, there shall be no alteration of the Integrated Services Digital Network User Part (ISDNUP) or Transaction Capabilities Application Part (TCAP) user data that constitutes the content of the message.
- 12.2.3 If a BellSouth tandem switch routes calling traffic, based on dialed or translated digits, on SS7 trunks between a !nterprise America local switch and third party local switch, BellSouth SS7 network shall convey the TCAP messages that are necessary to provide Call Management features (Automatic Callback, Automatic Recall, and Screening List Editing) between the !nterprise America local STPs and the STPs that provide connectivity with the third party local switch, even if the third party local switch is not directly connected to BellSouth STPs.
- 12.2.4 STPs shall provide all functions of the MTP as defined in Bellcore ANSI Interconnection Requirements. This includes:
 - 12.2.4.1 Signaling Data Link functions, as defined in Bellcore ANSI Interconnection Requirements,
 - 12.2.4.2 Signaling Link functions, as defined in Bellcore ANSI Interconnection Requirements, and
 - 12.2.4.3 Signaling Network Management functions, as defined in Bellcore ANSI Interconnection Requirements.
- 12.2.5 STPs shall provide all functions of the SCCP necessary for Class 0 (basic connectionless) service, as defined in Bellcore ANSI Interconnection Requirements. In particular, this includes Global Title Translation (GTT) and SCCP Management procedures, as specified in T1.112.4. In cases where the destination signaling point is a BellSouth local or tandem switching system or data base, or is a !nterprise America

or third party local or tandem switching system directly connected to BellSouth SS7 network, STPs shall perform final GTT of messages to the destination and SCCP Subsystem Management of the destination. In all other cases, STPs shall perform intermediate GTT of messages to a gateway pair of STPs in an SS7 network connected with BellSouth SS7 network, and shall not perform SCCP Subsystem Management of the destination.

- 12.2.6 STPs shall also provide the capability to route SCCP messages based on ISNI, as defined in Bellcore ANSI Interconnection Requirements, when this capability becomes available on BellSouth STPs.
- 12.2.7 STPs shall provide on a non-discriminatory basis all functions of the OMAP commonly provided by STPs, as specified in the reference in Section 10.4.5 of this Attachment. All OMAP functions will be on a "where available" basis and can include:
 - 12.2.7.1 MTP Routing Verification Test (MRVT) and
 - 12.2.7.2 SCCP Routing Verification Test (SRVT).
- 12.2.8 In cases where the destination signaling point is a BellSouth local or tandem switching system or database, or is a Interprise America or third party local or tandem switching system directly connected to the BellSouth SS7 network, STPs shall perform MRVT and SRVT to the destination signaling point. In all other cases, STPs shall perform MRVT and SRVT to a gateway pair of STPs in an SS7 network connected with the BellSouth SS7 network. This requirement shall be superseded by the specifications for Internetwork MRVT and SRVT if and when these become approved ANSI standards and available capabilities of BellSouth STPs, and if mutually agreed upon by Interprise America and BellSouth.
- 12.2.9 STPs shall be equal to or better than the following performance requirements:
 - 12.2.9.1 MTP Performance, as defined in Bellcore ANSI Interconnection Requirements and
 - 12.2.9.2 SCCP Performance, as defined in Bellcore ANSI Interconnection Requirements.
- 12.2.10 **SS7 Advanced Intelligent Network (AIN) Access**
 - 12.2.10.1 SS7 AIN Access shall provide the Interprise America SCP access to BellSouth local switch via interconnection of BellSouth SS7 and Interprise America SS7 Networks. BellSouth shall offer SS7 access

through its STPs. BellSouth may utilize a mediation device on any part of its networks, as necessary.

12.2.10.1.1 DELETED

SS7 AIN Access is the provisioning of AIN triggers in a BellSouth local switch and interconnection of the BellSouth SS7 network with the Interprise America SS7 network to exchange TCAP queries and responses with an Interprise America SCP. See Figure 5 below.

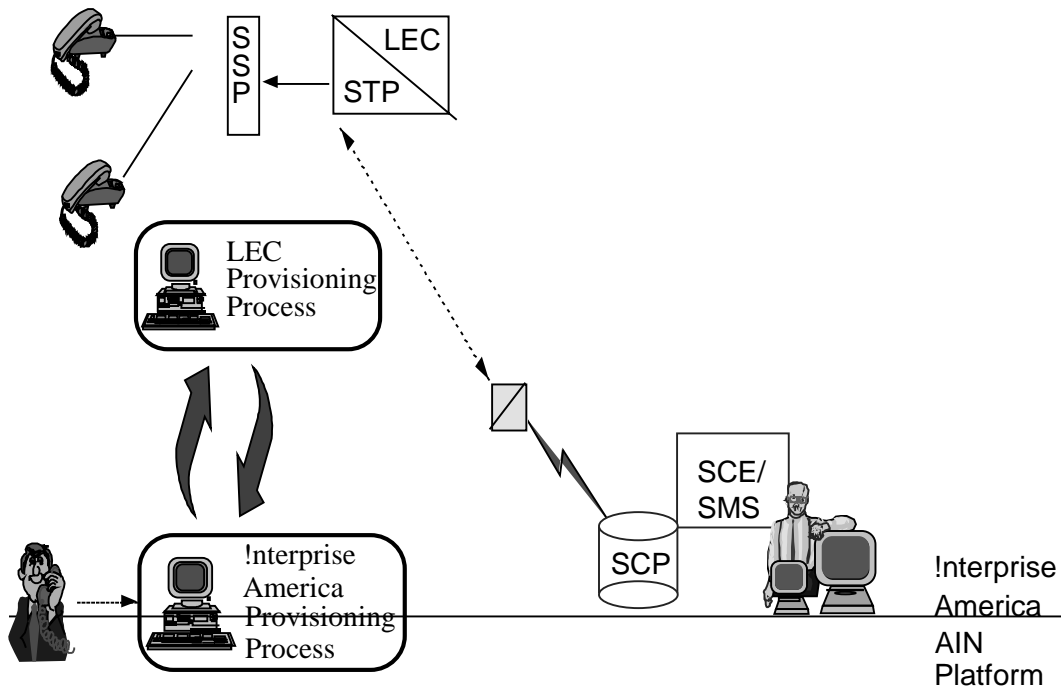

Figure 5

- 12.2.10.2 Physical interconnection between the BellSouth SS7 and the Interprise America SS7 networks shall be through facilities and protocols as specified in the SS7 Network Interconnection section of this Agreement.
- 12.2.10.3 Reliability of interconnection shall be consistent with requirements for diversity and survivability as specified in the SS7 Network Interconnection section of this Agreement.
- 12.2.10.4 When provided through the same mediation application, delay associated with BellSouth local switch queries to the Interprise America STP shall be equal to or shorter than the delay associated with queries to BellSouth STP.

- 12.2.10.5 BellSouth's STP's shall maintain global title translations necessary to direct AIN queries for select global title address and translation type values to the Interprise America SS7 network.
- 12.2.10.6 BellSouth STPs shall route mutually agreeable AIN responses from the Interprise America SCP via SS7 network interconnect to the local switch designated in the Signaling Connection Control Part (SCCP) called party address.
- 12.2.10.7 Network management controls resulting from an overload in elements not supporting Interprise America customers shall not affect queries to Interprise America SCPs.
- 12.2.10.8 Requirements for billing and recording information to track AIN query-response usage shall be consistent with Connectivity Billing and Recording requirements as specified in Attachment 6 (*e.g.*, recorded message format and content, timeliness of feed, data format and transmission medium).
- 12.2.10.9 BellSouth shall provide to Interprise America all necessary testing resources and staff to perform SS7 certification testing prior to interconnection in accordance with the Cooperative Testing section of this Agreement.
- 12.2.10.10 When Interprise America selects SS7 AIN Access, BellSouth will provide access to provisioning processes to support interconnection of Interprise America's STPs.
- 12.2.10.11 When Interprise America selects SS7 AIN Access, BellSouth will provide interconnection of its SS7 network with BellSouth SS7 network for exchange of AIN TCAP messages as described in Section 12.2.10.13.2 below.
- 12.2.10.12 STPs shall offer SS7 AIN Access in accordance with the requirements of the following technical references, as implemented in BellSouth's STPs:
- 12.2.10.12.1 BellCore GR-2863-CORE, CCS Network Interface Specification Supporting Advanced Intelligent Network (AIN); and
- 12.2.10.12.2 BellCore GR-2902-CORE, CCS Network Interface Specification (CCSNIS) Supporting Toll-Free Service Using Advanced Intelligent Network (AIN).

12.3 **Interface Requirements**

- 12.3.1 BellSouth shall provide the following STPs options to connect Interprise America or Interprise America-designated local switching systems or STPs to BellSouth SS7 network:

- 12.3.1.1 An A-link interface from Interprise America local switching systems; and,
- 12.3.1.2 A D-link interface from Interprise America local STPSs.
- 12.3.2 Each type of interface shall be provided by one or more sets (layers) of signaling links, as follows:
 - 12.3.2.1 An A-link layer shall consist of two links, as depicted in Figure 6.

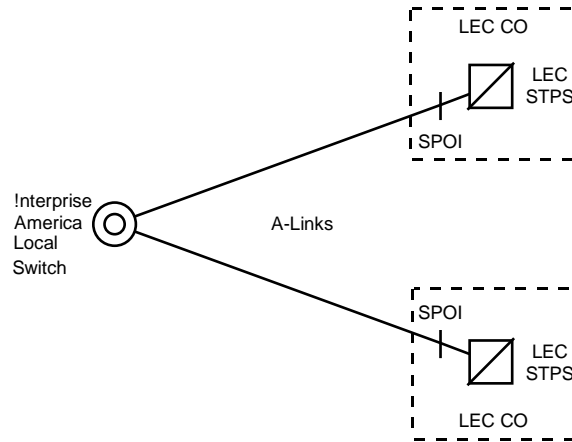

Figure 6. A-Link Interface

- 12.3.2.2 A D-link layer shall consist of four links, as depicted in Figure 7.

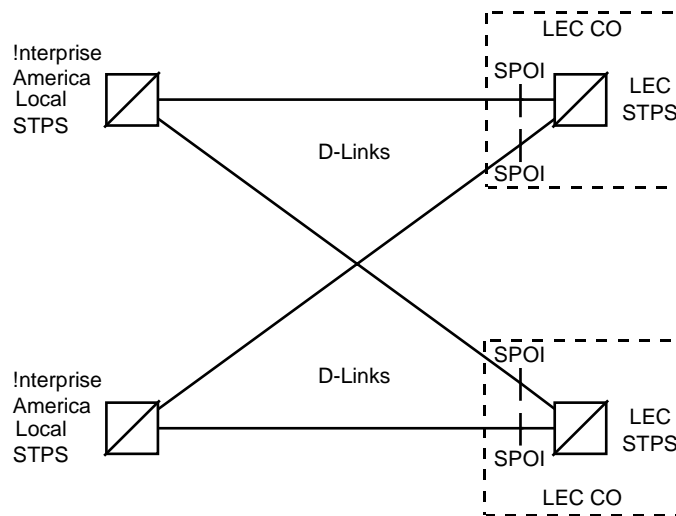

Figure 7. D-Link Interface

- 12.3.3 The Signaling Point of Interconnection (SPOI) for each link shall be located at a cross-connect element, such as a DSX-1, in the Central Office (CO) where BellSouth STPS is located. There shall be a DS1 or higher rate transport interface at each of the SPOIs. Each signaling link

shall appear as a DS0 channel within the DS1 or higher rate interface. BellSouth shall offer higher rate DS1 signaling for interconnecting Interprise America local switching systems or STPSs with BellSouth STPSs as soon as these become approved ANSI standards and available capabilities of BellSouth STPSs. BellSouth and Interprise America will work jointly to establish mutually acceptable SPOIs.

- 12.3.4 BellSouth CO shall provide intraoffice diversity between the SPOIs and BellSouth STPS, so that no single failure of intraoffice facilities or equipment shall cause the failure of both D-links in a layer connecting to a BellSouth STPS. BellSouth and Interprise America will work jointly to establish mutually acceptable SPOIs.
- 12.3.5 BellSouth shall provide MTP and SCCP protocol interfaces that shall conform to all sections relevant to the MTP or SCCP in the following specifications:
 - 12.3.5.1 Bellcore GR-905-CORE, Common Channel Signaling Network Interface Specification (CCSNIS) Supporting Network Interconnection, Message Transfer Part (MTP), and Integrated Services Digital Network User Part (ISDNUP);
 - 12.3.5.2 Bellcore GR-1432-CORE, CCS Network Interface Specification (CCSNIS) Supporting Signaling Connection Control Part (SCCP) and Transaction Capabilities Application Part (TCAP).
- 12.3.6 **Message Screening**
 - 12.3.6.1 BellSouth shall set message screening parameters so as to accept valid messages from Interprise America local or tandem switching systems destined to any signaling point within BellSouth's SS7 network where the Interprise America switching system has a legitimate signaling relation.
 - 12.3.6.2 BellSouth shall set message screening parameters so as to pass valid messages from Interprise America local or tandem switching systems destined to any signaling point or network accessed through BellSouth's SS7 network where the Interprise America switching system has a legitimate signaling relation.
 - 12.3.6.3 BellSouth shall set message screening parameters so as to accept and pass/send valid messages destined to and from Interprise America from any signaling point or network interconnected through BellSouth's SS7 network where the Interprise America SCP has a legitimate signaling relation.
- 12.4 STPs shall be equal to or better than all of the requirements for STPs set forth in the following technical references:

- 12.4.1 ANSI T1.111-1992 American National Standard for Telecommunications - Signaling System Number 7 (SS7) - Message Transfer Part (MTP);
- 12.4.2 ANSI T1.111A-1994 American National Standard for Telecommunications - Signaling System Number 7 (SS7) - Message Transfer Part (MTP) Supplement;
- 12.4.3 ANSI T1.112-1992 American National Standard for Telecommunications - Signaling System Number 7 (SS7) - Signaling Connection Control Part (SCCP);
- 12.4.4 ANSI T1.115-1990 American National Standard for Telecommunications - Signaling System Number 7 (SS7) - Monitoring and Measurements for Networks;
- 12.4.5 ANSI T1.116-1990 American National Standard for Telecommunications - Signaling System Number 7 (SS7) - Operations, Maintenance and Administration Part (OMAP);
- 12.4.6 ANSI T1.118-1992 American National Standard for Telecommunications - Signaling System Number 7 (SS7) - Intermediate Signaling Network Identification (ISNI);
- 12.4.7 Bellcore GR-905-CORE, Common Channel Signaling Network Interface Specification (CCSNIS) Supporting Network Interconnection, Message Transfer Part (MTP), and Integrated Services Digital Network User Part (ISDNUP); and
- 12.4.8 Bellcore GR-1432-CORE, CCS Network Interface Specification (CCSNIS) Supporting Signaling Connection Control Part (SCCP) and Transaction Capabilities Application Part (TCAP).

13. **Service Control Points/DataBases**

13.1 **Definition**

13.1.1 Databases are the Network Elements that provide the functionality for storage of, access to, and manipulation of information required to offer a particular service and/or capability. Databases include, but are not limited to: Local Number Portability, LIDB, Toll Free Number Database, Automatic Location Identification/Data Management System, access to Service Creation Environment and Service Management System (SCE/SMS) application databases and Directory Assistance.

13.1.2 A Service Control Point (SCP) is a specific type of Database functionality deployed in a Signaling System 7 (SS7) network that executes service application logic in response to SS7 queries sent to it by a switching

system also connected to the SS7 network. Service Management Systems provide operational interfaces to allow for provisioning, administration and maintenance of subscriber data and service application data stored in SCPs.

13.2 **Technical Requirements for SCPs/Databases**

Requirements for SCPs/Databases within this section address storage of information, access to information (e.g. signaling protocols, response times), and administration of information (e.g., provisioning, administration, and maintenance). All SCPs/Databases shall be provided to Interprise America in accordance with the following requirements, except where such a requirement is superseded by specific requirements set forth in Subsections 13.3 through 13.7 of this Attachment:

13.2.1 BellSouth shall provide physical interconnection to SCPs through the SS7 network and protocols, as specified in Section 10 of this Attachment, with TCAP as the application layer protocol.

13.2.2 BellSouth shall provide physical interconnection to databases via industry standard interfaces and protocols (e.g. ISDN and X.25).

13.2.3 The reliability of interconnection options shall be consistent with requirements for diversity and survivability as specified in Section 10 of this Attachment (which applies to both SS7 and non-SS7 interfaces).

13.2.4 **Database Availability**

Call processing databases shall have a maximum unscheduled availability of 30 minutes per year. Unavailability due to software and hardware upgrades shall be scheduled during minimal usage periods and only be undertaken upon proper notification to providers which might be impacted. Any downtime associated with the provision of call processing related databases will impact all service providers, including BellSouth, equally.

13.2.5 BellSouth shall provide Database provisioning consistent with the provisioning requirements of this Agreement (e.g., data required, edits, acknowledgments, data format and transmission medium and notification of order completion).

13.2.6 The operational interface provided by BellSouth shall complete Database transactions (i.e., add, modify, delete) for Interprise America customer records stored in BellSouth databases within 24 hours, or sooner where BellSouth provisions its own customer records within a shorter interval.

- 13.2.7 BellSouth shall provide Database maintenance consistent with the maintenance requirements as specified in this Agreement (e.g., notification of BellSouth Network Affecting Events, testing, dispatch schedule and measurement and exception reports).
- 13.2.8 BellSouth shall provide billing and recording information to track database usage consistent with connectivity billing and recording requirements as specified in this Agreement (e.g., recorded message format and content, timeliness of feed, data format and transmission medium).
- 13.2.9 BellSouth shall provide SCPs/Databases in accordance with the physical security requirements specified in this Agreement.
- 13.2.10 BellSouth shall provide SCPs/Databases in accordance with the logical security requirements specified in this Agreement.

13.3 **Local Number Portability Database**

13.3.1 **Definition**

The Permanent Number Portability (PNP) database supplies routing numbers for calls involving numbers that have been ported from one local service provider to another. PNP is currently being worked in industry forums. The results of these forums will dictate the industry direction of PNP. BellSouth agrees to provide the PNP database as directed by the FCC.

13.3.2 **DELETED**

13.3.3 **DELETED**

13.4 **Line Information Database (LIDB):**

This Subsection 13.4 defines and sets forth additional requirements for the Line Information Database. This Subsection 13.4 supplements the requirements of Subsection 13.2 and 13.8 of this Attachment. Interprise America acknowledges that BellSouth will store in its LIDB only records relating to service in the BellSouth region.

13.4.1 **Definition**

The Line Information Database (LIDB) is a transaction-oriented database accessible through Common Channel Signaling (CCS) networks. It contains records associated with customer Line Numbers and Special Billing Numbers (in accordance with the requirements in the technical reference in Section 13.8.5 of this Attachment). LIDB accepts queries from other Network Elements and provides appropriate responses. The query originator need not be the owner of LIDB data. LIDB queries

include functions such as screening billed numbers that provides the ability to accept Collect or Third Number Billing calls and validation of Telephone Line Number based non-proprietary calling cards. The interface for the LIDB functionality is the interface between BellSouth CCS network and other CCS networks. LIDB also interfaces to administrative systems. The administrative system interface provides Interprise America Work Centers with an interface to LIDB for functions such as provisioning, auditing of data, access to LIDB measurements and reports.

13.4.2 Technical Requirements:

Interprise America LIDB technical requirements are set forth below. BellSouth also will offer to Interprise America any additional capabilities that are developed for LIDB during the life of this Agreement.

- 13.4.2.1 Prior to the availability of a long-term solution for Local Number Portability, BellSouth shall enable Interprise America to store in BellSouth's LIDB any customer Line Number or Special Billing Number record, (in accordance with the technical reference in Section 13.8.5 of this Attachment) whether ported or not, for which the non-Interprise America dedicated NPA-NXX or RAO-0/1XX Group is supported by that LIDB, except for numbers ported from a third party local services provider.
- 13.4.2.2 Prior to the availability of a long-term solution for Local Number Portability, BellSouth shall enable Interprise America to store in BellSouth's LIDB any customer Line Number or Special Billing Number (in accordance with the technical reference in Section 13.8.5) record, whether ported or not, and Interprise America dedicated NPA-NXX or RAO-0/1XX Group Records, except for numbers ported from a third party local services provider.
- 13.4.2.3 Subsequent to the availability of a long-term solution for Local Number Portability, BellSouth shall enable Interprise America to store in BellSouth's LIDB any customer Line Number or Special Billing Number (in accordance with the technical reference in Section 13.8.5) record, whether ported or not, regardless of the number's dedicated NPA-NXX or RAO[NXX]-0/1XX., except for numbers ported from a third party local services provider.
- 13.4.2.4 BellSouth shall perform the following LIDB functions (i.e., processing of the following query types as defined in the technical reference in Section 13.8.5 of this Attachment) for Interprise America's customer records in LIDB:
- 13.4.2.4.1 Billed Number Screening (provides information such as whether the Billed Number may accept Collect or Third Number Billing calls); and

- 13.4.2.4.2 Calling Card Validation: If Interprise America chooses to offer Tel Line Number TLN and/or Special Billing Number (SBN credit cards, calling card validation will be supported for the Interprise America customer data in the LIDB.
- 13.4.2.5 BellSouth shall process Interprise America's Customer records in LIDB at least at parity with BellSouth customer records, with respect to other LIDB functions (as defined in the technical reference in Section 13.8.5 of this Attachment). BellSouth shall indicate to Interprise America what additional functions (if any) are performed by LIDB in the BellSouth network.
- 13.4.2.6 Within two (2) weeks after a request by Interprise America, BellSouth shall provide Interprise America with a list of the customer data items which Interprise America would have to provide in order to support each required LIDB function. The list shall indicate which data items are essential to LIDB function, and which are required only to support certain services. For each data item, the list shall show the data formats, the acceptable values of the data item and the meaning of those values.
- 13.4.2.7 BellSouth shall provide LIDB systems for which operating deficiencies that would result in calls being blocked, shall not exceed 30 minutes per year.
- 13.4.2.8 BellSouth shall provide LIDB systems for which operating deficiencies that would not result in calls being blocked shall not exceed 12 hours per year.
- 13.4.2.9 BellSouth shall provide LIDB systems for which the LIDB function shall be in overload (degraded performance in accordance with the technical reference in Section 13.8.5 of this Attachment) no more than 12 hours per year. Such deficiency period is in addition to the periods specified in Sections 13.4.2.7 and 13.4.2.8 above.
- 13.4.2.10 BellSouth shall provide Interprise America with the capability to provision (e.g., to add, update, and delete) NPA-NXX and RAO-0/1XX Group Records, and Line Number and Special Billing Number Records, associated with Interprise America customers, directly into the BellSouth's LIDB provisioning process. The capability to provision (e.g., to add, update, and delete) NPA-NXX and RAO-01/1XX Group records, and Line Number and Special Billing Number Records, associated with Interprise America customers will be provided by BellSouth's DBAC. Direct access into BellSouth's LIDB process is not currently available. Once Direct access becomes available with the appropriate security measures, BellSouth will offer such access to Interprise America. In the interim, BellSouth will provide access by electronic mail, facsimile or password-protected phone call (applicable to Group level NPA-NXX and

RAO-01/1XX, updated within the same day if notification to BellSouth is received by 1:00 PM central time).

- 13.4.2.11 BellSouth shall maintain customer data (for line numbers, card numbers, and for any other types of data maintained in LIDB) so that such customers shall not experience any interruption of service due to the lack of such maintenance of customer data. In the event that end user customers change their local services provider, BellSouth will use its best efforts to minimize service interruption in those situations where BellSouth has control over additions and deletions to the database as the LIDB provider.
- 13.4.2.12 All additions, updates and deletions of Interprise America data to the LIDB shall be solely at the direction of Interprise America. Such direction from Interprise America will not be required where the addition, update or deletion is necessary to perform standard fraud control measures (e.g., calling card auto-deactivation).
- 13.4.2.13 BellSouth shall provide priority updates to LIDB for Interprise America data upon Interprise America's request (e.g., to support fraud detection), via password-protected telephone card, facsimile, or electronic mail within one hour of notice from the established BellSouth contact.
- 13.4.2.14 BellSouth shall provide Interprise America with the capability to directly obtain, through an electronic interface, reports of all Interprise America data in LIDB. Such capability will be through the data migration format (FCIF Interface) that can be used to electronically obtain reports of Interprise America data in LIDB.
- 13.4.2.15 BellSouth shall provide LIDB systems such that no more than 0.01% of Interprise America customer records will be missing from LIDB, as measured by Interprise America audits. BellSouth will audit Interprise America records in LIDB against DBAS to identify record mis-matches and provide this data to a designated Interprise America contact person to resolve the status of the records and BellSouth will update system appropriately. BellSouth will refer record of mis-matches to Interprise America within one business day of audit. Once reconciled records are received back from Interprise America, BellSouth will update LIDB the same business day if less than 500 records are received before 1:00PM Central Time. If more than 500 records are received, BellSouth will contact Interprise America to negotiate a time frame for the updates, not to exceed three business days.
- 13.4.2.16 BellSouth shall perform backup and recovery of all of Interprise America's data in LIDB including sending to LIDB all changes made since the date of the most recent backup copy, in at least the same time frame BellSouth performs backup and recovery of BellSouth data in

LIDB for itself. Currently, BellSouth performs backups of the LIDB for itself on a weekly basis and when a new software release is scheduled, a backup is performed prior to loading the new release.

13.4.2.17 BellSouth shall provide to Interprise America access to LIDB measurements and reports at least at parity with the capability that BellSouth has for its own customer records and that BellSouth provides to any other party. Electronic access shall be offered to Interprise America when it becomes available. Currently, BellSouth provides the following information from the Billing Measurements System summarized by Data Owner/Query Originator:

- Calling Card Queries
- Billed Number Screening Queries
- Calling Card Successful
- Calling Card Denied
- Calling Card CCAN Service Denied
- Calling Card Pin Match Field
- Calling Card Record Not Found
- Billed Number Screening Successful
- Billed Number Screening Not Found
- Group Not Found
- BNS/C Processing Indicator Not Enabled
- Group Status/Nonparticipating

As additional LIDB measurements and reports become available, such measurements and reports also will be provided to Interprise America.

13.4.2.18 BellSouth shall provide Interprise America with LIDB reports of data which are missing or contain errors, as well as any misroute errors, within a reason time period as negotiated between Interprise America and BellSouth.

13.4.2.19 BellSouth shall prevent any access to or use of Interprise America data in LIDB by BellSouth personnel that are outside of established administrative and fraud control personnel, or by any other party that is not authorized by Interprise America in writing.

13.4.2.20 BellSouth shall provide Interprise America performance of the LIDB Data Screening function, which allows a LIDB to completely or partially deny specific query originators access to LIDB data owned by specific data owners, (in accordance with the technical reference in Section 13.8.5 of this Attachment) for Customer Data that is part of an NPA-NXX or RAO-0/1XX wholly or partially owned by Interprise America at least at parity with BellSouth Customer Data. BellSouth shall obtain from Interprise America the screening information associated with LIDB Data Screening of Interprise America data in accordance with this requirement. BellSouth currently does not have LIDB Data Screening capabilities.

When such capability is available, BellSouth shall offer it to Interprise America under the Bona Fide Request process identified in Section 1.1 of this Agreement.

- 13.4.2.21 BellSouth shall accept queries to LIDB associated with Interprise America customer records, and shall return responses in accordance with the requirements of Section 13.8.5.
- 13.4.2.22 BellSouth shall provide mean processing time at the LIDB within 0.50 seconds under normal conditions as defined in the technical reference in Section 13.8.5 of this Attachment.
- 13.4.2.23 BellSouth shall provide processing time at the LIDB within 1 second for 99% of all messages under normal conditions as defined in the technical reference in Section 13.8.5 of this Attachment.
- 13.4.2.24 BellSouth shall provide 99.9 % of all LIDB queries in a round trip within 2 seconds as defined in the technical reference in Section 13.8.5.
- 13.4.2.25 BellSouth shall provide data in LIDB replies with no more than 2% unexpected data values. Per BellCORE document SR334, because the majority of the error (i.e., fraud attempts, customer or operator misdialing, and CPE malfunctions) are beyond the LIDB owner, Unexpected Data Value - PIN Mismatch should not be considered measurement of BellSouth LIDB quality. However, should this value exceed 2%, Interprise America and BellSouth will jointly agree if and when root cause analysis is necessary.

13.4.3 **Interface Requirements**

BellSouth shall offer LIDB in accordance with the requirements of this subsection 13.4.3.

- 13.4.3.1 The interface to LIDB shall be in accordance with the technical reference in Section 13.8.3 of this Attachment.
- 13.4.3.2 The CCS interface to LIDB shall be the standard interface described in Section 13.8.3 of this Attachment.
- 13.4.3.3 The LIDB Data Base interpretation of the ANSI-TCAP messages shall comply with the technical reference in Section 13.8.4 of this Attachment. Global Title Translation shall be maintained in the signaling network in order to support signaling network routing to the LIDB.

13.5 **Toll Free Number Database**

The Toll Free Number Database is a SCP that provides functionality necessary for toll free (e.g., 800 and 888) number services by providing routing information and additional so-called vertical features during call

set-up in response to queries from SSPs. This Subsection 13.5 supplements the requirements of Subsections 13.2 and 31.8 of this Agreement. BellSouth shall provide the Toll Free Number Database in accordance with the following:

13.5.1 **Technical Requirements**

13.5.1.1 BellSouth shall make BellSouth Toll Free Number Database available for Interprise America to query with a toll-free number and originating information.

13.5.1.2 The Toll Free Number Database shall return carrier identification and, where applicable, the queried toll free number, translated numbers and instructions as it would in response to a query from a BellSouth switch.

13.5.1.3 The SCP shall also provide, at Interprise America's option, such additional feature as described in SR-TSV-002275 (BOC Notes on BellSouth Networks, SR-TSV-002275, Issue 2, (Bellcore, April 1994)) as are available to BellSouth. These may include but are not limited to:

13.5.1.3.1 Network Management;

13.5.1.3.2 Customer Sample Collection; and

13.5.1.3.3 Service Maintenance

13.5.2 **Interface Requirements**

The signaling interface between the Interprise America or other local switch and the Toll-Free Number database shall use the TCAP protocol as specified in the technical reference in Section 13.8.1 of this Attachment, together with the signaling network interface as specified in the technical reference in Sections 13.8.2 and 13.8.6 of this Agreement.

13.6 **Automatic Location Identification/Data Management System (ALI/DMS)**

The ALI/DMS Database contains customer information (including name, address, telephone information, and sometimes special information from the local service provider or customer) used to determine to which Public Safety Answering Point (PSAP) to route the call. The ALI/DMS database is used to provide more routing flexibility for E911 calls than Basic 911. This Subsection 13.6 supplements the requirements of Subsections 13.8.2 and 13.8.6 of this Attachment. BellSouth shall provide the Emergency Services Database in accordance with the following:

13.6.1 **Technical Requirements**

- 13.6.1.1 BellSouth shall offer Interprise America a data link to the ALI/DMS database or permit Interprise America to provide its own data link to the ALI/DMS database. BellSouth shall provide error reports from the ALI/DMS data base to Interprise America immediately after Interprise America inputs information into the ALI/DMS data base. Alternately, Interprise America may utilize BellSouth, to enter customer information into the data base on a demand basis, and validate customer information on a demand basis.
- 13.6.1.2 The ALI/DMS database shall contain the following customer information:
- 13.6.1.2.1 Name;
- 13.6.1.2.2 Address;
- 13.6.1.2.3 Telephone number; and
- 13.6.1.2.4 Other information as appropriate (e.g., whether a customer is blind or deaf or has another disability).
- 13.6.1.3 When the BellSouth is responsible for administering the ALI/DMS database in its entirety, ported number NXXs entries for the ported numbers should be maintained unless Interprise America requests otherwise and shall be updated if Interprise America requests, provided Interprise America supplies BellSouth with the updates.
- 13.6.1.4 When Remote Call Forwarding (RCF) is used to provide number portability to the local customer and a remark or other appropriate field information is available in the database, the shadow or "forwarded-to" number and an indication that the number is ported shall be added to the customer record.
- 13.6.1.5 If BellSouth is responsible for configuring PSAP features (for cases when the PSAP or BellSouth supports an ISDN interface) it shall ensure that CLASS Automatic Recall (Call Return) is not used to call back to the ported number. Although BellSouth currently does not have ISDN interface, BellSouth agrees to comply with this requirement once ISDN interfaces are in place.
- 13.6.2 **Interface Requirements**
- The interface between the E911 Switch or Tandem and the ALI/DMS database for Interprise America customers shall meet industry standards.
- 13.7 **Directory Assistance Database**
- BellSouth shall make its directory assistance database available to Interprise America in order to allow Interprise America to provide its

customers with the same directory assistance services BellSouth provides to BellSouth customers. BellSouth shall provide Interprise America with an initial feed via magnetic tape and daily update initially via magnetic tape and subsequently via an electronic gateway to be developed mutually by Interprise America and BellSouth of customer address and number changes. Directory Assistance Services must provide both the ported and CLEC telephone numbers to the extent available in BellSouth's database assigned to a customer. Privacy indicators must be properly identified to assure the non-published numbers are accurately identified.

- 13.8 SCPs/Databases shall be equal to or better than all of the requirements for SCPs/Databases set forth in the following technical references:
- 13.8.1 BellCore GR-246-CORE, Bell Communications Research Specification of Signaling System Number 7, ISSUE 1 (Bellcore, December 1999);
- 13.8.2 BellCore GR-1432-CORE, CCS Network Interface Specification (CCSNIS) Supporting Signaling Connection Control Part (SCCP) and Transaction Capabilities Application Part (TCAP). (Bellcore, March 1994);
- 13.8.3 BellCore GR-954-CORE, CCS Network Interface Specification (CCSNIS) Supporting Line Information Database (LIDB) Service 6, Issue 1, Rev. 1 (Bellcore, October 1995);
- 13.8.4 BellCore GR-1149-CORE, OSSGR Section 10: System Interfaces, Issue 1 (Bellcore, October 1995) (Replaces TR-NWT-001149);
- 13.8.5 BellCore GR-1158-CORE, OSSGR Section 22.3: Line Information Database 6, Issue (Bellcore, October 1995);
- 13.8.6 BellCore GR-1428-CORE, CCS Network Interface Specification (CCSNIS) Supporting Toll Free Service (Bellcore, May 1995); and
- 13.8.7 BOC Notes on BellSouth Networks, SR-TSV-002275, ISSUE 2, (Bellcore, April 1994).
- 13.9 Service Creation Environment and Service Management System (SCE/SMS) Advanced Intelligent Network (AIN) Access
- 13.9.1 BellSouth's Service Creation Environment and Service Management System (SCE/SMS) Advanced Intelligent Network (AIN) Access shall provide Interprise America the capability that will allow Interprise America and other third parties to create service applications in a BellSouth Service Creation Environment and deploy those applications in a BellSouth SMS to a BellSouth SCP. The third party service

applications interact with AIN triggers provisioned on a BellSouth SSP. See Figure 8 below.

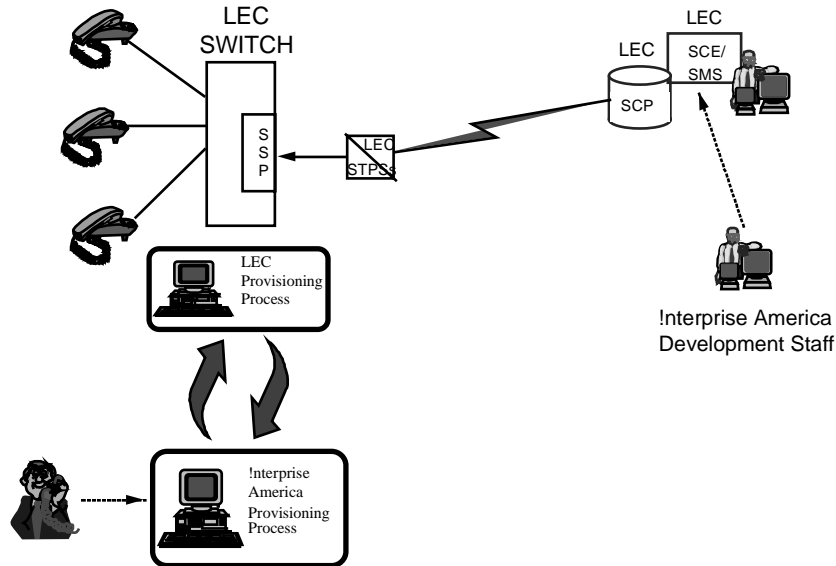

Figure 8

- 13.9.2 BellSouth's SCE/SMS AIN Access shall provide access to SCE hardware, software, testing and technical support (e.g., help desk, system administrator) resources available to Interprise America. Scheduling procedures shall provide Interprise America equivalent priority to these resources
- 13.9.3 BellSouth's SCE/SMS AIN Access shall allow for multi-user access with proper source code management and other logical security functions as specified in the Security section of this Agreement.
- 13.9.4 BellSouth SCP shall partition and protect Interprise America service logic and data from unauthorized access, execution or other types of compromise.
- 13.9.5 When Interprise America selects SCE/SMS AIN Access, BellSouth shall provide training, documentation, and technical support to enable Interprise America to use BellSouth's SCE/SMS AIN Access to create and administer applications. Training, documentation, and technical support will address use of SCE and SMS access and administrative functions, but will not include support for the creation of a specific service application.
- 13.9.6 When Interprise America selects SCE/SMS AIN Access, BellSouth shall provide for a secure, controlled access environment in association with

its internal use of AIN components. Interprise America access will be provided via remote data connection (e.g., dial-in, ISDN).

13.9.7 When Interprise America selects SCE/SMS AIN Access, BellSouth shall allow Interprise America to download data forms and/or tables to BellSouth SCP via BellSouth SMS without intervention from BellSouth (e.g., service customization and customer subscription).

13.9.8 **DELETED**

14. **Tandem Switching**

14.1 **Definition**

Tandem Switching is the function that establishes a communications path between two switching offices through a third switching office (the tandem switch).

14.2 **Technical Requirements**

14.2.1 Tandem Switching shall have the same capabilities or equivalent capabilities as those described in Bell Communications Research TR-TSY-000540 Issue 2R2, Tandem Supplement, 6/1/90. The requirements for Tandem Switching include, but are not limited to the following:

14.2.1.1 Tandem Switching shall provide signaling to establish a tandem connection;

14.2.1.2 Tandem Switching will provide screening as jointly agreed to by Interprise America and BellSouth;

14.2.1.3 **DELETED**

14.2.1.4 Tandem Switching shall provide Advanced Intelligent Network triggers supporting AIN features where such routing is not available from the originating end office switch, to the extent such Tandem switch has such capability

14.2.1.5 **DELETED**

14.2.1.6 Tandem Switching shall provide access to Toll Free number portability database as designated by Interprise America;

14.2.1.7 Tandem Switching shall provide all trunk interconnections discussed under the "Network Interconnection" section (e.g., SS7, MF, DTMF, DialPulse, PRI-ISDN, DID, and CAMA-ANI (if appropriate for 911));

- 14.2.1.8 Tandem Switching shall provide connectivity to PSAPs where 911 solutions are deployed and the tandem is used for 911; and
- 14.2.1.9 Tandem Switching shall provide connectivity to transit traffic to and from other carriers.
- 14.2.2 Tandem Switching shall accept connections (including the necessary signaling and trunking interconnections) between end offices, other tandems, IECs, ICOs, CAPs and CLEC switches.
- 14.2.3 Tandem Switching shall provide local tandeming functionality between two end offices including two offices belonging to different CLEC's (e.g., between an Interprise America end office and the end office of another CLEC).
- 14.2.4 Tandem Switching shall preserve CLASS/LASS features and Caller ID as traffic is processed. Additional signaling information and requirements are provided in Section 10 of this Attachment.
- 14.2.5 Tandem Switching shall record billable events and send them to the area billing centers designated by Interprise America. Tandem Switching will provide recording of all billable events as jointly agreed to by Interprise America and BellSouth.
- 14.2.6 Upon a reasonable request from Interprise America, BellSouth shall perform routine testing and fault isolation on the underlying switch that is providing Tandem Switching and all its interconnections. The results and reports of the testing shall be made immediately available to Interprise America.
- 14.2.7 BellSouth shall maintain Interprise America's trunks and interconnections associated with Tandem Switching at least at parity to its own trunks and interconnections.
- 14.2.8 **DELETED**
- 14.2.9 BellSouth shall control congestion points and network abnormalities. All traffic will be restricted in a non discriminatory manner.
- 14.2.10 Tandem Switching shall route calls to BellSouth or Interprise America endpoints or platforms (e.g., operator services and PSAPs) on a per call basis as designated by Interprise America, where such routing is not available from the originating end office switch, to the extent such Tandem Switch has such capability. Detailed primary and overflow routing plans for all interfaces available within BellSouth switching network shall be mutually agreed to by Interprise America and BellSouth. Such plans shall meet Interprise America requirements for routing calls through the local network.

- 14.2.11 Tandem Switching shall process originating toll-free traffic received from a Interprise America local switch.
- 14.2.12 In support of AIN triggers and features, Tandem Switching shall provide SSP capabilities when these capabilities are not available from the Local Switching Network Element, to the extent such Tandem Switch has such capability.
- 14.2.13 **DELETED**
- 14.3 **Interface Requirements**
- 14.3.1 Tandem Switching shall provide interconnection to the E911 PSAP where the underlying Tandem is acting as the E911 Tandem.
- 14.3.2 Tandem Switching shall interconnect, with direct trunks, to all carriers with which BellSouth interconnects.
- 14.3.3 BellSouth shall provide all signaling necessary to provide Tandem Switching with no loss of feature functionality.
- 14.3.4 Tandem Switching shall interconnect with Interprise America's switch, using two-way trunks, for traffic that is transiting via BellSouth network to interLATA or intraLATA carriers. At Interprise America's request, Tandem Switching shall record and keep records of traffic for billing.
- 14.3.5 Tandem Switching shall provide an alternate final routing pattern for Interprise America traffic overflowing from direct end office high usage trunk groups.
- 14.3.6 **DELETED**
- 14.4 Tandem Switching shall meet or exceed (i.e., be more favorable to Interprise America) each of the requirements for Tandem Switching set forth in the following technical references:
 - 14.4.1 Bell Communications Research TR-TSY-000540 Issue 2R2, Tandem Supplement, 6/1/90;
 - 14.4.2 BellCore GR-905-CORE covering CCSNIS;
 - 14.4.3 BellCore GR-1429-CORE for call management features; and BellCore GR-2863-CORE and BellCore GR-2902-CORE covering CCS AIN interconnection

15. **DARK FIBER**

Definition

- 15.1.1 Dark Fiber is unused strands of optical fiber. Dark Fiber also includes stands of optical fiber existing in aerial or underground structure which have lightwave repeater (regenerator or optical amplifier) equipment interspliced to at appropriate distances, but which has no line terminating elements terminated to such strands to operationalize its transmission capabilities.
- 15.2 **Requirements**
- 15.2.1 BellSouth shall make available Dark Fiber where it exists in BellSouth's network and where, as a result of future building or deployment, it becomes available. Interprise America agrees not to propose dark fiber for future unspecified uses. BellSouth may not refuse to make dark fiber available without a legitimate business purpose. If refusing a request by Interprise America, BellSouth should show that it will need the dark fiber within three years. Interprise America may petition the Kentucky Public Service Commission if it can demonstrate BellSouth is unwilling to cooperate in the provision of dark fiber. BellSouth shall offer all Dark Fiber to Interprise America pursuant to the prices set forth in Part IV of this Agreement.
- 15.2.2 BellSouth shall provide a Single Point of Contact (SPOC) for negotiating all Dark Fiber arrangements.
- 15.2.3 Interprise America may test the quality of the Dark Fiber to confirm its usability and performance specifications.
- 15.2.4 BellSouth shall use its best efforts to provide to Interprise America information regarding the location, availability and performance of Dark Fiber within ten (10) business days for a records based answer and twenty (20) business days for a field based answer, after receiving a request from Interprise America ("Request"). Within such time period, BellSouth shall send written confirmation of availability of the Dark Fiber ("Confirmation"). From the time of the Request to (90) days after Confirmation, BellSouth shall hold such requested Dark Fiber for Interprise America's use and may not allow any other party to use such media, including BellSouth.
- 15.2.5 BellSouth shall use its best efforts to make Dark Fiber available to Interprise America within thirty (30) business days after it receives written confirmation from Interprise America that the Dark Fiber previously deemed available by BellSouth is wanted for use by Interprise America. This includes identification of appropriate connection points (e.g., Light Guide Interconnection (LGX) or splice points) to enable Interprise America to connect or splice Interprise America provided transmission media (e.g., optical fiber) or equipment to the Dark Fiber.

- 15.3 Additional Requirements for Dark Fiber
- 15.3.1 Dark fiber service shall be provided on fiber cables which meet the following requirements: single mode fibers, with a degradation of 0.40 dB/km at 1210 nm and 0.25 dB/km at 1550 nm.
- 15.3.2 Interprise America may splice and test Dark Fiber obtained from BellSouth using Interprise America or Interprise America designated personnel. BellSouth shall provide appropriate interfaces to allow splicing and testing of Dark Fiber. BellSouth shall provide an excess cable length of 25 feet minimum (for fiber in underground conduit) to allow the uncoiled fiber to reach from the manhole to a splicing van.

16. **Additional Requirements**

This Section 16 of Attachment 2 sets forth the additional requirements for unbundled Network Elements which BellSouth agrees to offer to Interprise America under this Agreement.

16.1 **Cooperative Testing**

16.1.1 **Definition**

Cooperative Testing means that BellSouth shall cooperate with Interprise America upon request or as needed to (1) ensure that the Network Elements and Ancillary Functions and additional requirements being provided to Interprise America by BellSouth are in compliance with the requirements of this Agreement, and (2) test the overall functionality of various Network Elements and Ancillary Functions provided by BellSouth to Interprise America in combination with each other or in combination with other equipment and facilities provided by Interprise America or third parties, and (3) ensure that all operational interfaces and processes are in place and functioning properly and efficiently for the provisioning and maintenance of Network Elements and Ancillary Functions and so that all appropriate billing data can be provided to Interprise America.

16.1.2 **Requirements**

BellSouth shall provide performance equal to or better than all of the requirements set forth in this Section 16.1.2. In addition, within ninety (90) days of the Effective Date of this Agreement, Interprise America and BellSouth will agree upon a Cooperative Testing process which will include procedures for resolving technical issues relating to interconnection of Interprise America's network to BellSouth's network and Network Elements and Ancillary Functions. The agreed upon process shall include procedures for escalating disputes and unresolved

issues up through higher levels of each company's management. If Interprise America and BellSouth do not reach agreement on such a process within ninety (90) days, any issues that have not been resolved by the parties with respect to such process shall be handled pursuant to the procedures identified in Section 15 of the General Terms and Conditions of this Agreement unless both parties agree to extend the time to reach agreement on such issues. The cooperative testing process shall address the following:

- 16.1.2.1 Interprise America access for testing at any interface between a BellSouth Network Element or combinations and Interprise America equipment or facilities. Such test access must be sufficient to ensure that the applicable requirements can be tested by Interprise America seven (7) days per week, 24 hours per day.
- 16.1.2.2 Testing of any interfaces, Network Elements or Ancillary Functions and additional requirements provided by BellSouth pursuant to this Agreement.
- 16.1.2.3 Engineering data for the loop components as set forth in this Attachment which Interprise America may desire to test. Such data shall include equipment engineering and cable specifications, signaling and transmission path data.
- 16.1.2.4 Interprise America requests for office records, central office layout and design records and drawings, system engineering and other applicable documentation pertaining to a Network Element or Ancillary Function or the underlying equipment that is then providing a Network Element or Ancillary Function to Interprise America.
- 16.1.2.5 Interprise America requests for any applicable test results, from BellSouth testing activities on a Network Element or Ancillary Function or Additional Requirement or the underlying equipment providing a Network Element or Ancillary Function or Additional Requirements to Interprise America. Interprise America may review such testing results and may notify BellSouth of any deficiencies that are detected.
- 16.1.2.6 Interprise America request for the temporary provision of selected Local Switching features for testing.
- 16.1.2.7 Technical staff to meet with Interprise America representatives to provide required support for Cooperative Testing.
- 16.1.2.8 Dedicated Transport and Loop Feeder may experience alarm conditions due to in-progress tests. BellSouth shall not remove such facilities from service without obtaining Interprise America's prior approval.

- 16.1.2.9 Tests or maintenance procedures on Network Elements or Ancillary Functions or on the underlying equipment that is then providing a Network Element or Ancillary Function, that may cause a service interruption or degradation if such tests and procedures are at a time that is mutually acceptable to !nterprise America and BellSouth.
- 16.1.2.10 A single point of contact to !nterprise America that is available 7 days per week, 24 hours per day for trouble status, sectionalization, resolution, escalation, and closure. Such staff shall be adequately skilled to allow expeditious problem resolution.
- 16.1.2.11 Electronic access to 105 responders, 100-type test lines, or 102-type test lines associated with any circuits under test.
- 16.1.2.12 BellSouth participation in Cooperative Testing with !nterprise America upon !nterprise America's request to test any operational interface or process used to provide Network Elements, Ancillary Functions or Services to !nterprise America.
- 16.1.2.13 Completing Cooperative Testing expeditiously.
- 16.1.2.14 Enhancements to BellSouth's provisioning processes to deliver Network Elements and Ancillary Functions and any Additional Requirements to !nterprise America in shorter intervals than during subsequent normal service periods.
- 16.1.2.15 BellSouth participation in Cooperative Testing requested by !nterprise America whenever it is deemed necessary by !nterprise America to insure service performance, reliability and customer serviceability.
- 16.1.2.16 Procedures to cover !nterprise America acceptance or rejection of a Network Element ordered by !nterprise America if upon completion of cooperative acceptance testing, the tested Network Element does not meet the requirements stated herein.

16.2 **Performance**

16.2.1 **Scope:**

This section addresses performance requirements for Network Elements and Ancillary Functions to provide local service. It includes requirements for the reliability and availability of Network Elements and Ancillary Functions, and quality parameters such as transmission quality (analog and digital), and speed (or delay). In addition, an overview of service performance requirements is given.

- 16.2.1.1 The General Performance Requirements in this section apply to all aspects of Network Elements and Ancillary Functions. Additional

requirements are given in this performance section and in the individual Network Elements sections.

- 16.2.2 BellSouth shall work cooperatively with Interprise America to determine appropriate performance allocations across Network Elements.
- 16.2.3 BellSouth shall comply with the following technical documents to the extent that they are consistent with the greater of BellSouth's actual performance or applicable industry standards. If Interprise America requests performance that exceeds either the industry standards or the actual performance that BellSouth provides to itself, then Interprise America shall request such additional requirements through the Bona Fide Request process set forth in Section 1.1 of the General Terms and Conditions of this Agreement.
 - 16.2.3.1 **Bell Communications Research, Inc. Documents**
 - 16.2.3.1.1 FR-64, *LATA Switching Systems Generic Requirements (LSSGR)*. This document contains 117 Technical References and Generic Requirements. Sections provide the requirements for local switching systems (also referred to as end offices) that serve customers' lines. Some modules of the LSSGR are also referenced separately in this document.
 - 16.2.3.1.2 TR-NWT-000499, Issue 5, Rev 1, April 1992, *Transport Systems Generic Requirements (TSGR): Common Requirements*.
 - 16.2.3.1.3 TR-NWT-000418, Issue 2, December 1992, *Generic Reliability Assurance Requirements For Fiber Optic Transport Systems*.
 - 16.2.3.1.4 TR-NWT-000057, Issue 2, January 1993, *Functional Criteria for Digital Loop Carriers Systems*.
 - 16.2.3.1.5 TR-NWT-000507, Issue 5, December 1993, *LSSGR - Transmission, Section 7*.
 - 16.2.3.1.6 GR-303-CORE, Issue 1, September 1995, *Integrated Digital Loop Carrier System Generic Requirements, Objectives, and Interface*.
 - 16.2.3.1.7 GR-334-CORE, Issue 1, June 1994, *Switched Access Service: Transmission Parameter Limits and Interface Combinations*.
 - 16.2.3.1.8 TR-NWT-000335, Issue 3, May 1993, *Voice Grade Special Access Services - Transmission Parameter Limits and Interface Combinations*.
 - 16.2.3.1.9 TR-TSY-000529, Issue 2, July 1987, *Public Safety - LSSGR*.

- 16.2.3.1.10 GR-1158-CORE, Issue 2, October 1995, *OSSGR Section 22.3: Line Information Database*.
- 16.2.3.1.11 TR-TSY-000511, Issue 2, July 1987, *Service Standards, a Module (Section 11) of LATA Switching Systems Generic Requirements (LSSGR, FR-NWT-000064)*.
- 16.2.3.1.12 TR-NWT-000393, January 1991, *Generic Requirements for ISDN Basic Access Digital Subscriber Lines*.
- 16.2.3.1.13 TR-NWT-000909, December 1991, *Generic Requirements and Objectives for Fiber In The Loop Systems*.
- 16.2.3.1.14 TR-NWT-000505, Issue 3 , May 1991, *LSSGR Section 5, Call Processing*.
- 16.2.3.1.15 FR-NWT-000271, 1993, *Operator Services Systems Generic Requirements (OSSGR)*.
- 16.2.3.1.16 TR-NWT-001156, Issue 2, July 1993, *OSSGR Operator Services Systems Generic Requirements, Section 21, Operator Subsystem*.
- 16.2.3.1.17 SR-TSY-001171, Issue 1, January 1989, *Methods and Procedures for System Reliability Analysis*.
- 16.2.3.1.18 Bellcore *Telecommunications Transmission Engineering*, 3rd Ed, 1990.

- 16.2.3.2 **ANSI Standards**
- 16.2.3.2.1 ANSI T1.512-1994, Network Performance - Point-to-Point Voice-Grade Special Access Network Voiceband Data Transmission Objectives.
- 16.2.3.2.2 ANSI T1.506-1990, Network Performance - Transmission Specifications for Switched Exchange Access Network.
- 16.2.3.2.3 ANSI T1.508-1992, Telecommunications - Network Performance - Loss Plan for Evolving Digital Networks. Also supplement T1.508a-1993.
- 16.2.3.2.4 ANSI T1.101-1994, Digital Synchronization Network Plan.
- 16.2.3.3 **TIA/EIA Standards**
- 16.2.3.3.1 Requirements not specifically addressed here shall be found in the documents listed in Electronic Industries

Association/Telecommunications Industries Association Standards and Engineering Publications.

- 16.2.3.3.2 TIA/EIA TSB-37A, Telephone Network Transmission Model for Evaluating Modem Performance.
- 16.2.3.3.3 TIA/EIA TSB-38, Test Procedure for Evaluation of 2-wire 4 kHz Voiceband Duplex Modems.
- 16.2.3.4 **IEEE Standards**
- 16.2.3.4.1 IEEE Standard 743-1984, IEEE Standard Methods and Equipment for Measuring Transmission Characteristics of Analog Voice Frequency Circuits.
- 16.2.3.4.2 ANSI/IEEE Standard 820-1984, Telephone Loop Performance Characteristics.
- 16.2.4 **Services and Capabilities**
- 16.2.4.1 All Network Elements shall provide performance sufficient, in combination with other Network Elements, to provide the following applications in accordance with the requirements of this document:
 - 16.2.4.1.1 Voice services.
 - 16.2.4.1.2 Voice-band data modem connections up to 9.6 kbps and up to and including 28.8 kbps V.34 when available.
 - 16.2.4.1.3 FAX transmissions up to and including 14.4 kbps group 3.
 - 16.2.4.1.4 CLASS/LASS features.
 - 16.2.4.1.5 Operator Systems.
- 16.2.4.2 Where available, the following capabilities shall be provided as applicable:
 - 16.2.4.2.1 ISDN BRI
 - 16.2.4.2.2 ISDN PRI
 - 16.2.4.2.3 Switched Digital Data
 - 16.2.4.2.4 Non-Switched Digital Data
 - 16.2.4.2.5 Types of Video applications

16.2.4.2.6 Coin Services

16.2.4.2.7 Frame Relay and ATM

16.2.4.2.8 Private Line Services

16.2.5 Specific Performance Requirements

BellSouth shall comply with the following performance requirements to the extent that they are consistent with the greater of BellSouth's actual performance or applicable industry standards. If Interprise America requests performance requirements that exceed either the industry standards or the actual performance that BellSouth provides to itself, then Interprise America shall request such performance through the Bona Fide Request process set forth in Section 1.1 of the General Terms and Conditions of this Agreement.

16.2.5.1 BellSouth shall provide performance equal to or better than all of the requirements set forth in this Section. Unless noted otherwise, requirements and objectives are given in terms of specific limits. This means that all tests (acceptance and ongoing performance) shall meet the limit(s) to satisfy the requirement.

16.2.5.2 **Performance Allocation** Transmission path impairments may be classified as either analog or digital, and will depend on the nature of the signal transmitted across the Network Element. Analog impairments are introduced on any analog portion of the loop, typically between the NID portion of Loop Distribution and the analog to digital (A/D) conversion, and are usually correlated with the length of the physical plant. Digital impairments are introduced by A/D conversion and by interfaces between digital Network Elements. In addition, noise can be introduced by either analog transmission or the A/D conversion.

16.2.5.3 **Loop Combination Architecture Constraints**

16.2.5.3.1 The following constraints will limit not only the variety of Loop Combination architectures that may be considered, but also the architectures BellSouth may consider to deliver any Ancillary Function or Network Element. These constraints apply to the entire path between the NID portion of Loop Distribution and where the unbundled loop element interfaces with Interprise America. Any exceptions to these restrictions shall be specifically requested or approved by Interprise America in writing.

16.2.5.3.1.1 No more than 1, 2-to-4-wire hybrid.

16.2.5.3.1.2 No voice compression.

16.2.5.3.1.3 No echo cancelers or suppressers.

- 16.2.5.3.1.4 One digital loss pad per PBX.
- 16.2.5.3.1.5 No digital gain.
- 16.2.5.3.1.6 No additional equipment that might significantly increase intermodulation distortion.

16.2.5.4 **Transmission Impairments**

16.2.5.4.1 **Analog Impairments** Analog impairments are those introduced on portions of the end-to-end circuit on which communications signals are transmitted in analog format. These portions of the transmission path would typically be between NID and an A/D conversion, most commonly on the metallic loop. The performance on the analog portion of a circuit is typically inversely proportional to the length of that circuit.

16.2.5.4.1.1 **Loss**

16.2.5.4.1.1.1 Electrical loss is measured using a 1004 Hz 0.0dB one Milliwatt 900 ohm test tone.

16.2.5.4.1.1.2 Off-hook electrical loss for the unbundled loop element shall be no more than 8.0 dB for any line. On-hook electrical loss for the unbundled loop element shall be no more than 13.9 dB above the off-hook electrical loss for any line, per BellCore Technical Reference No. 57.

16.2.5.4.1.2 **Idle Channel Circuit Noise**

16.2.5.4.1.2.1 Idle channel circuit noise (C-message) is added by analog facilities, by the A/D conversion of signals, by digital processing equipment (e.g. echo cancelers, digital loss pads), robbed bit signaling, and errors on digital facilities.

16.2.5.4.1.2.2 Idle channel circuit noise shall be less than or equal to 18 dB_{BrnC}.

16.2.5.4.1.3 **Talker Echo**

16.2.5.4.1.3.1 The primary source of echo is improper impedance-matching at the 2-to-4 wire hybrid in BellSouth network. The impact on customer perception is a function of both echo return loss and delay.

16.2.5.4.1.3.2 Echo Return Loss (ERL) shall be greater than 26dB to a standard termination (900 ohms, 2.16 μ Fd), and greater than 14 dB to a telephone set off-hook. Singing Return Loss (SRL) shall be greater than 21dB to a standard termination, and greater than 11 dB to a telephone set off-hook.

16.2.5.4.1.4 **Listener Echo**

Listener echo is a double reflection of a transmitted signal at two different impedance mismatches in the end-to-end connection. While in extreme cases it can degrade voice transmission performance, listener echo is primarily an issue for voiceband data. The requirements on Talker Echo shall apply to Listener Echo.

16.2.5.4.1.5 Propagation and Processing Delay

16.2.5.4.1.5.1 Propagation delay is the delay involved in transmitting information from one location to another. It is caused by processing delays of equipment in the network and delays associated with traveling across transmission facilities.

16.2.5.4.1.5.2 BellSouth shall cooperate with Interprise America to limit total service propagation and processing delay to levels at parity with that within the BellSouth local network.

16.2.5.4.1.6 Signal-to-Noise Ratio

16.2.5.4.1.6.1 The Signal-to-Noise Ratio (S/N) is a critical parameter in determining voiceband data performance. It is typically measured with a 1004 Hz tone.

16.2.5.4.1.6.2 BellSouth must provide on the Loop Combination a signal-to-noise ratio of at least 37 dB between the NID and the end office.

16.2.5.4.1.7 C-Notched Noise

The requirements for Signal-to-Noise Ratio shall apply to C-Notched Noise.

16.2.5.4.1.8 Attenuation Distortion

16.2.5.4.1.8.1 Attenuation distortion, also known as frequency distortion or gain slope, measures the variations in loss at different frequencies across the voice frequency spectrum (200 Hz - 3400 Hz). It is measured by subtracting the loss at 1004 Hz from the loss at the frequency of interest.

16.2.5.4.1.8.2 Attenuation distortion from the NID to the switch shall be within the range ± 0.5 dB for frequencies between 304 and 3004 Hz; from the switch to NID attenuation distortion shall be within the range ± 0.5 dB for frequencies between 204 Hz and 3004 Hz. In addition, attenuation distortion shall remain within the range +1dB/-3dB for frequencies between 200 Hz and 3500 Hz.

16.2.5.4.1.9 Envelope Delay Distortion

16.2.5.4.1.9.1 Envelope Delay Distortion (EDD) measures the difference in transit time of signals at different frequencies. EDD is measured relative to the transit time of a 1704 Hz. tone, and is given in microseconds. EDD is used as an approximation of the group delay of the channel.

16.2.5.4.1.9.2 EDD shall be: 1704 Hz to 604 Hz -- $\leq 350 \mu\text{sec.}$; 1704 Hz to 2804 Hz -- $\leq 195 \mu\text{sec.}$; 1704 Hz to 204 Hz -- $\leq 580 \mu\text{sec.}$; 1704 Hz to 3404 Hz -- $\leq 400 \mu\text{sec.}$

16.2.5.4.1.10 **Phase Jitter**

16.2.5.4.1.10.1 Phase jitter measures the unwanted angular modulation of a signal. It is caused by noise or the actual modulation of the signal by another unwanted signal. It displaces the zero crossings of a signal. It is measured in terms of peak-to-peak deviations of a 1004 Hz. tone from its nominal zero crossings, and in a particular frequency band (20-300 Hz and either 4-300 Hz or 2-300 Hz). Phase jitter impacts voiceband data performance and can make modems more susceptible to other impairments, including noise.

16.2.5.4.1.10.2 From the NID to the interexchange carrier point of termination, phase jitter shall be $<1.5^\circ$ point-to-point in the 20-300 Hz band, and $<1.8^\circ$ point-to-point in the 4-300 Hz. band.

16.2.5.4.1.11 **Amplitude Jitter**

16.2.5.4.1.11.1 Amplitude jitter is any deviation of the peak value of a 1004 Hz signal from its nominal value. Excessive amounts can impair voiceband data performance. It is primarily caused by noise but can also be caused by phase jitter, gain hits, or single frequency interference.

16.2.5.4.1.11.2 In NID-interexchange carrier point of termination, $\leq 2.5\%$ of amplitude jitter is permitted in the 20-300 Hz band and $\leq 2.9\%$ in the 4-300 Hz band.

16.2.5.4.1.12 **Intermodulation Distortion**

16.2.5.4.1.12.1 Intermodulation distortion (IMD) measures non-linear distortions of a signal. It compares the power of harmonic tones to the power of the transmitted tones. It is measured for both the 2nd and 3rd harmonics of the transmitted tones. IMD is caused by compression or clipping and can impair voiceband data performance.

16.2.5.4.1.12.2 Both 2nd and 3rd order IMD between the NID and end office must be $\geq 52\text{dB}$.

16.2.5.4.1.13 **Impulse Noise**

16.2.5.4.1.13.1 Impulse noise is a sudden and large increase in noise on a channel for a short duration of time. Impulse noise is measured as a count of the number of times a noise threshold is exceeded during a given time period (typically 5 or 15 minutes). It is caused by protection switching, maintenance activities, electromechanical switching systems, digital transmission errors, and line coding mismatches. Impulse noise sounds like clicking noises or static on voice connections. Impulse noise impairs voiceband data performance.

16.2.5.4.1.13.2 The NID to interexchange carrier point of termination portions of connections shall introduce no impulse noise events within 6dB of the received signal power on 93% of all 15 minute connections. In addition, there shall be no more than 1 impulse noise event within 6 dB of the received signal power during any 30-minute period.

16.2.5.4.1.14 **Phase Hits**

16.2.5.4.1.14.1 Phase hits are a sudden change in the phase of a signal lasting at least 4 msec. Phase hits are measured using a threshold which indicates how much the phase of the signal has changed with respect to its nominal phase. Phase hits are caused by protection switching and slips or other synchronization errors. Phase hits can impair voiceband data performance.

16.2.5.4.1.14.2 Between the NID and interexchange carrier point of termination, 99.75% of all 15-minute connections shall have no phase hits exceeding 10°. In addition, there shall be no more than 1 phase hit exceeding 10° in any 30-minute period.

16.2.5.4.1.15 **Gain Hits**

16.2.5.4.1.15.1 Gain hits are sudden changes in the level of a signal that last at least 4 msec. Gain hits are measured against a threshold of typically 2-5 dB relative to the signal's nominal level. Gain hits are usually caused by protection switches and can impair voiceband data performance.

16.2.5.4.1.15.2 Between the NID and the interexchange carrier point of termination, 99.5% of all 15-minute connections shall have no gain hits exceeding 3 dB. In addition, there shall be no more than 1 gain hit exceeding 3 dB in any 30-minute period.

16.2.5.4.1.16 **Dropouts**

16.2.5.4.1.16.1 Dropouts are drops in the level of a signal of 12 dB or more for at least 4 msec. They are caused by protection switching events, radio fading, and conditions causing digital carrier systems to lose frame. Dropouts

are critical for voiceband data performance but, if severe enough, will also affect voice quality.

16.2.5.4.1.16.2 Between the NID and the interexchange carrier point of termination, 99.9% of all 15-minute connections shall have no dropouts and in addition, no connection shall suffer more than 1 dropout in any 60-minute period.

16.2.5.4.1.17 **Frequency Shift**

16.2.5.4.1.17.1 Frequency shift measures any frequency changes that occur when a signal is transmitted across a channel. It is typically measured using a 1004 Hz tone. Frequency shift has very little impact on voice or voiceband data performance; however, round-trip frequency shifts can affect the ability of echo cancelers to remain converged.

16.2.5.4.1.17.2 No more than 0.2 Hz frequency shift shall be on any connection. In addition, 99.5% of all calls shall have frequency shift < 0.1 Hz.

16.2.5.4.1.18 **Crosstalk**

16.2.5.4.1.18.1 Crosstalk is the presence of signals from other telephone connections on a circuit. Crosstalk can be either intelligible, when speech from other connections can be heard and understood, or unintelligible. Crosstalk is caused by inter-channel interference on the transmission system. Crosstalk is difficult to measure: it requires correlating signals on different circuits or using human listeners to identify its presence. Trouble reports may be used to estimate the probability of crosstalk.

16.2.5.4.1.18.2 99% of Loop Combinations shall have probability $\leq 0.1\%$ of experiencing crosstalk exceeding -65 dBm0.

16.2.5.4.1.19 **Clipping**

16.2.5.4.1.19.1 Clipping occurs when part of a transmitted signal is dropped and does not reach the receiving portion on a connection. It can be caused by Digital Speech Interpolation (DSI) equipment used in Digital Circuit Multiplication Systems (DCMS) which increase the amount of traffic that transmission facilities carry, and by echo cancelers or echo suppressers.

16.2.5.4.1.19.2 No clipping incidents shall occur on any call.

16.2.5.4.2 **Digital Impairments**

Digital impairments occur in the signal wherever it is transmitted in digital format. These errors are usually introduced upon conversion of the

signal from analog to digital, as well as at interfaces between digital components. While many digital impairments have little impact on subjective voice quality, they can impact voiceband data performance.

16.2.5.4.2.1 **Signal Correlated Distortion**

16.2.5.4.2.1.1 Signal correlated distortion (SCD) is unwanted noise or distortion introduced into a signal through the conversion of a signal from analog to digital format or through digital processing that changes the transmitted signal. SCD affects performance when a sign is being transmitted. The primary sources of SCD are signal encoders, echo cancelers, digital loss pads, and robbed bit signaling. SCD affects both voice and voiceband data performance.

16.2.5.4.2.1.2 The NID-to-end-office connection shall allow:

16.2.5.4.2.1.2.1 A maximum of 1 A/D conversion, using 64Kbps μ -law ($\mu=255$) PCM;

16.2.5.4.2.1.2.2 No voice compression;

16.2.5.4.2.1.2.3 No echo cancellation; and

16.2.5.4.2.1.2.4 Robbed bit signaling only if SS7 or ISDN are not used.

16.2.5.4.2.2 **Slips**

16.2.5.4.2.2.1 Slips occur when a frame of digital data is either deleted or repeated because of differences in the clocks used to synchronize digital facilities. Slips sound like clicks or pops on voice calls and have major impact on voiceband data performance.

16.2.5.4.2.2.2 The NID-to-interexchange carrier point of termination portion of connections shall have fewer than 0.45 slips every 24 hours on average.

16.2.5.4.2.3 **Digital Timing Jitter and Wander**

16.2.5.4.2.3.1 Digital timing jitter is the unwanted phase modulation of digital signals at rates above 10 Hz. Wander is the unwanted phase modulation of digital signals at rates below 10 Hz. Digital timing jitter is caused by imperfections in the timing recovery process of repeaters and the stuffing synchronization process used by multiplexer/demultiplexers. Wander is caused by slowly varying changes in digital signal phase due to clock frequency offset and drift, changes in propagation delay of terrestrial facilities due to temperature changes and changes in the distance of satellites from the earth. These events have a major impact on voiceband data performance.

16.2.5.4.2.3.2 The maximum digital timing jitter allowed in the 10 Hz to 8 kHz frequency band at any network interface or any terminal equipment in the network is 5 Unit Intervals (UI). The maximum digital timing jitter allowed in the 8 kHz to 40 kHz frequency band is 0.1 UI. The objective for wander is less than 28 UI at any network interface or terminal equipment.

16.2.5.4.2.4 **DS-1 Errored Seconds**

16.2.5.4.2.4.1 An Errored Second (ES) on a DS-1 facility is any second during which at least 1 bit is in error. The impact of an ES on performance depends on the number of errors that occur during a second. Typically, voice performance is not significantly impacted by ES but they can cause errors in voiceband data transmissions.

16.2.5.4.2.4.2 Each BellSouth work shall have less than 20 ESs per 24 hour period.

16.2.5.4.2.5 **DS-1 Severely Errored Seconds**

16.2.5.4.2.5.1 A severely Errored Second (SES) is any second during which a DS-1 has an error rate exceeding 0.001. An SES can be caused by a loss of framing, a slip, or a protection switch. SESs have impacts on both voice and voiceband data performance. For voice, an SES will sound like a burst of noise or static. SESs that occur during a voiceband data transmission cause a significant burst of errors and can cause modems to retrain.

16.2.5.4.2.5.2 The digital portion of each NID to POP connection shall have less than 2 SESs per 24 hour period).

16.2.5.4.2.6 **Short Failure Events**

16.2.5.4.2.6.1 A Short Failure Event (SFE) is a Loss of Frame (LOF) event of less than two minutes' duration. An LOF event is declared when, on detection of a Loss of Signal (LOS) or Out-of-Frame (OOF), a rise-slope-type integration process starts that declares a LOF after 2.5 ± 0.5 sec. of continuous LOS or OOF. If the LOS or OOF is intermittent, the integration process shall decay at a slope of 1/5 the rise slope during the period when the signal is normal. Thus, if the ratio of a LOS or OOF to a normal signal is greater than 1/2, a LOF will be declared. A LOS condition shall be declared when the Network Channel Terminating Equipment has determined that 175 ± 75 successive pulse positions with no pulses of either positive or negative polarity have occurred. An OOF condition shall be declared when either Network equipment or Digital Terminal Equipment detects errors in the framing pattern.

16.2.5.4.2.6.2 There shall be fewer than 1 SFE per month.

16.2.5.5 Service Availability and Reliability

Availability refers to the time period during which the service is up and usable for its intended purpose. Reliability refers to the probability that a task will be completed successfully, given that it is successfully begun. Where available BellSouth shall provide real-time, remote data access to performance monitoring and alarm data on events affecting (or potentially affecting) Interprise America's traffic.

16.2.5.5.1 Blocked Calls

16.2.5.5.1.1 Blocking is the fraction of call origination attempts denied service during a stated measurement period. Blocking occurs because of competition for limited resources within the network.

16.2.5.5.1.2 For intraLATA toll service as well as for local exchange service, the blocking level from originating network interface (NID) to terminating NID shall not exceed 1.5% in any hour, except under conditions of service disruption. For access to or egress from the Interprise America long distance network, the blocking rate shall not exceed 0.5% in any hour, except under conditions of service disruption.

16.2.5.5.2 Blocked Dial Tone

16.2.5.5.2.1 Blocked dial tone occurs when the subscriber does not receive dial tone within the timeframe, measured in seconds of going off-hook, equal to that which BellSouth provides itself or its end-users.

16.2.5.5.2.2 Customers shall not experience more than 0.1% dial tone blocking during average busy season busy hour (ABSBH).

16.2.5.5.3 Downtime

Downtime is the period of time that a system is in a failed state.

16.2.5.5.3.1 The average downtime for all subscriber Loop Combinations shall be less than 49 minutes per year. The maximum downtime for 99% of all subscriber Loop Combinations shall be less than 74 minutes per year.

16.2.5.5.3.2 The average downtime for an end office switch shall be less than 3 minutes per year. The average downtime for individual trunks shall be less than 28 minutes per year. The average downtime for digital trunk groups shall be less than 20 minutes per year. The average downtime for an individual line appearance at the switch shall be less than 28 minutes per year. The average downtime for a Remote Terminal (RT) shall be less than 17 minutes per year. The average downtime for an individual line on a Remote Terminal (RT) shall be less than 13 minutes per year.

- 16.2.5.5.3.3 The mean time to repair (MTTR) of any equipment at an attended site shall be less than 3 hours. The mean time to repair (MTTR) of any equipment at an unattended site shall be less than 4 hours. 95% of all repairs to the network interface (NID) shall be completed within 24 hours.
- 16.2.5.5.3.4 There shall be no downtime due to power failures at the switch.
- 16.2.5.5.3.5 The probability of a stable call being cut off shall be less than 20 cutoffs per one million 1 minute calls.
- 16.2.5.5.3.6 The rate of ineffective machine attempts at the end office shall be less than 0.0005 (5 failures per 10,000 call attempts).
- 16.2.5.5.3.7 BellSouth shall meet all requirements for private line services in BellCore TR-NWT-000335 and ANSI T1.512-1994.
- 16.2.5.5.4 **Dial Tone Delay**
- 16.2.5.5.4.1 Dial-Tone Delay is the time period between a customer off-hook and the receipt of dial tone from an originating end office. Dial-Tone Delay has a significant effect on customer opinion of service quality.
- 16.2.5.5.4.2 The average dial-tone delay shall not exceed 0.6 seconds. At most 0.5% of calls during the average-season busy hour (ASBH) shall experience dial-tone delay greater than 3 seconds. At most 8% of calls during the ten-high-day busy hour (THDBH) shall experience dial-tone delay greater than 3 seconds. At most 10% of calls during the high-day busy hour (HDBH) shall experience dial-tone delay greater than 3 seconds.
- 16.2.5.5.5 **Dial Tone Removal**
- 16.2.5.5.5.1 Dial tone removal is the time between recognition of the first address digit to the removal of dial tone on the line.
- 16.2.5.5.5.2 The maximum dial tone removal interval shall be ≤ 500 milliseconds.
- 16.2.5.5.6 **Post Dial Delay**
- 16.2.5.5.6.1 Post Dial Delay (PDD) is the amount of time a caller must wait after entering or dialing the last digit of a Destination Telephone Number (DTN) before hearing a valid audible network response. The PDD for an end user is measured from the time the caller has pressed or dialed the last digit of a DTN until receipt of an audible network response.
- 16.2.5.5.6.2 The requirements given reflect an end-to-end CCS7 protocol for Interprise America end users. Where a mixture of CCS7 and inband (MF) signaling protocols are employed, an increase in the PDD can be expected.

16.2.5.5.6.2.1 PDD 1 - A - Intra Interprise America LSO

16.2.5.5.6.2.1.1 Intra-LSO calls do not employ external signaling protocols. The PDD for intra-LSO calls flows are dependent upon the processor cycle time and traffic load conditions. This PDD is assumed to be between customers on the same Interprise America LSO, between the Remote Switch Modules (RSMs) on the same Host, or between an RSM and 5ESS, or similar, Host customers.

16.2.5.5.6.2.1.2 The objective for intra-LSO PDD is less than 310 milliseconds for 50% of all calls and less than 460 milliseconds for 95% of all calls.

16.2.5.5.6.2.2 PDD1 - B - Interprise America LSO to Another Interprise America Local LSO

16.2.5.5.6.2.2.1 The signaling protocols from an Interprise America LSO to another Interprise America LSO are assumed to employ out-of-band Common Channel Signaling System 7 (CCS7) format. Local calls, that is, calls from an Interprise America LSO to another Interprise America LSOs are assumed to have no more than one pair of Signaling Transfer Point Switches (STPSs) and no more than one data base dip.

16.2.5.5.6.2.2.2 This PDD is expected to be better than the Interprise America Long Distance objective with an average PDD of $\leq .870$ seconds with 95% ≤ 1.34 seconds.

16.2.5.5.6.2.3 PDD1 - C - Interprise America LSO to Other LSO

16.2.5.5.6.2.3.1 Calls from an Interprise America LSO to other LSOs are dependent upon the interface agreements between Interprise America and the LSO service provider and may employ CCS7, inband (MF) or a combination of both protocols.

16.2.5.5.6.2.3.2 Calls from an Interprise America LSO to another LSO via the Public Switched Telecommunications Network (PSTN), using end-to-end CCS7 signaling protocols, can expect to meet the Interprise America PDD objectives of an average of 2.0 seconds with 95% in ≤ 2.5 seconds. Calls from an Interprise America LSO via the PSTN to LSOs outside the local service area are assumed to use CCS7 signaling protocols to the Interprise America switch. The egress signaling protocols from the Interprise America Switched Network (ASN) to the many different local telephone company service providers however does not necessarily utilize CCS7 signaling. There are three basic egress signaling configuration. They are:

16.2.5.5.6.2.3.2.1 Network Inter-Connect, CCS7 between Interprise America and the local telephone company.

16.2.5.5.6.2.3.2.2 Inband Multifrequency (MF) signaling protocols without a BellSouth egress tandem in the connection.

16.2.5.5.6.2.3.2.3 Inband MF signaling protocols with a BellSouth egress tandem in the connection.

16.2.5.5.6.2.3.2.3.1 Calls from an Interprise America LSO to other LSOs outside the local service area are assumed to have multiple STPSs for 1+ traffic in the access and operator service system portion of the connection. The egress from the ASN for 1+ traffic is again dependent upon the interface agreements in that service area and may consist of CCS7 or inband MF protocols.

16.2.5.5.6.2.3.2.3.2 Calls from an Interprise America's LSO to another Interprise America LSO with a mixture of CCS7 or all inband signaling protocols are expected to receive PDDs on the average of 2.9 seconds with 95% in ≤ 6.5 seconds.

16.2.5.5.6.2.4 **PDD2 - Interprise America LSO to Operator Services**

16.2.5.5.6.2.4.1 The signaling protocols between a Interprise America LSO and the Interprise America ASN 5ESS® Operator Services Position Systems (OSPS) will employ IN-band as mutually agreed to by the Parties. Modified Operator Services Multifrequency signaling format. As with 1+ traffic, the egress from the ASN to the local service providers LSO is dependent upon the interface.

16.2.5.5.6.2.5 PDD2 - A - Interprise America LSO to operator service system 0 Only

16.2.5.5.6.2.5.1 When a "0" has been entered by the customer, timing is applied in the absence of a DTMF "#". If a "#" is not entered, the objective is for the timer to expire in 4 seconds +/- 1 second. After the timer has expired, or the "#" has been entered, the average PDD shall not exceed 2.2 seconds.

16.2.5.5.6.2.6 **PDD2 - B - 0 Plus Calls**

On calls where analysis of the first 6 digits (area code + central office code) is required, the PDD shall not exceed 2.0 seconds on the average, and 2.5 seconds in 95% of all occurrences. For calls that require analysis of the 10-digits CALLED number and the 7 digits of calling number (ANI, e.g. Automatic Charge Quotation Service) the PDD is expected to be 4.5 seconds on the average and < 5.0 seconds in 95% of all occurrences. These delays are based on the calling customer receiving a network response as described above, specifically the calling card alerting tone from the operator service system. The remaining call completion PDD to the DTN, after the customer has completed the

Operator Service function, will take the form of the PDDs discussed in PDD1-C.

16.2.5.5.6.2.7 **Impact of Local Number Portability (LNP)**

Local Number Portability will increase PDDs. If a call forwarding option is used as an interim solution for LNP, the delay due to additional switching in the local access is estimated to be 0.3 seconds (mean) and 0.4 seconds (95th percentile) in addition to the PDDs described earlier. These estimates assumes CCS7 signaling between LSOs. If inband signaling is used between LSOs, the PDD will be increased by 1.9 to 3.6 (1.7+1.9) seconds compared to the PDDs provided in the section on Post Dial Delay.

16.2.5.5.6.2.8 **Custom Local Area Subscriber Services (CLASS)**

CLASSSM features such as Calling Name Delivery can contribute to the PDD of a call. This delay is caused by the additional time (BellSouth option) before the ringing interval commences. This default delay is 3 seconds. Optional settings are available in 1 second intervals from 1 to 6 seconds. Calls to DTNs that have CLASSSM features, particularly with calling name delivery, can expect to experience from 1 to 6 seconds (3 seconds default) of additional PDD compared to the PDDs shown for PDD1-C.

16.2.5.5.6.2.9 **Partial Dial Timing**

16.2.5.5.6.2.9.1 The interval between each information digit from a customer's line, until the LSO or switching system has determined that the digit string is incomplete.

16.2.5.5.6.2.9.2 For customer lines, partial dial timing shall be ≥ 16 seconds and ≤ 24 seconds. For trunks, inband signaling time-out shall be ≥ 5 seconds and ≤ 20 seconds.

16.2.5.6 **Local Switching**

BellSouth shall provide performance equal to or better than the requirements for Local Switching set forth in Bellcore LSSGR TR-TSY-000511. Post dial delay for connections to Interprise America local operator services shall be no worse than Operator Services provided by BellSouth. Additionally, post dial delay from the Operator Services to destination numbers shall be no worse than that provided by BellSouth. Post dial delay for connections to Interprise America local Directory Assistance Services shall be no worse than Directory Assistance Services provided by BellSouth. Additionally, post dial delay from the directory system to destination numbers shall be no worse than that provided by BellSouth. Specific requirements for the Data Switching

function of Local Switching are in Section 5.3. In all cases the performance of Data Switching shall meet the general requirements stated in "General Performance Requirements." Allocation of impairments shall be negotiated between Interprise America and BellSouth.

16.2.5.7 **Operator Systems**

Operator System connections shall comply with the requirements for the Loop Combination, Local Switching, Operator Service, and Directory Assistance Service requirements.

16.2.5.8 **Common Transport**

Specific requirements for this Network Element or Ancillary Function are in the Common Transport section. In all cases the performance of this Network Element shall meet the general requirements stated Section 16.2 of this Attachment 2. Allocation of impairments shall be negotiated between Interprise America and BellSouth.

16.2.5.9 **Dedicated Transport**

Specific requirements for this Network Element are in the Dedicated Transport section. In all cases the performance of this Network Element shall meet the general requirements stated in "General Performance Requirements." Allocation of impairments shall be negotiated between Interprise America and BellSouth.

16.2.5.10 **Signaling Transfer Points**

Specific requirements for this Network Element are in the Signaling Transfer Points section. In all cases the performance of this Network Element shall meet the general requirements stated in Section 16.2 of this Attachment 2. Allocation of impairments shall be negotiated between Interprise America and BellSouth.

16.2.5.11 **Signaling Link Transport**

Specific requirements for this Network Element are in the Signaling Link Transport section. In all cases the performance of this Network Element shall meet the general requirements stated in "General Performance Requirements." Allocation of impairments shall be negotiated between Interprise America and BellSouth.

16.2.5.12 **SCPs/Databases**

The performance requirements for databases (LNP, LIDB, E911, etc.) vary depending on the database and the application(s) it supports. Database-specific performance requirements are included in the

sections addressing individual Network Elements and in applicable Bellcore documents. In all cases, the query response time, availability, accuracy, updating capabilities, and other performance parameters shall at least be at parity with those services as provided to BellSouth or other customers.

16.2.5.13 **Tandem Switching**

Specific requirements for this Network Element are in the Tandem Switching section. In all cases the performance of this Network Element shall meet the general requirements stated in Section 16.21 of this Attachment 2. Allocation of impairments shall be negotiated between Interprise America and BellSouth.

16.2.6 **Test and Verification**

16.2.6.1 BellSouth shall permit Interprise America to confirm acceptable performance of any Network Element.

16.2.6.1.1 At Interprise America's request, BellSouth will provide access to the Network Element sufficient for Interprise America to test the performance of that Network Element to Interprise America's satisfaction.

16.2.6.1.2 At Interprise America's request, BellSouth will perform tests to confirm acceptable performance and provide Interprise America with documentation of test procedures and results acceptable to Interprise America.

16.3 **Protection, Restoration, and Disaster Recovery**

16.3.1 **Scope:**

This Section refers specifically to requirements on the use of redundant network equipment and facilities for protection, restoration, and disaster recovery.

16.3.2 **Requirements**

16.3.2.1 BellSouth shall provide protection, restoration, and disaster recovery capabilities at parity with those capabilities provided for their own services, facilities and equipment (e.g., equivalent circuit pack protection ratios, facility protection ratios).

16.3.2.2 BellSouth shall provide Network Elements and Ancillary Functions equal priority in protection, restoration, and disaster recovery as provided to their own services, facilities and equipment.

16.3.2.3 BellSouth shall provide Network Elements and Ancillary Functions equal priority in the use of spare equipment and facilities as provided to their own services, facilities and equipment.

16.3.2.4 On a nondiscriminatory basis as to other BellSouth customers, BellSouth shall restore Network Elements that are specific to Enterprise America end user customers on a priority basis as Enterprise America may designate.

16.4 **Synchronization**

16.4.1 **Definition**

Synchronization is the function which keeps all digital equipment in a communications network operating at the same average frequency. With respect to digital transmission, information is coded into discrete pulses. When these pulses are transmitted through a digital communications network, all synchronous Network Elements are traceable to a stable and accurate timing source. Network synchronization is accomplished by timing all synchronous Network Elements in the network to a stratum 1 source so that transmission from these network points have the same average line rate.

16.4.2 **Technical Requirements**

The following requirements are applicable to the case where BellSouth provides synchronization to equipment that Enterprise America owns and operates within a BellSouth location. In addition, these requirements apply to synchronous equipment that is owned by BellSouth and is used to provide a Network Element to Enterprise America.

16.4.2.1 The synchronization of clocks within digital networks is divided into two parts: intra-building and inter-building. Within a building, a single clock is designated as the Building Integrated Timing Supply (BITS), which provides all of the DS1 and DS0 synchronization references required by other clocks in such building. This is referred to as intra-building synchronization. The BITS receives synchronization references from remotely located BITS. Synchronization of BITS between buildings is referred to as inter-building synchronization.

16.4.2.2 To implement a network synchronization plan, clocks within digital networks are divided into four stratum levels. All clocks in strata 2, 3, and 4 are synchronized to a stratum 1 clock, that is, they are traceable to a stratum 1 clock. A traceable reference is a reference that can be traced back through some number of clocks to a stratum 1 source. Clocks in different strata are distinguished by their free running accuracy

or by their stability during trouble conditions such as the loss of all synchronization references.

16.4.2.2.1 **Intra-Building**

16.4.2.2.1.1 Within a building, there are different kinds of equipment that require synchronization at the DS1 and DS0 rates. Synchronization at the DS1 rate is accomplished by the frequency synchronizing presence of buffer stores at various DS1 transmission interfaces. Synchronization at the DS0 rate is accomplished by using a composite clock signal that phase synchronizes the clocks. Equipment requiring DS0 synchronization frequently does not have adequate buffer storage to accommodate the phase variations among different equipment. Control of phase variations to an acceptable level is accomplished by externally timing all interconnecting DS0 circuits to a single clock source and by limiting the interconnection of DS0 equipment to less than 1,500 cable feet. Therefore, a BITS shall provide DS1 and composite clock signals when appropriate. The composite signal is a 64-kHz 5/8th duty cycle, return to zero with a bipolar violation every eighth pulse (B8RZ).

16.4.2.2.2 **Inter-Building**

16.4.2.2.2.1 BellSouth shall provide inter-building synchronization at the DS1 rate, and the BITS shall accept the primary and secondary synchronization links from BITS in other buildings. From hierarchical considerations, the BITS shall be the highest stratum clock within the building and BellSouth shall provide operations capabilities (this includes, but is not limited to: synchronization reference provisioning; synchronization reference status inquiries; timing mode status inquiries; and alarm conditions).

16.4.3 **Synchronization Distribution Requirements**

16.4.3.1 Central office BITS shall contain redundant clocks meeting or exceeding the requirements for a stratum 2 clock as specified in ANSI T1.101-1994 and Bellcore *TR-NWT-001244 Clocks for the Synchronized Network: Common Generic Criteria*.

16.4.3.2 Central office BITS shall be powered by primary and backup power sources.

16.4.3.3 If both reference inputs to the BITS are interrupted or in a degraded mode (meaning off frequency greater than twice the minimum accuracy of the BITS, loss of frame, excessive bit errors, or in Alarm Indication Signal), then the stratum clock in the BITS shall provide the necessary bridge in timing to allow the network to operate without a frame repetition or deletion (slip free) with better performance than 1 frame repetition or deletion (slip) per week.

- 16.4.3.4 DS1s multiplexed into a SONET synchronous payload envelope within an STS-n (where n is defined in ANSI T1.105-1995) signal shall not be used as reference facilities for network synchronization.
- 16.4.3.5 The total number of Network Elements cascaded from the stratum 1 source shall be minimized.
- 16.4.3.6 A Network Element shall receive the synchronization reference signal only from another Network Element that contains a clock of equivalent or superior quality (stratum level).
- 16.4.3.7 BellSouth shall select for synchronization those facilities shown to have the greatest degree of availability (absence of outages).
- 16.4.3.8 Where possible, all primary and secondary synchronization facilities shall be physically diverse (this means the maximum feasible physical separation of synchronization equipment and cabling).
- 16.4.3.9 No timing loops shall be formed in any combination of primary and secondary facilities.
- 16.4.3.10 An Operations Support System (OSS) shall continuously monitor the BITS for synchronization related failures or degradation.
- 16.4.3.11 An OSS shall continuously monitor all equipment transporting synchronization facilities for synchronization related failures or degradation.
- 16.4.3.12 For non-SONET equipment, BellSouth shall provide synchronization facilities which, at a minimum, comply with the standards set forth in ANSI T1.101-1994.
- 16.4.3.13 For SONET equipment, BellSouth shall provide synchronization facilities that have time deviation (TDEV) for integration times greater than 0.05 seconds and less than or equal to 10 seconds, that is less than or equal to 10 nanoseconds. TDEV, in nanoseconds, for integration times greater than 10 seconds and less than 1000 seconds, shall be less than 3.1623 times the square-root of the integration time. For example, for integration times of 25 seconds, TDEV shall be less than 15.8 nanoseconds.

16.5 **SS7 Network Interconnection**

16.5.1 **Definition**

Figure 9 depicts Signaling System 7 (SS7) Network Interconnection. SS7 Network Interconnection is the interconnection of !nterprise America local Signaling Transfer Point Switches (STPS) and !nterprise America

local or tandem switching systems with BellSouth STPSs. This interconnection provides connectivity that enables the exchange of SS7 messages among BellSouth switching systems and databases (DBs), Interprise America local or tandem switching systems, and other third-party switching systems directly connected to BellSouth SS7 network.

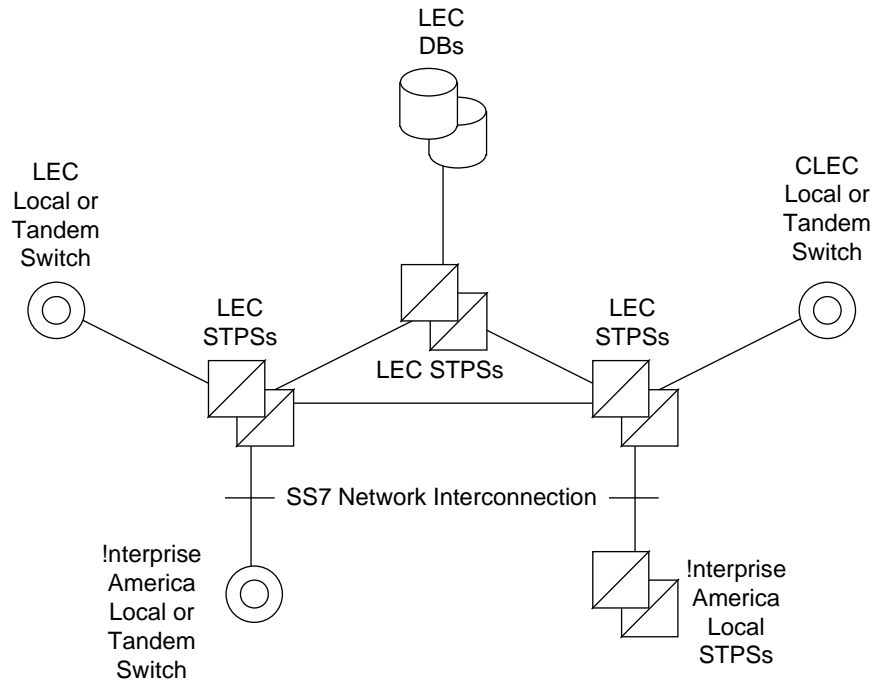

Figure 9. SS7 Network Interconnection

16.5.2 Technical Requirements

16.5.2.1 SS7 Network Interconnection shall provide connectivity to all components of the BellSouth SS7 network. These include:

16.5.2.1.1 BellSouth local or tandem switching systems;

16.5.2.1.2 BellSouth DBs; and

16.5.2.1.3 Other third-party local or tandem switching systems.

16.5.2.2 The connectivity provided by SS7 Network Interconnection shall fully support the functions of BellSouth switching systems and DBs and Interprise America or other third-party switching systems with A-link access to the BellSouth SS7 network.

16.5.2.3 In particular Figure 10 depicts a circumstance where SS7 Network Interconnection shall provide transport for certain types of Transaction

Capabilities Application Part (TCAP) messages. If traffic is routed based on dialed or translated digits between an Interprise America local switching system and a BellSouth or other third-party local switching system, either directly or via a BellSouth tandem switching system, then it is a requirement that the BellSouth SS7 network convey via SS7 Network Interconnection the TCAP messages that are necessary to provide Call Management services (Automatic Callback, Automatic Recall, and Screening List Editing) between the Interprise America local STPSs and BellSouth or other third-party local switch.

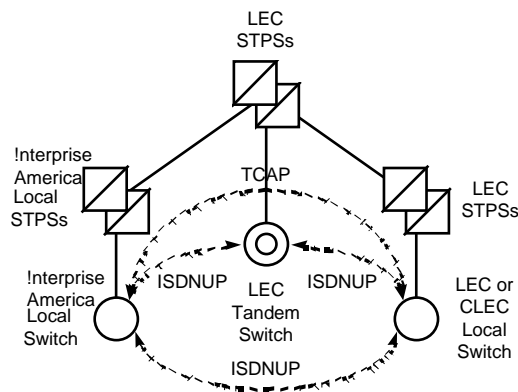

Figure 10. Interswitch TCAP Signaling for SS7 Network Interconnection

- 16.5.2.4 When the capability to route messages based on Intermediate Signaling Network Identifier (ISNI) is generally available on BellSouth STPSs, the BellSouth SS7 Network shall also convey TCAP messages using SS7 Network Interconnection in similar circumstances where the BellSouth switch routes traffic based on a Carrier Identification Code (CIC).
- 16.5.2.5 SS7 Network Interconnection shall provide all functions of the MTP as specified in ANSI T1.111 (Reference 16.5.16.5.4.16.5.4.2). This includes:
 - 16.5.2.5.1 Signaling Data Link functions, as specified in ANSI T1.111.2;
 - 16.5.2.5.2 Signaling Link functions, as specified in ANSI T1.111.3; and
 - 16.5.2.5.3 Signaling Network Management functions, as specified in ANSI T1.111.4.

- 16.5.2.6 SS7 Network Interconnection shall provide all functions of the SCCP necessary for Class 0 (basic connectionless) service, as specified in ANSI T1.112 (Reference 16.5.16.5.4.16.5.4.4). In particular, this includes Global Title Translation (GTT) and SCCP Management procedures, as specified in T1.112.4. Where the destination signaling point is a BellSouth switching system or DB, or is another third-party local or tandem switching system directly connected to the BellSouth SS7 network, SS7 Network Interconnection shall include final GTT of messages to the destination and SCCP Subsystem Management of the destination. Where the destination signaling point is a Interprise America local or tandem switching system, SS7 Network Interconnection shall include intermediate GTT of messages to a gateway pair of Interprise America local STPSs, and shall not include SCCP Subsystem Management of the destination.
- 16.5.2.7 SS7 Network Interconnection shall provide all functions of the Integrated Services Digital Network User Part (ISDNUP), as specified in ANSI T1.113 (Reference 16.5.16.5.4.16.5.4.5).
- 16.5.2.8 SS7 Network Interconnection shall provide all functions of the TCAP, as specified in ANSI T1.114 (Reference 16.5.16.5.4.16.5.4.6).
- 16.5.2.9 If and when Internetwork MTP Routing Verification Test (MRVT) and SCCP Routing Verification Test (SRVT) become approved ANSI standards and available capabilities of BellSouth STPSs, SS7 Network Interconnection shall provide these functions of the OMAP.
- 16.5.2.10 SS7 Network Interconnection shall be equal to or better than the following performance requirements:
- 16.5.2.10.1 MTP Performance, as specified in ANSI T1.111.6;
 - 16.5.2.10.2 SCCP Performance, as specified in ANSI T1.112.5; and
 - 16.5.2.10.3 ISDNUP Performance, as specified in ANSI T1.113.5.
- 16.5.3 **Interface Requirements**
- 16.5.3.1 BellSouth shall offer the following SS7 Network Interconnection options to connect Interprise America or Interprise America-designated local or tandem switching systems or STPSs to the BellSouth SS7 network:
- 16.5.3.1.1 A-link interface from Interprise America local or tandem switching systems; and
 - 16.5.3.1.2 D-link interface from Interprise America STPSs.

16.5.3.2 Each interface shall be provided by one or more sets (layers) of signaling links, as follows:

16.5.3.2.1 An A-link layer shall consist of two links, as depicted in Figure 11.

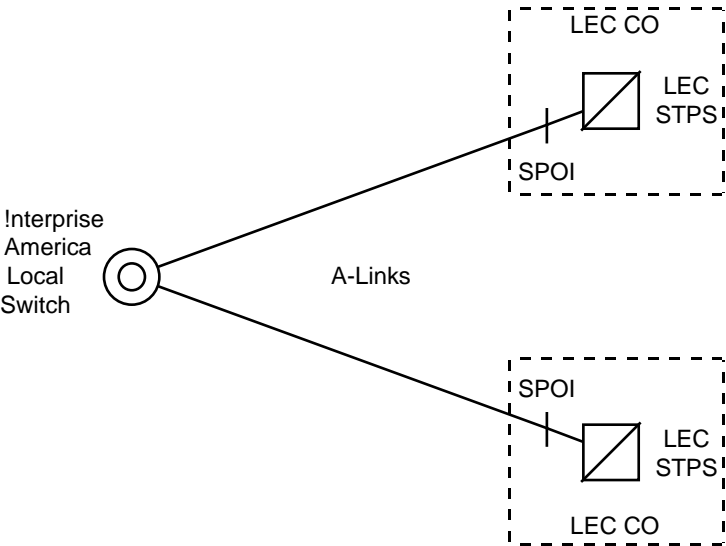

16.5.3.2.2 **Figure 11. A-Link Interface**

16.5.3.2.3 A D-link layer shall consist of four links, as depicted in Figure 12.

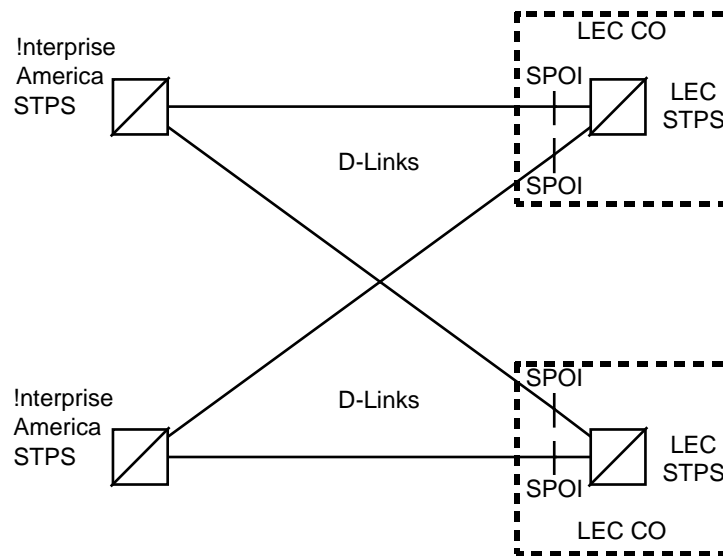

Figure 12. D-Link Interface

- 16.5.3.3 The Signaling Point of Interconnection (SPOI) for each link shall be located at a cross-connect element, such as a DSX-1, in the Central Office (CO) where the BellSouth STPS is located. There shall be a DS1 or higher rate transport interface at each of the SPOIs. Each signaling link shall appear as a DS0 channel within the DS1 or higher rate interface. BellSouth shall offer higher rate DS1 signaling links for interconnecting Interprise America local switching systems or STPSs with BellSouth STPSs as soon as these become approved ANSI standards and available capabilities of BellSouth STPSs. BellSouth and Interprise America will work jointly to establish mutually acceptable SPOI.
- 16.5.3.4 BellSouth CO shall provide intraoffice diversity between the SPOIs and the BellSouth STPS, so that no single failure of intraoffice facilities or equipment shall cause the failure of both D-links in a layer connecting to a BellSouth STPS. BellSouth and Interprise America will work jointly to establish mutually acceptable SPOI.
- 16.5.3.5 The protocol interface requirements for SS7 Network Interconnection include the MTP, ISDNUP, SCCP, and TCAP. These protocol interfaces shall conform to the following specifications:
- 16.5.3.5.1 Bellcore GR-905-CORE, Common Channel Signaling Network Interface Specification (CCSNIS) Supporting Network Interconnection, Message

- Transfer Part (MTP), and Integrated Services Digital Network User Part (ISDNUP);
- 16.5.3.5.2 Bellcore GR-1428-CORE, CCS Network Interface Specification (CCSNIS) Supporting Toll Free Service;
 - 16.5.3.5.3 Bellcore GR-1429-CORE, CCS Network Interface Specification (CCSNIS) Supporting Call Management Services; and
 - 16.5.3.5.4 Bellcore GR-1432-CORE, CCS Network Interface Specification (CCSNIS) Supporting Signaling Connection Control Part (SCCP) and Transaction Capabilities Application Part (TCAP).
 - 16.5.3.6 BellSouth shall set message screening parameters to block accept messages from Interprise America local or tandem switching systems destined to any signaling point in the BellSouth SS7 network with which the Interprise America switching system has a legitimate signaling relation.
 - 16.5.4 SS7 Network Interconnection shall be equal to or better than all of the requirements for SS7 Network Interconnection set forth in the following technical references:
 - 16.5.4.1 ANSI T1.110-1992 American National Standard Telecommunications - Signaling System Number 7 (SS7) - General Information;
 - 16.5.4.2 ANSI T1.111-1992 American National Standard for Telecommunications - Signaling System Number 7 (SS7) - Message Transfer Part (MTP);
 - 16.5.4.3 ANSI T1.111A-1994 American National Standard for Telecommunications - Signaling System Number 7 (SS7) - Message Transfer Part (MTP) Supplement;
 - 16.5.4.4 ANSI T1.112-1992 American National Standard for Telecommunications - Signaling System Number 7 (SS7) - Signaling Connection Control Part (SCCP);
 - 16.5.4.5 ANSI T1.113-1995 American National Standard for Telecommunications - Signaling System Number 7 (SS7) - Integrated Services Digital Network (ISDN) User Part;
 - 16.5.4.6 ANSI T1.114-1992 American National Standard for Telecommunications - Signaling System Number 7 (SS7) - Transaction Capabilities Application Part (TCAP);
 - 16.5.4.7 ANSI T1.115-1990 American National Standard for Telecommunications - Signaling System Number 7 (SS7) - Monitoring and Measurements for Networks;

- 16.5.4.8 ANSI T1.116-1990 American National Standard for Telecommunications - Signaling System Number 7 (SS7) - Operations, Maintenance and Administration Part (OMAP);
- 16.5.4.9 ANSI T1.118-1992 American National Standard for Telecommunications - Signaling System Number 7 (SS7) - Intermediate Signaling Network Identification (ISNI);
- 16.5.4.10 Bellcore GR-905-CORE, Common Channel Signaling Network Interface Specification (CCSNIS) Supporting Network Interconnection, Message Transfer Part (MTP), and Integrated Services Digital Network User Part (ISDNUP);
- 16.5.4.11 Bellcore GR-954-CORE, CCS Network Interface Specification (CCSNIS) Supporting Line Information Database (LIDB) Service;
- 16.5.4.12 Bellcore GR-1428-CORE, CCS Network Interface Specification (CCSNIS) Supporting Toll Free Service;
- 16.5.4.13 Bellcore GR-1429-CORE, CCS Network Interface Specification (CCSNIS) Supporting Call Management Services; and,
- 16.5.4.14 Bellcore GR-1432-CORE, CCS Network Interface Specification (CCSNIS) Supporting Signaling Connection Control Part (SCCP) and Transaction Capabilities Application Part (TCAP).

16.6 **Network Interconnection**

16.6.1 **Technical Requirements**

- 16.6.1.1 When requested by Interprise America, BellSouth shall provide interconnections between BellSouth Network Elements provided to Interprise America and Interprise America's network at transmission rates designated by Interprise America, including, but not limited to DS1, DS3, and STS-1.
- 16.6.1.2 Traffic shall be combined and routed as follows:
 - 16.6.1.2.1 BellSouth shall provide direct trunks for local and intraLATA traffic (except 911, directory assistance, operator services, and other services that may require special routing) and, at Interprise America's request, BellSouth shall allow Interprise America to route such traffic either directly to a BellSouth's tandem or directly to a BellSouth end-office.
 - 16.6.1.2.2 At Interprise America's request, BellSouth shall receive Interprise America traffic destined to BellSouth Operator Systems Network Element, on trunks from a Interprise America end-office or a Interprise America tandem.

16.6.1.2.3 At Interprise America's request, BellSouth shall receive Interprise America CAMA-ANI (Centralized Automatic Message Accounting - Automatic Number identification) traffic destined to BellSouth B911 PSAPs, or E911 tandems, on trunks from a Interprise America end-office.

16.6.1.2.4 **DELETED**

16.6.1.3 When requested by Interprise America and a third party carrier, BellSouth shall provide interconnections between Interprise America's network, and the other carrier's network through BellSouth network at transmission rates designated by Interprise America, including, but not limited to DS1, DS3, and STS-1. BellSouth shall combine and route traffic to and from other local carriers and interLATA carriers through BellSouth network, and at Interprise America's request, BellSouth shall record and keep records of such traffic for Interprise America billing purposes.

16.6.1.4 The parties agree to implement the most efficient trunking arrangement to exchange all traffic unless otherwise agreed. For purposes of this Section, "most efficient" means the fewest number of trunks required to carry a forecasted load at P.01 grade of service. BellSouth and Interprise America will utilize two-way trunks for origination and termination of all traffic as depicted in the following trunking diagram.

Most Efficient Interconnection

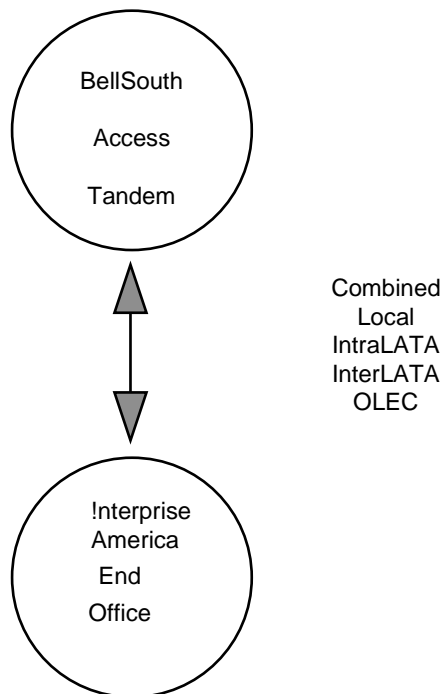

- 16.6.1.5 Interprise America shall be allowed to mix local, intraLATA and interLATA toll and wireless traffic over the same trunks. Interprise America shall report traffic to BellSouth using percentage use factors and shall grant BellSouth reasonable audit rights to ensure the accuracy of the factors. Interprise America shall be required to share the necessary call detail records with BellSouth. Interprise America and BellSouth shall work together to develop a mutually agreed upon solution for billing mixed traffic.
- 16.6.1.6 Interprise America shall establish their POIs at appropriate points within BellSouth's network to comport with minimum standards of technical feasibility regarding network reliability and security. BellSouth shall make its best efforts to work with Interprise America to mutually determine acceptable mid-span meet points within BellSouth's network without compromising BellSouth's ability to retain control of its network and without requiring BellSouth to implement and maintain a vast array of additional equipment brands (manufacture) types and configurations. Interprise America and BellSouth shall work together to develop mutually acceptable arrangements for compensation and safeguards for network control and reliability, including the development of acceptable types of brands of equipment to be used with mid-span meets.
- 16.6.1.7 All trunking provided by BellSouth shall adhere to the applicable performance requirements set forth in Section 16.2 of Attachment 2.
- 16.6.1.8 At Interprise America's request, BellSouth shall provide for overflow routing from a given high usage trunk group or groups onto another final tandem trunk group.
- 16.6.1.9 BellSouth and Interprise America shall agree on the establishment of two-way trunk groups for the exchange of traffic for other IXCs. These trunk groups can be provided in a "meet point" arrangement.
- 16.6.1.10 Interconnection shall be made available upon Interprise America's request at any technically feasible point of interface. At Interprise America's option, Interprise America shall interconnect at one or more access tandems or local tandems per LATA for routing traffic within BellSouth's serving territory. Should Interprise America choose to connect at one access tandem within the LATA it may, at its discretion, utilize or dedicate trunks between access tandems. Interprise America and BellSouth shall work together to mutually resolve issues regarding recording, billing and administration before this type of interconnection is implemented.
- 16.6.1.11 Should a call end up traversing multiple offices, Interprise America agrees to pay the appropriate charges for such call. If Interprise America

opts for a network configuration arrangement that may result in a diminution of service quality, e.g., post dialing delay, Interprise America and BellSouth shall mutually determine what service quality impacts, if any, such an arrangement will have before Interprise America implements that network configuration. Interprise America recognizes and affirms that certain characteristics of quality of service, e.g., post dialing delay, may be impacted in cases where Interprise America traffic traverses multiple tandems given Interprise America's interconnection at a single tandem in a given LATA. All trunk interconnections shall be provided, including, SS7, MF, DTMF, DialPulse, PRI-ISDN (where available), DID (Direct Inward Dialing), CAMA-ANI, and trunking necessary so that interim LNP can be provided.

16.6.1.12 Trunk Interface Requirements

16.6.1.12.1 B911/E911 Trunks

16.6.1.12.1.1 DELETED

16.6.1.12.1.2 If a municipality has converted to E911 service, Interprise America will forward 911 calls to the appropriate E911 primary tandem, along with ANI, based upon the current E911 end office to tandem homing arrangement as provided by BellSouth. If the primary tandem trunks are not available, Interprise America will alternatively route the call to a designated 7-digit local number residing in the appropriate PSAP. This call will be transported over BellSouth's interoffice network and will not carry the ANI of the calling party, which is in parity with BellSouth's handling of 911 calls from its customers.

16.6.1.12.2 S911 Trunks

16.6.1.12.3 Local Switch and Access Tandem Trunks

16.6.1.12.3.1 BellSouth shall provide trunks groups provisioned exclusively to carry intraLATA traffic, as designated by Interprise America.

16.6.1.12.3.2 BellSouth shall provide trunk groups provisioned exclusively to carry interLATA traffic, as designated by Interprise America.

16.6.1.12.3.3 BellSouth shall provide SS7 trunks which provide SS7 interconnection. At Interprise America's request, MF trunks may be substituted for SS7 trunks where applicable.

16.6.1.12.3.4 BellSouth shall simultaneous route calls based on dialed digits (in accordance with the standard GR-317-CORE), and Carrier Identification

Code (in accordance with the standard GR-394-CORE) over a single SS7 trunk group.

16.6.1.12.4 BellSouth Operator Services Trunk

16.6.1.12.4.1 For traffic from BellSouth's network to Interprise America for Operator Services, BellSouth shall provide one trunk group per NPA served by the local BellSouth switch.

16.6.1.12.4.2 BellSouth shall provide such trunks as one-way trunks from BellSouth network to the Interprise America network.

16.6.2 Network Interconnection between BellSouth and Interprise America shall meet or exceed all of the requirements for Network Interconnection set forth in the following technical references:

16.6.2.1 BellCore GR-317-CORE, Switching System generic requirements for Call Control Using the Integrated Services Digital Network User Part (ISDNUP), Bellcore, February, 1994;

16.6.2.2 BellCore GR-394-CORE, Switching System generic requirements for Interexchange Carrier Interconnection Using the Integrated Services Digital Network User Part (ISDNUP), Bellcore, February, 1994;

16.6.2.3 BellCore FR-NWT-000271, OSSGR Operator Services Systems generic requirements, Bellcore, 1994 Edition; and

16.6.2.4 BellCore FR-NWT-000064, LATA Switching Systems Generic Requirements (LSSGR), Bellcore, 1994 Edition.

16.7 Basic 911 and E911

16.7.1 Definition

Basic 911 and E911 is an additional requirement that provides a caller access to the applicable emergency service bureau by dialing a 3-digit universal telephone number (911).

16.7.2 Requirements

16.7.2.1 Basic 911 shall collect 911 calls from one or more local exchange switches that serve a geographic area. It shall then send these calls to the correct authority designated to receive such calls.

16.7.2.2 E911 shall provide additional routing flexibility for 911 calls. E911 shall use customer data, contained in the Automatic Location Identification/Data Management System (ALI/DMS), to determine to which Public Safety Answering Point (PSAP) to route the call.

- 16.7.2.3 **DELETED**
- 16.7.2.4 Basic 911 and E911 functions provided to Interprise America shall be at least at parity with the support and services that BellSouth provides to its customers for such similar functionality.
- 16.7.2.5 Basic 911 and E911 access from Local Switching shall be provided to Interprise America in accordance with the following:
- 16.7.2.5.1 BellSouth shall conform to all state regulations concerning emergency services;
- 16.7.2.5.2 BellSouth shall route calls to the appropriate PSAP.
- 16.7.2.5.3 For B911, BellSouth shall provide voice only to the appropriate PSAP.
- 16.7.2.5.4 For E911, BellSouth shall use the process as described in the E911 Local Exchange Carrier Guide for Facility-Based Providers (ALEC Guide) to update and maintain customer information in the ALI/DMS database. BellSouth shall provide and validate customer information resident or entered into the ALI/DMS database.
- 16.7.2.5.5 **DELETED**
- 16.7.2.6 Basic 911 and E911 access from the Interprise America local switch shall be provided to Interprise America in accordance with the following:
- 16.7.2.6.1 If required by Interprise America, BellSouth shall interconnect direct trunks from the Interprise America network to the B911 PSAP, or the E911 tandems as designated by Interprise America. Such trunks may alternatively be provided by Interprise America.
- 16.7.2.6.2 For E911, BellSouth, shall receive data from Interprise America as described in the ALEC Guide (electronically via FTS or NDM) Errors will be mechanically faxed to Interprise America shortly after the errors are detected by the update process. Interprise America will transmit daily update files for "batch" processing within 24 hours of receipt of a "good file".
- 16.7.2.6.3 BellSouth shall provide Interprise America with an initial Master Street and Address Guide (MSAG) (paper or magnetic tape) no later than 30 days after the effective date of this Agreement and will provide updates of this MSAG quarterly.
- 16.8 Electronic Interface
- BellSouth shall provide real time Electronic Interfaces ("EI") for transferring and receiving Service Orders and Provisioning data and materials (e.g., access Street Address Guide ("SAG") and Telephone

Number Assignment database) as specified in Attachment 15. These interfaces shall be administered through a gateway that will serve as a point of contact for the transmission of such data from Interprise America to BellSouth, and from BellSouth to Interprise America. The requirements and implementation of such a data transfer system shall be negotiated in good faith by the parties as specified in Attachments 4, 5 and 15 of this Agreement. Interprise America and BellSouth have agreed upon interim solutions described in Attachments 4, 5 and 15. Until such time as a gateway addressing Pre-Ordering and Provisioning interfaces is established, BellSouth shall provide Interprise America Customers with the same quality of service BellSouth provides itself, a subsidiary, an Affiliate or any other customer.

TABLE OF CONTENTS

SERVICE DESCRIPTION: ANCILLARY FUNCTIONS

1. Introduction 1

2. Collocation 1

3. RIGHTS OF WAY (ROW), CONDUITS AND POLE ATTACHMENTS..... 7

SERVICE DESCRIPTION: ANCILLARY FUNCTIONS

1. **Introduction**

This Attachment sets forth the descriptions and requirements for Ancillary Functions that BellSouth agrees to offer to Interprise America under this Agreement. Interprise America may use any Ancillary Function to provide any feature, function, or service option that such Ancillary Function is capable of providing or any feature, function, or service option that is described in the technical references identified herein.

2. **Collocation**

2.1 **Definition** - Collocation means the right of Interprise America to obtain space in BellSouth premises and to place equipment in such spaces to interconnect with BellSouth network.

2.2 **Technical Requirements**

2.2.1 BellSouth shall provide space, as requested by Interprise America, to meet Interprise America's needs for placement of equipment, interconnection, or provision of service. Interprise America and BellSouth will jointly establish a written business process within ninety (90) days after the execution this Agreement by which such space can be procured.

2.2.1.1 Unless abatement of an Environmental Hazard or Harzardous Materials is required, intervals for physical collocation shall be a maximum of ninety (90) days from the date BellSouth receives Interprise America's firm order request. Requirements, terms and conditions for virtual collocation will be pursuant to Section 20 of BellSouth's FCC #1 tariff.

2.2.2 BellSouth shall provide intraoffice facilities (e.g., DS0, DS1, DS3, OC3, OC12, OC48, and STS-1 terminations) as requested by Interprise America to meet Interprise America's need for placement of equipment, interconnection, or provision of service.

2.2.3 BellSouth agrees to allow Interprise America's employees and designated agents unrestricted access to Interprise America dedicated space in manned BellSouth offices twenty-four (24) hours per day each day of the week. BellSouth may place reasonable security restrictions on access by Interprise America's employees and designated agents to the Interprise America collocated space in unmanned BellSouth offices. Notwithstanding, BellSouth agrees that such space shall be available to Interprise America's employees and designated agents twenty-four (24) hours per day each day of the week. A security escort may be required in some locations for non-BellSouth personnel. Interprise America agrees to ensure each employee, agent or contractor hired by and working on behalf of Interprise America within BellSouth's central office openly wears a

picture identification badge reflecting the individual's name, Interprise America's name/logo or affiliation to Interprise America.

- 2.2.4 Interprise America may collocate the amount and type of equipment it deems necessary in its collocated space (e.g., Interprise America utilizing its SONET termination equipment in the collocated space to provide a hub for OC3/OC48 rings). BellSouth shall not restrict the types of equipment or vendors of equipment to be installed provided such equipment is used to provide Telecommunication Services as defined in the Act. Such equipment must meet applicable industry standards.
- 2.2.5 BellSouth agrees to provide Interprise America with interconnection of Interprise America's collocated facilities to those of other carriers that are collocated in the same BellSouth Premise.
- 2.2.6 Interprise America may select its own vendors for all required engineering and installation services associated with its collocated equipment. (BellSouth shall not require Interprise America to utilize BellSouth's internal engineering or installation work forces for the engineering and installation of Interprise America's collocated equipment.) Vendors utilized by Interprise America must be on BellSouth's list of certified vendors.
- 2.2.7 BellSouth shall provide basic telephone service at the tariffed rate for basic service with a connection jack as requested by Interprise America from BellSouth for the collocated space. Upon Interprise America's request, this service shall be available at the Interprise America collocated space on the day that the space is turned over to Interprise America by BellSouth.
- 2.2.8 BellSouth shall provide adequate lighting, ventilation, power, heat, air conditioning, and other environmental conditions for Interprise America's space and equipment. These environmental conditions shall adhere to Bell Communication Research (BellCore) Network Equipment-Building System (NEBS) standards TR-EOP-000063.
- 2.2.9 BellSouth shall provide access to eyewash stations, shower stations, bathrooms, and drinking water within the collocated facility on a twenty-four (24) hours per day, seven (7) days per week basis for Interprise America personnel and its designated agents.
- 2.2.10 Interprise America may request dual fiber entrance to the BellSouth Central Office. Where physically separate paths are not available, BellSouth will allow Interprise America to provide physical separation of the fibers within the riser and/or support structure by the placement of conduit or similar covering around one of the entrance fibers. This covering will be no larger than necessary to accommodate the protection of this one fiber.

- 2.2.11 BellSouth shall ensure protection of Interprise America's proprietary customer information. Any collocation arrangement shall include provisions for BellSouth protecting Interprise America's proprietary information.
- 2.2.12 BellSouth shall participate in and adhere to negotiated service guarantees, DMOQs, and ISO reviews.
- 2.2.13 Within three (3) business days of Interprise America's written request, BellSouth shall identify any known Environmental Hazard or Hazardous Materials in the space provided for placement of equipment and interconnection.
- 2.2.13.1 BellSouth shall allow Interprise America to perform any environmental site investigations, including, but not limited to, asbestos surveys, which Interprise America deems to be necessary in support of its collocation needs, at Interprise America's expense.
- 2.2.13.2 If the space provided for the placement of equipment, interconnection, or provision of service contains an Environmental Hazard or Hazardous Material, particularly but not limited to asbestos, lead paint or radon, which makes the placement of such equipment or interconnection hazardous, BellSouth shall offer an alternative space, if available, for Interprise America's consideration.
- 2.2.14 BellSouth shall provide Interprise America with written notice five (5) business days prior to those instances where BellSouth or its subcontractors may be performing work in the general area of the collocated space occupied by Interprise America, or in the general area of the AC and DC power plants which support Interprise America equipment that may directly impact Interprise America's equipment arrangement, facilities, or power supply. BellSouth will inform Interprise America by telephone of any emergency related activity that BellSouth or its subcontractors may be performing in the general area of the collocated space occupied by Interprise America, or in the general area of the AC and DC power plants which support Interprise America equipment that may directly impact Interprise America's equipment arrangement, facilities, or power supply. Notification of such emergency related activity shall be made immediately prior to the start of the activity so that Interprise America can take any action required to monitor or protect its service.
- 2.2.15 BellSouth shall construct the collocated space in compliance with Interprise America's collocation request for cable holes, ground bars, doors, and convenience outlets. Any deviation to Interprise America's request will be jointly negotiated with BellSouth.

- 2.2.16 Interprise America and BellSouth will complete an acceptance walk through of all collocated space requested from BellSouth. BellSouth will correct any deviations to Interprise America's original or jointly amended request within five (5) business days after the walk through or a negotiated time frame, depending on the magnitude of the deviation, at BellSouth's expense. Any other additions or changes to the original or jointly amended request will be at Interprise America's expense.
- 2.2.17 The Point of Termination bay will be part of cage walls of Interprise America's designated space. The logistics and floor plan drawing will be discussed at the first joint planning meeting as referenced in 2.2.18 below.
- 2.2.18 A joint planning meeting between BellSouth and Interprise America will commence within a maximum of thirty (30) days from BellSouth's receipt of a complete and accurate firm order and the payment of agreed to fees. The parties will exchange the following information at such meeting and establish scheduling for multi-site installations:
- 2.2.18.1 Telephone Equipment drawings depicting the exact path with dimensions, for Interprise America Outside Plant Fiber ingress and egress into collocated space.
- 2.2.18.2 Power feeder fuse slot assignment on the BellSouth Battery Distribution Frame Bay.
- 2.2.18.3 Work restriction guidelines.
- 2.2.18.4 Contact access and escalation process to the following areas:
- Engineering
 - Physical & Logical Security
 - Provisioning
 - Billing
 - Operations
 - Site and Building Managers
 - Environmental and Safety
- 2.2.19 BellSouth shall provide the Interprise America selected certified equipment engineering vendor access to the Engineering Records Mark-up and Assignment (ERMA) Database for certified vendor power supply assignments.
- 2.2.20 BellSouth shall provide positive confirmation to Interprise America when construction of Interprise America collocated space is 50% completed. This confirmation shall also include confirmation of the scheduled completion and turnover dates. Interprise America agrees to place operational telecommunications equipment in the BellSouth Premises and

connect with BellSouth's network within one-hundred eighty (180) days of the space turnover date. Interprise America may request an extension beyond one hundred eighty (180) days upon demonstration by Interprise America that Interprise America has made a good faith effort to complete installation by the prescribed date or circumstances beyond its reasonable control prevented Interprise America from completing installation by the prescribed date. Provided Interprise America has shown a good faith effort or that circumstances were beyond its control, BellSouth shall not unreasonably withhold its consent to such extension. If Interprise America fails to place operational telecommunications equipment in the Collocation Space within the 180 days or within the allotted extension period, BellSouth shall provide Interprise America written notice of such failure. If such failure continues for a period of thirty (30) days after receipt of written notice from BellSouth, then BellSouth shall have no further obligation to Interprise America under this section of the Agreement and Interprise America shall forfeit its rights to use the space. Interprise America shall be liable to BellSouth for all costs reasonably incurred by BellSouth in preparing the Collocation Space. For the purpose of this paragraph, Interprise America's telecommunications equipment will be operational when cross-connected to BellSouth's network for the purpose of service provision.

- 2.2.21** BellSouth will reimburse Interprise America in an amount equal to the Interprise America expenditures incurred as a result as a direct result of delays in the negotiated completion and turnover dates caused by BellSouth.
- 2.2.22** Power as referenced in this document refers to any electrical power source supplied by BellSouth for Interprise America equipment. It includes all superstructure, infrastructure, and overhead facilities, including, but not limited to, cable, cable racks and bus bars. BellSouth will supply power to support Interprise America equipment at equipment specific DC and AC voltages. BellSouth shall supply power and power infrastructure to Interprise America at parity with that provided by BellSouth to itself or to any third party. BellSouth's performance, availability, or restoration shall meet BellCore/NEBS standards. If BellSouth's performance, availability, or restoration fall below BellCore/NEBS standards, BellSouth will bring itself into compliance as soon as technologically feasible.
- 2.2.22.1** Central office power supplied by BellSouth into the Interprise America equipment area, shall be supplied in the form of power feeders (cables) on cable racking into the designated Interprise America equipment area. The power feeders (cables) shall efficiently and economically support the requested quantity and capacity of Interprise America equipment. The

termination location shall be as requested by Interprise America. Any deviations will be jointly agreed upon by BellSouth and Interprise America.

- 2.2.22.2 BellSouth shall provide power as requested by Interprise America to meet Interprise America's need for placement of equipment, interconnection, or provision of service.
- 2.2.22.3 BellSouth power equipment supporting Interprise America's equipment shall:
 - 2.2.22.3.1 Comply with applicable industry standards (e.g., BellCore, and NEBS or manufacturer's equipment power requirement specifications for equipment installation, and physical equipment layout. Manufacturer's cabling practices shall comply with industry standards that meet or exceed Bellcore or NEBS standards;
 - 2.2.22.3.2 Have redundant power feeds with physical diversity and battery back-up at parity with that provided for similar BellSouth equipment;
 - 2.2.22.3.3 **DELETED**
 - 2.2.22.3.4 Provide central office ground, connected to a ground electrode located within the Interprise America collocated space, at a location which meets BellSouth standards and is jointly agreed upon by the parties at the initial planning meeting identified in Section 2.2.18 of this Attachment 3; and
 - 2.2.22.3.5 Provide feeder capacity and quantity to support the ultimate equipment layout for Interprise America equipment in accordance with Interprise America's collocation request.
 - 2.2.22.3.6 BellSouth shall, within ten (10) days of Interprise America's request:
 - 2.2.22.3.6.1 Provide an installation sequence and access that will allow installation efforts in parallel without jeopardizing personnel safety or existing Interprise America services;
 - 2.2.22.3.6.2 **DELETED**
 - 2.2.22.3.6.3 Provide cabling that adheres to Bell Communication Research (BellCore) Network Equipment-Building System (NEBS) standards TR-EOP-000063; and
 - 2.2.22.3.6.4 Provide Lock Out-Tag Out and other electrical safety procedures and devices in conformance with the most stringent of OSHA or industry guidelines.
 - 2.2.22.3.6.5 BellSouth will provide Interprise America with written notification within ten (10) business days of any scheduled AC or DC power work or related

activity in the collocated facility that will or might cause an outage or any type of power disruption to Interprise America equipment located in BellSouth facility. BellSouth shall provide Interprise America immediate notification by telephone of any emergency power activity that would impact Interprise America equipment.

- 2.3 BellSouth will permit Interprise America to inspect supporting documents for contracted work done on behalf of Interprise America (i.e., AIA document G702).

2.4 **Physical Security Requirements**

- 2.4.1 BellSouth agrees to use card access readers (door locks) or equivalent that will provide an audit trail of persons entering doors of facilities that have Interprise America equipment or equipment enclosures.

- 2.4.2 BellSouth will ensure that the building area which houses Interprise America equipment is adequately secured and monitored to prevent entry. BellSouth will provide timely notification to the Interprise America personnel designated on Interprise America's enclosures of an actual or attempted security breach to space housing Interprise America equipment or Interprise America enclosures when BellSouth has actual knowledge of an actual or threatened security breach.

- 2.5 Technical References - BellSouth agrees to comply with all BellCore and ANSI standards that are directly applicable to construct, supply and maintain collocation. Such standards include:

National Electrical Code (NEC)
NEBS Generic Engineering Requirements for System Assembly
and Cable Distribution
Generic Requirements for -24, -48, -130, and -140 Volt Central
Office Power Plant Rectifiers. (BellCore)

3. **RIGHTS OF WAY (ROW), CONDUITS AND POLE ATTACHMENTS**

This Section 3, Poles, Conduits and Rights-of-Way to Attachment Ancillary Functions to the Agreement sets forth the terms and conditions under which BellSouth shall afford to Interprise America access to BellSouth's poles, ducts, conduits and Rights-of-way, pursuant to the Act.

3.1 **DEFINITIONS**

- 3.1.1 Definitions in General. Except as the context otherwise requires, the terms defined in this Section shall, as used in this Section, have the meanings set forth in 3.1.2 through 3.1.31.

- 3.1.2 Agreement. When capitalized, the term "Agreement" refers to the Interconnection Agreement dated September 15, 1997, by and between BellSouth and Interprise America.
- 3.1.3 Anchor. The term "anchor" refers to a device, structure, or assembly which stabilizes a pole and holds it in place. An anchor assembly may consist of a rod and fixed object or plate, typically embedded in the ground, which is attached to a guy strand or guy wire, which, in turn, is attached to the pole. The term "anchor" does not include the guy strand which connects the anchor to the pole and includes only those anchors which are owned by BellSouth, as distinguished from anchors which are owned and controlled by other persons or entities.
- 3.1.4 Anchor/guy strand. The term "anchor/guy strand" refers to supporting wires, typically stranded together, or other devices attached to a pole and connecting that pole to an anchor or to another pole for the purpose of increasing pole stability. The term "anchor/guy strand" includes, but is not limited to, strands sometimes referred to as "anchor strands," "down guys," "guy strands," and "pole-to-pole guys."
- 3.1.5 Communications Act of 1934. The terms "Communications Act of 1934" and "Communications Act" refer to the Communications Act of June 19, 1934, 48 Stat. 1064, as amended, including the provisions codified as 47 U.S.C. Sections 151 et seq. The Communications Act includes the Pole Attachment Act of 1978, as defined in this Article 3.1.
- 3.1.6 Assigned. The term "assigned", when used with respect to conduit or duct space or pole attachment space, refers to any space in such conduit or duct or on such pole that is occupied by a telecommunications service provider or a municipal or other governmental authority. To ensure the judicious use of poles and conduits, space "assigned" to a telecommunications service provider must be physically occupied by the service provider, be it BellSouth or a new entrant, within twelve (12) months of the space being "assigned".
- 3.1.7 Available. The term "available", when used with respect to conduit or duct space or pole attachment space, refers to any usable space in such conduit or duct or on such pole not assigned to a specific provider at the applicable time.
- 3.1.8 Conduit occupancy. The terms "conduit occupancy" and "occupancy" refer to the presence of wire, cable, optical conductors, or other facilities within any portion of BellSouth's conduit system.
- 3.1.9 Conduit system. The term "conduit system" refers to any combination of ducts, conduits, manholes, and handholes joined to form an integrated

whole. In this Section, the term refers to conduit systems owned or controlled by BellSouth.

- 3.1.10 Cost. The term "cost" as used herein refers to charges made by BellSouth to Interprise America for specific work performed, and shall be (a) the actual charges made by subcontractors to BellSouth for work and/or, (b) if the work was performed by BellSouth employees, the rates set forth in Part 4 of this Agreement shall apply for such work.
- 3.1.11 Duct. The term "duct" refers to a single enclosed tube, pipe, or channel for enclosing and carrying cables, wires, and other facilities. As used in this Section, the term "duct" includes "inner ducts" created by subdividing a duct into smaller channels.
- 3.1.12 Facilities. The terms "facility" and "facilities" refer to any property or equipment utilized in the provision of telecommunication services.
- 3.1.13 The acronym "FCC" refers to the Federal Communications Commission.
- 3.1.14 Inner-Duct. The term "inner-duct" refers to a pathway created by subdividing a duct into smaller channels.
- 3.1.15 Joint User. The term "joint user" refers to a utility which has entered into an agreement with BellSouth providing reciprocal rights of attachment of facilities owned by each party to the poles, ducts, conduits and rights-of-way owned by the other party.
- 3.1.16 Licensee. The term "licensee" refers to a person or entity which has entered or may enter into an agreement or arrangement with BellSouth permitting such person or entity to place its facilities in BellSouth's conduit system or attach its facilities to BellSouth's poles or anchors.
- 3.1.17 Lashing. The term "lashing" refers to the attachment of a licensee's sheath or inner-duct to a supporting strand.
- 3.1.18 License. The term "license" refers to any license issued pursuant to this Agreement and may, if the context requires, refer to conduit occupancy or pole attachment licenses issued by BellSouth prior to the date of this Agreement.
- 3.1.19 Make-Ready work. The term "make-ready work" refers to all work performed or to be performed to prepare BellSouth's conduit systems, poles or anchors and related facilities for the requested occupancy or attachment of Interprise America's facilities. "Make-Ready work" includes, but is not limited to, clearing obstructions (e.g., by "rodding" ducts to ensure clear passage), the rearrangement, transfer, replacement, and removal of existing facilities on a pole or in a conduit system where such

work is required solely to accommodate Interprise America's facilities and not to meet BellSouth's business needs or convenience. "Make-Ready work" may require "dig-ups" of existing facilities and may include the repair, enlargement or modification of BellSouth's facilities (including, but not limited to, conduits, ducts, handholes and manholes) or the performance of other work required to make a pole, anchor, conduit or duct usable for the initial placement of Interprise America's facilities.

- 3.1.20 Manhole. The term "manhole" refers to an enclosure, usually below ground level and entered through a hole on the surface covered with a cast iron or concrete manhole cover, which personnel may enter and use for the purpose of installing, operating, and maintaining facilities in a conduit.
- 3.1.21 Occupancy. The term "occupancy" shall refer to the physical presence of telecommunication facilities in a duct, on a pole, or within a Right-of-way.
- 3.1.22 Person acting on Interprise America's behalf. The terms "person acting on Interprise America's behalf," "personnel performing work on Interprise America's behalf," and similar terms include both natural persons and firms and ventures of every type, including, but not limited to, corporations, partnerships, limited liability companies, sole proprietorships, and joint ventures. The terms "person acting on Interprise America's behalf," "personnel performing work on Interprise America's behalf," and similar terms specifically include, but are not limited to, Interprise America, its officers, directors, employees, agents, representatives, attorneys, contractors, subcontractors, and other persons or entities performing services at the request of or as directed by Interprise America and their respective officers, directors, employees, agents, and representatives.
- 3.1.23 Person acting on BellSouth's behalf. The terms "person acting on BellSouth's behalf," "personnel performing work on BellSouth's behalf," and similar terms include both natural persons and firms and ventures of every type, including but not limited to corporations, partnerships, limited liability companies, sole proprietorships, and joint ventures. The terms "person acting on BellSouth's behalf," "personnel performing work on BellSouth's behalf," and similar terms specifically include, but are not limited to, BellSouth, its officers, directors, employees, agents, representatives, attorneys, contractors, subcontractors, and other persons or entities performing services at the request or on behalf of BellSouth and their respective officers, directors, employees, agents, and representatives.
- 3.1.24 Pole. The term "pole" refers to both utility poles and anchors but only to those utility poles and anchors owned or controlled by BellSouth, and

does not include utility poles or anchors with respect to which BellSouth has no legal authority to permit attachments by other persons or entities.

- 3.1.25 Pole Attachment Act. The terms "Pole Attachment Act" and "Pole Attachment Act of 1978" refer to those provisions of the Communications Act of 1934, as amended, now codified as 47 U.S.C. § 224.
- 3.1.26 Prelicense survey. The term "prelicense survey" refers to all work and activities performed or to be performed to determine whether there is adequate capacity on a pole or in a conduit or conduit system (including manholes and handholes) to accommodate Interprise America's facilities and to determine what make-ready work, if any, is required to prepare the pole, conduit or conduit system to accommodate Interprise America's facilities.
- 3.1.27 Right of Way (ROW). The term "right of way" refers to the right to use the land or other property of another party to place poles, conduits, cables, other structures and equipment, or to provide passage to access such structures and equipment. A Right of Way may run under, on, or above public or private property (including air space above public or private property) and may include the right to use discrete space in buildings, building complexes, or other locations.
- 3.1.28 Sheath. The term "sheath" refers to a single outer covering containing communications wires, fibers, or other communications media.
- 3.1.29 Spare Capacity. The term "spare capacity" refers to any pole attachment space, conduit, duct or inner-duct not currently assigned or subject to a pending application for attachment/occupancy. Spare capacity does not include an inner-duct (not to exceed one inner-duct per party) reserved by BellSouth, Interprise America, or a third party for maintenance, repair, or emergency restoration.
- 3.1.30 State. When capitalized, the term "State" (as used in terms such as "this State") refers to the State of Kentucky.
- 3.1.31 Third Party. The terms "third party" and "third parties" refer to persons and entities other than Interprise America and BellSouth. Use of the term "third party" does not signify that any such person or entity is a party to this Agreement or has any contractual rights hereunder.

3.2 **[RESERVED FOR FUTURE USE]**

3.3 **DELETED**

3.4 **SCOPE OF AGREEMENT**

3.4.1 Scope of Agreement. BellSouth shall provide Interprise America with equal and nondiscriminatory access to pole space, conduits, ducts, and rights-of-way on terms and conditions equal to those provided by BellSouth to itself or to any other telecommunications service provider. Further, BellSouth shall not withhold or delay assignment of such facilities to Interprise America because of the potential or forecasted needs of itself or other parties.

3.4.2 Attachments and Occupancies Authorized by this Section. BellSouth shall issue one or more licenses to Interprise America authorizing Interprise America to attach facilities to BellSouth's owned or controlled poles and to place facilities within BellSouth's owned or controlled conduits, ducts or rights-of-way under the terms and conditions set forth in this Section and the Telecommunications Act of 1996.

3.4.2.1 Unless otherwise provided herein, authority to attach facilities to BellSouth's owned or controlled poles, to place facilities within BellSouth's owned or controlled conduits, ducts or rights-of-way shall be granted only in individual licenses granted under this Section and the placement or use of such facilities shall be determined in accordance with such licenses and procedures established in this Section.

3.4.2.2 Interprise America agrees that its attachment of facilities to BellSouth's owned or controlled poles, occupancy of BellSouth's owned or controlled conduits, ducts or rights-of-way shall take place pursuant to the licensing procedures set forth herein, and BellSouth agrees that it shall not unreasonably withhold or delay issuance of such licenses.

3.4.3 Licenses. Subject to the terms and conditions set forth in this Section, BellSouth shall issue to Interprise America one or more licenses authorizing Interprise America to place or attach facilities in or to specified poles, conduits, ducts or rights-of-way of BellSouth located within this state. Nothing contained in this Section shall require BellSouth to issue any license to Interprise America with respect to any specific conduit or duct space if, in the engineering judgment of BellSouth, the conduit or duct space requested is necessary to meet BellSouth's present needs, or is licensed by BellSouth to another licensee.

3.4.4 Access and Use of Rights-of-Way. BellSouth acknowledges that it is required by the Telecommunications Act of 1996 to afford Interprise America access to and use of all associated rights-of-way to any sites where BellSouth's owned or controlled poles, manholes, conduits, ducts or

other parts of BellSouth's owned or controlled conduit systems are located.

- 3.4.4.1 BellSouth shall provide Interprise America with access to and use of such rights-of-way to the same extent and for the same purposes that BellSouth may access or use such rights-of-way, including but not limited to access for ingress, egress or other access and to construct, utilize, maintain, modify, and remove facilities for which pole attachment, conduit occupancy, or ROW use licenses have been issued, provided that any agreement with a third party under which BellSouth holds such rights expressly or impliedly grants BellSouth the right to provide such rights to others.
- 3.4.4.2 Where BellSouth notifies Interprise America that BellSouth's agreement with a third party does not expressly or impliedly grant BellSouth the ability to provide such access and use rights to others, upon Interprise America's request, BellSouth will use its best efforts to obtain the owner's consent and to otherwise secure such rights for Interprise America. Interprise America agrees to reimburse BellSouth for the reasonable and demonstrable costs incurred by BellSouth in obtaining such rights for Interprise America.
- 3.4.4.3 In cases where a third party agreement does not grant BellSouth the right to provide access and use rights to others as contemplated in 3.4.4.1 and BellSouth, despite its best efforts, is unable to secure such access and use rights for Interprise America in accordance with 3.4.4.2, or, in the case where Interprise America elects not to invoke its rights under 3.4.4.1 or 3.4.4.2, Interprise America shall be responsible for obtaining such permission to access and use such rights-of-way. BellSouth shall cooperate with Interprise America in obtaining such permission and shall not prevent or delay any third party assignment of ROWs to Interprise America.
- 3.4.4.4 Where BellSouth has any ownership or rights-of-way to buildings or building complexes, or within buildings or building complexes, BellSouth shall offer to Interprise America through a license or other agreement:
 - 3.4.4.4.1 The right to use any available space owned or controlled by BellSouth in the building or building complex to install Interprise America equipment and facilities; and
 - 3.4.4.4.2 Ingress and egress to such space.
- 3.4.5 Except to the extent necessary to meet the requirements of the Telecommunications Act of 1996, neither this Section nor any license granted hereunder shall constitute a conveyance or assignment of any of either party's rights to use any public or private rights-of-way, and nothing

contained in this Section or in any license granted hereunder shall be construed as conferring on one party any right to interfere with the other party's access to any such public or private rights-of-way.

- 3.4.6 No Effect on BellSouth's Right to Convey Property. Nothing contained in this Section or in any license issued hereunder shall in any way affect the right of BellSouth to convey to any other person or entity any interest in real or personal property, including any poles, conduit or ducts to or in which Interprise America has attached or placed facilities pursuant to licenses issued under this Section provided however that BellSouth shall give Interprise America reasonable advance written notice of such intent to convey.
- 3.4.7 No Effect on BellSouth's Rights to Manage its Own Facilities. This Section shall not be construed as limiting or interfering with BellSouth's rights set forth below, except to the extent expressly provided by the provisions of this Section or licenses issued hereunder or by the Telecommunications Act of 1996 or other applicable laws, rules or regulations:
- 3.4.7.1 To locate, relocate, move, replace, modify, maintain, and operate BellSouth's own facilities within BellSouth's conduits, ducts or rights-of-way or any of BellSouth's facilities attached to BellSouth's poles at any time and in any reasonable manner which BellSouth deems appropriate to serve its customers, avail itself of new business opportunities, or otherwise meet its business needs; or
- 3.4.7.2 To enter into new agreements or arrangements with other persons or entities permitting them to attach or place their facilities to or in BellSouth's poles, conduits or ducts; provided, however, that such relocations, moves, replacements, modifications, maintenance and operations or new agreements or arrangements shall not substantially interfere with Interprise America's pole attachment, conduit occupancy or ROW use, rights provided by licenses Issued pursuant to this Section .
- 3.4.8 No Effect on Interprise America's Rights to Manage its Own Facilities. This Section shall not be construed as limiting or interfering with Interprise America's rights set forth below, except to the extent expressly provided by the provisions of this Section or licenses issued hereunder or by the Telecommunications Act of 1996 or other applicable laws, rules or regulations:
- 3.4.8.1 To locate, relocate, move, replace, modify, maintain, and operate its own facilities within BellSouth's conduits, ducts or rights-of-way or its facilities attached to BellSouth's poles at any time and in any reasonable manner which Interprise America deems appropriate to serve its customers, avail

itself of new business opportunities, or otherwise meet its business needs;
or

- 3.4.8.2 To enter into new agreements or arrangements with other persons or entities permitting Interprise America to attach or place its facilities to or in such other persons' or entities' poles, conduits or ducts, or rights-of-way; provided, however, that such relocations, moves, replacements, modifications, maintenance and operations or new agreements or arrangements shall not conflict with Interprise America's obligations under licenses issued pursuant to this Section.
- 3.4.9 No Right to Interfere with Facilities of Others. The provisions of this Section or any license issued hereunder shall not be construed as authorizing either party to this Section to rearrange or interfere in any way with any of the other party's facilities, with the facilities of other persons or entities, or with the use of or access to such facilities by such other party or such other persons or entities, except to the extent expressly provided by the provisions of this Section or any license issued hereunder or by the Telecommunications Act of 1996 or other applicable laws, rules or regulations.
- 3.4.9.1 **DELETED**
- 3.4.9.2 Interprise America acknowledges that the facilities of persons or entities other than BellSouth and Interprise America may be attached to or occupy BellSouth's poles, conduits, ducts and rights-of-way.
- 3.4.9.3 BellSouth shall not attach, or give permission to any third parties to attach facilities to, existing Interprise America facilities without Interprise America's prior written consent. If BellSouth becomes aware of any such unauthorized attachment to Interprise America facilities, BellSouth shall use its best efforts to rectify the situation as soon as practicable.
- 3.4.10 **DELETED**
- 3.4.10.1 With respect to facilities occupied by Interprise America or the subject of an application for attachment by Interprise America, BellSouth will give to Interprise America 60 days written notice for conduit extensions or reinforcements, 60 days written notice for pole line extensions, 60 days written notice for pole replacements, and 60 days written notice of BellSouth's intention to construct, reconstruct, expand or place such facilities or of BellSouth's intention not to maintain or use any existing facility and, in the case of an existing facility which BellSouth elects not to maintain or use, BellSouth will grant to Interprise America a right to maintain and use such facility. If an emergency or provisions of an applicable joint use agreement require BellSouth to construct, reconstruct, expand or replace poles, conduits or ducts occupied by Interprise America

or the subject of an application for attachment by Interprise America, BellSouth will notify Interprise America as soon as reasonably practicable of such proposed construction, reconstruction, expansion or replacement to enable Interprise America, if it so desires, to request that a pole, conduit or duct of greater height or capacity be utilized to accommodate an anticipated facility need of Interprise America.

- 3.4.10.2 At Interprise America's request and at its expense, BellSouth shall remove any retired cable from conduit systems to accommodate Interprise America's facilities and to allow for the efficient use of conduit space within a reasonable period of time. If the parties are unable to agree to such removal arrangements, the matter may be resolved pursuant to Section 15 of the General Terms and Conditions of this Agreement.
- 3.4.10.3 BellSouth will allow Interprise America for itself, or in conjunction with other telecommunications carriers, to reserve spares and space for maintenance and emergency purposes in the same manner and for the same period as it reserves such spares and space for itself.
- 3.4.11 Assignment of Space. Assignment of space on poles, in conduits or ducts and within ROWs will be made pursuant to licenses granted by BellSouth on an equal basis to BellSouth, Interprise America and other telecommunication service providers.

3.5 **REQUIREMENTS AND SPECIFICATIONS**

- 3.5.1 Published Standards Incorporated in this Section by Reference. Interprise America agrees that its facilities shall be placed, constructed, maintained, repaired, and removed in accordance with current (as of the date when such work is performed) editions of the following publications, each of which is incorporated by reference as part of this Section :
 - 3.5.1.1 The Blue Book Manual of Construction Procedures, Special Report SR-TAP-001421, published by Bell Communications Research, Inc. ("Bellcore"), and sometimes referred to as the "Blue Book";
 - 3.5.1.2 The National Electrical Code (NEC); and
 - 3.5.1.3 The National Electrical Safety Code (NESC).
- 3.5.2 Changes in Published Standards. Interprise America agrees to rearrange its facilities in accordance with changes in the standards published in the publications specified in Article 5.01 of this Attachment if required by law to do so or upon the mutual agreement of the parties.
- 3.5.3 Additional Electrical Design Specifications. Interprise America agrees that, in addition to specifications and requirements referred to in Articles 3.5.1-

3.5.2 above, Interprise America's facilities placed in BellSouth's conduit system shall meet all of the following electrical design specifications:

- 3.5.3.1 No facility shall be placed in BellSouth's conduit system in violation of FCC regulations.
- 3.5.3.2 Interprise America's facilities placed in BellSouth's conduit system shall not be designed to use the earth as the sole conductor for any part of Interprise America's circuits.
- 3.5.3.3 Interprise America's facilities carrying more than 50 volts AC (rms) to ground or 135 volts DC to ground shall be enclosed in an effectively grounded sheath or shield.
- 3.5.3.4 No coaxial cable of Interprise America shall occupy a conduit system containing BellSouth's cable unless such cable of Interprise America meets the voltage limitations of Article 820 of the National Electrical Code.
- 3.5.3.5 Interprise America's coaxial cable may carry continuous DC voltages up to 1800 volts to ground where the conductor current will not exceed one-half amperes and where such cable has two separate grounded metal sheaths or shields and a suitable insulating jacket over the outer sheath or shield. The power supply shall be so designed and maintained that the total current carried over the outer sheath shall not exceed 200 micro amperes under normal conditions. Conditions which would increase the current over this level shall be cleared promptly.
- 3.5.3.6 Neither party shall circumvent the other party's corrosion mitigation measures. Each party's new facilities shall be compatible with the other party's facilities so as not to damage any facilities of the other party by corrosion or other chemical reaction.
- 3.5.4 Additional Physical Design Specifications. Interprise America's facilities placed in BellSouth's conduit system must meet all of the following physical design specifications:
 - 3.5.4.1 Cables bound or wrapped with cloth or having any kind of fibrous coverings or impregnated with an adhesive material shall not be placed in BellSouth's conduit or ducts.
 - 3.5.4.2 The integrity of BellSouth's conduit system and overall safety of BellSouth's personnel and other personnel working in BellSouth's conduit system requires that "dielectric cable" be required when Interprise America's cable facility utilizes an alternative duct or route that is shared in the same trench by any current carrying facility of a power utility.
 - 3.5.4.3 New construction splices in Interprise America's fiber optic and twisted pair cables shall be located in manholes, pull boxes or handholes.

- 3.5.5 Additional Specifications Applicable to Connections. The following specifications apply to connections of Interprise America's conduit to BellSouth's conduit system:
- 3.5.5.1 Interprise America will be permitted to connect its conduit or duct only at the point of a BellSouth manhole. No attachment will be made by entering or breaking into conduit between manholes. All necessary work to install Interprise America facilities will be performed by Interprise America or its contractor at Interprise America's expense. In no event shall Interprise America or its contractor "core bore" or make any other modification to BellSouth manhole(s) without the prior written approval of BellSouth, which approval will not be unreasonably delayed or withheld.
- 3.5.5.2 BellSouth may monitor, at Interprise America's expense, the entrance and exit of Interprise America's facilities into BellSouth's manholes and the placement of Interprise America's facilities in BellSouth's manholes.
- 3.5.5.3 If Interprise America constructs or utilizes a duct connected to BellSouth's manhole, the duct and all connections between that duct and BellSouth's manhole shall be sealed, to the extent practicable, to prevent the entry of gases or liquids into BellSouth's conduit system. If Interprise America's duct enters a building, it shall also be sealed where it enters the building and at all other locations necessary to prevent the entry of gases and liquids from the building into BellSouth's conduit system.
- 3.5.6 Requirements Relating to Personnel, Equipment, Material, and Construction Procedures Generally. Duct clearing, rodding or modifications required to grant Interprise America access to BellSouth's conduit systems may be performed by BellSouth at Interprise America's expense at charges which represent BellSouth's actual costs. Alternatively (at Interprise America's option) such work may be performed by a contractor who demonstrates compliance with BellSouth certification requirements, which certification requirements shall be consistent with F.C.C. rules. The parties acknowledge that Interprise America, its contractors, and other persons acting on Interprise America's behalf will perform work for Interprise America (e.g., splicing Interprise America's facilities) within BellSouth's conduit system. Interprise America represents and warrants that neither Interprise America nor any person acting on Interprise America's behalf shall permit any person to climb or work on any of BellSouth's poles or to enter BellSouth's manholes or work within BellSouth's conduit system unless such person has the training, skill, and experience required to recognize potentially dangerous conditions relating to pole or the conduit systems and to perform the work safely.
- 3.5.6.1 Interprise America's facilities within BellSouth's conduit system shall be constructed, placed, rearranged, modified, and removed upon receipt of license specified in 3.7.1. However, no such license will be required for

the , inspection, maintenance, repair or non-physical modifications of Interprise America's facilities.

- 3.5.6.2 "Rodding" or clearing of ducts in BellSouth's conduit system shall be done only when specific authorization for such work has been obtained in advance from BellSouth, which authorization shall not be unreasonably delayed or withheld by BellSouth. The parties agree that such rodding or clearing shall be performed according to existing industry standards and practices. Interprise America may contract with BellSouth for performance of such work or (at Interprise America's option) with a contractor who demonstrates compliance with BellSouth certification requirements.
- 3.5.6.3 Personnel performing work on BellSouth's or Interprise America's behalf in BellSouth's conduit system shall not climb on, step on, or otherwise disturb the other party's or any third party's cables, air pipes, equipment, or other facilities located in any manhole or other part of BellSouth's conduit system.
- 3.5.6.4 Personnel performing work on BellSouth's or Interprise America's behalf within BellSouth's conduit system (including any manhole) shall, upon completing their work, make reasonable efforts to remove all tools, unused materials, wire clippings, cable sheathing and other materials brought by them to the work site.
- 3.5.6.5 All of Interprise America's facilities shall be firmly secured and supported in accordance with Bellcore and industry standards.
- 3.5.6.6 Interprise America's facilities shall be plainly identified with Interprise America's name in each manhole with a firmly affixed permanent tag that meets standards set by BellSouth for its own facilities.
- 3.5.6.7 Manhole pumping and purging required in order to allow Interprise America's work operations to proceed shall be performed by Interprise America or its contractor in compliance with BellSouth Practice Sec. 620-145-011BT, "Manhole Contaminants, Water, Sediment or Debris Removal and Reporting Procedures," and any amendments, revisions or supplements thereto and in compliance with all regulations and standards established by the United States Environmental Protection Agency and by any applicable state or local environmental regulators.
- 3.5.6.8 Planks or other types of platforms shall not be installed using cables, pipes or other equipment as a means of support. Platforms shall be supported only by cable racks.
- 3.5.6.9 Any leak detection liquid or device used by Interprise America or personnel performing work on Interprise America's facilities within BellSouth's conduit system shall be of a type approved by BellSouth or Bellcore.

- 3.5.6.10 When Interprise America or personnel performing work on Interprise America's behalf are working within or in the vicinity of any part of BellSouth's poles or conduit system which is located within, under, over, or adjacent to streets, highways, alleys or other traveled rights-of-way, Interprise America and all personnel performing work on Interprise America's behalf shall follow procedures which Interprise America deems appropriate for the protection of persons and property. Interprise America shall be responsible, at all times, for determining and implementing the specific steps required to protect persons and property at the site. Interprise America will provide all traffic control and warning devices required to protect pedestrian and vehicular traffic, workers and property from danger. Interprise America has sole responsibility for the safety of all personnel performing work on Interprise America's behalf, for the safety of bystanders, and for insuring that all operations conform to current OSHA regulations and all other governmental rules, ordinances or statutes. BellSouth reserves the right to suspend Interprise America's activities on, in or in the vicinity of BellSouth's poles or conduit system if, in BellSouth's reasonable judgment, any hazardous condition arises due to the activity (including both acts and omissions) of Interprise America or any personnel performing work on Interprise America's behalf, which suspension shall cease when the condition has been rectified.
- 3.5.6.11 Except for protective screens, no temporary cover shall be placed by Interprise America or personnel performing work on Interprise America's behalf over an open manhole unless it is at least four feet above the surface level of the manhole opening.
- 3.5.6.12 Smoking or the use of any open flame is prohibited in BellSouth's manholes, in any other portion of BellSouth's conduit system, or within 10 feet of any open manhole entrance; provided that this provision will not prohibit the use of spark producing tools such as electric drills, fusion splicers, etc.
- 3.5.6.13 Artificial lighting, when required, will be provided by Interprise America. Only explosion-proof lighting fixtures shall be used.
- 3.5.6.14 Neither Interprise America nor personnel performing work on Interprise America's behalf shall allow any combustible gas, vapor, liquid, or material to accumulate in BellSouth's conduit system (including any manhole) during work operations performed within or in the vicinity of BellSouth's conduit system.
- 3.5.6.15 Interprise America will abide by any laws, regulations or ordinances regarding the use of spark producing tools, equipment or devices in BellSouth's manholes, in any other portions of BellSouth's conduit system, or within 10 feet of any open manhole opening. This includes, but is not

limited to, such tools as electric drills and hammers, meggers, breakdown sets, induction sets, and the like.

- 3.5.7 Opening of Manholes. The following requirements apply to the opening of BellSouth's manholes and the authority of BellSouth personnel present when work on Interprise America's behalf is being performed within or in the vicinity of BellSouth's conduit system.
- 3.5.7.1 BellSouth's manholes shall be opened only as permitted by BellSouth's authorized employees or agents, which permission shall not be unreasonably denied or delayed.
- 3.5.7.2 Interprise America shall notify BellSouth forty-eight (48) hours in advance of any routine work operation requiring entry into any of BellSouth's manholes.
- 3.5.7.3 Interprise America shall be responsible for obtaining any necessary authorization from appropriate authorities to open manholes for conduit work operations therein.
- 3.5.7.4 BellSouth's authorized employee or agent shall not direct or control the conduct of Interprise America's work at the work site. The presence of BellSouth's authorized employee or agent at the work site shall not relieve Interprise America or personnel performing work on Interprise America's behalf of their responsibility to conduct all work operations within BellSouth's conduit system in a safe and workmanlike manner.
- 3.5.7.5 Although BellSouth's authorized employee or agent shall not direct or control the conduct of Interprise America's work at the work site, BellSouth's employee or agent shall have the authority to suspend Interprise America's work operations within BellSouth's conduit system if, in the reasonable discretion of such BellSouth employee or agent, it appears that any hazardous conditions arise or any unsafe practices are being followed by Interprise America or personnel performing work on Interprise America's behalf.
- 3.5.8 OSHA Compliance: Notice to BellSouth of Unsafe Conditions. Interprise America agrees that:
- 3.5.8.1 Its facilities shall be constructed, placed, maintained, repaired, and removed in accordance with the Occupational Safety and Health Act (OSHA) and all rules and regulations promulgated thereunder;
- 3.5.8.2 All persons acting on Interprise America's behalf, including but not limited to Interprise America's employees, agents, contractors, and subcontractors shall, when working on or within BellSouth's poles or conduit system, comply with OSHA and all rules and regulations thereunder;

- 3.5.8.3 Interprise America shall establish appropriate procedures and controls to assure compliance with all requirements of this section; and
- 3.5.8.4 Interprise America (and any person acting on Interprise America's behalf) may report unsafe conditions on, in or in the vicinity of BellSouth's poles or conduit system to BellSouth.
- 3.5.9 Compliance with Environmental Laws and Regulations. Interprise America acknowledges that, from time to time, environmental contaminants may enter BellSouth's conduit system and accumulate in manholes or other conduit facilities and that certain conduits (transite) are constructed with asbestos-containing materials. If BellSouth has knowledge of the presence of such contaminants in a conduit for which Interprise America has applied for or holds a license, BellSouth will promptly notify Interprise America of such fact.
- Notwithstanding any of BellSouth's notification requirements in this Agreement, Interprise America acknowledges that some of BellSouth's conduit is fabricated from asbestos-containing materials. Such conduit is generally marked with a designation of "C Fiber Cement Conduit," "Transite," or "Johns-Manville." Until proven otherwise, Interprise America will presume that all conduit not fabricated of plastic, tile, or wood is asbestos-containing and will handle it pursuant to all applicable regulations relating to worker safety and protection of the environment. BellSouth makes no representations to Interprise America or personnel performing work on Interprise America's behalf that BellSouth's conduit system or any specific portions thereof will be free from environmental contaminants at any particular time. The acknowledgments and representations set forth in the two preceding sentences are not intended to relieve BellSouth of any liability which it would otherwise have under applicable law for the presence of environmental contaminants in its conduit facilities. Interprise America agrees to comply with the following provisions relating to compliance with environmental laws and regulations:
- 3.5.9.1 Interprise America's facilities shall be constructed, placed, maintained, repaired, and removed in accordance with all applicable federal, state, and local environmental statutes, ordinances, rules, regulations, and other laws, including but not limited to the Resource Conservation and Recovery Act (42 U.S.C. §§ 9601 et. seq.), the Toxic Substance Control Act (15 U.S.C. §§ 2601-2629), the Clean Water Act (33 U.S.C. §§ 1251 et. seq.), and the Safe Drinking Water Act (42 U.S.C. §§ 300f-300j).
- 3.5.9.2 All persons acting on Interprise America's behalf, including but not limited to Interprise America's employees, agents, contractors, and subcontractors, shall, when working on, within or in the vicinity of BellSouth's poles or conduit system, comply with all applicable federal,

state, and local environmental laws, including but not limited to all environmental statutes, ordinances, rules, and regulations.

- 3.5.9.3 Interprise America shall establish appropriate procedures and controls to assure compliance with all requirements of this section. BellSouth will be afforded a reasonable opportunity to review such procedures and controls and provide comments that will be reasonably considered in advance of their implementation. Review and comment by BellSouth pursuant to this section will be provided in a timely manner.
- 3.5.9.4 Interprise America and all personnel performing work on Interprise America's behalf shall comply with such standards and practices as BellSouth and Interprise America may from time to time mutually agree to adopt to comply with environmental laws and regulations including, without limitation, BellSouth Practice Sec. 620-145-011BT, "Manhole Contaminants, Water, Sediment or Debris Removal and Reporting Procedures". Pursuant to this practice, neither Interprise America nor BellSouth nor personnel performing work on either party's behalf shall discharge water or any other substance from any BellSouth manhole or other conduit facility onto public or private property, including any storm water drainage system, without first testing such water or substance for contaminants in accordance with mutually agreed standards and practices and determining that such discharge would not violate any environmental law, create any environmental risk or hazard, or damage the property of any person. Proper handling and disposal of any waste material from a BellSouth manhole by Interprise America or its contractor shall be the responsibility of Interprise America. No such waste material shall be deposited on BellSouth premises for storage or disposal.
- 3.5.10 Compliance with Other Governmental Requirements. Interprise America agrees that its facilities attached to BellSouth's facilities shall be constructed, placed, maintained, and removed in accordance with the ordinances, rules, and regulations of any governing body having jurisdiction of the subject matter. Interprise America shall comply with all statutes, ordinances, rules, regulations and other laws requiring the marking and lighting of aerial wires, cables and other structures to ensure that such wires, cables and structures are not a hazard to aeronautical navigation. Interprise America shall establish appropriate procedures and controls to assure such compliance by all persons acting on Interprise America's behalf, including but not limited to, Interprise America's employees, agents, contractors, and subcontractors.
- 3.5.11 Differences in Standards or Specifications. To the extent that there may be differences in any applicable standards or specifications referred to in this Article 3.5, the most stringent standard or specification shall apply.

3.5.12 Interprise America Solely Responsible for the Condition of Its Facilities. Interprise America shall be responsible at all times for the condition of its facilities and its compliance with the requirements, specifications, rules, regulations, ordinances, and laws specified in 3.5.1-3.5.11 above. In this regard, BellSouth shall have no duty to Interprise America to inspect or monitor the condition of Interprise America's facilities (including but not limited to splices and other facilities connections) located within BellSouth's conduit and ducts or any attachment of Interprise America's facilities to BellSouth's poles, anchors, anchor/guy strands or other pole facilities. BellSouth may, however, conduct such inspections and audits of its poles and conduit system as BellSouth determines reasonable or necessary. Such inspection and audits shall be conducted at BellSouth's expense with the exception of (1) follow-up inspection to confirm remedial action after an observed Interprise America violation of the requirements of this Agreement; and (2) inspection of Interprise America facilities in compliance with a specific mandate of appropriate governmental authority for which inspections the cost shall be borne by Interprise America. Either party may audit the other party's compliance with the terms of this Section. Observed safety hazards or imminent facility failure conditions of another party shall be reported to the affected party where such party can be readily identified.

3.5.13 Efficient use of Conduit. BellSouth will install inner-ducts to increase duct space in existing conduit as facilities permit. The full compliment of inner-ducts will be installed which can be accommodated under sound engineering principles. The number of inner-ducts which can reasonably be installed will be determined by BellSouth.

3.6 **ADDITIONAL LEGAL REQUIREMENTS**

3.6.1 **DELETED**

3.6.1.1 Licenses granted under this Section authorize Interprise America to place facilities in, or attach facilities to, poles, conduits and ducts owned or controlled by BellSouth but do not affect the rights of landowners to control terms and conditions of access to their property.

3.6.1.2 Interprise America agrees that neither Interprise America nor any persons acting on Interprise America's behalf, including but not limited to Interprise America's employees, agents, contractors, and subcontractors, shall engage in any conduct which damages public or private property in the vicinity of BellSouth's poles or conduit system, interferes in any way with the use or enjoyment of public or private property except as expressly permitted by the owner of such property, or creates a hazard or nuisance on such property (including, but not limited to, a hazard or nuisance resulting from any abandonment or failure to remove Interprise America's facilities or any construction debris from the property, failure to erect

warning signs or barricades as may be necessary to give notice to others of unsafe conditions on the premises while work performed on Interprise America's behalf is in progress, or failure to restore the property to a safe condition after such work has been completed).

- 3.6.2 Required Permits, Certificates and Licenses. Interprise America shall be responsible for obtaining any building permits or certificates from governmental authorities necessary to construct, operate, maintain and remove its facilities on public or private property.
- 3.6.2.1 Interprise America shall not attach or place its facilities to or in BellSouth's poles, conduit or duct located on any property for which it or BellSouth has not first obtained all required authorizations.
- 3.6.2.2 BellSouth shall have the right to request evidence that all appropriate authorizations have been obtained. However, such request shall not delay BellSouth's prelicense survey work.
- 3.6.3 Lawful Purposes. All facilities placed by Interprise America in BellSouth's conduit and ducts or on BellSouth's poles, anchors or anchor/guy strands must serve a lawful purpose and the uses made of Interprise America's facilities must comply with all applicable federal, state, and local laws and with all federal, state, and local regulatory rules, regulations, and requirements. In this regard, Interprise America shall not utilize any facilities occupying or attached to BellSouth's conduits, ducts or poles for the purpose of providing any services which it is not authorized by law to provide or for the purpose of enabling any other person or entity to provide any such services.
- 3.7 **FACILITIES AND LICENSES**
- 3.7.1 Licenses Required. Before placing any facilities in BellSouth's conduits or ducts or attaching any facilities to BellSouth's poles, anchors or anchor/guy strands, Interprise America must first apply for and receive a written license from BellSouth. BellSouth shall not unreasonably deny or delay issuance of any license. The time frames for the issuance of the license shall be established pursuant to section 3.7.5.3.
- 3.7.2 **DELETED**
- 3.7.3 Provision of Records and Information to Interprise America.
- 3.7.3.1 In order to obtain information regarding facilities, Interprise America shall make a written request to BellSouth, identifying with reasonable specificity the geographic area for which facilities are required, the types and quantities of the required facilities and the required in-service date. In response to such request, BellSouth shall provide Interprise America with information regarding the types, quantity and location (which may be

provided by provision of route maps and availability of BellSouth poles, conduit and right-of-way located within the geographic area specified by Interprise America. Provision of information under the terms of this section shall include the right of Interprise America employees or agents to inspect and copy engineering records or drawings which pertain to those facilities within the geographic area identified in Interprise America's request. Such inspection and copying shall be done at a time and place mutually agreed upon by the parties.

3.7.4 **MAKE-READY WORK**

3.7.4.1 If performed by BellSouth, make-ready work to accommodate Interprise America's facilities shall be included in the normal work load schedule of BellSouth with construction responsibilities in the geographic areas where the relevant poles or conduit systems are located and shall not be entitled to priority, advancement, or preference over other work to be performed by BellSouth in the ordinary course of BellSouth's business.

3.7.4.2 If Interprise America desires make-ready work to be performed on an expedited basis and BellSouth agrees to perform the work on such a basis, BellSouth shall recalculate the estimated make-ready charges. If Interprise America accepts BellSouth's offer, Interprise America shall pay such additional charges.

3.7.4.3 All charges for make-ready work performed by BellSouth are payable in advance, with the amount of any such advance payment to be due within sixty (60) days after receipt of an invoice from BellSouth.

3.7.4.4 In lieu of obtaining performance of make-ready work by BellSouth, Interprise America at its option may arrange for the performance of such work by a contractor certified by BellSouth to work on or in its facilities. Certification shall be granted based upon reasonable and customary criteria employed by BellSouth in the selection of its own contract labor. Notwithstanding any other provisions of this Section, Interprise America may not employ a contractor to accomplish make-ready work if BellSouth is likewise precluded from contractor selection under the terms of an applicable joint use agreement.

3.7.4.5 BellSouth will issue a license to Interprise America at the time all make-ready work necessary to Interprise America's attachment or occupancy has been completed.

3.7.5 Application Form and Fees. To apply for a license under this Section, Interprise America shall submit to BellSouth two signed copies of an Application and Conduit Occupancy License form or an Application and Pole Attachment License form. BellSouth will process license applications in the order in which they are received; provided, however, that when

Interprise America has multiple applications on file with BellSouth, Interprise America may designate its desired priority of completion of prelicense surveys and make-ready work with respect to all such applications.

- 3.7.5.1 Each application for a license under this Section shall specify the proposed route of Interprise America's facilities and identify the conduits and ducts or poles and pole facilities along the proposed route in which Interprise America desires to place or attach its facilities, and describe the physical size, weight and jacket material of the cable which Interprise America desires to place in each conduit or duct or the number and type of cables, apparatus enclosures and other facilities which Interprise America desires to attach to each pole.
- 3.7.5.2 Each application for a license under this Section shall be accompanied by a proposed (or estimated) construction schedule containing the information specified below in 3.10.1 of this Attachment, and an indication of whether Interprise America will, at its option, perform its own make-ready work.
- 3.7.5.3 The parties agree to the establishment of a joint task force, consisting of representatives of Interprise America and BellSouth, which will develop all procedures necessary to effectuate the provisions of this Section 3.7. Matters to be addressed by the joint task force include, without limitation, the development of time frames for BellSouth's provision of record information and availability determinations and for the processing of license applications; the establishment of guidelines to address the number of Interprise America applications which may be processed simultaneously by BellSouth; and any other matters necessary to effectuate the provisions of this Section. The parties agree to negotiate in good faith to achieve agreement on all matters presented to the joint task force and to reduce said agreement to writing within sixty (60) calendar days from the Effective Date of this Agreement.
- 3.7.6 **Multiple Cables, Multiple Services, Lashing or Placing Additional Cables, and Replacement of Facilities.** Interprise America may include multiple cables in a single license application and multiple services (e.g., CATV and non-CATV services) may be provided by Interprise America in the same cable sheath. Interprise America's lashing additional cable to existing facilities of Interprise America and placing additional cables in conduits or ducts already occupied by Interprise America's facilities shall be permitted, and no additional fees will be applied; provided, however, that if Interprise America desires to lash additional cable to existing facilities or place additional cables in conduits or ducts which are already occupied, or to replace existing facilities with new facilities substantially different from those described in licenses in effect, Interprise America must apply for and acquire a new license specifically describing the

physical size, weight and jacket material of the cable to be placed in BellSouth's conduits and ducts or the physical size, weight, and jacket type of cables and the size and weight of apparatus enclosures and other facilities to be attached to BellSouth's poles.

3.7.7 **DELETED**

3.7.8 Single Point of Contact. Each party hereby designates the employees named below as their single point of contact for any and all purposes of this Section , including, but not limited to, processing licenses and applications and providing records and information . Each party may at any time designate a new point of contact by giving written notice of such change.

John Chaucer - Specialist
3535 Colonnade Parkway
Room W3D2
Birmingham, Alabama 35243
(205) 977- 2631
Fax (205) 977-7997

Anything to the contrary herein notwithstanding, notification of an emergency condition which poses an immediate threat to life or property or substantially impairs provisioning of BellSouth's service shall be reported to BellSouth by contacting:

John Chaucer - Specialist
3535 Colonnade Parkway
Room W3D2
Birmingham, Alabama 35243
(205) 977- 2631
Fax (205) 977-7997

3.8 **PROCESSING OF APPLICATIONS (INCLUDING PRELICENSE SURVEYS AND FIELD INSPECTIONS)**

3.8.1 Interprise America's Priorities. When Interprise America has multiple applications on file with BellSouth, Interprise America shall designate its desired priority of completion of prelicense surveys and make-ready work with respect to all such applications.

3.8.2 Prelicense Survey. After Interprise America has submitted its written application for a license, a prelicense survey (including a field inspection) will be performed by either party, in the company of a representative of the other party as mutually agreed, to determine whether BellSouth's poles, anchors and anchor/guy strands, or conduit system, in their present

condition, can accommodate Interprise America's facilities, without substantially interfering with the ability of BellSouth or any other authorized person or entity to use or access the pole, anchor or anchor/guy strand or any portion of BellSouth's conduit system or facilities attached to BellSouth's pole or placed within or connected to BellSouth's conduit system. If Interprise America gives its prior written consent in writing, the determination of duct availability may include the "rodding" of ducts at Interprise America's expense.

- 3.8.2.1 The purpose of the prelicense survey is to determine whether Interprise America's proposed attachments to BellSouth's poles or occupancy of BellSouth's conduit and ducts will substantially interfere with use of BellSouth's facilities by BellSouth and others with facilities occupying, connected or attached to BellSouth's pole or conduit system; and to provide information to Interprise America for its determination of whether the pole, anchor, anchor/guy strand, conduit, duct, or right-of-way is suitable for its use.
- 3.8.2.2 Based on information provided by BellSouth, Interprise America shall determine whether BellSouth's pole, anchor, anchor/guy strand, conduit and duct facilities are suitable to meet Interprise America's needs.
- 3.8.2.3 BellSouth may not unreasonably refuse to continue to process an application based on BellSouth's determination that Interprise America's proposed use of BellSouth's facilities will not be in compliance with applicable requirements, specifications, rules, regulations, ordinances, and laws. The parties shall submit the issue for resolution pursuant to the procedures set forth in Section 15 of the General Terms and Conditions of this Agreement. Interprise America shall be responsible for making its own, independent determination that its use of such facilities will be in compliance with such requirements, specifications, rules, regulations, ordinances and laws. Interprise America acknowledges that BellSouth is not explicitly or implicitly warranting to Interprise America that Interprise America's proposed use of BellSouth's facilities will be in compliance with applicable requirements, specifications, rules, regulations, ordinances, and laws.
- 3.8.3 **DELETE**
- 3.8.4 Administrative Processing. The administrative processing portion of the prelicense survey (which includes without limitation processing the application, preparing make-ready work orders, notifying joint users and other persons and entities of work requirements and schedules, coordinating the relocation/rearrangement of BellSouth and/or other licensed facilities) will be performed by BellSouth at Interprise America's expense. Anything to the contrary herein notwithstanding, BellSouth shall

bear no responsibility for the relocation, rearrangement or removal of facilities used for the transmission or distribution of electric power.

3.9 **ISSUANCE OF LICENSES**

3.9.1 Obligation to Issue Licenses. BellSouth shall issue a license to Interprise America pursuant to this Section 3.9. BellSouth and Interprise America acknowledge that each application for a license shall be evaluated on an individual basis. Nothing contained in this section shall be construed as abridging any independent pole attachment rights or conduit or duct access rights which Interprise America may have under the provisions of any applicable federal or state laws or regulations governing access to BellSouth's poles, conduits and ducts, to the extent the same are not inconsistent with the Telecommunications Act of 1996. Each license issued hereunder shall be for an indefinite term, subject to Interprise America's compliance with the provisions applicable to such license and further subject to Interprise America's right to terminate such license at any time for any reason upon at least thirty (30) days' prior written notice.

3.9.2 **DELETED**

3.9.3 Multiple Applications. Interprise America acknowledges that multiple parties including BellSouth may seek to place their facilities in BellSouth's conduit and ducts at or about the same time, that the make-ready work required to prepare BellSouth's facilities to accommodate multiple applicants may differ from the make-ready work required to accommodate a single applicant, that issues relating to the proper apportionment of costs arise in multi-applicant situations that do not arise in single-applicant situations, and that cooperation and negotiations between all applicants and BellSouth may be necessary to resolve disputes involving multiple applications for permission to place facilities in/on the same pole, conduit, duct, or right-of-way.

3.9.3.1 All applications will be processed on a first-come, first served basis.

3.9.4 Agreement to Pay for All Make-Ready Work Completed. Interprise America's submission of written authorization for make-ready work shall also constitute Interprise America's agreement to pay additional cost-based charges, if any, for completed make-ready work as provided in Section 3.7.4.3 of this Attachment; provided, however, to the extent BellSouth is also utilizing the facility and to the extent any repair or modification is used to bring the facilities into compliance with any applicable safety or other governmental requirement, BellSouth will be responsible for its share of the repair or modification cost.

3.9.5 Payments to Others for Expenses Incurred in Transferring or Arranging Their Facilities. Interprise America shall make arrangements with the

owners of other facilities located in or connected to BellSouth's conduit system or attached to BellSouth's poles, anchors or anchor/guy strands regarding reimbursement for any expenses incurred by them in transferring or rearranging their facilities to accommodate the placement or attachment of Interprise America's facilities in or to BellSouth's structures.

3.9.6 **DELETED**

3.9.7 **DELETED**

3.9.8 Make-Ready Work on an Expedited Basis.

3.9.8.1.1 **DELETED**

3.9.8.1.2 **DELETED**

3.9.8.1.3 If Interprise America is willing to authorize BellSouth to perform make-ready work on an expedited basis, and if BellSouth agrees to perform the work on such a basis, BellSouth shall recalculate the estimated make-ready charges. If Interprise America accepts BellSouth's offer, upon completion of the make-ready work Interprise America shall pay such additional charges, if any.

3.9.9 License. When Interprise America's application for a pole attachment or conduit occupancy license is approved, and all required make-ready work completed, BellSouth will execute and return a signed authorization to Interprise America, as appropriate, authorizing Interprise America to attach or place the specified facilities on BellSouth's poles or in BellSouth's conduit or ducts.

3.9.9.1 Each license issued under this Section shall authorize Interprise America to attach to BellSouth's poles or place or maintain in BellSouth's conduit or ducts only those facilities specifically described in the license, and no others.

3.9.9.2 Except as expressly stated to the contrary in individual licenses issued hereunder, each license issued pursuant to this Section shall incorporate all terms and conditions of this Section whether or not such terms or conditions are expressly incorporated by reference on the face of the license itself.

3.10 **CONSTRUCTION OF INTERPRISE AMERICA'S FACILITIES**

3.10.1 Construction Schedule. Interprise America shall submit with Interprise America's license application a proposed or estimated construction schedule. Promptly after the issuance of a license permitting Interprise America to attach facilities to BellSouth's poles or place facilities in

BellSouth's conduit or ducts, Interprise America shall provide BellSouth with an updated construction schedule and shall thereafter keep BellSouth informed of significant anticipated changes in the construction schedule. Construction schedules required by this Section shall include, at a minimum, the following information:

- 3.10.1.1 The name, title, business address, and business telephone number of the manager responsible for construction of the facilities;
 - 3.10.1.2 The names of each contractor and subcontractor which will be involved in the construction activities;
 - 3.10.1.3 The estimated dates when construction will begin and end; and
 - 3.10.1.4 The approximate dates when Interprise America or persons acting on Interprise America's behalf will be performing construction work in connection with the placement of Interprise America's facilities in BellSouth's conduit or ducts.
- 3.10.2 Additional Pre-construction Procedures for Facilities Placed in Conduit System. The following procedures shall apply before Interprise America places facilities in BellSouth's conduit system:
- 3.10.2.1 Interprise America shall give written notice of the type of facilities which are to be placed; and
 - 3.10.2.2 BellSouth shall provide to Interprise America space in manholes for racking and storage of up to fifty (50) feet of cable, provided space is available.
- 3.10.3 **DELETED**
- 3.10.4 BellSouth Not Responsible for Constructing or Placing Facilities. BellSouth shall have no obligation to construct any facilities for Interprise America or to attach Interprise America's facilities to, or place Interprise America's facilities in, BellSouth's poles or conduit system, except as may be necessary to facilitate the interconnection of unbundled network elements or except to the extent expressly provided in this Section, any license issued hereunder, or by the Telecommunications Act of 1996 or any other applicable law.
- 3.10.5 Interprise America Responsible for Constructing, Attaching and Placing Facilities. Except where otherwise mutually agreed by Interprise America and BellSouth, Interprise America shall be responsible for constructing its own facilities and attaching those facilities to, or placing them in BellSouth's poles, conduit or ducts at Interprise America's sole cost and expense. Interprise America shall be solely responsible for paying all persons and entities who provide materials, labor, access to real or

personal property, or other goods or services in connection with the construction and placement of Interprise America's facilities and for directing the activities of all persons acting on Interprise America's behalf while they are physically present on BellSouth's pole, in any part of BellSouth's conduit system or in the vicinity of BellSouth's poles or conduit system.

- 3.10.6 Compliance with Applicable Standards, Health and Safety Requirements, and Other Legal Requirements. Interprise America shall construct its facilities in accordance with the provisions of this Section and all licenses issued hereunder.
- 3.10.6.1 Interprise America shall construct, attach and place its facilities in compliance with all Requirements and Specifications set forth above in 3.5 of this Attachment.
- 3.10.6.2 Interprise America shall satisfy all Legal Requirements set forth above in 3.6 of this Section.
- 3.10.6.3 Interprise America shall not permit any person acting on Interprise America's behalf to perform any work on BellSouth's poles or within BellSouth's conduit system without first verifying, to the extent practicable, on each date when such work is to be performed, that the condition of the pole or conduit system is suitable for the work to be performed. If Interprise America or any person working on Interprise America's behalf determines that the condition of the pole or conduit system is not suitable for the work to be performed, Interprise America shall notify BellSouth of the condition of the pole or conduit system in question and shall not proceed with construction activities until Interprise America is satisfied that the work can be safely performed.
- 3.10.7 Construction Notices. If requested to do so, Interprise America shall provide BellSouth with information to reasonably assure BellSouth that construction has been performed in accordance with all applicable standards and requirements.
- 3.10.8 Points for Attachment. BellSouth shall specify, using the same selection criteria it uses for its own operating company, the point of attachment of each pole or anchor to be occupied by Interprise America's facilities. When the facilities of more than one applicant are involved, BellSouth will attempt, to the extent practicable, to designate the same relative position on each pole or anchor for each applicant's facilities.
- 3.10.9 Manhole and Conduit Break-Outs. Interprise America shall be permitted to add conduit ports to BellSouth manholes when existing conduits do not provide the pathway connectivity needed by Interprise America; provided

the structural integrity of the manhole is maintained, and sound engineering judgment is employed.

- 3.10.10 Interprise America shall have no liability for costs incurred by BellSouth in repair or maintenance of BellSouth-owned facilities, provided that such costs are not attributable, in whole or part, to the presence of Interprise America's facilities in or on the facilities of BellSouth or Interprise America's exercise of any other rights granted pursuant to this Agreement. If there is a dispute as to BellSouth's assessment of costs to Interprise America, BellSouth shall demonstrate to Interprise America how such costs are attributable to the presence of Interprise America's facilities or the exercise of rights Interprise America has under this Agreement. Any unresolved dispute shall be resolved pursuant to Section 15 of the General Terms and Conditions of this Agreement.

3.11 **USE AND ROUTINE MAINTENANCE OF INTERPRISE AMERICA'S FACILITIES**

- 3.11.1 Use of Interprise America's Facilities. Each license granted under this Section authorizes Interprise America to have access to Interprise America's facilities on or in BellSouth's poles, conduits and ducts as needed for the purpose of serving Interprise America's customers, including, but not limited to, powering electronics, monitoring facilities, or transporting signaling.
- 3.11.2 Routine Maintenance of Interprise America's Facilities. Each license granted under this Section authorizes Interprise America to engage in routine maintenance of Interprise America's facilities located on or in BellSouth's poles, conduits, ducts and ROW pursuant to such license. Interprise America shall give reasonable notice to the affected public authority or private landowner as appropriate before commencing the construction or installation of its attachments or making any material alterations thereto. Interprise America shall give reasonable notice to BellSouth before performing any work, whether or not of a routine nature, in BellSouth's conduit system.
- 3.11.3 Interprise America Responsible for Maintenance of Interprise America's Facilities. Interprise America shall maintain its facilities in accordance with the provisions of this Section (including but not limited to all Requirements set forth above in 3.5 of this Section) and all licenses issued hereunder. Interprise America shall be solely responsible for paying all persons and entities who provide materials, labor, access to real or personal property, or other goods or services in connection with the maintenance of Interprise America's facilities and for directing the activities of all persons acting on Interprise America's behalf while they are physically present on BellSouth's poles, within BellSouth's conduit system or in the immediate vicinity of such poles or conduit system.

- 3.11.4 BellSouth Not Responsible for Maintaining Interprise America's Facilities. BellSouth shall have no obligation to maintain any facilities which Interprise America has attached or connected to, or placed in, BellSouth's poles, conduits, ducts or any portion of BellSouth's conduit system, except to the extent expressly provided by the provisions of this Section or any license issued hereunder, or by the Telecommunications Act of 1996 or other applicable laws, rules or regulations.
- 3.11.5 Information Concerning the Maintenance of Interprise America's Facilities. Promptly after the issuance of a license permitting Interprise America to attach facilities to, or place facilities in BellSouth's poles, conduits or ducts, Interprise America shall provide BellSouth with the name, title, business address, and business telephone number of the manager responsible for routine maintenance of Interprise America's facilities, and shall thereafter notify BellSouth of changes to such information. The manager responsible for routine maintenance of Interprise America's facilities shall, on BellSouth's request, identify any contractor, subcontractor, or other person performing maintenance activities on Interprise America's behalf at a specified site and shall, on BellSouth's request, provide such additional documentation relating to the maintenance of Interprise America's facilities as reasonably necessary to demonstrate that Interprise America and all persons acting on Interprise America's behalf are complying with the requirements of this Section and licenses issued hereunder.
- 3.11.6 Identification of Personnel Authorized to Have Access to Interprise America's Facilities. All personnel authorized to have access to Interprise America's facilities shall, while working on BellSouth's poles, in its conduit system or ducts or in the vicinity of such poles, ducts or conduit systems, carry with them suitable identification and shall, upon the request of any BellSouth employee, produce such identification.
- 3.12 **MODIFICATION AND REPLACEMENT OF INTERPRISE AMERICA'S FACILITIES**
- 3.12.1 Notification of Planned Modification or Replacement of Facilities. Interprise America shall, when practicable, notify BellSouth in writing at least 60 days before adding to, relocating, replacing or otherwise modifying its facilities attached to a BellSouth pole, anchor or anchor/guy strand or located in any BellSouth conduit or duct. The notice shall contain sufficient information to enable BellSouth to determine whether the proposed addition, relocation, replacement, or modification is permitted under Interprise America's present license or requires a new or amended license.
- 3.12.2 New or Amended License Required. A new or amended license will be required if the proposed addition, relocation, replacement, or modification:

- 3.12.2.1 Requires that Interprise America use additional space on BellSouth's poles or in its conduits or ducts (including but not limited to any additional ducts, inner ducts, or substantial space in any handhole or manhole) on either a temporary or permanent basis; or
- 3.12.2.2 Results in the size or location of Interprise America's facilities on BellSouth's poles or in its conduit or ducts being appreciably different from those described and authorized in Interprise America's present license (e.g. different duct or size increase causing a need to re-calculate storm loadings, guying, or pole class).
- 3.13 **REARRANGEMENT OF FACILITIES AT THE REQUEST OF ANOTHER**
- 3.13.1 Make-Ready Work at the Request of Interprise America. If, prior to the issuance of a license, Interprise America determines that any pole, anchor, anchor/guy strand, conduit or duct is inadequate to accommodate Interprise America's proposed pole attachment or conduit occupancy or that it will be necessary or desirable for BellSouth or any other person or entity to rearrange existing facilities or structures to accommodate Interprise America, Interprise America shall promptly advise BellSouth of the make-ready work it believes necessary to enable the accommodation of Interprise America's facilities.
- 3.13.1.1 BellSouth shall determine, in the exercise of sound engineering judgment, whether or what make-ready work is necessary or possible. In determining whether make-ready work is necessary or the extent to which make-ready work is necessary BellSouth shall endeavor to minimize its costs to Interprise America. If it is determined that such make-ready work is required, BellSouth shall provide Interprise America with the estimated costs for make-ready work and a Make Ready Due Date. The time frame for providing the estimated costs and due date shall be determined pursuant to 3.7.5.3.
- 3.13.1.2 Interprise America shall be solely responsible for negotiating with persons or entities other than BellSouth for the rearrangement of such persons' or entities' facilities or structures and, except where such rearrangement is for the benefit of BellSouth and/or other licensees as well as Interprise America, shall be solely responsible for paying all charges attributable to the rearrangement of such facilities; provided, however, that if facilities rearrangements require new licenses from BellSouth, BellSouth shall issue such licenses in conjunction with the issuance of the applied-for license to Interprise America.
- 3.13.2 Rearrangement of Interprise America's Facilities at BellSouth's Request. Interprise America acknowledges that, from time to time, it may be necessary or desirable for BellSouth to change out poles, relocate, reconstruct, or modify portions of its conduit system or rearrange facilities

contained therein or connected thereto and that such changes may be necessitated by BellSouth's business needs or authorized application of another entity seeking access to BellSouth's poles or conduit systems. Interprise America agrees that Interprise America will, upon BellSouth's request, and at BellSouth's expense, but at no cost to Interprise America, participate with BellSouth (and other licensees) in the relocation, reconstruction, or modification of BellSouth's conduit system or facilities rearrangement. Interprise America acknowledges that, from time to time, it may be necessary or desirable for BellSouth to change out poles, relocate, reconstruct, or modify portions of its conduit system or rearrange facilities contained therein or connected thereto as a result of an order by a municipality or other governmental authority. Interprise America shall, upon BellSouth's request, participate with BellSouth (and other licensees) in the relocation, reconstruction, or modification of BellSouth's conduit system or facilities rearrangement and pay its proportionate share of any costs of such relocation, reconstruction, or modification that are not reimbursed by such municipality or governmental authority.

- 3.13.2.1 Interprise America shall make all rearrangements of its facilities within such period of time as is jointly deemed reasonable by the parties based on the amount of rearrangements necessary and a desire to minimize chances for service interruption or facility-based service denial to a Interprise America customer.
- 3.13.2.2 If Interprise America fails to make the required rearrangements within the time prescribed in 3.13.2.1 preceding or within such extended periods of time as may be granted by BellSouth in writing, BellSouth may perform such rearrangements with written notice to Interprise America, and Interprise America shall reimburse BellSouth for actual costs and expenses incurred by BellSouth in connection with the rearrangement of Interprise America's facilities; provided, however, that nothing contained in this Section or any license issued hereunder shall be construed as requiring Interprise America to bear any expenses which, under the Telecommunications Act of 1996 or other applicable federal or state laws or regulations, are to be allocated to persons or entities other than Interprise America; and provided further, however, that Interprise America shall have no responsibility for rearrangement costs and expenses relating to rearrangements performed for the purpose of meeting BellSouth's business needs.

3.14 **EMERGENCY REPAIRS AND POLE REPLACEMENTS**

- 3.14.1 Within sixty (60) days after the Effective Date of this Agreement, BellSouth and Interprise America shall mutually agree on a non-discriminatory priority method to access BellSouth poles, conduit and ROW in emergency situations.

- 3.14.2 Interprise America Responsible for Emergency Repairs to its Own Facilities. In general, Interprise America shall be responsible for making emergency repairs to its own facilities and for formulating appropriate plans and practices which will enable it to make such emergency repairs. BellSouth shall be under no obligation to perform any repair or service restoration work of any kind with respect to Interprise America's facilities.
- 3.15 **INSPECTION BY BELL SOUTH OF INTERPRISE AMERICA'S FACILITIES**
- 3.15.1 BellSouth's Right to Make Periodic or Spot Inspections. BellSouth shall have the right to make periodic or spot inspections at any time of any part of Interprise America's facilities attached to BellSouth's poles, anchors or anchor/guy strands or occupying any BellSouth conduit or duct for the limited purpose of determining whether Interprise America's facilities are in compliance with the terms of this Section and licenses hereunder; provided that such inspections must be non-invasive (e.g., no splice cases may be opened).
- 3.15.1.1 BellSouth will give Interprise America advance written notice of such inspections, and Interprise America shall have the right to have a representative attend such inspections, except in those instances where safety considerations justify the need for such inspection without the delay of waiting until written notice has been forwarded to Interprise America.
- 3.15.1.2 Such inspections shall be conducted at BellSouth's expense; provided, however, that Interprise America shall bear the cost of inspections as delineated in 3.5.12.
- 3.15.2 **DELETED**
- 3.15.3 No Duty to Interprise America. Neither the act of inspection by BellSouth of Interprise America's facilities nor any failure to inspect such facilities shall operate to impose on BellSouth any liability of any kind whatsoever or to relieve Interprise America of any responsibility, obligations or liability under this Section or otherwise existing.
- 3.16 **NOTICE OF NONCOMPLIANCE**
- 3.16.1 Notice of Noncompliance. If, at any time, BellSouth determines that Interprise America's facilities or any part thereof have not been placed or maintained or are not being used in accordance with the requirements of this Attachment 3, BellSouth may send written notice to Interprise America specifying the alleged noncompliance. Interprise America agrees to acknowledge receipt of the notice as soon as practicable. If Interprise America does not dispute BellSouth's assertion that such facilities are not in compliance, Interprise America agrees to provide BellSouth with a schedule for bringing such facilities into compliance, to bring the facilities

into compliance within a reasonable time, and to notify BellSouth in writing when the facilities have been brought into compliance.

- 3.16.2 Disputes over Alleged Noncompliance. If Interprise America disputes BellSouth's assertion that Interprise America's facilities are not in compliance, Interprise America shall notify BellSouth in writing of the basis for Interprise America's assertion that its facilities are in compliance.
- 3.16.3 Failure to Bring Facilities into Compliance. If Interprise America has not brought the facilities into compliance within a reasonable time or provided BellSouth with proof sufficient to persuade BellSouth that BellSouth erred in asserting that the facilities were not in compliance, and if BellSouth determines in good faith that the alleged noncompliance causes or is likely to cause material damage to BellSouth's facilities or those of other users, BellSouth may, at its option and Interprise America's expense, take such non-service affecting steps as may be required to bring Interprise America's facilities into compliance, including but not limited to correcting any conditions which do not meet the specifications of 3.5 of this Section .
- 3.16.4 Correction of Conditions by BellSouth. If BellSouth elects to bring Interprise America's facilities into compliance as provided by 3.16.3 of this Section , the provisions of this Section shall apply.
- 3.16.4.1 BellSouth will, whenever practicable, notify Interprise America in writing before performing such work. The written notice shall describe the nature of the work to be performed and BellSouth's schedule for performing the work.
- 3.16.4.2 If Interprise America's facilities have become detached or partially detached from supporting racks or wall supports located within a BellSouth manhole, BellSouth may, at Interprise America's expense, reattach them but shall not be obligated to do so. If BellSouth does not reattach Interprise America's facilities, BellSouth shall endeavor to arrange with Interprise America for the reattachment of any facilities affected.
- 3.16.4.3 BellSouth shall, as soon as practicable after performing the work, advise Interprise America in writing of the work performed or action taken. Upon receiving such notice, Interprise America shall inspect the facilities and take such steps as Interprise America may deem necessary to insure that the facilities meet Interprise America's performance requirements.
- 3.16.5 Interprise America to Bear Expenses. Interprise America shall bear all expenses arising out of or in connection with any work performed to bring Interprise America's facilities into compliance with this Section; provided, however that nothing contained in this Section or any license issued hereunder shall be construed as requiring Interprise America to bear any expenses which, under applicable federal or state laws or regulations,

must be borne by persons or entities other than Interprise America. Disputes between the parties concerning charges by BellSouth to Interprise America pursuant to 3.16.3 shall be resolved in accordance with the procedures set forth in Section 15 of the General Terms and Conditions of this Agreement.

3.17 **UNAUTHORIZED OCCUPANCY OR UTILIZATION OF BELL SOUTH'S FACILITIES**

3.17.1 Licensing or Removal of Unauthorized Attachments. If any of Interprise America's attachments shall be found attached to pole(s) or occupying conduit systems for which no license is outstanding, BellSouth, without prejudice to its other rights or remedies under this Agreement, including termination of licenses, may impose a charge and require Interprise America to submit in writing, within thirty (30) days after receipt of written notification from BellSouth of the unauthorized attachment or conduit occupancy, a pole attachment or conduit occupancy license application. If such application is not received by BellSouth within the specified time period, Interprise America may be required at BellSouth's option to remove its unauthorized attachment or occupancy within sixty (60) days of the final date for submitting the required application, or BellSouth may at BellSouth's option remove Interprise America's facilities without liability, and the expense of such removal shall be borne by Interprise America. Charges for any such unauthorized occupancy shall be equal to the applicable license fees and charges which would have been payable from and after the date such facilities were first placed on BellSouth's poles or in BellSouth's conduit system, if Interprise America provides reasonable documentation of such placement. If Interprise America is unable to provide such reasonable documentation the matter shall be resolved pursuant to the procedures set forth in Section 15 of the General Terms and Conditions of this Agreement. If BellSouth prevails, then Interprise America will pay two years worth of the applicable charges.

3.17.2 **DELETED**

3.17.2.1 **DELETED**

3.17.2.2 **DELETED**

3.17.2.3 Nothing contained in the Agreement or any license issued hereunder shall be construed as requiring Interprise America to bear any expenses which, under applicable federal or state laws or regulations, must be borne by persons or entities other than Interprise America.

3.17.3 Prompt Payment of Applicable Fees and Charges. Fees and charges for pole attachments and conduit system occupancies, as specified herein and as modified from time to time, shall be due and payable immediately

whether or not Interprise America is permitted to continue the pole attachment or conduit occupancy.

- 3.17.4 No Implied Waiver or Ratification of Unauthorized Use. No act or failure to act by BellSouth with regard to said unlicensed use shall be deemed as a ratification of the unlicensed use; and if any license should be subsequently issued, said license shall not operate retroactively or constitute a waiver by BellSouth of any of its rights or privileges under this Agreement or otherwise; provided, however, that Interprise America shall be subject to all liabilities, obligations and responsibilities of this Agreement in regard to said unauthorized use from its inception.

3.18 **REMOVAL OF INTERPRISE AMERICA'S FACILITIES**

- 3.18.1 Pole Attachments. Interprise America, at its expense, will remove its attachments from any of BellSouth's poles within thirty (30) days after termination of the license covering such attachments, unless another time period is mutually agreed upon by the parties. If Interprise America fails to remove its attachments within such thirty (30) day period, BellSouth shall have the right to remove such attachments at Interprise America's expense and without any liability on the part of BellSouth for damage or injury to Interprise America's attachments unless caused by the negligence or intentional misconduct of BellSouth. Notwithstanding the foregoing, Interprise America shall have no obligation to remove its attachment, where it has previously borne the cost of removing unused or abandoned attachments (whether placed by BST or a third party), and such removal was necessary to prepare the poles for occupancy by Interprise America.
- 3.18.2 Conduit Occupancy. Unless another time period is mutually agreed upon by the parties, Interprise America, at its expense, will remove its communications facilities from a conduit system within sixty (60) days after:
- 3.18.2.1 Termination of the license covering such conduit occupancy; or
- 3.18.2.2 The date Interprise America replaces its existing facilities in one duct with substitute facilities in another duct.
- 3.18.2.3 Notwithstanding the foregoing, Interprise America shall have no obligation to remove its facilities where it has previously borne the cost of removing unused or abandoned facilities (whether placed by BellSouth or a third party), and such removal was necessary to prepare the conduit systems for occupancy by Interprise America.
- 3.18.3 If Interprise America fails to remove its facilities within the specified period, BellSouth shall have the right to remove such facilities at Interprise

America's expense and without any liability on the part of BellSouth for damage or injury to such facilities unless caused by the negligence or intentional misconduct of BellSouth.

3.18.4 Continuing Responsibility for Fees and Charges. Interprise America shall remain liable for and pay to BellSouth all fees and charges pursuant to provisions of this Agreement until all of Interprise America's facilities are physically removed from BellSouth's poles or conduit system.

3.19 **FEES, CHARGES, AND BILLING**

3.19.1 **DELETED**

3.19.2 **DELETED**

3.19.3 **DELETED**

3.19.4 **DELETED**

3.19.5 License Charges. License charges commence on the first day of the calendar month following the date a license is issued. Such charges cease as of the final day of the calendar month preceding the month in which the attachment or occupancy is physically removed or the utilization is discontinued. A one-month minimum charge is applicable to all licenses.

3.19.6 Notice of Rate and Computation of Charges. On or about November 1 of each year, BellSouth will notify Interprise America by certified mail, return receipt requested, of the rental rate and pole transfer rate to be applied in the subsequent calendar year. The letter of notification shall be incorporated in, and governed by, the terms and conditions of this Agreement. Attachment and occupancy rates shall be applied to the number of pole(s) and duct feet of conduit for which licenses have been issued before December 1 of each calendar year. Charges for attachment(s) and occupancy which commenced during the preceding twelve (12) month period will be prorated accordingly.

3.20 **ADVANCE PAYMENT AND IMPUTATION**

3.20.1 **DELETED**

3.20.2 Attachment and Occupancy Fees. Fees for pole attachment and conduit occupancy shall be based on the facilities for which licenses have been issued as of the date of billing by BellSouth, shall be computed as set forth in Part IV of the General Terms and Conditions section of this Agreement and shall be payable annually.

3.20.2.1 **DELETED**

3.20.2.2 Charges associated with newly licensed attachments or occupancies and other attachments or occupancies of less than the entire annual billing period shall be prorated.

3.20.2.3 Charges shall be prorated retroactively in the event of the removal of Interprise America's facilities.

3.20.3 **DELETED**

3.20.4 The amount of any advance payment required under this Article 3.20 shall be due within sixty (60) days after receipt of an invoice from BellSouth.

3.20.5 Imputation. BellSouth shall impute to its costs of providing telecommunications services (and charge any affiliate, subsidiary, or associate company engaged in the provision of such services) an equal amount to the charges set forth in this Section for all of the conduits, ducts, and poles it occupies and uses.

3.21 **DELETED**

3.22 **ASSURANCE OF PAYMENT**

3.22.1 In the event Interprise America fails to demonstrate credit worthiness, Interprise America may be required to furnish a bond, letter of credit or other evidence of financial security having a minimum face amount of \$10,000.00 per state or \$50,000.00 per region. Such bond, letter of credit or other security shall be in a form satisfactory to BellSouth and may be increased from time to time as reasonably required by BellSouth to guarantee the performance of all obligations of Interprise America hereunder. The amount of the bond, letter of credit or other security shall not operate as a limitation upon the obligations of Interprise America hereunder.

Exhibit I

ADMINISTRATIVE FORMS AND NOTICES

This Exhibit I lists the types of administrative forms to be utilized in connection with this Section.

LIST OF ADMINISTRATIVE FORMS

Authorization for Make-Ready Work
Application and Conduit Occupancy License
Conduit System Diagram
Cable to Occupy Conduit
Equipment Housings to be Placed in manholes
Notification of Surrender or Modification of Conduit
Occupancy License by Licenses
Notifications of Unauthorized Attachments by Applicant
Application and Pole Attachment License
Pole, Anchor and Guy Strand Details
Application and Unused Transmission Media License
Application Survey Data
Notification of Surrender or Modification of Pole
Attachment License by Licenses

TABLE OF CONTENTS

	<u>Page</u>
PROVISIONING AND ORDERING	
1. Network Deployment	1
2. General Provisioning Requirements	1
3. Specific Provisioning Process Requirements.....	2
4. General Ordering Requirements.....	4
5. Ordering Interfaces	5
6. BellSouth Provision of Information.....	5
7. Order Format and Data Elements for Individual Network Elements.....	6
8. DELETE	6
9. Performance Requirements	6

Provisioning and Ordering

1. Network Deployment

- 1.1 BellSouth shall deploy and maintain network facilities in all its serving areas in every LATA from and after the Effective Date of this Agreement as necessary to provide on a timely basis each of the Elements, as defined below, that BellSouth is required to offer to Interprise America pursuant to this Agreement.
- 1.2 Throughout the term of this Agreement, the quality of the technology, equipment, facilities, processes, and techniques (including, without limitation, such new architecture, equipment, facilities, and interfaces as BellSouth may deploy) that BellSouth provides to Interprise America under this Agreement shall be in accordance with standards or other measurements that are at least equal to the highest level that BellSouth provides or is required to provide by law and its own internal procedures.

2. General Provisioning Requirements

2.1 DELETED

- 2.2 Multiple individual Elements may be ordered by Interprise America from BellSouth on a single order (either LSR or ASR) encompassing all elements or combinations of elements. Until Electronic Interfaces are in place to meet these requirements, Interprise America and BellSouth will use best efforts to develop an interim process to meet these requirements.

2.3 DELETED

- 2.4 BellSouth shall provide provisioning services to Interprise America equal to the provisioning services BellSouth provides to itself during normal business hours. If Interprise America requests that BellSouth perform provisioning services at times or on days other than as set forth in the preceding sentence, BellSouth and Interprise America shall mutually negotiate such provisioning including time interval and cost.

- 2.5 To ensure that Interprise America's Customers have the same ordering experience as BellSouth's Customers:

- 2.5.1 BellSouth shall provide Interprise America with the capability to have Interprise America's Customer orders input to and accepted by BellSouth's Service Order Systems outside of normal business hours, twenty-four (24) hours a day, seven (7) days a week, the same as BellSouth's Customer orders received outside of normal business orders are input and accepted.

- 2.5.2 Such ordering and provisioning capability shall be provided via an electronic interface, except for scheduled electronic interface downtime. Downtime shall not be scheduled during normal business hours and shall occur during times where systems experience minimum usage.
- 2.5.3 Until the Electronic Interface is available, BellSouth shall provide Local Carrier Service Center (LCSC) and Interexchange Carrier Service Center (ICSC) order entry capability to Interprise America.
- 2.6 BellSouth shall provide a Single Point of Contact (SPOC) for all ordering and provisioning contacts and order flow involved in the purchase and provisioning of the BellSouth's unbundled Elements or Combinations. BellSouth's SPOC shall provide to Interprise America a toll-free nationwide telephone number (operational from 8:00 a.m. to 5:00 p.m. in the Eastern and Central time zones) which will be answered by capable staff trained to answer questions and resolve problems in connection with the provisioning of Elements or Combinations. The goal is to move to 24 hour per day, seven (7) days per week, 365 days per year as BellSouth's business needs require.
- 2.7 BellSouth will recognize Interprise America as the customer of record of all Elements or Combinations ordered by Interprise America and will send all notices, invoices and pertinent information directly to Interprise America.

3. **Specific Provisioning Process Requirements**

- 3.1 When Interprise America orders the Local Switching Elements, Interprise America may also obtain all technically available features and functions from the specified BellSouth switch (e.g., BRCS, CLASS, and LASS features).
- 3.2 When requested by Interprise America, BellSouth will schedule installation appointments on a non-discriminatory basis with the BellSouth representative on the line with Interprise America's representative. When electronic interfaces are available, BellSouth will provide Interprise America with access to BellSouth's scheduling system. Prior to Interprise America sending BellSouth the first service order, Interprise America shall review the procedures that all BellSouth service technicians who provide installation service for Interprise America customers shall follow in all of their communications with Interprise America customers. At a minimum, the aforementioned procedures shall assume that: (1) BellSouth technicians shall provide installation and repair service that is at least equal in quality to that provided to BellSouth customers; (2) Installation, maintenance and repair shall take place based on a prioritization schedule devised by mutual agreement of the parties; (3) Customers shall be restored to service and shall be installed based on the priority system devised by mutual agreement of the parties on a non-discriminatory basis and (4) through an escalation procedure prioritize installation and repair scheduling of its own customers.

- 3.3 Upon request from Interprise America, BellSouth will provide an intercept referral message in Tandem Switching Element that includes any new Interprise America telephone number, for the same duration as is provided to BellSouth end-users. This message shall be approved by Interprise America and shall be similar in format to the intercept referral messages currently provided by BellSouth for its own end-users.
- 3.4 The Firm Order Confirmation will provide Interprise America with the Interprise America order number, BellSouth order number, the negotiated service due date, telephone/circuit numbers (as applicable to the service), and the BellSouth service representative name and telephone number. Additional specific data may also be provided, if appropriate.
- 3.5 BellSouth will notify Interprise America of completion activity using the same electronic interface used by Interprise America to submit the service order request. In addition, when a BellSouth Technician is dispatched to complete the order, the service technician will contact Interprise America at the time of completion.
- 3.6 BellSouth will perform pre-service testing as mutually determined by the parties and will provide in writing, or electronically as directed by Interprise America, all test and turn-up results in support of the Elements or Combinations ordered by Interprise America. BellSouth shall provide these test results to Interprise America at the same time BellSouth provides its order-specific Order Completion.
- 3.7 As soon as identified, BellSouth shall notify Interprise America via electronic interface, when available, of Rejections/Errors contained in any of the data element(s) fields contained on any Interprise America Service Request. In the interim, BellSouth will notify Interprise America by telephone or facsimile, as mutually agreed to by the Parties, of such Rejections/Errors.
- 3.8 As soon as identified, BellSouth shall notify Interprise America via electronic interface, when available (unless otherwise notified by Interprise America) of any instances when BellSouth's Committed Due Dates are in jeopardy of not being met by BellSouth on any element or feature contained in any order for Network Elements or Combinations. BellSouth shall concurrently indicate its new committed due date. In the interim, BellSouth will notify Interprise America by telephone or facsimile of such jeopardy, as mutually agreed to by the Parties.
- 3.9 BellSouth will perform testing with Interprise America to test Elements purchased by Interprise America as per Attachment 2, Section 16.1.
- 3.10 **DELETED**

- 3.11 **DELETED**
- 3.12 Interprise America, where available, may choose between SCE/SMS AIN Access and SS7 AIN Access as designated on Interprise America's provisioning order.
- 3.13 BellSouth shall inform Interprise America if a customer action results in reassignment of an AIN trigger from a Interprise America AIN application to some other service provider's application. Such notification shall be completed within twenty-four (24) hours of the action via electronic interface as described in the Account Maintenance requirements specified in the Customer Billing section of this Agreement.
- 3.14 BellSouth shall maintain a database containing AIN trigger configuration and other data necessary to allow AIN service and feature interactions to be determined by Interprise America. BellSouth shall provide Interprise America the capability to make queries on a demand basis to such database. Interprise America recognizes certain combinations of triggers cannot be active simultaneously on a directory number. Information regarding such conflicts will be provided to Interprise America at the time of request.
- 3.15 BellSouth shall provision AIN triggers as requested by Interprise America on its provisioning order. BellSouth will not remove a trigger at the request of an end-user. If an end-user requests removal of a trigger that has been provisioned at the request of Interprise America, the end user will be referred to Interprise America.

4. **General Ordering Requirements**

- 4.1 Upon Interprise America's request through a Suspend/Restore Order, BellSouth shall suspend or restore the functionality of any Network Element. On a non-discriminatory basis as to other BellSouth customers, BellSouth shall implement any restoration priority on a per Network Element basis in a manner that conforms with Interprise America requested priorities.
- 4.2 BellSouth shall provide to Interprise America the functionality of blocking calls (e.g., 700, 900, 976 international calls and any new services of this type individually or in any combination upon request, including bill to third Party and collect calls.) on an individual switching element basis.
- 4.3 When ordering a Local Switching Element, Interprise America may order from BellSouth separate interLATA and intraLATA capabilities (i.e., 2 PICs where available).
- 4.4 Unless otherwise directed by Interprise America, when Interprise America orders an Element, all pre-assigned trunk or telephone numbers currently associated with that Network Element shall be retained without loss of feature

capability and without loss of associated functions including, but not limited to, Directory Assistance and 911/E911 capability, where such features or functions exist.

- 4.5 Unless requested to do so by Interprise America, BellSouth will not require Interprise America when purchasing any Network Element offered pursuant to this Agreement, to purchase individually the sub-elements of such Network Elements.

5. **Ordering Interfaces**

- 5.1 BellSouth shall provide real time electronic interfaces ("EI") for transferring and receiving Service Orders and Provisioning data as specified in Section 16.8 of Attachment 2 and in Attachment 15.

- 5.2 BellSouth shall provide real time provisioning data via an Electronic interface as described in item 6.1 of this section. Provisioning data shall include providing Interprise America the ability: (i) to obtain information on all features and services available, in end-office where customer is provisioned; (ii) to establish if a service call is needed to install the line or service; (iii) to determine the due date and provide information regarding service dispatch/installation schedule, if applicable; (iv) ability to provide an assigned telephone number; and (v) the ability to obtain a customer profile, including customer name, billing and residence address, billed telephone numbers, and identification of features and services subscribed to by customer as set forth in Attachment 15.

- 5.3 BellSouth shall provide the ability to enter a service order via Electronic Interface as described in Subsection 5.1 of this Attachment . The service order shall provide Interprise America the ability to: (i) establish service and order desired features; (ii) establish the appropriate directory listing; and (iii) order intraLATA toll and interLATA toll and/or PIC when applicable in a single, unified order.

6. **BellSouth Provision of Information**

- 6.1 BellSouth shall provide to Interprise America with the initial services request:

6.1.1 **DELETED**

6.1.2 **DELETED**

- 6.1.3 When available with the normal request process, all engineering design and layout information for each network Element;

- 6.1.4 A listing of all technically available functionalities for each Element; and

6.1.5 Advanced information on the details and requirement for planning and implementation of NPA splits.

6.2 **DELETED**

7. **Order Format and Data Elements for Individual Network Elements**

7.1 Interprise America may purchase Network Elements individually and may, at its own option, combine said Elements in any manner it chooses. BellSouth will deliver said individual Elements at any technically feasible interconnection point, e.g. unbundled loops to Interprise America collocation spaces, at no additional charge. Software modifications, e.g., switch translations, necessary for the proper functioning of Interprise America's combined BellSouth Network Elements will be provided by BellSouth at no additional charge.

7.2 In ordering Network Elements, Interprise America will utilize standard industry order formats and data elements developed by the Ordering and Billing Forum (OBF). Until such industry standard order formats and data elements are finalized for all Network Elements, Interprise America and BellSouth will use best efforts to develop an interim process to meet these requirements. Such interim process will utilize the jointly developed EDI ordering interface, the existing ASR ordering interface, and manual intervention as required.

8. **DELETED**

9. **Performance Requirements**

9.1 Interprise America will specify on each order its Desired Due Date (DDD) for completion of that particular order. BellSouth will not complete the order prior to DDD unless early turn-up is needed for testing purposes. BellSouth will notify Interprise America if the DDD cannot be met. BellSouth will make best effort to meet the DDD for Network Element requests.

9.2 BellSouth and Interprise America shall agree upon a minimum interval for the provisioning of each Network Element and appropriate expedite and escalation processes as part of a Workcenter Interface Agreement.

MAINTENANCE

1. BellSouth shall provide repair, maintenance, testing, and surveillance for all Local Services and Unbundled Network Elements in accordance with the terms and conditions of this Attachment. BellSouth will provide Interprise America with at least the capability to provide an Interprise America customer the same experience as BellSouth provides its own customers. The capability provided to Interprise America by BellSouth shall be in accordance with standards or other measurements that are at least equal to the level that BellSouth provides or is required to provide by law and its own internal procedures.
2. BellSouth shall use its best efforts in working with Interprise America to meet maintenance standards for all Local Services and Unbundled Network Elements ordered under this Agreement, as specified in Section 8 of this Attachment. Where applicable to a particular Local Service or an Unbundled Network Element, such maintenance standards shall include, without limitation, standards for testing, network management, call gapping, and notification of upgrades as they become available.
3. BellSouth shall cooperate with Interprise America through a joint implementation team to establish an Electronic Interface for gateway or automated access by Interprise America to BellSouth's maintenance systems and databases in order to allow Interprise America maintenance personnel and customer service representatives to perform the following functions for Interprise America Customers: (i) enter a new customer trouble ticket into the BellSouth maintenance system for a Interprise America Customer; (ii) retrieve and track current status on all Interprise America Customer repair tickets; (iii) receive "estimated time to repair" ("ETTR") on a real-time basis; (iv) initiate a technician dispatch; (v) receive timely notification in the event a repair person is unable to be present for, or anticipates missing, a scheduled repair opportunity; (vi) retrieve all applicable time and material charges at the time of ticket closure (itemized by time spent, price of materials used, procedures employed, amounts incurred in each such category, and total by customer, per event); (vii) perform an electronic test at the time of ticket entry and provide test results to Interprise America.
 - 3.1 BellSouth agrees to use its best efforts to develop and implement as soon as is practicable, but no later than the dates specified in Attachment 15, the electronic interface described above into BellSouth's systems in a manner to provide Interprise America with the capability to provide an Interprise America Customer the same maintenance service as BellSouth provides its own customers.
 - 3.1.1. Until an electronic interface is developed for entering repair tickets directly into BellSouth's maintenance system, BellSouth agrees that Interprise America will report troubles directly to the appropriate BellSouth Repair Center.
 - 3.1.2. **DELETED**

- 3.1.3. Interprise America shall provide BellSouth with a toll free number to be used by BellSouth to contact Interprise America for maintenance or repair issues, such as to obtain authorization to perform billable work not already authorized by a service request.
- 3.1.4. Until an electronic interface exists, BellSouth will provide Interprise America the ability to obtain the status on open maintenance trouble tickets via telephone.
- 3.1.5. Until an electronic interface exists, BellSouth agrees that Interprise America may transmit repair calls to BellSouth's repair bureau and request dispatching a BellSouth technician to an Interprise America customer's premises by telephone. In this interim process, the following standards will apply:
 - 3.1.5.1. BellSouth agrees to provide the status upon Interprise America's request, in an expedient manner. Standards for this status notification will be documented on the Workcenter Interface Agreement.
 - 3.1.5.2. Upon request by Interprise America, BellSouth agrees to provide the status on open maintenance trouble tickets proactively for Interprise America's large business customers. On a non-discriminatory basis as to other BellSouth customers, BellSouth agrees that Interprise America's large business customers' trouble reports will be given priority handling as is done with BellSouth's large business customers' trouble reports. This priority handling shall include immediate expedite and proactive escalation procedures. Guidelines for status and priority handling for large business customers will be documented in the Workcenter Interface Agreement.
- 3.1.6. Until an electronic interface exists, BellSouth agrees that Interprise America may call BellSouth to verify central office features and functions when reporting trouble. BellSouth agrees to work with Interprise America on the initial trouble report to isolate the cause of the trouble and where possible, resolve the feature/function related trouble at that time.
- 3.1.7. BellSouth agrees to advise Interprise America of any central office failure or other major service interruptions that are known at the time of any inquiry or trouble report. Working with Interprise America, BellSouth agrees to use its best efforts to implement a process within 90 days from the effective date of this Agreement, to provide Interprise America with notification, periodic status and resolution of switch failures or any other major service interruptions.
- 3.1.8. BellSouth agrees to provide, via an electronic interface, an Estimated Time To Repair (ETTR) on all trouble reports, an appointment time or a commitment time, as appropriate.
- 3.1.9. BellSouth agrees to develop, with Interprise America's cooperation, a mutually acceptable Workcenter Interface Agreement to document the methods and

procedures for the interim interface within 90 days of the effective date of this Agreement.

- 3.1.9. Prior to Interprise America sending BellSouth the first service order, Interprise America shall review the procedures that all BellSouth service technicians who provide repair service for Interprise America Customers shall follow in all their communications with Interprise America Customers. At a minimum, the aforementioned procedures shall assume that: (1) BellSouth technicians shall provide repair service that is at least equal in quality to that provided to BellSouth customers or any other entity; (2) installation, maintenance and repair shall take place based on a prioritization schedule devised by mutual agreement of the parties; (3) Customers shall be restored to service and shall be installed based on the priority system devised by mutual agreement of the parties on a non-discriminatory basis; and (4) through an escalation procedure to prioritize installation and repair scheduling of its own customers.
4. BellSouth shall provide Interprise America with the same scheduled and non-scheduled maintenance, including, without limitation, required and recommended maintenance intervals and procedures, for all Local Services, Unbundled Network Elements provided to Interprise America under this Agreement that it currently provides for the maintenance of its own network. Procedures for scheduled and non-scheduled maintenance will be documented in the Workcenter Interface Agreement.
 - 4.1. BellSouth shall negotiate the release (authorization to interrupt service) of any Unbundled Network Elements or Large Business customers' service with Interprise America prior to any scheduled maintenance activity which may impact those services.
 - 4.2. For services provided through resale, BellSouth agrees to provide Interprise America with scheduled maintenance for residence and small business customers consistent with that which it provides its own customers. BellSouth agrees to provide Interprise America written notification of Central Office conversions and such conversions will occur after midnight and before 4 a.m.
5. **DELETED**
6. **DELETED**
7. On misdirected calls BellSouth and Interprise America shall advise customers to contact their Local Service Provider and will provide the customer with the Local Service Provider contact number. BellSouth representatives shall interact with Interprise America's customers in an efficient and courteous manner. BellSouth shall be expressly prohibited from engaging in any marketing practices in connection with misdirected calls.

8. BellSouth repair bureau shall conform to the following performance and service quality standards when providing repair and maintenance to Interprise America and Interprise America Customers under this Agreement:
 - 8.1. If service is provided to Interprise America Customers before an Electronic Interface is established between Interprise America and BellSouth, Interprise America will transmit repair calls to the BellSouth repair bureau by telephone. In such event, the speed of answer time for Interprise America will be at least equal to that for BellSouth Customers.
 - 8.2. The BellSouth repair bureau including the Electronic Interface to be established pursuant to Section 3 of this Attachment, shall be on-line and operational twenty-four (24) hours per day, seven (7) days per week except for scheduled electronic interface downtime.
 - 8.3. **DELETED**
 - 8.4. **DELETED**
 - 8.5. BellSouth's response time to emergency network outages shall be as set forth in the Disaster Recovery Plan. Notwithstanding the above, BellSouth's response time shall be at least equal to the response time BellSouth provides to itself and BellSouth's Customers.
 - 8.6. **DELETED**
 - 8.7. **DELETED**
 - 8.8. **DELETED**
 - 8.9. **DELETED**
 - 8.10. BellSouth's repair service centers supporting Interprise America as a Reseller will be the same centers that support BellSouth's end users and, therefore, Interprise America will be supported by BellSouth personnel with the same level of training or certification as those supporting BellSouth's end-users. The Interprise America ACAC, which supports unbundled network elements excluding BellSouth's port, is certified
 - 8.11. BellSouth will provide the telephone number for the duty supervisor in the repair center as the first point of escalation. In the event that further escalation is necessary, that supervisor will be responsible for contacting the next escalation on behalf of Interprise America. At each escalation hand off, BellSouth will provide Interprise America with a proactive status report. This person is also responsible for providing the name and telephone number of the next level in the escalation procedure, if requested.

To escalate an unresolved provisioning and maintenance problem that has been previously reported to the repair center, the unresolved problem should be reported to the repair center and a request for status should be made to the responsible technician or first level supervisor. If the repair center is unable to resolve the provisioning or maintenance problem, the repair center will then be responsible for the internal escalation of the unresolved problem.

8.12. **DELETED**

8.13. Maintenance charges for premises visits by BellSouth technicians shall be billed by Interprise America to its Customer, and not by BellSouth. The BellSouth technician shall, (i) contact Interprise America for authorization, (ii) provide an estimate of time and materials required, (iii) quote time and charges at the completion of the repair visit, (iv) notify Interprise America if a subsequent visit is required. BellSouth will bill maintenance charges for premises visits to Interprise America.

8.14 When maintenance charges are incurred during premise visits, the BellSouth technician shall present the Customer with a form that is consistent with Section 18 of the General Terms and Conditions of this Agreement detailing the time spent, the materials used, and an indication that the trouble has either been resolved, or that additional work will be necessary, in which case, BellSouth technician shall make an additional appointment with the Customer. The BellSouth technician shall obtain the Customer's signature upon said form, and then use the signed form to input maintenance charges into the BellSouth database (accessible by way of the Electronic Interface established pursuant to Section 3 preceding).

TABLE OF CONTENTS

CONNECTIVITY BILLING AND RECORDING.....	1
1. GENERAL	1
2. BILLABLE INFORMATION AND CHARGES.....	1
3. MEET POINT BILLING.....	2
4. COLLOCATION.....	5
5. MUTUAL COMPENSATION.....	5
6. LOCAL NUMBER PORTABILITY	6
7. ISSUANCE OF BILLS - GENERAL	6
8. ELECTRONIC TRANSMISSIONS.....	8
9. TAPE OR PAPER TRANSMISSIONS.....	8
10. TESTING REQUIREMENTS	15
11. ADDITIONAL REQUIREMENTS	16
12. BILL ACCURACY CERTIFICATION.....	16
13. PAYMENT OF CHARGES	16
14. BILLING DISPUTES.....	17
15. LATE PAYMENT CHARGES	18
16. ADJUSTMENTS.....	18
17. RECORDING OF CALL INFORMATION.....	18
18. DELETED.....	19

CONNECTIVITY BILLING AND RECORDING

1. **General**

This Section describes the requirements for BellSouth to bill and record all charges Interprise America incurs for purchasing Local Services for resale and for Network Elements and to provide Meet Point Billing and Mutual Compensation.

2. **Billable Information And Charges**

BellSouth will bill and record in accordance with this Agreement those charges Interprise America incurs as a result of Interprise America purchasing from BellSouth Network Elements and Local Services, as set forth in this Agreement. BellSouth will bill charges for interconnection and charges for unbundled network elements, with the exception of the unbundled ports, through CABS or in the CABS format. BellSouth will format each bill in CABS or in CABS format in accordance with CABS standards and specifications. As an interim process, the Parties have agreed to specific elements of CRIS billing. Those elements are named in Exhibit A attached hereto and incorporated herein by this reference. Each bill shall set forth the quantity and description of each such Network Element or Local Service provided and billed to Interprise America. All charges billed to Interprise America will indicate the state from which such charges were incurred except in cross boundary state situations. BellSouth shall provide Interprise America a listing of the current cross state boundary exchanges.

- 2.1.1 As an interim process, BellSouth will provide Interprise America with bills in the CRIS/CLUB format via paper or other mutually agreed upon medium that includes CONNECT:Direct for those services purchased by Interprise America for resale and for the billing of the unbundled port and loop/port combination in accordance with the specifications and requirements set forth in Exhibit A to this Attachment for no more than one hundred, eighty (180) days after the Effective Date of this Agreement. After that time, BellSouth shall provide bills using only CABS or the CABS format as outlined in this Agreement.

Interprise America and BellSouth will work together in a cooperative effort with the OBF to establish a single billing format and applicable standards. Once the billing standards/system are defined, BellSouth and Interprise America will mutually agree when the standards/system will be implemented.

- 2.2 BellSouth shall provide Interprise America monthly bills that include all charges incurred by and credits and/or adjustments due to Interprise America for those Network Elements or Local Services ordered, established, utilized, discontinued or performed pursuant to this Agreement. Each bill provided by BellSouth to Interprise America shall include: (1) all non-usage sensitive charges incurred for the period beginning with the day after the current bill

- date and extending to, and including, the next bill date; (2) any known unbilled non-usage sensitive charges for prior periods; (3) unbilled usage sensitive charges for the period beginning with the last bill date and extending through the current bill date; (4) any known unbilled usage sensitive charges for prior periods; and (5) any known unbilled adjustments.
- 2.3 The Bill Date, as defined herein, must be present on each bill transmitted by BellSouth to Interprise America, must be a valid calendar date, and not more than (1) year old. Bills shall not be rendered for any charges which are incurred under this Agreement on or before one (1) year preceding Bill Date, except as otherwise permitted by law. In addition, on each bill where "Jurisdiction" is identified, local and local toll charges shall be identified as "Local" and not as interstate, interstate/ interLATA, intrastate, or intrastate/intraLATA. BellSouth will provide from and through dates for charges rendered on all bills. In addition, BellSouth will separately identify business charges from residence charges, as appropriate.
- 2.4 BellSouth shall bill Interprise America for each Network Element or Local Service supplied by BellSouth to Interprise America pursuant to this Agreement at the rates set forth in this Agreement. BellSouth will bill Interprise America based on the actual charges incurred, provided, however, for those usage based charges where actual charge information is not determinable by BellSouth because the jurisdiction (i.e., interstate, interstate/interLATA, intrastate, intrastate/intraLATA, local) of the traffic is unidentifiable, the Parties will jointly develop a process to determine the appropriate charges. Measurement of usage-based charges shall be in actual conversation seconds. The total conversation seconds per chargeable traffic types will be totalled for the entire monthly bill cycle and then rounded to the next whole minute.
- 2.5 **DELETED**
- 2.6 Each Party shall provide the other Party, at no additional charge, a contact person for the handling of any billing questions or problems that may arise during the implementation and performance of the terms and conditions of this Attachment. Billing questions subsequent to implementation will be directed to the billing specialist in the Local Carrier Service Center (LCSC) for CRIS billing and through the Interexchange Carrier Service Center (ICSC) for CABS related issues.
3. **Meet Point Billing**
- 3.1 Where appropriate for unbundled network elements, Interprise America and BellSouth will establish meet-point billing ("MPB") arrangements in accordance with the Meet-Point Billing guidelines adopted by and contained in the OBF's MECAB and MECOD documents, except as modified herein. Both Parties will use their best reasonable efforts, individually and collectively,

- to maintain provisions in their respective federal and state access tariffs, and/or provisions within the National Exchange Carrier Association ("NECA") Tariff No. 4, or any successor tariff to reflect the MPB arrangements identified in this Agreement, in MECAB and in MECOD.
- 3.2 Interprise America and BellSouth will implement the "Multiple Bill/SingleTariff" option in order to bill any interexchange carrier ("IXC") for that portion of the network elements provided by Interprise America or BellSouth. For all traffic carried over the MPB arrangement, Interprise America and BellSouth shall bill each other all applicable elements at the rates specified in this Agreement.
- 3.3 BellSouth shall provide to Interprise America the billing name, billing address, and carrier identification code ("CIC") of the IXCs that may utilize any portion of Interprise America's network in an Interprise America/BellSouth MPB arrangement in order to comply with the MPB Notification process as outlined in the MECAB document. Such information shall be provided to Interprise America in the format and via the medium that the Parties agree. If BellSouth does not have a CIC for any IXC that will utilize a portion of Interprise America's network in an Interprise America/BellSouth MPB arrangement, and for whom BellSouth must supply to Interprise America MPB billing information, BellSouth agrees that it will assist such carrier in obtaining a CIC expeditiously. Until such carrier has obtained a CIC, BellSouth will submit BellSouth's CIC on those MPB records provided to Interprise America for MPB. BellSouth understands and agrees that it will be solely responsible for obtaining any reimbursements from those carriers who have utilized the jointly provided networks of BellSouth and Interprise America.
- 3.4 BellSouth and Interprise America agree that in an MPB arrangement where one Party provides local transport and the other Party provides the end office switching, the Party who provides the end office switching is entitled to bill any residual interconnection charges ("RIC") and common carrier line ("CCL") charges associated with the traffic. The Parties further agree that in those MPB situations where one Party sub-tends the other Party's access tandem, the Party providing the access tandem is only entitled to bill the access tandem fee and any associated local transport charges. The Parties also agree that the Party who provides the end office switching is entitled to bill end office switching fees, local transport charges, RIC and CCL charges, as appropriate, and such other applicable charges.
- 3.5 BellSouth and Interprise America will record and transmit MPB information in accordance with the standards and in the format set forth in this Attachment. BellSouth and Interprise America will coordinate and exchange the billing account reference ("BAR") and billing account cross reference ("BACR") numbers for the MPB arrangements described in this Agreement. Each Party will notify the other if the level of billing or other BAR/BACR elements change, resulting in a new BAR/BACR number.

- 3.6 If MPB data is not processed and delivered by either BellSouth or Interprise America and sent to the other Party within ten (10) days of their recording and in turn such Party is unable to bill the IXC for the appropriate charges, the Party who failed to deliver the data will be held liable for the amount of the unbillable charges. When the subsequent billing company ("SBC") is the recording company, they shall provide the initial billing company ("IBC") the detail billing records on a weekly basis (within five (5) days). If the IBC is the recording company, detail billing record exchange is not necessary. The IBC shall provide the SBC the summary billing records within ten (10) days from the IBC bill date. The Party who failed to deliver the data will be held liable for the amount of the unbillable charges.
- 3.7 If MPB data is not submitted within ten (10) days of their recording or is not in the proper format as set forth in this Agreement, and if as a result the other Party is delayed in billing the IXC for the appropriate charges it incurs, the delaying Party shall pay the other Party a late MPB data delivery charge which will be the total amount of the delayed charges times the highest interest rate (in decimal value) which may be levied by law for commercial transactions, compounded daily for the number of days from the date the MPB charges should have been received to and including the date the MPB charge information is actually received.
- 3.8 Errors in MPB data exchanged by the Parties may be discovered by Interprise America, BellSouth or the billable IXC. Both Interprise America and BellSouth agree to provide the other Party with notification of any discovered errors within two (2) business days of the discovery. The other Party shall correct the error within eight (8) business days of notification and resubmit the data. In the event the errors cannot be corrected within the time period specified above, the erroneous data may be considered lost. If MPB data is lost due to incorrecable errors or otherwise, the Parties shall follow the procedures set forth in Attachment 7, Customer Usage Data Attachment, of this Agreement and compensate the other for the lost MPB billing data.
- 3.9 In the event Interprise America purchases from BellSouth Network Elements, or Combination thereof, in a LATA other than the LATA to or from which the MPB services are homed and in which BellSouth operates an access tandem, BellSouth shall, except in instances of capacity limitations, permit and enable Interprise America to sub-tend the BellSouth access tandem switch(es) nearest to the Interprise America rating point(s) associated with the NPA-NXX(s) to/from which the MPB services are homed. In instances of capacity limitation at a given access tandem switch, Interprise America shall be allowed to sub-tend the next-nearest BellSouth access tandem switch in which sufficient capacity is available. The MPB percentages for each new rating point/access tandem pair shall be calculated in accordance with MECAB and MECOD.

- 3.10 Neither Interprise America nor BellSouth will charge the other for the services rendered, or for information provided pursuant to Section 4 of this Attachment except those MPB charges specifically set forth herein. Both Parties will provide the other a single point of contact to handle any MPB questions.

4. Collocation

When Interprise America collocates with BellSouth in BellSouth's facility as described in this Agreement, capital expenditures (e.g., costs associated with building the "cage"), shall not be included in the bill provided to Interprise America pursuant to this Attachment. All such capital expenses shall be given a unique BAN (as defined in Section 7, below) and invoice number. All invoices for capital expenses shall be sent to the location specified by Interprise America for payment. All other non-capital recurring collocation expenses shall be billed to Interprise America in accordance with this Agreement. The CABS Billing Output Specifications ("BOS") documents provide the guidelines on how to bill the charges associated with collocation. The bill label for those collocation charges shall be entitled "Expanded Interconnection Service." For those nonmechanized bills, the bill label for non-capital recurring collocation expenses shall be entitled "Collocation".

5. Mutual Compensation

- 5.1 The Parties shall bill each other reciprocal compensation in accordance with the standards set forth in this Agreement for Local Traffic terminated to the other Party's customer. Such Local Traffic shall be recorded and transmitted to Interprise America and BellSouth in accordance with this Attachment. When an Interprise America Customer originates traffic and Interprise America sends it to BellSouth for termination, Interprise America will determine whether the traffic is local or toll. When a BellSouth Customer originates traffic and BellSouth sends it to Interprise America for termination, BellSouth will determine whether the traffic is local or toll. Each Party will provide the other with information that will allow it to distinguish among local, intrastate toll and interstate toll traffic. At a minimum, each Party shall utilize NXXs in such a way that the other Party shall be able to distinguish local from intraLATA toll traffic. Where the originating Party cannot provide the terminating Party with actual usage data to enable the terminating Party to distinguish a local call from a toll call, the originating Party will report to the terminating Party its Percent Local Usage ("PLU") factors and the application of such PLUs will determine the amount of local minutes to be billed to the terminating Party. PLUs will be sent monthly or quarterly, as mutually agreed to by the Parties. Each Party may audit the traffic reported to it by the other Party as provided for in Section 11.2 of the General Terms and Conditions of this Agreement. When Interprise America interconnects with BellSouth's network for the purpose of completing local and toll traffic, Interprise America will, at its option, interconnect at either the tandem or end office switch to complete such calls paying local interconnection rates for its customers' local

calls and switched access rates for its customers' toll calls. Such interconnection will be ordered as needed by Interprise America to complete such local and toll calls. Further, the Local Traffic exchanged pursuant to this Attachment shall be measured in billing minutes of use and shall be in actual conversation seconds. The total conversation seconds per chargeable traffic type will be totaled for the entire monthly billing cycle and then rounded to the next whole conversation minute. Reciprocal compensation for the termination of this Local Traffic shall be in accordance with Part IV to this Agreement. Except as provided in Section 11.2 of the General Terms and Conditions of this Agreement, each Party agrees not to charge the other Party for any costs incurred as a result of providing such Party with PLUs in lieu of sending actual usage data to distinguish local and toll traffic.

6. Local Number Portability

6.1 DELETED

6.2 When an IXC terminates an interLATA or IntraLATA toll call to an Interprise America local exchange customer whose telephone number has been ported from BellSouth, the Parties agree that Interprise America shall receive those IXC access charges associated with end office switching, local transport, RIC and CCL, as appropriate. BellSouth shall receive any access tandem fees, dedicated and common transport charges, to the extent provided by BellSouth, and any INP fees (i.e., such as RCF charges) set forth in this Agreement. When a call for which access charges are not applicable is terminated to a Interprise America local exchange customer whose telephone number has been ported from BellSouth, and is terminated on Interprise America's own switch, the Parties agree that the mutual compensation arrangements described in this Agreement shall apply.

7. Issuance of Bills - General

7.1 BellSouth and Interprise America will issue all bills in accordance with the terms and conditions set forth in this Section. BellSouth and Interprise America will establish monthly billing dates ("Bill Date") for each Billing Account Number ("BAN"), as further defined in the CABS document or CRIS elements set forth in Exhibit A as appropriate. On bills BellSouth renders to Interprise America, BANs shall be 13 character alpha/numeric and there shall only be one BAN per Revenue Accounting Office ("RAO"). The Bill Date shall be the same day month to month for all BANs, except that the 4th, 7th or 13th of each month will not be used as a Bill Date for bills BellSouth renders to Interprise America. Interprise America will provide one (1) BAN per state and the bill date will be the same day month to month for all BANs. Each BAN shall remain constant from month to month, unless changed as agreed to by the Parties. Each Party shall provide the other Party at least thirty (30) calendar days written notice prior to changing, adding or deleting a BAN. The Parties will provide one billing invoice associated with each BAN. Each

- invoice must contain an invoice number (which will vary from month to month). The bill date is the only varying invoice number available on the Resale bill. On each bill associated with a BAN, the appropriate invoice number and the charges contained on such invoice must be reflected. All bills must be received by the other Party no later than ten (10) calendar days from Bill Date and at least twenty (20) calendar days prior to the payment due date (as described in this Attachment), whichever is earlier. Any bill received on a Saturday, Sunday or a day designated as a holiday by the Chase Manhattan Bank of New York (or such other bank as Interprise America shall specify) will be deemed received the next business day. If either Party fails to receive billing data and information within the time period specified above, the payment due date will be extended by the number of days the bill is late.
- 7.2 BellSouth and Interprise America shall issue all CABS bills or bills in CABS format containing such billing data and information in accordance with CABS Version 26.0, Issue 4, or such later versions of CABS as are published by BellCore, or its successor, except that if the Parties enter into a meet-point billing arrangement, such billing data and information shall also conform to the standards set forth in the MECAB document, or such later versions as are adopted by BellCore, or its successor. To the extent that there are no CABS or MECAB standards governing the formatting of certain data, such data shall be issued in the format specified by Interprise America. Consistent with Section 2.1.1 of this Attachment 6, BellSouth may issue Interprise America Resale and unbundled port Connectivity bills in CRIS/CLUB format as provided herein for no more than one hundred eighty (180) days after the Effective Date of this Agreement.
- 7.3 Within thirty (30) days of finalizing the chosen billing media, each Party will provide to the other Party written notice of which bills are to be deemed the official bills to assist the Parties in resolving any conflicts that may arise between the official bills and other bills received via a different media which purportedly contain the same charges as are on the official bill. If either Party requests additional copy(ies) of a bill, such Party shall pay the other Party a reasonable fee per additional bill copy, unless such copy was requested due to loss or destruction due to causes beyond the requesting party's control, errors, omissions, or corrections or the failure of the transmission to comply with the specifications set forth in this Agreement.
- 7.4 When sending bills via electronic transmission, to avoid transmission failures or the receipt of billing information that cannot be processed, the Parties shall provide each other with their respective process specifications. Each Party shall comply with the mutually acceptable billing processing specifications of the other. Interprise America and BellSouth shall provide each other reasonable notice if a billing transmission is received that does not meet such Party's specifications or that such Party cannot process. Such transmission shall be corrected and resubmitted to the other Party, at the resubmitting Party's sole expense, in a form that can be processed. The payment due

date for such resubmitted transmissions will be twenty (20) days from the date that the transmission is received in a form that can be processed and that meets the specifications set forth in this Attachment.

8. Electronic Transmissions

8.1 BellSouth and Interprise America agree that each Party will transmit billing information and data in the appropriate CABS format electronically via CONNECT:Direct (formerly known as Network Data Mover) to the other Party at the location specified by such Party. The Parties agree that a T1.5 or 56kb circuit to Gateway for CONNECT:Direct is required. Interprise America data centers will be responsible for originating the calls for data transmission via switched 56kb or T1.5 lines. If BellSouth has an established CONNECT:Direct link with Interprise America, that link can be used for data transmission if the location and applications are the same for the existing link. Otherwise, a new link for data transmission must be established. Any changes to either Party's CONNECT:Direct Node ID must be sent to the other Party no later than twenty-one (21) calendar days before the changes take effect. Parties agree to exchange information necessary to establish CONNECT:Direct.

8.2 DELETED

9. Tape or Paper Transmissions

9.1 In the event either Party does not temporarily have the ability to send or receive data via CONNECT:Direct, that Party will transmit billing information to the other party via magnetic tape or paper, as agreed to by Interprise America and BellSouth. Billing information and data contained on magnetic tapes or paper for payment shall be sent to the Parties at the following locations. The Parties acknowledge that all tapes transmitted to the other Party via U.S. Mail or Overnight Delivery and which contain billing data will not be returned to the sending Party.

TO Interprise America:

Tape : Resale Bill Transmissions via Overnight Delivery:	Interprise America National Expansion Accounts Payable Attn: Billing Manager 1999 Broadway, 7th Floor Denver, CO 80202
---	---

Tape : UNE Bills Transmissions via Overnight Delivery:	Interprise America National Expansion Accounts Payable Attn: Billing Manager 1999 Broadway, 7th Floor Denver, CO 80202
---	---

Paper: Resale Bill Transmissions via Overnight Delivery:	Interprise America National Expansion Accounts Payable Attn: Billing Manager 1999 Broadway, 7th Floor Denver, CO 80202
---	---

Paper: UNE Bills Transmissions via Overnight Delivery:	Interprise America National Expansion Accounts Payable Attn: Billing Manager 1999 Broadway, 7th Floor Denver, CO 80202
---	---

TO BellSouth:

Tape Transmissions:	Attn:
Paper Transmissions:	Attn:

- 9.2 Each Party will adhere to the tape packaging requirements set forth in this subsection. Where magnetic tape shipping containers are transported in freight compartments, adequate magnetic field protection shall be provided by keeping a typical 6-inch distance from any magnetic field generating device (except a magnetron-tape device). The Parties agree that they will only use those shipping containers that contain internal insulation to prevent damage. Each Party will clearly mark on the outside of each shipping container its name, contact and return address. Each Party further agrees that it will not ship any Connectivity Billing tapes in tape canisters.
- 9.3 All billing data transmitted via tape must be provided on a cartridge (cassette) tape and must be of high quality, conform to the Parties' record and label standards, 9-track, odd parity, 6250 BPI, group coded recording mode and extended binary-coded decimal interchange code ("EBCDIC"). Each reel of

tape must be 100% tested at 20% or better "clipping" level with full width certification and permanent error free at final inspection. Interprise America reserves the right to destroy a tape that has been determined to have unrecoverable errors. Interprise America also reserves the right to replace a tape with one of equal or better quality.

- 9.4 Billing data tapes shall have the following record and label standards. The dataset serial number on the first header record of an IBM standard tape label also shall have the following format.

	CABS BOS	
Record Length	225 bytes (fixed length)	
Blocking factor	84 records per block	
Block size	18,900 bytes per block	
Labels	Standard IBM Operating System	

- 9.5 A single 6-digit serial number must appear on the external (flat) surface of the tape for visual identification. This number shall also appear in the "dataset serial number field" of the first header record of the IBM standard tape label. This serial number shall consist of the character "V" followed by the reporting location's four digit Originating Company Code and a numeric character chosen by the sending company. The external and internal label shall be the same. The dataset name shall appear on the flat side of the reel and also in the "data set name field" on the first header record of the IBM standard tape label. BellSouth's name, address, and contact shall appear on the flat side of the cartridge or reel.

- 9.6 Tape labels shall conform to IBM OS/VS Operating System Standards contained in the IBM Standard Labels Manual (GC26-3795-3). IBM standard labels are 80-character records recorded in EBCDIC, odd parity. The first four characters identify the labels:

Volume 1	Volume label
HDR1 and HDR2	Data set header labels
EOV1 and EOV2	Data set trailer labels (end-of-volume for multi-reel files)
EOF1 and EOF2	Data set trailer labels (end-of-data-set)

The HDR1, EOV1, and EOF1 labels use the same format and the HDR2, EOV2, and EOF2 labels use the same format.

- 9.7 The Standard Volume Label Format (Vol. 1) is described below:

FIELD NAME	CONTENTS
Label Identifier (3 bytes)	The characters "VOL" identify this label as a volume label.

Label Number (1 byte)	The relative position of this label within a set of labels of the same type; it is always a 1 for the IBM standard volume label.
Volume Serial Number (6 bytes)	A unique identification code, normally numeric characters (000001-999999), but may be alpha-numeric; if fewer than 6 characters, must be left-justified. This same code should also appear on the external (flat) surface of the volume for visual identification.
Reserved (1 byte)	Reserved for future use - should be recorded as blanks.
VTOC Pointer (10 bytes)	Direct-access volumes only. This field is not used for tape volumes and should be recorded as blanks.
Reserved (10 bytes)	Reserved for future use - should be recorded as blanks.
Owner Name and Address Code(10 bytes)	Indicates a specific customer, person, installation, department, etc., to which the volume belongs. Any code or name is acceptable.
Reserved (29 bytes)	Reserved for future use - should be recorded as blanks.

9.8 The IBM Standard Dataset Label 1 Format (HDR1, EOVI, EOF1) is described below:

FIELD NAME	CONTENTS
Label Identifier (3 bytes)	Three characters that identify the label are: HDR Header label (at the beginning of a dataset) EOV Trailer label (at the end of a tape volume, when the dataset continues on another volume) EOF Trailer label (at the end of a dataset).
Label Number (1 byte)	The relative position of this label within a set of labels of the same type; it is always a 1 for dataset label 1.
Dataset Identifier (17 bytes)	The rightmost 17 bytes of the dataset name (includes GnnnnVnn if the dataset is part of a generation data group). If the dataset name is less than 17 bytes, it is left-justified and the remainder of this field is padded with blanks.

FIELD NAME	CONTENTS
Dataset Serial Number (6 bytes)	The volume serial number of the tape volume containing the dataset. For multi-volume datasets, this field contains the serial number of the first volume of the aggregate created at the same time. The serial number can be any 6 alphanumeric characters, normally numeric (000001-999999). If the number of characters is fewer than 6 characters, the code must be left-justified and followed by blanks.
Volume Sequence Number (4 bytes)	A number (0001-9999) that indicates the order of volume within the multi-volume group created at the same time. This number is always 0001 for a single volume dataset.
Dataset Sequence Number (4 bytes)	A number (0001-9999) that indicates the relative position of the dataset within a multi-dataset group. This number is always 0001 for a single dataset organization.
Generation Number (4 bytes)	If the dataset is part of a generation data group, this field contains a number from 0001 to 9999 indicating the absolute generation number (the first generation is recorded as 0001). If the dataset is not part of a generation data group, this field contains blanks.
Version Number Of Generation (2 bytes)	If the dataset is part of a generation data group, this field a number from 00 to 99 indicating the version number of the generation (the first version is recorded as 00). If the dataset is not part of a generation data group, this field contains blanks.
Creation Date (6 bytes)	Year and day of the year when the dataset was created. The date is shown in the format byydd where: b = blank yy = year(00-99) ddd = day(001-366)
Expiration Date (6 bytes)	Year and day of the year when the dataset may be scratched or overwritten. The data is shown in the format byydd where: b = blank yy = year (00-99) ddd = day (001-366)

FIELD NAME	CONTENTS
Dataset Security (1 byte)	A code number indicating the security status of the dataset is as follows: 0 No password protection 1 Password protection Additional identification of the dataset is required before it can be read, written, or deleted (ignored if volume is RACF-defined) 3 Password protection Additional identification of the dataset is required before it can be read, written, or deleted (ignored if volume is RACF-defined).
Block Count (6 bytes)	This field in the trailer label shows the number of data blocks in the dataset on the current volume. This field in the header label is always zeros (000000).
System Code (13 bytes)	Unique code that identifies the system.
Reserved (7 bytes)	Reserved for future use - should be recorded as blanks.

9.9 The IBM Standard Dataset Label 2 Format (HDR2, EOVS, EOF2) always follows dataset label 1 and contains additional information about the associated dataset as described below:

Label Identifier (3 bytes)	Three characters that identify the label are as follows: HDR Header label (at the beginning of a dataset) EOV Trailer label (at the end of a tape volume, when the dataset continues on another volume) EOF Trailer label (at the end of a dataset).
Label Number (1 byte)	The relative position of this label within a set of labels of the same type; it is always a 2 for dataset label 2.
Record Format (1 byte)	An alphabetic character that indicates the format of records in the associated dataset as follows: F Fixed length V Variable length U Undefined length.

Block Length (5 bytes)	A number up to 32760 that indicates the block length, in bytes. Interpretation of the number depends on the following associated record format in Field 3: Format F - Block length (must be a multiple of the logical record length in Field 5) Format V - Maximum block length (including the 4 byte length indicator in the block) Format U - Maximum block length.
Record Length (5 bytes)	A number that indicates the record length, in bytes. Interpretation of the number depends on the following associated record format in Field 3: Format F - Logical record length Format V - Maximum logical record length (including the 4 byte length indicator in the records) Format U - Zeros.
Tape Density (1 byte)	A code indicating the record density of the tape, as follows: Recording Density DEN Value 9-Track Tape 3 1600 (PE) 4 6250 (GCR) PE - is for phase encoded mode GCR - is for group coded recording mode.
Dataset Position (1 byte)	A code, indicating a volume switch, is as follows: 0 - No volume switch has occurred 1 - A volume switch previously occurred.
Job/Job Step (17 bytes)	Identification of the job and job step that created the dataset. The first 8 bytes contain the name of the job, the ninth byte is a slash (/), and the final 8 bytes contain the name of the job step.
Tape Recording Technique (2 bytes)	A code or blanks indicating the tape recording technique used. This field is recorded as blanks for 9-track tape. The only technique available for 9-track tape is odd parity and no translation.
Control Characters (1 byte)	A code indicating whether a control character set was used to create the dataset and the type of control characters used: A Contains ASCII control characters M Contains machine control characters b Contains no control characters.
Reserved (1 byte)	Reserved for future use - should be recorded as blanks.

Block Attribute (1 byte)	A code indicating the block attribute used to create the dataset: B Blocked records S Spanned records R Blocked and spanned records b No blocked and no spanned records.
Reserved (8 bytes)	Bytes 40-42 - reserved for future use -should be blanks. Bytes 43-47 - (3420 tape units only) serial number of creating tape unit. Blank for other units.
Checkpoint Dataset (1 byte)	In VS2-Release 2, this byte contains the identifier character C if the dataset is a checkpoint dataset; the byte is blank if the dataset is not a check point dataset or in other releases of the VS systems.
Reserved (32 bytes)	Reserved for future use - should be recorded as blanks.

10. Testing Requirements

- 10.1 Within thirty (30) days of the execution of this Agreement, BellSouth shall send to Interprise America bill data in the appropriate mechanized format (i.e. CABS or CRIS) for testing to ensure that bills can be processed and that bills comply with the requirements of this Attachment 6. After receipt of the test data from BellSouth, Interprise America will notify BellSouth if the billing transmission meets Interprise America's testing specifications. If the transmission fails to meet Interprise America's testing specifications, BellSouth shall make the necessary corrections. At least three (3) sets of testing data must meet Interprise America's testing specifications prior to BellSouth sending Interprise America a mechanized production bill for the first time via electronic transmission or tape. Thereafter, BellSouth may begin sending Interprise America mechanized production bills on the next Bill Date, or within ten (10) days, whichever is later.
- 10.2 At least thirty (30) days prior to changing mechanized formats (e.g., CABS), BellSouth shall send to Interprise America bill data in the appropriate mechanized format for testing to ensure that the bills can be processed and that the bills comply with the requirements of this Attachment. BellSouth agrees that it will not send Interprise America bill data in the new mechanized format until such bill data has met the testing specifications as set forth in this subsection.
- 10.3 BellSouth shall provide to Interprise America's Billing Manager, located at 1999 Broadway, 7th Floor, Denver, Co 80202, BellSouth's originating or state level company code so that it may be added to Interprise America's internal tables at least thirty (30) calendar days prior to testing or prior to a change in BellSouth's originating or state level company code.

- 10.4 During the testing period, BellSouth shall transmit to Interprise America billing data and information via paper transmission. Test tapes shall be sent to Interprise America at the same locations as "production" or live files.

Test Tapes:	Interprise America National Expansion Accounts Payable Attn: Billing Manager 1999 Broadway, 7th Floor Denver, CO 80202
-------------	---

11. **Additional Requirements**

- 11.1 BellSouth agrees that if it transmits data to Interprise America in a mechanized format, BellSouth will also comply with the following specifications which are not contained in CABS guidelines but which are necessary for Interprise America to process billing information and data:

- The BAN shall not contain embedded spaces or low values.
- The Bill Date shall not contain spaces or non-numeric values.
- Each bill must contain at least one detail record.
- Any "From" Date should be less than the associated "Thru" Date and neither date can contain spaces.
- The Invoice Number must not have embedded spaces or low values.

11.2 **DELETED**

12. **Bill Accuracy Certification**

Within 120 days of the execution of this Agreement, Interprise America and BellSouth will agree upon a CRIS billing quality assurance program that will eliminate the need for post-billing reconciliation. Appropriate terms for access to any BellSouth documents, systems, records, and procedures for the billing, recording of charges will be part of that program. In the event the Parties are unable to reach agreement on such a program, the matter will be resolved pursuant to the disputes process provided in Attachment 1.

13. **Payment Of Charges**

- 13.1 Subject to the terms of this Agreement, Interprise America and BellSouth will pay each other within thirty (30) calendar days from the Bill Date, or twenty (20) calendar days from the receipt of the bill, whichever is later. If the payment due date is a Sunday or is a Monday that has been designated a bank holiday by the Chase Manhattan Bank of New York (or such other bank as Interprise America specifies), payment will be made the next business day. If the payment due date is a Saturday or is on a Tuesday, Wednesday, Thursday or Friday that has been designated a bank holiday by the Chase

Manhattan Bank of New York (or such other bank as Interprise America specifies), payment will be made on the preceding business day.

13.2 Payments shall be made in U.S. Dollars via electronic funds transfer (“EFT”) and/or American Clearinghouse (“ACH”) to the other Party’s bank account. At least thirty (30) days prior to the first transmission of billing data and information for payment, BellSouth and Interprise America shall provide each other the name and address of its bank, its account and routing number and to whom billing payments should be made payable. If such banking information changes, each Party shall provide the other Party at least sixty (60) days written notice of the change and such notice shall include the new banking information. The Parties will render payment via EFT and/or ACH. Interprise America will provide BellSouth with one address to which such payments shall be rendered and BellSouth will provide to Interprise America with only one address to which such payments shall be rendered. In the event Interprise America receives multiple bills from BellSouth which are payable on the same date, Interprise America may remit one payment for the sum of all bills payable to BellSouth’s bank account specified in this subsection. Each Party shall provide the other Party with a contact person for the handling of billing payment questions or problems.

14. **Billing Disputes**

14.1 Each Party agrees to notify the other Party upon the discovery of a billing dispute. In the event of a billing dispute, the Parties will endeavor to resolve the dispute within sixty (60) calendar days of the Bill Date on which such disputed charges appear. Resolution of the dispute is expected to occur at the first level of management resulting in a recommendation for settlement of the dispute. A mutually agreed upon escalation process will be established for the CRIS resale bill as part of the quality assurance program developed pursuant to Section 12 of this Attachment 6. In the interim, in the event of a billing dispute that cannot be resolved within the 60-day timeframe, the process described in Exhibit B to this Attachment shall be followed.

14.2 If a Party disputes a charge and does not pay such charge by the payment due date, such charges shall be subject to late payment charges as set forth in the Late Payment Charges provision of this Attachment. If a Party disputes charges and the dispute is resolved in favor of such Party, the other Party shall credit the bill of the disputing Party for the amount of the disputed charges along with any late payment charges assessed no later than the second Bill Date after the resolution of the dispute. Accordingly, if a Party disputes charges and the dispute is resolved in favor of the other Party, the disputing Party shall pay the other Party the amount of the disputed charges and any associated late payment charges assessed no later than the second bill payment due date after the resolution of the dispute. In no event, however, shall any late payment charges be assessed on any previously assessed late payment charges.

15. Late Payment Charges

If either Party fails to remit payment for any charges described in this Attachment by the payment due date, or if a payment or any portion of a payment is received by either Party after the payment due date, or if a payment or any portion of a payment is received in funds which are not immediately available to the other Party, then a late payment penalty shall be assessed. For bills rendered by BellSouth for payment by Interprise America, the late payment charge shall be calculated based on the portion of the payment not received by the payment due date times the late factor as set forth in the following BellSouth tariffs, based upon the service for which payment was not received: for general subscriber services, Section A2 of the General Subscriber Services Tariff; for private line service, Section B2 of the Private Line Service Tariff; and for access service, Section E2 of the Access Service Tariff. For bills rendered by Interprise America for payment by BellSouth, the late payment charge shall be calculated based on the portion of the payment not received by the payment date times the lesser of (i) one and one-half percent (1 1/2%) per month or (ii) the highest interest rate (in decimal value) which may be charged by law for commercial transactions, compounded daily for the number of days from the payment date to and including the date that payment is actually made. In no event, however, shall interest be assessed by Interprise America on any previously assessed late payment charges. BellSouth shall only assess interest on previously assessed late payment charges in a state where it has authority pursuant to its tariffs.

16. Adjustments

Subject to the terms of this Attachment, BellSouth will reimburse Interprise America for incorrect billing charges; overcharges; Local Services Elements, or any Combination thereof, ordered or requested but not delivered; interrupted Local Services associated with any Element, or combination thereof, ordered or requested; Local Services, Elements, or Combination thereof, of poor quality; and installation problems if caused by BellSouth. Such reimbursements shall be set forth in the appropriate section of the CABS bill pursuant to CABS, standards.

17. Recording of Call Information

- 17.1 Where Telecommunications Services are being resold or unbundled Network Elements are being utilized, the Parties agree to record call information in accordance with this subsection. To the extent technically feasible, each Party will record and process the usage sensitive call detail information associated with the other Party's local exchange customer. The call records for the charged number shall be provided at a Party's request and shall be formatted pursuant to BellCore standards and the terms and conditions of this Agreement. BellSouth and Interprise America agree that they will retain, at each Party's sole expense, copies of all AMA records transmitted to the other

Party for at least seven (7) calendar days after transmission to the other Party.

17.2 Each Party will provide the other Party with a carrier identification code ("CIC") on each EMR record transmitted to the other Party. If BellSouth does not have a CIC for any local exchange carrier, BellSouth or IXC for whom BellSouth must supply to Interprise America billing records or information pursuant to this Attachment, BellSouth agrees that it will assist the local exchange carrier, BellSouth or IC in obtaining a CIC expeditiously. Until the local exchange carrier, BellSouth or IXC has received a CIC, BellSouth agrees that it will submit its CIC to Interprise America on those records for billing and payment. BellSouth further agrees that it will then be responsible for obtaining reimbursement for the respective charges from the appropriate carrier. Likewise, if Interprise America does not have a CIC for any local exchange carrier, BellSouth or IXC for whom Interprise America must supply to BellSouth billing records or information pursuant to this Attachment, Interprise America agrees that it will assist the local exchange carrier, BellSouth or IXC in obtaining a CIC expeditiously. Until the local exchange carrier, BellSouth or IXC has received a CIC, Interprise America agrees that it will submit its CIC to BellSouth on those records for billing and payment. Interprise America further agrees that it will then be responsible for obtaining reimbursement for the respective charges from the appropriate carrier.

17.3 **DELETED**

17.3.1 **DELETED**

17.3.2 **DELETED**

17.3.3 **DELETED**

17.4 The Parties agree that they will provide each other a single person to contact regarding any data exchange problems.

18. **DELETED**

Exhibit A

**REQUIREMENTS FOR NON-CABS BILLING
OF
Interprise America LOCAL SERVICE RESALE**

Interprise America and BellSouth agree to the following requirements for non-CABS billing for Local Service Resale:

- BellSouth will provide a 13 character alpha-numeric Billing Account Number (BAN)
- BellSouth will provide one (1) BAN per Regional Accounting Office (RAO)
- BellSouth will provide one (1) bill cycle for all BANs / RAOs excluding the 4th, 7th and 13th bill cycles
- BellSouth will render the bill within ten (10) days of the bill date
- Interprise America will render payment 30 days from the bill date or 20 days from the date the bill is received, whichever is greater
- Interprise America will render payment via wire transfer and/or ACH to the existing CABS billing address
- BellSouth will render billing for PIC charges separately
- BellSouth will bill monthly service charges in advance of the bill date
- BellSouth will bill usage charges in arrears of the bill date
- BellSouth will identify all charges by incurred state except in cross boundary situations
- All local billing is considered jurisdiction '5'
- BellSouth will uniquely identify the local billing BANs as Type Of Account 'Q'
- BellSouth will separately identify business and residence charges via 1FB or 1FR
- BellSouth will provide From and Through dates for all local billing

Exhibit B

**BELLSOUTH LOCAL CARRIER SERVICE CENTER (LCSC)
ESCALATION LIST**

LOCAL CARRIER SERVICE CENTER

Telephone Numbers	Office800-872-3116 Local Service Requests, LSR Questions, Billing Inquiries and General Assistance Fax Number800-872-7059 All Forms
Managers	Director Barbara Warren700-451-0853 Manager Paula Murphy700-451-0883
Mailing Address	Local Carrier Service Center (LCSC) BellSouth Room D-20 5147 Peachtree Industrial Boulevard Chamblee, GA 30341
Hours of Operation	8:30 AM to 5:00 PM EST Monday - Friday
Holidays Observed	New Years Day Memorial Day Independence Day Labor Day Thanksgiving Day Christmas Day
Process	The long-term escalation process will be developed as part of the Quality Assurance program outlined in paragraph 12 of this attachment. In the interim, Interprise America will escalate any billing discrepancies to the BellSouth LCSC Manager. If resolution is not attained within 30 days, Interprise America will escalate the discrepancy to the BellSouth Director. If the billing discrepancy is not resolved within 30 days, Interprise America will obtain the name and number of the next level manager from the BellSouth Director and continue escalating until a resolution is reached.

TABLE OF CONTENTS

PROVISION OF CUSTOMER USAGE DATA 3

1. Introduction 3

2. General Requirements for Recorded Usage Data 3

3. Usage Data Specifications 3

4. Recorded Usage Data Format 4

5. Recorded Usage Data Reporting Requirements 4

6. Recording Failures 5

7. Charges 7

8. Local Account Maintenance 7

9. Incollect/Outcollect Procedures 9

APPENDIX I 14

APPENDIX II 15

SECTION I: SCOPE 16

SECTION II: RECORDED USAGE TO BE TRANSMITTED TO Interprise America 18

1. General 18

2. Usage To Be Transferred To Interprise America 18

3. Interprise America Usage (Recording “Flat Rate” Service) 18

SECTION III: BELLSOUTH TO Interprise America USAGE FEED 20

1. General 20

2. Detailed EMR Record Edits. 20

3. Duplicate Record Checks. 20

4. BellSouth to Interprise America Usage Feed 20

SECTION IV: Interprise America PROCESSING REQUIREMENTS 25

- 1. General.....25
- 2. Interprise America Rating Process25
- SECTION V: TEST PLANS AND ACTIVITIES.....27
- 1. General.....27
- 2. Interface Testing.....27
- 3. Operational Test.....27
- 4. Test File.....28
- SECTION VI: POST DEPLOYMENT ACTIVITIES.....29
- 1. General.....29
- 2. Control Maintenance And Review.....29
- 3. BellSouth Software Changes.....35
- 4. Interprise America Software Changes.....35
- 5. Post Conversion Test Plan35
- SECTION VII-SUBAPPENDICES.....38

PROVISION OF CUSTOMER USAGE DATA

1. Introduction

- 1.1 This Attachment sets forth the terms and conditions for BellSouth's provision of Recorded Usage Data (as defined in this Attachment) to Interprise America. At Interprise America's request, Recorded Usage Data shall be provided by BellSouth to Interprise America when Interprise America purchases Network Elements or Local Services from BellSouth.

2. General Requirements for Recorded Usage Data

- 2.1 BellSouth shall provide Interprise America with Recorded Usage Data in accordance with this Attachment 7.

2.2 DELETED

- 2.3 BellSouth shall retain Recorded Usage Data in accordance with applicable law and regulation.

3. Usage Data Specifications

BellSouth will record usage for Interprise America Customers in the same manner that it uses to record usage for BellSouth end users, based on the particular Class of Service and the type of exchange line service involved. Recorded usage data includes, but is not limited to:

- Completed Calls
- Use of feature activation's for Call Return, Repeat Dialing, and Usage Sensitive Three Way Calling
- Rated Calls to Information Service Providers reach via BellSouth facilities
- Calls completed via BellSouth provided Operator Services where BellSouth provides such service to Interprise America's local service Customer
- For BellSouth provided Centrex Service, Station Level Detail
- Records shall include complete call detail and complete timing information for the type of service involved

- 3.1 BellSouth shall provide to Interprise America Recorded Usage Data for Interprise America Customers only. BellSouth will not submit other carrier local usage data as part of the Interprise America Recorded Usage Data.

3.2 DELETED

3.3 **DELETED**

3.4 End user customer usage records and station level detail records shall be in packs in accordance with EMR standards.

4. **Recorded Usage Data Format**

4.1 BellSouth will provide Recorded Usage Data in the EMR format and by category, group and record type, as specified in the Interprise America Customer Usage Requirements, ("Data Requirements"), which is attached hereto and incorporated herein as Appendix II which shall be updated periodically by mutual agreement, in writing. BellSouth will provide the usage in accordance with BellCore EMR Standards. BellSouth will accept requests for customization from Interprise America via the BFR process.

4.2 BellSouth shall include the Working Telephone Number (WTN) of the call originator on each EMR call record, if appropriate for the type of service involved.

4.3 End user customer usage records and station level detail records shall be in packs in accordance with EMR standards.

4.4 Interprise America requested that BellSouth transmit separate files with unique job names for each state. However, BellSouth transmit files by RAO, RAOs can cross state lines.

BellSouth will create a consolidated single file of usage data for each billing cycle each business day. This Daily Usage File will contain separate packs of data for each BellSouth RAO where Interprise America has service arrangements with BellSouth. Each pack will have a unique invoice sequence number based on the From RAO in the pack header.

5. **Recorded Usage Data Reporting Requirements**

5.1 BellSouth shall segregate and organize the Recorded Usage Data in accordance with Interprise America's instructions.

5.2 BellSouth shall provide Recorded Usage Data to one Interprise America biller location as designated by Interprise America.

5.3 BellSouth shall transmit Data Requirements formatted Recorded Usage Data to Interprise America via CONNECT:Direct as designated by Interprise America. The charge for transmitting the Data Requirements is set forth in Part IV of this Agreement.

5.4 Interprise America will test and certify the CONNECT:Direct interface to ensure the accurate receipt of Recorded Usage Data. BellSouth shall

make any changes necessary to pass the Interprise America CONNECT:Direct certification process.

- 5.5 BellSouth shall provide Recorded Usage Data to Interprise America on a schedule to be determined by the Parties once a day for each regular business day, five days a week except holidays as designated by Interprise America.
- 5.6 BellSouth will establish a single point of contact to respond to Interprise America call usage, data error, and record transmission inquiries.
- 5.7 The Recorded Usage Data EMR format, content, and transmission process will be tested as specified by Interprise America.
- 5.8 When requested by Interprise America for security purposes, BellSouth shall use its best efforts to provide Interprise America with Recorded Usage Data within the time frame specified by Interprise America. If not available in EMR format, the Recorded Usage Data may be provided in AMA format.

6. **Recording Failures**

- 6.1 When BellSouth records usage and fails to record messages, regardless of whether Interprise America or BellSouth are performing the billing function, BellSouth shall notify Interprise America of the amount of estimated Interprise America revenue in accordance with Section 6.3. BellSouth shall compensate Interprise America for the net loss to Interprise America as a result of Interprise America's inability to bill for services associated with the recording failure. Net loss shall be defined as the gross revenues to Interprise America attributable to the recording failures less the cost of services that BellSouth was unable to bill Interprise America and the internal costs Interprise America avoided as a result of the recording failure.
 - 6.1.1 BellSouth shall include the amount of unbillable Interprise America revenue that is attributable to failures to record, within the monthly billing statement.

6.2 **Lost, Damaged, Destroyed Message Data**

- 6.2.1 When Interprise America message data are lost, damaged, or destroyed as a result of BellSouth error or omission when BellSouth is performing the billing and/or recording function, and the data cannot be recovered or resupplied in time for the time period during which messages can be billed according to legal limitations less thirty (30) days or such other time periods that may be agreed to by the Parties within the limitations of the law, BellSouth shall notify Interprise America of the amount of estimated

Interprise America revenue in accordance with Section 6.3 and BellSouth shall compensate Interprise America for this lost revenue.

6.2.2 When Interprise America message data are lost, damaged, or destroyed as a result of BellSouth error or omission when Interprise America is performing the billing and/or recording function, and the data cannot be recovered or resupplied in time for the time period during which messages can be billed according to legal imitations, or such other time periods that may be agreed to by the Parties within the limitations of the law less thirty (30) days BellSouth shall notify Interprise America of the amount of estimated Interprise America revenue in accordance with Section 6.3 and BellSouth shall compensate Interprise America for this lost revenue.

6.2.3 BellSouth shall notify Interprise America in advance of the date of monthly billing statement that shall contain such adjustments. BellSouth shall provide sufficient information to allow Interprise America to analyze the data.

6.3 **Recording Quality**

6.3.1 **Material Loss**

BellSouth shall review its daily controls to determine if data has been lost. BellSouth shall use the same procedures to determine an Interprise America material loss as it uses for itself. The message threshold used by BellSouth to determine a material loss of its own messages will also be used to determine a material loss of Interprise America messages. When it is known that there has been a loss, actual message and minute volumes should be reported if possible. Where actual data are not available, a full day shall be estimated for the recording entity as outlined in the paragraph below titled Estimating Volumes. The loss is then determined by subtracting recorded data from the estimated total day business.

6.3.2 **Complete Loss**

Estimated message and minute volumes for each loss consisting of an entire/tape or file lost in transit, lost after receipt, degaussed before processing, received blank or unreadable, etc. shall be reported. Also the loss of one or more boxes of operator tickets shall be estimated and reported if applicable.

6.3.3 **Estimated Volumes**

From message and minute volume reports for the entity experiencing the loss, BellSouth shall secure message/minute counts for the corresponding day of the weeks for four (4) weeks preceding the week following that in which the loss occurred. BellSouth shall apply the appropriate Average

Revenue Per Message (ARPM) to the estimated message volume to arrive at the estimated lost revenue.

Exceptions:

A. If the day of loss is not a holiday but one (1) (or more) of the preceding corresponding days is a holiday, use an additional number of weeks in order to procure volumes for two (2) non-holidays.

B. If the call or usage data lost represents calls or usage on a weekday which is a holiday (except Christmas and Mothers Day), use volumes from the preceding and following Sunday.

C. If the call or usage data lost represents calls or usage on Mother's Day or Christmas, use volumes from that day in the preceding year (if available).

D. In the selection of corresponding days for use in developing estimates, consideration shall be given to other conditions which may affect call volumes such as tariff changes, weather and local events (conventions, festivals, major sporting events, etc.) in which case the use of other days may be more appropriate.

6.4 **Unbillable Compensation**

6.4.1 BellSouth liability for such unbillables shall be limited to instances of error or omission, including but not limited to, the acts or omissions of BellSouth employees, agents and contractors, and the failures of BellSouth hardware, software and other BellSouth equipment. BellSouth's liability to Interprise America shall be limited to the net loss to Interprise America.

6.4.2 The term "unbillable" refers to a message or service that cannot be billed to the correct Interprise America customer.

6.4.3 BellSouth shall include Unbillables as a result of Recording Failure, or Lost, Damaged, or Destroyed Data on the monthly billing statement.

7. **DELETED**

8. **Local Account Maintenance**

8.1 When Interprise America purchases Local Service from BellSouth, and, as appropriate, when Interprise America purchases certain Unbundled Network Elements, BellSouth shall provide Interprise America with Local Account Maintenance as described herein. These procedures are in

addition to Service Order procedures set forth in Part I and Attachment 4 to the Agreement.

- 8.2 When notified by a CLEC that an Interprise America Customer has switched to CLEC service, BellSouth shall provision the change, and notify Interprise America via CONNECT:Direct that the customer has changed to another service provider ("OUTPLOC").
- 8.3 When notified by Interprise America that a customer has changed his/her PIC only from one interexchange carrier to another carrier, BellSouth shall provision the PIC only change and convey the confirmation of the PIC change via the work order completion feed.
- 8.4 If notified by an interexchange carrier using an '01' PIC order record that a Interprise America Customer has changed his/her PIC only, BellSouth will reject the order and notify that interexchange carrier that a CARE PIC record should be sent to the serving CLEC for processing.

9. InterCompany, Intra-BellSouth Region Settlements

- 9.1 The parties agree that intraLATA and local alternatively billed messages shall be billed and revenues retained by the billing party until the implementation of the Non-InterCompany Settlement System ("NICS"). Implementation of NICS is expected fourth quarter of 1997.
- 9.2 Subsequent to the implementation of NICS, both parties agree to provide input into NICS that is necessary to produce the appropriate settlement reports. BellSouth agrees to be a party to the NICS contract with the host Regional Bell Operating Company.
- 9.2.1 Message Types Subject to the Services

Interprise America will provide the Incollect Services only for the types of messages identified on Subappendix G to this Attachment 7 (collectively, "Messages").

9.2.2 Pack Failures/Data Retention

BellSouth shall notify Interprise America of any transmission failure within 24 hours. BellSouth shall correct and retransmit to Interprise America any such packs within 24 hours. If message packs are retransmitted for any reason, including, but not limited to, a reject of the packs, damage in transit, dataset naming failures, or similar reasons, if caused by BellSouth, then BellSouth shall assume the expense of replacement unless the need for replacement is caused by Interprise America's act or omission. BellSouth agrees to retain copies of all message packs transmitted to Interprise America for omission. BellSouth agrees to retain copies of all

message packs transmitted to Interprise America for minimum of forty-five (45) calendar days of the date of original transmission.

9.2.3 Message Return Policy

BellSouth will receive messages returned from Interprise America that cannot be billed and the appropriate standard field and values on the EMR records will be populated.

9.2.4 Purchase of Messages

Interprise America will purchase rated messages from BellSouth at the purchase of accounts receivable rates ("PARS rates") set forth in Subappendix H of this Attachment 7 and will be net of the billing and collection rates also set forth in Subappendix H. BellSouth shall provide Interprise America with a monthly statement for messages BellSouth transmitted to Interprise America for purchase (including returned messages transmitted back to BellSouth as unbillable).

The monthly statement provided by BellSouth shall list the following items:

- number of incollect messages purchased
- number of incollect unbillable messages returned
- + message revenue purchased
- + state taxes associated with purchased messages
- + local taxes associated with purchased messages
- + federal taxes associated with purchased messages
- unbillable returned message revenue
- state taxes associated with unbillable returned messages
- local taxes associated with unbillable returned messages
- federal taxes associated with unbillable returned messages
- billing charges (net number of incollect messages purchased/
returned times B&C rate; B&C should not be applicable if
purchased messages were returned)

TOTAL AMOUNT DUE BELLSOUTH

BellSouth shall provide Interprise America with a monthly intraregion settlement report to support the monthly statement. The monthly statement and settlement report shall reflect messages processed for purchasing from 26th to 25th of each month. BellSouth shall deliver to Interprise America the monthly statement and settlement report on or

before the fifteenth calendar day month immediately following the month in which messages were purchased (including returned messages).

BellSouth shall send monthly statement and settlement report to:

Interprise America - National Expansion Accounts Payable
Attn: Billing Manager
1999 Broadway
7th Floor
Denver, CO 80202

Interprise America shall pay BellSouth via check or wire on or before last business day of the billing statement month (e.g. service month - 4/96, billing month = 5/15/96, payment due date = 5/31/96.)

If the Payment Due Date falls on a Saturday or a bank holiday that is observed on a Tuesday, Wednesday, Thursday or Friday, then the Payment Due Date shall be the last non-holiday day preceding such Saturday or holiday. If the Payment Due Date falls on a Sunday or a bank holiday that is observed on a Monday, then the Payment Due Date shall be the first non-holiday following such Sunday or holiday. Interprise America shall pay BellSouth a late payment charge calculated based on the lesser of (i) one and one-half percent (1 1/2%) or (ii) the highest interest rate (in decimal value) which may be charged by law for commercial transactions on all payments received after the due date.

9.2.5 Taxes

BellSouth shall be solely responsible for calculation of all applicable sales, excise, taxes, and surcharges on the Messages purchased by Interprise America to the appropriate jurisdiction. BellSouth will indicate the tax to be billed to the end user customer on the messages sent to Interprise America for billing. FET will be calculated by Interprise America but will be BellSouth's responsibility to remit. BellSouth shall file all returns for taxes imposed on, or with respect to messages sold by BellSouth. BellSouth agrees to hold Interprise America harmless from and against any liability or loss resulting from any tax, charge, interest, additions to tax, surcharges or other charges payable or incurred by Interprise America as a result of BellSouth's failure or error in calculating tax as described in this section.

9.3 Outcollect Services

BellSouth shall purchase rated Outcollect Messages and provide message collection and distribution on behalf of Interprise America for intraLATA collect, calling card and third number billed messages. For Intraregion non-ICS messages, the billing company is responsible for billing these messages. The Messages will be received through CMDS. BellSouth shall forward such Messages at agreed upon intervals to Interprise America. Interprise America will notify BellSouth of any changes to Subappendix I to this Attachment 7 within thirty (30) days of the effective

date of such change. Both Interprise America and BellSouth must mutually agree to this change.

9.3.1 Message Types Subject to the Services

BellSouth will provide the Services only for the types of messages identified on Subappendix J (collectively, "Messages"). BellSouth will purchase and forward the messages to Interprise America subject to the provisions of Section 9.3 preceding.

9.3.2 Pack Failures/Data Retention

Interprise America shall notify BellSouth of any transmission failures within 24 hours. Interprise America shall correct and retransmit to BellSouth any such packs within 24 hours. If message packs are retransmitted for any reason including but not limited to a reject of the packs, damage in transit, dataset naming failures, or similar reasons, if caused by Interprise America, then Interprise America shall assume the expense of replacement unless the need for replacement is caused by BellSouth or omission. Interprise America agrees to retain copies of all message packs transmitted to BellSouth for minimum of forty-five (45) calendar days of the date of original transmission.

9.3.3 Message Return Policy

Interprise America will receive messages returned from BellSouth that cannot be billed and the appropriate standard field and values on the EMR records will be populated.

9.3.4 Purchase of Messages

BellSouth will purchase messages from Interprise America at the purchase of accounts receivable rates ("PARS rates") set forth in Subappendix K ("PARS rates") and will be net of the billing and collection rates also set forth on Subappendix K to this Attachment. Interprise America shall provide BellSouth with a monthly statement for messages Interprise America transmitted to BellSouth via CMDS for purchase (including returned messages transmitted back to Interprise America via CMDS as unbillable.)

Monthly statement provided by Interprise America shall list the following items:

number of outcollect messages purchased
number of outcollect unbillable messages returned
+ message revenue purchased
+ state taxes associated with purchased messages
+ local taxes associated with purchased messages
+ federal taxes associated with purchased messages
- unbillable returned messages revenue
- state taxes associated with unbillable returned messages

- local taxes associated with unbillable returned messages
- federal taxes associated with unbillable returned messages
- billing charges (net number of outcollect messages purchased/returned times B&C rate; B&C should not be applicable if purchased messages were returned)

TOTAL AMOUNT DUE Interprise America

Interprise America shall provide BellSouth with a monthly intraregion settlement report to support the monthly statement. Monthly statement and settlement report shall reflect messages processed through the intraregion settlement system from 26th to 25th of each month. Interprise America shall deliver to BellSouth the monthly statement and settlement report on or before the fifteenth calendar day of the month immediately following the month in which messages were purchased (including returned messages). Interprise America shall send monthly statement and settlement report to:

[BELLSOUTH TO PROVIDE]

BellSouth shall pay Interprise America via wire or check on or before the last business day of the billing statement month (e.g. service month - 4/96, billing statement date - 5/15/96, payment due date = 5/31/96.)

If the Payment Due Date falls on a Saturday or a bank holiday that is observed on a Tuesday, Wednesday, Thursday, or Friday, then the Payment Due Date shall be the last non-holiday day preceding such Saturday or holiday. If the Payment Due Date falls on a Sunday or a bank holiday that is observed on a Monday, then the Payment Due Date shall be the first non-holiday following such Sunday or holiday.

Interprise America shall pay BellSouth a late payment charge calculated based on the lesser of (i) one and one-half percent (1 1/2%) or (ii) the highest interest rate (in decimal value) which may be charged by law for commercial transactions on all payments received after the due date.

9.3.5 Taxes

Interprise America shall be solely responsible for calculation of all applicable sales, excise, taxes, and surcharges on the Messages purchased by BellSouth to the appropriate jurisdiction. Interprise America will indicate the tax to be billed to the end user customer on the message sent to BellSouth for billing. BellSouth will use the tax on the message for customer billing. FET will be calculated by BellSouth but will be Interprise

America's responsibility to remit. Interprise America shall file all returns for taxes imposed on, or with respect to messages sold by Interprise America. Interprise America agrees to hold BellSouth harmless from and against any liability or loss resulting from any tax, charge, interest, additions to tax, surcharges or other charges payable or incurred by BellSouth as a result of Interprise America's failure or error in calculating tax as described in this section of the Agreement.

9.4 **Settlement of Disputed Amounts and Claims/Escalation Procedures**

If either Party disputes any portion of the Amount Due, said Party shall notify the other Party in writing of the nature and basis of the dispute. Either Party may file a substantiated claim with the other Party for billing and collection charges and/or billed revenue. If the dispute is not resolved by the Payment Date, the claiming Party shall pay all undisputed amounts, but is not obligated to pay the disputed amount. If a Party has paid an amount which it subsequently chooses to dispute, that Party shall not be authorized or permitted to reduce amount owed on subsequent bills or statements or in any way offset against such owed amounts the amount being claimed. The Party receiving the claim shall have thirty (30) days from the notification date, or other mutually agreed upon period, to process the claim and notify the claiming Party of the claim status. If the claim, in whole or part, is ultimately resolved in favor of the claimant, the claiming Party shall be entitled to refund or a credit. After written notice to the claiming Party that the claim has been sustained, the total amount of the refund or credit, shall be remitted no later than thirty-one (31) calendar days following resolution. Both Parties shall retain such detailed information as may reasonably be required for resolution of the disputed amount during the pendency of the dispute. No claims may be made more than two (2) year after the date of the event that gave rise to the claim.

In the event that any dispute cannot be resolved under this Section 9.4, the Parties shall follow the provisions set forth in Section 15 of the General Terms and Conditions of the Agreement.

9.5 **Industry Standards**

The provisions set forth in this Section 9 are intended to cover incollect/out collect procedures until industry standards are adopted. If such standards are adopted, and both Parties agree on such standards, the Parties agree to review these procedures and amend these procedures as appropriate.

**APPENDIX I
TO
ATTACHMENT 7 - DELETED**

**APPENDIX II
TO
ATTACHMENT 7**

CUSTOMER USAGE DATA

TRANSFER REQUIREMENTS

SECTION I: SCOPE

1. General

This Appendix addresses the transmission by a BellSouth of Interprise America Customer usage to Interprise America.

2. Usage Summary

Messages will be transmitted, via a direct feed, to Interprise America in standard EMR format.

The following is a list of EMR records that Interprise America can expect to receive from BellSouth:

Header Record 20-20-01

Trailer Record 20-20-02

Detail Records* 01-01-01, 06, 07, 08, 09, 16, 18, 31, 32, 33, 35, 37, 80, 81, 82, 83

10-01-01, 06, 07, 08, 09, 16, 18, 31, 32, 35, 37, 80, 81, 82, 83

Credit Records 03-01-XX

Rated Credits 41-01-XX

Cancel Records 51-01-XX 58-01-XX (Where the Record Being Cancelled is Unrated.)

Correction Records 71-01-XX

*Category 01 is utilized for Rated Messages; Category 10 is utilized for Unrated Messages

In response to changes in EMR records, BellSouth shall provide at least 90 days notice to Interprise America regarding the modifications of or addition of records.

In addition, BellSouth shall provide a 42-50-01 Miscellaneous Charge record to support the Special Features Star Services (see Subappendix F for specific details) if these features are part of BellSouth's offering. For detailed information regarding EMR, refer to the current version of the BellCore Practice BR010-200-010. The Parties shall mutually agree on record types used for all usage and service types.

3. Appendix Content

This Appendix describes baseline requirements for the transfer of BellSouth recorded, unrated usage to Interprise America. Testing requirements and the reports needed to ensure data integrity are also included. Additional requirements and implementation details may be identified for conditions unique to BellSouth. Modifications and/or exceptions to this Appendix must be negotiated and mutually agreed upon by BellSouth and Interprise America.

SECTION II: RECORDED USAGE TO BE TRANSMITTED TO INTERPRISE AMERICA

1. **General**

This section addresses the types of usage to be transmitted by BellSouth to Interprise America.

2. **Usage To Be Transferred To Interprise America**

2.1 **Interprise America Usage To Be Transferred**

The following messages recorded by BellSouth are to be transmitted to Interprise America. BellSouth recorded usage includes all usage by Interprise America Customers.

NOTE: Rated incollect messages should be transmitted via the direct feed and can be intermingled with the unrated messages. No special packing is needed.

2.1.1 The Parties agree that if any of the above mentioned messages cannot be rated and/or billed by Interprise America, BellSouth will work diligently and in good faith with Interprise America to determine the cause of the problem and will work to expeditiously resolve the defect. Upon the execution of this Agreement, BellSouth will provide Interprise America with a contact name and number for the resolution of any problems that may arise under this subsection. The Parties further agree that if the number of problems that occur are de minimus, the process described in this subsection may be extended for the time period agreed to by the Parties. BellSouth to provide MIC manager name and number.

2.2 File transfer specifications are included within Section III of this Appendix II.

3. **Interprise America Usage**

For all Recorded Usage Data provided by BellSouth to Interprise America, such Recorded Usage Data in a local resale environment shall include all intraLATA toll and local usage. BellSouth will provide Interprise America with unrated EMR records associated with all intraLATA toll and local usage which they record on Interprise America's behalf. Any Category, Group and/or Record types approved in the future for BellSouth will be included if they fall within the definition of local service resale. Interprise America shall be given

notification of implementation of a new type within the negotiated timeframes.
NOTE: BellSouth messages will be packed using the packing criteria outlined in Section III. 4.8 of this Appendix. It is important to note that all BellSouth messages will be packed together (intermingled) based on the appropriate !nterprise America Send To/Bill To RAO combination. Specific categories, groups, and record types will not be packed separately.

SECTION III: BELLSOUTH TO INTERPRISE AMERICA USAGE FEED

1. **General**

This section contains the information required for BellSouth to transmit to Interprise America the usage defined in this Appendix, Section II. This section specifically addresses the dataset requirements and processing.

2. **Detailed EMR Record Edits**

Interprise America will perform detailed record edits on the unrated and rated messages upon receipt from BellSouth. See Appendix II, Section II, Paragraph 2.1.1.

3. **Duplicate Record Checks**

Interprise America will perform record checks on the unrated and rated messages to validate that duplicate messages are not sent by BellSouth to Interprise America.

4. **BellSouth to Interprise America Usage Feed**

4.1 **DELETED**

4.2 **Physical Characteristics**

Data transported to Interprise America via CONNECT:Direct. The parties will agree upon the necessary information to initiate CONNECT:Direct transmission capabilities.

4.3 **Data Delivery Schedules**

Data will be delivered to Interprise America by BellSouth daily (Monday through Friday) unless otherwise negotiated and agreed to in writing by both Parties. Interprise America and/or BellSouth Data Center holidays are excluded. BellSouth and Interprise America will exchange schedules of designated Data Center holidays.

4.4 **Resending Data**

Interprise America will notify BellSouth of resend requirements if a pack or entire dataset must be replaced due to pack rejection, damage in transit, dataset name failure, etc.

4.5 Pack Rejection

Critical edit failure on the Pack Header or Pack Trailer records will result in pack rejection (e.g., detail record count not equal to grand total included in the pack trailer). Notification of pack rejection will be made by Interprise America within one (1) business day of processing. Rejected packs will be corrected by BellSouth and retransmitted to Interprise America by BellSouth.

4.6 Held Packs And Messages

Interprise America and BellSouth will track pack number to control input based upon invoice sequencing criteria. BellSouth will be notified of sequence failures identified by Interprise America and resend procedures are to be invoked if requested by Interprise America.

4.7 Data Content Requirements

EMR is the format to be used for usage data provided to Interprise America.

RAO Packing Requirements

A pack shall contain a minimum of one message record or a maximum of 9,999 message records plus a pack header record and a pack trailer record. A file transmission contains a maximum of 99 packs. A dataset shall contain a minimum of one pack. BellSouth will provide Interprise America one dataset per sending location, with the agreed upon RAO/OCN populated in the Header and Trailer records.

Within the Header and Trailer records, the FROM RAO identifies the location that will be sending usage to Interprise America. BellSouth will populate the FROM RAO field with the unique numeric value identifying the location that is sending the data to Interprise America. BellSouth will populate the Send To/Bill To RAO fields with the appropriate Interprise America RAO values. Also, Pack Header and Trailer will have the OCN appropriately populated.

The FROM RAO, OCN will be used by Interprise America to control invoice sequencing and each will have its own invoice controls.

The file's Record Format (RECFM) will be Variable Block (VB) Size 2,476 and the Logical Record Length (LRECL) will be 2,472 bytes.

Interprise America has no special sort requirements for the packs sent by BellSouth.

4.8 Dataset Naming Convention

BellSouth will transmit the usage to Interprise America using the following dataset naming conventions. The dataset name (DSN) will be partitioned into five nodes, separated by periods as follows:

NODE 1BB3PXNN*
 NODE 2.IBMUP
 NODE 3 (To be determined during negotiations)
 NODE 4.USAGE

NODE 5.GNNNNV* (Generational Dataset to be incremented by sender).
 *The italicized "N" represents numeric fields determined during negotiations.

4.10 Confirmation Record

Interprise America shall provide a confirmation record for each pack, using Interprise America defined fields at BellSouth's request. An example of the confirmation record, which may be modified at Interprise America's need follows.

Following is a layout of the Confirmation Record that Interprise America will create for each pack. It may be modified as needed by Interprise America.

Field Name	Field Position	Field Length	Notes
Category	01-02	x(2)	Value: "RI"
Group	03-04	x(2)	Value: "PC"
Record Type	05-06	x(2)	Value: "03" (i.e., zero-three)
Date Created - Year	07-08	9(2)	
Date Created - Month	09-10	9(2)	
Date Created - Day	11-12	9(2)	
Invoice Number	13-14	9(2)	
Filler	15-16	9(2)	Zeroes
From RAO	17-19	9(3)	
Send To RAO	20-22	9(3)	
Billing RAO	23-25	9(3)	
Operating Company	26-29	9(4)	

Number			
Filler	30-65	9(36)	
Total Sent Messages	66-72	9(7)	
Total Sent Revenue	73-82	9(8).99	
Number of Accepted Messages	83-89	9(7)	
Amount of Accepted Revenue	90-99	9(8).99	
Filler	100	9(1)	
Number of Rejected Messages	101-107	9(7)	
Amount of Rejected Revenue	108-117	9(8).99	
Filler	118-137	9(20)	Zeroes
Pack Status Code	138-139	9(2)	
Return Code 1	140-141	x(2)	
Return Code 2	142-143	x(2)	
Return Code 3	144-145	x(2)	
Return Code 4	146-147	x(2)	
Return Code 5	148-149	x(2)	
Return Code 6	150-151	x(2)	
Return Code 7	152-153	x(2)	
Return Code 8	154-155	x(2)	
Return Code 9	156-157	x(2)	
Return Code 10	158-159	x(2)	
Filler	160-175	x(16)	Zeroes

SECTION IV: INTERPRISE AMERICA PROCESSING REQUIREMENTS

1. **General**

This section contains requirements for Interprise America processing of Recorded Usage Data that has been transmitted to Interprise America for billing.

2. **Interprise America Rating Process**

2.1 **Message Rating**

Interprise America will rate any individual messages (as defined in Section II of this Appendix), that have not already been rated by BellSouth, prior to transmitting the usage to a billing environment within Interprise America.

2.2 **Application Of Taxes/Fees/Surcharges**

Interprise America will apply taxes, fees and surcharges as appropriate for the individual messages and/or customer accounts. The application of all taxes, fees and surcharges will be applied on all intraLATA local and toll usage received from BellSouth.

2.3 **Duplicate Messages**

Interprise America has existing duplicate checks as part of their message processing or billing functions. Interprise America will perform these checks on the rated/unrated messages sent pursuant to BellSouth duplicate message disposition procedures and reports will be identified by Interprise America during negotiations.

2.4 **Record Edits**

2.4.1 **Interprise America Record Edits**

See Appendix II, Section II, Paragraph 2.1.1. Interprise America will perform detailed record edits on the rated and unrated messages prior to transmitting them to the billing environment. BellSouth will work proactively with Interprise America to resolve any error conditions and the prevention of errors.

2.4.2 **BellSouth Record Edits**

If BellSouth has existing detailed record edits for rated and unrated messages, BellSouth is to perform these edits.

See Appendix II, Section II, Paragraph 2.1.1

2.4.3 Interprise America To BellSouth Message Returns

See Appendix II, Section II, Paragraph 2.1.1. [At the discretion of Interprise America, messages that have been sent to Interprise America by BellSouth that cannot be guided to an Interprise America billed account or error in processing will be returned to BellSouth with the appropriate negotiated return codes as provided in this Appendix, Section II. 2.1 and Section II. 2.1.1.]

2.4.4 Cancel/Correction Records

Interprise America, upon receipt of cancel/correction records, will perform their current matching functionality to identify the original message to be canceled/corrected. (Processing will be dependent upon individual negotiations.)

SECTION V: TEST PLANS AND ACTIVITIES

1. **General**

This section defines BellSouth and Interprise America activities which are required prior to implementation. The tests and activities described are necessary to ensure a smooth, accurate and well-programmed conversion. Specific test dates will be identified through the negotiations process.

2. **Interface Testing**

The purpose of this test is to ensure that the usage described in Section II of this Appendix preceding can be sent by BellSouth to Interprise America and can be accepted and processed by Interprise America. BellSouth will provide a test file to Interprise America's designated Regional Processing Center (RPC) in the format that will be used for live day-to-day processing. The file will contain that production Data Usage that Interprise America and BST agree upon. The format of the file will conform to the requirements shown in Section III. Interprise America will review the file and verify that it conforms to its data center requirements. Interprise America will notify BellSouth in writing whether the format is acceptable. Interprise America will also provide BellSouth with the agreed-upon control reports as part of this test.

3. **Operational Test**

The purpose of this test is to ensure that volumes of usage in consecutive sequence can be extracted, distributed, and processed by BellSouth and Interprise America.

BellSouth is required to provide Interprise America with BellSouth recorded, unrated usage (as defined in Section II of this Appendix) for a minimum of five (5) consecutive days. Interprise America will provide BellSouth with the message validation reports associated with test usage.

Interprise America will rate and process the unrated intraLATA toll and local usage. Interprise America will process this data to test bills. Interprise America may request that the test usage contain specific usage volumes and characteristics to ensure a complete test. Specific usage volumes and characteristics will be discussed during detailed negotiations. To the extent that Interprise America wishes to request specific usage volumes and characteristics for test data, Interprise America will need to establish actual accounts with BellSouth, and place test calls to be collected for inclusion in the tests.

4. **Test File**

Test data should be transported via CONNECT:Direct whenever possible. In the event that courier service must be used to transport test media, the physical tape characteristics to be used are described in Subappendix A hereto.

SECTION VI: POST DEPLOYMENT ACTIVITIES

1. **General**

Requirements for ongoing maintenance of the usage feeds between Interprise America and BellSouth are described in this section. Included are minimal requirements for day to day control of the regularly scheduled transfer of BellSouth unrated and rated usage data and procedures for introducing and verifying Interprise America/BellSouth System Changes.

2. **Control Maintenance And Review**

2.1 **Periodic Review**

Control procedures for all usage transferred between BellSouth and Interprise America will require periodic review. This review may be included as part of an annual audit of BellSouth by Interprise America or as part of the normal production interface management function. Breakdowns which impact the flow of usage between BellSouth and Interprise America must be identified and jointly resolved as they occur. The resolution may include changes to control procedures, as similar problems would be avoided in the future. Any changes to control procedures would need to be mutually agreed upon by Interprise America and BellSouth.

2.2 **Retention of Records**

BellSouth shall maintain a machine readable back-up copy of the message detail provided to Interprise America for a minimum of forty-five (45) calendar days. Interprise America will maintain the message detail received from BellSouth for a minimum period of forty-five (45) calendar days. Designated Interprise America personnel will provide these records to BellSouth or its authorized agents upon written request. BellSouth will also provide any data back to Interprise America upon their written request.

3. **BellSouth Software Changes**

When BellSouth plans to introduce any software changes which impact the format or content structure of the usage data feed to Interprise America, designated BellSouth personnel will notify Interprise America no less than one hundred twenty (120) calendar days before such changes are implemented.

BellSouth will communicate the projected changes to the appropriate groups in Interprise America so that potential impacts on Interprise America processing can be determined.

Interprise America personnel will review the impact of the change on the entire control structure as described in Appendix II Section 5, Post Conversion Test Plan, herein. Interprise America will negotiate any perceived problems with BellSouth and will arrange to have the data tested utilizing the modified software.

If it is necessary for BellSouth to request changes in the schedule, content or format of usage data transmitted to Interprise America, BellSouth will notify Interprise America.

3.1 **Interprise America Requested Changes**

If it is necessary for Interprise America to request changes in the schedule, content, or format of the usage data transmitted from BellSouth, Interprise America will notify BellSouth.

When the negotiated changes are to be implemented, Interprise America and/or BellSouth will arrange for testing of the modified data as described in Appendix II, Section 5, Post Conversion Test Plan.

4. **Interprise America Software Changes**

When Interprise America plans to introduce any software changes which may impact the format or content structure of the usage data transmitted from BellSouth, Interprise America will notify the designated BellSouth personnel, no less than one hundred twenty (120) calendar days before such changes are implemented.

The Interprise America contact will communicate the projected changes to the appropriate groups in BellSouth so that potential impacts on BellSouth processing can be determined.

Interprise America will negotiate any perceived problems with BellSouth and will arrange to have the data tested utilizing the modified software.

Altering the one hundred twenty (120) day window for introducing software changes can be negotiated by both companies, dependent upon the scope and impact of the change.

5. **Post-Conversion Test Plan**

The test plan described below is designed to encompass all types of changes to the usage data transferred by BellSouth to Interprise America and the methods of transmission for that data.

5.1 **BellSouth System Change Description**

For a BellSouth system change, BellSouth shall provide Interprise America with an overall description of the change, stating the objective and a brief explanation of the reasons for the change.

During the initial negotiations regarding the change, BellSouth shall provide a list of the specific records and/or systems impacted by the change to designated Interprise America personnel.

Finally, BellSouth shall also provide Interprise America a detailed description of the changes to be implemented. It shall include sufficient detail for designated Interprise America personnel to analyze and estimate the effects of the changes and to design tests to verify the accuracy of the implementation.

5.2 **Change Negotiations**

Interprise America shall be notified in writing of all proposed negotiations initiated by BellSouth. In turn, Interprise America will notify BellSouth of proposed change negotiations initiated by Interprise America.

After formal notification of planned changes, whether originated by BellSouth or Interprise America, designated Interprise America personnel will schedule negotiation meetings as required with designated BellSouth personnel. The first meeting should produce the overall change description (if not previously furnished) and the list of records and/or systems affected.

In subsequent meetings, BellSouth shall provide the detailed description of changes to be implemented. After reviewing the described changes, designated Interprise America personnel will negotiate a detailed test procedure with BellSouth.

5.3 **Control Change Analysis**

Based on the detailed description of the changes provided by BellSouth, and the review of the projected changes by Interprise America, designated Interprise America personnel will:

- 5.3.1 Determine the impact of the changes on the overall structure.
- 5.3.2 Determine whether any single change has a potential control impact (i.e., high error rate on individual records that might result in pack rejection);
- 5.3.3 Determine whether any controls might be adversely affected; and
- 5.3.4 Arrange for appropriate control structure changes to meet any of the above conditions.

5.4 **Verification Of Changes**

- 5.4.1 Based on the detailed description of changes furnished by BellSouth, designated Interprise America personnel will:
 - 5.4.1.1 Determine the type of change(s) to be implemented.
 - 5.4.1.2 Develop a comprehensive test plan.
 - 5.4.1.3 Negotiate scheduling and transfer of modified data with BellSouth.
 - 5.4.1.4 Negotiate testing of modified data with the appropriate Interprise America RPC.
 - 5.4.1.5 Negotiate processing of verified data through the Interprise America billing system with the RPC.
 - 5.4.1.6 Arrange for review and verification of testing with appropriate Interprise America groups.
 - 5.4.1.7 Arrange for review of modified controls, if applicable.

5.5 **Introduction of Changes**

- 5.5.1 When all the testing requirements have been met and the results reviewed and accepted, designated Interprise America personnel will:
 - 5.5.1.1 Negotiate an implementation schedule.
 - 5.5.1.2 Verify the existence of a contingency plan with the appropriate Interprise America personnel.
 - 5.5.1.3 Arrange for the follow-up review of changes with appropriate Interprise America personnel.
 - 5.5.1.4 Arrange for appropriate changes in control program, if applicable.
 - 5.5.1.5 Arrange for long-term functional review of impact of changes on the Interprise America billing system, i.e., accuracy, timeliness, and completeness.

SECTION VII: SUBAPPENDICES

SUMMARY OF SUBAPPENDICES

Subappendix A

Deleted

Subappendix B

DELETED

Subappendix C

DELETED

Subappendix D

DELETED

Subappendix E

DELETED

Subappendix F

Special Features Star Services

Subappendix G

Types or Messages

Subappendix H

Subappendix I

Subappendix J

Subappendix K

SUBAPPENDIX A

DELETED

SUBAPPENDIX B

DELETED

SUBAPPENDIX C

DELETED

SUBAPPENDIX D

DELETED

Enterprise America - KY

9/15/97

**SUBAPPENDIX F
SPECIAL FEATURES STAR SERVICES**

The following are STAR Services supported by these Local Resale requirements to date. When identified, additional services can be negotiated to be included in this Resale offer.

- 1) Busy Redial/.....
Last Number Redial This feature allows a customer to redial a number when a Busy signal is encountered.
- 2) Call Return/Missed Call Dialing..... This feature allows a customer to automatically return the most recent incoming call, even if it is not answered.
- 3) Call Trace This feature allows the tracing of nuisance calls.
- 4) 3-Way Calling..... This feature allows for three (3) Parties to communicate on one line.
- 5) Automatic Redial..... This feature allows a customer to automatically redial the last number dialed.

To provide for the transfer and billing of these features the following requirements apply:

For all "per use" STAR Features the 'Miscellaneous Charge Line Summary Non-Detail Charge' 425001 record should be used and be populated as follows:

CONNECT TIME	POSITIONS 55 - 60	MUST BE POPULATED
MISCELLANEOUS TEXT CODE	POSITIONS 168 - 172	1) BUSY REDIAL/LAST NUMBER REDIAL POPULATE WITH '00001'
MISCELLANEOUS *TEXT CODE	POSITIONS 168 - 172	2) CALL RETURN/LAST NUMBER REDIAL POPULATE WITH '00002'
MISCELLANEOUS TEXT CODE	POSITIONS 168 - 172	3) CALL TRACE POPULATE WITH '00003'
MISCELLANEOUS TEXT CODE	POSITIONS 168-172	4) 3-WAY CALLING POPULATE WITH '00004'
MISCELLANEOUS TEXT CODE	POSITIONS 168-172	5) AUTOMATIC REDIAL POPULATE WITH '00005'

NOTE: For fields not specifically defined, the standard EMR format for a 425001 record should be used.

SUBAPPENDIX E

DELETED

SUBAPPENDIX G

Subappendix G sets forth the types of messages for which Interprise America will provide the Services.

INTRALATA LOCAL AND TOLL COLLECT

INTRALATA LOCAL AND TOLL BILLED TO THIRD NUMBER

INTRALATA LOCAL AND TOLL CALLING CARD

SUBAPPENDIX H

PURCHASE OF ACCOUNTS RECEIVABLE RATE: 100%

BILLING AND COLLECTIONS RATES: .05 per message

SUBAPPENDIX I

Subappendix I sets forth the Carrier from which BellSouth will buy messages:

Interprise America

SUBAPPENDIX J

MESSAGES

Subappendix J sets forth the types of messages for which BellSouth will provide the Services.

LOCAL INTRAREGION AND TOLL COLLECT

LOCAL INTRAREGION AND TOLL BILLED TO THIRD NUMBER

LOCAL INTRAREGION AND TOLL CALLING CARD

SUBAPPENDIX K

RATES

PURCHASE OF ACCOUNTS RECEIVABLE RATE: 100%

BILLING AND COLLECTIONS RATES: .05 per message

TABLE OF CONTENTS

	<u>PAGE</u>
LOCAL NUMBER PORTABILITY	
1. BellSouth Provision of Local Number Portability.....	1
2. Interim Number Portability (INP).....	1
3. Permanent Number Portability (PNP).....	3
4. Requirements for INP and PNP.....	4

LOCAL NUMBER PORTABILITY

1. BellSouth Provision of Local Number Portability

BellSouth shall provide number portability in accordance with requirements of the Act. Interim Number Portability (INP) will be provided by BellSouth to Interprise America, immediately upon the Effective Date of this Agreement. INP will be provided with minimum impairment of functionality, quality, reliability and convenience to subscribers of Interprise America services. BellSouth will provide PNP as soon as it is technically feasible, in conformance with FCC rules and the Act and the Georgia Public Service Commission in Docket No. 5840-U.

1.A Interprise America Provision of Local Number Portability

Upon request by BellSouth, Interprise America shall provide number portability in accordance with the requirements of the Act. BellSouth and Interprise America shall negotiate in good faith Interprise America's provisions of INP to BellSouth consistent with BellSouth's actual requirements and Interprise America's technical capabilities.

2. Interim Number Portability (INP)

INP shall be provided by Remote Call Forwarding ("RCF"), Route Indexing, or Local Exchange Routing Guide (LERG) reassignment. In addition to providing RCF, BellSouth agrees to provide Route Indexing and LERG reassignment in every local service office. Interprise America shall specify on a per telephone number basis which method is to be employed and BellSouth shall provide such method to the extent technically feasible.

2.1 Remote Call Forwarding

Remote Call Forwarding (RCF) is an existing switch-based BellSouth service that may be used to provide subscribers with limited service-provider LNP by redirecting calls within the telephone network. When RCF is used to provide LNP, calls to the ported number will first route to the BellSouth switch to which the ported number was previously assigned. The BellSouth switch will then forward the call to a number with an NXX associated with the Interprise America operated switch to which the number is ported. Interprise America shall be required to order, additional paths to handle multiple simultaneous calls to the same ported telephone number.

2.2 **Route Indexing**

Route Indexing (RI) may take two forms: Route Index-Portability Hub (RI-PH) or Directory Number-Route Index (DN-RI).

- 2.2.1 RI-PH will route a dialed call to the BellSouth switch associated with the NXX of the dialed number. The BellSouth switch shall then insert a prefix onto the dialed number which identifies how the call is to be routed to Interprise America as the local service provider. The prefixed dialed number is transmitted to the BellSouth tandem switch to which Interprise America is connected. The prefix is removed by the operation of the tandem switch and the dialed number is routed to Interprise America's switch so the routing of the call can be completed by Interprise America.
- 2.2.2 DN-RI is a form of RI-PH that requires direct trunking between the BellSouth switch to which the ported number was originally assigned and the Interprise America switch to which the number has been ported. The BellSouth switch shall send the originally dialed number to the Interprise America switch without a prefix.
- 2.2.3 BellSouth shall provide RI-PH or DN-RI on an individual telephone number basis, as Interprise America designates. Where technically feasible, Interprise America may designate both methods so that calls to ported numbers are first directed to the Interprise America switch over direct trunks but may overflow to tandem trunks if all trunks in the direct group are occupied.
- 2.2.4 For both RI-PH and DN-RI the trunks used may, at Interprise America's option, and where technically feasible, be the same as those used for exchange of other local traffic and intraLATA toll traffic with BellSouth. At Interprise America's option, the trunks shall employ SS7 or in band signaling.

2.3 **LERG Reassignment**

Portability for an entire NXX: Local Exchange Routing Guide (LERG). reassignment of an entire NXX can be via per occasion agreements among BellSouth, Interprise America and the LERG administrators. Updates to translations in the BellSouth switching office from which the telephone number is ported will be made by BellSouth prior to the date on which LERG changes become effective, in order to redirect calls to the Interprise America switch via route indexing.

2.4 **Other Interim Portability Provisions**

- 2.4.1 BellSouth shall exchange with Interprise America, SS7 TCAP messages as required for the implementation of Custom Local Area Signaling Services (CLASS) or other features available in the BellSouth network.
- 2.4.2 BellSouth shall notify Interprise America of any technical or capacity limitations that would prevent use of a requested interim LNP implementation in a particular switching office. BellSouth and Interprise America shall cooperate in the process of porting numbers to minimize customer out-of-service time.
- 2.4.2.1 For a coordinated cutover environment (where the loop is being purchased by Interprise America as an unbundled network element at the time of INP implementation), BellSouth shall update switch translations, where necessary, as close to the requested time as possible, using best efforts not to exceed thirty (30) minutes after the physical cutover is completed.
- 2.4.2.2 For a non-coordinated cutover environment (where the loop is supplied by Interprise America), BellSouth shall schedule a mechanized update of switch translations at the Interprise America requested cutover time (frame due time). In the event that Interprise America requires a change to the requested cutover time, Interprise America shall notify the BellSouth Local Carrier Service Center a minimum of three (3) hours prior to the frame due time to arrange for a new frame due time. BellSouth shall update switch translations where necessary as close to the requested time as possible, using best efforts not to exceed thirty (30) minutes after the physical cutover is completed.
- 2.4.3 Interprise America shall have the right to use the existing BellSouth 911 infrastructure for all 911 capabilities. With respect to 911 service associated with ported numbers under INP, BellSouth agrees that all ported directory numbers (DN) will remain in the Public Service Answering Points (PSAP) routing databases. When RCF is used, both the ported numbers and shadow numbers for Interprise America ported subscribers shall be stored in PSAP databases. Interprise America shall have the right to verify the accuracy of the information in the PSAP databases.
- 2.4.4 BellSouth shall bill and Interprise America shall pay the rates set forth in Part IV of this Agreement for INP. Billing and payment shall be in accordance with the applicable terms and conditions set forth in this Rates Agreement.

3. **Permanent Number Portability (PNP)**

PNP is currently being worked in industry forums. The results of these forums will dictate the industry direction of PNP. BellSouth agrees to

implement PNP as directed by the FCC in FCC Docket 95-116 and the appropriate industry forums.

4. **Requirements for INP and PNP**

4.1 **White and Yellow Page Listings**

Pursuant in Section 19 of the General Terms and Conditions of the Agreement, BellSouth shall provide and maintain for Interprise America one (1) white page and one (1) yellow page (if applicable) listing for each Interprise America subscriber that has ported its number from BellSouth, consistent with that specified for Provisioning in this Agreement. The listing and handling of listed and nonlisted telephone numbers will be at least at parity with that provided by BellSouth to its own subscribers.

4.2 **DELETED**

4.3 **Testing**

BellSouth and Interprise America shall cooperate in conducting Interprise America's testing to ensure interconnectivity between systems. BellSouth shall inform Interprise America of any system updates that may affect the Interprise America network and BellSouth shall, at Interprise America's request, perform tests to validate the operation of the network. Additional testing requirements may apply as specified by this Agreement.

4.4 **Non-Geographical Numbers**

BellSouth shall not be required to provide number portability for non-geographic services (e.g., 500 and 900 NPAs, and 976 NXX number services) under this Agreement.

4.5 **Engineering and Maintenance**

BellSouth and Interprise America will cooperate to ensure that performance of trunking and signaling capacity is engineered and managed at levels which are at least at parity with that provided by BellSouth to its subscribers and to ensure effective maintenance testing through activities such as routine testing practices, network trouble isolation processes and review of operational elements for translations, routing and network fault isolation. Additional specific engineering and maintenance requirements shall apply as specified in this Agreement.

4.6 BellSouth shall provide Interprise America with accurate billing and Customer Account Record Exchange data for Interprise America subscribers whose numbers have been ported.

4.7 **Operator Services and Directory Assistance**

With respect to operator services and directory assistance associated with LNP for Interprise America subscribers, BellSouth shall provide the following:

- 4.7.1 While INP is deployed and prior to conversion to PNP:
 - 4.7.1.1 If requested by Interprise America, BellSouth shall provide Emergency Interrupt (EI) Trunks to the Interprise America End Office for BLV/BLI call requests for lines that terminate at the Interprise America End Office.
 - 4.7.1.2 When a BLV/BLI request for a ported number is directed to a BellSouth operator and the query is not successful (i.e., the request yields an abnormal result), the operator shall confirm whether the number has been ported and shall direct the request to the appropriate operator.
 - 4.7.1.3 When a customer chooses Interprise America as its local services provider and as a result such customer's number is ported to Interprise America, BellSouth shall remove from its Line Information Data Base (LIDB) all existing BellSouth issued Telephone Line Number (TLN)-based card numbers when a customer ports their number to Interprise America.
 - 4.7.1.4 BellSouth shall allow Interprise America to order provisioning of TLN calling cards and Billed Number Screening (BNS), in its LIDB, for ported numbers, as specified by Interprise America. BellSouth shall continue to allow Interprise America access to its LIDB. Other LIDB provisions are specified in this Agreement.
 - 4.7.1.5 Where BellSouth has control of directory listings for NXX codes containing ported numbers, BellSouth shall maintain entries for ported numbers as specified by Interprise America.

TABLE OF CONTENTS

	<u>PAGE</u>
NETWORK SECURITY	1
1. Protection of Service and Property	1
2. Revenue Protection	2
3. Law Enforcement Interface	3

NETWORK SECURITY

1. Protection of Service and Property

BellSouth shall exercise the same level of care it provides itself to prevent harm or damage to Interprise America, its employees, agents or customers, or their property. BellSouth agrees to take reasonable and prudent steps to ensure the adequate protection of Interprise America property located within BellSouth Premises including, but not limited to:

- 1.1 Restricting access to Interprise America equipment, support equipment, systems, tools and data, or spaces which, contain or house Interprise America equipment enclosures, to Interprise America employees and other authorized non-Interprise America personnel to the extent necessary to perform their specific job function.
- 1.2 Assuring that the physical security and the means of ingress and admission to spaces that house Interprise America equipment or equipment enclosures are equal to or exceed those provided for BellSouth pursuant to BellSouth Admissions Practices.
- 1.3 **DELETED**
- 1.4 **DELETED**
- 1.5 **DELETED**
- 1.6 **DELETED**
- 1.7 Limiting the keys used in its keying systems for spaces which contain or house Interprise America equipment or equipment enclosures to its employees and representatives for emergency access only. Interprise America shall further have the right to change locks on all spaces where deemed necessary for the protection and security of such spaces. In such an event, Interprise America shall provide BellSouth with replacement keys.
- 1.8 Insuring that doors that provide access to Interprise America equipment enclosures are equipped to protect against removal of hinge pins.
- 1.9 **DELETED**
- 1.10 **DELETED**
- 1.11 **DELETED**
- 1.12 Installing controls and logical security:

- to disconnect a user for a pre-determined period of inactivity on authorized ports;
- to protect customer proprietary information; and
- to databases to ensure both ongoing operational and update integrity.
- to assure that all approved system and modem access be secured through security servers and that access to or connection with a network element shall be established through a secure network or security gateway.
- to provide security in accordance with BellSouth BSP008-140-230BT (Design, Development, Maintenance and Administration Security Standards for Network Elements, Network Element Support Systems, and other Computer Systems.)

1.13 **DELETED**

2. **Revenue Protection**

2.1 Where BellSouth services are being resold and where Interprise America is using a BellSouth port, Interprise America will have the use of all present and future fraud prevention or revenue protection features, including prevention, detection, or control functionality embedded within any of the network elements available to BellSouth. These features include, but are not limited to, screening codes, call blocking of international, 800, 900, and 976 numbers. Interprise America and BellSouth will work cooperatively to prevent and research any fraud situation.

2.2 The party causing a provisioning, maintenance or signal network routing error that results in uncollectible or unbillable revenues to the other party shall be liable for the amount of the revenues lost by the party unable to bill or collect the revenues less costs that would have been incurred from gaining such revenues. The process for determining the amount of the liability will be as set forth in Attachment 7, Section 6 of this Agreement.

Uncollectible or unbillable revenues resulting from the accidental or malicious alteration of software underlying Network Elements or their subtending operational support systems by unauthorized third Parties shall be the responsibility of the Party having administrative control of access to said Network Element or operational support system software to the extent such unbillable or uncollectible revenue results from the gross negligence or willful act or omission of the Party having such administrative control.

2.3 BellSouth shall be responsible for any uncollectible or unbillable revenues resulting from the unauthorized physical attachment to loop facilities from

the Main Distribution Frame up to and including the Network Interface Device, including clip-on fraud to the extent such unbillable or uncollectible revenue results from the gross negligence or willful act or omission of BellSouth. BellSouth shall provide soft dial tone to allow only the completion of calls to final termination points required by law.

3. **Law Enforcement Interface**

BellSouth shall provide seven day a week/ twenty-four hour a day installation and information retrieval pertaining to traps, assistance involving emergency traces and information retrieval on customer invoked CLASS services, including call traces requested by Interprise America Security/Network services. BellSouth shall provide all necessary assistance to facilitate the execution of wiretap or dialed number recorder orders from law enforcement authorities.

ACRONYM	DEFINITION
AAA	American Arbitration Association
ABSBH	Average Busy Season Busy Hour
ACD	Automatic Call Distributor
AIN	Advanced Intelligent Network
ALEC	Alternative Local Exchange Carrier
ALI/DMS	Automatic Location Identification/Data Management Systems
AMA	Automated Message Accounting
ANSI	American National Standards Institute
ARPM	Average Revenue Per Message
ARS	Automatic Route Selection
ARU	Automatic Response Unit
ATIS	Alliance for Telecom Industry Solutions
ATM	Asynchronous Transfer Mode
B	Bearer
BACR	Billing Account Cross Reference
BAN	Billing Account Number
BAR	Billing Account Reference
BICI	Broadband Inter-Carrier Interface
BITS	Building Integrated Timing Supply
BLV	Busy Line Verification
BLV/ELI	Busy Line Verification/Emergency Line Interrupt
BNS	Billed Number Screening
BOC	Bell Operating Company
BOS	Billing Output Specifications
BRI	Basic Rate ISDN
BRCS	Business and Residential Customer Service
C	Network Element Combination
C-DTTA	Combo of Dedicated Transport & Tandem
C-LPLS	Combo of Loop & Local Switching
CABS	Carrier Access Billing Systems
CAMA ANI	Centralized Automatic Message Accounting - Automatic Number Identification
CAP	Competitive Access Provider
CCITT	Consultative Committee on International Telegraph & Telephone
CCL	Common Carrier Line
CCS	Communications Channel Signaling
CCS7	Common Channel Signaling System 7
CCSNIS	Common Channel Signaling Network Interface Specification
CI	Customer Interface
CIC	Carrier Identification Code

CF/B	Call Forward on Busy
CF-B/DA	Call Forward on Busy/Don't Answer
CF/DA	Call Forward Don't Answer
CgPN	Calling Party Number
CLASS	Custom Local Area Signaling Service
CLASS/LASS	Customer Local Area Signaling Services
CLC	Carrier Liaison Committee
CLEC	Competitive Local Exchange Carrier
CLLI	Common Language Location Identifier
CMDS	Centralized Message Distribution System
CMIP	Coded Mark Inversion Protocol
CN	Charge Number
CO	Central Office
CPE	Customer Premises Equipment
CRDD	Customer Requested Due Dates
CSD	Circuit Switched Data
CT	Common Transport
CY	Current Year
D	Data
DA	Directory Assistance
DACS	Digital Access Crossconnect Systems
DB	Database
DB	Service Central Points/Databases
DCC	Data Communications Channel
DCMS	Digital Circuit Multiplication Systems
DCS	Digital Cross-Connect System
DDD	Desired Due Date
DID	Direct Inward Dialing
DLC	Digital Loop Carrier
DLCI	Data Link Connection Identifier
DMOQs	Direct Measures of Quality
DN	Directory Numbers
DN-RI	Directory Number - Route Index
DS-1	Digital Signal Level One
DS-3	Digital Signal Level Three
DSAP	Due Date Support Application
DS0	Digital Signal Level Zero
DSI	Digital Speech Interpolation
DSN	Data Set Name
DSX	Digital Cross Connect
DT	Dedicated Transport
DTMF	Dual-Tone Multi Frequency
DTN	Destination Telephone Number
E	Network Element

E&M	Ear & Mouth Signaling
E-LP	Element Loop
EAMF	Equal Access Multi-Frequency
EBCDIC	Extended Binary-Coded Decimal Interexchange Code
EBI	Electronic Bonding Interface
EDD	Envelope Delay Distortion
EDI	Electronic Data Interchange
EFT	Electronic Fund Transfer
EI	Electronic Interface
EI	Emergency Interrupt
ELI	Emergency Line Interrupt
ERL	Echo Return Loss
EMR	Exchange Message Record
EO	End Office
ERMA	Engineering Records Mark-up and Assignment
ES	Errored Second
ESF	Extended Super Frame
ESL	Essential Service Line
ETTR	Estimated Time to Repair
FCC	Federal Communications Commission
FDI	Feeder Distribution Interface
FN	Fiber Node
FOC	Firm Order Confirmation
FRF	Frame Relay Forum
FUNI	Framebased User to Network Interface
GTT	Global Title Translation
HDBH	High-day Busy Hour
HDT	Host Digital Terminal
HFC	Hybrid Fiber Coax
HFC-HDT	Hybrid Fiber Coax - Host Digital Terminal
IBC	Initial Billing Company
IC/M	Intelligent Loop Concentrator/Multiplexer
ICS	Inter-Company Settlements
ID	Remote Identifiers
IEC	Interexchange Carrier
IECs	Interexchange Carriers
IEEE	Institute of Electrical and Electronic Engineers
IISP	Interim Interswitch Signaling Protocol
ILEC	Incumbent Local Exchange Carrier
IMD	Intermodulation Distortion
INA	Integrated Network Access
INP	Interim Number Portability
IPP	Independent Payphone Provider
ISDN	Integrated Services Digital Network

ISDNUP	Integrated Services Digital Network User Part
ISNI	Intermediate Signal Network Identifier
ISO	International Standardization Organization
ISUP	Integrated Services User Part
ITU	International Telecommunications Union
IVMS	Interswitch Voice Messaging Service
IXC	Interexchange Carriers
LARG	LIDB Access Routing Guide
LASS	Local Area Signaling Services
LATA	Local Access Transport Area
LC	Loop Concentrator/Multiplexor
LCC	Line Class Code
LCSC	Local Carrier Service Center
LD	Loop Distribution
LEC	Local Exchange Carrier
LEC DA	LEC Directory Assistance
LEC SCE	LEC Service Creation Environment
LEC SCP	LEC Service Control Point
LEC SMS	LEC Service Management System
LEC SSP	LEC Service Switching Point
LERG	Local Exchange Routing Guide
LF	Loop Feeder
LGX	Lightguide Cross-Connect
LIDB	Line Information Data Base
LMI	Local Management Interface
LNP	Local Number Portability
LOF	Loss of Frame
LOS	Loss of Signal
LP	Loop
LRCL	Logical Record Length
LRN	Local Routing Number
LS	Local Switching
LSO	Local Serving Office
LSSGR	LATA Switching Systems Generic Requirements
MDF	Main Distribution Frame
MDU	Multiple Dwelling Unit
MDU/BCL	Multiple Dwelling Unit/Business Customer Location
MF	Multi-Frequency
MIB	Management Information Base
MLT	Mechanized Loop Tests
MOP	Methods of Procedure
MOS	Modified Operator Services
MPB	Meet-Point Billing
MR	Modification Request

MRVT	MTP Routing Verification Test
MSAG	Master Street & Address Guide
MTP	Message Transfer Port
MTTR	Mean Time to Repair
MWI	Message Waiting Indicator
NCS	National Communications System
NEBS	Network Equipment Building System
NEC	National Electrical Code
NECA	National Exchange Carrier Association
NESC	National Electrical Safety Code
NGDLC	Next Generation Digital Loop Carrier
NI	Network Interface Device
NID	Network Interface Device
NIU	Network Interface Unit
NMS	Network Management System
NNI	Network to Network Interface
NSEP	National Security Emergency Preparedness
NVT	Network Validation Test
OAM	Operation and Maintenance
OAM&P	Operations Administration Maintenance & Provisioning
OBF	Open & Billing Forum
OC	Optical Carrier
OSHA	Occupational Safety and Health Act
ODS	Optical Distribution
OLI	Originating Line Indicator
OMAP	Operations, Maintenance & Administration Part
OOF	Out-of-Frame
ORT	Operational Readiness Test
OS	Operator Services
OSPS	Operator Services Position System
OSS	Operations Support Systems
OSSGR	Operator Services Systems Generic Requirements
OTS	Operator Transfer Service
PBX	Private Branch Exchange
PDD	Post Dial Delay
PDH	Plesiochronous Digital Hierarchy
PEC	Primary Exchange Carrier
PIC	Primary Interexchange Carrier
PLU	Percent Local Usage
PNP	Permanent Number Portability
POI	Point of Interface
POI	Points of Interconnection
POT	Point of Termination
POTS	Plain Old Telephone Service

PRI	Primary Rate Interface
PSAP	Public Safety Answering Point
PSD	Packet Switched Data
P/SIMS	Products and Services Inventory Management System
PSTN	Public Switched Telecommunications Network
PUC	Public Utilities Commission
RAO	Revenue Accounting Office
RCF	Remote Call Forwarding
RECFM	Record Format
RI	Route Index
RIC	Residual Interconnection Charges
RI-PH	Route Index - Portability Hub
ROW	Right of Way
RPC	Regional Processing Center
RSAG	Regional Street Address Guide
RSM	Remote Switch Module
RT	Remote Terminal
SAG	Street Address Guide
SBC	Subsequent Billing Company
SCCP	Signaling Connection Control Point
SCD	Signal Correlated Distortion
SCE	Service Creation Environment
SCP	Service Control Points
SDH	Synchronous Digital Hierarchy
SECAB	Small Exchange Carrier Access Billing
SES	Severely Errored Second
SFE	Short Failure Event
SL	Signaling Link Transport
SMDI	Standard Message Desk Interface
SMDI-E	Standard Message Desk Interface - Enhanced
SMS	Service Management System
S/N	Signal-to-Noise Ratio
SNMP	Simple Network Management Protocol
SONET	Synchronous Optical Network
SPOC	Single Point of Contact
SPOI	Signaling Point of Interconnection
SRVT	SCCP Routing Verification Test
SS	SS7 Message Transfer & Connection Control
SS7	Signaling System 7
SSP	Switching Services Port
STP	Signaling Transfer Point
STPS	Signaling Transfer Point Switch
STS	Synchronous Transport Signal
SWF-DSI	Switched Functional DS1 Service Capability

T&M	Time & Material
TCAP	Transaction Capabilities Application Port
TDEV	Time Deviation
TDI	Tie Down Information
TELRIC	Total Element Long Run Incremental Cost
THDBH	Ten-High-Day Busy Hour
TIA/EIA	Telecommunications Industries Association/Electronic Industries Association
TLN	Telephone Line Number
TR	Technical Requirements
TS	Tandem Switching
TSG	Trunk Sub-Group
TSGR	Transport System Generic Requirements
TSLRIC	Total Service Long Run Incremental Cost
TSP	Telecommunications Services Priority
UI	Unit Intervals
UNI	User to Network Interface
VB	Variable Block
VCI	Virtual Channel Identifier
VF	Voice Frequency
WDM	Wavelength Division Multiplex
WTN	Working Telephone Number

"Act" means the Telecommunications Act of 1996.

"Advanced Intelligent Network (AIN)" is a network functionality that permits specific conditions to be programmed into a switch which, when met, directs the switch to suspend call processing and to receive special instructions for further call handling instructions in order to enable carriers to offer advanced features and services.

"Affiliate" is as defined in the Act.

"Agreement" has the meaning set forth in Section 1 of the General Terms and Conditions.

"AMA" means the Automated Message Accounting structure inherent in switch technology that initially records telecommunication message information. AMA format is contained in the Automated Message Accounting document, published by Bellcore as GR-1100-CORE which defines the industry standard for message recording.

"Ancillary Functions" has the meaning set forth in Part 3 of the General Terms and Conditions.

"Applicable Law" is as defined in Section 22.6 of the General Terms and Conditions.

"As Defined in the Act" means as specifically defined by the Act and as interpreted in the duly authorized rules and regulations of the FCC or Commission.

"Automatic Location Identification/Data Management System (ALI/DMS)" means the emergency services (E911/911) database containing customer location information (including name, address, telephone number, and sometimes special information from the local service provider) used to determine to which Public Safety Answering Point ("PSAP") to route the call.

"Automatic Route Selection (ARS)" is a service feature that provides for automatic selection of the least expensive or most appropriate transmission facility for each call based on criteria programmed into the system.

"Bellcore" means Bell Communications Research, Inc.

"BellSouth" has the meaning set forth in the preface.

"BellSouth Customers" means any business or residence customer for BellSouth services.

"Bill and Keep" is a reciprocal compensation arrangement whereby the compensation that one company offers to another for the completion of its calls is the agreement to complete the other company's calls in a like manner.

"BLV/BLI (Busy Line Verify/Busy Line Interrupt) Traffic" or "BLV/BLI Call" means an operator call in which the end user inquires as to the busy status of, or requests an interruption of, a call on an Exchange Service.

"Bona Fide Request" has the meaning ascribed to such term in Attachment 14.

"CABS" means the Carrier Access Billing System which is contained in a document prepared under the direction of the Billing Committee of the OBF. The Carrier Access Billing System document is published by Bellcore in Volumes 1, 1A, 2, 3, 3A, 4 and 5 as Special Reports SR-OPT-001868, SR-OPT-001869, SR-OPT-001871, SR-OPT-001872, SR-OPT-001873, SR-OPT-001874, and SR-OPT-001875, respectively, and contains the recommended guidelines for the billing of access and other connectivity services.

"CENTREX" means a Telecommunications Service that uses central office switching equipment for call routing to handle direct dialing of calls, and to provide many private branch exchange-like features and includes BellSouth's ESSX®, MultiServe®, Prestige® services.

"CLASS (Custom Local Area Signaling Service) and Custom Features" means a grouping of optional enhancements to basic local exchange service that offers special call handling features to residential and single-line business customers (e.g., call waiting, call forwarding and automatic redial).

"Claim" has the meaning ascribed to such term in Section 10.4 of the General Terms and Conditions.

"Collocation" has the meaning set forth in Attachment 3, Section 2.1.

"Commission" means State Commission as Defined in the Act.

"Common Transport" has the meaning set forth in Attachment 2, Section 9.1.

"Conduit" has the meaning set forth in Attachment 3, Section 3.

"Confidential Information" means confidential or proprietary technical or business information given by the Discloser to the Recipient and further defined in Section 17.1 of the General Terms and Conditions.

"Contract Year" means a twelve (12) month period during the term of the contract commencing on the Effective Date and each anniversary thereof.

“Cooperative Testing” has the meaning set forth in Attachment 2, Section 16.1.1.

“CRIS/CLUB” means Customer Record Information System/Customer Local Usage Billing.

“Customer Proprietary Network Information (CPNI)” is as defined in the Act.

“Customer Usage Data” means the local Telecommunications Services usage data of a Interprise America Customer, measured in minutes, sub-minute increments, message units, or otherwise, that is recorded by BellSouth and forwarded to Interprise America.

“Dark Fiber” has the meaning set forth in Attachment 2, Section 15.1.1.

“Databases” has the meaning set forth in Attachment 2, Section 13.1.1

“Dedicated Transport” has the meaning set forth in Attachment 2, Section 10.1.1.1.

“Defaulting Party” is a Party in breach of a material term or condition of the Agreement.

“Digital Cross-Connect System” has the meaning set forth in Attachment 2, Sections 10.5.1.1 and 10.5.1.2.

“Directory Listings” has the meaning set forth in Section 19.1 of the General Terms and Conditions.

“Directory Assistance Service” has the meaning set forth in Attachment 2, Section 8.3.1.

“Discloser” means that Party to this Agreement which has disclosed Confidential Information to the other Party.

“Distribution Media” has the meaning set forth in Attachment 2 Section 4.2.1.1.

“Effective Date” is the date indicated in the Preface on which the Agreement shall become effective.

“EMR” means the Exchange Message Record System used among LECs for exchanging telecommunications message information for billable, non-billable, sample, settlement and study data. EMR format is contained in BR-010-200-010 CRIS Exchange Message Record, published by Bellcore and which defines the industry standard for exchange message records.

"Environmental Hazard" means (1) a release, discharge, leak, spill or disposal (collectively referred to hereafter as "release") of HAZARDOUS MATERIALS has occurred on premises or property that is related to the performance of this Agreement and that such affected material or media is demonstrated through applicable or appropriate testing method to require remediation or removal as determined by all laws, ordinances, statutes, codes, rules, regulations, orders and decrees of the United States, the state, county, city or any other political subdivision in which the release has occurred, and any other political subdivision, agency or instrumentality exercising jurisdiction over the release, including any applicable federal and state case law and common law interpreting any of the foregoing or 2) any event involving, or exposure to, HAZARDOUS MATERIALS which poses risks to human health, safety or the environment (including, without limitation, indoor or outdoor environment(s) and is regulated under any applicable laws or regulations as described in (1).

"Enhanced White Pages" means optional features available for White Pages Directory listings (e.g., bold, all capitals, additional line of text, indented).

"Enhanced Yellow Pages" means optional features available for Yellow Pages Directory listings (e.g., red type, bold, all capitals, additional line of text, indented).

"E911 Service" is a method of routing 911 calls to a PSAP that uses customer location data in the ALI/DMS to determine the PSAP to which a call should be routed.

"Filing" has the meaning set forth in Section 9.2 of the General Terms and Conditions.

"Follow-on Agreement" has the meaning set forth in Section 2.2 of the General Terms and Conditions.

"Governmental Authority" means any federal, state, local, foreign or international court, government, department, Commission, board, bureau, agency, official, or other regulatory, administrative, legislative or judicial authority with jurisdiction.

"Hazardous Materials" means any hazardous or toxic substance, material or waste listed in the United States Department of Transportation HAZARDOUS MATERIALS Table at 49 CFR 172.101; any hazardous substance listed by the Environmental Protection Agency (EPA) under the Comprehensive Environmental, Response, Compensation, and Liability Act (CERCLA), 42 U.S.C. §§ 9601 et. seq., as amended, and found at 40 CFR Part 302; any hazardous waste listed under the Resource Conservation and Recovery Act (RCRA), 42 U.S.C. §§ 6901 et. seq., as amended, and found at 40 CFR Part 261; any toxic substance regulated by the Toxic Substances Control Act, 15 U.S.C. §§ 2601 et. seq., as amended; any insecticide, fungicide, or rodenticide regulated by the Federal Insecticide, Fungicide, and Rodenticide Act, 7 U.S.C. §§ 136 et. seq.; and the following specified

substances or materials, that may or may not be regulated by the above: (1) asbestos or asbestos-containing materials; (2) petroleum or petroleum-based or derived products or by-products; (3) polychlorinated biphenyls (PCBs); and (4) radon.

"Interconnection" is as described in the Act and refers to the linking of two or more telecommunications networks for the purpose of terminating local telephone calls.

"Interim Number Portability (INP)" is as described in the Act and means the delivery of LNP capabilities, from a customer standpoint in terms of call completion, with as little impairment of functioning, quality, reliability, and convenience as possible and from a carrier standpoint in terms of compensation, through the use of existing and available call routing, forwarding, and addressing capabilities.

"Line Information Data Base(s) (LIDB)" means one or all, as the context may require, of the Line Information Databases owned individually by ILECs and other entities which provide, among other things, calling card validation functionality for telephone line number cards issued by ILECs and other entities. A LIDB also contains validation data for collect and third number-billed calls, which include billed number screening.

"Local Exchange Carrier" is as defined in the Act.

"Local Number Portability (LNP)" means Interim Number Portability (INP) or Permanent Number Portability (PNP).

"Local Number Portability Database" supplies routing numbers for calls involving numbers that have been ported from one local service provider to another and is further defined in Attachment 2, Section 13.3.1.

"Local Service" has the meaning set forth in Section 1 of the General Terms and Conditions.

"Local Switching" has the meaning set forth in Attachment 2, Section 7.1.

"Local Traffic" means any telephone call that originates and terminates in the same LATA and is billed by the originating Party as a local call, including any call terminating in an exchange outside of BellSouth's service area with respect to which BellSouth has a local interconnection agreement with an independent LEC, with which Interprise America is not directly interconnected.

"Loop" or "Loop Combination" has the meaning set forth in Attachment 2, Section 2.1.1.

"Loop Concentrator/Multiplexer" has the meaning set forth in Attachment 2, Section 5.1.

“Loop Distribution” has the meaning set forth in Attachment 2, Section 4.

“Loop Feeder” has the meaning set forth in Attachment 2, Section 6.1.1.

"MECAB" means the Multiple Exchange Carrier Access Billing document prepared under the direction the Billing Committee of the OBF. The Multiple Exchange Carrier Access Billing document, published by Bellcore as Special Report SR-BDS-000983, contains the recommended guidelines for the billing of access and other connectivity services provided by two or more LECs (including LECs and CLECs), or by one LEC or CLEC in two or more states within a single LATA.

"MECOD" means the Multiple Exchange Carriers Ordering and Design (MECOD) Guidelines for Access Services- Industry Support Interface, a document developed under the auspices of the Billing Committee of the OBF. The MECOD document, published by Bellcore as Special Report SR STS-002643, establishes recommended guidelines for processing orders for access and other connectivity services which is to be provided by two or more LECs (including LECs and CLECs), or by one LEC or CLEC in two or more states within a single LATA.

"Network Element" is as defined in the Act.

"Network Interface Device" has the meaning set forth in Attachment 2, Section 4.1.1.1.

"911 Service" means a universal telephone number which gives the public direct access to the PSAP. Basic 911 service collects 911 calls from one or more local exchange switches that serve a geographic area. The calls are then sent to the correct authority designated to receive such calls.

"OBF" means the Ordering and Billing Forum (OBF), which functions under the auspices of the Carrier Liaison Committee (CLC) of the Alliance for Telecommunications Industry Solutions (ATIS).

“Operator Systems” has the meaning set forth in Attachment 2, Section 8.1.

“OUTPLOC” is as described in Section 28.7.22 of Part I of the Agreement.

"Parties" means Interprise America and BellSouth.

"Permanent Number Portability (PNP)" means the use of the Local Routing Number (LRN) database solution to provide fully transparent LNP for all customers and all providers without limitation.

"Pole Attachment" has the meaning set forth in Attachment 3.

"Premises" is as defined in the Act.

"Public Safety Answering Point (PSAP)" means the designated agency to which calls to E911/911 services are routed.

"Real Time" means the actual time in which an event takes place, with the reporting on or the recording of the event practically simultaneous with its occurrence.

"Recipient" means that Party to this Agreement to which Confidential Information has been disclosed by the other Party.

"Recorded Usage Data" has the meaning set forth in Attachment 7, Section 3.1.

"Release" means any release, spill, emission, leaking, pumping, injection, deposit, disposal, discharge, dispersal, leaching, or migration, including without limitation, the movement of Environmental Hazards through or in the air, soil, surface water or groundwater, or any action or omission that causes Environmental Hazards to spread or become more toxic or more expensive to investigate or remediate.

"Retail Rates" means the lowest prices that BellSouth actually charges its customers.

"Rights of Way (ROW)" has the meaning set forth in Attachment 3.

"RLEC" The terms Regional Local Exchange Company ("RLEC"), Local Exchange Company ("LEC"), and Incumbent Local Exchange ("ILEC") are used interchangeably throughout this Agreement.

"SECAB" means the Small Exchange Carrier Access Billing document prepared by the Billing Committee of the OBF. The Small Exchange Carrier Access Billing document, published by Bellcore as Special Report SR OPT - 001856, contains the recommended guidelines for the billing of access and other connectivity services.

"Served Premises" means collectively, the Interprise America designated locations to which Interprise America orders Network Elements, Ancillary Functions or Combinations.

"Service Control Point" has the meaning set forth in Attachment 2, Section 13.1.2.

"Services and Elements" means collectively Local Services, Network Elements, Combinations, Ancillary Functions, and Additional Features.

"Service Order" means the placement of an order for Services or Elements.

"Signaling Link Transport" has the meaning set forth in Attachment 2, Section 11.1.

"Signaling Transfer Points" has the meaning set forth in Attachment 2, Section 12.1.

"Interprise America" has the meaning set forth in the Preface.

"Interprise America Customer" means any business or residential customer for Interprise America services.

"SS7 Network Interconnection" has the meaning set forth in Attachment 2.

"Synchronization" has the meaning set forth in Attachment 2, Section 16.4.1.

"Tandem Switching" has the meaning set forth in Attachment 2, 14.1.

"Telephone Relay Service" provides to speech and hearing-impaired callers a service that enables callers to type a message into a telephone set equipped with a keypad and message screen and to have a line operator read the message to a recipient and to relay message recipients' response to the speech or hearing-impaired caller.

"Voluntary Federal Customer Financial Assistance Programs" are Telecommunications Services provided to low-income subscribers, pursuant to requirements established by the appropriate state regulatory body.

"Waste" means all hazardous and non-hazardous substances and materials which are intended to be discarded, scrapped, or recycled, associated with activities Interprise America or BellSouth or their respective contractors or agents perform at Work Locations. It shall be presumed that all substances or materials associated with such activities, that are not in use or incorporated into structures (including without limitation damaged components or tools, leftovers, containers, garbage, scrap, residues or byproducts), except for substances and materials that Interprise America, BellSouth or their respective contractors or agents intend to use in their original form in connection with similar activities, are Waste. "Waste" shall not include substances, materials or components incorporated into structures (such as cable routes) even after such components or structure are no longer in current use.

"Work Locations" means any real estate that BellSouth owns, leases or licenses or in which it holds easements or other rights to use, or does use, in connection with this Agreement.

PERFORMANCE MEASUREMENT

RESERVED FOR FUTURE USE

BONA FIDE REQUEST PROCESS

- 1.0 Bona Fide Requests are to be used when Interprise America requests a change to any Services and Elements provided hereunder, including features, capabilities, or functionality.
- 1.1 A Bona Fide Request shall be submitted in writing by Interprise America and shall specifically identify the required service date, technical requirements, space requirements and/or such specifications that clearly define the request such that BellSouth has sufficient information to analyze and prepare a response. Such a request also shall include Interprise America's designation of the request as being (i) pursuant to the Telecommunications Act of 1996 or (ii) pursuant to the needs of the business.
- 1.2 Although not expected to do so, Interprise America may cancel, without penalty, a Bona Fide Request in writing at any time. BellSouth will then cease analysis of the request.
- 1.3 Within two (2) business days of its receipt, BellSouth shall acknowledge in writing, the receipt of the Bona Fide Request and identify a single point of contact and any additional information needed to process the request.
- 1.4 Except under extraordinary circumstances, within thirty (30) days of its receipt of a Bona Fide Request, BellSouth shall provide to Interprise America a preliminary analysis of the Bona Fide Request. The preliminary analysis will include BellSouth's proposed price (plus or minus 25 percent) and state whether BellSouth can meet Interprise America's requirements, the requested availability date, or, if BellSouth cannot meet such date, provide an alternative proposed date together with a detailed explanation as to why BellSouth is not able to meet Interprise America's requested availability date. BellSouth also shall indicate in this analysis its agreement or disagreement with Interprise America's designation of the request as being pursuant to the Act or pursuant to the needs of the business. If BellSouth does not agree with Interprise America's designation, it may utilize the procedures set forth in Section 15 of the General Terms and Conditions of this Agreement. In no event, however, shall any such dispute delay BellSouth's processing of the request. If BellSouth determines that it is not able to provide Interprise America with a preliminary analysis within thirty (30) days of BellSouth's receipt of a Bona Fide Need request, BellSouth will inform Interprise America as soon as practicable. Interprise America and BellSouth will then determine a mutually agreeable date for receipt of the preliminary analysis.
- 1.5 As soon as possible, but in no event more than ninety (90) days after receipt of the request, BellSouth shall provide Interprise America with a firm Bona Fide Request quote which will include, at a minimum, the firm availability

- date, the applicable rates and the installation intervals, and a binding price quote.
- 1.6 Unless Interprise America agrees otherwise, all proposed prices shall be the pricing principles of this Agreement, in accordance with the Act, and any applicable FCC and Commission rules and regulations. Payments for services purchased under a Bona Fide Request will be made as specified in this Agreement, unless otherwise agreed to by Interprise America.
 - 1.7 Within thirty (30) days after receiving the firm Bona Fide Request quote from BellSouth, Interprise America will notify BellSouth in writing of its acceptance or rejection of BellSouth's proposal. If at any time an agreement cannot be reached as to the terms and conditions or price of the request, or if BellSouth responds that it cannot or will not offer the requested item in the Bona Fide Request and Interprise America deems the item essential to its business operations, and deems BellSouth's position to be inconsistent with the Act, FCC or Commission regulations and/or the requirements of this Agreement, the dispute may be resolved pursuant to Section 15 of the General Terms and Conditions of this Agreement.

**INTERFACE REQUIREMENTS FOR ORDERING AND PROVISIONING,
MAINTENANCE AND REPAIR AND PRE-ORDERING**

1. Purpose

1.1 This Attachment 15 sets forth the interface requirements for ordering and provisioning, maintenance and repair and pre-ordering, where Interprise America provides service to its customers through resale of Local Services or through the use of unbundled Network Elements.

1.2 For all Local Services, Network Elements ordered under this Agreement, BellSouth will provide Interprise America and its customers ordering and provisioning, maintenance, and repair and pre-ordering services within the same level and quality of service available to BellSouth, its Affiliates, and its customers.

1.3 **DELETED**

2. Use of Standards

2.1 As described below, Interprise America and BellSouth agree to implement each interface based upon existing and evolving industry standards. The Parties shall transition the electronic interfaces to industry standards as those standards become available.

2.2 **DELETED**

3. Reimbursement

3.1 Reimbursement for operational interfaces shall be as determined by the appropriate regulatory agency as set forth in Part IV.

4. Interim Interfaces

4.1 The Parties have agreed upon certain interim interfaces to support Local Services and Network Elements including:

- Ordering and Provisioning
- Maintenance and Repair
- Pre-Ordering
 - Address Validation
 - Service Feature Availability
 - Telephone Number Assignment
 - Appointment Scheduling
 - Customer Service Record Requests

Interprise America - KY

9/15/97

4.2 The interim interfaces for Ordering and Provisioning for Local Services a Phase 1 Electronic Data Interchange (EDI) Interface based on mutually agreed upon specifications. BellSouth agrees to share information regarding Phase 2 EDI interfaces, solicit Interprise America's comments, and as appropriate incorporate such comments into subsequent joint testing and implementation of the interface. BellSouth is engaged in the integration of this EDI feed into a Mechanized Service Order Generation System. Errors, rejects, jeopardy notices, and in-process provisioning status reports are provided through a combination of telephone calls and facsimile exchanges.

4.3 For Loop and Transport Unbundled Network Elements, the interim interfaces utilize BellSouth's Access Service Request (ASR) process with manual intervention as required, including the ordering of:

- CCS-SS7 Signaling Connections/Access Links
- Line Information DataBase (LIDB) - Validation Service
- 800 Access Ten Digit Screening
- Local Interconnection/Trunking Arrangements
- Operator Services - Directory Assistance and Toll & Assistance
- Unbundled Exchange Access Loop

4.4 The interim interfaces for Maintenance and Repair include:

- a) telephonic exchanges between Interprise America and BellSouth maintenance and repair work center personnel; and
- b) the use of BellSouth's TAFI interface for Plain Old Telephone Service (POTS) when available.

These will be used to accomplish the functions desired to be obtainable over the interface described in Section 5 following.

4.5 The interim interfaces for Pre-Ordering are as follows:

Address Validation - on-line Local Area Network to Local Area Network connectivity to BellSouth's Regional Street Address Guide.

Service/Feature Availability - file transfer download of BellSouth's Products/Services Inventory Management System files via the Network Data Mover Network using CONNECT:direct.

Telephone Number Assignment - request for and file transfer download of blocks of numbers reserved for Interprise America's use via the Network Data Mover Network using CONNECT: direct.

Interprise America - KY

9/15/97

Appointment Scheduling - paper standard interval guidelines.

Customer Service Record Requests - BellSouth agrees to provide Customer Service Records upon request from Interprise America. These records will be provided to Interprise America via facsimile or other mutually agreed upon methods that have been reviewed by the CUC and approved by the Commission.

- 4.5.1 Interprise America acknowledges that BellSouth is developing additional interim interfaces that provide the capability to perform Pre-Ordering via an electronic interface using web technology. Interprise America reserves the right to review specifications for such interfaces as they become available, and the right to elect to use any such interface it deems operationally and economically viable.

Dates

- 4.6 BellSouth and Interprise America agree to work together to develop and implement an electronic communication interface that will replace these interim interfaces with the electronic interfaces described below. For purposes of this Attachment electronic communication interface defines a machine-to-machine or application-to-application interface and excludes an interface that provides a presentation for manual entry.
- 4.7 The Parties further agree to work collaboratively within the industry to establish and conform to uniform industry standards for electronic interfaces for ordering and provisioning, maintenance and repair and pre-ordering. Neither Party waives any of its rights as participants in industry forums in the implementation of the standards.

5. Electronic Interfaces for Ordering and Provisioning

5.1 Local Service Resale

- 5.1.1 The exchange of information relating to the ordering and provisioning of Local Service, when Interprise America is the customer of record for the resold service(s), will be based upon the most current interpretations of the American National Standards Institute (ANSI) Accredited Standards Committee (ASC) X12 Standards as documented by the Service Order Subcommittee (SOSC) of the Telecommunications Industry Forum/Electronic Data Interchange (TCIF/EDI) committee.

Interprise America - KY

9/15/97

- 5.1.2 The information exchange will be forms-based, using Local Service Request (LSR) Form, End User Information Form, and the Resale Service Form developed by the OBF. The SOSC interpretations of the 850, 860, 855, 864, 865, and 997 transactions, in accordance with the OBF forms, will be used to convey, when available and where applicable, all the necessary data to connect, modify or disconnect Local Services of BellSouth that Interprise America resells, including the capability to establish directory listings and perform service suspension, denial and restoral. In the absence of SOSC interpretations of the 850, 860, 855, 864, 854, and 997 transactions, both Parties agree to use the mutually defined EDI mappings.
- 5.1.3 If the EDI translator of BellSouth detects a syntax error(s), BellSouth will reject the order using the 997 transaction, identifying the type of syntax error(s) and indicate to Interprise America that the entire order must be resubmitted. If BellSouth detects that agreed upon data is missing or incorrect, subsequent to the EDI translator processing, BellSouth will reject the Interprise America order and indicate the need for Interprise America to resubmit the order. BellSouth agrees to develop an acceptable X.12 EDI transaction type for identifying and advising Interprise America of missing or incorrect data.
- 5.1.4 Interprise America and BellSouth will use an X.400 message standard, until it is replaced with a transaction-based protocol, and a mutually agreeable X.25 or TCP/IP based transport network for exchange of transactions. Interprise America and BellSouth will translate ordering and provisioning requests originating in their internal processes into the agreed upon forms and EDI transactions.
- 5.15 Both Parties agree to complete the defined translations, establish a query-response cycle time commitment, including but not limited to order rejection and firm order confirmation, and proceed to systems readiness testing, as more fully described in Section 7, that will result in a fully operational interface for resale of Local Service by pursuant to Section 4.6.2 of this Attachment.
- 5.1.6 Interprise America and BellSouth agree to adapt the interface based on evolving standards. To the extent changes to SOSC implementation guidelines affect local service ordering, the Parties agree to use best efforts to implement such changes, including testing of changes introduced, within 7 months of the publication date of the TCIF/SOSC guidelines. This preceding target implementation obligation may be modified by mutual agreement.
- 5.2 Unbundled Network Elements

Interprise America - KY

9/15/97

- 5.2.1 Interprise America and BellSouth will use two types of orders, an infrastructure Provisioning order and a Customer Specific Provisioning order, to establish local service capabilities based upon Unbundled Network Element architecture. The Infrastructure Provisioning order notifies BellSouth of the common use Network Elements that Interprise America will require. For services covered in BellSouth's "OLEC-to-BellSouth Facility-Based" guide, this notification will occur through use of an ASR. BellSouth will make periodic updates to the OLEC guide to reflect UNEs that are found to be technically feasible by the appropriate regulatory agency. For services not covered in BellSouth's "OLEC-to-BellSouth Facility-Based" guide, this notification will occur through use of an Infrastructure Footprint Form. The Infrastructure Footprint Form, when applicable, and the associated ASR forms (Local Switching, Interoffice Transport, Signaling and Database, Operator Services and DA) order the Network Elements used in common (across Interprise America retail customers) and identify the geographic area Interprise America expects to serve through the Network Elements ordered. Interprise America and BellSouth may mutually agree to use an alternative format for exchange of Footprint Order related information, provided that the same information content is delivered.
- 5.2.2 For services not covered in BellSouth's "OLEC-to-BellSouth Facility-Based" guide, BellSouth will accept the Infrastructure/Footprint Form developed by Interprise America, or the mutually agreed upon equivalent format, until such time Interprise America and BellSouth agree that the OBF has adopted an acceptable alternative form. In addition, BellSouth will accept a modified version of the OBF Translation Questionnaire (TQ) Form. The modified TQ will be sent to BellSouth when BellSouth must modify the routing tables for its end offices to accommodate the treatment of customer calling associated with the combination of Network Elements that Interprise America is employing to deliver service. Interprise America will provide the Infrastructure/Footprint Form and all associated ASR forms.
- 5.2.3 When applicable, BellSouth will accept delivery of the Infrastructure Footprint Form and the modified TQ through the ASR process, including passing of the information over a file transfer network (e.g., Network Data Mover Network) using the CONNECT:direct file transfer product unless another mutually agreeable exchange mechanism is established.
- 5.2.4 Interprise America and BellSouth agree to adapt the interface based upon evolving standards. Changes to OBF ASR forms and implementation guidelines, to the extent relevant to ordering and provisioning for Local Services, will be implemented based upon industry standard

implementation schedules as set by the Telecommunications Service ordering Committee of OBF. This preceding target implementation obligation may be modified by mutual agreement.

- 5.2.5 When applicable, the Customer Specific Provisioning order will be based upon OBF LSR forms. The applicable SOSC implementation guidelines described in the prior paragraphs relating to resale of BellSouth retail services also apply to the Customer Specific Provisioning orders.
- 5.2.5.1 Unbundled loops are an exception to Section 5.2.5 above. Currently, BellSouth accepts an ASR form for the ordering of unbundled loops. BellSouth will use best efforts to adopt the LSR as the ordering document within 7 months of the published release of the TCIF/SOSC standard for ordering unbundled loops via EDI.
- 5.2.6 When applicable, BellSouth agrees that the information exchange will be forms-based using the Local Service Request Form, End User Information Form, Loop Service Form (which may ultimately be renamed the Loop Element form) and Port Form (which may ultimately be renamed the Switch Element Form) developed by the OBF. The SOSC interpretation of 850, 860, 855, 864, 865, and 997 transactions, in accordance with the OBF forms, will be used to convey all the necessary data to connect, modify or disconnect BellSouth's customer-specific UNEs employed by Interprise America to deliver Local Services. Unless the Parties otherwise agree, all EDI-based transactions for ordering BellSouth's customer-specific UNEs will occur over the interface utilized by Interprise America ordering Local Service for resale. Errors and rejections of orders will be treated as described in the paragraphs relating to resale of BellSouth Local Services. Customer-specific elements include, but are not limited to, the customer loop, the network interface device, the customer-dedicated portion of the local switch and any combination thereof.
- 5.2.7 Interprise America and BellSouth will use an X.400 message standard, until it is replaced by a transaction-based protocol, and a mutually agreeable X.25 or TCP/IP based network to exchange requests. Interprise America and BellSouth will translate ordering and provisioning requests originating in their internal processes into the agreed upon forms and EDI transactions. Both Parties agree to complete the defined translations, establish a query-response cycle time commitment, including but not limited to order rejection and firm order confirmation, and proceed to systems readiness testing, as more fully described in Section 8, that will result in an operational interface for ordering UNEs by December 31, 1997. Interprise America and BellSouth agree to adapt the interface based upon evolving standards. To the extent changes to SOSC implementation guidelines affect local service ordering and provisioning for

Interprise America - KY

9/15/97

customer specific unbundled Network Elements, the Parties agree to use best efforts to implement such changes, including testing of changes introduced, within 7 months of the publication date of the TCIF/SOSC guidelines. This preceding target implementation obligation may be modified by mutual agreement.

5.3 Treatment of 860 Messages

5.3.1 BellSouth will accept an 860 transaction that contains the complete refresh of the previously provided order information (under the original 850 transaction) simultaneously with the supplemental (new/revised) information from Interprise America. This treatment with respect to the 860 transaction will be accepted by both Parties until the SOSC explicitly clarifies the information exchanges associated with supplementing orders or Interprise America and BellSouth mutually agreed to change the treatment. Interprise America and BellSouth will agree upon a mutually acceptable time frame for adapting their internal systems to accommodate any alteration to treatment of the 860 message described in this paragraph. In no event will the time frame for adaptation extend more than one year past the date the SOSC initiated change or Interprise America and BellSouth agreeing to modify the treatment of 860 messages.

6. **Electronic Interfaces for Maintenance and Repair**

6.1 Maintenance and repair information exchange will be transmitted over the same interface according to the same content definition both for resold BellSouth retail Local Services and for services Interprise America provides using Network Elements.

6.2 When technically feasible, Interprise America and BellSouth will, for the purpose of exchanging fault management information, establish an electronic bonding interface, based upon ANSI standards T1.227-1995 and T1.228-1995, and Electronic Communication Implementation Committee (ECIC) Trouble Report Format Definition (TRFD) Number 1 as defined in ECIC document ECIC/TRA/95-003, and all standards referenced within those documents. The Parties acknowledge that the present version of these standards supports different functions for different Network elements. Where a function is not presently supported for a given Network Element, the Parties agree to work collaboratively within the industry for its inclusion in future releases of the standards. The Parties will use and acknowledge functions currently implemented for reporting access circuit troubles. These functions include Enter Trouble, Request Trouble Report Status, Add Trouble Information, Modify Trouble Report Attributes, Trouble Report Attribute Value Change Notification and Cancel

Trouble Report, all of which are fully explained in clauses 6 and 9 of ANSI T1.228-1995.

6.3 Interprise America and BellSouth will exchange requests over a mutually agreeable X.25 based network or if mutually agreeable, a TCP/IP based network may be employed. Interprise America and BellSouth will translate maintenance requests or responses originating in their internal processes into the agreed upon attributes and elements. Both Parties agree to complete the defined translations, and proceed to systems readiness testing that will result in an operational interface for local service delivery pursuant to Section 4.6.2 of this Attachment. Interprise America and BellSouth agree to adapt the interface based upon evolving standards. To the extent changes to NOF, ECIC or T1M1 standards affect the maintenance and repair functionality for Local Services, the Parties agree to use best efforts to implement such changes, including testing of changes introduced, within 7 months, but not longer than 9 months, of the publication of the standard by the relevant ATIS committee or subcommittee. This preceding target implementation obligation may be modified by mutual agreement.

7. **Electronic Interfaces for Preordering**

7.1 Transaction-Based Information Exchange

7.1.1 When applicable, the Parties agree that preordering information exchange, as defined in Section 4.5 preceding, will be transmitted over the same interface according to the same content definition both for resold BellSouth telecommunications services and for services provided using Network Elements. BellSouth shall expeditiously develop and deploy an on-line electronic means for Interprise America to receive customer service records on a restricted basis that will appropriately safeguard a customer's privacy. This electronic interface must meet Interprise America's needs and also contain such safety provisions or restrictions to make sure that it safeguards customer privacy in an appropriate manner. Interprise America shall not be required to present prior written authorization from each customer to BellSouth before BellSouth allows access to Customer Service Records. Interprise America shall issue a blanket letter of authorization to BellSouth which states that Interprise America will obtain the customer's permission before accessing Customer Service records. BellSouth and Interprise America agree to develop an interface which will insure protection of customer privacy by discouraging roaming through customer information and that only provides the Customer Service Record necessary to provide telecommunications services. BellSouth and Interprise America will communicate and work with the Georgia Consumer Utility Counsel ("CUC") in order to ensure that the arrangements

Interprise America - KY

9/15/97

developed will meet the CUC's privacy concerns related to these matters. The demonstration of the electronic interface methodology and the plan for its deployment shall be presented to the Georgia Public Service Commission and to the CUC so that the CUC may review and provide comments or recommendations to the Commission. If the Commission directs that any changes be made to the initial methodology, or if any subsequent changes be made, or if any subsequent changes are proposed by the Parties, then the entire methodology and plan, including such changes, shall be submitted to the Commission for additional review. The electronic interface shall not be deployed until the Commission has reviewed the methodology and plan according to this procedure.

- 7.1.2 Interprise America and BellSouth will establish a mutually agreed upon transaction-based electronic communications interface for preordering pursuant to Sections 4.6.1 and 4.6.2 of this Attachment. This communications interface will transport the content necessary to perform inquiries for Switch/Feature Availability (on an exception basis when batch feed data is incomplete), Address Verification (on an exception basis when batch feed data is incomplete), Telephone Number Assignment, Appointment Scheduling, and Customer Service Records. Interprise America and BellSouth will exchange transactions over a mutually agreeable X.25 or TCP/IP based network.
 - 7.1.3 Interprise America and BellSouth will translate preordering data elements used in their internal processes into the agreed upon forms and EDI. Both Parties will complete the defined translations, establish query-response cycle time commitments, including but not limited to notification of message acknowledgments and message rejections, and proceed to systems readiness testing, as covered in more detail in Section 8, that will result in a fully operational interface for local service delivery. The implementation date for this interface will be as stated in Section 4.6.2 of this Attachment. This preceding target implementation obligation may be modified by mutual consent.
 - 7.1.4 Interprise America and BellSouth agree to adapt the interface based upon evolving standards. To the extent changes to OBF or SOSC EDI implementation guideline related to preordering functionality, the Parties agree to use best efforts to implement such changes, including testing of the changes introduced within 7 months of the date of published electronic interface standards by the relevant ATIS committee or subcommittee. This preceding target implementation obligation may be modified by mutual agreement.
- 7.2 Batch Data Information Exchange

Interprise America - KY

9/15/97

- 7.2.1 BellSouth will accept Interprise America's request for initial batch feeds of Service/Feature Availability and Regional Street Address Guide (or an equivalent). At a minimum, this batch feed will include the switch/feature availability, information and address information currently provided via the interim interface described in Section 4.5 above.
- 7.2.2 Interprise America and BellSouth will establish a mutually agreeable format for the exchange of batch data no later than 90 days following adoption of this agreement. When the interface is operational, BellSouth will transmit the initial batch feed of the data, relating to the geographic area specified by Interprise America pursuant to a mutually agreed upon schedule. In addition, BellSouth will provide complete refreshes of the data, for the geographic areas cumulatively encompassed by requests from Interprise America, on a mutually agreeable monthly schedule. BellSouth will send the initial batch feed and subsequent monthly updates electronically via a file transfer network (e.g., Network Data Mover Network) using the CONNECT:Direct file transfer product.
- 7.2.3 Interprise America and BellSouth will translate necessary data elements used in their internal processes into mutually agreeable and consistent file formats and record layouts. Both Parties agree to complete development and proceed to systems readiness testing that will result in an operational interface pursuant to Section 4.6.2 of this Attachment. To the extent that an industry forum, committee or subcommittee, under the auspices of ATIS, establishes guidelines and/or standard relating to the batch information data described above, the Parties agree to use best efforts to implement such changes, including testing of the changes introduced, within 7 months of the publication of the standard by the relevant ATIS committee or subcommittee. This preceding target implementation obligation may be modified by mutual agreement.

8. Testing and Acceptance

- 8.1 Interprise America and BellSouth agree that no interface will be considered as operational until end-to-end integrity and load testing, as agreed to in the Joint Implementation Agreement (Section 9), or other mutually acceptable documentation is completed to the satisfaction of both Parties. The intent of the end-to-end integrity testing is to establish, through the submission and processing of test cases, that transactions agreed to by Interprise America and BellSouth will successfully process, in a timely and accurate manner, through both Parties' supporting OSS as well as the interfaces. For transaction-based interfaces, the testing will include the use of mutually agreeable test transactions, designed to represent no less than 85% of the transaction types that Interprise America expects to send and receive through the interface undergoing end-to-end testing.

Interprise America - KY

9/15/97

- 8.2 In addition, Interprise America and BellSouth will establish either a mutually agreeable testing environment or alternative method, such as an audit process, sufficient to demonstrate that the interfaces established between Interprise America and BellSouth have the capability and capacity to exchange busy period transaction volumes reasonably projected to occur during the forward-looking twelve month period following implementation of the interface. This process must validate that Interprise America and BellSouth can accept and process the anticipated busy period load without degradation of overall end-to-end performance of the information exchange even when other CLEC transactions are simultaneously processed by BellSouth.
- 8.3 It is understood by the Parties that End-to-End testing and load testing are necessary processes in the implementation of electronic interfaces and in establishing what further work needs to be done to insure that Interprise America will receive electronic interfaces at parity with what BellSouth provides itself, its Affiliates, and its customers. In no instance will End-to-End testing or load testing processes be short-cut, expedited, or in any other way jeopardized such that the quality of the production implementation is put at risk. It is understood by the Parties that such testing occurs immediately preceding production implementation of electronic interfaces and that in the event of delays by either party End-to-End testing and load testing will not be expedited solely to meet the time frames outlined in this agreement. This implementation obligation may be modified by mutual agreement.
- 8.4 The results of testing will not be shared with other parties without the written consent of Interprise America and BellSouth.

9. **Joint Implementation Agreement Development**

- 9.1 Interprise America and BellSouth agree to document, within 60 days of approval of this Agreement, a project plan for each interface that explicitly identifies all essential activities, sequence and interrelationship of these activities and the target completion dates for each activity identified. The project plans will reflect, on an on-going basis, delivery of target interfaces as discussed and agreed to within each preceding section.
- 9.2 Interprise America and BellSouth recognize that the preceding project plans are not sufficient to fully resolve all technical and operational details related to the interfaces described. Therefore, Interprise America and BellSouth agree to document the additional technical and operational details in the form of a Joint Implementation Agreement (JIA). These JIAs may be modified by mutual agreement of the Parties.

- 9.3 Interprise America and BellSouth agree to document both a topical outline for the JIAs, and establish a schedule for identifying, discussing, resolving and documenting resolution of issues related to each aspect of the JIA topical outline for each interface discussed in this document. In no case will either end-to-end integrity testing or load testing begin without both Parties mutually agreeing that each interface JIA documents the intended operation of the interface scheduled for testing. By mutual agreement, specific paragraphs or entire sections of the overall Agreement may be identified and documented to serve the purpose described for the Joint Implementation Agreement for specific interfaces. Any issues identified and subsequently resolved through either the end-to-end integrity or load testing processes will be incorporated into the impacted interface JIA within 30 days of issue resolution.
- 9.4 Performance measurements shall be established pursuant to Section 12 of the General Terms and Conditions of this Agreement.

10. **Other Agreements**

- 10.1 This Attachment 15 reflects compromises on the part of both Interprise America and BellSouth. By accepting this Attachment 15, Interprise America does not waive its right to non-discriminatory access to Operations Support Systems of BellSouth.
- 10.2 Interprise America and BellSouth agree that the same interfaces will be utilized for all states within the operating area of BellSouth unless the Parties mutually agree to do otherwise.

**Amendment One to Interconnection Agreement
by and between BellSouth Telecommunications, Inc.
and Interprise America**

This Agreement refers to the Interconnection Agreement (“the Agreement”) entered into by U S WEST Interprise America, Inc. (“Interprise America”) and BellSouth Telecommunications, Inc. (“BellSouth”) on September 15, 1997 in the state of Kentucky. This Amendment (“Amendment”) is made by and between Interprise America and BellSouth and shall be deemed effective on the date executed by Interprise America and BellSouth.

NOW THEREFORE, in consideration of the mutual provisions contained herein and other good and valuable consideration, the receipt and sufficiency of which are hereby acknowledged, Interprise America and BellSouth (individually, a “Party” and collectively, the “Parties”) hereby covenant and agree as follows:

1. BellSouth and Interprise America are entering into this Agreement for the purpose of amending section 20.1 of the Terms and Conditions contained in their existing Agreement to allow BellSouth to provide Interprise America subscriber listings contained in BellSouth’s Directory Assistance Database to third parties such as other CLEC’s, Independent Companies and Interexchange Carriers or other telecommunications service providers who may request such information.

2. The Parties agree that all other provisions of the Interconnection Agreement, dated September 15, 1997, shall remain in full force and effect.

3. The Parties further agree that either or both of the Parties is authorized to submit this Amendment to the Kentucky Public Service Commission or other regulatory body having jurisdiction over the subject matter of this Amendment, for approval subject to Section 252(e) of the federal Telecommunications Act of 1996.

IN WITNESS WHEREOF, the parties hereto have caused this Amendment to be executed by their respective duly authorized representatives on the date indicated below.

U S WEST Interprise America, Inc.

BellSouth Telecommunications, Inc.

sd/Mary F. LaFave
Signature

sd/Jerry D. Hendrix
Signature

Mary F. LaFave
Name

Jerry D. Hendrix
Name

Director Regulatory Affairs
Title

Director - Interconnection Services
Title

May 21, 1998
Date

May 27, 1998
Date

**Amendment II-K to Master Interconnection Agreement between
BellSouth Telecommunications, Inc. and
U S WEST Interprise America, Inc.**

Pursuant to this Agreement (the "Amendment"), BellSouth Telecommunications, Inc. ("BellSouth") and U S West Interprise America, Inc. ("Interprise America") hereinafter referred to collectively as the "Parties" hereby agree to amend that certain Interconnection Agreement between the Parties dated September 15, 1997 ("Interconnection Agreement").

NOW THEREFORE, in consideration of the mutual provisions contained herein and other good and valuable consideration, the receipt and sufficiency of which are hereby acknowledged, BellSouth and Interprise America hereby covenant and agree as follows:

1. Pursuant to Section 42 in the General Terms & Conditions of the Interconnection Agreement, the parties hereby agree to revise the Unbundled Network Element Rates and Local Interconnection Rates as set forth in Tables 1, 3, 4, 5 and 6 of the General Terms & Conditions for the state of Kentucky. Based on the Order issued by the Kentucky Public Service Commission on July 14, 1997 in Docket No. 96-482, the final unbundled network element rates and local interconnection rates in Kentucky shall be as set forth in the attachment. These rates shall be applied on a prospective basis pursuant to Section 42 in the General Terms & Conditions of the Interconnection Agreement.

2. The Parties agree that Tables 1, 3, 4, 5 and 6 of the General Terms & Conditions for the state of Kentucky are hereby deleted in their entirety and replaced with a new Attachment 11 for the state of Kentucky attached hereto to reflect the new arbitrated rates in the state of Kentucky.

3. The Parties agree that all of the other provisions of the Interconnection Agreement, dated September 15, 1997, shall remain in full force and effect.

4. The Parties further agree that either or both of the Parties is authorized to submit this Amendment to the Kentucky Public Service Commission or other regulatory body having jurisdiction over the subject matter of this Amendment, for approval subject to Section 252(e) of the federal Telecommunications Act of 1996.

IN WITNESS WHEREOF, the Parties hereto have caused this Amendment to be executed by their respective duly authorized representatives on the date indicated below.

U S WEST Interprise America, Inc.

BellSouth Telecommunications, Inc.

By: _____

By: _____

Name: _____

Name: Jerry D. Hendrix

Title: _____

Title: Director-Interconnection Services

Date: _____

Date: _____

DUPLICATE ORIGINAL

KENTUCKY

PRICING

1. General Principles

All services currently provided hereunder (including resold Local Services, Network Elements and Ancillary Functions) and all new and additional services to be provided hereunder shall be priced in accordance with all applicable provisions of the Act and the rules and orders of the Federal Communications Commission and Kentucky Public Service Commission.

2. Local Service Resale

The rates that CLEC shall pay to BellSouth for resold Local Services shall be BellSouth's Retail Rates less the applicable discount. The following discount will apply to all Telecommunications Services available for resale in Kentucky.

Residential Service	16.79%
Business Service:	15.54%

3. Unbundled Network Elements

The prices that CLEC shall pay to BellSouth for Unbundled Network Elements are set forth in Table 1.

4. Compensation For Local Interconnection (Call Transport and Termination)

The prices that CLEC and BellSouth shall pay each other for the termination of local calls are set forth in Table 1.

5. Ancillary Functions

5.1 Collocation - The rates, terms and conditions for Physical Collocation are as set forth in Attachment 4 of this Agreement. These rates are regional rates and shall apply for all nine states. Rates, terms, and conditions for Virtual Collocation are as set forth in Section 20 of BellSouth Telecommunications, Inc.'s Interstate Access Tariff, FCC No. 1.

5.2 Poles, Ducts and Conduits - BellSouth shall provide access to poles, conduits and ducts at rates that are consistent with 47 U.S.C. Section 224(d). CLEC may file a complaint with the appropriate regulatory authority if it believes the rates provided by BellSouth are not consistent with 47 U.S.C. Section 224(d).

6. **Dark Fiber**

The prices for Dark Fiber are set forth in Table 1.

7. **Local Number Portability**

The prices for interim number portability are set forth in Table 1.

8. **Recorded Usage Data**

The prices for recorded usage data are set forth in Table 1.

9. **Electronic Interfaces**

All costs incurred by BellSouth to implement operational interfaces shall be recovered from the CLECs on a fairly apportioned basis. If there is disagreement between the Parties regarding cost recovery issues, an affected party may petition the Kentucky Public Service Commission to initiate a separate hearing to address the matter.

10. **Operational Support Systems (OSS) Rates**

Rates for OSS are as set forth in Table 1. In addition to OSS charges, applicable service order and related charges apply per the tariff.

TABLE 1

**BELLSOUTH/CLEC RATES - KENTUCKY
 LOCAL INTERCONNECTION AND UNBUNDLED NETWORK ELEMENTS**

NIDs	
NRC - NID per 2-Wire Loops--Incremental--Manual Svc Order--1st	NA
NRC - NID per 2-Wire Loops--Incremental--Manual Svc Order--Add'l	NA
NRC - NID per 2-Wire Loops--Incremental--Manual Svc Order--Disconnect	NA
NRC - NID per 4-Wire Loops--Incremental--Manual Svc Order--1st	NA
NRC - NID per 4-Wire Loops--Incremental--Manual Svc Order--Add'l	NA
NRC - NID per 4-Wire Loops--Incremental--Manual Svc Order--Disconnect	NA
NID (all types), per month	\$1.80
Installation of 2-Wire/4-Wire CLEC NID, NRC-1 st	NA
Installation of 2-Wire/4-Wire CLEC NID, NRC-Add'l	NA
NID to NID Cross Connect, 2-Wire or 4-Wire, NRC	NA
NID per 2-Wire Analog VG Loop, Per Month	NA
NRC - 1 st	NA
NRC - Add'l	NA
NRC - Disconnect Chg - 1st	NA
NRC - Disconnect Chg - Add'l	NA
NID per 4-Wire Analog VG Loop, Per Month	NA
NRC - 1 st	NA
NRC - Add'l	NA
NRC - Disconnect Chg - 1st	NA
NRC - Disconnect Chg - Add'l	NA
NID per 2-Wire ISDN Digital VG Loop, Per Month	NA
NRC - 1 st	NA
NRC - Add'l	NA
NRC - Disconnect Chg - 1st	NA
NRC - Disconnect Chg - Add'l	NA
NID per 2-Wire Asymmetrical Dig Subscriber Line (ADSL) Loop, Per Mo.	NA
NRC - 1 st	NA
NRC - Add'l	NA
NRC - Disconnect Chg - 1st	NA
NRC - Disconnect Chg - Add'l	NA
NID per 2-Wire High Bit Rate Dig Subscriber Line (HDSL) Loop	NA
NRC - 1 st	NA
NRC - Add'l	NA
NRC - Disconnect Chg - 1st	NA
NRC - Disconnect Chg - Add'l	NA
NID per 4-Wire High Bit Rate Dig Subscriber Line (HDSL) Loop	NA
NRC - 1 st	NA
NRC - Add'l	NA
NRC - Disconnect Chg - 1st	NA
NRC - Disconnect Chg - Add'l	NA
NID per 4-Wire 56 or 64 Kbps Dig Grade Loop	NA
NRC - 1 st	NA
NRC - Add'l	NA
NRC - Disconnect Chg - 1st	NA
NRC - Disconnect Chg - Add'l	NA
Nonrecurring Charge - customer transfer, feature additions, changes (1)	NA

LOOP, EXCLUDING NID	
2-Wire Analog VG Loop (Standard), per month	\$18.20
NRC - 1 st	\$86.08
NRC - Add'l	\$58.57
2-Wire Analog VG Loop (Customized), per month	\$21.41
NRC - 1 st	\$236.75
NRC - Add'l	\$177.10
4-Wire Analog VG Loop (Standard), per month	\$26.38
NRC - 1 st	\$457.14
NRC - Add'l	\$348.83
2-Wire ISDN Digital Grade Loop (Standard), per month	\$29.65
NRC - 1 st	\$541.28
NRC - Add'l	\$431.61
2-Wire ADSL Loop (Standard), per month	\$10.63
NRC - 1 st	\$713.50
NRC - Add'l	\$609.44
2-Wire HDSL Loop (Standard), per month	\$7.40
NRC - 1 st	\$713.50
NRC - Add'l	\$609.44
4-Wire HDSL Loop (Standard), per month	\$9.70
NRC - 1 st	\$748.93
NRC - Add'l	\$646.17
LOOP, INCLUDING NID	
2-Wire Analog VG Loop, per month	NA
NRC - 1 st	NA
NRC - Add'l	NA
2-Wire Analog VG Loop-SL1, per month	NA
NRC - 1 st	NA
NRC - Add'l	NA
NRC - Incremental Charge--Manual Service Order—1 st	NA
NRC - Incremental Charge--Manual Service Order—Add'l	NA
NRC - Incremental Charge—Manual Svc Order—Disconnect	NA
NRC - Disconnect Chg - 1 st	NA
NRC - Disconnect Chg - Add'l	NA
NRC - Order Coordination for Specified Conversion Time	NA
2-Wire Analog VG Loop-SL1-Manual Order Coord	
NRC - 1 st	NA
NRC - Add'l	NA
NRC - Disconnect Chg - 1st	NA
NRC - Disconnect Chg - Add'l	NA
2-Wire Analog VG Loop-SL2, per month	NA
NRC - 1 st	NA
NRC - Add'l	NA
NRC - Incremental Charge--Manual Service Order—1 st	NA
NRC - Incremental Charge--Manual Service Order—Add'l	NA
NRC - Incremental Charge—Manual Svc Order—Disconnect	NA
NRC - Disconnect Chg - 1 st	NA
NRC - Disconnect Chg - Add'l	NA
NRC - Order Coordination for Specified Conversion Time	\$55.00
2-Wire Analog VG Loop (Standard), per month	\$20.00
NRC - 1 st	\$86.08

NRC - Add'l	\$58.57
2-Wire Analog VG Loop (Customized), per month	\$23.35
NRC - 1 st	\$236.75
NRC - Add'l	\$177.10
4-Wire Analog VG Loop, per month	NA
NRC - 1 st	NA
NRC - Add'l	NA
NRC - Incremental Charge--Manual Service Order—1 st	NA
NRC - Incremental Charge--Manual Service Order—Add'l	NA
NRC - Incremental Charge—Manual Svc Order—Disconnect	NA
NRC - Disconnect Chg - 1 st	NA
NRC - Disconnect Chg - Add'l	NA
NRC - Order Coordination for Specified Conversion Time	NA
4-Wire Analog VG Loop (Standard), per month	\$28.28
NRC - 1 st	\$457.14
NRC - Add'l	\$348.83
2-Wire ISDN Digital Grade Loop, per month	NA
NRC - 1 st	NA
NRC - Add'l	NA
NRC - Incremental Charge--Manual Service Order—1 st	NA
NRC - Incremental Charge--Manual Service Order—Add'l	NA
NRC - Incremental Charge—Manual Svc Order—Disconnect	NA
NRC - Disconnect Chg - 1 st	NA
NRC - Disconnect Chg - Add'l	NA
NRC - Order Coordination for Specified Conversion Time	NA
2-Wire ISDN Digital Grade Loop (Standard), per month	\$31.99
NRC - 1 st	\$541.28
NRC - Add'l	\$431.61
2-Wire Asymmetrical Dig Subscriber Line (ADSL) Compatible Loop, per month	NA
NRC - 1 st	NA
NRC - Add'l	NA
NRC - Incremental Charge--Manual Service Order—1 st	NA
NRC - Incremental Charge--Manual Service Order—Add'l	NA
NRC - Incremental Charge—Manual Svc Order—Disconnect	NA
NRC - Disconnect Chg - 1 st	NA
NRC - Disconnect Chg - Add'l	NA
NRC - Order Coordination for Specified Conversion Time	NA
2-Wire ADSL Loop (Standard), per month	\$11.89
NRC - 1 st	\$713.50
NRC - Add'l	\$609.44
2-Wire Asymmetrical Dig Subscriber Line (ADSL) ISDN Loop, per month	NA
NRC - 1 st	NA
NRC - Add'l	NA
2-Wire High Bit Rate Dig Subscriber Line (HDSL) Compatible Loop, per month	NA
NRC - 1 st	NA
NRC - Add'l	NA
NRC - Incremental Charge--Manual Service Order—1 st	NA
NRC - Incremental Charge--Manual Service Order—Add'l	NA
NRC - Incremental Charge—Manual Svc Order—Disconnect	NA
NRC - Disconnect Chg - 1 st	NA
NRC - Disconnect Chg - Add'l	NA
NRC - Order Coordination for Specified Conversion Time	NA
2-Wire HDSL Loop (Standard), per month	\$8.51

NRC - 1 st	\$713.50
NRC - Add'l	\$609.44
4-Wire High Bit Rate Dig Subscriber Line (HDSL) Compatible Loop, per month	NA
NRC - 1 st	NA
NRC - Add'l	NA
NRC - Incremental Charge--Manual Service Order—1 st	NA
NRC - Incremental Charge--Manual Service Order—Add'l	NA
NRC - Incremental Charge—Manual Svc Order—Disconnect	NA
NRC - Disconnect Chg - 1st	NA
NRC - Disconnect Chg - Add'l	NA
NRC - Order Coordination for Specified Conversion Time	NA
4-Wire HDSL Loop (Standard), per month	\$10.39
NRC - 1 st	\$748.93
NRC - Add'l	\$646.17
4-Wire DS1 Digital Loop, per month	\$67.96
NRC - 1 st	\$849.80
NRC - Add'l	\$523.27
NRC - Disconnect Chg - 1st	NA
NRC - Disconnect Chg - Add'l	NA
NRC - Incremental Charge--Manual Svc Order-1st	NA
NRC - Incremental Charge--Manual Svc Order-Add'l	NA
NRC - Incremental Charge--Manual Svc Order-Disconnect	NA
NRC - Order Coordination for Specified Conversion Time	NA
4-Wire 56 or 64 Kbps Dig Grade Loop, per month	NA
NRC - 1 st	NA
NRC - Add'l	NA
NRC - Incremental Charge--Manual Service Order—1 st	NA
NRC - Incremental Charge--Manual Service Order—Add'l	NA
NRC - Incremental Charge—Manual Svc Order—Disconnect	NA
NRC - Disconnect Chg - 1st	NA
NRC - Disconnect Chg - Add'l	NA
NRC - Order Coordination for Specified Conversion Time	NA
Unbundled Loops via IDLC	NA
SUB-LOOPS	
Sub-Loop 2-Wire Analog	
Loop Feeder per 2-Wire Analog VG Loop, per month	NA
NRC - 1 st	NA
NRC - Add'l	NA
NRC - Incremental Charge--Manual Service Order—1 st	NA
NRC - Incremental Charge--Manual Service Order—Add'l	NA
NRC - Disconnect Chg - 1 st	NA
NRC - Disconnect Chg - Add'l	NA
NRC - Order Coordination for Specified Conversion Time	NA
Loop Distribution per 2-Wire Analog VG Loop (Including NID), per month	\$10.83
NRC - 1 st	\$459.85
NRC - Add'l	\$352.89
NRC - Incremental Charge--Manual Service Order—1 st	NA
NRC - Incremental Charge--Manual Service Order—Add'l	NA
NRC - Incremental Charge—Manual Svc Order—Disconnect	NA
NRC - Disconnect Chg - 1 st	NA
NRC - Disconnect Chg - Add'l	NA

NRC - Order Coordination for Specified Conversion Time	NA
Loop Distribution per 2-Wire Analog VG Loop (Excluding NID), per month	\$9.95
NRC - 1 st	\$459.85
NRC - Add'l	\$352.89
Loop Distribution per 4-Wire Analog VG Loop (Incl NID), per month	NA
NRC - 1 st	NA
NRC - Add'l	NA
Unbundled Network Terminating Wire	
UNTW Pair, per pair, per month	\$2.00
Site Visit Survey, per MDU/MTU Complex, NRC	\$225.00
Site Visit Set-Up – Terminal Preparation, per terminal	
NRC - 1 st terminal	\$98.00
NRC – add'l terminal	\$65.00
Access Terminal Provisioning & 1 st 25 pair panel, per terminal, NRC	\$110.00
Existing Access Terminal Provisioning, 2 nd 25 pair panel, per terminal, NRC	\$35.00
UNTW Pair Provisioning, per pair, NRC	\$9.00
Service Visit for Provisioning, per request, per premises, NRC	\$55.00
Manual Service Order, NRC	\$45.00
Loop Concentration - Channelization Sys (Outside CO), per month	\$263.06
NRC - 1 st	\$1,508.41
NRC - Add'l	\$596.11
NRC - Disconnect Chg - 1 st	NA
NRC - Disconnect Chg - Add'l	NA
NRC - Incremental Charge--Manual Svc Order - 1 st	NA
NRC - Incremental Charge--Manual Svc Order - Add'l	NA
NRC - Incremental Charge--Manual Svc Order - Disconnect	NA
Working Plug-In 2-Wire, NRC 1 st	\$23.30
Working Plug-In 2-Wire, NRC Add'l	\$23.25
Loop Concentration - Remote Terminal Cabinet (Outside CO)	ICB
Loop Concentration - Remote Channel Interface - 2-Wire VG (Outside CO), per month	NA
NRC - 1 st	NA
NRC - Add'l	NA
NRC - Incremental Charge--Manual Service Order—1 st	NA
NRC - Incremental Charge--Manual Service Order—Add'l	NA
NRC - Incremental Charge—Manual Svc Order—Disconnect	NA
NRC - Disconnect Chg - 1 st	NA
NRC - Disconnect Chg - Add'l	NA
Loop Channelization System (Inside C.O.)	
Loop Channelization Sys-Dig Loop Carrier per Mo. (DS1 to VG), per month	\$429.33
NRC - 1 st	\$664.06
NRC - Add'l	\$166.55
NRC - Disconnect Chg - 1st	NA
NRC - Disconnect Chg - Add'l	NA
NRC - Incremental Charge--Manual Svc Order - 1st	NA
NRC - Incremental Charge--Manual Svc Order - Add'l	NA
NRC - Incremental Charge--Manual Svc Order - Disconnect	NA
CO Channel Interface-2-Wire VG Per Circuit, Per Month	\$1.26
NRC - 1 st	\$46.68
NRC - Add'l	\$46.38
NRC-Incremental Charge--Manual Svc Order-1 st	NA
NRC-Incremental Charge--Manual Svc Order-Add'l	NA
NRC - Incremental Charge—Manual Svc Order—Disconnect	NA

NRC - Disconnect Chg - 1st	NA
NRC - Disconnect Chg - Add'l	NA
UNBUNDLED LOCAL EXCHANGE SWITCHING (PORTS)	
2-Wire Analog Line Port (Res., Bus.), per month	\$2.61
NRC - 1 st (all types)	NA
NRC - Add'l (all types)	NA
NRC - 1 st (Residence)	\$37.78
NRC - Add'l (Residence)	\$37.78
NRC - 1 st (Business)	\$37.55
NRC - Add'l (Business)	\$37.55
NRC - 1 st (PBX)	\$36.47
NRC - Add'l (PBX)	\$36.47
NRC - Disconnect Chg - 1st	NA
NRC - Disconnect Chg - Add'l	NA
NRC - Incremental Charge--Manual Svc Order - 1st	NA
NRC - Incremental Charge--Manual Svc Order - Add'l	NA
NRC - Incremental Charge--Manual Svc Order - Disconnect	NA
4-Wire Analog VG Port, per month	NA
NRC - 1 st	NA
NRC - Add'l	NA
NRC - Disconnect Chg - 1st	NA
NRC - Disconnect Chg - Add'l	NA
NRC - Incremental Charge--Manual Svc Order - 1st	NA
NRC - Incremental Charge--Manual Svc Order - Add'l	NA
NRC - Incremental Charge--Manual Svc Order - Disconnect	NA
2-Wire DID Port, per month	NA
NRC - 1 st	NA
NRC - Add'l	NA
NRC - Disconnect Chg - 1st	NA
NRC - Disconnect Chg - Add'l	NA
NRC - Incremental Charge--Manual Svc Order - 1st	NA
NRC - Incremental Charge--Manual Svc Order - Add'l	NA
NRC - Incremental Charge--Manual Svc Order - Disconnect	NA
4-Wire DID Port, per month	NA
NRC - 1 st	NA
NRC - Add'l	NA
NRC - Disconnect Chg - 1st	NA
NRC - Disconnect Chg - Add'l	NA
NRC - Incremental Charge--Manual Svc Order - 1st	NA
NRC - Incremental Charge--Manual Svc Order - Add'l	NA
NRC - Incremental Charge--Manual Svc Order - Disconnect	NA
4-Wire DS1 Port w/DID capability, per month	NA
NRC - 1 st	NA
NRC - Add'l	NA
2-Wire ISDN Port(2) (3), per month	\$12.33
NRC - 1 st	\$90.48
NRC - Add'l	\$84.53
NRC - Disconnect Chg - 1st	NA
NRC - Disconnect Chg - Add'l	NA
NRC - Incremental Charge--Manual Svc Order - 1st	NA
NRC - Incremental Charge--Manual Svc Order - Add'l	NA
NRC - Incremental Charge--Manual Svc Order-Disconnect 1st	NA
NRC - Incremental Charge--Manual Svc Order-Disconnect Add'l	NA

NRC - User Profile per B Channel (4)	\$5.61
4-Wire ISDN Port, per month	NA
NRC - 1 st	NA
NRC - Add'l	NA
NRC - Disconnect Chg - 1st	NA
NRC - Disconnect Chg - Add'l	NA
NRC - Incremental Charge--Manual Svc Order - 1st	NA
NRC - Incremental Charge--Manual Svc Order - Add'l	NA
NRC - Incremental Charge--Manual Svc Order-Disconnect 1st	NA
NRC - Incremental Charge--Manual Svc Order-Disconnect Addl	NA
4-Wire ISDN DS1 Port, per month	\$275.48
NRC - 1 st	\$181.27
NRC - Add'l	\$116.42
NRC - Disconnect Chg - 1st	NA
NRC - Disconnect Chg - Add'l	NA
NRC - Incremental Charge--Manual Svc Order - 1st	NA
NRC - Incremental Charge--Manual Svc Order - Add'l	NA
NRC - Incremental Charge--Manual Svc Order-Disconnect 1st	NA
NRC - Incremental Charge--Manual Svc Order-Disconnect Addl	NA
2-Wire Analog Line Port (PBX), per month	NA
NRC - 1 st	NA
NRC - Add'l	NA
NRC - Disconnect Chg - 1st	NA
NRC - Disconnect Chg - Add'l	NA
NRC - Incremental Charge--Manual Svc Order - 1st	NA
NRC - Incremental Charge--Manual Svc Order - Add'l	NA
NRC - Incremental Charge--Manual Svc Order-Disconnect	NA
2-Wire Analog Hunting, per line per month	\$0.29
NRC - 1 st	\$2.14
NRC - Add'l	\$2.14
Coin Port, per month	\$3.04
NRC - 1 st	\$40.71
NRC - Add'l	\$40.71
NRC - Disconnect Chg - 1 st	NA
NRC - Disconnect Chg - Add'l	NA
NRC - Incremental Charge--Manual Svc Order - 1 st	NA
NRC - Incremental Charge--Manual Svc Order - Add'l	NA
NRC - Incremental Charge--Manual Svc Order-Disconnect	NA
Vertical Features	
Local Switching Features offered with Port, Per month	No add'l charge
Subsequent Order Charge—Electronic	NA
Subsequent Order Charge--Incremental Charge--Manual Svc Order	NA
Unbundled End Office Switching (Port Usage)	
End Office Switching Function, per mou	\$0.002562
End Office Switching Function, add'l mou (5)	NA
End Office Interoffice Trunk Port—Shared, per mou	NA
Unbundled Tandem Switching (Port Usage) (Local or Access Tandem)	
Tandem Switching Function per mou	\$0.001096
Tandem Interoffice Trunk Port—Shared per mou	NA
Tandem Intermediary Charge, per mou (This charge is applicable only to intermediary traffic and is applied in addition to applicable switching and/or inter-connection charges.)	\$0.001096

UNBUNDLED TRANSPORT	
Common (Shared) Transport	
Common (Shared) Transport per mile per mou	\$0.0000049
Common (Shared) Transport Facilities Termination per mou	\$0.000426
Interoffice Transport - Dedicated - VG	
Interoffice Transport - Dedicated - 2-Wire VG - per mile	NA
Interoffice Transport - Dedicated - 2-Wire VG - facilities termination per month	NA
NRC - 1 st	NA
NRC - Add'l	NA
NRC - Disconnect Chg - 1st	NA
NRC - Disconnect Chg - Add'l	NA
NRC - Incremental Charge--Manual Svc Order - 1st	NA
NRC - Incremental Charge--Manual Svc Order - Add'l	NA
NRC - Incremental Charge--Manual Svc Order-Disconnect--1st	NA
NRC - Incremental Charge--Manual Svc Order-Disconnect--Addl	NA
Interoffice Transport - Dedicated - DS0 - 56/64 KBPS	
Interoffice Transport - Dedicated - DS0 - per mile per month	NA
Interoffice Transport - Dedicated - DS0 - facilities termination per month	NA
NRC - 1 st	NA
NRC - Add'l	NA
NRC - Disconnect Chg - 1st	NA
NRC - Disconnect Chg - Add'l	NA
NRC - Incremental Charge--Manual Svc Order - 1st	NA
NRC - Incremental Charge--Manual Svc Order - Add'l	NA
NRC - Incremental Charge--Manual Svc Order-Disconnect--1st	NA
NRC - Incremental Charge--Manual Svc Order-Disconnect--Addl	NA
Interoffice Transport - Dedicated - DS1	
Interoffice Transport - Dedicated - DS1 - per mile per month	\$0.45
Interoffice Transport - Dedicated - DS1 - facilities termination per month	\$55.05
NRC - 1 st	\$298.18
NRC - Add'l	\$231.23
NRC - Disconnect Chg - 1st	NA
NRC - Disconnect Chg - Add'l	NA
NRC - Incremental Charge--Manual Svc Order - 1st	NA
NRC - Incremental Charge--Manual Svc Order - Add'l	NA
NRC - Incremental Charge--Manual Svc Order-Disconnect--1st	NA
NRC - Incremental Charge--Manual Svc Order-Disconnect--Addl	NA
Interoffice Transport - Dedicated - DS3	
Interoffice Transport - Dedicated - DS3 - per mile per month	NA
Interoffice Transport - Dedicated - DS3 - facilities termination per month	NA
NRC - 1 st	NA
NRC - Add'l	NA
Unbundled Exchange Access IOC	
0-8 Miles, Fixed per month	\$16.14
Per mile per month	\$0.0301
NRC - 1st	\$181.93
NRC - Add'l	\$75.56
9-25 Miles, Fixed per month	\$17.18
Per mile per month	\$0.0726
NRC - 1st	\$181.93
NRC - Add'l	\$75.56
Over 25 Miles, Fixed per month	\$18.41
Per mile per month	\$0.0831

NRC - 1st	\$181.93
NRC - Add'l	\$75.56
Local Channel - Dedicated	
Local Channel - Dedicated - 2-Wire VG	NA
NRC - 1 st	NA
NRC - Add'l	NA
NRC - Disconnect Chg - 1st	NA
NRC - Disconnect Chg - Add'l	NA
NRC - Incremental Charge--Manual Svc Order - 1st	NA
NRC - Incremental Charge--Manual Svc Order - Add'l	NA
NRC - Incremental Charge--Manual Svc Order-Disconnect	NA
Local Channel - Dedicated - 4-Wire VG	NA
NRC - 1 st	NA
NRC - Add'l	NA
NRC - Disconnect Chg - 1 st	NA
NRC - Disconnect Chg - Add'l	NA
NRC - Incremental Charge—Manual Svc Order - 1st	NA
NRC - Incremental Charge—Manual Svc Order - Add'l	NA
NRC - Incremental Charge—Manual Svc Order-Disconnect	NA
Local Channel - Dedicated - DS1	NA
NRC - 1 st	NA
NRC - Add'l	NA
NRC - Disconnect Chg - 1 st	NA
NRC - Disconnect Chg - Add'l	NA
NRC - Incremental Charge—Manual Svc Order	NA
NRC - Incremental Charge—Manual Svc Order-Disconnect	NA
VIRTUAL COLLOCATION	
Virtual Collocation	BST Tariff Rates
LOCAL USAGE	
Intraoffice per mou	NA
Interoffice per mou (assumes 5 miles of transport)	NA
LOCAL INTERCONNECTION (CALL TRANSPORT AND TERMINATION)	
End Office Switching, per mou	\$0.002562
Tandem Switching, per mou	\$0.001096
Tandem Switching (assumes 5 miles of transport per mou)	NA
Transport	UNE prices for shared/ common and dedicated transport apply as appropriate.
All terms and conditions, as well as charges, both non-recurring and recurring, associated with interconnecting trunk groups between BellSouth and CLEC-1 shall be as set forth in Section E.6 of the appropriate BellSouth intrastate access tariff.	BST State Access Tariff Rates
Tandem Switch + Transport	NA
Combined Tandem Switch Interconnection	NA
Multi-tandem Interconnection	NA
800 ACCESS TEN DIGIT SCREENING SERVICE	
800 Access Ten Digit Screening (all types), per call (6)	NA

800 Access Ten Digit Screening Svc. W/800 No. Delivery, per query	\$0.0010
800 Access Ten Digit Screening Svc. W/800 No. Delivery, for 800 Numbers, w/Optional Complex Features, per query	\$0.0011
800 Access Ten Digit Screening Svc. W/POTS No. Delivery, per query	\$0.0010
800 Access Ten Digit Screening Svc. W/POTS No. Delivery, w/Optional Complex Features, per query	\$0.0011
800 Access Ten Digit Screening Svc. W/800 No. Delivery, per message	NA
800 Access Ten Digit Screening Svc. W/800 No. Delivery, for 800 Numbers, w/Optional Complex Features, per message	NA
800 Access Ten Digit Screening Svc. W/POTS No. Delivery, per message	NA
800 Access Ten Digit Screening Svc. W/POTS No. Delivery, w/Optional Complex Features, per message	NA
Reservation Charge per 800 number reserved--NRC - 1st	\$10.05
Reservation Charge per 800 number reserved--NRC - Add'l	\$1.19
NRC - Incremental Charge--Manual Service Order—1 st	NA
NRC - Incremental Charge--Manual Service Charge—Add'l	NA
Per 800 # Established w/o POTS (w/800 No.) Translations	
NRC - 1 st	\$30.59
NRC - Add'l	\$3.22
NRC - Incremental Charge--Manual Service Order—1 st	NA
NRC - Incremental Charge--Manual Service Order—Add'l	NA
NRC - Disconnect Chg - 1 st	NA
NRC - Disconnect Chg - Add'l	NA
Per 800 # Established with POTS Translations	
NRC - 1 st	\$30.59
NRC - Add'l	\$3.22
NRC - Incremental Charge--Manual Service Charge—1 st	NA
NRC - Incremental Charge--Manual Service Charge—Add'l	NA
NRC - Disconnect Chg - 1 st	NA
NRC - Disconnect Chg - Add'l	NA
Customized Area of Service per 800 Number	
NRC - 1 st	\$6.97
NRC - Add'l	\$3.49
NRC - Incremental Charge--Manual Service Order—1 st	NA
NRC - Incremental Charge--Manual Service Order—Add'l	NA
Multiple Inter LATA Carrier Routing per Carrier Requested per 800 #	
NRC - 1 st	\$8.16
NRC - Add'l	\$4.67
NRC - Incremental Charge--Manual Service Charge—1 st	NA
NRC - Incremental Charge--Manual Service Charge—Add'l	NA
Change Charge per request	
NRC - 1 st	\$11.24
NRC - Add'l	\$1.19
NRC - Incremental Charge--Manual Service Charge—1 st	NA
NRC - Incremental Charge--Manual Service Charge—Add'l	NA
Call Handling and Destination Features - NRC-1 st	\$6.97
Call Handling and Destination Features - NRC-Add'l	\$6.97
NRC - Incremental Charge--Manual Service Charge—1 st	NA
NRC - Incremental Charge--Manual Service Charge—Add'l	NA
Reserv Chg per 800 # Reserved - Incrm Charge-Manual Svc Order	NA
Per 800 # Est'd w/o POTS Transl-Incrm Charge-Manual Svc Order	
NRC	NA
NRC - Disconnect Chg	NA

Per 800 # Est'd with POTS Transl-Incrm Charge Manual Svc Order	
NRC	NA
NRC - Disconnect Chg	NA
Chng Chrg/Request-Incrm Charge-Manual Svc Order-NRC	NA
LINE INFORMATION DATABASE ACCESS (LIDB)	
LIDB Common Transport per query	\$0.00006
LIDB Validation per query	\$0.00938
LIDB Validation per message	NA
LIDB Originating Point Code Establishment or Change - NRC	\$107.60
NRC-Incremental Charge-Manual Service Order	NA
LIDB - Incremental Charge - Manual Svc Order - NRC	NA
CCS7 SIGNALING TRANSPORT SERVICE	
CCS7 Signaling Connection, per link (A link) per month	\$16.31
NRC	\$354.95
NRC-Incremental Charge-Manual Service Order	NA
NRC - Disconnect	NA
CCS7 Signaling Connection, per link (B link) (also known as D link) per month	\$16.31
NRC	\$354.95
NRC-Incremental Charge-Manual Service Order	NA
NRC - Disconnect	NA
CCS7 Signaling Termination, per STP port per month	\$174.08
CCS7 Signaling Usage, per ISUP message*	\$0.000037893
CCS7 Signaling Usage, per TCAP message*	\$0.000102042
CCS7 Signaling Usage Surrogate, per link per LATA per mo (7)**	\$329.98
* applicable when measurement and billing capability exists.	
** not applicable when measurement and billing capability exists.	
CCS7 Signaling Point Code, Establishment or Change, per STP affected	
NRC	\$62.00
CCS7 Signaling - Incremental Charge - Manual Svc Order	
NRC	NA
NRC - Disconnect	NA
OPERATIONAL SUPPORT SYSTEMS	
OSS Interactive Ordering and Trouble Maint, Estab, per user per month	\$50.00
NRC	\$100.00
OSS OLEC Daily Usage File: Recording, per message	\$0.0008611
OSS OLEC Daily Usage File: Message Processing, per message	\$0.0032357
OSS Access Daily Usage File: Message Processing, per message	\$0.004
OSS OLEC Daily Usage File: Message Processing, per magnetic tape provisioned	\$55.68
OSS Access Daily Usage File: Message Processing, per magnetic tape provisioned	\$54.95
OSS OLEC Daily Usage File: Data Transmission (CONNECT:DIRECT), per message	\$0.0000365
OSS Access Daily Usage File: Data Transmission (CONNECT:DIRECT), per message	\$0.001
OSS Order Charge, per 1,000 LSRs received from the CLEC by one of the OSS interactive interfaces, per month (per CLEC basis)	
First 1,000 LSRs received	NA
OSS Order Charge, 1,000 LSRs received from the CLEC by one of the OSS interactive interfaces, per month (per CLEC basis)	
Each additional 1,000 LSRs received	NA
OSS Order charge, per LSR received from the CLEC by one of the OSS interactive interfaces	\$10.89
Incremental charge per LSR received from the CLEC by means other than one of the OSS interactive interfaces	\$22.00
OPERATOR CALL PROCESSING	
Operator Provided Call Handling per min - Using BST LIDB	\$1.6016

Call Completion Access Termination Charge per call attempt	NA
Operator Provided Call Handling per min - Using Foreign LIDB	\$1.6249
Call Completion Access Termination Charge per call attempt	NA
Operator Provided Call Handling, per call	NA
Fully Automated Call Handling per call - Using BST LIDB	\$0.0856
Fully Automated Call Handling per call - Using Foreign LIDB	\$0.1071
INWARD OPERATOR SERVICES	
Verification, per minute	NA
Verification and Emergency Interrupt, per minute	NA
Verification, per call	\$1.00
Verification and Emergency Interrupt, per call	\$1.111
DIRECTORY ASSISTANCE SERVICES	
Directory Assist Call Completion Access Svc (DACC), per call attempt	\$0.058
Call Completion Access Term charge per completed call	NA
Number Services Intercept per query	\$0.0086
Number Services Intercept per Intercept Query Update	\$0.0055
Directory Assistance Access Service Calls, per call	\$0.3136
Recording charge per announcement	\$1,664.89
NRC - Incremental Charge--Manual Service Order—1 st	NA
NRC - Incremental Charge--Manual Service Order—Add'l	NA
Loading charge per audio unit	\$244.04
NRC-Incremental Charge-Manual Service Order	
Directory Transport	
Directory Transport - Local Channel DS1, per month	\$36.32
NRC - 1 st	\$637.46
NRC - Add'l	\$546.94
NRC - Disconnect Chg - 1st	NA
NRC - Disconnect Chg - Add'l	NA
NRC - Incremental Charge-Manual Svc Order - NRC	NA
NRC - Incremental Charge-Manual Svc Order - NRC-Disconnect	NA
Directory Transport - Dedicated DS1 Level Interoffice per mile per mo	\$0.45
Directory Transport - Dedicated DS1 Level Interoffice per facility termination per mo	\$55.05
NRC - 1 st	\$298.18
NRC - Add'l	\$231.18
NRC - Disconnect Chg - 1 st	NA
NRC - Disconnect Chg - Add'l	NA
NRC - Incremental Charge-Manual Svc Order - NRC-1 st	NA
NRC - Incremental Charge-Manual Svc Order - NRC-Add'l	NA
NRC - Incremental Charge-Manual Svc Order - NRC-Disconnect-1 st	NA
NRC - Incremental Charge-Manual Svc Order - NRC-Disconnect-Add'l	NA
Switched Common Transport per DA Access Service per call	\$0.000175
Switched Common Transport per DA Access Service per call per mile	\$0.000004
Access Tandem Switching per DA Access Service per call	\$0.000783
DA Interconnection, per DA Access Service Call	NA
Directory Transport-Installation NRC, per trunk or signaling connection	
NRC - 1 st	\$501.98
NRC - Add'l	\$13.32
NRC - Incremental Charge--Manual Service Order—1 st	NA
NRC - Incremental Charge--Manual Service Order—Add'l	NA
NRC - Disconnect Chg - 1st	NA
NRC - Disconnect Chg - Add'l	NA
Directory Assistance Database Service (DADS)	

Directory Assistance Database Service charge per listing	\$0.0193
Directory Assistance Database Service, per month	\$120.76
Direct Access to Directory Assistance (DADAS)	
Direct Access to Directory Assistance Service, per month	\$7,235.01
Direct Access to Directory Assistance Service, per query	\$0.0052
Direct Access to Directory Assistance Service, svc estab chg-NRC	\$1,186.94
NRC-Incremental Charge-Manual Service Order-1 st	NA
Direct Access to Directory Assistance Service, svc estab chg-NRC-Disconnect	NA
INTERIM SERVICE PROVIDER NUMBER PORTABILITY - RCF	
RCF, per number ported (Business Line), 10 paths	NA
RCF, per number ported (Residence Line), 6 paths	NA
RCF, per number ported (Business Line), each path	NA
RCF, per number ported (Residence Line), each path	NA
RCF, per number ported (Res or Bus Line)	NA
NRC	NA
NRC - Disconnect Chg	NA
RCF, add'l capacity for simultaneous call forwarding, per additional path	NA
RCF, per service order, per location - NRC - 1 st	NA
RCF, per service order, per location - NRC - Add'l	NA
RCF, per service order, per location - NRC - Disconnect - 1 st	NA
RCF, per service order, per location - NRC - Disconnect - Add'l	NA
Svc Provider No. Portability - Incremental Charge-Manual Svc Order	
NRC - 1 st	NA
NRC - Add'l	NA
NRC - Disconnect Chg - 1 st	NA
NRC - Disconnect Chg - Add'l	NA
INTERIM SERVICE PROVIDER NUMBER PORTABILITY - DID	
DID per number ported, Residence - NRC	NA
DID per number ported, Residence - NRC - Disconnect	NA
DID per number ported, Business - NRC	NA
DID per number ported, Business - NRC - Disconnect	NA
DID per service order, per location - NRC - 1 st	NA
DID per service order, per location - NRC - Add'l	NA
NRC-Incremental Charge-Manual Service Order	NA
DID per service order, per location - NRC - Disconnect - 1 st	NA
DID per service order, per location - NRC - Disconnect - Add'l	NA
DID, per trunk termination, Initial	NA
DID, per trunk termination, Initial - NRC	NA
DID, per trunk termination, Initial - Disconnect	NA
DID, per trunk termination, Subsequent	NA
DID, per trunk termination, Subsequent - NRC	NA
DID, per trunk termination, Subsequent - Disconnect	NA
Svc Provider No. Portability - Incremental Charge-Manual Svc Order	
NRC - 1 st	NA
NRC - Add'l	NA
NRC - Disconnect Chg - 1 st	NA
NRC - Disconnect Chg - Add'l	NA
ACCESS TO POLES, DUCTS, CONDUITS & RIGHTS OF WAY (8)	
Access to Poles, per pole, per foot, per year	NA
Access to Conduits, per foot, per year	NA
Access to Innerduct, per foot, per year	NA
AIN	

AIN Related Services with mediation, per query	NA
AIN, per message	NA
AIN - BellSouth AIN SMS Access Service	
AIN SMS Access Svc - Svc Estab per state, initial setup - NRC	NA
NRC-Incremental Charge-Manual Service Order	NA
AIN SMS Access Svc - Svc Estab per state, initial setup - NRC - Disconnect	NA
AIN SMS Access Svc - Port Connection-Dial/Shared Access - NRC	NA
NRC-Incremental Charge-Manual Service Order	NA
AIN SMS Access Svc - Port Connection-Dial/Shared Access - NRC-Disconnect	NA
AIN SMS Access Svc - Port Connection - ISDN Access - NRC	NA
NRC-Incremental Charge-Manual Service Order	NA
AIN SMS Access Svc - Port Connection - ISDN Access - NRC - Disconnect	NA
AIN SMS Access Svc - User ID Codes - per User ID Code - NRC	NA
NRC-Incremental Charge-Manual Service Order	NA
AIN SMS Access Svc - User ID Codes - per User ID Code - NRC - Disconnect	NA
AIN SMS Access Svc - Security Card per User ID Code, initial or replacement-NRC	NA
AIN SMS Access Svc - Security Card per User ID Code, initial or replacement-NRC - Disconnect	NA
NRC-Incremental Charge-Manual Service Order	NA
AIN SMS Access Service - Storage, per unit (100 Kb)	NA
AIN SMS Access Service - Session, per minute	NA
AIN SMS Access Service - Co. Performed Session, per minute	NA
AIN - BellSouth AIN Toolkit Service	
AIN, Service Creation Tools	NA
Service Establishment Charge, per state, initial setup - NRC	NA
NRC-Incremental Charge-Manual Service Order	NA
Service Establishment Charge, per state, initial setup - NRC - Disconnect	NA
Training Session, per customer - NRC	NA
NRC-Incremental Charge-Manual Service Order	NA
Trigger Access Charge, per trigger, per DN, Term. Attempt - NRC	NA
NRC-Incremental Charge-Manual Service Order	NA
Trigger Access Charge, per trigger, per DN, Term. Attempt - NRC - Disconnect	NA
Trigger Access Charge, per trigger per DN, Off-Hook Delay - NRC	NA
NRC-Incremental Charge-Manual Service Order	NA
Trigger Access Charge, per trigger per DN, Off-Hook Delay - NRC - Disconnect	NA
Trigger Access Charge, per trigger, per DN, Off-Hook Immediate - NRC	NA
NRC-Incremental Charge-Manual Service Order	NA
Trigger Access Charge, per trigger, per DN, Off-Hook Immediate - Disconnect	NA
Trigger Access Charge, per trigger, per DN, 10-Digit PODP - NRC	NA
NRC-Incremental Charge-Manual Service Order	NA
Trigger Access Charge, per trigger, per DN, 10-Digit PODP - Disconnect	NA
Trigger Access Charge, per trigger, per DN, CDP - NRC	NA
NRC-Incremental Charge-Manual Service Order	NA
Trigger Access Charge, per trigger, per DN, CDP - Disconnect	NA
Trigger Access Charge, per trigger, per DN, Feature Code - NRC	NA
NRC-Incremental Charge-Manual Service Order	NA
Trigger Access Charge, per trigger, per DN, Feature Code - Disconnect	NA
Query Charge, per query	NA
Type 1 Node Charge, per AIN Toolkit Subscription, per node, per query	NA
SCP Storage Charge, per SMS Access Acct, per 100 Kb	NA
Monthly report - per AIN Toolkit Service Subscription	NA
Monthly report - per AIN Toolkit Service Subscription - NRC	NA
NRC-Incremental Charge-Manual Service Order	NA

Monthly report - per AIN Toolkit Service Subscription - NRC - Disconnect	NA
Special Study - Per AIN Toolkit Service Subscription	NA
Special Study - Per AIN Toolkit Service Subscription - NRC	NA
NRC-Incremental Charge-Manual Service Order	NA
Call Event Report - per AIN Toolkit Service Subscription	NA
Call Event Report - per AIN Toolkit Service Subscription - NRC	NA
NRC-Incremental Charge-Manual Service Order	NA
Call Event Report - per AIN Toolkit Service Subscription - NRC - Disconnect	NA
Call Event special Study - per AIN Toolkit Service Subscription	NA
Call Event special Study - per AIN Toolkit Service Subscription - NRC	NA
NRC-Incremental Charge-Manual Service Order	NA
CALLING NAME (CNAM) QUERY SERVICE - DATABASE OWNER	
CNAM, Per Query	NA
DARK FIBER	
Per each four-fiber dry fiber arrangement, NRC 1 st	\$1,808.19
Per each four-fiber dry fiber arrangement, NRC Add'l	\$922.95
NRC - Incremental Charge--Manual Service Order—1 st	NA
NRC - Incremental Charge--Manual Service Order—Add'l	NA
Per each fiber strand per route mile or fraction thereof, per month	\$241.00
Per four fiber strands, per route mile or fraction thereof, per month	NA
Per four fiber strands per route foot or fraction thereof, per month	NA
SELECTIVE ROUTING	
Per Line or PBX Trunk, each	NA
Per Line or PBX Trunk, NRC	\$10.00 (Interim Rate)
Customized routing per unique line class code, per request, per switch	NA
NRC	NA

Notes:

N/A refers to rate elements which do not have a negotiated rate. Operational Support Systems (OSS) rates apply in all cases except for rate elements with specific OSS rates or specific incremental manual order charges.

- (1) In states where a specific NRC for customer transfer, feature additions and changes is not stated, the applicable NRC from the appropriate tariff applies.
- (2) Transmission/usage charges associated with POTS circuit switched usage will also apply to circuit switched voice and/or circuit switched data transmission by B-Channels associated with 2-wire ISDN ports.
- (3) Access to B Channel or D Channel Packet capabilities will be available only through Bona Fide Request/New Business Request Process. Rates for the packet capabilities will be determined via the Bona Fide Request/New Business Request Process.
- (4) This rate element is for those states which have a specific rate for User Profile per B Channel.
- (5) This rate element is for use in those states with a different rate for additional minutes of use.
- (6) This rate element is for those states w/o separate rates for 800 calls with 800 No. Delivery vs. POTS No. Delivery and calls with Optional Complex Features vs. w/o Optional Complex Features.
- (7) This charge is only applicable where signaling usage measurement or billing capability does not exist.
- (8) Rates for access to Poles, Ducts, Conduits and Rights-of-Way are negotiated with BellSouth's Competitive Structure Provisioning Center.

Amendment to Master Interconnection Agreement

by and between BellSouth Telecommunications, Inc.

and U S WEST Interprise America, Inc.

This Agreement refers to the Interconnection Agreement (“the Agreement”) entered into by U S WEST Interprise America, Inc. (“Interprise America”) and BellSouth Telecommunications, Inc. (“BellSouth”) on September 15, 1997 in the state of Kentucky. This Amendment (“Amendment”) is made by and between Interprise America and BellSouth and shall be deemed effective on the date executed by Interprise America and BellSouth.

NOW THEREFORE, in consideration of the mutual provisions contained herein and other good and valuable consideration, the receipt and sufficiency of which are hereby acknowledged, Interprise America and BellSouth (individually, a “Party” and collectively, the “Parties”) hereby covenant and agree as follows:

1. BellSouth and Interprise America are entering into this Agreement for the purpose of deleting Attachment 6, Connectivity and Billing, contained in their existing Agreement in its entirety and replacing it with the new Attachment 6, attached, for the purpose of removing the CRIS to CABS Billing Data Tape requirement.
2. The Parties agree that all other provisions of the Interconnection Agreement, dated September 15, 1997, shall remain in full force and effect.
3. The Parties further agree that either or both of the Parties is authorized to submit this Amendment to the Kentucky Public Service Commission or other regulatory body having jurisdiction over the subject matter of this Amendment, for approval subject to Section 252(e) of the federal Telecommunications Act of 1996.

IN WITNESS WHEREOF, the parties hereto have caused this Amendment to

be executed by their respective duly authorized representatives on the date indicated below.

U S WEST !nterprise America, Inc.

BellSouth Telecommunications, Inc.

Signature on file

Signature on file

Signature

Signature

Mary F. LaFave

Jerry D. Hendrix

Name

Name

Director Regulatory Affairs

Director - Interconnection Services

Title

Title

December 11, 1998

December 16, 1998

Date

Date

DUPLICATE ORIGINAL

TABLE OF CONTENTS

CONNECTIVITY BILLING AND RECORDING	1
1. GENERAL.....	1
2. BILLABLE INFORMATION AND CHARGES.....	1
3. MEET POINT BILLING	3
4. COLLOCATION.....	5
5. MUTUAL COMPENSATION.....	5
6. LOCAL NUMBER PORTABILITY	6
7. ISSUANCE OF BILLS - GENERAL	7
8. ELECTRONIC TRANSMISSIONS.....	8
9. TAPE OR PAPER TRANSMISSIONS	9
10. TESTING REQUIREMENTS	10
11. ADDITIONAL REQUIREMENTS	11
12. DELETED	12
13. PAYMENT OF CHARGES.....	12
14. BILLING DISPUTES.....	12
15. LATE PAYMENT CHARGES.....	13
16. ADJUSTMENTS	13
17. RECORDING OF CALL INFORMATION.....	14
18. DELETED	15

CONNECTIVITY BILLING AND RECORDING

1. **General**

This Section describes the requirements for BellSouth to bill and record all charges Interprise America incurs for purchasing Local Services for resale and for Network Elements and Combinations, and to provide Meet Point Billing and Mutual Compensation.

2. **Billable Information And Charges**

2.1 BellSouth will bill and record in accordance with this Agreement those charges Interprise America incurs as a result of Interprise America purchasing from BellSouth Network Elements, Combinations, and Local Services, as set forth in this Agreement. BellSouth will format all bills in Carrier Billing Output Specifications ("CBOS") Standard or CLUB/EDI format, depending on the type of service ordered. For those services where standards have not yet been developed, BellSouth's billing format will change as necessary when standards are finalized by the Industry forum. The Parties have agreed to specific elements of CLUB/EDI billing. Those elements are named in Exhibit A attached hereto and incorporated herein by this reference. Each bill shall set forth the quantity and description of each such Network Element, Combination, or Local Service provided and billed to Interprise America. All charges billed to Interprise America will indicate the state from which such charges were incurred except in cross boundary state situations. BellSouth shall provide Interprise America a listing of the current cross state boundary exchanges.

2.1.1 Interprise America and BellSouth will work together in a cooperative effort with the OBF to establish a single billing format and applicable standards. Once the billing standards/format are defined, BellSouth and Interprise America will mutually agree when the standards/format will be implemented.

2.2 BellSouth shall provide Interprise America a monthly bill that includes all charges incurred by and credits and/or adjustments due to Interprise America for those Network Elements, Combination thereof, or Local Services ordered, established, utilized, discontinued or performed pursuant to this Agreement. Each bill provided by BellSouth to Interprise America shall include: (1) all non-usage sensitive charges incurred for the period beginning with the day after the current bill date and extending to, and including, the next bill date; (2) any known unbilled non-usage sensitive charges for prior periods; (3) unbilled usage sensitive charges for the period beginning with the last bill date and extending through the current bill date; (4) any known unbilled usage sensitive charges for prior periods; and (5) any known unbilled adjustments.

With each resale bill, BellSouth will provide customer information sufficient for Interprise America to verify the charges. By line number, this information includes, but is not limited to: WTN, BTN, associated USOCs and service descriptions, quantities, charges and totals.

The Bill Date, as defined herein, must be present on each bill transmitted by BellSouth to Interprise America, must be a valid calendar date. Bills shall not be rendered for any charges which are incurred under this Agreement as described in 2.5 below. In addition, on each bill where "Jurisdiction" is identified, local and local toll charges shall be identified as "Local" and not as interstate, interstate/interLATA, intrastate, or intrastate/intraLATA. BellSouth will provide from and through dates for charges rendered on all bills. In addition, BellSouth will separately identify business charges from residence charges, as appropriate.

BellSouth shall not provide any connectivity bills to Interprise America containing charges for messages delivered any later than three billing periods following the recording date for all usage. In addition, all usage sent to Interprise America prior to the bill cut-off date, shall be included on the current month bill. In addition, for all other billed items, including network elements, combinations and non-usage resale charges, BellSouth shall endeavor to provide current billing but under no circumstances shall BellSouth provide any connectivity bill to Interprise America containing charges that were incurred more than six (6) months prior to the current bill date. Bill Certification standards and other performance standards (to be negotiated) will further decrease the allowable windows and provide "penalties" for windows that are met, so, these standards will change as mutually agreed upon by the Parties in writing.

- 2.6 BellSouth shall bill Interprise America for each Network Element, combination thereof, or Local Service, supplied by BellSouth to Interprise America pursuant to this Agreement at the rates set forth in this Agreement. BellSouth will bill Interprise America based on the actual charges incurred, provided, however, for those usage based charges where actual charge information is not determinable by BellSouth because the jurisdiction (i.e., interstate, interstate/interLATA, intrastate, intrastate/intraLATA, local) of the traffic is unidentifiable, the Parties will jointly develop a process to determine the appropriate charges. Measurement of usage-based charges shall be in actual conversation seconds. The total conversation seconds per chargeable traffic types will be totaled for the entire monthly bill cycle and then rounded to the next whole minute.
- 2.7 Each Party shall provide the other Party, at no additional charge, a contact person for the handling of any billing questions or problems that may arise during the implementation and performance of the terms and conditions of

this Attachment. Billing questions subsequent to implementation will be directed to the billing specialist in the Local Carrier Service Center (LCSC) for CRIS billing and through the Interexchange Carrier Service Center (ICSC) for CABS related issues.

3. Meet Point Billing

- 3.1 Where appropriate for unbundled network elements, Interprise America and BellSouth will establish meet-point billing ("MPB") arrangements in accordance with the Meet-Point Billing guidelines adopted by and contained in the OBF's MECAB and MECOD documents, except as modified herein. Both Parties will use their best reasonable efforts, individually and collectively, to maintain provisions in their respective federal and state access tariffs, and/or provisions within the National Exchange Carrier Association ("NECA") Tariff No. 4, or any successor tariff to reflect the MPB arrangements identified in this Agreement, in MECAB and in MECOD.
- 3.2 Interprise America and BellSouth will implement the Multiple Bill reflecting a single tariff option in which the Initial Billing Company (IBC) sends the usage to each Subsequent Billing Company (SBC). Each company then prepares and renders its own meet point bill in accordance with its tariff for its portion of the access services. Each company uses the usage provided by the IBC in order to bill any interexchange carrier ("IXC") for that portion of the network elements provided by Interprise America or BellSouth. For all traffic carried over the MPB arrangement, Interprise America and BellSouth shall bill each other all applicable elements at the rates specified in this Agreement.
- 3.3 BellSouth shall provide to Interprise America the billing name, billing address, and carrier identification code ("CIC") of the IXCs that may utilize any portion of Interprise America's network in a Interprise America/BellSouth MPB arrangement in order to comply with the MPB Notification process as outlined in the MECAB document. Such information shall be provided to Interprise America in the format and via the medium that the Parties agree. If BellSouth does not have a CIC for any IXC that will utilize a portion of Interprise America's network in an Interprise America/BellSouth MPB arrangement, and for whom BellSouth must supply to Interprise America MPB billing information, BellSouth agrees that it will assist such carrier in obtaining a CIC expeditiously. Until such carrier has obtained a CIC, BellSouth will submit BellSouth's CIC on those MPB records provided to Interprise America for MPB. BellSouth understands and agrees that it will be solely responsible for obtaining any reimbursements from those carriers who have utilized the jointly provided networks of BellSouth and Interprise America.
- 3.4 BellSouth and Interprise America agree that in an MPB arrangement where one Party provides local transport and the other Party provides the end office switching, the Party who provides the end office switching is entitled to bill any residual interconnection charges ("RIC") and common carrier line ("CCL")

- charges associated with the traffic. The Parties further agree that in those MPB situations where one Party sub-tends the other Party's access tandem, the Party providing the access tandem is only entitled to bill the access tandem fee and any associated local transport charges. The Parties also agree that the Party who provides the end office switching is entitled to bill end office switching fees, local transport charges, RIC and CCL charges, as appropriate, and such other applicable charges.
- 3.5 BellSouth and Interprise America will record and transmit MPB information in accordance with the standards and in the format set forth in this Attachment. BellSouth and Interprise America will coordinate and exchange the billing account reference ("BAR") and billing account cross reference ("BACR") numbers for the MPB arrangements described in this Agreement. Each Party will notify the other if the level of billing or other BAR/BACR elements change, resulting in a new BAR/BACR number.
- 3.6 If MPB data is not processed and delivered by either BellSouth or Interprise America and sent to the other Party within ten (10) days of their recording and in turn such Party is unable to bill the IXC for the appropriate charges, the Party who failed to deliver the data will be held liable for the amount of the unbillable charges. When the subsequent billing company ("SBC") is the recording company, they shall provide the initial billing company ("IBC") the detail billing records on a weekly basis (within five (5) days). If the IBC is the recording company, detail billing record exchange is not necessary. The IBC shall provide the SBC the summary billing records within ten (10) days from the IBC bill date. The Party who failed to deliver the data will be held liable for the amount of the unbillable charges.
- 3.7 If MPB data is not submitted within ten (10) days of their recording or is not in the proper format as set forth in this Agreement, and if as a result the other Party is delayed in billing the IXC for the appropriate charges it incurs, the delaying Party shall pay the other Party a late MPB data delivery charge which will be the total amount of the delayed charges times the highest interest rate (in decimal value) which may be levied by law for commercial transactions, compounded daily for the number of days from the date the MPB charges should have been received to and including the date the MPB charge information is actually received.
- 3.8 Errors in MPB data exchanged by the Parties may be discovered by Interprise America, BellSouth or the billable IXC. Both Interprise America and BellSouth agree to provide the other Party with notification of any discovered errors within two (2) business days of the discovery. The other Party shall correct the error within eight (8) business days of notification and resubmit the data. In the event the errors cannot be corrected within the time period specified above, the erroneous data may be considered lost. If MPB data is lost due to incorrecable errors or otherwise, the Parties shall follow the

procedures set forth in Attachment 7 Customer Usage Data Attachment of this Agreement and compensate the other for the lost MPB billing data.

- 3.9 In the event Interprise America purchases from BellSouth Network Elements, or Combination thereof, in a LATA other than the LATA to or from which the MPB services are homed and in which BellSouth operates an access tandem, BellSouth shall, except in instances of capacity limitations, permit and enable Interprise America to sub-tend the BellSouth access tandem switch(es) nearest to the Interprise America rating point(s) associated with the NPA-NXX(s) to/from which the MPB services are homed. In instances of capacity limitation at a given access tandem switch, Interprise America shall be allowed to sub-tend the next-nearest BellSouth access tandem switch in which sufficient capacity is available. The MPB percentages for each new rating point/access tandem pair shall be calculated in accordance with MECAB and MECOD.
- 3.10 Neither Interprise America nor BellSouth will charge the other for the services rendered, or for information provided pursuant to Section 4 of this Attachment except those MPB charges specifically set forth herein. Both Parties will provide the other a single point of contact to handle any MPB questions.

4. Collocation

When Interprise America collocates with BellSouth in BellSouth's facility as described in this Agreement, capital expenditures (e.g., costs associated with building the "cage"), shall not be included in the bill provided to Interprise America pursuant to this Attachment. All such capital expenses shall be given a unique BAN (as defined in Section 7, below) and invoice number. All invoices for capital expenses shall be sent to the location specified by Interprise America for payment. All other non-capital recurring collocation expenses shall be billed to Interprise America in accordance with this Agreement. The Carrier Billing Output Specifications ("BOS") documents provide the guidelines on how to bill the charges associated with collocation. The bill label for those collocation charges shall be entitled "Expanded Interconnection Service." For those nonmechanized bills, the bill label for non-capital recurring collocation expenses shall be entitled "Collocation".

5. Mutual Compensation

- 5.1 The Parties shall bill each other reciprocal compensation in accordance with the standards set forth in this Agreement for Local Traffic terminated to the other Party's customer. Such Local Traffic shall be recorded and transmitted to Interprise America and BellSouth in accordance with this Attachment. When a Interprise America Customer originates traffic and Interprise America sends it to BellSouth for termination, Interprise America will determine whether the traffic is local or toll. When a BellSouth Customer originates traffic and BellSouth sends it to Interprise America for termination, BellSouth

will determine whether the traffic is local or toll. Each Party will provide the other with information that will allow it to distinguish among local, intrastate toll and interstate toll traffic. At a minimum, each Party shall utilize NXXs in such a way that the other Party shall be able to distinguish local from intraLATA toll traffic. Where the originating Party cannot provide the terminating Party with actual usage data to enable the terminating Party to distinguish a local call from a toll call, the originating Party will report to the terminating Party its Percent Local Usage ("PLU") factors and the application of such PLUs will determine the amount of local minutes to be billed to the terminating Party. PLUs will be sent monthly or quarterly, as mutually agreed to by the Parties. Each Party may audit the traffic reported to it by the other Party as provided for in Section 11.2 of the General Terms and Conditions of this Agreement. When Interprise America interconnects with BellSouth's network for the purpose of completing local or toll traffic, Interprise America will, at its option, interconnect at either the tandem or end office switch to complete such calls paying local interconnection rates for its customers' local calls and switched access rates for its customers' toll calls. Such interconnection will be ordered as needed by Interprise America to complete such local and toll calls. Further, the Local Traffic exchanged pursuant to this Attachment shall be measured in billing minutes of use and shall be in actual conversation seconds. The total conversation seconds per chargeable traffic type will be totaled for the entire monthly billing cycle and then rounded to the next whole conversation minute. Reciprocal compensation for the termination of this Local Traffic shall be in accordance with Part IV to this Agreement. Except as provided in Section 11.2 of the General Terms and Conditions of this Agreement, each Party agrees not to charge the other Party for any costs incurred as a result of providing such Party with PLUs in lieu of sending actual usage data to distinguish local and toll traffic.

6. Local Number Portability

6.1 DELETED

6.2 When an IXC terminates an interLATA or IntraLATA toll call to a Interprise America local exchange customer whose telephone number has been ported from BellSouth, the Parties agree that Interprise America shall receive those IXC access charges associated with end office switching, local transport, RIC and CCL, as appropriate. BellSouth shall receive any access tandem fees, dedicated and common transport charges, to the extent provided by BellSouth, and any INP fees (i.e., such as RCF charges) set forth in this Agreement. When a call for which access charges are not applicable is terminated to a Interprise America local exchange customer whose telephone number has been ported from BellSouth, and is terminated on Interprise America's own switch, the Parties agree that the mutual compensation arrangements described in this Agreement shall apply.

7. Issuance of Bills - General

- 7.1 BellSouth and Interprise America will issue all bills in accordance with the terms and conditions set forth in this Section. BellSouth and Interprise America will establish monthly billing dates ("Bill Date") for each Billing Account Number ("BAN"), as further defined in the CABS document or CRIS elements set forth in Exhibit A as appropriate. On bills BellSouth renders to Interprise America, BANs shall be 13 character alpha/numeric and there shall only be one BAN per Revenue Accounting Office ("RAO") for each type of service rendered in a CLUB/EDI format. Separate BANs will be established for resale, CRIS charges associated with interim number portability, and Unbundled Network Elements. The Bill Date shall be the same day month to month for all BANs. On bills Interprise America renders to BellSouth, Interprise America will provide one (1) BAN per state and the bill date will be the same day month to month for all BANs. Each BAN shall remain constant from month to month, unless changed as agreed to by the Parties. Each Party shall provide the other Party at least thirty (30) calendar days written notice prior to changing, adding or deleting a BAN. The Parties will provide one billing invoice associated with each BAN. Each invoice must contain an invoice number (which will vary from month to month). The bill date is the only varying invoice number available on the Resale bill. On each bill associated with a BAN, the appropriate invoice number and the charges contained on such invoice must be reflected. All bills must be received by the other Party no later than ten (10) calendar days from Bill Date and at least twenty (20) calendar days prior to the payment due date (as described in this Attachment), whichever is earlier. Any bill received on a Saturday, Sunday or a day designated as a holiday by the Chase Manhattan Bank of New York (or such other bank as Interprise America shall specify) will be deemed received the next business day. If either Party fails to receive billing data and information within the time period specified above, the payment due date will be extended by the number of days the bill is late.
- 7.2 BellSouth and Interprise America shall issue all CABS bills in CABS format containing such billing data and information in accordance with CBOS Version 29, or such later versions of CABS as are published by BellCore, or its successor, except that if the Parties enter into a meet-point billing arrangement, such billing data and information shall also conform to the standards set forth in the MECAB document, or such later versions as are adopted by BellCore, or its successor. BellSouth shall be no more than one BOS version behind the currently accepted version for CABS formatted bills. To the extent that there are no CABS or MECAB standards governing the formatting of certain data, such data shall be issued in the format specified by Interprise America.

7.3 Within thirty (30) days of finalizing the chosen billing media, each Party will provide to the other Party written notice of which bills are to be deemed the official bills to assist the Parties in resolving any conflicts that may arise between the official bills and other bills received via a different media which purportedly contain the same charges as are on the official bill. Any billing received for a billing period pursuant to any media should contain identical information. To the extent that BellSouth is aware of a discrepancy in the billing media it sends to Interprise America, BellSouth shall notify Interprise America upon discovery of such discrepancy and at that time will designate which billing media shall be deemed to be the official bill. If either Party requests additional copy(ies) of a bill, such Party shall pay the other Party a reasonable fee per additional bill copy, unless such copy was requested due to loss or destruction due to causes beyond the requesting party's control, errors, omissions, or corrections or the failure of the transmission to comply with the specifications set forth in this Agreement.

7.4 When sending bills via electronic transmission, to avoid transmission failures or the receipt of billing information that cannot be processed, the Parties shall provide each other with their respective process specifications. Each Party shall comply with the mutually acceptable billing processing specifications of the other. Interprise America and BellSouth shall provide each other reasonable notice if a billing transmission is received that does not meet such Party's specifications or that such Party cannot process. Such transmission shall be corrected and resubmitted to the other Party, at the resubmitting Party's sole expense, in a form that can be processed. The payment due date for such resubmitted transmissions will be twenty (20) days from the date that the transmission is received in a form that can be processed and that meets the specifications set forth in this Attachment.

8. **Electronic Transmissions**

8.1 BellSouth and Interprise America agree that each Party will transmit billing information and data in the appropriate Industry Standard format electronically via CONNECT:Direct (formerly known as Network Data Mover) to the other Party at the location specified by such Party. The Parties agree that a T1.5 or 56kb circuit to Gateway for CONNECT:Direct is required. If BellSouth has an established CONNECT:Direct link with Interprise America, that link can be used for data transmission if the location and applications are the same for the existing link. Otherwise, a new link for data transmission must be established. Any changes to either Party's CONNECT:Direct Node ID must be sent to the other Party no later than twenty-one (21) calendar days before the changes take effect. Parties agree to exchange information necessary to establish CONNECT:Direct.

8.2 **DELETED**

9. Tape or Paper Transmissions

9.1 In the event either Party does not temporarily have the ability to send or receive data via CONNECT:Direct, that Party will transmit billing information to the other party via magnetic tape or paper, as appropriate and as agreed to by Interprise America and BellSouth.. Billing information and data contained on magnetic tapes or paper for payment shall be sent to the Parties at the following locations. The Parties acknowledge that all tapes transmitted to the other Party via U.S. Mail or Overnight Delivery and which contain billing data will not be returned to the sending Party.

TO Interprise America:

Tape : Resale Bill Transmissions via Overnight Delivery:	Interprise America National Expansion Accounts Payable Attn: Billing Manager 1999 Broadway, 7 th Floor Denver, CO 80202
Tape : UNE Bills Transmissions via Overnight Delivery:	Interprise America National Expansion Accounts Payable Attn: Billing Manager 1999 Broadway, 7 th Floor Denver, CO 80202

Paper:Resale Bill Transmissions via Overnight Delivery:	Interprise America National Expansion Accounts Payable Attn: Billing Manager 1999 Broadway, 7 th Floor Denver, CO 80202
Paper:UNE Bills Transmissions via Overnight Delivery:	Interprise America National Expansion Accounts Payable Attn: Billing Manager 1999 Broadway, 7 th Floor Denver, CO 80202

TO BellSouth:

Tape Transmissions:	Attn:
Paper Transmissions:	Attn:

9.2 Each Party will adhere to the tape packaging requirements set forth in this subsection. Where magnetic tape shipping containers are transported in freight compartments, adequate magnetic field protection shall be provided by keeping a typical 6-inch distance from any magnetic field generating device (except a magnetron-tape device). The Parties agree that they will only use those shipping containers that contain internal insulation to prevent damage. Each Party will clearly mark on the outside of each shipping container its name, contact and return address. Each Party further agrees that it will not ship any Connectivity Billing tapes in tape canisters.

9.3 All billing data transmitted via tape must be provided on a cartridge (cassette) tape and must be of high quality, conform to the Parties' record and label standards, 9-track, odd parity, 6250 BPI, group coded recording mode and extended binary-coded decimal interchange code ("EBCDIC"). Each reel of tape must be 100% tested at 20% or better "clipping" level with full width certification and permanent error free at final inspection. Interprise America reserves the right to destroy a tape that has been determined to have unrecoverable errors. Interprise America also reserves the right to replace a tape with one of equal or better quality.

9.4 All electronic data will conform to CBOS/EDI published standards.

10. **Testing Requirements**

10.1 Within thirty (30) days of the execution of this Agreement, BellSouth shall send to Interprise America bill data in the appropriate mechanized format (i.e. CBOS or EDI) for testing to ensure that bills can be processed and that bills comply with the requirements of this Attachment 6. After receipt of the test data from BellSouth, Interprise America will notify BellSouth if the billing transmission meets standard specifications. If the transmission fails to meet standard specifications, BellSouth shall make the necessary corrections. At least three (3) sets of testing data must meet standard specifications prior to

Interprise America - KY
12/8/98

BellSouth sending Interprise America a mechanized production bill for the first time via electronic transmission or tape. Thereafter, BellSouth may begin sending Interprise America mechanized production bills on the next Bill Date, or within ten (10) days, whichever is later.

- 10.2 At least thirty (30) days prior to changing mechanized formats (e.g., CBOS Changes), BellSouth shall send to Interprise America bill data in the appropriate mechanized format for testing to ensure that the bills can be processed and that the bills comply with the requirements of this Attachment. BellSouth agrees that it will not send Interprise America bill data in the new mechanized format until such bill data has met the testing specifications as set forth in this subsection. Notification of changes shall be in accordance with Section 24.3.2.3 of the General Terms and Conditions of this Agreement.
- 10.3 BellSouth shall provide to Interprise America's Billing Manager, located at 1999 Broadway, 7th floor, Denver, CO 80202, BellSouth's originating or state level company code so that it may be added to Interprise America's internal tables at least thirty (30) calendar days prior to testing or prior to a change in BellSouth's originating or state level company code.
- 10.4 During the testing period, BellSouth shall transmit to Interprise America billing data and information via paper transmission. Test tapes shall be sent to Interprise America at the same locations as "production" or live files.

Test Tapes:	Interprise America National Expansion Accounts Payable Attn: Billing Manager 1999 Broadway, 7 th Floor Denver, CO 80202
-------------	---

11. Additional Requirements

- 11.1 BellSouth agrees that if it transmits data to Interprise America in a mechanized format, BellSouth will also comply with the following specifications which are not contained in CBOS guidelines but which are necessary for Interprise America to process billing information and data:
- The BAN shall not contain embedded spaces or low values.
 - The Bill Date shall not contain spaces or non-numeric values.
 - Any "From" Date should be less than the associated "Thru" Date and neither date can contain spaces.

11.2 DELETED

12. **DELETED**

13. **Payment Of Charges**

13.1 Subject to the terms of this Agreement, Interprise America and BellSouth will pay each other within thirty (30) calendar days from the Bill Date, or twenty (20) calendar days from the receipt of the bill, whichever is later. If the payment due date is a Sunday or is a Monday that has been designated a bank holiday by the Chase Manhattan Bank of New York (or such other bank as Interprise America specifies), payment will be made the next business day. If the payment due date is a Saturday or is on a Tuesday, Wednesday, Thursday or Friday that has been designated a bank holiday by the Chase Manhattan Bank of New York (or such other bank as Interprise America specifies), payment will be made on the preceding business day.

13.2 Payments shall be made in U.S. Dollars via electronic funds transfer ("EFT") and/or Automated Clearinghouse ("ACH") to the other Party's bank account. At least thirty (30) days prior to the first transmission of billing data and information for payment, BellSouth and Interprise America shall provide each other the name and address of its bank, its account and routing number and to whom billing payments should be made payable. If such banking information changes, each Party shall provide the other Party at least sixty (60) days written notice of the change and such notice shall include the new banking information. The Parties will render payment via EFT and/or ACH. Interprise America will provide BellSouth with one address to which such payments shall be rendered and BellSouth will provide to Interprise America with only one address to which such payments shall be rendered. In the event Interprise America receives multiple bills from BellSouth which are payable on the same date, Interprise America may remit one payment for the sum of all bills payable to BellSouth's bank account specified in this subsection. Each Party shall provide the other Party with a contact person for the handling of billing payment questions or problems.

14. **Billing Disputes**

14.1 Each Party agrees to notify the other Party upon the discovery of a billing dispute. In the event of a billing dispute, the Parties will endeavor to resolve the dispute within sixty (60) calendar days of the Bill Date on which such disputed charges appear. Resolution of the dispute is expected to occur at the first level of management resulting in a recommendation for settlement of the dispute. In the event of a billing dispute that cannot be resolved within the 60-day timeframe, the process described in Exhibit B to this Attachment shall be followed.

14.2 If a Party disputes a charge and does not pay such charge by the payment due date, such charges shall be subject to late payment charges as set forth in the Late Payment Charges provision of this Attachment. If a Party disputes

charges and the dispute is resolved in favor of such Party, the other Party shall credit the bill of the disputing Party for the amount of the disputed charges along with any late payment charges assessed no later than the second Bill Date after the resolution of the dispute. Accordingly, if a Party disputes charges and the dispute is resolved in favor of the other Party, the disputing Party shall pay the other Party the amount of the disputed charges and any associated late payment charges assessed no later than the second bill payment due date after the resolution of the dispute. In no event, however, shall any late payment charges be assessed on any previously assessed late payment charges.

14.2.1 If billing is determined to be in error and Interprise America has paid the bill in full and on time, BellSouth will refund the amount of the erroneous billing plus any interest penalty credit to be calculated as set forth in Section 15 of this Attachment.

15. **Late Payment Charges**

If either Party fails to remit payment for any charges described in this Attachment by the payment due date, or if a payment or any portion of a payment is received by either Party after the payment due date, or if a payment or any portion of a payment is received in funds which are not immediately available to the other Party, then a late payment penalty shall be assessed. For bills rendered by BellSouth for payment by Interprise America, the late payment charge shall be calculated based on the portion of the payment not received by the payment due date times the late factor set forth in the following: BellSouth tariffs, based upon the service for which payment was not received: for general subscriber services, Section A2 of the General Subscriber Services Tariff; for private line service, Section B2 of the Private Line Service Tariff; and for access service, Section E2 of the Access Service Tariff. For bills rendered by Interprise America for payment by BellSouth the late payment charge shall be calculated based on the portion of the payment not received by the payment date times the lessor of (i) one and one-half percent (1½%) per month or (ii) the highest interest rate (in decimal value) which may be charged by law for commercial transactions, compounded daily for the number of days from the payment date to and including the date that payment is actually made. BellSouth shall only assess interest on previously assessed late payment charges in a state where it has the authority pursuant to its tariff.

16. **Adjustments**

Subject to the terms of this Attachment, BellSouth will reimburse Interprise America for incorrect billing charges; overcharges; Local Services Elements, or any Combination thereof, ordered or requested but not delivered; interrupted Local Services associated with any Element, or combination thereof, ordered or requested; Local Services, Elements, or Combination

thereof, of poor quality; and installation problems if caused by BellSouth. Such reimbursements shall be set forth in the appropriate section of the bill pursuant to applicable standards.

17. Recording of Call Information

17.1 Where Telecommunications Services are being resold or unbundled Network Elements are being utilized, the Parties agree to record call information in accordance with this subsection. To the extent technically feasible, each Party will record and process the usage sensitive call detail information associated with the other Party's local exchange customer. The call records for the charged number shall be provided at a Party's request and shall be formatted pursuant to BellCore standards and the terms and conditions of this Agreement. BellSouth and Interprise America agree that they will retain, at each Party's sole expense, copies of all AMA transmitted to the other Party for at least seven (7) calendar days after transmission to the other Party.

17.2 Each Party will provide the other Party with a carrier identification code ("CIC") on each EMR record transmitted to the other Party. If BellSouth does not have a CIC for any local exchange carrier, BellSouth or IXC for whom BellSouth must supply to Interprise America billing records or information pursuant to this Attachment, BellSouth agrees that it will assist the local exchange carrier, BellSouth or IC in obtaining a CIC expeditiously. Until the local exchange carrier, BellSouth or IXC has received a CIC, BellSouth agrees that it will submit its CIC to Interprise America on those records for billing and payment. BellSouth further agrees that it will then be responsible for obtaining reimbursement for the respective charges from the appropriate carrier. Likewise, if Interprise America does not have a CIC for any local exchange carrier, BellSouth or IXC for whom Interprise America must supply to BellSouth billing records or information pursuant to this Attachment, Interprise America agrees that it will assist the local exchange carrier, BellSouth or IXC in obtaining a CIC expeditiously. Until the local exchange carrier, BellSouth or IXC has received a CIC, Interprise America agrees that it will submit its CIC to BellSouth on those records for billing and payment. Interprise America further agrees that it will then be responsible for obtaining reimbursement for the respective charges from the appropriate carrier.

17.3 **DELETED**

17.3.1 **DELETED**

17.3.2 **DELETED**

17.3.3 **DELETED**

17.4 The Parties agree that they will provide each other a single person to contact regarding any data exchange problems.

18. **DELETED**

19. **Claims/Adjustments Appearance on Invoice**

19.1 Resolved claims or disputes would be reflected separately and detailed by item with Interprise America's claim memo number on the invoice and be included as an amount credited on the monthly invoice. Claims or disputes still outstanding would also be included on the monthly bill.

19.2 No Netting of Amounts Due/Separation of Types of Billing

The Parties agree that there shall be no netting of amounts due BellSouth under this agreement with any other amounts due to or from BellSouth related to services provided under separate agreements. Further Resale bills, Access bills and UNE bills will be provided as separate bills with separate amounts due that shall not be netted.

**REQUIREMENTS FOR CLUB/EDI BILLING
OF
Interprise America LOCAL SERVICES**

Interprise America and BellSouth agree to the following requirements for CLUB/EDI billing for Local Service Resale:

- BellSouth will provide a 13 character alpha-numeric Billing Account Number (BAN)
- BellSouth will provide one (1) BAN per Regional Accounting Office (RAO) for each type of service billed
- BellSouth will provide one (1) bill cycle for all BANs / RAOs excluding the 4th, 7th and 13th bill cycles
- BellSouth will render the bill within ten (10) days of the bill date
- Interprise America will render payment 30 days from the bill date or 20 days from the date the bill is received, whichever is greater
- Interprise America will render payment via wire transfer and/or ACH to the existing billing address
- BellSouth will render billing for PIC charges separately
- BellSouth will bill monthly service charges in advance of the bill date
- BellSouth will bill usage charges in arrears of the bill date
- BellSouth will identify all charges by incurred state except in cross boundary situations
- BellSouth will uniquely identify the local billing BANs as Type Of Account 'Q'
- BellSouth will separately identify business and residence charges
- BellSouth will provide From and Through dates for all local billing

**BELLSOUTH LOCAL CARRIER SERVICE CENTER (LCSC)
ESCALATION LIST**

LOCAL CARRIER SERVICE CENTER

Telephone Numbers Office800-872-3116
Local Service Requests, LSR Questions,
Billing Inquiries and General Assistance

Fax Number800-872-7059
All Forms

Managers Director
Barbara Warren700-451-0853

Manager
Paula Murphry700-451-0883

Mailing Address Local Carrier Service Center (LCSC)
BellSouth
Room D-20
5147 Peachtree Industrial Boulevard
Chamblee, GA 30341

Hours of Operation 8:30 AM to 5:00 PM EST
Monday - Friday

Holidays Observed New Years Day
Memorial Day
Independence Day
Labor Day
Thanksgiving Day
Christmas Day

Process Interprise America will escalate any billing discrepancies to the BellSouth LCSC Manager. If resolution is not attained within 30 days, Interprise America will escalate the discrepancy to the BellSouth Director. If the billing discrepancy is not resolved within 30 days, Interprise America will obtain the name and number of the next level manager from the BellSouth Director and continue escalating until a resolution is reached.

**Amendment to Master Interconnection Agreement
by and between BellSouth Telecommunications, Inc.
and U S West Interprise America - Kentucky**

Pursuant to this Agreement, (the "Amendment"), U S West Interprise America, Inc. ("Interprise America"), and BellSouth Telecommunications, Inc. ("BellSouth"), hereinafter referred to collectively as the "Parties," hereby agree to amend that certain Interconnection Agreement ("Agreement") between the Parties dated September 15, 1997.

WHEREAS, BellSouth and Interprise America entered into an Interconnection Agreement for the state of Kentucky on September 15, 1997, and;

NOW THEREFORE, in consideration of the mutual provisions contained herein and other good and valuable consideration, the receipt and sufficiency of which are hereby acknowledged, the Parties hereby covenant and agree as follows:

1. The Agreement entered into between BellSouth and Interprise America, is hereby amended to delete Attachment 3 Section 2 in its entirety and replace it with a new Attachment 3 Section 2 which incorporates herein as Exhibit 1, the rules set forth by the FCC in its Decision 99-48, Docket No. 98-147 following.

2. All of the other provisions of the Agreement, dated September 15, 1997, shall remain in full force and effect.

3. Either or both of the Parties is authorized to submit this Amendment to the Kentucky Public Service Commission for approval subject to Section 252(e) of the Federal Telecommunications Act of 1996.

IN WITNESS WHEREOF, the Parties hereto have caused this Amendment to be executed by their respective duly authorized representatives on the date indicated below.

U S West Interprise America

BellSouth Telecommunications, Inc.

Signature on File
Signature

Signature on File
Signature

Mary F. LaFave
Name

Jerry D. Hendrix
Name

Director – Regulatory Affairs
Title

Senior Director
Title

September 8, 1999
Date

September 21, 1999
Date

DUPLICATE ORIGINAL

**Amendment to Master Interconnection Agreement
by and between BellSouth Telecommunications, Inc.
and U S West Interprise America - Kentucky**

Exhibit 1

Attachment 3 Section 2

Physical Collocation

BELLSOUTH PHYSICAL COLLOCATION

The rates, terms and conditions contained within this Attachment were negotiated as a whole and each rate, term and condition within the Attachment is interdependent upon the other rates, terms and conditions.

1. SCOPE OF ATTACHMENT

1.1 Scope of Attachment. The rates, terms, and conditions contained within this Attachment shall only apply when Interprise America is occupying the collocation space as a sole occupant or as a Host pursuant to Section 4.

1.2 Right to occupy. Subject to Section 4 of this Attachment, BellSouth hereby grants to Interprise America a right to occupy that certain area designated by BellSouth within a BellSouth central office premises, of a size which is specified by Interprise America and agreed to by BellSouth (hereinafter "Collocation Space"). Notwithstanding the foregoing, BellSouth shall consider in its designation for cageless collocation any unused space within the BellSouth central office premises. The size specified by Interprise America may contemplate a request for space sufficient to accommodate Interprise America's growth within a two year period unless otherwise agreed to by the Parties.

1.2.1 Space Reclamation. In the event of space exhaust within a central office premises, Interprise America may be required to release space to BellSouth to be allocated to other physical collocation applicants when a minimum of fifty percent of the total amount of space in Interprise America's collocation arrangement is not being utilized within the first year of operation, or 100% of the total amount of space by the end of the second year of operation.

1.3 Use of Space. Interprise America shall use the Collocation Space for the purposes of installing, maintaining and operating Interprise America's equipment (to include testing and monitoring equipment) used or useful primarily to interconnect with BellSouth services and facilities, including access to unbundled network elements, for the provision of telecommunications services. Pursuant to Section 5 following, Interprise America may at its option, place Interprise America-owned fiber entrance facilities to the Collocation Space. In addition to, and not in lieu of, interconnection to BellSouth services and facilities, Interprise America may connect to other interconnectors within the designated BellSouth Central Office (including to its other virtual or physical collocated arrangements) through co-carrier cross connect facilities designated by Interprise America pursuant to section 5.6 following. The Collocation Space may be used for no other purposes except as specifically described herein or authorized in writing by BellSouth.

1.4 Rates and charges. Interprise America agrees to pay the rates and charges identified at Exhibit A attached hereto.

2. SPACE NOTIFICATION

2.1 Availability of Space. Upon submission of an application pursuant to Section 6, BellSouth will permit Interprise America to physically collocate, pursuant to the terms of this Attachment, at any BellSouth central office premises, unless BellSouth has determined that there is no space available due to space limitations or no space available due to technical infeasibility. BellSouth will respond to an application within ten (10) business days as to whether space is available or not available within a BellSouth central office premises.

2.2 Reporting. Upon request from Interprise America, BellSouth will provide a written report specifying the amount of collocation space available at the central office premises requested, the number of collocators present at the central office premises, any modifications in the use of the space since the last report or the central office premises requested and the measures BellSouth is taking to make additional space available for collocation arrangements.

2.2.1 The request from Interprise America must be written and must include the central office premises and Common Language Location Identification (CLLI) code of the central office premises. Such information regarding central office premises and CLLI code is located in the National Exchange Carriers Association (NECA) Tariff FCC No. 4.

2.2.2 BellSouth will respond to a request for a particular Central Office location within ten (10) business days of receipt of such request. BellSouth will make best efforts to respond in ten (10) business days to such a request when the request includes up to and including five (5) Central Office locations within the same state. The response time for requests of more than five (5) shall be negotiated between the Parties. If BellSouth cannot meet the ten business day response time, BellSouth shall notify Interprise America and inform Interprise America of the time frame under which it can respond.

2.3 Denial of Application. After notifying Interprise America that BellSouth has no available space in the requested Central Office ("Denial of Application"), BellSouth will allow Interprise America, upon request, to tour the entire Central Office within ten (10) business days of such Denial of Application. In order to schedule said tour within ten (10) business days, the request for a tour of the Central Office must be received by BellSouth within five (5) business days of the Denial of Application.

2.4 Filing of Petition for Waiver. Upon Denial of Application BellSouth will timely file a petition with the Commission pursuant to 47 U.S.C. § 251(c)(6).

2.5 Waiting List. On a first come first served basis, BellSouth will maintain a waiting list of requesting carriers who have either received a Denial of Application or, where it is publicly known that the central office premises is out of space, have submitted a Letter of Intent to collocate. BellSouth will notify the telecommunications carriers on the waiting list when space becomes available according to how much space becomes available and the position of telecommunications carrier on said waiting list. Upon request BellSouth will advise Interprise America as to its position on the list.

2.6 Public Notification. BellSouth will maintain on its Interconnection Services website a notification document that will indicate all central office premises that are without available space. BellSouth shall update such document within ten (10) business days of the Denial of Application date. BellSouth will also post a document on its Interconnection Services

website that contains a general notice where space has become available in a Central Office previously on the space exhaust list. BellSouth shall allocate said available space pursuant to the waiting list referenced in Section 2.5.

2.7 State Agency Procedures. Notwithstanding the foregoing, should any state regulatory agency impose a procedure different than procedures set forth in this section, that procedure shall supersede the requirements set forth herein.

3. COLLOCATION OPTIONS

- 3.1 Cageless. Except where local building code does not allow cageless collocation, BellSouth shall allow Interprise America to collocate Interprise America's equipment and facilities without requiring the construction of a cage or similar structure and without requiring the creation of a separate entrance to the Collocation Space. BellSouth shall allow Interprise America to have direct access to its equipment and facilities but may require Interprise America to use a central entrance to the BellSouth Central Office. BellSouth shall make cageless collocation available in single bay increments pursuant to Section 7. Except where Interprise America's equipment requires special technical considerations (e.g., special cable racking, isolated ground plane), BellSouth shall assign cageless Collocation Space in conventional equipment rack lineups where feasible. For equipment requiring special technical considerations, Interprise America must provide the equipment layout, including spatial dimensions for such equipment pursuant to generic requirements contained in BellCore (Telcordia) GR-63-Core and shall be responsible for constructing all special technical requirements associated with such equipment pursuant to Section 6.5 following.
- 3.2 Cages and Adjacent Arrangement Enclosures. BellSouth shall authorize the enclosure of Interprise America's equipment and facilities at Interprise America's option or if required by local building code. Interprise America must arrange with a BellSouth certified contractor to construct a collocation arrangement enclosure in accordance with BellSouth's guidelines and specifications and at its sole expense. BellSouth will provide guidelines and specifications upon request. Where local building codes require enclosure specifications more stringent than BellSouth's standard enclosure specification, Interprise America and Interprise America's BellSouth certified contractor must comply with local building code requirements. Interprise America's BellSouth certified contractor shall be responsible for filing and receiving any and all necessary permits and/or licenses for such construction. The Certified Vendor shall bill Interprise America directly for all work performed for Interprise America pursuant to this Attachment and BellSouth shall have no liability for nor responsibility to pay such charges imposed by the Certified Vendor. Interprise America must provide the local BellSouth building_contact with two Access Keys used to enter the locked enclosure. Except in case of emergency, BellSouth will not access Interprise America's locked enclosure prior to notifying Interprise America.

3.2.1 BellSouth has the right to review Interprise America's plans and specifications prior to allowing construction to start. BellSouth has the right to inspect the enclosure after construction to make sure it is designed and constructed according to BellSouth's guidelines and specifications and to require Interprise America to remove or correct at Interprise America's cost any structure that does not meet these standards.

3.3 Shared (Subleased) Caged Collocation. Interprise America may allow other telecommunications carriers to share Interprise America's caged collocation arrangement pursuant to terms and conditions agreed to by Interprise America ("Host") and other telecommunications carriers ("Guests") and pursuant to this section with the following exceptions: (1) where local building code does not allow Shared (Subleased) Caged Collocation and (2) where the BellSouth central office premises is located within a leased space and BellSouth is prohibited by said lease from offering such an option. The terms and conditions of the agreement between the Host and its Guests shall be written and a copy provided to the BellSouth contact specified in Section 15 within ten (10) business days of its execution and prior to any Firm Order. Further, said agreement shall incorporate by reference the rates, terms, and conditions of this Attachment between BellSouth and Interprise America.

3.3.1 Interprise America shall be the sole interface and responsible party to BellSouth for the purpose of submitting applications for initial and additional equipment placements of Guest; for assessment of rates and charges contained within this Attachment; and for the purposes of ensuring that the safety and security requirements of this Attachment are fully complied with by the Guest, its employees and agents. The initial Guest application shall require the assessment of an Application Fee, as set forth in Exhibit A. Notwithstanding the foregoing, Guest may arrange directly with BellSouth for the provision of the interconnecting facilities between BellSouth and Guest and for the provisions of the services and access to unbundled network elements.

3.3.2 Interprise America shall indemnify and hold harmless BellSouth from any and all claims, actions, causes of action, of whatever kind or nature arising out of the presence of Interprise America's Guests in the Collocation Space.

3.4 Adjacent Collocation. BellSouth will provide adjacent collocation arrangements ("Adjacent Arrangement") where space within the Central Office is legitimately exhausted, subject to technical feasibility, where the Adjacent Arrangement does not interfere with access to existing or planned structures or facilities on the Central Office property and where permitted by zoning and other applicable state and local regulations. The Adjacent Arrangement shall be constructed or procured by Interprise America and in conformance with BellSouth's design and construction specifications. Further, Interprise America shall construct, procure, maintain and operate said Adjacent Arrangement(s) pursuant to all of the terms and conditions set forth in this Attachment. Rates shall be negotiated at the time of the request for Adjacent Collocation.

3.4.1 Should Interprise America elect such option, Interprise America must arrange with a BellSouth certified contractor to construct an Adjacent Arrangement structure in accordance with BellSouth's guidelines and specifications. BellSouth will provide guidelines and specifications upon request. Where local building codes require enclosure specifications more stringent than BellSouth's standard specification, Interprise America and Interprise America's contractor must comply with local building code requirements. Interprise America's contractor shall be responsible for filing and receiving any and all necessary zoning, permits and/or licenses for such construction. Interprise America's BellSouth Certified Vendor shall bill Interprise America directly for all work performed for Interprise America pursuant to this Attachment and BellSouth shall have no liability for nor responsibility to pay such charges imposed by the Certified Vendor. Interprise America must provide the local BellSouth building contact with two cards, keys or other access device used to enter the locked enclosure. Except in cases of emergency, BellSouth shall not access Interprise America's locked enclosure prior to notifying Interprise America.

3.4.2 BellSouth maintains the right to review Interprise America's plans and specifications prior to construction of an Adjacent Arrangement(s). BellSouth may inspect the Adjacent Arrangement(s) following construction and prior to commencement, as defined in Section 4.1 following, to ensure the design and construction comply with BellSouth's guidelines and specifications. BellSouth may require Interprise America, at Interprise America's sole cost, to correct any deviations from BellSouth's guidelines and specifications found during such inspection(s), up to and including removal of the Adjacent Arrangement, within five (5) business days of BellSouth's inspection, unless the Parties mutually agree to an alternative time frame.

3.4.3 Interprise America shall provide a concrete pad, the structure housing the arrangement, HVAC, lighting, and all facilities that connect the structure (i.e. racking, conduits, etc.) to the BellSouth point of interconnection. At Interprise America's option, BellSouth shall provide an AC power source and access to physical collocation services and facilities subject to the same nondiscriminatory requirements as applicable to any other physical collocation arrangement.

3.4.4 BellSouth shall allow Shared (Subleased) Caged Collocation within an Adjacent Arrangement pursuant to the terms and conditions set forth in Section 3.3 proceeding.

4. OCCUPANCY

4.1 Commencement Date. The "Commencement Date" shall be the day Interprise America's equipment becomes operational as described in Article 4.2, following.

4.2 Occupancy. BellSouth will notify Interprise America in writing that the Collocation Space is ready for occupancy. Interprise America must place operational telecommunications equipment in the Collocation Space and connect with BellSouth's network within one hundred eighty (180) days after receipt of such notice. Interprise America must notify BellSouth in writing that collocation equipment installation is complete and is operational with BellSouth's network. BellSouth may, at its option, not accept orders for interconnected service until receipt of such notice. If Interprise America fails to place operational telecommunications equipment in the Collocation Space within 180 calendar days and such failure continues for a period of thirty (30) days after receipt of written notice from BellSouth, then and in that event Interprise America's

right to occupy the Collocation Space terminates and BellSouth shall have no further obligations to Interprise America with respect to said Collocation Space. Termination of Interprise America's rights to the Collocation Space pursuant to this paragraph shall not operate to release Interprise America from its obligation to reimburse BellSouth for all costs reasonably incurred by BellSouth in preparing the Collocation Space, but rather such obligation shall survive this Attachment. For purposes of this paragraph, Interprise America's telecommunications equipment will be deemed operational when cross-connected to BellSouth's network for the purpose of service provision.

4.3 Termination. Except where otherwise agreed to by the Parties, Interprise America may terminate occupancy in a particular Collocation Space upon thirty (30) days prior written notice to BellSouth. Upon termination of such occupancy, Interprise America at its expense shall remove its equipment and other property from the Collocation Space. Interprise America shall have thirty (30) days from the termination date to complete such removal, including the removal of all equipment and facilities of Interprise America's Guests; provided, however, that Interprise America shall continue payment of monthly fees to BellSouth until such date as Interprise America has fully vacated the Collocation Space. Should Interprise America fail to vacate the Collocation Space within thirty (30) days from the termination date, BellSouth shall have the right to remove the equipment and other property of Interprise America at Interprise America's expense and with no liability for damage or injury to Interprise America's property unless caused by the gross negligence or intentional misconduct of BellSouth. Upon expiration of this Attachment, Interprise America shall surrender the Collocation Space to BellSouth in the same condition as when first occupied by the Interprise America except for ordinary wear and tear. Interprise America shall be responsible for the cost of removing any enclosure, together with all support structures (e.g., racking, conduits), of an Adjacent Collocation arrangement at the termination of occupancy and restoring the grounds to their original condition.

5. USE OF COLLOCATION SPACE

5.1 Equipment Type. BellSouth permits the collocation of any type of equipment used or useful for interconnection to BellSouth's network or for access to unbundled network elements in the provision of telecommunications services. Such equipment used or useful for interconnection and access to unbundled network elements includes, but is not limited to transmission equipment including, but not limited to, optical terminating equipment and multiplexers, and digital subscriber line access multiplexers, routers, asynchronous transfer mode multiplexers, and remote switching modules. Nothing in this section requires BellSouth to permit collocation of equipment used solely to provide enhanced services; provided, however, that BellSouth may not place any limitations on the ability of requesting carriers to use all the features, functions, and capabilities of equipment collocated pursuant to this section.

5.1.1 Such equipment must at a minimum meet the following BellCore (Telcordia) Network Equipment Building Systems (NEBS) General Equipment Requirements: Criteria Level 1 requirements as outlined in the BellCore (Telcordia) Special Report SR-3580, Issue 1; equipment design spatial requirements per GR-63-CORE, Section 2; thermal heat dissipation per GR-063-CORE, Section 4, Criteria 77-79; acoustic noise per GR-063-CORE, Section 4, Criterion 128, and National Electric Code standards.

5.1.2 Interprise America shall not use the Collocation Space for marketing purposes nor shall it place any identifying signs or markings in the area surrounding the Collocation Space or on the grounds of the central office premises.

5.1.3 Interprise America shall place a plaque or other identification affixed to Interprise America's equipment necessary to identify Interprise America's equipment, including a list of emergency contacts with telephone numbers.

5.2 Entrance Facilities. Interprise America may elect to place Interprise America-owned or Interprise America-leased fiber entrance facilities into the Collocation Space. BellSouth will designate the point of interconnection in close proximity to the Central Office building housing the Collocation Space, such as an entrance manhole or a cable vault which are physically accessible by both parties. Interprise America will provide and place fiber cable at the point of interconnection of sufficient length to be pulled through conduit and into the splice location. Interprise America will provide and install a sufficient length of fire retardant riser cable, to which the entrance cable will be spliced, which will extend from the splice location to the Interprise America's equipment in the Collocation Space. In the event Interprise America utilizes a non-metallic, riser-type entrance facility, a splice will not be required. Interprise America must contact BellSouth for instructions prior to placing the entrance facility cable in the manhole. Interprise America is responsible for maintenance of the entrance facilities. At Interprise America's option BellSouth will accommodate where technically feasible a microwave entrance facility pursuant to separately negotiated terms and conditions.

5.2.1 Dual Entrance. BellSouth will provide at least two interconnection points at each central office premises where there are at least two such interconnection points available and where capacity exists. Upon receipt of a request for physical collocation under this Attachment, BellSouth shall provide Interprise America with information regarding BellSouth's capacity to accommodate dual entrance facilities. If conduit in the serving manhole(s) is available and is not reserved for another purpose for utilization within 12 months of the receipt of an application for collocation, BellSouth will make the requested conduit space available for installing a second entrance facility to Interprise America's arrangement. The location of the serving manhole(s) will be determined at the sole discretion of BellSouth. Where dual entrance is not available due to lack of capacity, BellSouth will so state in the Application Response.

5.2.2 Shared Use. Interprise America may utilize spare capacity on an existing Interconnector entrance facility for the purpose of providing an entrance facility to another Interprise America collocation arrangement within the same BellSouth Central Office. Interprise America must arrange with BellSouth for BellSouth to splice the utilized entrance facility capacity to Interprise America-provided riser cable.

5.3 Splicing in the Entrance Manhole. Although not generally permitted, should Interprise America request a splice to occur in the entrance manhole(s), BellSouth, at its sole discretion, may grant such a request, provided that BellSouth will not unreasonably withhold approval of requests to make such a splice. When the request for a splice is granted to Interprise America by BellSouth, Interprise America shall ensure its employees or agents entering and/or performing work in the entrance manhole(s) are trained and comply with BellSouth procedures and OSHA requirements regarding access to manholes and that BellSouth personnel are notified and present for all entrances and work performed in the entrance manhole(s). Manhole covers shall be properly closed and secured at the conclusion

of entry and/or work. Advance notification to BellSouth shall occur at a minimum of 48 hours prior to desired entry for normal work activities and at a minimum of 2 hours prior to desired entry in an out of service condition.

5.4 Demarcation Point. BellSouth will designate the point(s) of interconnection between Interprise America's equipment and/or network and BellSouth's network. Each party will be responsible for maintenance and operation of all equipment/facilities on its side of the demarcation point. For 2-wire and 4-wire connections to BellSouth's network, the demarcation point shall be a common block on the BellSouth designated conventional distributing frame. Interprise America shall be responsible for providing, and Interprise America's BellSouth Certified Vendor shall be responsible for installing and properly labelling/stenciling, the common block, and necessary cabling pursuant to Section 6.4. For all other terminations BellSouth shall designate a demarcation point on a per arrangement basis. Interprise America or its agent must perform all required maintenance to equipment/facilities on its side of the demarcation point, pursuant to subsection 5.5, following, and may self-provision cross-connects that may be required within the collocation space to activate service requests. At Interprise America's option, a Point of Termination (POT) bay or frame may be placed in the Collocation Space.

5.5 Interprise America's Equipment and Facilities. Interprise America, or if required by this Attachment, Interprise America's BellSouth certified vendor, is solely responsible for the design, engineering, installation, testing, provisioning, performance, monitoring, maintenance and repair of the equipment and facilities used by Interprise America. Such equipment and facilities may include but are not limited to cable(s); equipment; and point of termination connections.

5.6 Co-Carrier Cross-connect. In addition to, and not in lieu of, obtaining interconnection with, or access to, BellSouth telecommunications services, unbundled network elements, and facilities, Interprise America may directly connect to other Interconnectors within the designated BellSouth Central Office (including to its other virtual or physical collocated arrangements) through facilities owned by Interprise America or through BellSouth facilities designated by Interprise America, at Interprise America's option. Such connections to other carriers may be made using either optical or electrical facilities. Interprise America may deploy such optical or electrical connections directly between its own facilities and the facilities of other Interconnector(s) without being routed through BellSouth equipment.

5.6.1 If Interprise America requests a co-Carrier cross-connect after the initial installation, Interprise America must submit an application with a Subsequent Application Fee. Interprise America must use a Certified Vendor to place the co-Carrier cross connect, except in cases where the Interprise America equipment and the equipment of the other Interconnector are located within contiguous collocation spaces. In cases where Interprise America's equipment and the equipment of the other Interconnector are located in contiguous collocation spaces, Interprise America will have the option to deploy the co-Carrier cross connects between the sets of equipment. Where cable support structure exists for such connection there will be a recurring charge per linear foot of support structure used. When cable support structures do not exist and must be constructed a non-recurring charge for the individual case will be assessed.

5.7 Easement Space. From time to time BellSouth may require access to the Collocation Space. BellSouth retains the right to access such space for the purpose of making BellSouth equipment and building modifications (e.g., running, altering or removing racking,

ducts, electrical wiring, HVAC, and cables). BellSouth will give reasonable notice to Interprise America when access to the Collocation Space is required. Interprise America may elect to be present whenever BellSouth performs work in the Collocation Space. The Parties agree that Interprise America will not bear any of the expense associated with this work.

5.8 Access. Pursuant to Section 11, Interprise America shall have access to the Collocation Space twenty-four (24) hours a day, seven (7) days a week. Interprise America agrees to provide the name, social security number, and date of birth of each employee, contractor, or agents provided with Access Keys or cards ("Access Keys") prior to the issuance of said Access Keys. Access Keys shall not be duplicated under any circumstances. Interprise America agrees to be responsible for all Access Keys and for the return of all said Access Keys in the possession of Interprise America employees, contractors, Guests, or agents after termination of the employment relationship, contractual obligation with Interprise America or upon the termination of this Attachment or the termination of occupancy of an individual collocation arrangement.

5.8.1 Lost or Stolen Access Keys. Interprise America shall notify BellSouth in writing immediately in the case of lost or stolen Access Keys. Interprise America will pay BellSouth \$250.00 per Access Key(s) lost or stolen. Should it become necessary for BellSouth to re-key buildings as a result of a lost Access Key(s) or for failure to return an Access Key(s), Interprise America shall pay for all reasonable costs associated with the re-keying.

5.9 Interference or Impairment. Notwithstanding any other provisions of this Attachment, equipment and facilities placed in the Collocation Space shall not interfere with or impair service provided by BellSouth or by any other Interconnector located in the Central Office; shall not endanger or damage the facilities of BellSouth or of any other Interconnector, the Collocation Space, or the Central Office; shall not compromise the privacy of any communications carried in, from, or through the Central Office; and shall not create an unreasonable risk of injury or death to any individual or to the public. If BellSouth reasonably determines that any equipment or facilities of Interprise America violates the provisions of this paragraph, BellSouth shall give written notice to Interprise America, which notice shall direct Interprise America to cure the violation within forty-eight (48) hours of Interprise America's actual receipt of written notice or, at a minimum, to commence curative measures within 24 hours and to exercise reasonable diligence to complete such measures as soon as possible thereafter. After receipt of the notice, the parties agree to consult immediately and, if necessary, to inspect the arrangement. If Interprise America fails to take curative action within 48 hours or if the violation is of a character which poses an immediate and substantial threat of damage to property, injury or death to any person, or interference/impairment of the services provided by BellSouth or any other interconnector, then and only in that event BellSouth may take such action as it deems appropriate to correct the violation, including without limitation the interruption of electrical power to Interprise America's equipment. BellSouth will endeavor, but is not required, to provide notice to Interprise America prior to taking such action and shall have no liability to Interprise America for any damages arising from such action, except to the extent that such action by BellSouth constitutes willful misconduct.

5.10 Personalty and its Removal. Subject to requirements of this Attachment, Interprise America may place or install in or on the Collocation Space such facilities and equipment, including storage for and spare equipment, as it deems desirable for the conduct of business, provided that such equipment is telecommunications equipment, does not violate floor loading requirements, imposes or could impose or contains or could contain environmental

conditions or hazards. Personal property, facilities and equipment placed by Interprise America in the Collocation Space shall not become a part of the Collocation Space, even if nailed, screwed or otherwise fastened to the Collocation Space, but shall retain their status as personalty and may be removed by Interprise America at any time. Any damage caused to the Collocation Space by Interprise America's employees, agents or representatives during the removal of such property shall be promptly repaired by Interprise America at its expense.

5.11 Alterations. In no case shall Interprise America or any person acting on behalf of Interprise America make any rearrangement, modification, improvement, addition, repair, or other alteration to the Collocation Space or the BellSouth Central Office without the written consent of BellSouth, which consent shall not be unreasonably withheld. The cost of any such specialized alterations shall be paid by Interprise America.

5.12 Janitorial Service. Interprise America shall be responsible for the general upkeep and cleaning of the Caged Collocation Space and shall arrange directly with a BellSouth certified contractor for janitorial services. BellSouth shall provide a list of such contractors on a site-specific basis upon request.

6. ORDERING AND PREPARATION OF COLLOCATION SPACE

6.1 Application for Space. Interprise America shall submit an application document when Interprise America or Interprise America's Guest(s), as defined in Section 3.3, desires to request or modify the use of the Collocation Space.

6.1.1 Initial Application. For Interprise America or Interprise America's Guest(s) initial equipment placement, Interprise America shall submit to BellSouth a complete and accurate Application and Inquiry document (Bona Fide Application), together with payment of the Application Fee as stated in Exhibit A. The Bona Fide Application shall contain a detailed description and schematic drawing of the equipment to be placed in Interprise America's Collocation Space(s) and an estimate of the amount of square footage required.

6.1.2 Subsequent Application Fee. In the event Interprise America or Interprise America's Guest(s) desire to modify the use of the Collocation Space, Interprise America shall complete an Application document detailing all information regarding the modification to the Collocation Space together with payment of the minimum Subsequent Application Fee as stated in Exhibit A. Said minimum Subsequent Application Fee shall be considered a partial payment of the applicable Subsequent Application Fee which shall be calculated as set forth below. BellSouth shall determine what modifications, if any, to the Central Office premises are required to accommodate the change requested by Interprise America in the Application. Such necessary modifications to the Central Office premises may include but are not limited to, floor loading changes, changes necessary to meet HVAC requirements, changes to power plant requirements, and equipment additions. The fee paid by Interprise America for its request to modify the use of the Collocation Space shall be dependent upon the modification requested. Where the subsequent application does not require provisioning or construction work by BellSouth, no Subsequent Application Fee will be required and the pre-paid fee shall be refunded to Interprise America. The fee for an application where the modification requested has limited effect (e.g., does not require capital expenditure by BellSouth) shall be the Subsequent Application Fee as set forth in Exhibit A. All other modifications shall require a Subsequent Application Fee assessed at the applicable application fee. In the event such modifications

require the assessment of a full Application Fee as set forth in Exhibit A, the outstanding balance shall be due by Interprise America within 30 calendar days following Interprise America's receipt of a bill or invoice from BellSouth.

6.2 Application Response. In addition to the notice of space availability pursuant to Section 2.1, BellSouth will respond within ten (10) business days of receipt of an Application whether the Application is Bona Fide, and if it is not Bona Fide, the items necessary to cause the Application to become Bona Fide. When space has been determined to be available, BellSouth will provide a comprehensive written response within thirty (30) business days of receipt of a complete application. When multiple applications are submitted within a fifteen business day window, BellSouth will respond to the applications as soon as possible, but no later than the following: within thirty (30) business days for applications 1-5; within thirty-six (36) business days for applications 6-10; within forty-two (42) business days for applications 11-15. Response intervals for multiple applications submitted within the same timeframe for the same state in excess of 15 must be negotiated. All negotiations shall consider the total volume from all requests from telecommunications companies for collocation. The Application Response will detail whether the amount of space requested is available or if the amount of space requested is not available, the amount of space that is available. The response will also include the configuration of the space. When BellSouth's response includes an amount of space less than that requested by Interprise America or differently configured, Interprise America must amend its application to reflect the actual space available prior to submitting a Bona Fide Firm Order.

6.3 Bona Fide Firm Order. Interprise America shall indicate its intent to proceed with equipment installation in a BellSouth Central Office by submitting a Bona Fide Firm Order to BellSouth. A Bona Fide Firm Order requires Interprise America to complete the Application/Inquiry process described in Subsection 6.1, preceding, and submit the Expanded Interconnection Bona Fide Firm Order document (BSTEI-1P-F) indicating acceptance of the written application response provided by BellSouth ("Bona Fide Firm Order") and all appropriate fees. The Bona Fide Firm Order must be received by BellSouth no later than thirty (30) calendar days after BellSouth's response to Interprise America's Application/Inquiry. If Interprise America makes changes to its application in light of BellSouth's written Application Response, BellSouth will be required to re-evaluate and respond to the change(s). In this event, BellSouth's provisioning interval will not start until the re-evaluation and response to the change(s) is complete and the Bona Fide Firm Order is received by BellSouth and all appropriate fees and duties have been executed. If BellSouth needs to reevaluate Interprise America's application as a result of changes requested by Interprise America to Interprise America's original application, then BellSouth will charge Interprise America a fee based upon the additional engineering hours required to do the reassessment. Major changes such as requesting additional space or adding additional equipment may require Interprise America to resubmit the application with an application fee.

6.3.1 BellSouth will establish a firm order date, per request, based upon the date BellSouth is in receipt of a Bona Fide Firm Order. BellSouth will acknowledge the receipt of Interprise America's Bona Fide Firm Order within five (5) business days of receipt indicating that the Bona Fide Firm Order has been received. A BellSouth response to a Bona Fide Firm Order will include a Firm Order Confirmation containing the firm order date.

6.3.2 BellSouth will permit one accompanied site visit to Interprise America's designated collocation arrangement location after receipt of the Bona Fide Firm Order without charge to Interprise America.

6.3.3 Space preparation for the Collocation Space will not begin until BellSouth receives the Bona Fide Firm Order and all applicable fees.

6.3.4 Interprise America must submit to BellSouth the completed Access Control Request Form (RF-2906-A) for all employees or agents requiring access to the BellSouth Central Office a minimum of 30 calendar days prior to the date Interprise America desires access to the Collocation Space.

6.4 Construction and Provisioning Interval. BellSouth will negotiate construction and provisioning intervals per request on an individual case basis. Excluding the time interval required to secure the appropriate government licenses and permits, BellSouth will use best efforts to complete construction for collocation arrangements under ordinary conditions as soon as possible and within a maximum of 90 business days from receipt of a complete and accurate Bona Fide Firm Order. Ordinary conditions are defined as space available with only minor changes to support systems required, such as but not limited to, HVAC, cabling and the power plant(s). Excluding the time interval required to secure the appropriate government licenses and permits, BellSouth will use best efforts to complete construction of all other collocation space ("extraordinary conditions") within 130 business days of the receipt of a complete and accurate Bona Fide Firm Order. Extraordinary conditions are defined to include but are not limited to major BellSouth equipment rearrangement or addition; power plant addition or upgrade; major mechanical addition or upgrade; major upgrade for ADA compliance; environmental hazard or hazardous materials abatement.

6.4.1 Joint Planning Meeting. Unless otherwise agreed to by the Parties, a joint planning meeting or other method of joint planning between BellSouth and Interprise America will commence within a maximum of 15 business days from BellSouth's receipt of a Bona Fide Firm Order and the payment of agreed upon fees. At such meeting, the Parties will agree to the preliminary design of the Collocation Space and the equipment configuration requirements as reflected in the Application and affirmed in the Bona Fide Firm Order. The Collocation Space Completion time period will be provided to Interprise America during the joint planning meeting or as soon as possible thereafter. BellSouth will complete all design work following the joint planning meeting.

6.4.2 Permits. Each Party or its agents will diligently pursue filing for the permits required for the scope of work to be performed by that Party or its agents within 7 business days of the completion of finalized construction designs and specifications.

6.4.3 Acceptance Walk Through. Interprise America and BellSouth will complete an acceptance walk through of each Collocation Space requested from BellSouth by Interprise America. BellSouth will correct any deviations to Interprise America's original or jointly amended requirements within five (5) business days after the walk through, unless the Parties jointly agree upon a different time frame.

6.5 Use of Certified Vendor. Interprise America shall select a vendor which has been approved as a BellSouth Certified Vendor to perform all engineering and installation work required in the Collocation Space. In some cases, Interprise America must select separate

BellSouth Certified Vendors for transmission equipment, switching equipment and power equipment. BellSouth shall provide Interprise America with a list of Certified Vendors upon request. The Certified Vendor(s) shall be responsible for installing Interprise America's equipment and components, installing co-carrier cross connects, extending power cabling to the BellSouth power distribution frame, performing operational tests after installation is complete, and notifying BellSouth's equipment engineers and Interprise America upon successful completion of installation. The Certified Vendor shall bill Interprise America directly for all work performed for Interprise America pursuant to this Attachment and BellSouth shall have no liability for nor responsibility to pay such charges imposed by the Certified Vendor. BellSouth shall consider certifying Interprise America or any vendor proposed by Interprise America.

6.6 Alarm and Monitoring. BellSouth shall place environmental alarms in the Central Office for the protection of BellSouth equipment and facilities. Interprise America shall be responsible for placement, monitoring and removal of environmental and equipment alarms used to service Interprise America's Collocation Space. Upon request, BellSouth will provide Interprise America with applicable tariffed service(s) to facilitate remote monitoring of collocated equipment by Interprise America. Both parties shall use best efforts to notify the other of any verified environmental hazard known to that party. The parties agree to utilize and adhere to the Environmental Hazard Guidelines identified as Exhibit B attached hereto.

6.7 Basic Telephone Service. Upon request of Interprise America, BellSouth will provide basic telephone service to the Collocation Space under the rates, terms and conditions of the current tariff offering for the service requested.

6.8 Space Preparation. BellSouth shall pro rate the costs of any renovation or upgrade to Central Office space or support mechanisms which is required to accommodate physical collocation. Interprise America's pro rated share will be calculated by multiplying such cost by a percentage equal to the amount of square footage occupied by Interprise America divided by the total Central Office square footage receiving renovation or upgrade. For this section, support mechanisms provided by BellSouth may include, but not be limited to heating/ventilation/air conditioning (HVAC) equipment, HVAC duct work, cable support structure, fire wall(s), mechanical upgrade, asbestos abatement, or ground plane addition. Such renovation or upgrade will be evaluated and the charges assessed on a per Central Office basis. BellSouth will reimburse Interprise America in an amount equal to Interprise America reasonable, demonstrative and mitigated expenditures incurred as a direct result of delays to the completion and turnover dates caused by BellSouth.

6.9 Virtual Collocation Transition. BellSouth offers Virtual Collocation pursuant to the rates, terms and conditions set forth in its F.C.C. Tariff No. 1. For the interconnection to BellSouth's network and access to BellSouth unbundled network elements, Interprise America may purchase 2-wire and 4-wire Cross-Connects as set forth in Exhibit A, and Interprise America may place within its Virtual Collocation arrangements the telecommunications equipment set forth in Section 5.1. In the event physical collocation space was previously denied at a location due to technical reasons or space limitations, and that physical collocation space has subsequently become available, Interprise America may transition its virtual collocation arrangements to physical collocation arrangements and pay the appropriate non-recurring fees for physical collocation and for the rearrangement or reconfiguration of services terminated in the virtual collocation arrangement. In the event that BellSouth knows when additional space for physical collocation may become available at the location requested by Interprise America, such information will be provided to Interprise America in BellSouth's written

denial of physical collocation. To the extent that (i) physical collocation space becomes available to Interprise America within 180 days of BellSouth's written denial of Interprise America's request for physical collocation, and (ii) Interprise America was not informed in the written denial that physical collocation space would become available within such 180 days, then Interprise America may transition its virtual collocation arrangement to a physical collocation arrangement and will receive a credit for any nonrecurring charges previously paid for such virtual collocation credit for any Interprise America must arrange with a BellSouth certified vendor for the relocation of equipment from its virtual collocation space to its physical collocation space and will bear the cost of such relocation.

6.10 Cancellation. If, at anytime, Interprise America cancels its order for the Collocation Space(s), Interprise America will reimburse BellSouth for any expenses incurred up to the date that written notice of the cancellation is received. In no event will the level of reimbursement under this paragraph exceed the maximum amount Interprise America would have otherwise paid for work undertaken by BellSouth if no cancellation of the order had occurred.

6.11 Licenses. Interprise America, at its own expense, will be solely responsible for obtaining from governmental authorities, and any other appropriate agency, entity, or person, all rights, privileges, and licenses necessary or required to operate as a provider of telecommunications services to the public or to occupy the Collocation Space.

7. RATES AND CHARGES

7.1 Non-recurring Fees. In addition to the Application Fee referenced in Section 6, preceding, Interprise America shall remit payment of a Cable Installation Fee and one-half (1/2) of the estimated Space Preparation Fee, as applicable, coincident with submission of a Bona Fide Firm Order. The outstanding balance of the actual Space Preparation Fee shall be due thirty (30) calendar days following Interprise America's receipt of a bill or invoice from BellSouth. Once the installation of the initial equipment arrangement is complete, a subsequent application fee may apply (as described in Subsection 7.4, when Interprise America requests a modification to the arrangement.

7.2 Documentation. BellSouth shall provide documentation to establish the actual Space Preparation Fee. The Space Preparation Fee will be pro rated as prescribed in Section 6, preceding.

7.3 Cable Installation. Cable Installation Fee(s) are assessed per entrance fiber placed.

7.4 Floor Space. The floor space charge includes reasonable charges for lighting, heat, air conditioning, ventilation and other allocated expenses associated with maintenance of the Central Office but does not include amperage necessary to power Interprise America's equipment. When the Collocation Space is enclosed, Interprise America shall pay floor space charges based upon the number of square feet so enclosed. When the Collocation Space is not enclosed, Interprise America shall pay floor space charges based upon the following floor space calculation: [(depth of the equipment lineup in which the rack is placed) + (0.5 x maintenance aisle depth) + (0.5 x wiring aisle depth)] X (width of rack and spacers). For purposes of this calculation, the depth of the equipment lineup shall consider the footprint of

equipment racks plus any equipment overhang. BellSouth will assign unenclosed Collocation Space in conventional equipment rack lineups where feasible. In the event Interprise America's collocated equipment requires special cable racking, isolated grounding or other treatment which prevents placement within conventional equipment rack lineups, Interprise America shall be required to request an amount of floor space sufficient to accommodate the total equipment arrangement. Floor space charges are due beginning with the date on which BellSouth releases the Collocation Space for occupancy or on the date Interprise America first occupies the Collocation Space, whichever is sooner.

7.5 Power. BellSouth shall supply -48 Volt (-48V) DC power for Interprise America's Collocation Space within the central office premises and shall make available AC power at Interprise America's option for Adjacent Arrangement collocation.

7.5.1 Charges for -48V DC power will be assessed per ampere per month based upon the certified vendor engineered and installed power feed fused ampere capacity. Rates include redundant feeder fuse positions (A&B) and cable rack to Interprise America's equipment or space enclosure. When obtaining power from a BellSouth Battery Distribution Fuse Bay, fuses and power cables (A&B) must be engineered (sized), and installed by Interprise America's certified vendor. When obtaining power from a BellSouth Power Board, power cables (A&B) must be engineered (sized), and installed by Interprise America's certified power vendor. Interprise America's certified vendor must also provide a copy of the engineering power specification prior to the Commencement Date. In the event BellSouth shall be required to construct additional DC power plant or upgrade the existing DC power plant in a Central Office as a result of Interprise America's request to collocate in that Central Office ("Power Plant Construction"), Interprise America shall pay its pro-rata share of costs associated with the Power Plant Construction. The determination of whether Power Plant Construction is necessary shall be within BellSouth's sole, but reasonable, discretion. BellSouth shall comply with all BellCore (Telcordia) and ANSI Standards regarding power cabling, including BellCore (Telcordia) Network Equipment Building System (NEBS) Standard GR-63-CORE. BellSouth will notify Interprise America of the need for the Power Plant Construction and will estimate the costs associated with the Power Plant Construction if BellSouth were to perform the Power Plant Construction. The costs of power plant construction shall be pro-rated and shared among all who benefit from that construction. Interprise America shall pay BellSouth one-half of its prorata share of the estimated Power Plant Construction costs prior to commencement of the work. Interprise America shall pay BellSouth the balance due (actual cost less one-half of the estimated cost) within thirty (30) days of completion of the Power Plant Construction. Interprise America has the option to perform the Power Plant Construction itself; provided, however, that such work shall be performed by a BellSouth certified contractor and such contractor shall comply with BellSouth's guidelines and specifications. Where the Power Plant Construction results in construction of a new power plant room, upon termination of this Attachment Interprise America shall have the right to remove its equipment from the power plant room, but shall otherwise leave the room intact. Where the Power Plant Construction results in an upgrade to BellSouth's existing power plant, upon termination of this Attachment, such upgrades shall become the property of BellSouth.

7.5.2 Charges for AC power will be assessed per breaker ampere per month based upon the certified vendor engineered and installed power feed fused ampere capacity. Rates include the provision of commercial and standby AC power. When obtaining power from a BellSouth Service Panel, fuses and power cables must be engineered (sized), and installed by Interprise America's certified vendor. Interprise America's certified vendor must also provide

a copy of the engineering power specification prior to the Commencement Date. Charges for AC power shall be assessed pursuant to the rates specified in Exhibit A. AC power voltage and phase ratings shall be determined on a per location basis.

7.6 Security Escort. A security escort will be required whenever Interprise America or its approved agent desires access to the entrance manhole or must have access to the Central Office Premises after the one accompanied site visit allowed pursuant to subsection 6.2.2 prior to completing BellSouth's Security Training requirements and/or prior to Space Acceptance. Rates for a security escort are assessed in one-half (1/2) hour increments according to the schedule appended hereto as Exhibit A.

7.7 Rate "True-Up." The Parties agree that the prices reflected as interim herein shall be "trued-up" (up or down) based on final prices either determined by further agreement or by final order, including any appeals, in a proceeding involving BellSouth before the regulatory authority for the state in which the services are being performed or any other body having jurisdiction over this agreement (hereinafter "Commission"). Under the "true-up" process, the interim price for each service shall be multiplied by the volume of that service purchased to arrive at the total interim amount paid for that service ("Total Interim Price"). The final price for that service shall be multiplied by the volume purchased to arrive at the total final amount due ("Total Final Price"). The Total Interim Price shall be compared with the Total Final Price. If the Total Final Price is more than the Total Interim Price, Interprise America shall pay the difference to BellSouth. If the Total Final Price is less than the Total Interim Price, BellSouth shall pay the difference to Interprise America. Each party shall keep its own records upon which a "true-up" can be based and any final payment from one party to the other shall be in an amount agreed upon by the Parties based on such records. In the event of any disagreement as between the records or the Parties regarding the amount of such "true-up," the Parties agree that the Commission shall be called upon to resolve such differences.

7.8 Other. If no rate is identified in the contract, the rate for the specific service or function will be negotiated by the parties upon request by either party. Payment of all other charges under this Attachment shall be due thirty (30) days after receipt of the bill (payment due date). Interprise America will pay a late payment charge of one and one-half percent (1-1/2%) assessed monthly on any balance which remains unpaid after the payment due date.

8. INSURANCE

8.1 Interprise America shall, at its sole cost and expense, procure, maintain, and keep in force insurance as specified in this Article and underwritten by insurance companies licensed to do business in the states applicable under this Attachment and having a BEST Insurance Rating of B ++ X (B ++ ten).

8.2 Interprise America shall maintain the following specific coverage:

8.2.1 Commercial General Liability coverage in the amount of ten million dollars (\$10,000,000.00) or a combination of Commercial General Liability and Excess/Umbrella coverage totaling not less than ten million dollars (\$10,000,000.00). BellSouth shall be named as an ADDITIONAL INSURED on ALL applicable policies as specified herein.

8.2.2 Statutory Workers Compensation coverage and Employers Liability coverage in the amount of one hundred thousand dollars (\$100,000.00) each accident, one hundred thousand dollars (\$100,000.00) each employee by disease, and five hundred thousand dollars (\$500,000.00) policy limit by disease.

8.2.3 Interprise America may elect to purchase business interruption and contingent business interruption insurance, having been advised that BellSouth assumes no liability for loss of profit or revenues should an interruption of service occur.

8.3 The limits set forth in Subsection 6.2 above may be increased by BellSouth from time to time during the term of this Attachment upon thirty (30) days notice to Interprise America to at least such minimum limits as shall then be customary with respect to comparable occupancy of BellSouth structures.

8.4 All policies purchased by Interprise America shall be deemed to be primary and not contributing to or in excess of any similar coverage purchased by BellSouth. All insurance must be in effect on or before the date equipment is delivered to BellSouth's Central Office and shall remain in effect for the term of this Attachment or until all Interprise America's property has been removed from BellSouth's Central Office, whichever period is longer. If Interprise America fails to maintain required coverage, BellSouth may pay the premiums thereon and seek reimbursement of same from Interprise America.

8.5 Interprise America shall submit certificates of insurance reflecting the coverage required pursuant to this Section a minimum of ten (10) days prior to the commencement of any work in the Collocation Space. Failure to meet this interval may result in construction and equipment installation delays. Interprise America shall arrange for BellSouth to receive thirty (30) days advance notice of cancellation from Interprise America's insurance company. Interprise America shall forward a certificate of insurance and notice of cancellation to BellSouth at the following address:

BellSouth Telecommunications, Inc.
Attn.: Risk Management Coordinator
600 N. 19th Street, 18B3
Birmingham, Alabama 35203

8.6 Interprise America must conform to recommendations made by BellSouth's fire insurance company to the extent BellSouth has agreed to, or shall hereafter agree to, such recommendations.

8.7 Failure to comply with the provisions of this Section will be deemed a material breach of this Attachment.

9. MECHANICS LIENS

9.1 If any mechanics lien or other liens shall be filed against property of either party (BellSouth or Interprise America), or any improvement thereon by reason of or arising out of any labor or materials furnished or alleged to have been furnished or to be furnished to or for the other party or by reason of any changes, or additions to said property made at the request or under the direction of the other party, the other party directing or requesting those changes

shall, within thirty (30) days after receipt of written notice from the party against whose property said lien has been filed, either pay such lien or cause the same to be bonded off the affected property in the manner provided by law. The party causing said lien to be placed against the property of the other shall also defend, at its sole cost and expense, on behalf of the other, any action, suit or proceeding which may be brought for the enforcement of such liens and shall pay any damage and discharge any judgment entered thereon.

10. INSPECTIONS

10.1 BellSouth shall conduct an inspection of Interprise America's equipment and facilities in the Collocation Space(s) prior to the activation of facilities between Interprise America's equipment and equipment of BellSouth. BellSouth may conduct an inspection if Interprise America adds equipment and may otherwise conduct routine inspections at reasonable intervals mutually agreed upon by the Parties. BellSouth shall provide Interprise America with a minimum of forty-eight (48) hours or two (2) business days, whichever is greater, advance notice of all such inspections. All costs of such inspection shall be borne by BellSouth.

11. SECURITY AND SAFETY REQUIREMENTS

11.1 Only BellSouth employees, BellSouth certified vendors and authorized employees, authorized Guests, pursuant to Section 3.3, preceding, or authorized agents of Interprise America will be permitted in the BellSouth Central Office. Interprise America shall provide its employees and agents with picture identification which must be worn and visible at all times while in the Collocation Space or other areas in or around the Central Office. The photo identification card shall bear, at a minimum, the employee's name and photo, and the Interprise America name. BellSouth reserves the right to remove from its premises any employee of Interprise America not possessing identification issued by Interprise America. Interprise America shall hold BellSouth harmless for any damages resulting from such removal of its personnel from BellSouth premises. Interprise America shall be solely responsible for ensuring that any Guest of Interprise America is in compliance with all subsections of this Section 11.

11.1.1 Interprise America will be required, at its own expense, to conduct a statewide investigation of criminal history records for each Interprise America employee being considered for work on the BellSouth Central Office, for the states/counties where the Interprise America employee has worked and lived for the past five years. Where state law does not permit statewide collection or reporting, an investigation of the applicable counties is acceptable.

11.1.2 Interprise America will be required to administer to their personnel assigned to the BellSouth Central Office security training either provided by BellSouth, or meeting criteria defined by BellSouth.

11.1.3 Interprise America shall not assign to the BellSouth Central Office any personnel with records of felony criminal convictions. Interprise America shall not assign to the BellSouth Central Office any personnel with records of misdemeanor convictions, without advising BellSouth of the nature and gravity of the offense(s). BellSouth reserves the right to

refuse building access to any Interprise America personnel who have been identified to have misdemeanor criminal convictions.

11.1.4 For each Interprise America employee requiring access to a BellSouth Central Office pursuant to this agreement, Interprise America shall furnish BellSouth, prior to an employee gaining such access, a notarized affidavit certifying that the aforementioned background check and security training were completed. The affidavit will contain a statement certifying no felony convictions were found and certifying that the security training was completed by the employee. If the employee's criminal history includes misdemeanor convictions, Interprise America will disclose the nature of the convictions to BellSouth at that time.

11.1.5 At BellSouth's request, Interprise America shall promptly remove from the BellSouth's premises any employee of Interprise America BellSouth does not wish to grant access to its premises pursuant to any investigation conducted by BellSouth.

11.2 Notification to BellSouth. BST reserves the right to interview Interprise America's employees, agents, or contractors. Interprise America and its contractors shall cooperate fully with BellSouth's investigation into allegations of wrongdoing or criminal conduct committed by or involving Interprise America's employees, agents, or contractors. Additionally, BellSouth reserves the right to bill Interprise America for all costs associated with investigations involving its employees, agents, or contractors if it can be reasonably established that Interprise America's employees, agents, or contractors are responsible for the alleged act. BellSouth shall bill Interprise America for BellSouth property which is stolen or damaged where an investigation determines the culpability of Interprise America's employees, agents, or contractors. Interprise America shall notify BellSouth in writing immediately in the event that the CLEC discovers one of its employees already working on the BellSouth premises is a possible security risk. BellSouth reserves the right to permanently remove from its premises any employee of Interprise America identified as posing a security risk to BellSouth or any other CLEC, or having violated BellSouth policies set forth in the BellSouth CLEC Security Training. Interprise America shall hold BellSouth harmless for any damages resulting from such removal of its personnel from BellSouth premises.

11.3 Use of BellSouth Supplies by Interprise America Employees. Use of any BellSouth supplies by a Interprise America employee, whether or not used routinely to provide telephone service (e.g. plug-in cards,) will be considered theft and will be handled accordingly. Costs associated with such unauthorized use of BellSouth property may be charged to Interprise America as may be all associated investigative costs. At BellSouth's request, Interprise America shall promptly and permanently remove from BellSouth's Central Office any employee of Interprise America found to be in violation of this rule.

11.4 Use of Official Lines by Interprise America Employees. Except for local calls necessary in the performance of their work, Interprise America employees shall not use the telephones on BellSouth Central Office. Charges for unauthorized telephone calls made by a Interprise America's employees may be charged to Interprise America as may be all associated investigative costs. At BellSouth's request, Interprise America shall promptly and permanently remove from BellSouth's premises any employee of Interprise America found to be in violation of this rule.

11.5 Accountability. Full compliance with the Security requirements of this section shall in no way limit the accountability of any CLEC for the improper actions of its employees.

12. DESTRUCTION OF COLLOCATION SPACE

12.1 In the event a Collocation Space is wholly or partially damaged by fire, windstorm, tornado, flood or by similar causes to such an extent as to be rendered wholly unsuitable for Interprise America's permitted use hereunder, then either party may elect within ten (10) days after such damage, to terminate this Attachment, and if either party shall so elect, by giving the other written notice of termination, both parties shall stand released of and from further liability under the terms hereof. If the Collocation Space shall suffer only minor damage and shall not be rendered wholly unsuitable for Interprise America's permitted use, or is damaged and the option to terminate is not exercised by either party, BellSouth covenants and agrees to proceed promptly without expense to Interprise America, except for improvements not the property of BellSouth, to repair the damage. BellSouth shall have a reasonable time within which to rebuild or make any repairs, and such rebuilding and repairing shall be subject to delays caused by storms, shortages of labor and materials, government regulations, strikes, walkouts, and causes beyond the control of BellSouth, which causes shall not be construed as limiting factors, but as exemplary only. Interprise America may, at its own expense, accelerate the rebuild of its collocated space and equipment provided however that a certified vendor is used and the necessary space preparation has been completed. Rebuild of equipment must be performed by a BellSouth Certified Vendor. If Interprise America's acceleration of the project increases the cost of the project, then those additional charges will be incurred by Interprise America. Where allowed and where practical, Interprise America may erect a temporary facility while BellSouth rebuilds or makes repairs. In all cases where the Collocation Space shall be rebuilt or repaired, Interprise America shall be entitled to an equitable abatement of rent and other charges, depending upon the unsuitability of the Collocation Space for Interprise America's permitted use, until such Collocation Space is fully repaired and restored and Interprise America's equipment installed therein (but in no event later than thirty (30) days after the Collocation Space is fully repaired and restored). Where Interprise America has placed an Adjacent Arrangement pursuant to section 3.4, Interprise America shall have the sole responsibility to repair or replace said Adjacent Arrangement provided herein. Pursuant to this section, BellSouth will restore the associated services to the Adjacent Arrangement.

13. EMINENT DOMAIN

13.1 If the whole of a Collocation Space or Adjacent Arrangement shall be taken by any public authority under the power of eminent domain, then this Attachment shall terminate as of the day possession shall be taken by such public authority and rent and other charges for the Collocation Space or Adjacent Arrangement shall be paid up to that day with proportionate refund by BellSouth of such rent and charges as may have been paid in advance for a period subsequent to the date of the taking. If any part of the Collocation Space or Adjacent Arrangement shall be taken under eminent domain, BellSouth and Interprise America shall each have the right to terminate this Attachment and declare the same null and void, by written notice of such intention to the other party within ten (10) days after such taking.

14. NONEXCLUSIVITY

12.1 Interprise America understands that this Attachment is not exclusive and that BellSouth may enter into similar agreements with other parties. Assignment of space pursuant to all such agreements shall be determined by space availability and made on a first come, first served basis.

**EXHIBIT A: BELLSOUTH/Interprise America RATES – ALABAMA
PHYSICAL COLLOCATION**

Rates marked with an asterisk (*) are interim and are subject to true-up

USOC	Rate Element Description	Unit	Recurring Rate (RC)	Non-Recurring Rate (NRC)
PE1BA	Application Fee	Per Request	NA	\$7,124.00 Disconnect Charge \$1.73
PE1CA	Subsequent Application Fee (Note 1)	Per Request	NA	\$1600.00 Minimum
PE1BB	Space Preparation Fee (Note 2)			
	Mechanical / HVAC*	Per ton (one ton minimum)		\$2,400.00
	Ground Bar*	Per Connection		\$720.00
	Project Management*	Per arrangement		\$1675.00
	Cable Racking / Fiber Duct	Per arrangement, square foot		ICB
	Frame / Aisle Lighting	Per arrangement, square foot		ICB
	Framework Ground Conductors	Per arrangement		ICB
	Extraordinary Modifications	Per arrangement		ICB
	Space Enclosure (Note 3) <i>Requested Prior to 6/1/99</i>			
PE1BW	Welded Wire-mesh	Per first 100 sq. ft.	\$189.86	NA
PE1CW	Welded Wire-mesh	Per add'l 50 sq. ft.	\$19.28	NA
PE1PJ	Floor Space	Per square foot	\$3.85	NA
PE1BD	Cable Installation	Per Cable	NA	\$2,335.00 Disconnect Charge \$54.39
PE1PM	Cable Support Structure	Per entrance cable	\$23.23	NA

**EXHIBIT A: BELLSOUTH/Interprise America RATES - ALABAMA
PHYSICAL COLLOCATION (cont.)**

USOC	Rate Element Description	Unit	Recurring Rate (RC)	Non-Recurring Rate (NRC)
PE1PL	Power -48V DC Power 120V AC Power single phase* 240V AC Power single phase* 120V AC Power three phase* 277V AC Power three phase*	Per amp Per breaker amp Per breaker amp Per breaker amp Per breaker amp	\$7.14 \$5.50 \$11.00 \$16.50 \$38.20	ICB ICB ICB ICB ICB
PE1P2 PE1P4 PE1P1 PE1P3 PE1F2 PE1F4	Cross Connects (Note 4) 2-wire 4-wire DS-1 DS-3 2-fiber 4-fiber	Per Cross Connect	\$.28 \$.56 \$2.14 \$38.63 \$10.44 \$18.76	First / Additional \$30.76 / \$29.40 \$31.01 / \$29.58 \$60.81 / \$41.71 \$57.80 / \$39.81 \$73.00 / \$52.00 \$88.00 / \$67.00
	2-wire 4-wire DS-1 DS-3			Disconnect Charges First / Additional \$12.75 / \$11.38 \$12.82 / \$11.39 \$12.85 / \$11.50 \$14.93 / \$11.76
PE1ES Fiber PE1DS Copper	Co-Carrier Cross-Connect (Note 5) Fiber Arrangement Copper or Coaxial	Cable Support Structure, per linear foot (existing) Cable Support Structure (new)	\$0.06 \$0.03 NA	NA NA ICB
PE1A1	Security Access System Security system* New Access Card Activation* Administrative change, existing card* Replace lost or stolen card*	Per Central Office Per Card Per Card Per Card	\$52.00	\$55.00 \$35.00 \$250.00
	Space Availability Report*	Per Central Office Requested		\$550.00

**EXHIBIT A: BELLSOUTH/Interprise America RATES - ALABAMA
PHYSICAL COLLOCATION (cont.)**

USOC	Rate Element Description	Unit	Recurring Rate (RC)	Non-Recurring Rate (NRC)
	POT Bay Arrangements <i>Prior to 6/1/99</i>	Per Cross Connect		
PE1PE	2 Wire Cross-Connect		\$0.08	NA
PE1PF	4 Wire Cross-Connect		\$0.17	NA
PE1PG	DS1 Cross-Connect		\$0.69	NA
PE1PH	DS3 Cross-Connect		\$4.74	NA
PE1B2	2 Fiber Cross-Connect		\$25.89	NA
PE1B4	4 Fiber Cross-Connect		\$34.91	NA
AEH	Additional Engineering Fee (Note 6)	Per request, First half hour/Add'l Half hour		First / Additional Basic Time - \$31.00 / \$22.00 Overtime - \$37.00 / \$26.00
	Security Escort			
PE1BT	Basic Time	Per 1/2	NA	\$43.47/\$25.82
PE1OT	Overtime	hour/Additional	NA	\$55.25/\$32.79
PE1PT	Premium Time	Half-hour	NA	\$67.03/\$39.76

EXHIBIT A: BELLSOUTH/!nterprise America RATES - ALABAMA
PHYSICAL COLLOCATION (cont.)

Note(s):

N/A refers to rate elements which do not have a negotiated rate.

- (1) **Subsequent Application Fee:** BellSouth requires the submission of an Application Fee for modifications to an existing arrangement. However, when the modifications do not require BellSouth to expend capital, BellSouth will assess the Subsequent Application Fee in lieu of the Application Fee. Proposed modifications that could result in assessment of a Subsequent Application Fee would cause BellSouth to analyze the following but are not limited to: floor loading changes, changes to HVAC requirements, power requirement changes which may result in a power plant upgrade, environmental or safety requirements, or equipment relocation. Should the Subsequent Application Fee not be included as part of this Attachment, !nterprise America will be assessed the full Application Fee for all subsequent activity for completed arrangements.
- (2) **Space Preparation Fee:** The Space Preparation Fee is a one-time fee, assessed per arrangement, per location. It recovers the costs associated with the shared physical collocation area within a Central Office, which include survey, engineering, design and modification costs for network, building and support systems. In the event !nterprise America opts for non-enclosed space, the space preparation fee will be assessed based on the total floor space dedicated to !nterprise America as prescribed in Section 7 of the Collocation Attachment.
- (3) **Space Enclosure:** For cages requested prior to June 1, 1999, the Space Enclosure Construction Fee is a monthly recurring fee, assessed per enclosure, per location with a one-hundred (100) square foot minimum enclosure. It recovers costs associated with providing an optional equipment arrangement enclosure, which include architectural and engineering fees, materials, and installation costs. The cost for additional square feet is applicable only when ordered with the first 100 square feet and must be requested in fifty (50) square foot increments. !nterprise America may, at its option, arrange with a BellSouth certified contractor to construct the space enclosure in accordance with BellSouth's guidelines and specifications. In this event, the contractor shall directly bill !nterprise America for the space enclosure, and this fee shall not be applicable.
- (4) **Cross Connects:** The charges for cross connects are for orders placed electronically. Cross connect elements may also be ordered manually for which there is an additional charge per element.

	First / Additional	Disconnect Charges First / Additional
2-wire	\$34.03 / \$32.67	\$14.48 / \$13.11
4-wire	\$34.28 / \$32.85	\$14.55 / \$13.12
DS-1	\$64.08 / \$44.98	\$14.58 / \$13.23
DS-3	\$61.07 / \$43.08	\$16.66 / \$13.49

- (5) **Co-Carrier Cross-Connect:** As stated in Section 1.2 of the Collocation Attachment, !nterprise America may connect to other CLECs within the designated Central Office in addition to, and not in lieu of, interconnection to BellSouth services and facilities. Where BellSouth must construct a cable rack structure to house the co-Carrier cross connection, construction charges will be applied on an individual case basis. BellSouth shall provide an estimate of these charges in the Application Response. Where an existing cable rack structure is in place and has sufficient capacity to accommodate the co-Carrier cross connection requested, the recurring charges as stated in this Exhibit A shall apply.
- (6) **Additional Engineering Fee:** BellSouth's additional engineering, and other labor costs associated with handling !nterprise America-requested modifications to requests in progress or augmentations to existing arrangements shall be recovered as Additional Engineering charges, under provisions in BellSouth's F.C.C. Number 1 Tariff, Sections 13.1 and 13.2. Should Additional Engineering rates not be included, !nterprise America agrees not to make changes to collocation arrangement after a Bona Fide Firm Order is submitted.

**EXHIBIT A: BELLSOUTH/Interprise America RATES - FLORIDA
PHYSICAL COLLOCATION**

Rates marked with an asterisk (*) are interim and are subject to true-up

USOC	Rate Element Description	Unit	Recurring Rate (RC)	Non-Recurring Rate (NRC)
PE1BA	Application Fee	Per Request	\$15.53	\$3,248.00
PE1CA	Subsequent Application Fee (Note 1)	Per Request	NA	\$1600.00 Minimum
PE1BB	Space Preparation Fee (Note 2)			
	Mechanical / HVAC*	Per ton (one ton minimum)		\$2,400.00
	Ground Bar*	Per Connection		\$720.00
	Project Management*	Per arrangement		\$1675.00
	Cable Racking / Fiber Duct	Per arrangement, square foot		ICB
	Frame / Aisle Lighting	Per arrangement, square foot		ICB
	Framework Ground Conductors	Per arrangement		ICB
	Extraordinary Modifications	Per arrangement		ICB
	Space Enclosure (Note 3) <i>Requested Prior to 6/1/99</i>			
PE1BW	Wire Cage	Per first 100 sq. Ft.	\$41.99	NA
PE1BC	Gypsum Board Cage	Per first 100 sq. Ft.	\$84.10	NA
PE1BF	Fire Rated Cage	Per first 100 sq. Ft.	\$99.73	NA
PE1CW	Wire Cage	Per add'l 50 sq. Ft.	\$4.14	NA
PE1CC	Gypsum Board Cage	Per add'l 50 sq. Ft.	\$9.35	NA
PE1CF	Fire Rated Cage	Per add'l 50 sq. Ft.	\$11.30	NA
PE1PJ	Floor Space	Per sq. Ft.	\$4.25	NA
PE1BD	Cable Installation	Per Cable	\$2.77	\$1,056.00
PE1PM	Cable Support Structure		\$22.94	NA

**EXHIBIT A: BELLSOUTH/Interprise America RATES - FLORIDA
PHYSICAL COLLOCATION (cont.)**

USOC	Rate Element Description	Unit	Recurring Rate (RC)	Non-Recurring Rate (NRC)
PE1PL	Power -48V DC Power 120V AC Power single phase * 240V AC Power single phase* 120V AC Power three phase* 277V AC Power three phase*	Per amp Per breaker amp Per breaker amp Per breaker amp Per breaker amp	\$7.14 \$5.50 \$11.00 \$16.50 \$38.20	ICB ICB ICB ICB ICB
PE1P2 PE1P4	Cross Connects (Note 4) 2-wire 4-wire	Per Cross Connect	\$0.0524 \$0.0524	\$11.57 \$11.57
PE11S PE11X	DS-1/DCS DS-1/DSX		\$8.085 \$.4110	\$69.64 \$69.64
PE13S PE13X	DS-3/DCS DS-3/DSX		\$56.97 \$10.06	\$528.00 \$528.00
PE1F2	Optical Cross Connects		\$6.46	\$2,431.00
PE1ES PE1DS (TBD)	Co-Carrier Cross-Connect (Note 5) Fiber Cable Support Structure, existing Copper or Coaxial Cable Support Structure, existing Cable Support Structure Construction, new	Per linear foot Per linear foot Per new construction	\$0.06 \$0.03 NA	NA NA ICB
PE1A2	Security Access System Security System* New Access Card Activation* Administrative change, existing card* Replace lost or stolen card*	Per Central Office Per request-5 cards Per Card Per Card	\$95.00 NA	\$85.12 \$35.00 \$250.00
	Space Availability Report *	Per Central Office Requested		\$550.00
	POT Bay (Note 6)		NA	NA

**EXHIBIT A: BELLSOUTH/Interprise America RATES - FLORIDA
PHYSICAL COLLOCATION (cont.)**

USOC	Rate Element Description	Unit	Recurring Rate (RC)	Non-Recurring Rate (NRC)
AEH	Additional Engineering Fee (Note 7)	Per request, First half hour/Add'l half hour		First /Add'l Basic Time - \$31.00/\$22.00 Overtime - \$37.00/\$26.00
	Security Escort			
	Basic Time	Per ¼ hour	NA	\$10.89
	Overtime	Per ¼ hour	NA	\$13.64
	Premium Time	Per ¼ hour	NA	\$16.40

Note(s):

N/A refers to rate elements which do not have a negotiated rate.

- (1) **Subsequent Application Fee:** BellSouth requires the submission of an Application Fee for modifications to an existing arrangement. However, when the modifications do not require BellSouth to expend capital, BellSouth will assess the Subsequent Application Fee in lieu of the Application Fee. Proposed modifications that could result in assessment of a Subsequent Application Fee would cause BellSouth to analyze the following but are not limited to: floor loading changes, changes to HVAC requirements, power requirement changes which may result in a power plant upgrade, environmental or safety requirements, or equipment relocation. Should the Subsequent Application Fee not be included as part of this Attachment, Interprise America will be assessed the full Application Fee for all subsequent activity for completed arrangements.
- (2) **Space Preparation Fee:** The Space Preparation Fee is a one-time fee, assessed per arrangement, per location. It recovers costs associated with the shared physical collocation area within a Central Office, which include survey, engineering, design and modification costs for network, building and support systems. BellSouth will pro rate the total shared space preparation costs among the collocators at each location based on the amount of square footage occupied by each collocator. This charge may vary depending on the location and type of arrangement requested.
- (3) **Space Enclosure Fee:** For cages requested prior to June 1, 1999, the Space Enclosure Construction Fee is a monthly recurring fee, assessed per enclosure, per location with a one-hundred (100) square foot minimum enclosure. It recovers costs associated with providing an optional equipment arrangement enclosure, which include architectural and engineering fees, materials, and installation costs. The cost for additional square feet is applicable only when ordered with the first 100 square feet and must be requested in fifty (50) square foot increments. Interprise America may, at its option, arrange with a BellSouth certified contractor to construct the space enclosure in accordance with BellSouth's guidelines and specifications. In this event, the contractor shall directly bill Interprise America for the space enclosure, and this fee shall not be applicable.
- (4) **Cross Connects:** Rates shown are the equivalent per cross connect rates based on the Florida PSC Ordered rates as follows:

<u>Cross Connects</u>	<u>Per Cross Connect</u>	<u>RC</u>	<u>NRC</u>
2-wire	Per 100 X-Connects	\$5.24	\$1,157.00
4-wire	Per 100 X-Connects	\$5.24	\$1,157.00
DS-1/DCS	Per 28 X-Connects	\$226.39	\$1,950.00
DS-1/DSX	Per 28 X-Connects	\$11.51	\$1,950.00
DS-3/DCS	Per Cross Connect	\$56.97	\$ 528.00
DS-3/DSX	Per Cross Connect	\$10.06	\$528.00
Optical Cross Connects	Per Cross Connect	\$6.46	\$2,431.00

EXHIBIT A: BELLSOUTH/Interprise America RATES - FLORIDA
PHYSICAL COLLOCATION (cont.)

- (5) **Co-Carrier Cross-Connect.** As stated in Section 5 of the Collocation Attachment, Interprise America may connect to other CLECs within the designated Central Office in addition to, and not in lieu of, interconnection to BellSouth services and facilities. Where BellSouth must construct a cable rack structure to house the direct connection, construction charges will be applied on an individual case basis. BellSouth shall provide an estimate of these charges in the Application Response. Where an existing cable rack structure is in place and has sufficient capacity to accommodate the direct connection requested, the recurring charges as stated in this Exhibit A shall apply.
- (6) **POT Bays:** BellSouth's Florida specific rates were established in the Florida Public Service Commission Docket No. 960833. The Commission did not set permanent rates for POT Bays, given the assumption by the parties to the Proceeding that they will always provide their own POT Bays. It will be necessary for Interprise America to provide its own POT Bays per BellSouth specifications and provide the necessary information from which BellSouth can inventory.
- (7) **Additional Engineering Fee:** BellSouth's additional engineering, and other labor costs associated with handling Interprise America-requested modifications to requests in progress or augmentations to existing arrangements shall be recovered as Additional Engineering charges, under provisions in BellSouth's F.C.C. Number 1 Tariff, Sections 13.1 and 13.2. Should Additional Engineering rates not be included, Interprise America agrees not to make changes to collocation arrangement after a Bona Fide Firm Order is submitted.

**EXHIBIT A: BELLSOUTH/Interprise America RATES - GEORGIA
PHYSICAL COLLOCATION**

Rates marked with an asterisk (*) are interim and subject to true-up

USOC	Rate Element Description	Unit	Recurring Rate (RC)	Non-Recurring Rate (NRC)
PE1BA	Application Fee	Per Request	NA	\$3,850.00
PE1CA	Subsequent Application Fee (Note 1)	Per Request	NA	\$1600.00 Minimum
PE1BB	Space Preparation Fee (Note 2)	Per square foot	NA	\$100.00
PE1BW PE1CW	Space Enclosure (Note 3) <i>Cages Prior to 6/1/99</i> Welded Wire-mesh Welded Wire-mesh	Per first 100 sq. ft. Per add'l 50 sq. ft.	\$170.64 \$17.33	NA NA
PE1PJ PE1PK	Floor Space Zone A Zone B	Per square foot Per square foot	\$7.50 \$6.75	NA NA
PE1BD	Cable Installation	Per Cable	NA	\$2,750.00
PE1PM	Cable Support Structure	Per entrance cable	\$13.35	NA
PE1PL	Power -48V DC Power 120V AC Power single phase* 240V AC Power single phase* 120V AC Power three phase* 277V AC Power three phase*	Per amp Per breaker amp Per breaker amp Per breaker amp Per breaker amp	\$7.14 \$5.50 \$11.00 \$16.50 \$38.20	ICB ICB ICB ICB ICB
PE1P2 PE1P4 PE1P1 PE1P3 PE1F2 PE1F4	Cross Connects 2-wire 4-wire DS-1 DS-3 2-fiber 4-fiber	Per Cross Connect	\$.30 \$.50 \$8.00 \$72.00 \$10.29 \$18.50	First / Additional \$12.60 / \$12.60 \$12.60 / \$12.60 \$155.00 / \$27.00 \$155.00 / \$27.00 \$73.00 / \$52.00 \$88.00 / \$67.00

**EXHIBIT A: BELLSOUTH/Interprise America RATES - GEORGIA
PHYSICAL COLLOCATION (cont.)**

USOC	Rate Element Description	Unit	Recurring Rate (RC)	Non-Recurring Rate (NRC)
PE1ES	Co-Carrier Cross-Connect (Note 4) Fiber Cable Support Structure, existing	Per linear foot	\$0.06	NA
PE1DS	Copper or Coaxial Cable Support Structure, existing	Per linear foot	\$0.03	NA
(TBD)	Cable Support Structure Construction, new	Per new construction	NA	ICB
PE1A1	Security Access System Security system* New Access Card Activation* Administrative change, existing card* Replace lost or stolen card*	Per Central Office Per Card Per Card Per Card	\$52.00	\$55.00 \$35.00 \$250.00
	Space Availability Report*	Per Central Office Requested		\$550.00
PE1PE	POT Bay Arrangements <i>Prior to 6/1/99</i> 2 Wire Cross-Connect	Per Cross Connect	\$0.40	NA
PE1PF	4 Wire Cross-Connect		\$1.20	NA
PE1PG	DS1 Cross-Connect		\$1.20	NA
PE1PH	DS3 Cross-Connect		\$8.00	NA
PE1B2	2 Fiber Cross-Connect		\$25.53	NA
PE1B4	4 Fiber Cross-Connect		\$34.43	NA
AEH	Additional Engineering Fee (Note 5)	Per request, First half hour/Add'l Half hour		First /Add'l Basic Time - \$31.00/\$22.00 Overtime - \$37.00/\$26.00
PE1BT	Security Escort Basic Time	Per 1/2 hour/Additional	NA	\$41.00/\$25.00
PE1OT	Overtime	Half-hour	NA	\$48.00/\$30.00
PE1PT	Premium Time		NA	\$55.00/\$35.00

**EXHIBIT A: BELLSOUTH/Interprise America RATES - GEORGIA
PHYSICAL COLLOCATION (cont.)**

Note(s)

N/A refers to rate elements which do not have a negotiated rate.

- (1) **Subsequent Application Fee:** BellSouth requires the submission of an Application Fee for modifications to an existing arrangement. However, when the modifications do not require BellSouth to expend capital, BellSouth will assess the Subsequent Application Fee in lieu of the Application Fee. Proposed modifications that could result in assessment of a Subsequent Application Fee would cause BellSouth to analyze the following but are not limited to: floor loading changes, changes to HVAC requirements, power requirement changes which may result in a power plant upgrade, environmental or safety requirements, or equipment relocation. Should the Subsequent Application Fee not be included as part of this Attachment, Interprise America will be assessed the full Application Fee for all subsequent activity for completed arrangements.
- (2) **Space Preparation Fee:** The Space Preparation Fee is a one-time fee, assessed per arrangement, per location. It recovers a portion of costs associated with the shared physical collocation area within a Central Office, which include survey, engineering, design and modification costs for network, building and support systems. This is a set fee of \$100 per square foot as established by the Georgia Public Service Commission Order in Docket No. 7061-U. In the event Interprise America opts for non-enclosed space, the space preparation fee will be assessed based on the total floor space dedicated to Interprise America as prescribed in Section 7 of the Collocation Attachment.
- (3) **Space Enclosure Fee:** For cages requested prior to June 1, 1999, the Space Enclosure Construction Fee is a one-time fee, assessed per enclosure, per location with a one-hundred (100) square foot minimum enclosure. It recovers costs associated with providing an optional equipment arrangement enclosure, which include architectural and engineering fees, materials, and installation costs. The cost for additional square feet is applicable only when ordered with the first 100 square feet and must be requested in fifty (50) square foot increments. Interprise America may, at its option, arrange with a BellSouth certified contractor to construct the space enclosure in accordance with BellSouth's guidelines and specifications. In this event, the contractor shall directly bill Interprise America for the space enclosure, and this fee shall not be applicable.
- (4) **Co-Carrier Cross-Connect.** As stated in Section 5 of the Collocation Attachment, Interprise America may connect to other CLECs within the designated Central Office in addition to, and not in lieu of, interconnection to BellSouth services and facilities. Where BellSouth must construct a cable rack structure to house the co-Carrier cross connection, construction charges will be applied on an individual case basis. BellSouth shall provide an estimate of these charges in the Application Response. Where an existing cable rack structure is in place and has sufficient capacity to accommodate the co-Carrier cross-connection requested, the recurring charges as stated in this Exhibit A shall apply.
- (5) **Additional Engineering Fee:** BellSouth's additional engineering, and other labor costs associated with handling Interprise America-requested modifications to requests in progress or augmentations to existing arrangements shall be recovered as Additional Engineering charges, under provisions in BellSouth's F.C.C. Number 1 Tariff, Sections 13.1 and 13.2. Should Additional Engineering rates not be included, Interprise America agrees not to make changes to collocation arrangement after a Bona Fide Firm Order is submitted.

**EXHIBIT A: BELLSOUTH/Interprise America RATES - KENTUCKY
PHYSICAL COLLOCATION**

Rates marked with an asterisk (*) are interim and are subject to true-up.

USOC	Rate Element Description	Unit	Recurring Rate (RC)	Non-Recurring Rate (NRC)
PE1BA	Application Fee	Per Request	NA	\$9,926.72
PE1CA	Subsequent Application Fee (Note 1)	Per Request	NA	\$1600.00 Minimum
PE1BB	Space Preparation Fee (Note 2)			
	Mechanical / HVAC*	Per ton (one ton minimum)		\$2,400.00
	Ground Bar*	Per Connection		\$720.00
	Project Management*	Per arrangement		\$1,675.00
	Cable Racking/Fiber Duct	Per arrangement, per square foot		ICB
	Frame / Aisle lighting	Per arrangement, per square foot		ICB
	Framework Ground Conductors	Per arrangement		ICB
	Extraordinary Modifications	Per arrangement		ICB
PE1BW PE1CW	Space Enclosure (Note 3) <i>Prior to 6/1/99</i>			
	Welded Wire-mesh	Per first 100 sq. ft.	\$201.02	NA
	Welded Wire-mesh	Per add'l 50 sq. ft.	\$20.42	NA
PE1PJ	Floor Space	Per square foot	\$5.00	NA
PE1BD	Cable Installation	Per Cable	NA	\$2,327.08
PE1PM	Cable Support Structure	Per entrance cable	\$24.23	NA
PE1PL	Power			
	-48V DC Power	Per amp	\$7.68	ICB
	120V AC Power single phase*	Per breaker amp	\$5.50	ICB
	240V AC Power single phase*	Per breaker amp	\$11.00	ICB
	120V AC Power three phase*	Per breaker amp	\$16.50	ICB
	277V AC Power three phase*	Per breaker amp	\$38.20	ICB

**EXHIBIT A: BELLSOUTH/Interprise America RATES - KENTUCKY
PHYSICAL COLLOCATION (cont.)**

USOC	Rate Element Description	Unit	Recurring Rate (RC)	Non-Recurring Rate (NRC)
PE1P2	Cross Connects 2-wire	Per Cross Connect	\$.31	First / Additional \$54.21/\$51.07
PE1P4	4-wire		\$.62	\$54.23/\$50.96
PE1P1	DS-1		\$1.92	\$99.23/\$69.15
PE1P3	DS-3		\$39.94	\$97.48/\$66.90
PE1F2	2-fiber		\$13.28	\$73.00/\$52.00
PE1F4	4-fiber		\$23.87	\$88.00/\$67.00
	Co-Carrier Cross-Connect (Note 5)			
PE1ES Fiber	Fiber Arrangement Cable Support Structure	Per linear foot (existing)	\$0.06	NA
PE1DS Copper	Copper or Coaxial Arrangement	Per linear foot (existing)	\$0.03	NA
TBD	Cable Support Structure Construction	Per new construction	NA	ICB
PE1A1	Security Access System Security system New Access Card Activation Administrative change, existing card Replace lost or stolen card	Per Central Office Per Card Per Card Per Card	\$52.00	\$55.00 \$35.00 \$250.00
TBD	Space Availability Report	Per Central Office Requested	NA	\$550.00
	POT Bay Arrangements Prior to 6/1/99	Per Cross Connect		
PE1PE	2 Wire Cross-Connect		\$0.06	NA
PE1PF	4 Wire Cross-Connect		\$0.15	NA
PE1PG	DS1 Cross-Connect		\$0.58	NA
PE1PH	DS3 Cross-Connect		\$4.51	NA
PE1B2	2 Fiber Cross-Connect		\$32.94	NA
PE1B4	4 Fiber Cross-Connect		\$44.42	NA
	Security Escort			
PE1BT	Basic Time	Per 1/2 hour/Additional	NA	\$56.09/\$31.99
PE1OT	Overtime	Half-hour	NA	\$67.75/\$39.00
PE1PT	Premium Time		NA	\$79.41/\$46.01

EXHIBIT A: BELLSouth/Interprise America RATES - KENTUCKY
PHYSICAL COLLOCATION (cont.)

USOC	Rate Element Description	Unit	Recurring Rate (RC)	Non-Recurring Rate (NRC)
AEH	Additional Engineering Fee (Note 5)	Per request, First half hour/Add'l Half hour		First /Add'l Basic Time - \$31.00/\$22.00 Overtime - \$37.00/\$26.00

Note(s):

N/A refers to rate elements which do not have a negotiated rate.

- (1) **Subsequent Application Fee:** BellSouth requires the submission of an Application Fee for modifications to an existing arrangement. However, when the modifications do not require BellSouth to expend capital, BellSouth will assess the Subsequent Application Fee in lieu of the Application Fee. Proposed modifications that could result in assessment of a Subsequent Application Fee would cause BellSouth to analyze the following but are not limited to: floor loading changes, changes to HVAC requirements, power requirement changes which may result in a power plant upgrade, environmental or safety requirements, or equipment relocation. Should the Subsequent Application Fee not be included as part of this Attachment, Interprise America will be assessed the full Application Fee for all subsequent activity for completed arrangements.
- (2) **Space Preparation Fee:** The Space Preparation Fee is a one-time fee, assessed per arrangement, per location. It recovers the costs associated with the shared physical collocation area within a Central Office, which include survey, engineering, design and modification costs for network, building and support systems. In the event Interprise America opts for non-enclosed space, the space preparation fee will be assessed based on the total floor space dedicated to Interprise America as prescribed in Section 7 of the Collocation Attachment.
- (3) **Space Enclosure Fee:** For cages requested prior to June 1, 1999, the Space Enclosure Construction Fee is a one-time fee, assessed per enclosure, per location with a one-hundred (100) square foot minimum enclosure. It recovers costs associated with providing an optional equipment arrangement enclosure, which include architectural and engineering fees, materials, and installation costs. The cost for additional square feet is applicable only when ordered with the first 100 square feet and must be requested in fifty (50) square foot increments. Interprise America may, at its option, arrange with a BellSouth certified contractor to construct the space enclosure in accordance with BellSouth's guidelines and specifications. In this event, the contractor shall directly bill Interprise America for the space enclosure, and this fee shall not be applicable.
- (4) **Co-Carrier Cross-Connect.** As stated in Section 5 of the Collocation Attachment, Interprise America may connect to other CLECs within the designated Central Office in addition to, and not in lieu of, interconnection to BellSouth services and facilities. Where BellSouth must construct a cable rack structure to house the co-Carrier cross-connection, construction charges will be applied on an individual case basis. BellSouth shall provide an estimate of these charges in the Application Response. Where an existing cable rack structure is in place and has sufficient capacity to accommodate the co-Carrier cross-connection requested, the recurring charges as stated in this Exhibit A shall apply.
- (5) **Additional Engineering Fee:** BellSouth's additional engineering, and other labor costs associated with handling Interprise America-requested modifications to requests in progress or augmentations to existing arrangements shall be recovered as Additional Engineering charges, under provisions in BellSouth's F.C.C. Number 1 Tariff, Sections 13.1 and 13.2. Should Additional Engineering rates not be included, Interprise America agrees not to make changes to collocation arrangement after a Bona Fide Firm Order is submitted.

**EXHIBIT A: BELLSOUTH/Interprise America RATES – LOUISIANA
PHYSICAL COLLOCATION**

Rates marked with an asterisk (*) are interim and are subject to true-up.

USOC	Rate Element Description	Unit	Recurring Rate (RC)	Non-Recurring Rate (NRC)
PE1BA	Application Fee	Per Request	NA	\$4,910.00
PE1CA	Subsequent Application Fee (Note 1)	Per Request	NA	\$1600.00 Minimum
PE1BB	Space Preparation Fee (Note 2)			
	Mechanical / HVAC*	Per ton (one ton minimum)		\$2,400.00
	Ground Bar*	Per Connection		\$720.00
	Project Management*	Per arrangement		\$1,675.00
	Cable Racking/Fiber Duct	Per arrangement, per square foot		ICB
	Frame / Aisle lighting	Per arrangement, per square foot		ICB
	Framework Ground Conductors	Per arrangement		ICB
	Extraordinary Modifications	Per arrangement		ICB
PE1BW PE1CW	Space Enclosure (Note 3) <i>Prior to 6/1/99</i> Welded Wire-mesh Welded Wire-mesh	Per first 100 sq. ft. Per add'l 50 sq. ft.	\$197.55 \$20.07	NA NA
PE1PJ	Floor Space	Per square foot	\$4.01	NA
PE1BD	Cable Installation	Per Cable	NA	\$1,706.00 Disconnect charge \$36.00
PE1PM	Cable Support Structure	Per entrance cable	\$24.05	NA
PE1PL	Power			
	-48V DC Power	Per amp	\$7.15	ICB
	120V AC Power single phase*	Per breaker amp	\$5.50	ICB
	240V AC Power single phase*	Per breaker amp	\$11.00	ICB
	120V AC Power three phase*	Per breaker amp	\$16.50	ICB
	277V AC Power three phase*	Per breaker amp	\$38.20	ICB

**EXHIBIT A: BELLSOUTH/Interprise America RATES - LOUISIANA
PHYSICAL COLLOCATION (cont.)**

Rates marked with an asterisk (*) are interim and are subject to true-up.

USOC	Rate Element Description	Unit	Recurring Rate (RC)	Non-Recurring Rate (NRC)
PE1P2	Cross Connects (Note 4) 2-wire	Per Cross Connect	\$0.26	First / Additional \$23.04/\$22.11
PE1P4	4-wire		\$0.52	\$23.23/\$22.24
PE1P1	DS-1		\$2.03	\$43.61/\$30.60
PE1P3	DS-3		\$36.27	\$41.46/\$29.20
PE1F2	2-fiber		\$10.20	\$73.00/\$52.00
PE1F4	4-fiber		\$18.34	\$88.00/\$67.00
	2-wire			Disconnect charges First / Additional \$9.48/\$8.54
	4-wire			\$9.53/\$8.55
	DS-1			\$9.56/\$8.63
	DS-3			\$11.06/\$8.86
	Co-Carrier Cross-Connect (Note 5)			
PE1ES Fiber	Fiber Arrangement Cable Support Structure	Per linear foot (existing)	\$0.06	NA
PE1DS Copper	Copper or Coaxial Arrangement	Per linear foot (existing)	\$0.03	NA
TBD	Cable Support Structure Construction	Per new construction	NA	ICB
PE1A1	Security Access System Security system*	Per Central Office	\$52.00	
	New Access Card Activation*	Per Card		\$55.00
	Administrative change, existing card*	Per Card		\$35.00
	Replace lost or stolen card	Per Card		\$250.00
TBD	Space Availability Report*	Per Central Office Requested		\$550.00

**EXHIBIT A: BELLSOUTH/!nterprise America RATES - LOUISIANA
PHYSICAL COLLOCATION (cont.)**

Rates marked with an asterisk (*) are interim and are subject to true-up.

USOC	Rate Element Description	Unit	Recurring Rate (RC)	Non-Recurring Rate (NRC)
	POT Bay Arrangements <i>Prior to 6/1/99</i>	Per Cross Connect		
PE1PE	2 Wire Cross-Connect		\$0.0776	NA
PE1PF	4 Wire Cross-Connect		\$0.1552	NA
PE1PG	DS1 Cross-Connect		\$0.6406	NA
PE1PH	DS3 Cross-Connect		\$4.75	NA
PE1B2	2 Fiber Cross-Connect		\$25.30	NA
PE1B4	4 Fiber Cross-Connect		\$34.12	NA
	Security Escort			
PE1BT	Basic Time	Per 1/2	NA	\$32.35/\$19.95
PE1OT	Overtime	hour/Additional	NA	\$40.50/\$25.00
PE1PT	Premium Time	Half-hour	NA	\$48.66/\$30.05
AEH	Additional Engineering Fee (Note 6)	Per request, First half hour/Add'l Half hour		First /Add'l Basic Time - \$31.00/\$22.00 Overtime - \$37.00/\$26.00

Note(s):

N/A refers to rate elements which do not have a negotiated rate.

- (1) **Subsequent Application Fee:** BellSouth requires the submission of an Application Fee for modifications to an existing arrangement. However, when the modifications do not require BellSouth to expend capital, BellSouth will assess the Subsequent Application Fee in lieu of the Application Fee. Proposed modifications that could result in assessment of a Subsequent Application Fee would cause BellSouth to analyze the following but are not limited to: floor loading changes, changes to HVAC requirements, power requirement changes which may result in a power plant upgrade, environmental or safety requirements, or equipment relocation. Should the Subsequent Application Fee not be included as part of this Attachment, !nterprise America will be assessed the full Application Fee for all subsequent activity for completed arrangements.
- (2) **Space Preparation Fee:** The Space Preparation Fee is a one-time fee, assessed per arrangement, per location. It recovers the costs associated with the shared physical collocation area within a Central Office, which include survey, engineering, design and modification costs for network, building and support systems. In the event !nterprise America opts for non-enclosed space, the space preparation fee will be assessed based on the total floor space dedicated to !nterprise America as prescribed in Section 7 of the Collocation Attachment.

EXHIBIT A: BELLSOUTH/Interprise America RATES - LOUISIANA
PHYSICAL COLLOCATION (cont.)

- (3) **Space Enclosure Fee:** For cages requested prior to June 1, 1999, the Space Enclosure Construction Fee is a monthly recurring fee, assessed per enclosure, per location with a one-hundred (100) square foot minimum enclosure. It recovers costs associated with providing an optional equipment arrangement enclosure, which include architectural and engineering fees, materials, and installation costs. The cost for additional square feet is applicable only when ordered with the first 100 square feet and must be requested in fifty (50) square foot increments. Interprise America may, at its option, arrange with a BellSouth certified contractor to construct the space enclosure in accordance with BellSouth's guidelines and specifications. In this event, the contractor shall directly bill Interprise America for the space enclosure, and this fee shall not be applicable.
- (4) **Cross Connects:** The charges for cross connects are for orders placed electronically. Cross connect elements may also be ordered manually for which there is an additional charge per element.

	First / Additional	Disconnect Charges First / Additional
2-wire	\$24.92/\$23.99	\$10.56/\$9.62
4-wire	\$25.11/\$24.12	\$10.61/\$9.63
DS-1	\$45.49/\$32.48	\$10.64/\$9.71
DS-3	\$43.34/\$31.08	\$12.14/\$9.94

- (5) **Co-Carrier Cross-Connect.** As stated in Section 5 of the Collocation Attachment, Interprise America may connect to other CLECs within the designated Central Office in addition to, and not in lieu of, interconnection to BellSouth services and facilities. Where BellSouth must construct a cable rack structure to house the co-Carrier cross-connection, construction charges will be applied on an individual case basis. BellSouth shall provide an estimate of these charges in the Application Response. Where an existing cable rack structure is in place and has sufficient capacity to accommodate the co-Carrier cross-connection requested, the recurring charges as stated in this Exhibit A shall apply.
- (6) **Additional Engineering Fee:** BellSouth's additional engineering, and other labor costs associated with handling Interprise America-requested modifications to requests in progress or augmentations to existing arrangements shall be recovered as Additional Engineering charges, under provisions in BellSouth's F.C.C. Number 1 Tariff, Sections 13.1 and 13.2. Should Additional Engineering rates not be included, Interprise America agrees not to make changes to collocation arrangement after a Bona Fide Firm Order is submitted.

**EXHIBIT A: BELLSOUTH/Enterprise America RATES – MISSISSIPPI
PHYSICAL COLLOCATION**

Rates marked with an asterisk (*) are interim and are subject to true-up.

USOC	Rate Element Description	Unit	Recurring Rate (RC)	Non-Recurring Rate (NRC)
PE1BA	Application Fee	Per Request	NA	\$6,993.00 Disconnect charge \$1.70
PE1CA	Subsequent Application Fee (Note 1)	Per Request	NA	\$1600.00 Minimum
PE1BB	Space Preparation Fee (Note 2)			
	Mechanical / HVAC*	Per ton (one ton minimum)		\$2,400.00
	Ground Bar*	Per Connection		\$720.00
	Project Management*	Per arrangement		\$1,675.00
	Cable Racking/Fiber Duct	Per arrangement, per square foot		ICB
	Frame / Aisle lighting	Per arrangement, per square foot		ICB
	Framework Ground Conductors	Per arrangement		ICB
	Extraordinary Modifications	Per arrangement		ICB
PE1BW PE1CW	Space Enclosure (Note 3) <i>Prior to 6/1/99</i> Welded Wire-mesh Welded Wire-mesh	Per first 100 sq. ft. Per add'l 50 sq. ft.	\$205.08 \$20.83	NA NA
PE1PJ	Floor Space	Per square foot	\$3.45	Disconnect charge \$53.24
PE1BD	Cable Installation	Per Cable	NA	\$2,419.00
PE1PM	Cable Support Structure	Per entrance cable	\$22.90	NA
PE1PL	Power			
	-48V DC Power	Per amp	\$6.93	ICB
	120V AC Power single phase*	Per breaker amp	\$5.50	ICB
	240V AC Power single phase*	Per breaker amp	\$11.00	ICB
	120V AC Power three phase*	Per breaker amp	\$16.50	ICB
	277V AC Power three phase*	Per breaker amp	\$38.20	ICB

**EXHIBIT A: BELLSOUTH/Interprise America RATES - MISSISSIPPI
PHYSICAL COLLOCATION (cont.)**

Rates marked with an asterisk (*) are interim and are subject to true-up.

USOC	Rate Element Description	Unit	Recurring Rate (RC)	Non-Recurring Rate (NRC)
PE1P2	Cross Connects (Note 4) 2-wire	Per Cross Connect	\$3996	First / Additional \$30.93/\$29.59
PE1P4	4-wire		\$7992	\$31.17/\$29.77
PE1P1	DS-1		\$2.90	\$60.42/\$41.68
PE1P3	DS-3		\$53.31	\$57.45/\$39.81
PE1F2	2-fiber		\$15.82	\$73.00/\$52.00
PE1F4	4-fiber		\$28.43	\$88.00/\$67.00
	2-wire			Disconnect Charges First / Additional \$12.76/\$11.43
	4-wire			\$12.83/\$11.43
	DS-1			\$12.87/\$11.54
	DS-3			\$14.92/\$11.80
	Co-Carrier Cross-Connect (Note 5)			
PE1ES Fiber	Fiber Arrangement Cable Support Structure	Per linear foot (existing)	\$0.06	NA
PE1DS Copper	Copper or Coaxial Arrangement	Per linear foot (existing)	\$0.03	NA
TBD	Cable Support Structure Construction	Per new construction	NA	ICB
PE1A1	Security Access System Security system* New Access Card Activation* Administrative change, existing card* Replace lost or stolen card	Per Central Office Per Card Per Card Per Card	\$52.00	\$55.00 \$35.00 \$250.00
TBD	Space Availability Report*	Per Central Office Requested		\$550.00

**EXHIBIT A: BELL SOUTH/Interprise America RATES - MISSISSIPPI
PHYSICAL COLLOCATION (cont.)**

Rates marked with an asterisk (*) are interim and are subject to true-up.

USOC	Rate Element Description	Unit	Recurring Rate (RC)	Non-Recurring Rate (NRC)
	POT Bay Arrangements <i>Prior to 6/1/99</i>	Per Cross Connect		
PE1PE	2 Wire Cross-Connect		\$0.1195	NA
PE1PF	4 Wire Cross-Connect		\$0.2389	NA
PE1PG	DS1 Cross-Connect		\$0.9862	NA
PE1PH	DS3 Cross-Connect		\$5.81	NA
PE1B2	2 Fiber Cross-Connect		\$39.23	NA
PE1B4	4 Fiber Cross-Connect		\$52.91	NA
AEH	Additional Engineering Fee (Note 6)	Per request, First half hour/Add'l Half hour		First /Add'l Basic Time - \$31.00/\$22.00 Overtime - \$37.00/\$26.00
	Security Escort			
PE1BT	Basic Time	Per 1/2	NA	\$42.87/\$25.54
PE1OT	Overtime	hour/Additional	NA	\$54.43/\$32.41
PE1PT	Premium Time	Half-hour	NA	\$65.99/\$39.28

Note(s):

N/A refers to rate elements which do not have a negotiated rate.

- (1) **Subsequent Application Fee:** BellSouth requires the submission of an Application Fee for modifications to an existing arrangement. However, when the modifications do not require BellSouth to expend capital, BellSouth will assess the Subsequent Application Fee in lieu of the Application Fee. Proposed modifications that could result in assessment of a Subsequent Application Fee would cause BellSouth to analyze the following but are not limited to: floor loading changes, changes to HVAC requirements, power requirement changes which may result in a power plant upgrade, environmental or safety requirements, or equipment relocation. Should the Subsequent Application Fee not be included as part of this Attachment, Interprise America will be assessed the full Application Fee for all subsequent activity for completed arrangements.
- (2) **Space Preparation Fee:** The Space Preparation Fee is a one-time fee, assessed per arrangement, per location. It recovers the costs associated with the shared physical collocation area within a Central Office, which include survey, engineering, design and modification costs for network, building and support systems. In the event Interprise America opts for non-enclosed space, the space preparation fee will be assessed based on the total floor space dedicated to Interprise America as prescribed in Section 7 of the Collocation Attachment.

EXHIBIT A: BELLSOUTH/Interprise America RATES - MISSISSIPPI
PHYSICAL COLLOCATION (cont.)

- (3) **Space Enclosure Fee:** For cages requested prior to June 1, 1999, the Space Enclosure Construction Fee is a monthly recurring fee, assessed per enclosure, per location with a one-hundred (100) square foot minimum enclosure. It recovers costs associated with providing an optional equipment arrangement enclosure, which include architectural and engineering fees, materials, and installation costs. The cost for additional square feet is applicable only when ordered with the first 100 square feet and must be requested in fifty (50) square foot increments. Interprise America may, at its option, arrange with a BellSouth certified contractor to construct the space enclosure in accordance with BellSouth's guidelines and specifications. In this event, the contractor shall directly bill Interprise America for the space enclosure, and this fee shall not be applicable.
- (4) **Cross Connects:** The charges for cross connects are for orders placed electronically. Cross connect elements may also be ordered manually for which there is an additional charge per element.

	First / Additional	Disconnect Charges First / Additional
2-wire	\$33.58 / \$32.24	\$14.27 / \$12.94
4-wire	\$33.82 / \$32.42	\$14.34 / \$12.94
DS-1	\$63.07 / \$44.33	\$14.38 / \$13.05
DS-3	\$60.10 / \$42.46	\$16.43 / \$13.31

- (5) **Co-Carrier Cross-Connect.** As stated in Section 5 of the Collocation Attachment, Interprise America may connect to other CLECs within the designated Central Office in addition to, and not in lieu of, interconnection to BellSouth services and facilities. Where BellSouth must construct a cable rack structure to house the co-Carrier cross-connection, construction charges will be applied on an individual case basis. BellSouth shall provide an estimate of these charges in the Application Response. Where an existing cable rack structure is in place and has sufficient capacity to accommodate the co-Carrier cross-connection requested, the recurring charges as stated in this Exhibit A shall apply.
- (6) **Additional Engineering Fee:** BellSouth's additional engineering, and other labor costs associated with handling Interprise America-requested modifications to requests in progress or augmentations for existing arrangements shall be recovered as Additional Engineering charges, under provisions in BellSouth's F.C.C. Number 1 Tariff, Sections 13.1 and 13.2. Should Additional Engineering rates not be included, Interprise America agrees not to make changes to collocation arrangement after a Bona Fide Firm Order is submitted.

EXHIBIT A: BELLSOUTH/Interprise America RATES – NORTH CAROLINA*
PHYSICAL COLLOCATION

*Rates are interim and subject to true-up.

USOC	Rate Element Description	Unit	Recurring Rate (RC)	Non-Recurring Rate (NRC)
PE1BA	Application Fee	Per Request	NA	\$3,850.00
PE1CA	Subsequent Application Fee (Note 1)	Per Request	NA	\$1,600.00 Minimum
PE1BB	Space Preparation Fee (Note 2)			
	Mechanical / HVAC	Per ton (one ton minimum)		\$2,400.00
	Ground Bar	Per Connection		\$720.00
	Project Management	Per arrangement		\$1,675.00
	Cable Racking/Fiber Duct	Per arrangement, per square foot		ICB
	Frame / Aisle lighting	Per arrangement, per square foot		ICB
	Framework Ground Conductors	Per arrangement		ICB
	Extraordinary Modifications	Per arrangement		ICB
PE1BW PE1CW	Space Enclosure (Note 3) <i>Prior to 6/1/99</i> Welded Wire-mesh Welded Wire-mesh	Per first 100 sq. ft. Per add'l 50 sq. ft.	\$146.80 \$14.91	NA NA
PE1PJ	Floor Space	Per square foot	\$7.50	NA
PE1BD	Cable Installation	Per Cable	NA	\$2,750.00
PE1PM	Cable Support Structure	Per entrance cable	\$13.35	NA
PE1PL	Power			
	-48V DC Power	Per amp	\$5.00	ICB
	120V AC Power single phase	Per breaker amp	\$5.50	ICB
	240V AC Power single phase	Per breaker amp	\$11.00	ICB
	120V AC Power three phase	Per breaker amp	\$16.50	ICB
	277V AC Power three phase	Per breaker amp	\$38.20	ICB

EXHIBIT A: BELLSOUTH/Interprise America RATES – NORTH CAROLINA*
PHYSICAL COLLOCATION (cont.)

*Rates are interim and subject to true-up.

USOC	Rate Element Description	Unit	Recurring Rate (RC)	Non-Recurring Rate (NRC)
PE1P2	Cross Connects 2-wire	Per Cross Connect	\$.30	First / Additional \$19.20/\$19.20
PE1P4	4-wire		\$.50	\$19.20/\$19.20
PE1P1	DS-1		\$8.00	\$155.00/\$27.00
PE1P3	DS-3		\$72.00	\$155.00/\$27.00
PE1F2	2-fiber		\$15.90	\$73.00/\$52.00
PE1F4	4-fiber		\$28.50	\$88.00/\$67.00
	Co-Carrier Cross-Connect (Note 4)			
PE1ES Fiber	Fiber Arrangement Cable Support Structure	Per linear foot (existing)	\$0.06	NA
PE1DS Copper	Copper or Coaxial Arrangement	Per linear foot (existing)	\$0.03	NA
TBD	Cable Support Structure Construction	Per new construction	NA	ICB
PE1A1	Security Access System Security system New Access Card Activation Administrative change, existing card Replace lost or stolen card	Per Central Office Per Card Per Card Per Card	\$52.00	\$55.00 \$35.00 \$250.00
TBD	Space Availability Report	Per Central Office Requested		\$550.00
	POT Bay Arrangements <i>Prior to 6/1/99</i>	Per Cross Connect		
PE1PE	2 Wire Cross-Connect		\$0.40	NA
PE1PF	4 Wire Cross-Connect		\$1.20	NA
PE1PG	DS1 Cross-Connect		\$1.20	NA
PE1PH	DS3 Cross-Connect		\$8.00	NA
PE1B2	2 Fiber Cross-Connect		\$39.30	NA
PE1B4	4 Fiber Cross-Connect		\$53.00	NA
PE1BT	Security Escort Basic Time	Per 1/2 hour	NA	\$41.00/\$25.00
PE1OT	Overtime	hour/Additional	NA	\$48.00/\$30.00
PE1PT	Premium Time	Half-hour	NA	\$55.00/\$35.00

**EXHIBIT A: BELLSOUTH/Interprise America RATES – NORTH CAROLINA
PHYSICAL COLLOCATION (cont.)**

USOC	Rate Element Description	Unit	Recurring Rate (RC)	Non-Recurring Rate (NRC)
AEH	Additional Engineering Fee (Note 5)	Per request, First half hour/Add'l Half hour		First /Add'l Basic Time - \$31.00/\$22.00 Overtime - \$37.00/\$26.00

Note(s):

N/A refers to rate elements which do not have a negotiated rate.

- (1) **Subsequent Application Fee:** BellSouth requires the submission of an Application Fee for modifications to an existing arrangement. However, when the modifications do not require BellSouth to expend capital, BellSouth will assess the Subsequent Application Fee in lieu of the Application Fee. Proposed modifications that could result in assessment of a Subsequent Application Fee would cause BellSouth to analyze the following but are not limited to: floor loading changes, changes to HVAC requirements, power requirement changes which may result in a power plant upgrade, environmental or safety requirements, or equipment relocation. Should the Subsequent Application Fee not be included as part of this Attachment, Interprise America will be assessed the full Application Fee for all subsequent activity for completed arrangements.
- (2) **Space Preparation Fee:** The Space Preparation Fee is a one-time fee, assessed per arrangement, per location. It recovers the costs associated with the shared physical collocation area within a Central Office, which include survey, engineering, design and modification costs for network, building and support systems. In the event Interprise America opts for non-enclosed space, the space preparation fee will be assessed based on the total floor space dedicated to Interprise America as prescribed in Section 7 of the Collocation Attachment.
- (3) **Space Enclosure Fee:** For cages requested prior to June 1, 1999, the Space Enclosure Construction Fee is a monthly recurring fee, assessed per enclosure, per location with a one-hundred (100) square foot minimum enclosure. It recovers costs associated with providing an optional equipment arrangement enclosure, which include architectural and engineering fees, materials, and installation costs. The cost for additional square feet is applicable only when ordered with the first 100 square feet and must be requested in fifty (50) square foot increments. Interprise America may, at its option, arrange with a BellSouth certified contractor to construct the space enclosure in accordance with BellSouth's guidelines and specifications. In this event, the contractor shall directly bill Interprise America for the space enclosure, and this fee shall not be applicable.
- (4) **Co-Carrier Cross-Connect.** As stated in Section 5 of the Collocation Attachment, Interprise America may connect to other CLECs within the designated Central Office in addition to, and not in lieu of, interconnection to BellSouth services and facilities. Where BellSouth must construct a cable rack structure to house the co-Carrier cross-connection, construction charges will be applied on an individual case basis. BellSouth shall provide an estimate of these charges in the Application Response. Where an existing cable rack structure is in place and has sufficient capacity to accommodate the co-Carrier cross-connection requested, the recurring charges as stated in this Exhibit A shall apply.
- (5) **Additional Engineering Fee:** BellSouth's additional engineering, and other labor costs associated with handling Interprise America-requested modifications to requests in progress or augmentations for existing arrangements shall be recovered as Additional Engineering charges, under provisions in BellSouth's F.C.C. Number 1 Tariff, Sections 13.1 and 13.2. Should Additional Engineering rates not be included, Interprise America agrees not to make changes to collocation arrangement after a Bona Fide Firm Order is submitted.

**EXHIBIT A: BELLSOUTH/Interprise America RATES – SOUTH CAROLINA
PHYSICAL COLLOCATION**

Rates marked with an asterisk (*) are interim and are subject to true-up.

USOC	Rate Element Description	Unit	Recurring Rate (RC)	Non-Recurring Rate (NRC)
PE1BA	Application Fee	Per Request	NA	\$4,850.00
PE1CA	Subsequent Application Fee (Note 1)	Per Request	NA	\$1600.00 Minimum
PE1BB	Space Preparation Fee (Note 2)			
	Mechanical / HVAC*	Per ton (one ton minimum)		\$2,400.00
	Ground Bar*	Per Connection		\$720.00
	Project Management*	Per arrangement		\$1,675.00
	Cable Racking/Fiber Duct	Per arrangement, per square foot		ICB
	Frame / Aisle lighting	Per arrangement, per square foot		ICB
	Framework Ground Conductors	Per arrangement		ICB
	Extraordinary Modifications			ICB
PE1BW PE1CW	Space Enclosure (Note 3) <i>Prior to 6/1/99</i> Welded Wire-mesh Welded Wire-mesh	Per first 100 sq. ft. Per add'l 50 sq. ft.	\$224.60 \$22.81	NA NA
PE1PJ	Floor Space	Per square foot	\$3.90	NA
PE1BD	Cable Installation	Per Cable	NA	\$2,217.00
PE1PM	Cable Support Structure	Per entrance cable	\$24.55	NA
PE1PL	Power			
	-48V DC Power	Per amp	\$7.09	ICB
	120V AC Power single phase*	Per breaker amp	\$5.50	ICB
	240V AC Power single phase*	Per breaker amp	\$11.00	ICB
	120V AC Power three phase*	Per breaker amp	\$16.50	ICB
	277V AC Power three phase*	Per breaker amp	\$38.20	ICB

**EXHIBIT A: BELLSOUTH/Interprise America RATES – SOUTH CAROLINA
PHYSICAL COLLOCATION (cont.)**

USOC	Rate Element Description	Unit	Recurring Rate (RC)	Non-Recurring Rate (NRC)
	Cross Connects (Note 4)			First / Additional
PE1P2	2-wire	Per Cross Connect	\$.3648	\$41.50/\$38.94
PE1P4	4-wire	Per Cross Connect	\$.7297	\$41.56/\$38.90
PE1P1	DS-1	Per Cross Connect	\$2.70	\$70.79/\$50.78
PE1P3	DS-3	Per Cross Connect	\$49.24	\$69.60/\$49.14
PE1F2	2-fiber	Per Cross Connect	\$13.75	\$73.00/\$52.00
PE1F4	4-fiber	Per Cross Connect	\$24.71	\$88.00/\$67.00
	Co-Carrier Cross-Connect (Note 5)			
PE1ES Fiber	Fiber Arrangement Cable Support Structure	Per linear foot (existing)	\$0.06	NA
PE1DS Copper	Copper or Coaxial Arrangement	Per linear foot (existing)	\$0.03	NA
TBD	Cable Support Structure Construction	Per new construction	NA	ICB
PE1A1	Security Access System Security system* New Access Card Activation* Administrative change, existing card* Replace lost or stolen card	Per Central Office Per Card Per Card Per Card	\$52.00	\$55.00 \$35.00 \$250.00
TBD	Space Availability Report*	Per Central Office Requested		\$550.00
	POT Bay Arrangements Prior to 6/1/99	Per Cross Connect		
PE1PE	2 Wire Cross-Connect		\$.1091	NA
PE1PF	4 Wire Cross-Connect		\$.2181	NA
PE1PG	DS1 Cross-Connect		\$.9004	NA
PE1PH	DS3 Cross-Connect		\$5.64	NA
PE1B2	2 Fiber Cross-Connect		\$34.09	NA
PE1B4	4 Fiber Cross-Connect		\$45.97	NA
	Security Escort			
PE1BT	Basic Time	Per 1/2 hour	NA	\$43.00/\$25.57
PE1OT	Overtime	hour/Additional	NA	\$54.62/\$32.46
PE1PT	Premium Time	Half-hour	NA	\$66.24/\$39.35

**EXHIBIT A: BELLSOUTH/Interprise America RATES – SOUTH CAROLINA
PHYSICAL COLLOCATION (cont.)**

AEH	Additional Engineering Fee (Note 6)	Per request, First half hour/Add'l Half hour		First /Add'l Basic Time - \$31.00/\$22.00 Overtime - \$37.00/\$26.00

Note(s):

N/A refers to rate elements which do not have a negotiated rate.

- (1) **Subsequent Application Fee:** BellSouth requires the submission of an Application Fee for modifications to an existing arrangement. However, when the modifications do not require BellSouth to expend capital, BellSouth will assess the Subsequent Application Fee in lieu of the Application Fee. Proposed modifications that could result in assessment of a Subsequent Application Fee would cause BellSouth to analyze the following but are not limited to: floor loading changes, changes to HVAC requirements, power requirement changes which may result in a power plant upgrade, environmental or safety requirements, or equipment relocation. Should the Subsequent Application Fee not be included as part of this Attachment, Interprise America will be assessed the full Application Fee for all subsequent activity for completed arrangements.
- (2) **Space Preparation Fee:** The Space Preparation Fee is a one-time fee, assessed per arrangement, per location. It recovers the costs associated with the shared physical collocation area within a Central Office, which include survey, engineering, design and modification costs for network, building and support systems. In the event Interprise America opts for non-enclosed space, the space preparation fee will be assessed based on the total floor space dedicated to Interprise America as prescribed in Section 7 of the Collocation Attachment.
- (3) **Space Enclosure Fee:** For cages requested prior to June 1, 1999, the Space Enclosure Construction Fee is a monthly recurring fee, assessed per enclosure, per location with a one-hundred (100) square foot minimum enclosure. It recovers costs associated with providing an optional equipment arrangement enclosure, which include architectural and engineering fees, materials, and installation costs. The cost for additional square feet is applicable only when ordered with the first 100 square feet and must be requested in fifty (50) square foot increments. Interprise America may, at its option, arrange with a BellSouth certified contractor to construct the space enclosure in accordance with BellSouth's guidelines and specifications. In this event, the contractor shall directly bill Interprise America for the space enclosure, and this fee shall not be applicable.
- (4) **Cross Connects:** The charges for cross connects are for orders placed electronically. Cross connect elements may also be ordered manually for which there is an additional charge per element.

	<u>First / Additional</u>
2-wire	\$46.66 / \$44.10
4-wire	\$46.68 / \$44.02
DS-1	\$75.88 / \$55.87
DS-3	\$74.69 / \$54.23

- (5) **Co-Carrier Cross-Connect.** As stated in Section 5 of the Collocation Attachment, Interprise America may connect to other CLECs within the designated Central Office in addition to, and not in lieu of, interconnection to BellSouth services and facilities. Where BellSouth must construct a cable rack structure to house the co-Carrier cross-connection, construction charges will be applied on an individual case basis. BellSouth shall provide an estimate of these charges in the Application Response. Where an existing cable rack structure is in place and has sufficient capacity to accommodate the co-Carrier cross-connection requested, the recurring charges as stated in this Exhibit A shall apply.

**EXHIBIT A: BELLSOUTH/Interprise America RATES – SOUTH CAROLINA
PHYSICAL COLLOCATION (cont.)**

- (6) **Additional Engineering Fee:** BellSouth's additional engineering, and other labor costs associated with handling Interprise America-requested modifications to requests in progress or augmentations to existing arrangements shall be recovered as Additional Engineering charges, under provisions in BellSouth's F.C.C. Number 1 Tariff, Sections 13.1 and 13.2. Should Additional Engineering rates not be included, Interprise America agrees not to make changes to collocation arrangement after a Bona Fide Firm Order is submitted.

EXHIBIT A: BELLSOUTH/Interprise America RATES – TENNESSEE*
PHYSICAL COLLOCATION

*All Rates are interim and subject to true-up.

USOC	Rate Element Description	Unit	Recurring Rate (RC)	Non-Recurring Rate (NRC)
PE1BA	Application Fee	Per Request	NA	\$3,850.00
PE1CA	Subsequent Application Fee (Note 1)	Per Request	NA	\$1,600.00 Minumum
PE1BB	Space Preparation Fee (Note 2)			
	Mechanical / HVAC	Per ton (one ton minimum)		\$2,400.00
	Ground Bar	Per Connection		\$720.00
	Project Management	Per arrangement		\$1,675.00
	Cable Racking/Fiber Duct	Per arrangement, per square foot		ICB
	Frame / Aisle lighting	Per arrangement, per square foot		ICB
	Framework Ground Conductors	Per arrangement		ICB
	Extraordinary Modifications	Per arrangement		ICB
PE1BW PE1CW	Space Enclosure (Note 3) <i>Prior to 6/1/99</i>			
	Welded Wire-mesh	Per first 100 sq. ft.	\$190.79	NA
	Welded Wire-mesh	Per add'l 50 sq. ft.	\$19.38	NA
PE1PJ	Floor Space	Per square foot	\$7.50	NA
PE1BD	Cable Installation	Per Cable	NA	\$2,750.00
PE1PM	Cable Support Structure	Per entrance cable	\$13.35	NA
PE1PL	Power			
	-48V DC Power	Per amp	\$5.00	ICB
	120V AC Power single phase	Per breaker amp	\$5.50	ICB
	240V AC Power single phase	Per breaker amp	\$11.00	ICB
	120V AC Power three phase	Per breaker amp	\$16.50	ICB
	277V AC Power three phase	Per breaker amp	\$38.20	ICB

EXHIBIT A: BELLSOUTH/Interprise America RATES – TENNESSEE*
PHYSICAL COLLOCATION (cont.)

*Rates are interim and subject to true-up.

USOC	Rate Element Description	Unit	Recurring Rate (RC)	Non-Recurring Rate (NRC)
PE1P2	Cross Connects 2-wire	Per Cross Connect	\$.30	First / Additional \$19.20/\$19.20
PE1P4	4-wire		\$.50	\$19.20/\$19.20
PE1P1	DS-1		\$8.00	\$155.00/\$27.00
PE1P3	DS-3		\$72.00	\$155.00/\$27.00
PE1F2	2-fiber		\$15.90	\$73.00/\$52.00
PE1F4	4-fiber		\$28.50	\$88.00/\$67.00
	Co-Carrier Cross-Connect (Note 4)			
PE1ES Fiber	Fiber cable support structure, existing	Per linear foot	\$0.06	NA
PE1DS Copper	Copper or Coaxial cable support structure, existing	Per linear foot	\$0.03	NA
TBD	Cable Support Structure Construction (new)	Per new construction	NA	ICB
PE1A1	Security Access System Security system New Access Card Activation Administrative change, existing card Replace lost or stolen card	Per Central Office Per Card Per Card Per Card	\$52.00	\$55.00 \$35.00 \$250.00
TBD	Space Availability Report	Per Central Office Requested		\$550.00
	POT Bay Arrangements Prior to 6/1/99			
PE1PE	2 Wire Cross-Connect	Per Cross Connect	\$0.40	NA
PE1PF	4 Wire Cross-Connect	Per Cross Connect	\$1.20	NA
PE1PG	DS1 Cross-Connect	Per Cross Connect	\$1.20	NA
PE1PH	DS3 Cross-Connect	Per Cross Connect	\$8.00	NA
PE1B2	2 Fiber Cross-Connect	Per Cross Connect	\$39.30	NA
PE1B4	4 Fiber Cross-Connect	Per Cross Connect	\$53.00	NA

EXHIBIT A: BELLSOUTH/Interprise America RATES – TENNESSEE*
PHYSICAL COLLOCATION (cont.)

*Rates are interim and subject to true-up.

USOC	Rate Element Description	Unit	Recurring Rate (RC)	Non-Recurring Rate (NRC)
PE1BT PE1OT PE1PT	Security Escort Basic Time Overtime Premium Time	Per 1/2 hour/Additional Half-hour	NA NA NA	\$41.00/\$25.00 \$48.00/\$30.00 \$55.00/\$35.00
AEH	Additional Engineering Fee (Note 5)	Per request, First half hour/Add'l Half hour		First /Add'l Basic Time - \$31.00/\$22.00 Overtime - \$37.00/\$26.00

Note(s):

N/A refers to rate elements which do not have a negotiated rate.

- (1) **Subsequent Application Fee:** BellSouth requires the submission of an Application Fee for modifications to an existing arrangement. However, when the modifications do not require BellSouth to expend capital, BellSouth will assess the Subsequent Application Fee in lieu of the Application Fee. Proposed modifications that could result in assessment of a Subsequent Application Fee would cause BellSouth to analyze the following but are not limited to: floor loading changes, changes to HVAC requirements, power requirement changes which may result in a power plant upgrade, environmental or safety requirements, or equipment relocation. Should the Subsequent Application Fee not be included as part of this Attachment, Interprise America will be assessed the full Application Fee for all subsequent activity for completed arrangements.
- (2) **Space Preparation Fee:** The Space Preparation Fee is a one-time fee, assessed per arrangement, per location. It recovers the costs associated with the shared physical collocation area within a Central Office, which include survey, engineering, design and modification costs for network, building and support systems. In the event Interprise America opts for non-enclosed space, the space preparation fee will be assessed based on the total floor space dedicated to Interprise America as prescribed in Section 7 of the Collocation Attachment.
- (3) **Space Enclosure Fee:** For cages requested prior to June 1, 1999, the Space Enclosure Construction Fee is a monthly recurring fee, assessed per enclosure, per location with a one-hundred (100) square foot minimum enclosure. It recovers costs associated with providing an optional equipment arrangement enclosure, which include architectural and engineering fees, materials, and installation costs. The cost for additional square feet is applicable only when ordered with the first 100 square feet and must be requested in fifty (50) square foot increments. Interprise America may, at its option, arrange with a BellSouth certified contractor to construct the space enclosure in accordance with BellSouth's guidelines and specifications. In this event, the contractor shall directly bill Interprise America for the space enclosure, and this fee shall not be applicable.

EXHIBIT A: BELLSOUTH/Interprise America RATES – TENNESSEE*
PHYSICAL COLLOCATION (cont.)

- (4) **Co-Carrier Cross-Connect.** As stated in Section 5 of the Collocation Attachment, Interprise America may connect to other CLECs within the designated Central Office in addition to, and not in lieu of, interconnection to BellSouth services and facilities. Where BellSouth must construct a cable rack structure to house the co-Carrier cross-connection, construction charges will be applied on an individual case basis. BellSouth shall provide an estimate of these charges in the Application Response. Where an existing cable rack structure is in place and has sufficient capacity to accommodate the co-Carrier cross-connection requested, the recurring charges as stated in this Exhibit A shall apply.
- (5) **Additional Engineering Fee:** BellSouth's additional engineering, and other labor costs associated with handling Interprise America-requested modifications to requests in progress or augmentations for existing arrangements shall be recovered as Additional Engineering charges, under provisions in BellSouth's F.C.C. Number 1 Tariff, Sections 13.1 and 13.2. Should Additional Engineering rates not be included, Interprise America agrees not to make changes to collocation arrangement after a Bona Fide Firm Order is submitted.

ENVIRONMENTAL AND SAFETY PRINCIPLES

The following principles provide basic guidance on environmental and safety issues when applying for and establishing Physical Collocation arrangements.

1. GENERAL PRINCIPLES

1.1 Compliance with Applicable Law. BellSouth and Interprise America agree to comply with applicable federal, state, and local environmental and safety laws and regulations including U.S. Environmental Protection Agency (USEPA) regulations issued under the Clean Air Act (CAA), Clean Water Act (CWA), Resource Conservation and Recovery Act (RCRA), Comprehensive Environmental Response, Compensation and Liability Act (CERCLA), Superfund Amendments and Reauthorization Act (SARA), the Toxic Substances Control Act (TSCA), and OSHA regulations issued under the Occupational Safety and Health Act of 1970, as amended and NFPA and National Electrical Codes (NEC) and the NESC ("Applicable Laws"). Each party shall notify the other if compliance inspections are conducted by regulatory agencies and/or citations are issued that relate to any aspect of this agreement.

1.2 Notice. BellSouth and Interprise America shall provide notice to the other, including Material Safety Data Sheets (MSDSs), of known and recognized physical hazards or Hazardous Chemicals existing on site or brought on site. Each party is required to provide specific notice for known potential Imminent Danger conditions. Interprise America should contact 1-800-743-6737 for BellSouth MSDS sheets.

1.3 Practices/Procedures. BellSouth may make available additional environmental control procedures for Interprise America to follow when working at a BellSouth Premises (See Section 2, below). These practices/procedures will represent the regular work practices required to be followed by the employees and contractors of BellSouth for environmental protection. Interprise America will require its contractors, agents and others accessing the BellSouth Premises to comply with these practices. Section 2 lists the Environmental categories where BST practices should be followed by CLEC when operating in the BellSouth Premises.

1.4 Environmental and Safety Inspections. BellSouth reserves the right to inspect the Interprise America space with proper notification. BellSouth reserves the right to stop any Interprise America work operation that imposes Imminent Danger to the environment, employees or other persons in the area or Facility.

1.5 Hazardous Materials Brought On Site. Any hazardous materials brought into, used, stored or abandoned at the BellSouth Premises by Interprise America are owned by Interprise America. Interprise America will indemnify BellSouth for claims, lawsuits or damages to persons or property caused by these materials. Without prior written BellSouth approval, no substantial new safety or environmental hazards can be created by Interprise America or different hazardous materials used by Interprise America at BellSouth Facility. Interprise America must demonstrate adequate emergency response capabilities for its materials used or

remaining at the BellSouth Facility.

EXHIBIT B

1.6 Spills and Releases. When contamination is discovered at a BellSouth Premises, the party discovering the condition must notify BellSouth. All Spills or Releases of regulated materials will immediately be reported by Interprise America to BellSouth.

1.7 Coordinated Environmental Plans and Permits. BellSouth and Interprise America will coordinate plans, permits or information required to be submitted to government agencies, such as emergency response plans, spill prevention control and countermeasures (SPCC) plans and community reporting. If fees are associated with filing, BellSouth and Interprise America will develop a cost sharing procedure. If BellSouth's permit or EPA identification number must be used, Interprise America must comply with all of BellSouth's permit conditions and environmental processes, including environmental "best management practices (BMP)" (see Section 2, below) and/or selection of BST disposition vendors and disposal sites.

1.8 Environmental and Safety Indemnification. BellSouth and Interprise America shall indemnify, defend and hold harmless the other party from and against any claims (including, without limitation, third-party claims for personal injury or death or real or personal property damage), judgments, damages, (including direct and indirect damages, and punitive damages), penalties, fines, forfeitures, costs, liabilities, interest and losses arising in connection with the violation or alleged violation of any Applicable Law or contractual obligation or the presence or alleged presence of contamination arising out of the acts or omissions of the indemnifying party, its agents, contractors, or employees concerning its operations at the Facility.

2. CATEGORIES FOR CONSIDERATION OF ENVIRONMENTAL ISSUES

When performing functions that fall under the following Environmental categories on BellSouth's Premises, Interprise America agrees to comply with the applicable sections of the current issue of BellSouth's Environmental and Safety Methods and Procedures (M&Ps), incorporated herein by this reference. Interprise America further agrees to cooperate with BellSouth to ensure that Interprise America's employees, agents, and/or subcontractors are knowledgeable of and satisfy those provisions of BellSouth's Environmental M&Ps which apply to the specific Environmental function being performed by Interprise America, its employees, agents and/or subcontractors.

The most current version of reference documentation must be requested from BellSouth.

2. Categories for Consideration of Environmental Issues (cont.)

ENVIRONMENTAL CATEGORIES	ENVIRONMENTAL ISSUES	ADDRESSED BY THE FOLLOWING DOCUMENTATION
Disposal of hazardous material or other regulated material (e.g., batteries, fluorescent tubes, solvents & cleaning materials)	Pollution liability insurance EVET approval of contractor	Std T&C 450 GU-BTEN-001BT, Chapter 4 Std T&C 660-3 GU-BTEN-001BT, Chapter 10
Emergency response	Hazmat/waste release/spill firesafety emergency	GU-BTEN-001BT, Chapter Building Emergency Operations Plan (EOP) (specific to Premises)
Contract labor/outsourcing for services with environmental implications to be performed on BellSouth Premises (e.g., disposition of hazardous material/waste; maintenance of storage tanks)	Performance of services in accordance with BST's environmental M&Ps Insurance	Std T&C 450 Std T&C 450-B (Contact E/S or your DEC/LDEC for copy of appropriate E/S M&Ps.) Std T&C 660
Transportation of hazardous material	Pollution liability insurance EVET approval of contractor	Std T&C 450 GU-BTEN-001BT, Chapter 4 Std T&C 660-3 GU-BTEN-001BT, Chapter 10
Maintenance/operations work which may produce a waste Other maintenance work	Protection of BST employees and equipment	Std T&C 450 GU-BTEN-001BT, Chapter 10 29CFR 1910.147 29CFR 1910 Subpart O

<p>Janitorial services</p>	<p>All waste removal and disposal must conform to all applicable federal, state and local regulations</p> <p>All HazMat & Waste Asbestos notification protection of BST employees and equipment</p>	<p>P&SM Manager - Procurement GU-BTEN-001BT, Chapter 4, GU-BTEN-001BT, Chapter 3 BSP 010-170-001BS (Hazcom)</p>
<p>Manhole cleaning</p>	<p>Pollution liability insurance</p> <p>Manhole entry requirements</p> <p>EVET approval of contractor</p>	<p>Std T&C 450 Std T&C 660-3 BSP 620-145-011PR Issue A, August 1996 GU-BTEN-001BT, Chapter 10 RL9706008BT</p>
<p>Removing or disturbing building materials that may contain asbestos</p>	<p>Asbestos work practices</p>	<p>GU-BTEN-001BT, Chapter 3</p>

3. **DEFINITIONS**

Generator. Under RCRA, the person whose act produces a Hazardous Waste, as defined in 40 CFR 261, or whose act first causes a Hazardous Waste to become subject to regulation. The Generator is legally responsible for the proper management and disposal of Hazardous Wastes in accordance with regulations.

Hazardous Chemical. As defined in the U.S. Occupational Safety and Health (OSHA) hazard communication standard (29 CFR 1910.1200), any chemical which is a health hazard or physical hazard.

Hazardous Waste. As defined in section 1004 of RCRA.

Imminent Danger. Any conditions or practices at a facility which are such that a danger exists which could reasonably be expected to cause immediate death or serious harm to people or immediate significant damage to the environment or natural resources.

Spill or Release. As defined in Section 101 of CERCLA.

4. **ACRONYMS**

DEC/LDEC - Department Environmental Coordinator/Local Department Environmental Coordinator

GU-BTEN-001BT - BellSouth Environmental Methods and Procedures

EVET - Environmental Vendor Evaluation Team

P&SM - Property & Services Management

Std. T&C - Standard Terms & Conditions

NESC - National Electrical Safety Codes

**Amendment to Master Interconnection Agreement
by and between BellSouth Telecommunications, Inc.
and U S WEST Interprise America, Inc. dated September 15, 1997**

This Agreement refers to the Interconnection Agreement (“the Agreement”) entered into by U S WEST Interprise America, Inc. d/b/a Interprise America (“U S WEST”) and BellSouth Telecommunications, Inc. (“BellSouth”) for the state of Kentucky on September 15, 1997. This Amendment (“Amendment”) is made by and between U S WEST and BellSouth and shall be deemed effective on the date executed by U S WEST and BellSouth.

NOW THEREFORE, in consideration of the mutual provisions contained herein and other good and valuable consideration, the receipt and sufficiency of which are hereby acknowledged, U S WEST and BellSouth (individually, a “Party” and collectively, the “Parties”) hereby covenant and agree as follows:

1. Section 41 of Part IV of the General Terms and Conditions Section of the Agreement is hereby renamed from **Electronic Interfaces** to **Operation Support Systems (OSS) Rates** and the language therein is replaced in its entirety with the following language:

41. Operation Support Systems (OSS) Rates

The costs associated with implementing the OSS electronic interfaces should be shared equitably among all parties who benefit from those interfaces. Charges for use of Operational Support Systems (OSS) for Resale shall be set forth in the table below. Charges for use of OSS for Local Interconnection are as set forth in Table 1.

Operational Support Systems (OSS) Rates	Electronic per LSR received from the CLEC by one of the OSS interactive interfaces	Manual per LSR received from the CLEC by means other than one of the OSS interactive interfaces
OSS Order Charge	\$3.50	\$19.99

In addition to the OSS charges, applicable discounted service order and related charges apply per the tariff.

2. Table 1 of the Agreement is hereby amended to include the following OSS rates for Local Interconnection:

OPERATIONAL SUPPORT SYSTEMS	AL
OSS Order charge, per LSR received from the CLEC by one of the OSS interactive interfaces	\$3.50
Incremental charge per LSR received from the CLEC by means other than one of the OSS interactive interfaces	See applicable rate element.

3. U S WEST will incur the mechanized rate for all LSRs, both electronic and manual, if the percentage of mechanized LSRs to total LSRs exceeds the threshold percentages shown below:

Year	Ratio: Mechanized/Total LSRs
1999	70%
2000	80%
2001	90%

The threshold plan will be discontinued in 2002.

4. The Parties agree that the threshold plan described in Paragraph 3 above may be superceded by an LSR specific process that would apply the mechanized LSR rate to only those manual LSRs, which cannot be submitted over an electronic system.

5. The Parties agree that all other provisions of the Agreement, dated September 15, 1997, shall remain in full force and effect.

6. The Parties further agree that either or both of the Parties is authorized to submit this Amendment to the Public Service Commission or other regulatory body having jurisdiction over the subject matter of this Amendment, for approval subject to Section 252(e) of the federal Telecommunications Act of 1996.

IN WITNESS WHEREOF, the parties hereto have caused this Amendment to be executed by their respective duly authorized representatives on the date indicated below.

U S WEST !nterprise America, Inc.
d/b/a !nterprise America

BellSouth Telecommunications, Inc.

Signature on File
Signature

Signature on File
Signature

Mary F. LaFave
Name

Jerry D. Hendrix
Name

Director – Regulatory Affairs
Title

Senior Director
Title

October 5, 1999
Date

October 7, 1999
Date