

**Amendment to the Agreement
Between
PBT Communications, Inc.
and
BellSouth Telecommunications, Inc.
Dated March 19, 2003**

Pursuant to this Amendment, (the "Amendment"), PBT Communications, Inc. ("PBT"), and BellSouth Telecommunications, Inc. ("BellSouth"), hereinafter referred to collectively as the "Parties," hereby agree to amend that certain Interconnection Agreement between the Parties dated March 19, 2003 ("Agreement") to be effective thirty (30) calendar days after the date of the last signature executing the Amendment.

WHEREAS, BellSouth and PBT entered into the Agreement on March 19, 2003, and;

NOW THEREFORE, in consideration of the mutual provisions contained herein and other good and valuable consideration, the receipt and sufficiency of which are hereby acknowledged, the Parties hereby covenant and agree as follows:

1. PBT Adoption of Level 3 Attachment 3, Level 3 Attachment 3 Network Interconnection, and Level 3 Attachment 3 Amendment dated June 7, 2002 are hereby deleted and replaced by the terms and conditions in Exhibit 1 to this Amendment, incorporated herein by reference.
2. Attachment 3 Network Interconnection Rates and Level 3 Attachment 3 Amendment rates dated June 7, 2002 are hereby deleted and replaced by the rates in Exhibit 2 to this Amendment, incorporated herein by reference.
3. For purposes of determining the Expiration Date of this Amendment pursuant to section 2.1 of the Agreement, the Expiration Date shall be March 18, 2006.
4. All of the other provisions of the Agreement, dated March 19, 2003, shall remain in full force and effect.
5. Either or both of the Parties are authorized to submit this Amendment to the respective state regulatory authorities for approval subject to Section 252(e) of the Federal Telecommunications Act of 1996.

Signature Page

IN WITNESS WHEREOF, the Parties have executed this Agreement the day and year written below.

BellSouth Telecommunications, Inc.

By:

Name:

Title:

Date:

Kristen E Rowe

Director

2/26/04

PBT Communications, Inc.

By:

Name:

Title:

Date:

L. B. Juan

C No

2 - 26 - 04

Attachment 3
Network Interconnection

TABLE OF CONTENTS

1. GENERAL.....	3
2. DEFINITIONS: (FOR THE PURPOSE OF THIS ATTACHMENT)	3
3. NETWORK INTERCONNECTION.....	5
4. INTERCONNECTION TRUNK GROUP ARCHITECTURES	8
5. NETWORK DESIGN AND MANAGEMENT FOR INTERCONNECTION	14
6. LOCAL DIALING PARITY.....	18
7. INTERCONNECTION COMPENSATION	18
8. FRAME RELAY SERVICE INTERCONNECTION.....	24
9. ORDERING CHARGES	26
10 BASIC 911 AND E911 INTERCONNECTION.....	26
Rates	Exhibit A
Basic Architecture	Exhibit B
One Way Architecture	Exhibit C
Two Way Architecture	Exhibit D
Supergroup Architecture	Exhibit E

NETWORK INTERCONNECTION

1. GENERAL

- 1.1 The Parties shall provide interconnection with each other's networks for the transmission and routing of telephone exchange service (Local Traffic), ISP-bound Traffic, and exchange access (Switched Access Traffic) on the following terms:

2. DEFINITIONS: (FOR THE PURPOSE OF THIS ATTACHMENT)

For purposes of this attachment only, the following terms shall have the definitions set forth below:

- 2.1 **Automatic Location Identification (ALI)** is a feature by which the address associated with the calling party's telephone number (ANI) is forwarded to the PSAP for display. Access to the ALI database is described in Attachment 2 to this Agreement.
- 2.2 **Automatic Number Identification (ANI)** corresponds to the seven-digit telephone number assigned by the serving local exchange carrier.
- 2.3 **Basic 911 Service (B911)** routes a call to one centralized answering location. The attendant at the answering location obtains the pertinent information that identifies the call and the caller's needs. The attendant then determines the appropriate agency and dials a 7-digit number to transfer the caller to that agency. The calling party's emergency information is verbally relayed to the responding agency and a unit is dispatched to the caller's location.
- 2.4 **Call Termination** has the meaning set forth for "termination" in 47CFR § 51.701(d).
- 2.5 **Call Transport** has the meaning set forth for "transport" in 47 CFR § 51.701(c).
- 2.6 **Call Transport and Termination** is used collectively to mean the switching and transport functions from the Interconnection Point to the last point of switching.
- 2.7 **Common (Shared) Transport** is defined as the transport of the originating Party's traffic by the terminating Party over the terminating Party's common (shared) facilities between (1) the terminating Party's tandem switch and end office switch, (2) between the terminating Party's tandem switches, and/or (3) between the terminating Party's host and remote end office switches. All switches referred herein must be entered into the Local Exchange Routing Guide (LERG).
- 2.8 **Dedicated Interoffice Facility** is defined as a switch transport facility between a Party's Serving Wire Center and the first point of switching within the LATA on the other Party's network.

- 2.9 **End Office Switching** is defined as the function that establishes a communications path between the trunk side and line side of the End Office switch.
- 2.10 **Enhanced 911 Service** provides features not present in Basic 911 Service, including ANI and ALI display, Selective Routing (SR) and other standard and optional features.
- 2.11 **Fiber Meet** is an interconnection arrangement whereby the Parties physically interconnect their networks via an optical fiber interface at which one Party's facilities, provisioning, and maintenance responsibility begins and the other Party's responsibility ends.
- 2.12 **Final Trunk Group** is defined as the trunk group that does not carry overflow traffic.
- 2.13 **Interconnection Point (IP)** is the physical telecommunications equipment interface that interconnects the networks of BellSouth and PBT.
- 2.14 **IntraLATA Toll Traffic** is as defined in Section 7 of this Attachment.
- 2.15 **ISP-bound Traffic** is as defined in Section 7 of this Attachment.
- 2.16 **Local Channel** is defined as a switched transport facility between a Party's Interconnection Point and the IP's Serving Wire Center.
- 2.17 **Local Traffic** is as defined in Section 7 of this Attachment.
- 2.18 **Public Safety Answering Point (PSAP)** is the answering location for 911 calls.
- 2.19 **Reciprocal Trunk Group** is defined as a one-way trunk group carrying BellSouth originated traffic to be terminated by PBT.
- 2.20 **Serving Wire Center** is defined as the wire center owned by one Party from which the other Party would normally obtain dial tone for its IP.
- 2.21 **Selective Routing (SR)** is a standard feature that routes an E911 call from the tandem to the designated PSAP based upon the address of the ANI of the calling party.
- 2.22 **Tandem Switching** is defined as the function that establishes a communications path between two switching offices through a third switching office through the provision of trunk side to trunk side switching.
- 2.23 **Transit Traffic** is traffic originating on PBT's network that is switched and/or transported by BellSouth and delivered to a third party's network, or traffic originating on a third party's network that is switched and/or transported by BellSouth and delivered to PBT's network.

3. NETWORK INTERCONNECTION

- 3.1 This Attachment pertains only to the provision of network interconnection where PBT owns, leases from a third party or otherwise provides its own switch(es).
- 3.2 Network interconnection may be provided by the Parties at any technically feasible point within BellSouth's network. Requests to BellSouth for interconnection at points other than as set forth in this Attachment may be made through the Bona Fide Request/New Business Request (BFR/NBR) process set out in this Agreement.
- 3.2.1 Each Party is responsible for providing, engineering and maintaining the network on its side of the IP. The IP must be located within BellSouth's serving territory in the LATA in which traffic is originating. The IP determines the point at which the originating Party shall pay the terminating Party for the Call Transport and Termination of Local Traffic, ISP-bound Traffic and IntraLATA Toll Traffic.
- 3.2.2 Subject to the requirements for installing additional IP(s), as set forth below, any IP(s) existing prior to the Effective Date of the Agreement will be accepted as initial IP(s) and not require re-grooming. Such existing IP(s) are currently located at each BellSouth access tandem in the LATA in which the Parties are currently exchanging traffic. In the event BellSouth establishes an additional access tandem in a LATA where PBT has an existing IP as of the Effective Date of this Agreement, the terms and conditions of Section 3.2.4 shall apply.
- 3.2.3 Pursuant to the provisions of this Attachment and subject to the terms and conditions of Section 3.2.2 above, the location of the initial IP(s) in a given LATA shall be established at every BellSouth access tandem in that LATA.. When the Parties mutually agree to utilize two-way interconnection trunk groups for the exchange of Local Traffic, ISP-bound Traffic and IntraLATA Toll Traffic between each other, the Parties shall mutually agree to the location of IP(s).
- 3.2.4 Additional IP(s) in a LATA may be established by mutual agreement of the Parties. Notwithstanding the foregoing, additional IP(s) in a particular LATA shall be established, at the request of either Party, when the Local Traffic and ISP-bound Traffic exceeds 8.9 million minutes per month for three consecutive months at the proposed location of the additional IP. BellSouth will not request the establishment of an IP where physical or virtual collocation space is not available or where BellSouth fiber connectivity is not available. When the Parties agree to utilize two-way interconnection trunk groups for the exchange of Local Traffic, ISP-bound Traffic and IntraLATA Toll Traffic the Parties must agree to the location of the IP(s).

3.3 Interconnection via Dedicated Facilities

- 3.3.1 With the exception of Transit Traffic, the Parties shall institute a “bill and keep” compensation plan under which neither Party will charge the other Party recurring and nonrecurring charges as set forth in Exhibit A for trunks (one-way or two-way) and associated dedicated facilities for the exchange of Local Traffic and ISP-bound Traffic. The portions of trunks and facilities utilized for Local Traffic and ISP-bound traffic subject to bill and keep in accordance with this section shall be determined based upon the application of the Percent Local Facility (PLF) Factor as defined in this Attachment. The remaining portion of the trunks and facilities utilized for Local Traffic and ISP-bound traffic shall be billed at the applicable access tariff rates.
- 3.3.1.1 Each party has the obligation to install the appropriate trunks and associated facilities on its respective side of the IP and is responsible for bearing its own costs on its side of the IP.
- 3.3.2 Both parties, as appropriate, shall be compensated for the ordering of trunks and facilities used exclusively for Transit Traffic. The charges applied to the dedicated trunks and facilities used for local Transit Traffic are as set forth in Exhibit A to this Attachment. The charges applied to the dedicated trunks and facilities used for non-local Transit Traffic are as set forth in the applicable BellSouth access tariff.
- 3.3.2.1 Both parties, as appropriate, shall be compensated for the ordering of dedicated trunks and facilities used exclusively for ancillary traffic types including, but not limited to, 911 and OS/DA. The charges applied to the dedicated trunks and facilities ancillary traffic are as set forth in the applicable BellSouth access tariff and are not subject to the “bill and keep” arrangement set forth in Section 3.3.1 above.
- 3.3.2.2 In the event a Party chooses to lease facilities from the other Party in lieu of installing facilities on its side of the IP as required by this Agreement, such facilities are not subject to “bill and keep,” but shall be purchased in accordance with Sections 3.3.3, 3.3.4, and 3.3.5 below.
- 3.3.3 **Local Channel Facilities.** In lieu of providing facilities on its side of the IP, either Party may obtain Local Channel facilities from the other Party. The percentage of Local Channel facilities utilized for Local Traffic shall be determined based upon the application of the Percent Local Facility (PLF) Factor on a statewide basis. The charges applied to the percentage of Local Channel facilities used for Local Traffic as determined by the PLF are as set forth in Exhibit A to this Attachment. The remaining percentage of Local Channel facilities shall be billed at BellSouth’s applicable access tariff rates.

- 3.3.4 **Dedicated Interoffice Facilities.** In lieu of providing facilities on its side of this IP, either Party may obtain Dedicated Interoffice Facilities from the other Party. The percentage of Dedicated Interoffice Facilities utilized for Local Traffic shall be determined based upon the application of the Percent Local Facility (PLF) Factor on a statewide basis. The charges applied to the percentage of the Dedicated Interoffice Facilities used for Local Traffic as determined by the PLF are as set forth in Exhibit A to this Attachment. The remaining percentage of the Dedicated Interoffice Facilities shall be billed at BellSouth's applicable access tariff rates.
- 3.3.5 The facilities purchased pursuant to this Section 3 shall be ordered via the Access Service Request (ASR) process.
- 3.4 **Fiber Meet**
- 3.4.1 Notwithstanding Section 3.2.1, 3.2.2, and 3.2.3 above, if PBT elects to establish interconnection with BellSouth pursuant to a Fiber Meet Local Channel, PBT and BellSouth shall jointly engineer, operate and maintain a Synchronous Optical Network (SONET) transmission system by which they shall interconnect their transmission and routing of Local Traffic via a Local Channel at either the DS1 or DS3 level. The Parties shall work jointly to determine the specific transmission system. However, PBT's SONET transmission system must be compatible with BellSouth's equipment, and the Data Communications Channel (DCC) must be turned off.
- 3.4.2 Each Party, at its own expense, shall procure, install and maintain the agreed upon SONET transmission system in its network.
- 3.4.3 The Parties shall agree to a Fiber Meet point between the BellSouth Serving Wire Center and the PBT Serving Wire Center. The Parties shall deliver their fiber optic facilities to the Fiber Meet point with sufficient spare length to reach the fusion splice point for the Fiber Meet Point. BellSouth shall, at its own expense, provide and maintain the fusion splice point for the Fiber Meet. A building type Common Language Location Identification (CLLI) code will be established for each Fiber Meet point. All orders for interconnection facilities from the Fiber Meet point shall indicate the Fiber Meet point as the originating point for the facility.
- 3.4.4 Upon verbal request by PBT, BellSouth shall allow PBT access to the fusion splice point for the Fiber Meet point for maintenance purposes on PBT's side of the Fiber Meet point.
- 3.4.5 Neither Party shall charge the other for its Local Channel portion of the Fiber Meet facility used exclusively for Local Traffic. All other appropriate charges will apply. PBT shall be billed for a mixed use of the Local Channel using the actual traffic PBT elects to transmit over the facility and the rates from this Agreement and the appropriate tariff(s). Charges for switched and special access services shall be billed in accordance with the applicable access service tariff.

4. INTERCONNECTION TRUNK GROUP ARCHITECTURES

- 4.1 BellSouth and PBT shall establish interconnecting trunk groups and trunk group configurations between networks, including the use of one-way or two-way trunks in accordance with the following provisions set forth in this Agreement. For trunking purposes, traffic will be routed based on the digits dialed by the originating End User and in accordance with the LERG.
- 4.2 PBT shall establish an interconnection trunk group(s) to at least one BellSouth access tandem within the LATA for the delivery of PBT's originated Local Traffic, ISP-bound Traffic and IntraLATA Toll Traffic and for the receipt and delivery of Transit Traffic. To the extent PBT desires to deliver Local Traffic, ISP-bound Traffic, IntraLATA Toll Traffic and/or Transit Traffic to BellSouth access tandems within the LATA, other than the tandems(s) to which PBT has established interconnection trunk groups, PBT shall order Multiple Tandem Access, as described in this Attachment, to such other BellSouth access tandems.
- 4.2.1 Notwithstanding the forgoing, PBT shall establish an interconnection trunk group(s) to all BellSouth access and local tandems in the LATA where PBT has homed (i.e. assigned) its NPA/NXXs. PBT shall home its NPA/NXXs on the BellSouth tandems that serve the exchange rate center areas to which the NPA/NXXs are assigned. The specified exchange rate center assigned to each BellSouth tandem is defined in the LERG. PBT shall enter its NPA/NXX access and/or local tandem homing arrangements into the LERG.
- 4.3 Switched access traffic will be delivered to and from Interexchange Carriers (IXCs) based on PBT's NXX access tandem homing arrangement as specified by PBT in the LERG.
- 4.4 Any PBT interconnection request that (1) deviates from the interconnection trunk group architectures as described in this Agreement, (2) affects traffic delivered to PBT from a BellSouth switch, and (3) requires special BellSouth switch translations and other network modifications will require PBT to submit a BFR/NBR via the BFR/NBR Process as set forth in this Agreement.
- 4.5 Recurring and nonrecurring rates associated with interconnecting trunk groups between BellSouth and PBT are set forth in Exhibit A. To the extent a rate associated with the interconnecting trunk group is not set forth in Exhibit A, the rate shall be as set forth in the appropriate BellSouth tariff for switched access services.
- 4.6 All trunk groups will be provisioned as Signaling System 7 (SS7) capable where technically feasible. If SS7 is not technically feasible multi-frequency (MF) protocol signaling shall be used.

- 4.7 In cases where PBT is also an IXC, the IXC's Feature Group D (FG D) trunk group(s) must remain separate from the local interconnection trunk group(s).
- 4.8 Each Party shall order interconnection trunks and trunk group including trunk and trunk group augmentations via the ASR process. A Firm Order Confirmation (FOC) shall be returned to the ordering Party, after receipt of a valid, error free ASR, within the timeframes set forth in each state's applicable Performance Measures. Notwithstanding the foregoing, blocking situations and projects shall be managed through BellSouth's Carrier Interconnection Switching Center (CISC) Project Management Group and PBT's equivalent trunking group, and FOCs for such orders shall be returned in the timeframes applicable to the project. A project is defined as (1) a new trunk group or (2) a request for more than 96 trunks on a single or multiple group(s) in a given BellSouth local calling area.

4.9 **Interconnection Trunk Groups for Exchange of Local Traffic and Transit Traffic**

Upon mutual agreement of the Parties in a joint planning meeting, the Parties' shall exchange Local Traffic on two-way interconnection trunk group(s) with the quantity of trunks being mutually determined and the provisioning being jointly coordinated. Furthermore, the Parties shall agree upon the IP(s) for two-way interconnection trunk groups transporting both Parties' Local Traffic, ISP-bound Traffic and IntraLATA Toll Traffic. PBT shall order such two-way trunks via the Access Service Request (ASR) process. BellSouth will use the Trunk Group Service Request (TGSR) to request changes in trunking. Furthermore, the Parties shall jointly review trunk performance and forecasts on a periodic basis. The Parties' use of two-way interconnection trunk groups for the transport of Local Traffic, ISP-bound Traffic and IntraLATA Toll Traffic between the Parties does not preclude either Party from establishing additional one-way interconnection trunks for the delivery of its originated Local Traffic, ISP-bound Traffic and IntraLATA Toll Traffic to the other Party.

4.9.1 **BellSouth Access Tandem Interconnection**

BellSouth access tandem interconnection at a single access tandem provides access to those end offices subtending that access tandem (Intratandem Access). Access tandem interconnection is available for any of the following access tandem architectures

4.9.1.1 **Basic Architecture**

In the basic architecture, PBT's originating Local Traffic, ISP-bound Traffic and IntraLATA Toll Traffic and originating and terminating Transit Traffic is transported on a single two-way trunk group between PBT and BellSouth access tandem(s) within a LATA to provide Intratandem Access. This trunk group carries Transit Traffic between PBT and Independent Companies, Interexchange Carriers, other CLECs, CMRS providers that have a Meet Point Billing arrangement with BellSouth, and other network providers with which PBT desires

to exchange traffic. This trunk group also carries PBT originated Transit Traffic transiting a single BellSouth access tandem destined to third party tandems such as an Independent Company tandem or other CLEC tandem. BellSouth originated Local Traffic, ISP-bound Traffic and IntraLATA Toll Traffic is transported on a separate single one-way trunk group terminating to PBT. Other trunk groups for operator services, directory assistance, emergency services and intercept must be established pursuant to the applicable BellSouth tariff if service is requested. The LERG contains current routing and tandem serving arrangements. The basic Architecture is illustrated in Exhibit B.

4.9.1.2 **One-Way Trunk Group Architecture**

In one-way trunk group architecture, the Parties interconnect using three separate trunk groups. A one-way trunk group provides Intratandem Access for PBT-originated Local Traffic, ISP-bound Traffic and IntraLATA Toll Traffic destined for BellSouth End Users. A second one-way trunk group carries BellSouth-originated Local Traffic, ISP-bound Traffic and IntraLATA Toll Traffic destined for PBT End-Users. A two-way trunk group provides Intratandem Access for PBT's originating and terminating Transit Traffic. This trunk group carries Transit Traffic between PBT and Independent Companies, Interexchange Carriers, other CLECs, CMRS providers that have a Meet Point Billing arrangement with BellSouth, and other network providers with which PBT desires to exchange traffic. This trunk group also carries PBT originated Transit Traffic transiting a single BellSouth access tandem destined to third party tandems such as an Independent Company tandem or other CLEC tandem. BellSouth originated Local Traffic, ISP-bound Traffic and IntraLATA Toll Traffic is transported on a separate single one-way trunk group terminating to PBT. Other trunk groups for operator services, directory assistance, emergency services and intercept must be established pursuant to the applicable BellSouth tariff if service is requested. The LERG contains current routing and tandem serving arrangements. The one-way trunk group architecture is illustrated in Exhibit C.

4.9.1.3 **Two-Way Trunk Group Architecture**

The two-way trunk group Architecture establishes one two-way trunk group to provide Intratandem Access for the exchange of Local Traffic, ISP-bound Traffic and IntraLATA Toll Traffic between PBT and BellSouth. In addition, a separate two-way transit trunk group must be established for PBT's originating and terminating Transit Traffic. This trunk group carries Transit Traffic between PBT and Independent Companies, Interexchange Carriers, other CLECs, CMRS providers that have a Meet Point Billing arrangement with BellSouth, and other network providers with which PBT desires to exchange traffic. This trunk group also carries PBT originated Transit Traffic transiting a single BellSouth access tandem destined to third party tandems such as an Independent Company tandem or other CLEC tandem. BellSouth originated traffic may, in order to prevent or remedy traffic blocking situations, be transported on a separate single one-way trunk group terminating to PBT. However, where PBT is responsive in a timely

manner to BellSouth's transport needs for its originated traffic, BellSouth originating traffic will be placed on the two-way Local Traffic trunk group carrying ISP-bound Traffic and IntraLATA Toll Traffic. Other trunk groups for operator services, directory assistance, emergency services and intercept must be established pursuant to the applicable BellSouth tariff if service is requested. The LERG contains current routing and tandem serving arrangements. The two-way trunk group architecture is illustrated in Exhibit D.

4.9.1.4 **Supergroup Architecture**

In the supergroup architecture, the Parties' Local Traffic, ISP-bound Traffic and IntraLATA Toll Traffic and PBT's Transit Traffic are exchanged on a single two-way trunk group between PBT and BellSouth to provide IntraTandem Access to PBT. This trunk group carries Transit Traffic between PBT and Independent Companies, Interexchange Carriers, other CLECs, CMRS providers that have a Meet Point Billing arrangement with BellSouth, and other network providers with which PBT desires to exchange traffic. This trunk group also carries PBT originated Transit Traffic transiting a single BellSouth access tandem destined to third party tandems such as an Independent Company tandem or other CLEC tandem. BellSouth originated traffic may, in order to prevent or remedy traffic blocking situations, be transported on a separate single one-way trunk group terminating to PBT. However, where PBT is responsive in a timely manner to BellSouth's transport needs for its originated traffic, BellSouth originating traffic will be placed on the Supergroup. Other trunk groups for operator services, directory assistance, emergency services and intercept must be established pursuant to the applicable BellSouth tariff if service is requested. The LERG contains current routing and tandem serving arrangements. The supergroup architecture is illustrated in Exhibit E.

4.9.1.5 **Multiple Tandem Access Interconnection**

- 4.9.1.5.1 Where PBT does not choose access tandem interconnection at every BellSouth access tandem within a LATA, PBT may utilize BellSouth's multiple tandem access interconnection (MTA). To utilize MTA PBT must establish an interconnection trunk group(s) at a BellSouth access tandem through multiple BellSouth access tandems within the LATA as required. BellSouth will route PBT's originated Local Traffic, ISP-bound Traffic and IntraLATA Toll Traffic for LATA wide transport and termination. PBT must also establish an interconnection trunk group(s) at all BellSouth access tandems where PBT NXXs are homed as described in Section 4.2.1 above. If PBT does not have NXXs homed at any particular BellSouth access tandem within a LATA and elects not to establish an interconnection trunk group(s) at such BellSouth access tandem, PBT can order MTA in each BellSouth access tandem within the LATA where it does have an interconnection trunk group(s) and BellSouth will terminate PBT's Local Traffic, ISP-bound Traffic and IntraLATA Toll Traffic to End-Users served through those BellSouth access tandems where PBT does not have an interconnection trunk

group(s). MTA shall be provisioned in accordance with BellSouth's Ordering Guidelines.

- 4.9.1.5.2 PBT may also utilize MTA to route its originated Transit Traffic; provided, however, that MTA may not be utilized to route switched access traffic that transits the BellSouth network to an Interexchange Carrier (IXC). Switched access traffic originated by or terminated to PBT will be delivered to and from IXCs based on PBT's NXX access tandem homing arrangement as specified by PBT in the LERG.
- 4.9.1.5.3 Compensation for MTA shall be at the applicable tandem switching and transport charges specified in Exhibit A to this Attachment and shall be billed in addition to any Call Transport and Termination charges.
- 4.9.1.5.4 To the extent PBT does not purchase MTA in a LATA served by multiple access tandems, PBT must establish an interconnection trunk group(s) to every access tandem in the LATA to serve the entire LATA. To the extent PBT routes its traffic in such a way that utilizes BellSouth's MTA service without properly ordering MTA, PBT shall pay BellSouth the associated MTA charges.

4.9.2 **Local Tandem Interconnection**

- 4.9.2.1 Local Tandem Interconnection arrangement allows PBT to establish an interconnection trunk group(s) at BellSouth local tandems for: (1) the delivery of PBT-originated Local Traffic, ISP-bound Traffic and IntraLATA Toll Traffic transported and terminated by BellSouth to BellSouth end offices served by those BellSouth local tandems, and (2) for local Transit Traffic transported by BellSouth for third party network providers who have also established an interconnection trunk group(s) at those BellSouth local tandems.
- 4.9.2.2 When a specified local calling area is served by more than one BellSouth local tandem, PBT must designate a "home" local tandem for each of its assigned NPA/NXXs and establish trunk connections to such local tandems. Additionally, PBT may choose to establish an interconnection trunk group(s) at the BellSouth local tandems where it has no codes homing but is not required to do so. PBT may deliver Local Traffic, ISP-bound Traffic and IntraLATA Toll Traffic to a "home" BellSouth local tandem that is destined for other BellSouth or third party network provider end offices subtending other BellSouth local tandems in the same local calling area where PBT does not choose to establish an interconnection trunk group(s). It is PBT's responsibility to enter its own NPA/NXX local tandem homing arrangements into the LERG either directly or via a vendor in order for other third party network providers to determine appropriate traffic routing to PBT's codes. Likewise, PBT shall obtain its routing information from the LERG.
- 4.9.2.3 Notwithstanding establishing an interconnection trunk group(s) to BellSouth's local tandems, PBT must also establish an interconnection trunk group(s) to

BellSouth access tandems within the LATA on which PBT has NPA/NXXs homed for the delivery of Interexchange Carrier Switched Access (SWA) and toll traffic, and traffic to Type 2A CMRS connections located at the access tandems.

BellSouth shall not switch SWA traffic through more than one BellSouth access tandem. SWA, Type 2A CMRS or toll traffic routed to the local tandem in error will not be backhauled to the BellSouth access tandem for completion. (Type 2A CMRS interconnection is defined in BellSouth's A35 General Subscriber Services Tariff).

4.9.2.4 BellSouth's provisioning of Local Tandem Interconnection assumes that PBT has executed the necessary local interconnection agreements with the other third party network providers subtending those local tandems as required by the Act.

4.9.3 **Direct End Office-to-End Office Interconnection**

4.9.3.1 Direct End Office-to-End Office one-way or two-way interconnection trunk groups allow for the delivery of a Party's originating Local Traffic, ISP-bound Traffic and IntraLATA Toll Traffic to the terminating Party on a direct end office-to-end office basis.

4.9.3.2 The Parties shall utilize direct end office-to-end office trunk groups under any one of the following conditions:

4.9.3.2.1 Tandem Exhaust - If a tandem through which the Parties are interconnected is unable to, or is forecasted to be unable to support additional traffic loads for any period of time, the Parties will mutually agree on an end office trunking plan that will alleviate the tandem capacity shortage and ensure completion of traffic between PBT and BellSouth.

4.9.3.2.2 Traffic Volume -To the extent either Party has the capability to measure the amount of traffic between PBT's switch and a BellSouth end office and where such traffic exceeds or is forecasted to exceed a single DS1 of traffic per month, then the Parties shall install and retain direct end office trunking sufficient to handle such traffic volumes. Either Party will install additional capacity between such points when overflow traffic exceeds or is forecasted to exceed a single DS1 of traffic per month. In the case of one-way trunking, additional trunking shall only be required by the Party whose trunking has achieved the preceding usage threshold.

4.9.3.2.3 Mutual Agreement - The Parties may install direct end office trunking upon mutual agreement in the absence of conditions (1) or (2) above.

4.9.4 **Transit Traffic Trunk Group**

Transit Traffic trunks can either be two-way trunks or two one-way trunks ordered by PBT to deliver and receive Transit Traffic. Establishing Transit Traffic trunks at BellSouth access and local tandems provides intratandem access to the third

parties also interconnected at those tandems. In accordance with this Agreement, PBT shall be responsible for ordering -any one-way or two-way trunks carrying Transit Traffic and PBT shall be responsible for paying for such ordered trunks carrying Transit Traffic.

4.9.4.1 **Toll Free Traffic**

4.9.4.1.1 If PBT chooses BellSouth to perform the Service Switching Point (SSP) Function (i.e., handle Toll Free database queries) from BellSouth's switches, all PBT originating Toll Free traffic will be routed over the Transit Traffic Trunk Group and shall be delivered using GR-394 format. Carrier Code "0110" and Circuit Code (to be determined for each LATA) shall be used for all such calls.

4.9.4.1.2 PBT may choose to perform its own Toll Free database queries from its switch. In such cases, PBT will determine the nature (local/intraLATA/interLATA) of the Toll Free call (local/IntraLATA/InterLATA) based on the response from the database. If the call is a BellSouth local or intraLATA Toll Free call, PBT will route the post-query local or IntraLATA converted ten-digit local number to BellSouth over the local or intraLATA trunk group. If the call is a third party (ICO, IXC, CMRS or other CLEC) local or intraLATA Toll Free call, PBT will route the post-query local or intraLATA converted ten-digit local number to BellSouth over the Transit Traffic Trunk Group and PBT shall provide to BellSouth a Toll Free billing record when appropriate. If the query reveals the call is an interLATA Toll Free call, PBT will route the post-query interLATA Toll Free call (1) directly from its switch for carriers interconnected with its network or (2) over the Transit Traffic Trunk Group to carriers that are not directly connected to PBT's network but that are connected to BellSouth's access tandem.

4.9.5 All post-query Toll Free calls for which PBT performs the SSP function, if delivered to BellSouth, shall be delivered using GR-394 format for calls destined to IXCs, and GR-317 format for calls destined to end offices that directly subtend a BellSouth access tandem within the LATA.

5. **NETWORK DESIGN AND MANAGEMENT FOR INTERCONNECTION**

5.1 Network Management and Changes. The Parties will exchange toll-free maintenance contact numbers and escalation procedures. The Parties will provide public notice of network changes in accordance with applicable federal and state rules and regulations.

5.2 Interconnection Technical Standards. The interconnection of all networks will be based upon accepted industry/national guidelines for transmission standards and traffic blocking criteria. Interconnecting facilities shall conform, at a minimum, to the telecommunications industry standard of DS-1 pursuant to Telcordia Standard

No. TR-NWT-00499. Where PBT chooses to utilize Signaling System 7 signaling, also known as Common Channel Signaling (SS7), SS7 connectivity is required between the PBT switch and the BellSouth Signaling Transfer Point (STP). BellSouth will provide SS7 signaling using Common Channel Signaling Access Capability in accordance with the technical specifications set forth in the BellSouth Guidelines to Technical Publication, TR-TSV-000905. Facilities of each Party shall provide the necessary on-hook, off-hook answer and disconnect supervision and shall provide calling number ID (Calling Party Number) when technically feasible.

- 5.3 Quality of Interconnection. The local interconnection for the transmission and routing of telephone exchange service and exchange access that each Party provides to each other will be at least equal in quality to what it provides to itself and any subsidiary or affiliate, where technically feasible, or to any other Party to which each Party provides local interconnection.
- 5.4 Network Management Controls. Both Parties will work cooperatively to apply sound network management principles by invoking appropriate network management controls (e.g., call gapping) to alleviate or prevent network congestion.
- 5.5 SS7 Signaling. Both Parties will utilize LEC-to-LEC SS7 Signaling, where available, in conjunction with all traffic in order to enable full interoperability of CLASS features and functions except for call return. All SS7 signaling parameters will be provided, including but not limited to automatic number identification (ANI), originating line information (OLI) calling company category and charge number. All privacy indicators will be honored, and the Parties will exchange Transactional Capabilities Application Part (TCAP) messages to facilitate full interoperability of SS7-based features between the respective networks. Neither Party shall alter the SS7 parameters, or be a party to altering such parameters, or knowingly pass SS7 parameters that have been altered in order to circumvent appropriate interconnection charges.
- 5.6 Signaling Call Information. BellSouth and PBT will send and receive 10 digits for Local Traffic. Additionally, BellSouth and PBT will exchange the proper call information, i.e. originated call company number and destination call company number, CIC, and OZZ, including all proper translations for routing between networks and any information necessary for billing.
- 5.7 **Forecasting for Trunk Provisioning**
- 5.7.1 Within six (6) months after execution of this Agreement, PBT shall provide an initial interconnection trunk group forecast for each LATA in which it plans to provide service within BellSouth's region. Upon receipt of PBT's forecast, the Parties shall conduct a joint planning meeting to develop a joint interconnection trunk group forecast. Each forecast provided under this Section shall be deemed

“Confidential Information” under the General Terms and Conditions of this Agreement.

- 5.7.1.1 At a minimum, the forecast shall include the projected quantity of Transit Trunks, PBT-to-BellSouth one-way trunks (PBT Trunks), BellSouth-to-PBT one-way trunks (Reciprocal Trunk Groups) and/or two-way interconnection trunks, if the Parties have agreed to interconnect using two-way trunking to transport the Parties’ Local Traffic and IntraLATA Toll Traffic. The quantities shall be projected for a minimum of six months and shall include an estimate of the current year plus the next two years total forecasted quantities. The Parties shall mutually develop Reciprocal Trunk Groups and/or two-way interconnection trunk forecast quantities.
- 5.7.1.2 All forecasts shall include, at a minimum, Access Carrier Terminal Location (ACTL), trunk group type (local/intraLATA toll, Transit, Operator Services, 911, etc.), A location/Z location (CLLI codes for PBT location and BellSouth location where the trunks shall terminate), interface type (e.g., DS1), Direction of Signaling, Trunk Group Number, if known, (commonly referred to as the 2-6 code) and forecasted trunks in service each year (cumulative).
- 5.7.2 Once initial interconnection trunk forecasts have been developed, PBT shall continue to provide interconnection trunk forecasts on a semiannual basis or at otherwise mutually agreeable intervals. PBT shall use its best efforts to make the forecasts as accurate as possible based on reasonable engineering criteria. The Parties shall continue to develop Reciprocal Trunk Group and/or two-way interconnection trunk forecasts as described in Section 5.7.1.1.
- 5.7.3 The submitting and development of interconnection trunk forecasts shall not replace the ordering process for local interconnection trunks. Each Party shall exercise its best efforts to provide the quantity of interconnection trunks mutually forecasted. However, the provision of the forecasted quantity of interconnection trunks is subject to trunk terminations and facility capacity existing at the time the trunk order is submitted. Furthermore, the receipt and development of trunk forecasts does not imply any liability for failure to perform if capacity (trunk terminations or facilities) is not available for use at the forecasted time.

5.8 **Trunk Utilization**

- 5.8.1 For the Reciprocal Trunk Groups that are Final Trunk Groups (Reciprocal Final Trunk Groups), BellSouth and PBT shall monitor traffic on each interconnection Reciprocal Final Trunk Group that is ordered and installed. The Parties agree that the Reciprocal Final Trunk Groups will be utilized at 60 percent (60%) of the time consistent busy hour utilization level within 90 days of installation. The Parties agree that the Reciprocal Final Trunk Groups will be utilized at eighty percent (80%) of the time consistent busy hour utilization level within 180 days of installation. Any Reciprocal Final Trunk Group not meeting the minimum

thresholds set forth in this Section are defined as “Under-utilized” trunks. BellSouth may disconnect any Under-utilized Reciprocal Final Trunk Groups and PBT shall refund to BellSouth the associated nonrecurring and recurring trunk and facility charges paid by BellSouth, if any.

- 5.8.1.1 BellSouth’s CISC will notify PBT of any under-utilized Reciprocal Trunk Groups and the number of such trunk groups that BellSouth wishes to disconnect. BellSouth will provide supporting information either by email or facsimile to the designated PBT interface. PBT will provide concurrence with the disconnection in seven (7) business days or will provide specific information supporting why the trunks should not be disconnected. Such supporting information should include expected traffic volumes (including traffic volumes generated due to Local Number Portability) and the timeframes within which PBT expects to need such trunks. BellSouth’s CISC Project Manager and Circuit Capacity Manager will discuss the information with PBT to determine if agreement can be reached on the number of Reciprocal Final Trunk Groups to be removed. If no agreement can be reached, BellSouth will issue disconnect orders to PBT. The due date of these orders will be four weeks after PBT was first notified in writing of the underutilization of the trunk groups.
- 5.8.2 To the extent that any interconnection trunk group is utilized at a time-consistent busy hour of eighty percent (80%) or greater, the Parties may review the trunk groups and, if necessary, shall negotiate in good faith for the installation of augmented facilities.
- 5.8.3 For the two-way trunk groups, BellSouth and PBT shall monitor traffic on each interconnection trunk group that is ordered and installed. The Parties agree that within 90 days of the installation of the BellSouth two-way trunk or trunks, the trunks will be utilized at 60 percent (60%) of the time consistent busy hour utilization level. The Parties agree that within 180 days of the installation of a trunk or trunks, the trunks will be utilized at eighty percent (80%) of the time consistent busy hour utilization level. Any trunk or trunks not meeting the minimum thresholds set forth in this Section are defined as “Under-utilized” trunks. BellSouth will request the disconnection of any Under-utilized two-way trunk(s) and PBT shall refund to BellSouth the associated nonrecurring and recurring trunk and facility charges paid by BellSouth, if any.
- 5.8.3.1 BellSouth’s LISC will notify PBT of any under-utilized two-way trunk groups and the number of trunks that BellSouth wishes to disconnect. BellSouth will provide supporting information either by email or facsimile to the designated PBT interface. PBT will provide concurrence with the disconnection in seven (7) business days or will provide specific information supporting why the two-way trunks should not be disconnected. Such supporting information should include expected traffic volumes (including traffic volumes generated due to Local Number Portability) and the timeframes within which PBT expects to need such

trunks. BellSouth's CISC Project Manager and Circuit Capacity Manager will discuss the information with PBT to determine if agreement can be reached on the number of trunks to be removed. If no agreement can be reached, PBT will issue disconnect orders to BellSouth. The due date of these orders will be four weeks after PBT was first notified in writing of the underutilization of the trunk groups.

- 5.8.3.2 To the extent that any interconnection trunk group is utilized at a time-consistent busy hour of eighty percent (80%) or greater, the Parties may review the trunk groups and, if necessary, shall negotiate in good faith for the installation of augmented facilities.

6. LOCAL DIALING PARITY

- 6.1 BellSouth and PBT shall provide local and toll dialing parity, as defined in FCC rules and regulations, with no unreasonable dialing delays. Dialing parity shall be provided for all originating telecommunications services that require dialing to route a call.

7. INTERCONNECTION COMPENSATION

7.1 Compensation for Call Transportation and Termination for Local Traffic, ISP-bound Traffic and IntraLATA Toll Traffic

- 7.1.1 For the purposes of this Attachment and for reciprocal compensation between the Parties pursuant to this Attachment, Local Traffic is defined as any telephone call that is originated by an end user of one Party in one LATA and terminated to an end user of the other Party in the same LATA, except for those calls that originate or terminate through switched access arrangements as established by the ruling regulatory body.

- 7.1.1.1 Additionally, Local Traffic includes any cross boundary, voice-to-voice intrastate, interLATA or interstate, interLATA calls established as a local call by the ruling regulatory body.

- 7.1.2 ISP-bound Traffic is defined as calls to an information service provider or Internet service provider (ISP) that are dialed by using a local dialing pattern (7 or 10 digits) by a calling party in one LATA to an ISP server or modem in the same LATA. ISP-bound Traffic is not Local Traffic subject to reciprocal compensation, but instead is information access traffic subject to the FCC's jurisdiction.

- 7.1.3 Notwithstanding the definitions of Local Traffic and ISP-bound traffic above, and pursuant to the FCC's Order on Remand and Report and Order in CC Docket 99-68 released April 27, 2001 (ISP Order on Remand), BellSouth and PBT agree to the rebuttable presumption that all combined circuit switched Local and ISP-bound Traffic delivered to BellSouth or PBT that exceeds a 3:1 ratio of terminating to

originating traffic on a statewide basis shall be considered ISP-bound traffic for compensation purposes. BellSouth and PBT further agree to the rebuttable presumption that all combined circuit switched Local and ISP-bound Traffic delivered to BellSouth or PBT that does not exceed a 3:1 ratio of terminating to originating traffic on a statewide basis shall be considered Local Traffic for compensation purposes.

- 7.1.4 Neither Party shall pay compensation to the other Party for per minute of use rate elements associated with the Call Transport and Termination of Local Traffic or ISP-bound Traffic.
- 7.1.5 The appropriate elemental rates set forth in Exhibit A of this Attachment shall apply for Transit Traffic as described in Sections 7.6 and 7.6.1 below and to Multiple Tandem Access as described in Section 4.9.1.5 above.
- 7.1.6 Neither Party shall represent Switched Access Traffic as Local Traffic or ISP-bound Traffic for purposes of determining compensation for the call.
- 7.1.7 IntraLATA Toll Traffic is defined as all traffic that originates and terminates within a single LATA that is not Local or ISP-bound traffic under this Attachment.
- 7.1.7.1 For terminating its intraLATA toll traffic on the other company's network, the originating Party will pay the terminating Party BellSouth's current intrastate or interstate, whichever is appropriate, terminating switched access tariff rates as set forth in BellSouth's Access Services Tariffs as filed and in effect with the FCC or Commission. The appropriate charges will be determined by the routing of the call. Additionally, if one Party is the other Party's End User's presubscribed interexchange carrier or if one Party's End User uses the other Party as an interexchange carrier on a 101XXXX basis, the originating party will charge the other Party the appropriate BellSouth originating switched access tariff rates as set forth in BellSouth's Intrastate or Interstate Access Services Tariff as filed and in effect with the FCC or appropriate Commission.
- 7.1.8 If PBT assigns NPA/NXXs to specific BellSouth rate centers within the LATA and assigns numbers from those NPA/NXXs to PBT End Users physically located outside of that LATA, BellSouth traffic originating from within the LATA where the NPA/NXXs are assigned and delivered to a PBT customer physically located outside of such LATA, shall not be deemed Local Traffic. Further, PBT agrees to identify such interLATA traffic to BellSouth and to compensate BellSouth for originating and transporting such interLATA traffic to PBT at BellSouth's switched access tariff rates.
- 7.2 If PBT does not identify such interLATA traffic to BellSouth, to the best of BellSouth's ability BellSouth will determine which whole PBT NPA/NXXs on which to charge the applicable rates for originating network access service as

reflected in BellSouth's Access Service Tariff. BellSouth shall make appropriate billing adjustments if PBT can provide sufficient information for BellSouth to determine whether or not said traffic is Local or ISP-bound Traffic.

7.3 **Jurisdictional Reporting**

7.3.1 **Percent Local Use.** Each Party shall report to the other a Percent Local Usage (PLU) factor. The application of the PLU will determine the amount of local or ISP-bound minutes to be billed to the other Party. Each Party shall update its PLU on the first of January, April, July and October of the year and shall send it to the other Party to be received no later than 30 days after the first of each such month based on local and ISP-bound usage for the past three months ending the last day of December, March, June and September, respectively. Requirements associated with PLU calculation and reporting shall be as set forth in BellSouth's Jurisdictional Factors Reporting Guide, as it is amended from time to time.

7.3.2 **Percent Local Facility.** Each Party shall report to the other a Percent Local Facility (PLF) factor. The application of the PLF will determine the portion of switched dedicated transport to be billed per the local jurisdiction rates. The PLF shall be applied to Multiplexing, Local Channel and Interoffice Channel Switched Dedicated Transport utilized in the provision of local interconnection trunks. Each Party shall update its PLF on the first of January, April, July and October of the year and shall send it to the other Party to be received no later than 30 days after the first of each such month to be effective the first bill period the following month, respectively. Requirements associated with PLU and PLF calculation and reporting shall be as set forth in BellSouth's Jurisdictional Factors Reporting Guide, as it is amended from time to time.

7.3.3 **Percent Interstate Usage.** Each Party shall report to the other the projected Percent Interstate Usage (PIU) factor. All jurisdictional report requirements, rules and regulations for Interexchange Carriers specified in BellSouth's Intrastate Access Services Tariff will apply to PBT. After interstate and intrastate traffic percentages have been determined by use of PIU procedures, the PLU and PLF factors will be used for application and billing of local interconnection. Each Party shall update its PIUs on the first of January, April, July and October of the year and shall send it to the other Party to be received no later than 30 days after the first of each such month, for all services showing the percentages of use for the past three months ending the last day of December, March, June and September.

7.3.4 Notwithstanding the provisions in Section 7.3.1, 7.3.2, and 7.3.3 above, where the terminating Party has message recording technology that identifies the jurisdiction of traffic terminated as defined in this Agreement, such information shall, at the terminating Party's option, be utilized to determine the appropriate jurisdictional reporting factors (PLU, PIU, and/or PLF), in lieu of those provided by the originating Party. In the event that the terminating Party opts to utilize its own data to determine jurisdictional reporting factors, such terminating Party shall

notify the originating Party at least 15 days prior to the beginning of the calendar quarter in which the terminating Party will begin to utilize its own data. Such factors shall subject to the Dispute Resolution provisions in this Agreement, as well as the Audit provisions set forth in 7.3.5 below.

- 7.3.5 **Audits.** On thirty (30) days written notice, each Party must provide the other the ability and opportunity to conduct an annual audit to ensure the proper billing of traffic. BellSouth and PBT shall retain records of call detail for a minimum of nine months from which the PLU, PLF and/or PIU can be ascertained. The audit shall be conducted during normal business hours at an office designated by the Party being audited. Audit requests shall not be submitted more frequently than one (1) time per calendar year. Audits shall be performed by a mutually acceptable independent auditor paid for by the Party requesting the audit. The PLF, PLU and/or PIU shall be adjusted based upon the audit results and shall apply for the quarter the audit was completed, for the quarter prior to the completion of the audit, and for the two quarters following the completion of the audit. If, as a result of an audit, either Party is found to have overstated the PLF, PLU and/or PIU by twenty percentage points (20%) or more, that Party shall reimburse the auditing Party for the cost of the audit.

7.4 **Compensation for 8XX Traffic**

- 7.4.1 Compensation for 8XX Traffic. Each Party shall pay the other the appropriate switched access charges set forth in the BellSouth intrastate or interstate switched access tariffs. PBT will pay BellSouth the database query charge as set forth in the BellSouth intrastate or interstate switched access tariffs as applicable.

- 7.4.2 Records for 8XX Billing. Each Party will provide to the other the appropriate records necessary for billing intraLATA 8XX customers. The records provided will be in a standard EMI format.

- 7.4.3 8XX Access Screening. BellSouth's provision of 8XX Toll Free Dialing (TFD) to PBT requires interconnection from PBT to BellSouth's 8XX Signal Channel Point (SCP). Such interconnections shall be established pursuant to BellSouth's Common Channel Signaling Interconnection Guidelines and Telcordia's CCS Network Interface Specification document, TR-TSV-000905. PBT shall establish SS7 interconnection at the BellSouth Local Signal Transfer Points serving the BellSouth 8XX SCPs that PBT desires to query. The terms and conditions for 8XX TFD are set out in BellSouth's Intrastate Access Services Tariff.

7.5 **Mutual Provision of Switched Access Service**

- 7.5.1 Switched Access Traffic. Switched Access Traffic is described as telephone calls requiring local transmission or switching services for the purpose of the origination or termination of Telephone Toll Service. Switched Access Traffic includes, but is not limited to, the following types of traffic: Feature Group A, Feature Group B,

Feature Group C, Feature Group D, toll free access (e.g., 8XX), 900 access and their successors. Additionally, any Public Switched Telephone Network interexchange telecommunications traffic, regardless of transport protocol method, where the originating and terminating points, end-to-end points, are in different LATAs, or are in the same LATA and the Parties' Switched Access services are used for the origination or termination of the call, shall be considered Switched Access Traffic. Irrespective of transport protocol method used, a call which originates in one LATA and terminates in another LATA (i.e., the end-to-end points of the call) or in which the Parties' Switched Access Services are used for the origination or termination of the call, shall not be considered Local Traffic or ISP-bound Traffic.

- 7.5.2 If the BellSouth End User chooses PBT as their presubscribed interexchange carrier, or if the BellSouth End User uses PBT as an interexchange carrier on a 101XXXX basis, BellSouth will charge PBT the appropriate BellSouth tariff charges for originating switched access services.
- 7.5.3 Where the originating Party delivers a call to the terminating Party over switched access facilities, the originating Party will pay the terminating Party terminating, switched access charges as set forth in BellSouth's Intrastate or Interstate Access Services Tariff, as appropriate.
- 7.5.4 When PBT's end office switch provides an access service connection to or from an interexchange carrier (IXC) by a direct trunk group to the IXC utilizing BellSouth facilities, each Party will provide its own access services to the IXC and bill on a multi-bill, multi-tariff meet-point basis. Each Party will bill its own access services rates to the IXC with the exception of the interconnection charge. The interconnection charge will be billed by PBT as the Party providing the end office function. Each party will use the Multiple Exchange Carrier Access Billing (MECAB) guidelines to establish meet point billing for all applicable traffic. The Parties shall utilize a thirty (30) day billing period.
- 7.5.4.1 When PBT's end office subtends the BellSouth Access Tandem switch for receipt or delivery of switched access traffic and provides an access service connection to or from an IXC via BellSouth's Access Tandem switch, BellSouth, as the tandem company agrees to provide to PBT, as the End Office Company, as defined in MECAB, at no charge, all the switched access detail usage data, recorded at the access tandem, within no more than sixty (60) days after the recording date. Each Party will notify the other when it is not feasible to meet these requirements. As business requirements change, data reporting requirements may be modified as necessary.
- 7.5.5 BellSouth, as the tandem provider company, will retain for a minimum period of sixty (60) days, access message detail sufficient to recreate any data that is lost or damaged by the tandem provider company or any third party involved in processing or transporting data.

- 7.5.6 BellSouth, as the tandem provider company, agrees to recreate the lost or damaged data within forty-eight (48) hours of notification by the other or by an authorized third party handling the data.
- 7.5.7 Any claims against BellSouth, as the tandem provider company, for unbillable or uncollectible revenue should be filed with the tandem provider company within 120 days of the usage date.
- 7.5.8 BellSouth, as the tandem provider company shall keep records of its billing activities relating to jointly-provided Intrastate and Interstate access services in sufficient detail to permit the Subsequent Billing Party to, by formal or informal review or audit, to verify the accuracy and reasonableness of the jointly-provided access billing data provided by the Initial Billing Party. Each Party agrees to cooperate in such formal or informal reviews or audits and further agrees to jointly review the findings of such reviews or audits in order to resolve any differences concerning the findings thereof.
- 7.5.9 PBT agrees not to deliver switched access traffic to BellSouth for termination except over PBT ordered switched access trunks and facilities.
- 7.6 **Transit Traffic**
- 7.6.1 BellSouth shall provide tandem switching and transport services for PBT's Transit Traffic. Rates for local Transit Traffic and ISP-bound Transit Traffic shall be the applicable Call Transport and Termination charges as set forth in Exhibit A to this Attachment. Rates for Switched Access Transit Traffic shall be the applicable charges as set forth in BellSouth Interstate or Intrastate Switched Access tariffs. Billing associated with all Transit Traffic shall be pursuant to MECAB guidelines. Traffic between PBT and Wireless Type 1 third parties shall not be treated as Transit Traffic from a routing or billing perspective. Traffic between PBT and Wireless Type 2A or a third party CLEC utilizing BellSouth switching shall not be treated as Transit Traffic from a routing or billing perspective until BellSouth and the Wireless carrier or a third party CLEC utilizing BellSouth switching have the capability to properly meet-point-bill in accordance with MECAB guidelines.
- 7.6.2 The delivery of traffic that transits the BellSouth network and is transported to another carrier's network is excluded from any BellSouth billing guarantees. BellSouth agrees to deliver Transit Traffic to the terminating carrier; provided, however, that PBT is solely responsible for negotiating and executing any appropriate contractual agreements with the terminating carrier for the exchange of Transit Traffic through the BellSouth network. BellSouth will not be liable for any compensation to the terminating carrier or to PBT. In the event that the terminating third party carrier imposes on BellSouth any charges or costs for the delivery of Transit Traffic, PBT shall reimburse BellSouth for such costs. Additionally, the Parties agree that any billing to a third party or other

telecommunications carrier under this section shall be pursuant to MECAB procedures.

8. FRAME RELAY SERVICE INTERCONNECTION

- 8.1 In addition to the Local Interconnection services set forth above, BellSouth will offer a network to network Interconnection arrangement between BellSouth's and PBT's frame relay switches as set forth below. The following provisions will apply only to Frame Relay Service and Exchange Access Frame Relay Service and Managed Shared Frame Relay Service in those states in which PBT is certified and providing Frame Relay Service as a Local Exchange Carrier and where traffic is being exchanged between PBT and BellSouth Frame Relay Switches in the same LATA.
- 8.2 The Parties agree to establish two-way Frame Relay facilities between their respective Frame Relay Switches to the mutually agreed upon Frame Relay Service point(s) of interconnection (IP(s)) within the LATA. All IPs shall be within the same Frame Relay Network Serving Areas as defined in Section A40 of BellSouth's General Subscriber Service Tariff except as set forth in this Attachment.
- 8.3 Upon the request of either Party, such interconnection will be established where BellSouth and PBT have Frame Relay Switches in the same LATA. Where there are multiple Frame Relay switches in one central office, an interconnection with any one of the switches will be considered an interconnection with all of the switches at that central office for purposes of routing packet traffic.
- 8.4 The Parties agree to provision local and intraLATA Frame Relay Service and Exchange Access Frame Relay Service and Managed Shared Frame Relay Service (both intrastate and interstate) over Frame Relay interconnection facilities between the respective Frame Relay switches and the IPs.
- 8.5 The Parties agree to assess each other reciprocal charges for the facilities that each provides to the other according to the Percent Local Circuit Use Factor (PLCU), determined as follows:
- 8.5.1 If the data packets originate and terminate in locations in the same LATA, and are consistent with the local definitions of the Agreement, the traffic is considered local. Frame Relay framed packet data is transported within Virtual Circuits (VC). For the purposes of this Agreement, if all the data packets transported within a VC remain within the LATA, then consistent with the local definitions in this Agreement, the traffic on that VC is local (Local VC).
- 8.5.2 If the originating and terminating locations of the two-way packet data traffic are not in the same LATA, the traffic on that VC is interLATA (InterLATA VC).

- 8.5.3 The PLCU is determined by dividing the total number of Local VCs, by the total number of VCs on each Frame Relay facility. To facilitate implementation, PBT may determine its PLCU in aggregate, by dividing the total number of Local VCs in a given LATA by the total number VCs in that LATA. The Parties agree to renegotiate the method for determining PLCU, at BellSouth's request, and within 90 days, if BellSouth notifies PBT that it has found that this method does not adequately represent the PLCU.
- 8.5.4 If there are no VCs on a facility when it is billed, the PLCU will be zero.
- 8.5.5 BellSouth will provide the circuit between the Parties' respective Frame Relay Switches. The Parties will be compensated as follows: BellSouth will invoice, and PBT will pay, the total nonrecurring and recurring charges for the circuit based upon the rates set forth in BellSouth's Interstate Access Tariff, FCC No. 1. PBT will then invoice, and BellSouth will pay, an amount calculated by multiplying the BellSouth billed charges for the circuit by one-half of PBT's PLCU.
- 8.6 The Parties agree to compensate each other for Frame Relay network-to-network interface (NNI) ports based upon the NNI rates set forth in BellSouth's Interstate Access Tariff, FCC No. 1. Compensation for each pair of NNI ports will be calculated as follows: BellSouth will invoice, and PBT will pay, the total nonrecurring and recurring charges for the NNI port. PBT will then invoice, and BellSouth will pay, an amount calculated by multiplying the BellSouth billed nonrecurring and recurring charges for the NNI port by PBT's PLCU.
- 8.7 Each Party agrees that there will be no charges to the other Party for its own subscriber's Permanent Virtual Circuit (PVC) rate elements for the local PVC segment from its Frame Relay switch to its own subscriber's premises. PVC rate elements include the Data Link Connection Identifier (DLCI) and Committed Information Rate (CIR).
- 8.8 For the PVC segment between the PBT and BellSouth Frame Relay switches, compensation for the PVC charges is based upon the rates in BellSouth's Interstate Access Tariff, FCC No. 1.
- 8.9 Compensation for PVC rate elements will be calculated as follows:
- 8.9.1 If PBT orders a VC connection between a BellSouth subscriber's PVC segment and a PVC segment from the BellSouth Frame Relay switch to the PBT Frame Relay switch, BellSouth will invoice, and PBT will pay, the total nonrecurring and recurring PVC charges for the PVC segment between the BellSouth and PBT Frame Relay switches. If the VC is a Local VC, PBT will then invoice and BellSouth will pay, the total nonrecurring and recurring PVC charges billed for that segment. If the VC is not local, no compensation will be paid to PBT for the PVC segment.

- 8.9.2 If BellSouth orders a Local VC connection between a PBT subscriber's PVC segment and a PVC segment from the PBT Frame Relay switch to the BellSouth Frame Relay switch, BellSouth will invoice, and PBT will pay, the total nonrecurring and recurring PVC and CIR charges for the PVC segment between the BellSouth and PBT Frame Relay switches. If the VC is a Local VC, PBT will then invoice and BellSouth will pay the total nonrecurring and recurring PVC and CIR charges billed for that segment. If the VC is not local, no compensation will be paid to PBT for the PVC segment.
- 8.9.3 The Parties agree to compensate each other for requests to change a PVC segment or PVC service order record, according to the Feature Change charge as set forth in the BellSouth access tariff BellSouth Tariff FCC No. 1.
- 8.9.4 If PBT requests a change, BellSouth will invoice and PBT will pay a Feature Change charge for each affected PVC segment.
- 8.9.4.1 If BellSouth requests a change to a Local VC, PBT will invoice and BellSouth will pay a Feature Change charge for each affected PVC segment.
- 8.9.5 The Parties agree to limit the sum of the CIR for the VCs on a DS1 NNI port to not more than three times the port speed, or not more than six times the port speed on a DS3 NNI port.
- 8.9.6 Except as expressly provided herein, this Agreement does not address or alter in any way either Party's provision of Exchange Access Frame Relay Service, Managed Shared Frame Relay Service or interLATA Frame Relay Service. All charges by each Party to the other for carriage of Exchange Access Frame Relay Service or interLATA Frame Relay Service are included in the BellSouth access tariff BellSouth Tariff FCC No. 1.
- 8.10 PBT will identify and report quarterly to BellSouth the PLCU of the Frame Relay facilities it uses, per Section 8.5.3 above.
- 8.11 Either Party may request a review or audit of the various service components, consistent with the provisions of section E2 of the BellSouth State Access Services tariffs or Section 2 of the BellSouth FCC No.1 Tariff.

9. ORDERING CHARGES

- 9.1 The terms, conditions and rates for Ordering Charges are as set forth in FCC Tariff for Access Service Records.

10. BASIC 911 AND E911 INTERCONNECTION

- 10.1 Basic 911 and E911 provides a caller access to the applicable emergency service bureau by dialing 911.

- 10.2 Basic 911 Interconnection. BellSouth will provide to PBT a list consisting of each municipality that subscribes to Basic 911 service. The list will also provide, if known, the E911 conversion date for each municipality and, for network routing purposes, a ten-digit directory number representing the appropriate emergency answering position for each municipality subscribing to 911. PBT will be required to arrange to accept 911 calls from its end users in municipalities that subscribe to Basic 911 service and translate the 911 call to the appropriate 10-digit directory number as stated on the list provided by BellSouth. PBT will be required to route that call to BellSouth at the appropriate 911 tandem. When a municipality converts to E911 service, PBT will be required to begin using E911 procedures.
- 10.3 E911 Interconnection. PBT shall install a minimum of two dedicated trunks originating from its Serving Wire Center and terminating to the appropriate E911 tandem. The Serving Wire Center must be in the same LATA as the E911 tandem. The dedicated trunks shall be, at a minimum, DS0 level trunks configured as part of a digital (1.544 Mb/s) interface (DS1 facility). The configuration shall use CAMA-type signaling with multifrequency (MF) pulsing that will deliver ANI with the voice portion of the call. If the user interface is digital, MF pulses as well as other AC signals shall be encoded per the u-255 Law convention. PBT will be required to provide BellSouth daily updates to the E911 database. PBT will be required to forward 911 calls to the appropriate E911 tandem along with ANI based upon the current E911 end office to tandem homing arrangement as provided by BellSouth. If the E911 tandem trunks are not available, PBT will be required to route the call to a designated 7-digit or 10-digit local number residing in the appropriate Public Service Answering Point (PSAP). This call will be transported over BellSouth's interoffice network and will not carry the ANI of the calling party. PBT shall be responsible for providing BellSouth with complete and accurate data for submission to the 911/E911 database for the purpose of providing 911/E911 to its end users.
- 10.4 Rates. BellSouth will impose applicable charges on PBT for BellSouth trunking arrangements. Rates for trunking arrangements are as set forth in Exhibit A of this Attachment. In addition PBT will be responsible for charges for the facilities that the E911 trunks will ride. Facility rates are as set forth in the access tariff.
- 10.5 The detailed practices and procedures for 911/E911 interconnection are contained in the E911 Local Exchange Carrier Guide For Facility-Based Providers as amended from time to time during the term of this Agreement.

Exhibit B

Basic Architecture

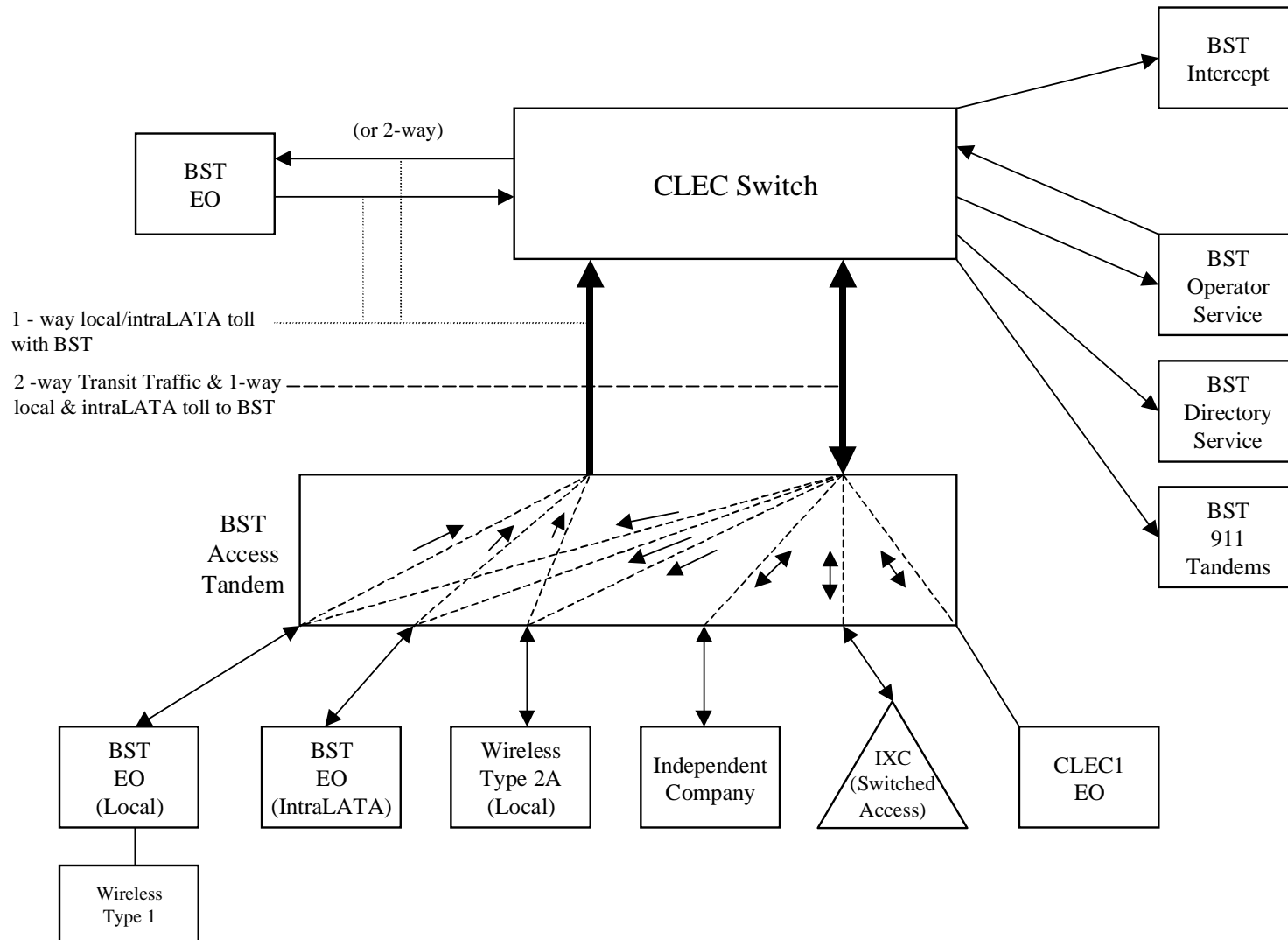

One-Way Architecture

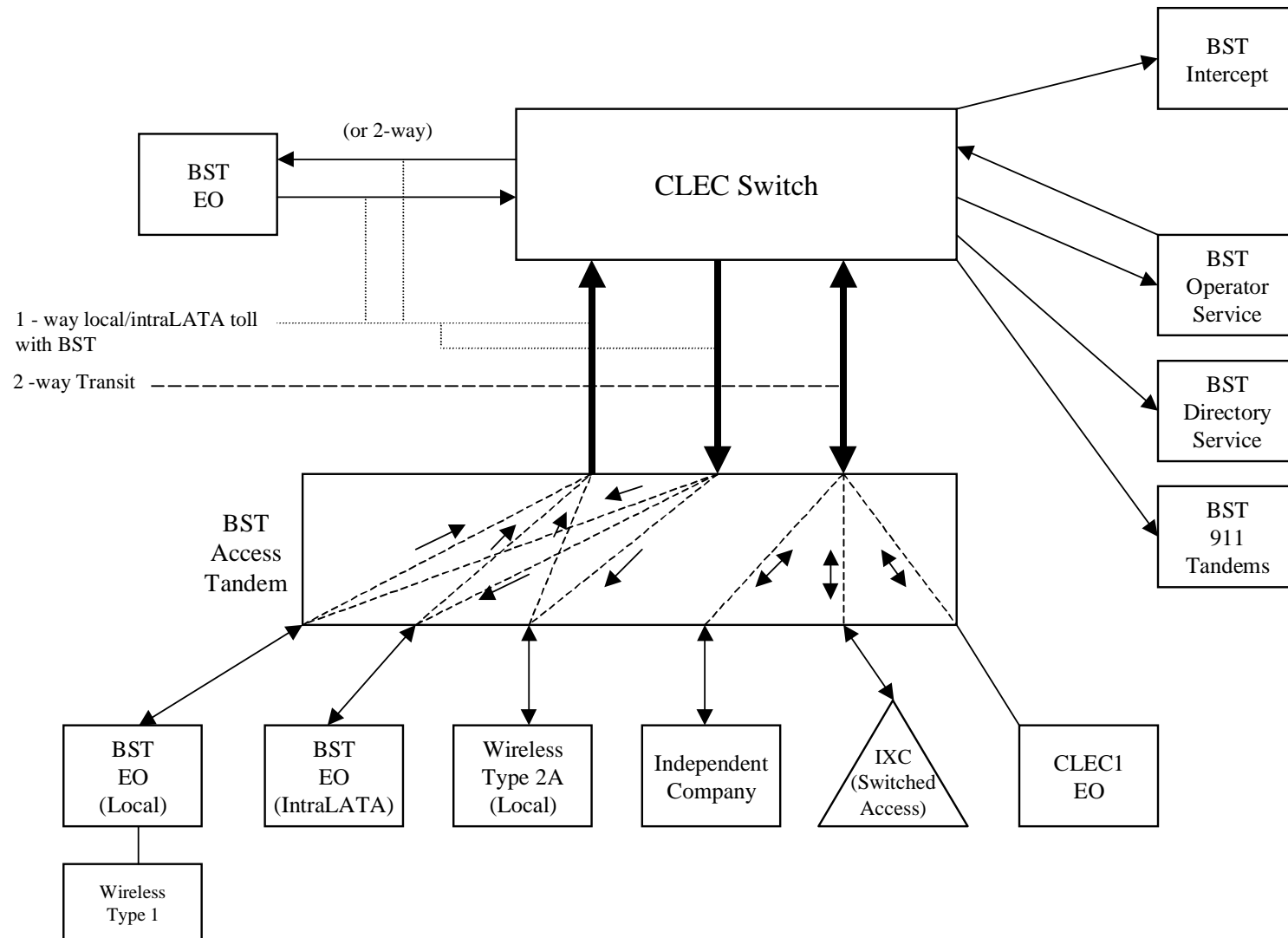

Exhibit D

Two-Way Architecture

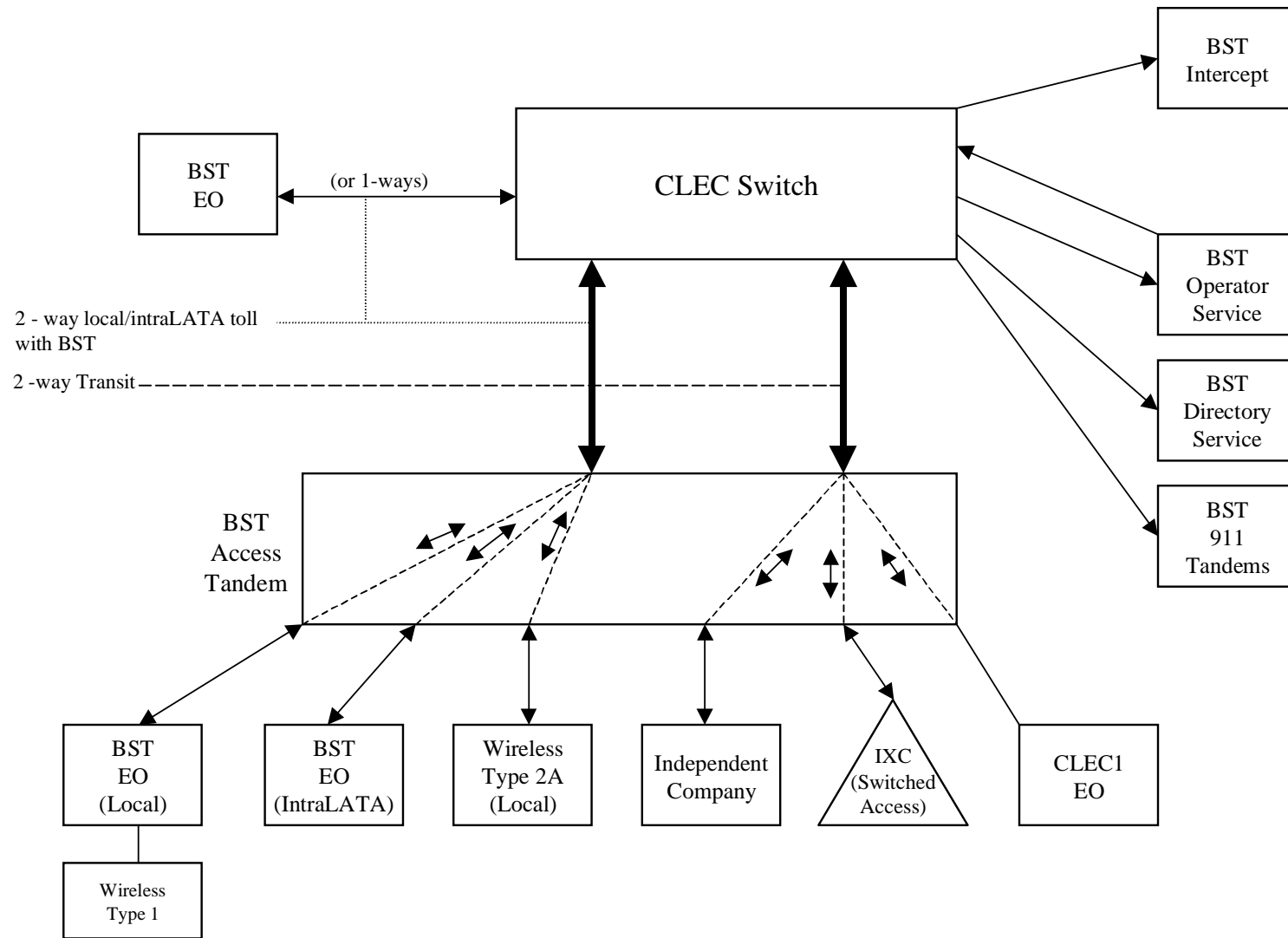
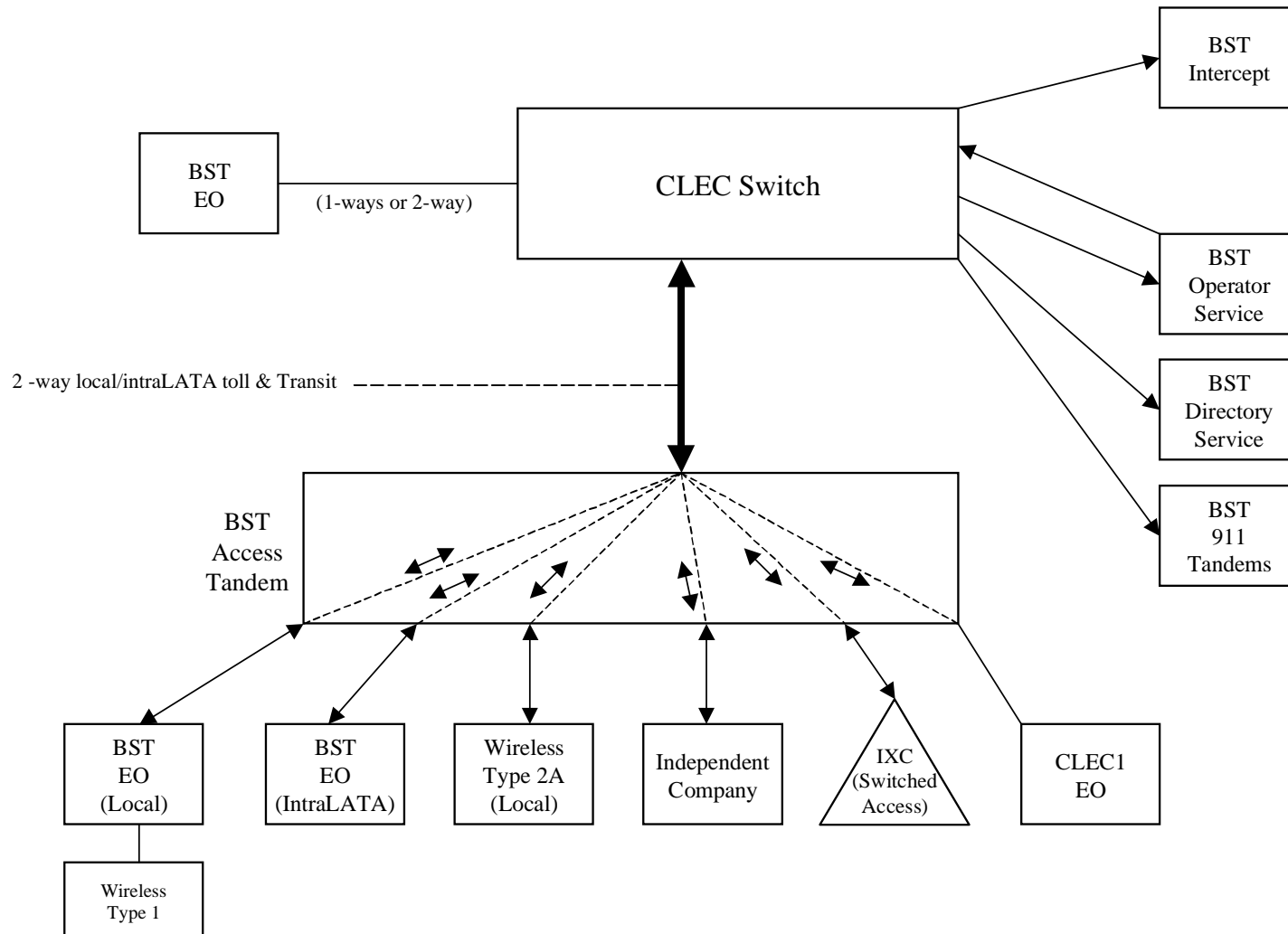

Exhibit E

Supergroup Architecture



LOCAL INTERCONNECTION - Alabama							Svc Order Submitted Elec per LSR	Svc Order Submitted Manually per LSR	Attachment: 3		Exhibit: A												
CATEGORY	RATE ELEMENTS	Interim	Zone	BCS	USOC	RATES (\$)	Rec	Nonrecurring		Nonrecurring Disconnect		OSS Rates (\$)											
								First	Add'l	First	Add'l	SOMEc	SOMAN	SOMAN	SOMAN	SOMAN	SOMAN						
LOCAL INTERCONNECTION (CALL TRANSPORT AND TERMINATION)																							
NOTE: "bk" beside a rate indicates that the Parties have agreed to bill and keep for that element pursuant to the terms and conditions in Attachment 3.																							
TANDEM SWITCHING																							
	Tandem Switching Function Per MOU			OHD		0.0004980bk																	
	Multiple Tandem Switching, per MOU (applies to intial tandem only)			OHD		0.000498																	
	Tandem Intermediary Charge, per MOU*			OHD		0.0025																	
* This charge is applicable only to transit traffic and is applied in addition to applicable switching and/or interconnection charges.																							
TRUNK CHARGE																							
	Installation Trunk Side Service - per DS0			OHD	TPP6X			21.56	8.12														
	Installation Trunk Side Service - per DS0			OHD	TPP9X			21.56	8.12														
	Dedicated End Office Trunk Port Service-per DS0**			OHD	TDEOP	0.00																	
	Dedicated End Office Trunk Port Service-per DS1**			OH1	OH1MS	TDE1P	0.00																
	Dedicated Tandem Trunk Port Service-per DS0**			OHD	TDWOP	0.00																	
	Dedicated Tandem Trunk Port Service-per DS1**			OH1	OH1MS	TDW1P	0.00																
** This rate element is recovered on a per MOU basis and is included in the End Office Switching and Tandem Switching, per MOU rate elements																							
COMMON TRANSPORT (Shared)																							
	Common Transport - Per Mile, Per MOU			OHD		0.0000023bk																	
	Common Transport - Facilities Termination Per MOU			OHD		0.0003224bk																	
LOCAL INTERCONNECTION (DEDICATED TRANSPORT)																							
INTEROFFICE CHANNEL - DEDICATED TRANSPORT																							
	Interoffice Channel - Dedicated Transport - 2-Wire Voice Grade - Per Mile per month			OHM	1L5NF	0.008838																	
	Interoffice Channel - Dedicated Transport- 2- Wire Voice Grade - Facility Termination per month			OHM	1L5NF	21.13		40.54	27.41	16.74	6.90												
	Interoffice Channel - Dedicated Transport - 56 kbps - per mile per month			OHM	1L5NK	0.008838																	
	Interoffice Channel - Dedicated Transport - 56 kbps - Facility Termination per month			OHM	1L5NK	15.12		40.54	27.41	16.74	6.90												
	Interoffice Channel - Dedicated Transport - 64 kbps - per mile per month			OHM	1L5NK	0.008838																	
	Interoffice Channel - Dedicated Transport - 64 kbps - Facility Termination per month			OHM	1L5NK	15.12		40.54	27.41	16.74	6.90												
	Interoffice Channel - Dedicated Channel - DS1 - Per Mile per month			OH1, OH1MS	1L5NL	0.18																	
	Interoffice Channel - Dedicated Transport - DS1 - Facility Termination per month			OH1, OH1MS	1L5NL	60.16		89.27	81.81	16.35	14.44												
	Interoffice Channel - Dedicated Transport - DS3 - Per Mile per month			OH3, OH3MS	1L5NM	4.09																	
	Interoffice Channel - Dedicated Transport - DS3 - Facility Termination per month			OH3, OH3MS	1L5NM	703.52		278.75	162.76	60.20	58.46												
LOCAL CHANNEL - DEDICATED TRANSPORT																							
	Local Channel - Dedicated - 2-Wire Voice Grade per month			OHM	TEFV2	13.97		193.10	33.17	36.64	3.20												
	Local Channel - Dedicated - 4-Wire Voice Grade per month			OHM	TEFV4	14.93		193.53	33.60	37.11	3.67												
	Local Channel - Dedicated - DS1 per month			OH1	TEFHG	35.76		177.47	153.72	22.19	15.26												
	Local Channel - Dedicated - DS3 Facility Termination per month			OH3	TEFHJ	416.54		451.52	263.94	119.49	83.58												
LOCAL INTERCONNECTION MID-SPAN MEET																							
NOTE: If Access service ride Mid-Span Meet, one-half the tariffed service Local Channel rate is applicable.																							
	Local Channel - Dedicated - DS1 per month			OH1MS	TEFHG	0.00		0.00															
	Local Channel - Dedicated - DS3 per month			OH3MS	TEFHJ	0.00		0.00															
MULTIPLEXERS																							
	Channelization - DS1 to DS0 Channel System			OH1, OH1MS	SATN1	101.06		91.04	62.57	10.54	9.79												
	DS3 to DS1 Channel System per month			OH3, OH3MS	SATNS	166.13		178.14	93.97	33.26	31.63												
	DS3 Interface Unit (DS1 COC) per month			OH1, OH1MS	SATCO	12.70		6.58	4.72														
Notes: If no rate is identified in the contract, the rates, terms, and conditions for the specific service or function will be as set forth in applicable BellSouth tariff.																							

LOCAL INTERCONNECTION - Florida							Svc Order Submitted Elec per LSR	Svc Order Submitted Manually per LSR	Attachment: 3		Exhibit: A										
CATEGORY	RATE ELEMENTS	Interim	Zone	BCS	USOC	RATES (\$)	Rec	Nonrecurring		Nonrecurring Disconnect		OSS Rates (\$)									
								First	Add'l	First	Add'l	SOMEc	SOMAN	SOMAN	SOMAN	SOMAN	SOMAN				
LOCAL INTERCONNECTION (CALL TRANSPORT AND TERMINATION)																					
NOTE: "bk" beside a rate indicates that the Parties have agreed to bill and keep for that element pursuant to the terms and conditions in Attachment 3.																					
TANDEM SWITCHING																					
	Tandem Switching Function Per MOU			OHD		0.0006019bk															
	Multiple Tandem Switching, per MOU (applies to intial tandem only)			OHD		0.0006019															
	Tandem Intermediary Charge, per MOU*			OHD		0.0025															
* This charge is applicable only to transit traffic and is applied in addition to applicable switching and/or interconnection charges.																					
TRUNK CHARGE																					
	Installation Trunk Side Service - per DS0			OHD	TPP6X			21.73	8.19												
	Installation Trunk Side Service - per DS0			OHD	TPP9X			21.73	8.19												
	Dedicated End Office Trunk Port Service-per DS0**			OHD	TDEOP	0.00															
	Dedicated End Office Trunk Port Service-per DS1**			OH1	OH1MS	TDE1P	0.00														
	Dedicated Tandem Trunk Port Service-per DS0**			OHD	TDWOP	0.00															
	Dedicated Tandem Trunk Port Service-per DS1**			OH1	OH1MS	TDW1P	0.00														
** This rate element is recovered on a per MOU basis and is included in the End Office Switching and Tandem Switching, per MOU rate elements																					
COMMON TRANSPORT (Shared)																					
	Common Transport - Per Mile, Per MOU			OHD		0.0000035bk															
	Common Transport - Facilities Termination Per MOU			OHD		0.0004372bk															
LOCAL INTERCONNECTION (DEDICATED TRANSPORT)																					
INTEROFFICE CHANNEL - DEDICATED TRANSPORT																					
	Interoffice Channel - Dedicated Transport - 2-Wire Voice Grade - Per Mile per month			OHM	1L5NF	0.0091															
	Interoffice Channel - Dedicated Transport- 2- Wire Voice Grade - Facility Termination per month			OHM	1L5NF	25.32		47.35	31.78	18.31	7.03										
	Interoffice Channel - Dedicated Transport - 56 kbps - per mile per month			OHM	1L5NK	0.0091															
	Interoffice Channel - Dedicated Transport - 56 kbps - Facility Termination per month			OHM	1L5NK	18.44		47.35	31.78	18.31	7.03										
	Interoffice Channel - Dedicated Transport - 64 kbps - per mile per month			OHM	1L5NK	0.0091															
	Interoffice Channel - Dedicated Transport - 64 kbps - Facility Termination per month			OHM	1L5NK	18.44		47.35	31.78	18.31	7.03										
	Interoffice Channel - Dedicated Channel - DS1 - Per Mile per month			OH1, OH1MS	1L5NL	0.1856															
	Interoffice Channel - Dedicated Transport - DS1 - Facility Termination per month			OH1, OH1MS	1L5NL	88.44		105.54	98.47	21.47	19.05										
	Interoffice Channel - Dedicated Transport - DS3 - Per Mile per month			OH3, OH3MS	1L5NM	3.87															
	Interoffice Channel - Dedicated Transport - DS3 - Facility Termination per month			OH3, OH3MS	1L5NM	1,071.00		335.46	219.28	72.03	70.56										
LOCAL CHANNEL - DEDICATED TRANSPORT																					
	Local Channel - Dedicated - 2-Wire Voice Grade per month			OHM	TEFV2	19.66		265.84	46.97	37.63	4.00										
	Local Channel - Dedicated - 4-Wire Voice Grade per month			OHM	TEFV4	20.45		266.54	47.67	44.22	5.33										
	Local Channel - Dedicated - DS1 per month			OH1	TEFHG	36.49		216.65	183.54	24.30	16.95										
	Local Channel - Dedicated - DS3 Facility Termination per month			OH3	TEFHJ	531.91		556.37	343.01	139.13	96.84										
LOCAL INTERCONNECTION MID-SPAN MEET																					
NOTE: If Access service ride Mid-Span Meet, one-half the tariffed service Local Channel rate is applicable.																					
	Local Channel - Dedicated - DS1 per month			OH1MS	TEFHG	0.00		0.00													
	Local Channel - Dedicated - DS3 per month			OH3MS	TEFHJ	0.00		0.00													
MULTIPLEXERS																					
	Channelization - DS1 to DS0 Channel System			OH1, OH1MS	SATN1	146.77		101.42	71.62	11.09	10.49										
	DS3 to DS1 Channel System per month			OH3, OH3MS	SATNS	211.19		199.28	118.64	40.34	39.07										
	DS3 Interface Unit (DS1 COC) per month			OH1, OH1MS	SATCO	13.76		10.07	7.08												
Notes: If no rate is identified in the contract, the rates, terms, and conditions for the specific service or function will be as set forth in applicable BellSouth tariff.																					

LOCAL INTERCONNECTION - Georgia							Svc Order Submitted Elec per LSR	Svc Order Submitted Manually per LSR	Attachment: 3		Exhibit: A													
CATEGORY	RATE ELEMENTS	Interim	Zone	BCS	USOC	RATES (\$)	Rec	Nonrecurring		Nonrecurring Disconnect		OSS Rates (\$)												
								First	Add'l	First	Add'l	SOMEK	SOMAN	SOMAN	SOMAN	SOMAN	SOMAN							
LOCAL INTERCONNECTION (CALL TRANSPORT AND TERMINATION)																								
NOTE: "bk" beside a rate indicates that the Parties have agreed to bill and keep for that element pursuant to the terms and conditions in Attachment 3.																								
TANDEM SWITCHING																								
	Tandem Switching Function Per MOU			OHD		0.0004086bk																		
	Multiple Tandem Switching, per MOU (applies to intial tandem only)			OHD		0.0004086																		
	Tandem Intermediary Charge, per MOU*			OHD		0.0025																		
* This charge is applicable only to transit traffic and is applied in addition to applicable switching and/or interconnection charges.																								
TRUNK CHARGE																								
	Installation Trunk Side Service - per DS0			OHD	TPP6X			21.53	8.11															
	Installation Trunk Side Service - per DS0			OHD	TPP9X			21.53	8.11															
	Dedicated End Office Trunk Port Service-per DS0**			OHD	TDEOP	0.00																		
	Dedicated End Office Trunk Port Service-per DS1**			OH1 OH1MS	TDE1P	0.00																		
	Dedicated Tandem Trunk Port Service-per DS0**			OHD	TDWOP	0.00																		
	Dedicated Tandem Trunk Port Service-per DS1**			OH1 OH1MS	TDW1P	0.00																		
** This rate element is recovered on a per MOU basis and is included in the End Office Switching and Tandem Switching, per MOU rate elements																								
COMMON TRANSPORT (Shared)																								
	Common Transport - Per Mile, Per MOU			OHD		0.0000027bk																		
	Common Transport - Facilities Termination Per MOU			OHD		0.0001914bk																		
LOCAL INTERCONNECTION (DEDICATED TRANSPORT)																								
INTEROFFICE CHANNEL - DEDICATED TRANSPORT																								
	Interoffice Channel - Dedicated Transport - 2-Wire Voice Grade - Per Mile per month			OHM	1L5NF	0.0057																		
	Interoffice Channel - Dedicated Transport- 2- Wire Voice Grade - Facility Termination per month			OHM	1L5NF	12.87		48.455	19.48	16.575	4.995													
	Interoffice Channel - Dedicated Transport - 56 kbps - per mile per month			OHM	1L5NK	0.0057																		
	Interoffice Channel - Dedicated Transport - 56 kbps - Facility Termination per month			OHM	1L5NK	7.83		48.455	19.48	16.575	4.995													
	Interoffice Channel - Dedicated Transport - 64 kbps - per mile per month			OHM	1L5NK	0.0057																		
	Interoffice Channel - Dedicated Transport - 64 kbps - Facility Termination per month			OHM	1L5NK	7.83		48.455	19.48	16.575	4.995													
	Interoffice Channel - Dedicated Channel - DS1 - Per Mile per month			OH1, OH1MS	1L5NL	0.1154																		
	Interoffice Channel - Dedicated Transport - DS1 - Facility Termination per month			OH1, OH1MS	1L5NL	34.19		111.025	80.28	31.355	21.73													
	Interoffice Channel - Dedicated Transport - DS3 - Per Mile per month			OH3, OH3MS	1L5NM	2.53																		
	Interoffice Channel - Dedicated Transport - DS3 - Facility Termination per month			OH3, OH3MS	1L5NM	342.02		320.47	86.32	66.77	52.81													
LOCAL CHANNEL - DEDICATED TRANSPORT																								
	Local Channel - Dedicated - 2-Wire Voice Grade per month			OHM	TEFV2	7.74		121.065	53.295	46.395	13.365													
	Local Channel - Dedicated - 4-Wire Voice Grade per month			OHM	TEFV4	8.72		125.62	54.43	46.395	13.365													
	Local Channel - Dedicated - DS1 per month			OH1	TEFHG	18.47		149.46	111.195	40.355	26.115													
	Local Channel - Dedicated - DS3 Facility Termination per month			OH3	TEFHJ	147.01		445.01	145.18	112.905	75.88													
LOCAL INTERCONNECTION MID-SPAN MEET																								
NOTE: If Access service ride Mid-Span Meet, one-half the tariffed service Local Channel rate is applicable.																								
	Local Channel - Dedicated - DS1 per month			OH1MS	TEFHG	0.00		0.00																
	Local Channel - Dedicated - DS3 per month			OH3MS	TEFHJ	0.00		0.00																
MULTIPLEXERS																								
	Channelization - DS1 to DS0 Channel System			OH1, OH1MS	SATN1	69.75		105.675	41.585	23.75	4.19													
	DS3 to DS1 Channel System per month			OH3, OH3MS	SATNS	121.90		224.475	71.83	40.005	31.065													
	DS3 Interface Unit (DS1 COC) per month			OH1, OH1MS	SATCO	7.35		15.805	11.385	6.605	6.605													
Notes: If no rate is identified in the contract, the rates, terms, and conditions for the specific service or function will be as set forth in applicable BellSouth tariff.																								

LOCAL INTERCONNECTION - Kentucky							Svc Order Submitted Elec per LSR	Svc Order Submitted Manually per LSR	Attachment: 3		Exhibit: A								
CATEGORY	RATE ELEMENTS	Interim	Zone	BCS	USOC	RATES (\$)	Rec	Nonrecurring		Nonrecurring Disconnect		OSS Rates (\$)							
								First	Add'l	First	Add'l	SOMEC	SOMAN	SOMAN	SOMAN	SOMAN	SOMAN		
LOCAL INTERCONNECTION (CALL TRANSPORT AND TERMINATION)																			
NOTE: "bk" beside a rate indicates that the Parties have agreed to bill and keep for that element pursuant to the terms and conditions in Attachment 3.																			
TANDEM SWITCHING																			
	Tandem Switching Function Per MOU			OHD		0.0006772bk													
	Multiple Tandem Switching, per MOU (applies to intial tandem only)			OHD		0.0006772													
	Tandem Intermediary Charge, per MOU*			OHD		0.0025													
* This charge is applicable only to transit traffic and is applied in addition to applicable switching and/or interconnection charges.																			
TRUNK CHARGE																			
	Installation Trunk Side Service - per DS0			OHD	TPP6X			21.58	8.13										
	Installation Trunk Side Service - per DS0			OHD	TPP9X			21.58	8.13										
	Dedicated End Office Trunk Port Service-per DS0**			OHD	TDEOP	0.00													
	Dedicated End Office Trunk Port Service-per DS1**			OH1 OH1MS	TDE1P	0.00													
	Dedicated Tandem Trunk Port Service-per DS0**			OHD	TDWOP	0.00													
	Dedicated Tandem Trunk Port Service-per DS1**			OH1 OH1MS	TDW1P	0.00													
** This rate element is recovered on a per MOU basis and is included in the End Office Switching and Tandem Switching, per MOU rate elements																			
COMMON TRANSPORT (Shared)																			
	Common Transport - Per Mile, Per MOU			OHD		0.0000030bk													
	Common Transport - Facilities Termination Per MOU			OHD		0.0007466bk													
LOCAL INTERCONNECTION (DEDICATED TRANSPORT)																			
INTEROFFICE CHANNEL - DEDICATED TRANSPORT																			
	Interoffice Channel - Dedicated Transport - 2-Wire Voice Grade - Per Mile per month			OHM	1L5NF	0.01													
	Interoffice Channel - Dedicated Transport- 2- Wire Voice Grade - Facility Termination per month			OHM	1L5NF	29.11		47.34	31.78	22.77	8.75								
	Interoffice Channel - Dedicated Transport - 56 kbps - per mile per month			OHM	1L5NK	0.0115													
	Interoffice Channel - Dedicated Transport - 56 kbps - Facility Termination per month			OHM	1L5NK	20.97		47.35	31.78	22.77	8.75								
	Interoffice Channel - Dedicated Transport - 64 kbps - per mile per month			OHM	1L5NK	0.0115													
	Interoffice Channel - Dedicated Transport - 64 kbps - Facility Termination per month			OHM	1L5NK	20.97		47.35	31.78	22.77	8.75								
	Interoffice Channel - Dedicated Channel - DS1 - Per Mile per month			OH1, OH1MS	1L5NL	0.23													
	Interoffice Channel - Dedicated Transport - DS1 - Facility Termination per month			OH1, OH1MS	1L5NL	96.04		105.52	98.46	23.09	20.49								
	Interoffice Channel - Dedicated Transport - DS3 - Per Mile per month			OH3, OH3MS	1L5NM	4.97													
	Interoffice Channel - Dedicated Transport - DS3 - Facility Termination per month			OH3, OH3MS	1L5NM	1,175.15		335.40	219.24	89.57	87.75								
LOCAL CHANNEL - DEDICATED TRANSPORT																			
	Local Channel - Dedicated - 2-Wire Voice Grade per month			OHM	TEFV2	18.57		265.78	46.96	46.79	4.98								
	Local Channel - Dedicated - 4-Wire Voice Grade per month			OHM	TEFV4	19.86		266.48	47.65	47.54	5.73								
	Local Channel - Dedicated - DS1 per month			OH1	TEFHG	40.46		209.60	176.51	30.21	21.07								
	Local Channel - Dedicated - DS3 Facility Termination per month			OH3	TEFHJ	576.05		551.38	338.08	173.00	120.42								
LOCAL INTERCONNECTION MID-SPAN MEET																			
NOTE: If Access service ride Mid-Span Meet, one-half the tariffed service Local Channel rate is applicable.																			
	Local Channel - Dedicated - DS1 per month			OH1MS	TEFHG	0.00		0.00											
	Local Channel - Dedicated - DS3 per month			OH3MS	TEFHJ	0.00		0.00											
MULTIPLEXERS																			
	Channelization - DS1 to DS0 Channel System			OH1, OH1MS	SATN1	113.33		101.40	71.60	13.79	13.04								
	DS3 to DS1 Channel System per month			OH3, OH3MS	SATNS	158.20		199.23	118.62	50.16	48.59								
	DS3 Interface Unit (DS1 COCI) per month			OH1, OH1MS	SATCO	11.80		10.07	7.08										
Notes: If no rate is identified in the contract, the rates, terms, and conditions for the specific service or function will be as set forth in applicable BellSouth tariff.																			

LOCAL INTERCONNECTION - Louisiana							Svc Order Submitted Elec per LSR	Svc Order Submitted Manually per LSR	Attachment: 3		Exhibit: A									
CATEGORY	RATE ELEMENTS	Interim	Zone	BCS	USOC	RATES (\$)	Rec	Nonrecurring		Nonrecurring Disconnect		OSS Rates (\$)								
								First	Add'l	First	Add'l	SOMEC	SOMAN	SOMAN	SOMAN	SOMAN	SOMAN			
LOCAL INTERCONNECTION (CALL TRANSPORT AND TERMINATION)																				
NOTE: "bk" beside a rate indicates that the Parties have agreed to bill and keep for that element pursuant to the terms and conditions in Attachment 3.																				
TANDEM SWITCHING																				
	Tandem Switching Function Per MOU			OHD		0.0005507bk														
	Multiple Tandem Switching, per MOU (applies to intial tandem only)			OHD		0.0005507														
	Tandem Intermediary Charge, per MOU*			OHD		0.0025														
* This charge is applicable only to transit traffic and is applied in addition to applicable switching and/or interconnection charges.																				
TRUNK CHARGE																				
	Installation Trunk Side Service - per DS0			OHD	TPP6X			21.64	8.15											
	Installation Trunk Side Service - per DS0			OHD	TPP9X			21.64	8.15											
	Dedicated End Office Trunk Port Service-per DS0**			OHD	TDEOP	0.00														
	Dedicated End Office Trunk Port Service-per DS1**			OH1 OH1MS	TDE1P	0.00														
	Dedicated Tandem Trunk Port Service-per DS0**			OHD	TDWOP	0.00														
	Dedicated Tandem Trunk Port Service-per DS1**			OH1 OH1MS	TDW1P	0.00														
** This rate element is recovered on a per MOU basis and is included in the End Office Switching and Tandem Switching, per MOU rate elements																				
COMMON TRANSPORT (Shared)																				
	Common Transport - Per Mile, Per MOU			OHD		0.0000032bk														
	Common Transport - Facilities Termination Per MOU			OHD		0.0003748bk														
LOCAL INTERCONNECTION (DEDICATED TRANSPORT)																				
INTEROFFICE CHANNEL - DEDICATED TRANSPORT																				
	Interoffice Channel - Dedicated Transport - 2-Wire Voice Grade - Per Mile per month			OHM	1L5NF	0.013														
	Interoffice Channel - Dedicated Transport- 2- Wire Voice Grade - Facility Termination per month			OHM	1L5NF	22.60		39.36	26.62											
	Interoffice Channel - Dedicated Transport - 56 kbps - per mile per month			OHM	1L5NK	0.013														
	Interoffice Channel - Dedicated Transport - 56 kbps - Facility Termination per month			OHM	1L5NK	15.61		39.37	26.62											
	Interoffice Channel - Dedicated Transport - 64 kbps - per mile per month			OHM	1L5NK	0.013														
	Interoffice Channel - Dedicated Transport - 64 kbps - Facility Termination per month			OHM	1L5NK	15.61		39.37	26.62											
	Interoffice Channel - Dedicated Channel - DS1 - Per Mile per month			OH1, OH1MS	1L5NL	0.2652														
	Interoffice Channel - Dedicated Transport - DS1 - Facility Termination per month			OH1, OH1MS	1L5NL	70.47		86.69	79.44											
	Interoffice Channel - Dedicated Transport - DS3 - Per Mile per month			OH3, OH3MS	1L5NM	6.04														
	Interoffice Channel - Dedicated Transport - DS3 - Facility Termination per month			OH3, OH3MS	1L5NM	850.45		270.69	158.05											
LOCAL CHANNEL - DEDICATED TRANSPORT																				
	Local Channel - Dedicated - 2-Wire Voice Grade per month			OHM	TEFV2	18.32		187.51	32.21											
	Local Channel - Dedicated - 4-Wire Voice Grade per month			OHM	TEFV4	19.41		187.94	32.63											
	Local Channel - Dedicated - DS1 per month			OH1	TEFHG	39.18		172.34	149.27											
	Local Channel - Dedicated - DS3 Facility Termination per month			OH3	TEFHJ	469.44		438.46	256.30											
LOCAL INTERCONNECTION MID-SPAN MEET																				
NOTE: If Access service ride Mid-Span Meet, one-half the tariffed service Local Channel rate is applicable.																				
	Local Channel - Dedicated - DS1 per month			OH1MS	TEFHG	0.00		0.00												
	Local Channel - Dedicated - DS3 per month			OH3MS	TEFHJ	0.00		0.00												
MULTIPLEXERS																				
	Channelization - DS1 to DS0 Channel System			OH1, OH1MS	SATN1	105.09		88.41	60.76											
	DS3 to DS1 Channel System per month			OH3, OH3MS	SATNS	201.48		172.99	91.25											
	DS3 Interface Unit (DS1 COC) per month			OH1, OH1MS	SATCO	11.78		6.39	4.58											
Notes: If no rate is identified in the contract, the rates, terms, and conditions for the specific service or function will be as set forth in applicable BellSouth tariff.																				

LOCAL INTERCONNECTION - Mississippi							Svc Order Submitted Elec per LSR	Svc Order Submitted Manually per LSR	Attachment: 3		Exhibit: A								
CATEGORY	RATE ELEMENTS	Interim	Zone	BCS	USOC	RATES (\$)	Rec	Nonrecurring		Nonrecurring Disconnect		OSS Rates (\$)							
								First	Add'l	First	Add'l	SOMEK	SOMAN	SOMAN	SOMAN	SOMAN	SOMAN		
LOCAL INTERCONNECTION (CALL TRANSPORT AND TERMINATION)																			
NOTE: "bk" beside a rate indicates that the Parties have agreed to bill and keep for that element pursuant to the terms and conditions in Attachment 3.																			
TANDEM SWITCHING																			
	Tandem Switching Function Per MOU			OHD		0.0005379bk													
	Multiple Tandem Switching, per MOU (applies to intial tandem only)			OHD		0.0005379													
	Tandem Intermediary Charge, per MOU*			OHD		0.0025													
* This charge is applicable only to transit traffic and is applied in addition to applicable switching and/or interconnection charges.																			
TRUNK CHARGE																			
	Installation Trunk Side Service - per DS0			OHD	TPP6X			21.58	8.13										
	Installation Trunk Side Service - per DS0			OHD	TPP9X			21.58	8.13										
	Dedicated End Office Trunk Port Service-per DS0**			OHD	TDEOP	0.00													
	Dedicated End Office Trunk Port Service-per DS1**			OH1 OH1MS	TDE1P	0.00													
	Dedicated Tandem Trunk Port Service-per DS0**			OHD	TDWOP	0.00													
	Dedicated Tandem Trunk Port Service-per DS1**			OH1 OH1MS	TDW1P	0.00													
** This rate element is recovered on a per MOU basis and is included in the End Office Switching and Tandem Switching, per MOU rate elements																			
COMMON TRANSPORT (Shared)																			
	Common Transport - Per Mile, Per MOU			OHD		0.0000026bk													
	Common Transport - Facilities Termination Per MOU			OHD		0.0004541bk													
LOCAL INTERCONNECTION (DEDICATED TRANSPORT)																			
INTEROFFICE CHANNEL - DEDICATED TRANSPORT																			
	Interoffice Channel - Dedicated Transport - 2-Wire Voice Grade - Per Mile per month			OHM	1L5NF	0.0098													
	Interoffice Channel - Dedicated Transport- 2- Wire Voice Grade - Facility Termination per month			OHM	1L5NF	22.52		40.77	27.57	17.26	7.11								
	Interoffice Channel - Dedicated Transport - 56 kbps - per mile per month			OHM	1L5NK	0.0098													
	Interoffice Channel - Dedicated Transport - 56 kbps - Facility Termination per month			OHM	1L5NK	15.68		40.78	27.57	17.26	7.11								
	Interoffice Channel - Dedicated Transport - 64 kbps - per mile per month			OHM	1L5NK	0.0098													
	Interoffice Channel - Dedicated Transport - 64 kbps - Facility Termination per month			OHM	1L5NK	15.68		40.78	27.57	17.26	7.11								
	Interoffice Channel - Dedicated Channel - DS1 - Per Mile per month			OH1, OH1MS	1L5NL	0.201													
	Interoffice Channel - Dedicated Transport - DS1 - Facility Termination per month			OH1, OH1MS	1L5NL	57.33		89.79	82.28	16.86	14.90								
	Interoffice Channel - Dedicated Transport - DS3 - Per Mile per month			OH3, OH3MS	1L5NM	4.76													
	Interoffice Channel - Dedicated Transport - DS3 - Facility Termination per month			OH3, OH3MS	1L5NM	641.90		280.37	163.70	62.08	60.29								
LOCAL CHANNEL - DEDICATED TRANSPORT																			
	Local Channel - Dedicated - 2-Wire Voice Grade per month			OHM	TEFV2	14.91		194.22	33.36	37.79	3.30								
	Local Channel - Dedicated - 4-Wire Voice Grade per month			OHM	TEFV4	15.99		194.66	33.80	38.27	3.78								
	Local Channel - Dedicated - DS1 per month			OH1	TEFHG	36.83		178.50	154.61	22.89	15.74								
	Local Channel - Dedicated - DS3 Facility Termination per month			OH3	TEFHJ	413.87		454.13	264.47	123.23	86.19								
LOCAL INTERCONNECTION MID-SPAN MEET																			
NOTE: If Access service ride Mid-Span Meet, one-half the tariffed service Local Channel rate is applicable.																			
	Local Channel - Dedicated - DS1 per month			OH1MS	TEFHG	0.00		0.00											
	Local Channel - Dedicated - DS3 per month			OH3MS	TEFHJ	0.00		0.00											
MULTIPLEXERS																			
	Channelization - DS1 to DS0 Channel System			OH1, OH1MS	SATN1	102.85		91.57	62.94	10.87	10.10								
	DS3 to DS1 Channel System per month			OH3, OH3MS	SATNS	170.63		179.17	94.52	34.30	32.82								
	DS3 Interface Unit (DS1 COC) per month			OH1, OH1MS	SATCO	12.96		6.62	4.74										
Notes: If no rate is identified in the contract, the rates, terms, and conditions for the specific service or function will be as set forth in applicable BellSouth tariff.																			

LOCAL INTERCONNECTION - North Carolina							Svc Order Submitted Elec per LSR	Svc Order Submitted Manually per LSR	Attachment: 3		Exhibit: A											
CATEGORY	RATE ELEMENTS	Interim	Zone	BCS	USOC	RATES (\$)	Rec	Nonrecurring		Nonrecurring Disconnect		OSS Rates (\$)										
								First	Add'l	First	Add'l	SOMEC	SOMAN	SOMAN	SOMAN	SOMAN	SOMAN					
LOCAL INTERCONNECTION (CALL TRANSPORT AND TERMINATION)																						
NOTE: "bk" beside a rate indicates that the Parties have agreed to bill and keep for that element pursuant to the terms and conditions in Attachment 3.																						
TANDEM SWITCHING																						
	Tandem Switching Function Per MOU			OHD		0.0012000bk																
	Multiple Tandem Switching, per MOU (applies to intial tandem only)			OHD		0.0012																
	Tandem Intermediary Charge, per MOU*			OHD		0.0025																
* This charge is applicable only to transit traffic and is applied in addition to applicable switching and/or interconnection charges.																						
TRUNK CHARGE																						
	Installation Trunk Side Service - per DS0			OHD	TPP6X			21.55	8.12													
	Installation Trunk Side Service - per DS0			OHD	TPP9X			21.55	8.12													
	Dedicated End Office Trunk Port Service-per DS0**			OHD	TDEOP	0.00																
	Dedicated End Office Trunk Port Service-per DS1**			OH1 OH1MS	TDE1P	0.00																
	Dedicated Tandem Trunk Port Service-per DS0**			OHD	TDWOP	0.00																
	Dedicated Tandem Trunk Port Service-per DS1**			OH1 OH1MS	TDW1P	0.00																
** This rate element is recovered on a per MOU basis and is included in the End Office Switching and Tandem Switching, per MOU rate elements																						
COMMON TRANSPORT (Shared)																						
	Common Transport - Per Mile, Per MOU			OHD		0.0000100bk																
	Common Transport - Facilities Termination Per MOU			OHD		0.0003400bk																
LOCAL INTERCONNECTION (DEDICATED TRANSPORT)																						
INTEROFFICE CHANNEL - DEDICATED TRANSPORT																						
	Interoffice Channel - Dedicated Transport - 2-Wire Voice Grade - Per Mile per month			OHM	1L5NF	0.0282																
	Interoffice Channel - Dedicated Transport- 2- Wire Voice Grade - Facility Termination per month			OHM	1L5NF	18.00		137.48	52.58													
	Interoffice Channel - Dedicated Transport - 56 kbps - per mile per month			OHM	1L5NK	0.0282																
	Interoffice Channel - Dedicated Transport - 56 kbps - Facility Termination per month			OHM	1L5NK	17.40		137.48	52.58													
	Interoffice Channel - Dedicated Transport - 64 kbps - per mile per month			OHM	1L5NK	0.0282																
	Interoffice Channel - Dedicated Transport - 64 kbps - Facility Termination per month			OHM	1L5NK	17.40		137.48	52.58													
	Interoffice Channel - Dedicated Channel - DS1 - Per Mile per month			OH1, OH1MS	1L5NL	0.5753																
	Interoffice Channel - Dedicated Transport - DS1 - Facility Termination per month			OH1, OH1MS	1L5NL	71.29		217.17	163.75													
	Interoffice Channel - Dedicated Transport - DS3 - Per Mile per month			OH3, OH3MS	1L5NM	12.98																
	Interoffice Channel - Dedicated Transport - DS3 - Facility Termination per month			OH3, OH3MS	1L5NM	720.38		794.94	579.55													
LOCAL CHANNEL - DEDICATED TRANSPORT																						
	Local Channel - Dedicated - 2-Wire Voice Grade per month			OHM	TEFV2	11.24		553.80	89.69													
	Local Channel - Dedicated - 4-Wire Voice Grade per month			OHM	TEFV4	12.03		562.23	92.67													
	Local Channel - Dedicated - DS1 per month			OH1	TEFHG	27.05		534.48	462.69													
	Local Channel - Dedicated - DS3 Facility Termination per month			OH3	TEFHJ	298.92		438.46	256.30													
LOCAL INTERCONNECTION MID-SPAN MEET																						
NOTE: If Access service ride Mid-Span Meet, one-half the tariffed service Local Channel rate is applicable.																						
	Local Channel - Dedicated - DS1 per month			OH1MS	TEFHG	0.00		0.00														
	Local Channel - Dedicated - DS3 per month			OH3MS	TEFHJ	0.00		0.00														
MULTIPLEXERS																						
	Channelization - DS1 to DS0 Channel System			OH1, OH1MS	SATN1	146.69		197.78	140.06													
	DS3 to DS1 Channel System per month			OH3, OH3MS	SATNS	233.10		403.97	234.40													
	DS3 Interface Unit (DS1 COC) per month			OH1, OH1MS	SATCO	16.07		13.09	9.38													
Notes: If no rate is identified in the contract, the rates, terms, and conditions for the specific service or function will be as set forth in applicable BellSouth tariff.																						

LOCAL INTERCONNECTION - South Carolina							Svc Order Submitted Elec per LSR	Svc Order Submitted Manually per LSR	Attachment: 3		Exhibit: A											
CATEGORY	RATE ELEMENTS	Interim	Zone	BCS	USOC	RATES (\$)	Rec	Nonrecurring		Nonrecurring Disconnect		OSS Rates (\$)										
								First	Add'l	First	Add'l	SOMEC	SOMAN	SOMAN	SOMAN	SOMAN	SOMAN					
LOCAL INTERCONNECTION (CALL TRANSPORT AND TERMINATION)																						
NOTE: "bk" beside a rate indicates that the Parties have agreed to bill and keep for that element pursuant to the terms and conditions in Attachment 3.																						
TANDEM SWITCHING																						
	Tandem Switching Function Per MOU			OHD		0.0007360bk																
	Multiple Tandem Switching, per MOU (applies to intial tandem only)			OHD		0.000736																
	Tandem Intermediary Charge, per MOU*			OHD		0.0025																
* This charge is applicable only to transit traffic and is applied in addition to applicable switching and/or interconnection charges.																						
TRUNK CHARGE																						
	Installation Trunk Side Service - per DS0			OHD	TPP6X			21.65	8.16													
	Installation Trunk Side Service - per DS0			OHD	TPP9X			21.65	8.16													
	Dedicated End Office Trunk Port Service-per DS0**			OHD	TDEOP	0.00																
	Dedicated End Office Trunk Port Service-per DS1**			OH1 OH1MS	TDE1P	0.00																
	Dedicated Tandem Trunk Port Service-per DS0**			OHD	TDWOP	0.00																
	Dedicated Tandem Trunk Port Service-per DS1**			OH1 OH1MS	TDW1P	0.00																
** This rate element is recovered on a per MOU basis and is included in the End Office Switching and Tandem Switching, per MOU rate elements																						
COMMON TRANSPORT (Shared)																						
	Common Transport - Per Mile, Per MOU			OHD		0.0000045bk																
	Common Transport - Facilities Termination Per MOU			OHD		0.0004095bk																
LOCAL INTERCONNECTION (DEDICATED TRANSPORT)																						
INTEROFFICE CHANNEL - DEDICATED TRANSPORT																						
	Interoffice Channel - Dedicated Transport - 2-Wire Voice Grade - Per Mile per month			OHM	1L5NF	0.0167																
	Interoffice Channel - Dedicated Transport- 2- Wire Voice Grade - Facility Termination per month			OHM	1L5NF	24.30		40.63	27.47	16.77	6.91											
	Interoffice Channel - Dedicated Transport - 56 kbps - per mile per month			OHM	1L5NK	0.0167																
	Interoffice Channel - Dedicated Transport - 56 kbps - Facility Termination per month			OHM	1L5NK	16.76		40.63	27.47	16.77	6.91											
	Interoffice Channel - Dedicated Transport - 64 kbps - per mile per month			OHM	1L5NK	0.0167																
	Interoffice Channel - Dedicated Transport - 64 kbps - Facility Termination per month			OHM	1L5NK	16.76		40.63	27.47	16.77	6.91											
	Interoffice Channel - Dedicated Channel - DS1 - Per Mile per month			OH1, OH1MS	1L5NL	0.3415																
	Interoffice Channel - Dedicated Transport - DS1 - Facility Termination per month			OH1, OH1MS	1L5NL	77.14		89.47	81.99	16.39	14.48											
	Interoffice Channel - Dedicated Transport - DS3 - Per Mile per month			OH3, OH3MS	1L5NM	8.02																
	Interoffice Channel - Dedicated Transport - DS3 - Facility Termination per month			OH3, OH3MS	1L5NM	880.65		279.37	163.12	60.33	58.59											
LOCAL CHANNEL - DEDICATED TRANSPORT																						
	Local Channel - Dedicated - 2-Wire Voice Grade per month			OHM	TEFV2	15.33		193.53	33.24	36.72	3.21											
	Local Channel - Dedicated - 4-Wire Voice Grade per month			OHM	TEFV4	16.54		193.97	33.68	37.19	3.68											
	Local Channel - Dedicated - DS1 per month			OH1	TEFHG	42.62		177.87	154.06	22.24	15.30											
	Local Channel - Dedicated - DS3 Facility Termination per month			OH3	TEFHJ	446.00		452.52	264.53	119.75	83.77											
LOCAL INTERCONNECTION MID-SPAN MEET																						
NOTE: If Access service ride Mid-Span Meet, one-half the tariffed service Local Channel rate is applicable.																						
	Local Channel - Dedicated - DS1 per month			OH1MS	TEFHG	0.00		0.00														
	Local Channel - Dedicated - DS3 per month			OH3MS	TEFHJ	0.00		0.00														
MULTIPLEXERS																						
	Channelization - DS1 to DS0 Channel System			OH1, OH1MS	SATN1	107.57		91.24	62.71	10.56	9.81											
	DS3 to DS1 Channel System per month			OH3, OH3MS	SATNS	144.02		178.54	94.18	33.33	31.90											
	DS3 Interface Unit (DS1 COCI) per month			OH1, OH1MS	SATCO	8.64		6.59	4.73													
Notes: If no rate is identified in the contract, the rates, terms, and conditions for the specific service or function will be as set forth in applicable BellSouth tariff.																						

LOCAL INTERCONNECTION - Tennessee										Attachment: 3		Exhibit: A			
CATEGORY	RATE ELEMENTS	Interim	Zone	BCS	USOC	RATES (\$)				Svc Order Submitted Elec per LSR	Svc Order Submitted Manually per LSR	Incremental Charge - Manual Svc Order vs. Electronic-1st	Incremental Charge - Manual Svc Order vs. Electronic-Add'l	Incremental Charge - Manual Svc Order vs. Electronic-Disc 1st	Incremental Charge - Manual Svc Order vs. Electronic-Disc Add'l
						Rec	Nonrecurring First	Add'l	Nonrecurring First						
										SOMEc	SOMAN	SOMAN	SOMAN	SOMAN	SOMAN
LOCAL INTERCONNECTION (CALL TRANSPORT AND TERMINATION)															
NOTE: "bk" beside a rate indicates that the Parties have agreed to bill and keep for that element pursuant to the terms and conditions in Attachment 3.															
TANDEM SWITCHING															
	Tandem Switching Function Per MOU			OHD		0.0009778bk									
	Multiple Tandem Switching, per MOU (applies to intial tandem only)			OHD		0.0009778									
	Tandem Intermediary Charge, per MOU*			OHD		0.0025									
* This charge is applicable only to transit traffic and is applied in addition to applicable switching and/or interconnection charges.															
TRUNK CHARGE															
	Installation Trunk Side Service - per DS0			OHD	TPP6X		21.59	8.09							
	Installation Trunk Side Service - per DS0			OHD	TPP9X		21.59	8.09							
	Dedicated End Office Trunk Port Service-per DS0**			OHD	TDEOP	0.00									
	Dedicated End Office Trunk Port Service-per DS1**			OH1 OH1MS	TDE1P	0.00									
	Dedicated Tandem Trunk Port Service-per DS0**			OHD	TDWOP	0.00									
	Dedicated Tandem Trunk Port Service-per DS1**			OH1 OH1MS	TDW1P	0.00									
** This rate element is recovered on a per MOU basis and is included in the End Office Switching and Tandem Switching, per MOU rate elements															
COMMON TRANSPORT (Shared)															
	Common Transport - Per Mile, Per MOU			OHD		0.0000064bk									
	Common Transport - Facilities Termination Per MOU			OHD		0.0003871bk									
LOCAL INTERCONNECTION (DEDICATED TRANSPORT)															
INTEROFFICE CHANNEL - DEDICATED TRANSPORT															
	Interoffice Channel - Dedicated Transport - 2-Wire Voice Grade - Per Mile per month			OHM	1L5NF	0.0174									
	Interoffice Channel - Dedicated Transport- 2- Wire Voice Grade - Facility Termination per month			OHM	1L5NF	18.58	55.39	17.37	27.96	3.51					
	Interoffice Channel - Dedicated Transport - 56 kbps - per mile per month			OHM	1L5NK	0.0174									
	Interoffice Channel - Dedicated Transport - 56 kbps - Facility Termination per month			OHM	1L5NK	17.98	55.39	17.37	27.96	3.51					
	Interoffice Channel - Dedicated Transport - 64 kbps - per mile per month			OHM	1L5NK	0.0174									
	Interoffice Channel - Dedicated Transport - 64 kbps - Facility Termination per month			OHM	1L5NK	17.98	55.39	17.37	27.96	3.51					
	Interoffice Channel - Dedicated Channel - DS1 - Per Mile per month			OH1, OH1MS	1L5NL	0.3562									
	Interoffice Channel - Dedicated Tranport - DS1 - Facility Termination per month			OH1, OH1MS	1L5NL	77.86	112.40	76.27	19.55	14.99					
	Interoffice Channel - Dedicated Transport - DS3 - Per Mile per month			OH3, OH3MS	1L5NM	2.34									
	Interoffice Channel - Dedicated Transport - DS3 - Facility Termination per month			OH3, OH3MS	1L5NM	848.99	395.29	176.56	109.04	105.91					
LOCAL CHANNEL - DEDICATED TRANSPORT															
	Local Channel - Dedicated - 2-Wire Voice Grade per month			OHM	TEFV2	19.43	199.33	24.16	54.81	4.80					
	Local Channel - Dedicated - 4-Wire Voice Grade per month			OHM	TEFV4	20.56	201.53	24.83	55.52	5.51					
	Local Channel - Dedicated - DS1 per month			OH1	TEFHG	40.99	277.35	233.26	33.18	22.30					
	Local Channel - Dedicated - DS3 Facility Termination per month			OH3	TEFHJ	611.30	595.37	304.50	215.82	151.15					
LOCAL INTERCONNECTION MID-SPAN MEET															
NOTE: If Access service ride Mid-Span Meet, one-half the tariffed service Local Channel rate is applicable.															
	Local Channel - Dedicated - DS1 per month			OH1MS	TEFHG	0.00	0.00								
	Local Channel - Dedicated - DS3 per month			OH3MS	TEFHJ	0.00	0.00								
MULTIPLEXERS															
	Channelization - DS1 to DS0 Channel System			OH1, OH1MS	SATN1	80.77	141.87	77.11	44.47	42.62					
	DS3 to DS1 Channel System per month			OH3, OH3MS	SATNS	222.98	308.03	108.47	6.34	4.23					
	DS3 Interface Unit (DS1 COC) per month			OH1, OH1MS	SATCO	17.58	6.07	4.66							
Notes: If no rate is identified in the contract, the rates, terms, and conditions for the specific service or function will be as set forth in applicable BellSouth tariff.															