

ORIGINAL

COMMONWEALTH OF KENTUCKY

RECEIVED

BEFORE THE PUBLIC SERVICE COMMISSION

FEB 27 2015

**PUBLIC SERVICE
COMMISSION**

In the Matter of:

**TARIFF FILING OF JESSAMINE-SOUTH)
ELKHORN WATER DISTRICT' TO)
IMPLEMENT CERTAIN NON-RECURRING)
CHARGES FOR THE PROVISION OF)
SEWER SERVICE)**

CASE NO. 2014-00377

**JSEWD'S RESPONSES TO COMMISSION STAFF'S FIRST
REQUESTS FOR INFORMATION**

Comes the Jessamine-South Elkhorn Water District ("JSEWD"), by counsel, and for its Responses to the First Set of Requests for Information from the Kentucky Public Service Commission ("PSC"), answers as follows:

RESPONSES FOLLOW ON NEXT PAGE

Jessamine-South Elkhorn Water District

Information Request No. 1: Provide the minutes of each meeting of Jessamine District's Board of Commissioners since February 2014 in which the proposed rate revision was discussed.

Answer: See attached minutes.

[Witness: L. Nicholas Strong]

October 1, 2014

The Board of Commissioners of the Jessamine South Elkhorn Sewer Division met on October 1, 2014, with the following Commissioners present: Nick Strong, George Dale Robinson, Tom Beall, Jerry Haws, and JF Hall. Bruce Smith, John Horne, Christopher Horne, Richard Decker, Tom Smith, Glenna Richardson and Diana Clark were also present.

There was a review of the Aged Receivables.

Mr. Smith reported on the **Brannon Crossing** Warranty Bonds. During the mediation an offer was made by Western Surety that was a substantially below the Districts damages. The mediation was not successful. Other negotiations are still pending.

Mr. Smith reported on the proposed filing of the **Non-Recurring Charges Tariff**. It was suggested to re-evaluate the tap fees based on whether the District actually installs the lateral and submit and alternative tap fee charge. Mr. Smith presented a revised tariff sheet for non-recurring charges. There was a lengthy discussion on the charges. Mr. Smith was authorized to submit the revised tariff sheet presented to the PSC.

Mr. Horne reported on his meetings with LFUCG concerning the CAP status.

Mr. Horne reported that **Ash Tree (Ball Homes)** was planning a zone change but had not made a request to the District concerning this change which could change the capacity previously requested. Mr. Smith did disclose to the Board that he represented Ball Homes concerning the zone change.

There was a discussion on future capacity. Mr. Horne suggested to the Board that a timeframe for completion be set on future developments with requested capacity.

A motion to approve the minutes of the September meeting was made by Mr. Robinson, seconded by Mr. Hall – approved.

The motion to approve the September bills and pre-approval of contractual payables was made as a Water item.

The Commissioners were given the following reports for review: Income Statement and Balance Sheet.

There being no further business to come before the Board, meeting adjourned.

Chairman /s/ L. Nicholas Strong ATTEST: /s/ George Dale Robinson

November 5, 2014

The Board of Commissioners of the Jessamine South Elkhorn **Sewer** Division met on November 5, 2014, with the following Commissioners present: Nick Strong, Tom Beall, Jerry Haws, and JF Hall. Bruce Smith, John Horne, Christopher Horne, Richard Decker, Tom Smith, Edward Whitaker and Diana Clark were also present.

There was a review of the Aged Receivables.

Mr. Bruce Smith reported that Town and Country Bank had contacted him regarding the lien on the **White Reach Subdivision**. There was a discussion of the amounts due for the warranty remediation work. Mr. Horne will contact Mr. Smith with updated amounts.

Mr. Bruce Smith reported on the **City of Nicholasville** Warranty Bonds. Bond Safeguard accepted an offer pending agreement of escrow and lien releases. Negotiations continue. Western Surety summary judgment meeting will be in December. XL Specialty mediation meeting will be in November.

Mr. Bruce Smith reported on the progress of the proposed **Non-Recurring Charges Tariff**. The 30-day time limit for review by the PSC has been suspended until April 2015.

The **2015 Budget** was presented to the Board for review. A motion to approve the 2015 budget was made by Mr. Beall, seconded by Mr. Haws – approved.

There was a discussion about the Christmas party which included the date, time, place, and list of invitees.

There was a discussion regarding fencing of the Hullett eastern property line fence from the Pump Station to Connie Way Trailer Park. Due to the high cost of a boundary survey, the Commissioners directed that the fence be constructed inside the existing fence row trees and that the District's contractor assist in clearing.

There was a discussion regarding the revised Sewer Request flow chart. A motion to approve the revised sewer request flow chart was made by Mr. Hall, seconded by Mr. Haws – approved.

Mr. Horne reported on the upcoming the Brannon Forcemain Tie In by LFUCG.

Mr. Joe Coons addressed the Board with a request for execution of a Sewer Availability Certificate on an amended plat of Lot 78, Ash Tree Properties.

A motion to approve the minutes of the October meeting was made by Mr. Beall, seconded by Mr. Hall – approved.

The Commissioners were given the following reports for review: Income Statement and Balance Sheet.

There being no further business to come before the Board, meeting adjourned.

Chairman /s/ L. Nicholas Strong

ATTEST: /s/ George Dale Robinson

Jessamine-South Elkhorn Water District

Information Request No. 2: Provide the resolution of Jessamine District's Board of Commissioners in which the proposed rate was approved or, if no resolution was separately prepared, reference the minutes, provided in response to Item one, of the meeting of Jessamine District's Board of Commissioners in which the proposed rates were approved.

Answer: No separate resolution. See October 15, 2014 minutes attached to response to Information Request No. 1.

[Witness: L. Nicholas Strong]

Jessamine-South Elkhorn Water District

Information Request No. 3: List for the calendar year 2014 the total number of Jessamine District's new sewer connections.

Answer: See attached listing.

[Witness: Ed Whitaker]

**JESWD SANITARY SEWER PERMITS
2014**

	<u>PERMIT</u>	<u>DATE</u>	<u>ADDRESS</u>	<u>CLASSIFICATION</u>	<u>RESIDENTIAL FEE PAID</u>	<u>COMMERCIAL FEE PAID</u>
1	710	1/27/2014	108 YATES	SINGLE FAMILY	4,939.92	
2	711	3/18/2014	145 PATMORE	SINGLE FAMILY	1,329.25	
3	713	3/7/2014	206 MORGAN	SINGLE FAMILY	6,269.16	
4	715	3/14/2014	102 LINDLEIGH	SINGLE FAMILY	6,269.16	
5	716	3/18/2014	149 PATMORE	SINGLE FAMILY	1,329.25	
6	717	4/9/2014	107 LINDLEIGH	SINGLE FAMILY	4,939.92	
7	718	4/17/2014	231 YOUNG	MOBILE HOME	1,329.25	
8	719	4/18/2014	105 LINDLEIGH	SINGLE FAMILY	4,939.92	
9	720	4/22/2014	108,110,112,114 DAFFODIL	2 BEDROOM UNIT	5,164.84	
10	721	6/18/2014	111 MILL ROCK	SINGLE FAMILY	3,610.66	
11	722	7/11/2014	104 MANITOO	SINGLE FAMILY	1,329.25	
12	723	7/24/2014	200,202,204,206 DAY LILY	2 BEDROOM UNIT	5,164.84	
13	724	7/24/2014	208,210,212,214 DAY LILY	2 BEDROOM UNIT	5,164.84	
14	725	7/28/2014	139 PATMORE	SINGLE FAMILY	1,329.25	
15	728	8/25/2014	101 CIMMARON	SINGLE FAMILY	2,516.58 *	
16	729	8/27/2014	216,218,220,222 DAY LILY	2 BEDROOM UNIT	5,164.84	
17	731	9/24/2014	101 MANITOO	SINGLE FAMILY	2,516.58 *	
18	732	9/24/2014	116 MANITOO	SINGLE FAMILY	2,516.58 *	
19	733	10/1/2014	108 MANITOO	SINGLE FAMILY	1,355.22 *	
20	734	10/7/2014	217 MALLORY MEADOW	SINGLE FAMILY	1,355.22 *	
21	735	10/27/2014	116 MILL ROCK	SINGLE FAMILY	5,036.38 *	
22	736	11/14/2014	105 MILL ROCK	SINGLE FAMILY	3,681.18 *	
23	737	11/14/2014	109 LAURENBROOK	SINGLE FAMILY	3,681.18 *	
24	738	12/2/2014	107 MILL ROCK	SINGLE FAMILY	3,681.18 *	
25	739	12/8/2014	151 BRANNON MEADOW	TENNIS CENTER		*
26	740	12/15/2014	120 MILL ROCK	SINGLE FAMILY	3,681.18 *	52,788.96
27	742	12/19/2014	100 MANITOO	SINGLE FAMILY	2,516.58 *	
28	743	12/31/2014	109 MILL ROCK	SINGLE FAMILY	3,681.18 *	
					94,493.39	52,788.96

Jessamine-South Elkhorn Water District

Information Request No. 4: For each sewer connection performed for the calendar year 2014, identify the type of building and the amount the customer was charged for the connection.

Answer: See attachment in response to Information Request No. 3.

[Witness: Ed Whitaker]

Jessamine-South Elkhorn Water District

Information Request No. 5: Refer to the application, Nonrecurring Charge Cost Justification form, Section 2. Clerical and Office Expense, B. Labor. The hourly rate listed is \$38.15. Jessamine District's response in Case No. 2013-00470 to Commission Staff's Second "Request for Information ("Staff's Second Request"), Item 1.b.¹, indicates that the gross salary with which the \$38.15 (annual salary of \$60,134 increased to \$62,539) per hour rate was calculated has been revised.

a. Please provide revised detailed hourly labor rate calculations as included in the original response.

Answer: \$24.04 (\$50,000.00 gross salary ÷ 2080 hours)
1.49 (annual SS withholding ÷ 2080 hours)
.35 (annual Medicare withholding ÷ 2080 hours)
2.47 (annual health insurance coverage ÷ 2080 hours)
.09 (annual life insurance coverage cost ÷ 2080 hours)
.06 (annual unemployment insurance withholding ÷ 2080 hours)
.09 (annual workers compensation insurance cost ÷ 2080 hours)
\$28.59 Total

b. Does Jessamine District intend to amend the proposed changes in the application for the revised labor rate?

Answer: Yes. New employee hired at lower salary who perform this task.

[Witness: Ed Whitaker and L. Nicholas Strong]

¹ Case No. 2013-00470, Proposed revisions to Jessamine-South Elkhorn Water District's Rules Regarding the Provision of Sewer Service, filed Apr., 29, 2014

Jessamine-South Elkhorn Water District

Information Request No. 6: Refer to Jessamine District's Response in Case No. 2013-00470 to Staff's Second Request Item 6.a.².

a. Identify, by each water-service provider, the number of requests by Jessamine District to turn off water service for 2014.

Answer: **City of Nicholasville – 2014 (451 requests)**
 Jessamine County Water District No. 1 – 2014 (42 requests)
 Jessamine South Elkhorn Water District – 2014 (798 requests)

b. Provide the names of the utilities that provide water service to Jessamine District's sewer customers and the percentage of customers served by each water utility.

Answer: **City of Nicholasville – 409 customers ÷ 3372 = 12%**
 Jessamine County Water District No. 1 – 232 customers ÷ 3372 = 7%

c. Do the utilities listed in response to 6.b. charge a fee for termination of water service? If so, how much?

Answer: **City of Nicholasville charges \$25.00 per termination.**

[Witness: Ed Whitaker]

² Case No. 2013-00470, Proposed revisions to Jessamine-South Elkhorn Water District's Rules Regarding the Provision of Sewer Service, filed Apr., 29, 2014

Jessamine-South Elkhorn Water District

Information Request No. 7: Provide a diagram of a typical sewer tap depicting the sewer main and the lateral tap. The diagram should clearly show the trench, trench cross-section with dimensions, the lateral pipe including its estimated length, and a list of all materials.

Answer: See attached drawings.

[Witness: John G. Horne]

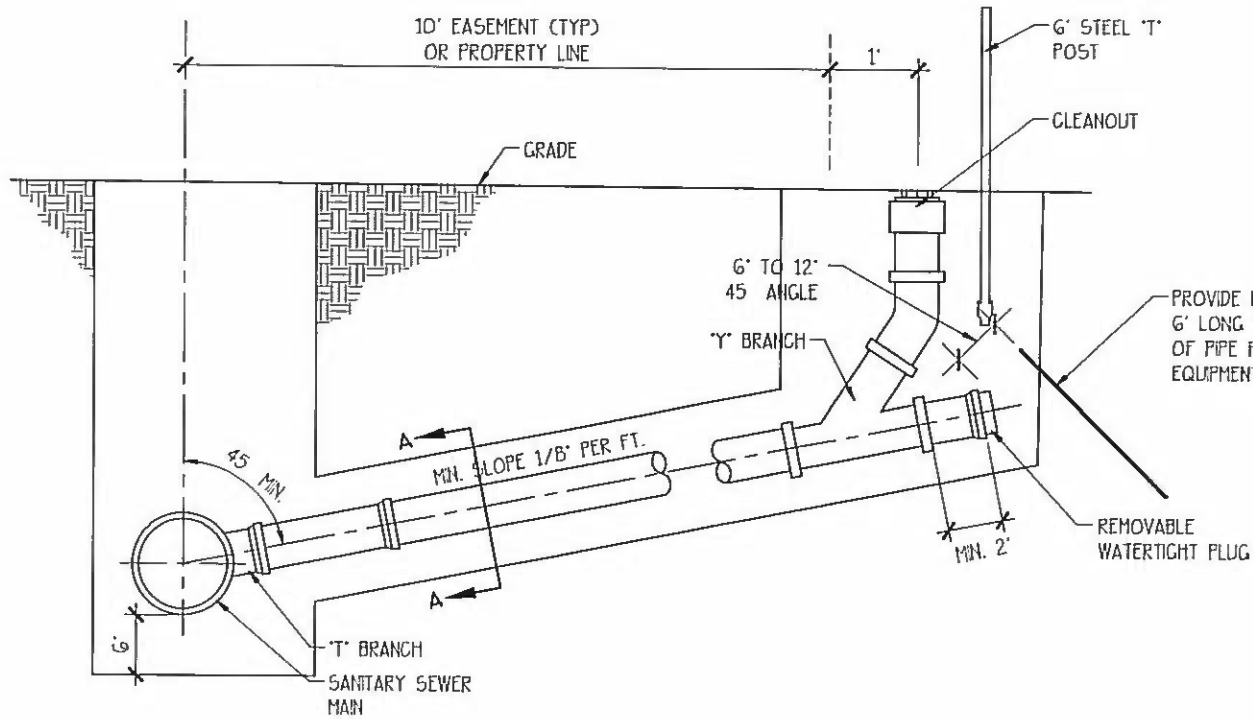

MATERIALS LIST

- T' BRANCH
- 6" PIPE
- Y' BRANCH
- CLEANOUT WITH THREADED PLUG
- REMOVABLE WATERTIGHT PLUG
- 6" STEEL "T" POST
- 6" - NO. 5 REBAR

NOTE

MATERIALS LISTED ARE FOR NEW CONSTRUCTION WHERE THE LATERAL IS INSTALLED AT THE SAME TIME AS THE SEWER MAIN. FOR LATERAL INSTALLATION ON AN EXISTING SEWER MAIN, MATERIAL SHALL INCLUDE REPAIR SLEEVES WHERE "T" BRANCH IS CUT INTO THE SEWER MAIN.

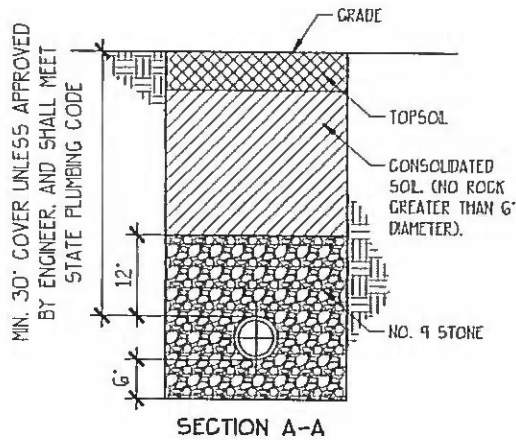

GENERAL NOTES

1. MINIMUM LATERAL SIZE SHALL BE 6". LATERAL MATERIAL SHALL BE SAME AS SEWER MAIN. LATERAL TO BE LAID AT MINIMUM 1/8" PER FOOT SLOPE.
2. CLEANOUT TO BE INSTALLED ON ALL LATERALS. CLEANOUT LOCATION SHALL BE ONE FOOT (1') BEYOND THE EASEMENT LINE OR PROPERTY LINE.
3. LATERALS SHALL HAVE AN EASILY REMOVABLE WATERTIGHT PLUG AT END. INSTALL 6" STEEL "T" POST MARKER AT END OF LATERAL.
4. TRENCH WIDTH FOR LATERAL INSTALLATION SHALL BE A MINIMUM OF 18" WIDE BUT MAY VARY DEPENDING ON DEPTH.
5. LATERAL LENGTH REQUIREMENT IS THE GREATER OF:
 6'-0" AS PROJECTED ON THE HORIZ. PLAIN
 1'-0" OUTSIDE THE EASEMENT
 1'-0" INSIDE THE PROPERTY LINE

NO.	DATE	REVISION	BY

STANDARD DRAWING NO. LD-1

HOUSE LATERAL FOR SHALLOW SEWER IN SOIL OR ROCK

JESSAMINE - SOUTH ELKHORN WATER DISTRICT

J S E W D

GENERAL NOTES

1. MINIMUM LATERAL SIZE SHALL BE 6". LATERAL MATERIAL SHALL BE SAME AS SEWER MAIN. LATERAL TO BE LAID AT MINIMUM 1/8" PER FOOT SLOPE.
2. CLEANOUT TO BE INSTALLED ON ALL LATERALS. CLEANOUT LOCATION SHALL BE ONE FOOT (1') BEYOND THE EASEMENT LINE OR PROPERTY LINE.
3. LATERALS SHALL HAVE AN EASILY REMOVABLE WATERTIGHT PLUG AT END. INSTALL 6" STEEL 'T' POST MARKER AT END OF LATERAL.
4. TRENCH WIDTH FOR LATERAL INSTALLATION SHALL BE A MINIMUM OF 18" WIDE BUT MAY VARY DEPENDING ON DEPTH.
5. IN GENERAL ALL LATERALS SHALL BE INSTALLED TO WITHIN 6" OF THE FINISHED SURFACE GRADE.
6. LATERAL LENGTH REQUIREMENT IS THE GREATER OF: 6'-0" AS PROJECTED ON THE HORIZ. PLAIN 1'-0" OUTSIDE THE EASEMENT 1'-0" INSIDE THE PROPERTY LINE

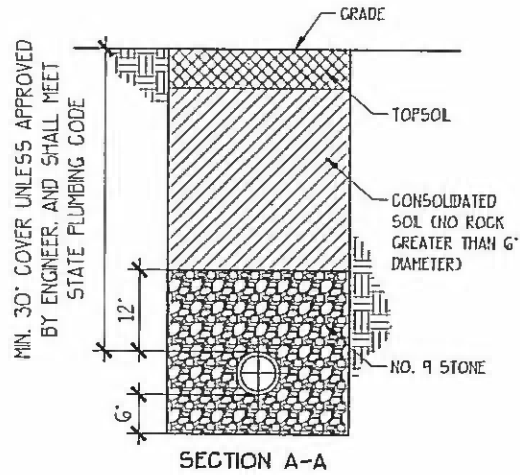
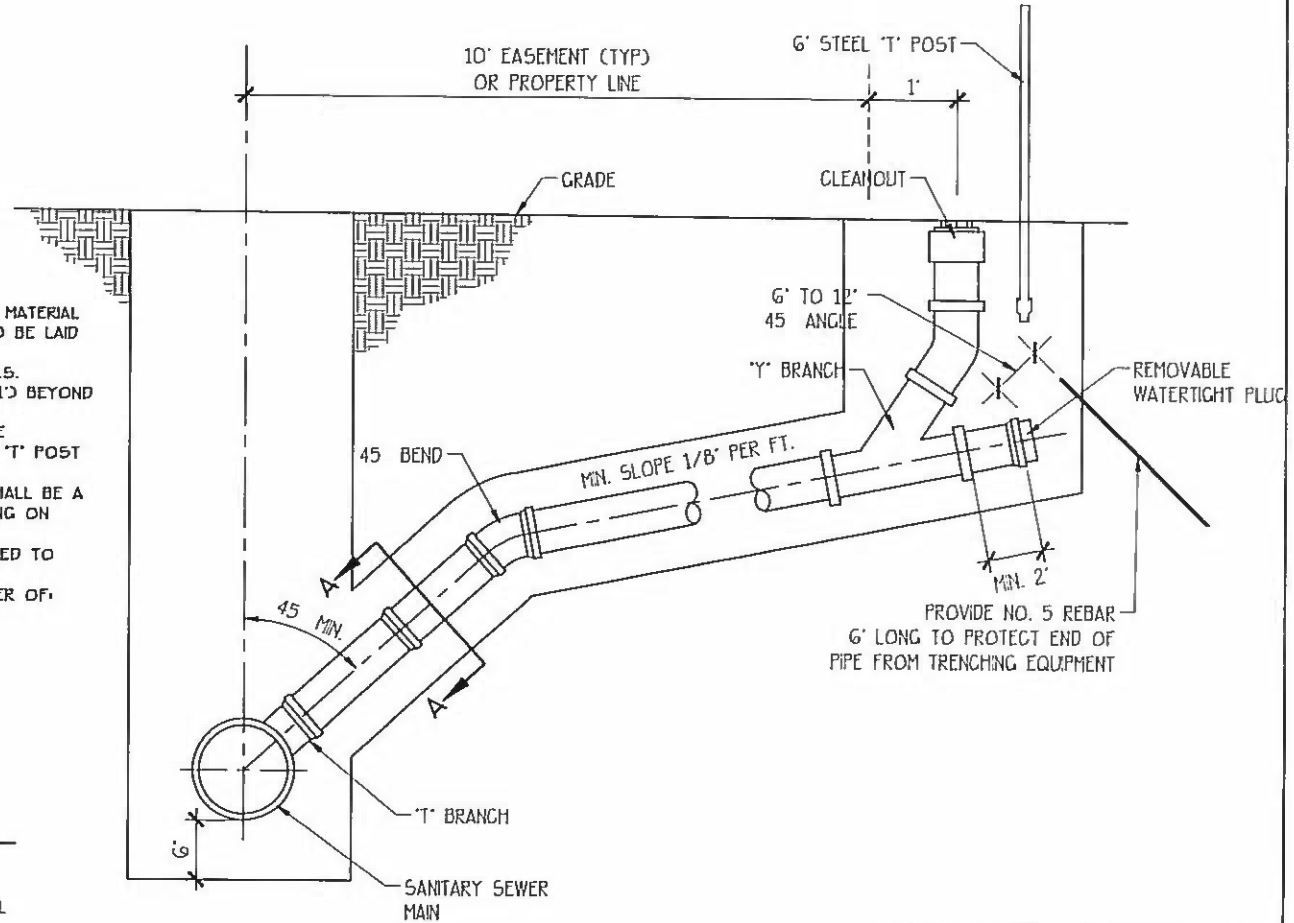

MATERIALS LIST

- T' BRANCH
- 6" PIPE
- Y' BRANCH
- CLEANOUT WITH THREADED PLUG
- 6" STEEL 'T' POST
- 6" - NO. 5 REBAR

NOTE

MATERIALS LISTED ARE FOR NEW CONSTRUCTION WHERE THE LATERAL IS INSTALLED AT THE SAME TIME AS THE SEWER MAIN. FOR LATERAL INSTALLATION ON AN EXISTING SEWER MAIN, MATERIAL SHALL INCLUDE REPAIR SLEEVES WHERE T' BRANCH IS CUT INTO THE SEWER MAIN.

NO.	DATE	REVISION	BY

STANDARD DRAWING NO. LD-2

HOUSE LATERAL FOR GREATER THAN 6' DEEP SEWER IN SOIL

JESSAMINE - SOUTH ELKHORN WATER DISTRICT

J S E W D

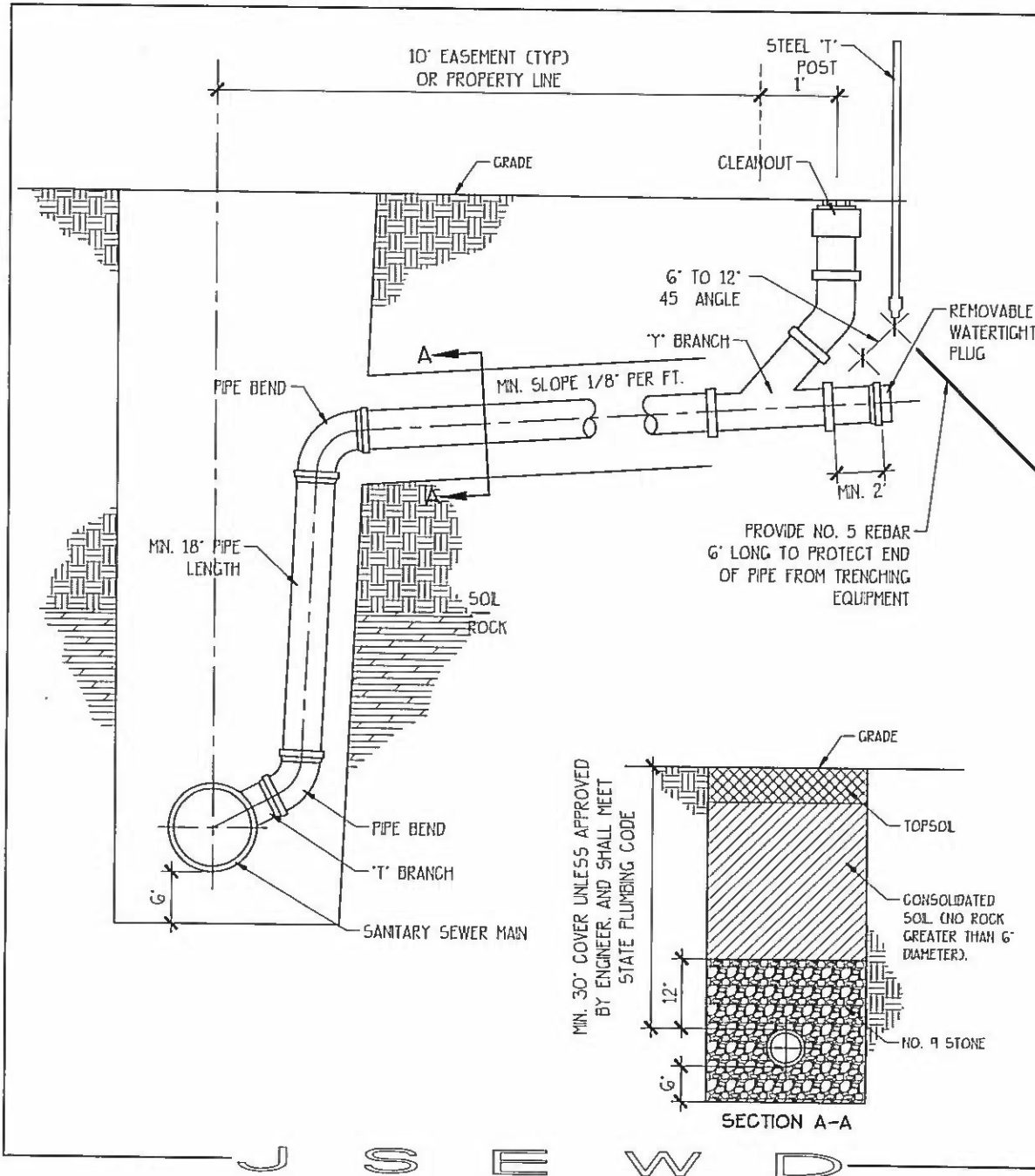

GENERAL NOTES

1. MINIMUM LATERAL SIZE SHALL BE 6". LATERAL MATERIAL SHALL BE SAME AS SEWER MAIN. LATERAL TO BE LAID AT MINIMUM 1/8" PER FOOT SLOPE.
2. CLEANOUT TO BE INSTALLED ON ALL LATERALS. CLEANOUT LOCATION SHALL BE ONE FOOT (1') BEYOND THE EASEMENT LINE OR PROPERTY LINE.
3. LATERALS SHALL HAVE AN EASILY REMOVABLE WATERTIGHT PLUG AT END. INSTALL 6" STEEL 'T' POST MARKER AT END OF LATERAL.
4. TRENCH WIDTH FOR LATERAL INSTALLATION SHALL BE A MINIMUM OF 18" WIDE BUT MAY VARY DEPENDING ON DEPTH.
5. IN GENERAL ALL LATERALS SHALL BE INSTALLED TO WITHIN 6" OF THE FINISHED SURFACE GRADE. LATERAL LENGTH REQUIREMENT IS THE GREATER OF: 6'-0" AS PROJECTED ON THE HORIZ. PLAN 1'-0" OUTSIDE THE EASEMENT 1'-0" INSIDE THE PROPERTY LINE
- 6.

MATERIALS LIST

- 'T' BRANCH
- 6" PIPE
- 'T' BRANCH
- CLEANOUT WITH THREADED PLUG
- REMOVABLE WATERTIGHT PLUG
- 6" STEEL 'T' POST
- 6" - NO. 5 REBAR

NOTE

MATERIALS LISTED ARE FOR NEW CONSTRUCTION WHERE THE LATERAL IS INSTALLED AT THE SAME TIME AS THE SEWER MAIN. FOR LATERAL INSTALLATION ON AN EXISTING SEWER MAIN, MATERIAL SHALL INCLUDE REPAIR SLEEVES WHERE 'T' BRANCH IS CUT INTO THE SEWER MAIN.

NO.	DATE	REVISION	BY

STANDARD DRAWING NO. 1D-3

**HOUSE LATERAL
FOR GREATER THAN 6'
DEEP SEWER
IN SOIL AND ROCK**

JESSAMINE - SOUTH
ELKHORN WATER DISTRICT

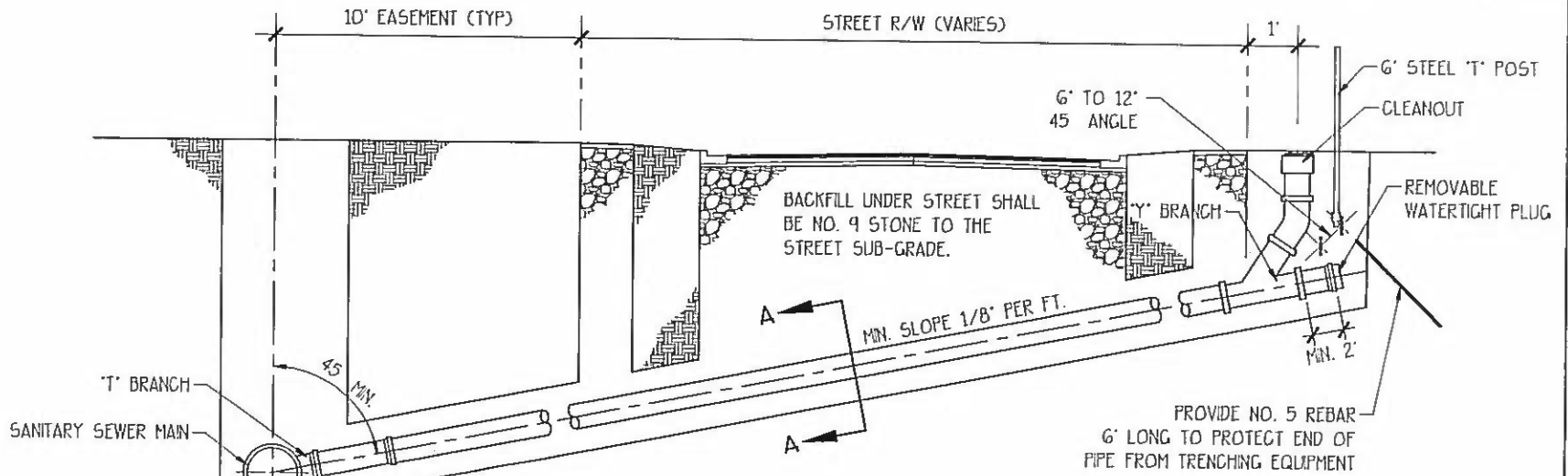

MATERIALS LIST

- T' BRANCH
- 6" PIPE
- Y' BRANCH
- CLEANOUT WITH THREADED PLUG
- REMOVABLE WATERTIGHT PLUG
- 6" STEEL "T" POST
- 6" - NO. 5 REBAR

NOTE

MATERIALS LISTED ARE FOR NEW CONSTRUCTION WHERE THE LATERAL IS INSTALLED AT THE SAME TIME AS THE SEWER MAIN. FOR LATERAL INSTALLATION ON AN EXISTING SEWER MAIN, MATERIAL SHALL INCLUDE REPAIR SLEEVES WHERE T' BRANCH IS CUT INTO THE SEWER MAIN.

GENERAL NOTES

1. MINIMUM LATERAL SIZE SHALL BE 6". LATERAL MATERIAL SHALL BE SAME AS SEWER MAIN. LATERAL TO BE LAID AT MINIMUM 1/8" PER FOOT SLOPE.
2. CLEANOUT TO BE INSTALLED ON ALL LATERALS. CLEANOUT LOCATION SHALL BE ONE FOOT (1') BEYOND THE EASEMENT LINE OR PROPERTY LINE.
3. LATERALS SHALL HAVE AN EASILY REMOVABLE WATERTIGHT PLUG AT END. INSTALL 6" STEEL "T" POST MARKER AT END OF LATERAL.
4. TRENCH WIDTH FOR LATERAL INSTALLATION SHALL BE A MINIMUM OF 18" WIDE BUT MAY VARY DEPENDING ON DEPTH.
5. LATERAL LENGTH REQUIREMENT IS THE WIDTH OF EASEMENT + R/W WIDTH + 1'

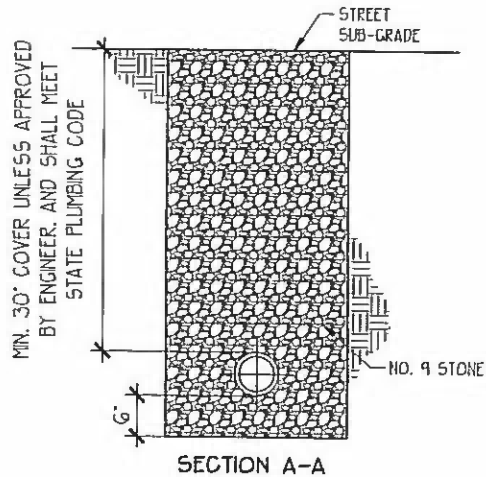

(1) DIMENSIONS SHOWN ARE MINIMUM. IF SURFACE EDGES ARE BROKEN, WIDTH SHALL BE INCREASED AND EACH SIDE MAINTAINED PARALLEL.

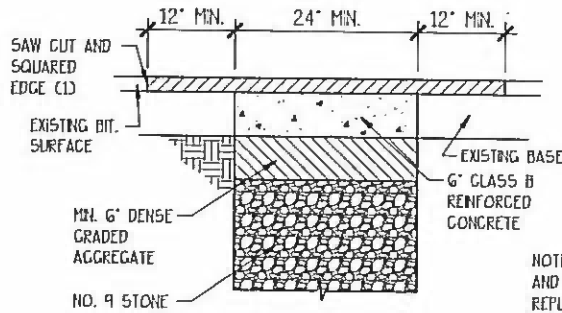

NOTE: CURB AND GUTTER AND SIDEWALKS TO BE REPLACED IN KIND.

EXISTING PAVEMENT REPLACEMENT

NO.	DATE	REVISION	BY

STANDARD DRAWING NO. LD-4

HOUSE LATERAL FOR SHALLOW SEWER IN SOIL OR ROCK (CROSSING R/W)

JESSAMINE - SOUTH ELKHORN WATER DISTRICT

J S E W D

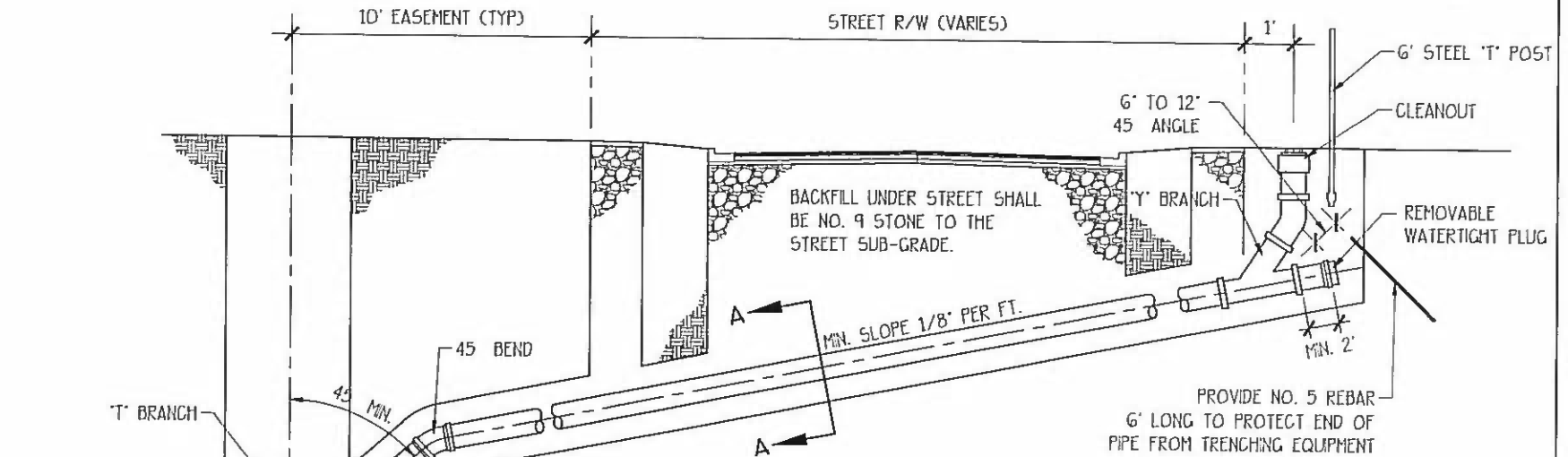

MATERIALS LIST

- T' BRANCH
- 6" PIPE
- Y' BRANCH
- CLEANOUT WITH THREADED PLUG
- REMOVABLE WATERTIGHT PLUG
- 6" STEEL 'T' POST
- 6" - NO. 5 REBAR

NOTE

MATERIALS LISTED ARE FOR NEW CONSTRUCTION WHERE THE LATERAL IS INSTALLED AT THE SAME TIME AS THE SEWER MAIN. FOR LATERAL INSTALLATION ON AN EXISTING SEWER MAIN, MATERIAL SHALL INCLUDE REPAIR SLEEVES WHERE T' BRANCH IS CUT INTO THE SEWER MAIN.

GENERAL NOTES

1. MINIMUM LATERAL SIZE SHALL BE 6". LATERAL MATERIAL SHALL BE SAME AS SEWER MAIN. LATERAL TO BE LAID AT MINIMUM 1/8" PER FOOT SLOPE.
2. CLEANOUT TO BE INSTALLED ON ALL LATERALS. CLEANOUT LOCATION SHALL BE ONE FOOT (1') BEYOND THE EASEMENT LINE OR PROPERTY LINE.
3. LATERALS SHALL HAVE AN EASILY REMOVABLE WATERTIGHT PLUG AT END. INSTALL 6" STEEL 'T' POST MARKER AT END OF LATERAL.
4. TRENCH WIDTH FOR LATERAL INSTALLATION SHALL BE A MINIMUM OF 18" WIDE BUT MAY VARY DEPENDING ON DEPTH.
5. IN GENERAL ALL LATERALS SHALL BE INSTALLED TO WITHIN 6" OF THE FINISHED SURFACE GRADE.
6. LATERAL LENGTH REQUIREMENT IS THE WIDTH OF EASEMENT + R/W WIDTH + 1'

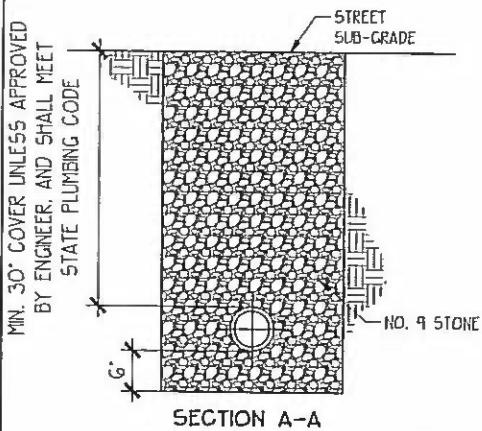

(1) DIMENSIONS SHOWN ARE MINIMUM IF SURFACE EDGES ARE BROKEN. WIDTH SHALL BE INCREASED AND EACH SIDE MAINTAINED PARALLEL.

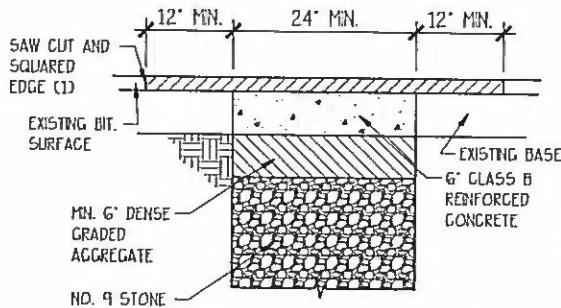

NOTE: CURB AND GUTTER AND SIDEWALKS TO BE REPLACED IN KIND.

EXISTING PAVEMENT REPLACEMENT

NO.	DATE	REVISION	BY

STANDARD DRAWING NO. LD-5

HOUSE LATERAL FOR GREATER THAN 6" DEEP SEWER IN SOIL (CROSSING R/W)

JESSAMINE - SOUTH ELKHORN WATER DISTRICT

J S E W D

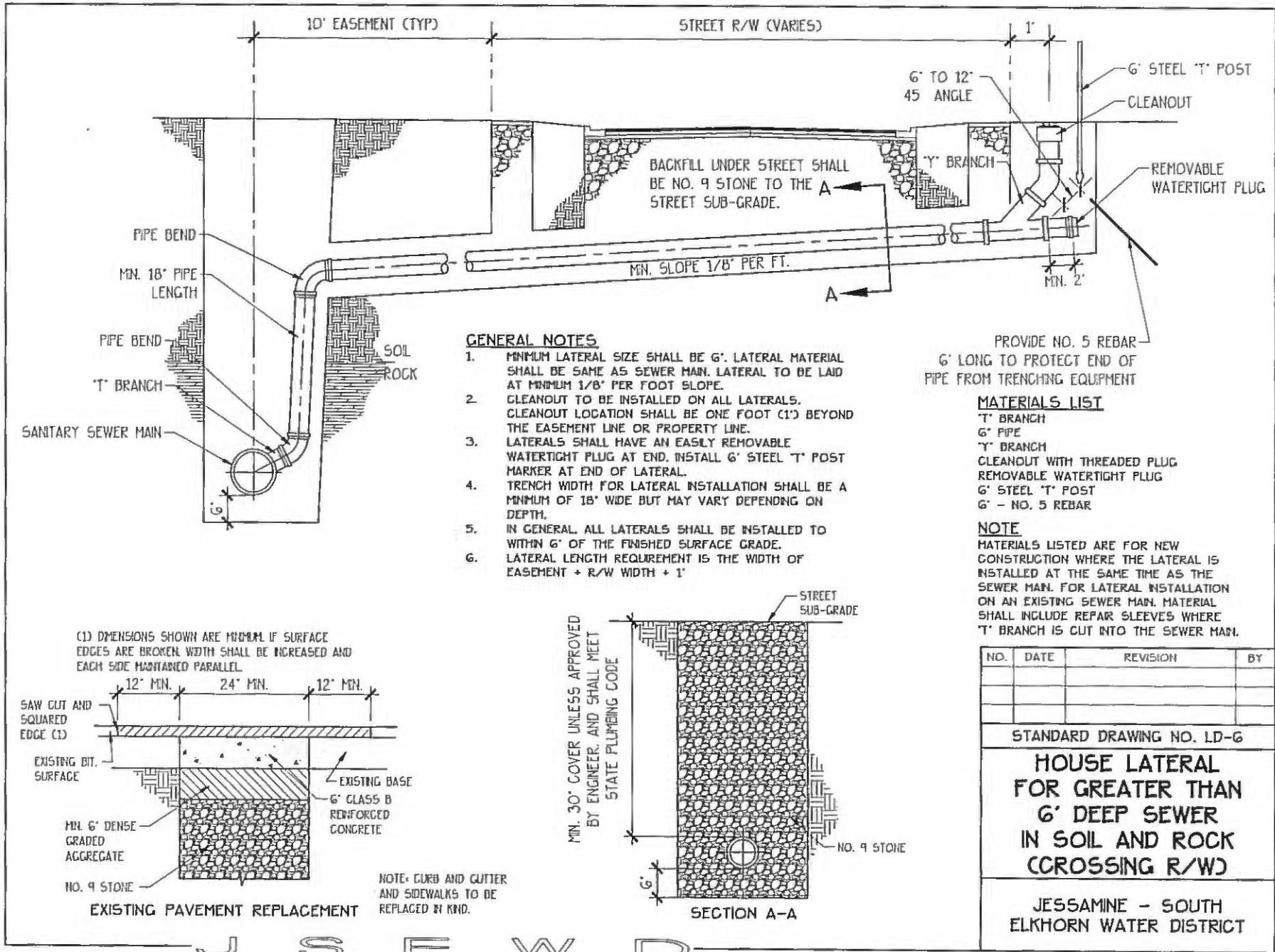

GENERAL NOTES

1. MINIMUM LATERAL SIZE SHALL BE 6". LATERAL MATERIAL SHALL BE SAME AS SEWER MAIN. LATERAL TO BE LAID AT MINIMUM 1/8" PER FOOT SLOPE.
2. CLEANOUT TO BE INSTALLED ON ALL LATERALS. CLEANOUT LOCATION SHALL BE ONE FOOT (1') BEYOND THE EASEMENT LINE OR PROPERTY LINE.
3. LATERALS SHALL HAVE AN EASILY REMOVABLE WATERTIGHT PLUG AT END. INSTALL 6" STEEL T' POST MARKER AT END OF LATERAL.
4. TRENCH WIDTH FOR LATERAL INSTALLATION SHALL BE A MINIMUM OF 18" WIDE BUT MAY VARY DEPENDING ON DEPTH.
5. IN GENERAL ALL LATERALS SHALL BE INSTALLED TO WITHIN 6" OF THE FINISHED SURFACE GRADE.
6. LATERAL LENGTH REQUIREMENT IS THE WIDTH OF EASEMENT + R/W WIDTH + 1'

PROVIDE NO. 5 REBAR 6' LONG TO PROTECT END OF PIPE FROM TRENCHING EQUIPMENT

MATERIALS LIST

- T' BRANCH
- 6" PIPE
- Y' BRANCH
- CLEANOUT WITH THREADED PLUG
- REMOVABLE WATERTIGHT PLUG
- 6" STEEL T' POST
- 6" - NO. 5 REBAR

NOTE

MATERIALS LISTED ARE FOR NEW CONSTRUCTION WHERE THE LATERAL IS INSTALLED AT THE SAME TIME AS THE SEWER MAIN. FOR LATERAL INSTALLATION ON AN EXISTING SEWER MAIN, MATERIAL SHALL INCLUDE REPAIR SLEEVES WHERE T' BRANCH IS CUT INTO THE SEWER MAIN.

NO.	DATE	REVISION	BY

STANDARD DRAWING NO. LD-G

HOUSE LATERAL FOR GREATER THAN 6' DEEP SEWER IN SOIL AND ROCK (CROSSING R/W)

JESSAMINE - SOUTH ELKHORN WATER DISTRICT

J S E W D

Jessamine-South Elkhorn Water District

Information Request No. 8: Refer to Jessamine District's Response in Case No. 2013-00470 to Staff's Second Request Item 10.b. List separately the following information for each of the proposed non-recurring charges from the date that the charge was first made to the present.

- a. The number of occurrences per year the charge was made;
- b. the amount charged for each occurrence;
- c. and the total amount charged per year.

Answer: See attached.

[Witness: Ed Whitaker]

Returned Check Service Charge - 2014 [6 times, \$5 each, \$30 total], 2013 [0 times, \$5 each, \$0 total], 2012 [0 times, \$5 each, \$0 total], 2011 [6 times, \$5 each, \$30 total], 2010 [0 times, \$5 each, \$0 total], 2009 [1 time, \$5 each, \$5 total], 2008 [1 time, \$5 each, \$5 total];

Service Line Inspection Charge – 2010 [12 inspections, \$65 each, \$780 total], 2009 [11 inspections, \$65 each, \$715 total], 2008 [17 inspections, \$65 each, \$1105 total];

Service Termination Charge –2014 [0 times, \$25 each, \$0 total], 2013 [298 times, \$25 each, \$7,450 total], 2012 [399 times, \$25 each, \$9975 total], 2011 [559 times, \$25 each, \$13,975 total], 2010 [18 times, \$25 each, \$450 total], 2009 [2 times, \$25 each, \$50 total], 2008 [0 times, \$25 each, \$0 total], 2007 [0 times, \$25 each, \$0 total], 2006 [3 times, \$25 each, \$75 total];

Grease Trap Inspection Charge – 2012 [5 inspections, \$50 each, \$250], 2011 [20 inspections @ \$50 each and 1 inspection @ \$25 each, \$1,025 total], 2010 [no inspections], 2009 [9 inspections @ \$50 each and 2 inspections @ \$65 each, \$580 total], 2008 [10 inspections @ \$50 each and 1 inspection @ \$65 each, \$565 total];

Unauthorized Use of Service Investigation Charge – None;

Service Charge for Damage to Facilities – None; and

Tap on Fee – See attached sheets that follow. Please note that of the totals charged each year, 2/3 of the amount was paid to the Lexington Fayette Urban County Government pursuant to contract between it and JSEWD.

JSEWD SEWER TAP-ON

DATE	PERMIT #	STREET #	STREET	Type of Building	Amt Charged
<u>2008</u>					
080501	47	301	LINDLEIGH	SINGLE FAMILY RESIDENCE	2,970.00
080501	48	106	YATES	SINGLE FAMILY RESIDENCE	2,340.00
080516	49	601	E BRANNON	COMMERCIAL	6,008.40
080609	49	500	E BRANNON	COMMERCIAL	10,029.60
080616	50	100	E BRANNON	COMMERCIAL	3,366.72
080707	51	111	LAURENBROOK	SINGLE FAMILY RESIDENCE	1,710.00
080722	52	799	E BRANNON	COMMERCIAL	5,810.40
080725	53	108	MILL ROCK	SINGLE FAMILY RESIDENCE	1,170.00
081003	54	200	ABBY DEEANN	SINGLE FAMILY RESIDENCE	1,170.00
081023	55	251	LANGLEY	SINGLE FAMILY RESIDENCE	3,375.36
10					<u>37,950.48</u>

<u>2009</u>					
090123	56	4080	LEXINGTON RD	COMMERCIAL	51,266.88
090323	57	4089	LEXINGTON RD	COMMERCIAL	7,550.00
090323	58	107	MORGAN CT	SINGLE FAMILY RESIDENCE	2,970.00
090420	59	1101	LAUDERDALE DR	COMMERCIAL	8,553.60
090429	60		TOWN & COUNTRY BANK	COMMERCIAL	5,760.00
090513	61	516	BRANNON MEADOW	SINGLE FAMILY RESIDENCE	630.00
090513	62	213	RED OAK	SINGLE FAMILY RESIDENCE	630.00
090722	63	537	BRANNON MEADOW	SINGLE FAMILY RESIDENCE	630.00
090803	64	100	LINDLEIGH	SINGLE FAMILY RESIDENCE	2,970.00
090807	65	201	RED OAK	SINGLE FAMILY RESIDENCE	630.00
090819	66	610	E BRANNON	COMMERCIAL	17,164.80
090904	67	100	ELK GROVE	SINGLE FAMILY RESIDENCE	1,170.00
090921	68	208	RED OAK	SINGLE FAMILY RESIDENCE	630.00
090921	69	204	LINDLEIGH	SINGLE FAMILY RESIDENCE	2,970.00
090921	70	200	LINDLEIGH	SINGLE FAMILY RESIDENCE	2,970.00
090924	71	106	MILL ROCK	SINGLE FAMILY RESIDENCE	1,170.00
090929	72	304	PATMORE	SINGLE FAMILY RESIDENCE	1,170.00
091116	73	300	LINDLEIGH	SINGLE FAMILY RESIDENCE	5,935.50
091116	74	202	LINDLEIGH	SINGLE FAMILY RESIDENCE	5,935.50
091124	75	404	PATMORE	SINGLE FAMILY RESIDENCE	2,337.00
091125	76	205	RED OAK	SINGLE FAMILY RESIDENCE	1,258.50
21					<u>124,301.78</u>

<u>2010</u>					
100121	77	200	MORGAN CT	SINGLE FAMILY RESIDENCE	2,337.00
100223	78	100	EMMA KATHERINE	SINGLE FAMILY RESIDENCE	2,337.00

100223	79	112 EMMA KATHERINE	SINGLE FAMILY RESIDENCE	1,258.50
100225	80	401 PATMORE	SINGLE FAMILY RESIDENCE	2,337.00
100303	81	404 BRANNON MEADOW	SINGLE FAMILY RESIDENCE	2,337.00
100318	82	112 MILL ROCK	SINGLE FAMILY RESIDENCE	3,418.50
100318	83	104 EMMA KATHERINE	SINGLE FAMILY RESIDENCE	1,258.50
100512	84	112 MANITOO	SINGLE FAMILY RESIDENCE	2,337.00
100726	341	108 MALLORY WAY	SINGLE FAMILY RESIDENCE	1,258.50
100927	605	101 ABBY DEEANN	SINGLE FAMILY RESIDENCE	2,348.24
100927	606	104 MALLORY MEADOW	SINGLE FAMILY RESIDENCE	1,264.50
100927	607	100 MALLORY MEADOW	SINGLE FAMILY RESIDENCE	2,348.24
101004	608	110 CYNTHIA DR	SINGLE FAMILY RESIDENCE	9,556.56
				<hr/>
				34,396.54

13

2011

110104	651	204 RED OAK WAY	SINGLE FAMILY RESIDENCE	1,264.50
110104	652	105 ABBY DEEANN	SINGLE FAMILY RESIDENCE	1,264.50
110216	232	105 EMMA KATHERINE	SINGLE FAMILY RESIDENCE	1,264.50
110222	306	220 MALLORY MEADOW	SINGLE FAMILY RESIDENCE	1,264.50
110224	308	305 LINDLEIGH	SINGLE FAMILY RESIDENCE	4,699.50
110302	316	208 MALLORY MEADOW	SINGLE FAMILY RESIDENCE	1,264.50
110407	439	408 PATMORE	SINGLE FAMILY RESIDENCE	2,348.24
110411	454	204 MALLORY MEADOW	SINGLE FAMILY RESIDENCE	1,264.50
110503	514	212 MALLORY MEADOW	SINGLE FAMILY RESIDENCE	1,264.50
110503	483	104 RED OAK WAY	SINGLE FAMILY RESIDENCE	2,348.24
110627	544	201 ABBY DEEANN	SINGLE FAMILY RESIDENCE	1,264.50
110727	546	200 MALLORY MEADOW	SINGLE FAMILY RESIDENCE	1,285.67
110830	547	205 MALLORY MEADOW	SINGLE FAMILY RESIDENCE	1,285.67
110907	549	300 BRANNON MEADOW	SINGLE FAMILY RESIDENCE	2,387.43
110921	551	405 PATMORE	SINGLE FAMILY RESIDENCE	2,387.43
111003	552	106 LINDLEIGH	SINGLE FAMILY RESIDENCE	6,063.59
111010	562	440 E BRANNON	COMMERCIAL	9,220.44
111208	633	302 LINDLEIGH	SINGLE FAMILY RESIDENCE	6,063.59
111213	634	216 MALLORY MEADOW	SINGLE FAMILY RESIDENCE	1,285.67
				<hr/>
				49,491.47

19

2012

120110	638	118 MILL ROCK	SINGLE FAMILY RESIDENCE	3,492.27
120305	639	108 EMMA KATHERINE	SINGLE FAMILY RESIDENCE	1,285.67
120411	640	209 MALLORY MEADOW	SINGLE FAMILY RESIDENCE	1,285.67
120417	654	109 ABBY DEEANN	SINGLE FAMILY RESIDENCE	1,285.67
120509	655	308 BRANNON MEADOW	SINGLE FAMILY RESIDENCE	1,285.67
120516	656	306 LINDLEIGH	SINGLE FAMILY RESIDENCE	4,777.94
120618	660	109 YATES CT	SINGLE FAMILY RESIDENCE	6,063.59
120628	661	5220 GREY OAK	APTS/COMMERCIAL	53,720.66
120712	662	329 PATMORE	SINGLE FAMILY RESIDENCE	2,387.43

120910	665	200 PETUNIA	SINGLE FAMILY RESIDENCE	1,315.28
120910	664	102-108 BRANNON GARDENS	CONDOS	5,110.56
120910	666	110-116 BRANNON GARDENS	CONDOS	5,110.56
120921	667	5204 GREY OAK	SINGLE FAMILY RESIDENCE	1,315.28
120924	668	113 ABBY DEEANN	SINGLE FAMILY RESIDENCE	1,315.28
121109	670	5212 GREY OAK	SINGLE FAMILY RESIDENCE	1,315.28
121126	671	203 LINDLEIGH	SINGLE FAMILY RESIDENCE	6,203.22
121130	672	116-122 DAY LILY	CONDOS	5,110.56
121212	673	109 EMMA KATHERINE	SINGLE FAMILY RESIDENCE	1,315.28
				<hr/>
				103,695.87

18

2013

130130	674	115 LAURENBROOK	SINGLE FAMILY RESIDENCE	4,887.96
130131	675	114 LAURENBROOK	SINGLE FAMILY RESIDENCE	6,203.22
130211	677	128 PATMORE	SINGLE FAMILY RESIDENCE	2,442.41
130215	678	5100 GREY OAK	SINGLE FAMILY RESIDENCE	2,442.41
130320	680	325 PATMORE	SINGLE FAMILY RESIDENCE	1,315.28
130320	679	5108 GREY OAK	SINGLE FAMILY RESIDENCE	2,442.41
130422	682	120 PATMORE	SINGLE FAMILY RESIDENCE	1,315.28
130422	683	124 PATMORE	SINGLE FAMILY RESIDENCE	1,315.28
130506	685	113-119 BRANNON GARDENS	CONDOS	5,110.56
130506	684	108-114 DAY LILY	CONDOS	5,110.56
130507	686	308 PATMORE	SINGLE FAMILY RESIDENCE	2,442.41
130613	689	101-103 BRANNON GARDENS	CONDOS	2,555.28
130613	691	105-111 BRANNON GARDENS	CONDOS	5,110.56
130618	692	100 CIMMARON CT	SINGLE FAMILY RESIDENCE	2,442.41
130621	693	205-211 DAY LILY	CONDOS	5,110.56
130731	694	5104 GREY OAK	SINGLE FAMILY RESIDENCE	1,329.25
130822	695	144 PATMORE	SINGLE FAMILY RESIDENCE	2,468.37
130918	696	109 MANITOO PL	SINGLE FAMILY RESIDENCE	1,329.25
130924	697	100-106 DAFFODIL CT	CONDOS	5,164.84
131023	698	400 PATMORE	SINGLE FAMILY RESIDENCE	1,329.25
131101	700	132 PATMORE	SINGLE FAMILY RESIDENCE	2,468.37
131112	701	100 BRANNON GARDENS	POOL/COMMERCIAL	5,084.21
131112	702	104 YATES CT	SINGLE FAMILY RESIDENCE	6,269.16
131114	703	113 MANITOO PL	SINGLE FAMILY RESIDENCE	2,468.37
131125	704	105 MANITOO PL	SINGLE FAMILY RESIDENCE	1,329.25
131211	705	460 E BRANNON	COMMERCIAL	11,598.38
131218	707	136 PATMORE	SINGLE FAMILY RESIDENCE	2,468.37
131218	706	209 PATMORE	SINGLE FAMILY RESIDENCE	1,329.25
131219	708	213 MALLORY MEADOW	SINGLE FAMILY RESIDENCE	1,329.25
				<hr/>
				96,212.16

29

2014

140127	710	108 YATES	SINGLE FAMILY RESIDENCE	4,939.92
--------	-----	-----------	-------------------------	----------

140318	711	145 PATMORE	SINGLE FAMILY RESIDENCE	1,329.25
140307	713	206 MORGAN	SINGLE FAMILY RESIDENCE	6,269.16
140314	715	102 LINDLEIGH	SINGLE FAMILY RESIDENCE	6,269.16
140318	716	149 PATMORE	SINGLE FAMILY RESIDENCE	1,329.25
140409	717	107 LINDLEIGH	SINGLE FAMILY RESIDENCE	4,939.92
140417	718	231 YOUNG	SINGLE FAMILY RESIDENCE	1,329.25
140418	719	105 LINDLEIGH	SINGLE FAMILY RESIDENCE	4,939.92
140422	720	108-114 DAFFODIL	CONDOS	5,164.84
140618	721	111 MILL ROCK	SINGLE FAMILY RESIDENCE	3,610.66
140711	722	104 MANITOO	SINGLE FAMILY RESIDENCE	1,329.25
140724	723	200-206 DAY LILY	CONDOS	5,164.84
140724	724	208-214 DAY LILY	CONDOS	5,164.84
140728	725	139 PATMORE	SINGLE FAMILY RESIDENCE	1,329.25
140825	728	101 CIMMARON	SINGLE FAMILY RESIDENCE	2,516.58
140827	729	216-222 DAY LILY	CONDOS	5,164.84
140924	731	101 MANITOO	SINGLE FAMILY RESIDENCE	2,516.58
140924	732	116 MANITOO	SINGLE FAMILY RESIDENCE	2,516.58
141001	733	108 MANITOO	SINGLE FAMILY RESIDENCE	1,355.22
141007	734	217 MALLORY MEADOW	SINGLE FAMILY RESIDENCE	1,355.22
141027	735	116 MILL ROCK	SINGLE FAMILY RESIDENCE	5,036.38
141114	736	105 MILL ROCK	SINGLE FAMILY RESIDENCE	3,681.18
141114	737	109 LAURENBROOK	SINGLE FAMILY RESIDENCE	3,681.18
141202	738	107 MILL ROCK	SINGLE FAMILY RESIDENCE	3,681.18
141208	739	151 BRANNON MEADOW	COMMERCIAL	52,788.96
141215	740	120 MILL ROCK	SINGLE FAMILY RESIDENCE	3,681.18
141219	742	100 MANITOO	SINGLE FAMILY RESIDENCE	2,516.58
141231	743	109 MILL ROCK	SINGLE FAMILY RESIDENCE	3,681.18
				<hr/>
				147,282.35

28

2015

150105	744	618 OLD COACH	SINGLE FAMILY RESIDENCE	3,681.18
150126	745	109 CIMMARON	SINGLE FAMILY RESIDENCE	2,516.58
150205	746	1060 LAUDERDALE DR	SINGLE FAMILY RESIDENCE	1,355.22
150205	747	1056 LAUDERDALE DR	SINGLE FAMILY RESIDENCE	1,355.22
150205	748	1052 LAUDERDALE DR	SINGLE FAMILY RESIDENCE	1,355.22
150205	749	1048 LAUDERDALE DR	SINGLE FAMILY RESIDENCE	1,355.22
150210	741	801 E BRANNON	APTS/COMMERCIAL	294,111.03
150213	750	615 OLD COACH	SINGLE FAMILY RESIDENCE	5,036.38
				<hr/>
				310,766.05

8

CERTIFICATION

Comes L. Nicholas Strong, Chairman of the Jessamine-South Elkhorn Water District ("District") and after first being duly sworn states that he supervised the preparation of this response on behalf of the District and that the foregoing responses are true and accurate to his knowledge, information and belief after a reasonable inquiry.

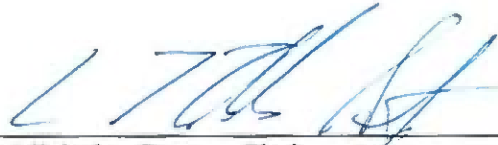

L. Nicholas Strong, Chairman

COMMONWEALTH OF KENTUCKY
COUNTY OF JESSAMINE, SCT...

Acknowledged, subscribed and sworn to me, a Notary Public in and before said County and State by L. Nicholas Strong, Chairman, this the 26 day of February, 2015.

My commission expires: March 23, 2016



NOTARY PUBLIC NO. 462730

Respectfully Submitted,

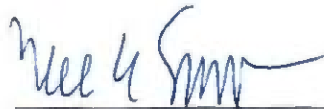

Bruce E. Smith, Esq.
201 South Main Street
Nicholasville, Kentucky 40356
T: (859) 885-3393/F: (859) 885-1152
bruce@smithlawoffice.net
COUNSEL FOR DISTRICT