



Steven L. Beshear
Governor

Leonard K. Peters
Secretary
Energy and Environment Cabinet

Commonwealth of Kentucky
Public Service Commission
211 Sower Blvd.
P.O. Box 615
Frankfort, Kentucky 40602-0615
Telephone: (502) 564-3940
Fax: (502) 564-3460
psc.ky.gov

David L. Armstrong
Chairman

James W. Gardner
Vice Chairman

Charles R. Borders
Commissioner

October 24, 2011

Mr. Jeff Derouen
Executive Director
Public Service Commission
P.O. Box 615
Frankfort, KY 40602

Re: Inter-County Energy Cooperative Corporation
Case No. 2011-00280

Dear Mr. Derouen:

Attached hereto is the Stipulation of Facts and Settlement Agreement entered into by Inter-County Energy Cooperative Corporation and Staff. Please bring this document to the Commission's attention for its review and consideration.

Sincerely,

A handwritten signature in cursive script that reads "L. Allyson Honaker".

L. Allyson Honaker
Staff Attorney III

Enclosure

cc: Hadden Dean

COMMONWEALTH OF KENTUCKY
BEFORE THE PUBLIC SERVICE COMMISSION

RECEIVED

OCT 20 2011

PUBLIC SERVICE
COMMISSION

In the Matter of:

INTER-COUNTY ENERGY COOPERATIVE)
CORPORATION)

_____))
ALLEGED FAILURE TO COMPLY)
WITH KRS 278.042)

CASE NO. 2011-00280

STIPULATION OF FACTS AND SETTLEMENT AGREEMENT

This agreement is formally known as a Stipulation of Facts and Settlement Agreement ("Settlement Agreement"). The parties to this Settlement Agreement are Inter-County Energy Cooperative Corporation ("Inter-County") and Staff of the Kentucky Public Service Commission ("Commission Staff"). It is the intent and purpose of the parties hereto to express their agreement on a mutually satisfactory resolution of all of the issues in the proceeding.

It is understood by the parties that this Settlement Agreement is not binding upon the Public Service Commission ("Commission"). The Commission must independently approve and adopt this Settlement Agreement before this matter can be deemed concluded and removed from the Commission's docket. The parties have expended considerable efforts to reach a stipulation as to the facts of this matter, as well as in developing a proposal for settlement. Inter-County and Commission Staff agree that this Settlement Agreement, viewed in its entirety, constitutes a reasonable resolution of all issues in this proceeding.

In addition, the adoption of this Settlement Agreement will eliminate the need for the Commission, Commission Staff, and Inter-County to expend significant resources in litigating this proceeding and will eliminate the possibility of, and any need for, rehearing or appeals of the Commission's final Order.

FACTS

Inter-County and the Commission Staff submit this stipulation of facts for the Commission's consideration. Commission Staff developed and submitted to the Commission an Incident Investigation-Staff Report ("Report") on this matter signed and dated May 26, 2011. The Report describes an incident which occurred on April 6, 2011, in Lancaster, Kentucky, in which Justin Hubbard, an employee of Bluegrass Ag Distributors ("Bluegrass"), was injured when the portable grain auger he was working with made contact with Inter-County's primary conductor.

According to the Report, on the day of the incident the victim and another Bluegrass employee, Warren Gooch, were preparing to move a forty-eight foot portable grain auger from one grain bin to another near Inter-County's primary conductor. Mr. Hubbard was attempting to reposition the grain auger when it made contact with Inter-County's primary conductor. Mr. Hubbard was examined at the incident site by Lancaster EMS and drove himself to Fort Logan Hospital. He was reported to have burns to his hand and his foot.

Inter-County and Commission Staff agree that the Report fairly and accurately describes events which occurred on the day of the April 6, 2011 incident.

Show Cause Order

By a Show Cause Order dated, August 18, 2011, the Commission initiated this proceeding to determine whether Inter-County should be subject to the penalties prescribed in KRS 278.990 for a probable violation of KRS 278.042, which requires the Commission to ensure that an electric utility constructs and maintains its plant and facilities in accordance with the 2007 edition of the National Electric Safety Code (“NESC”). The alleged violation cited in the Commission’s August 18, 2011, Order is as follows:

1. 2007 NESC Section 23, Rule 234.F.2(a)—Clearance of Wires, Conductors, Cables, and Equipment from Buildings, Bridges, Rail Cars, Swimming Pools, and Other Installations.
 - F. Clearances of Wires, Conductors, Cables, and Rigid Live Parts from Grain Bins
 2. Grain Bins Loaded by Portable Augers, Conveyers, or Elevators (With No Wind Displacement)
 - a. The clearance of wires, conductors, cables, and rigid live parts from grain bins that are expected to be loaded by the use of a portable auger, conveyer, or elevator shall be not less than the values illustrated in Fig 234-4b

Fig 234-4(b): Clearance Envelope for Grain Bins Filled by Portable Augers, Conveyors, or Elevators

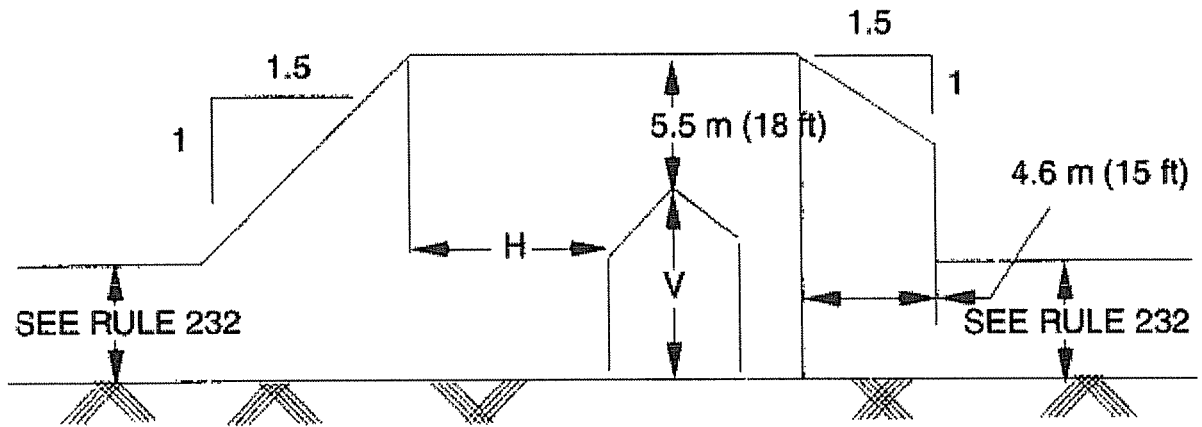

$V =$ HEIGHT OF HIGHEST FILLING OR PROBING PORT ON GRAIN BIN
 $H = V + 5.5 \text{ m (18 ft)}$

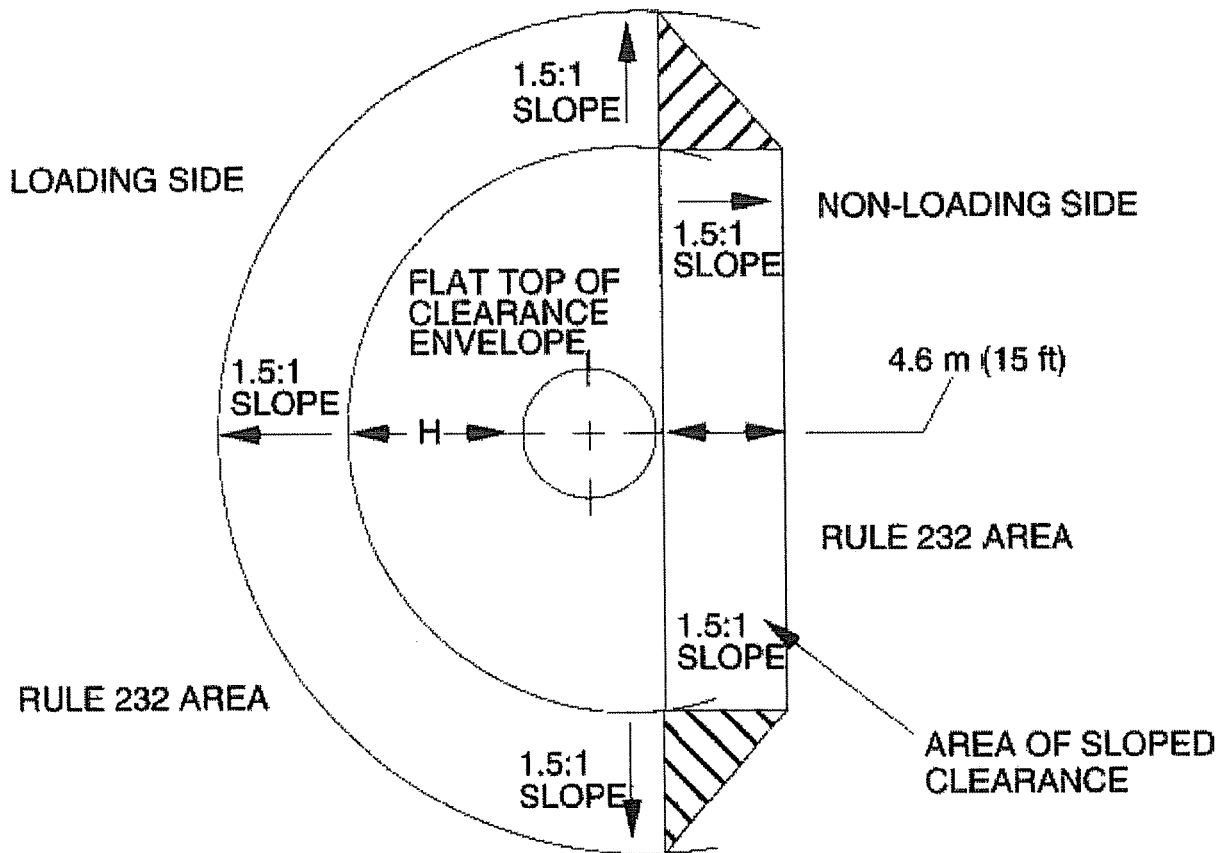

On September 2, 2011, Inter-County filed a response to the Commission's August 18, 2011, Order. In its response, Inter-County requested an informal conference be held in this matter. Pursuant to that request, an informal conference was scheduled in this matter for September 27, 2011, at the Commission's Frankfort offices. Representatives of Inter-County were in attendance, as were Commission Staff.

During the informal conference representatives of Inter-County confirmed that they have taken proactive steps to enhance the safety program, and that a system wide inspection looking for this type of clearance violation had already taken place.

SETTLEMENT AGREEMENT

As a result of discussions held during the informal conference, Inter-County and the Commission Staff submit the following settlement agreement for the Commission's consideration in this proceeding:

1. Inter-County agrees that the Commission Staff's Incident Investigation – Staff Report, Appendix A to the Commission's August 18, 2011, Order in this matter, accurately describes and sets forth material facts and circumstances surrounding the April 6, 2011, incident.

2. In settlement of this proceeding, Inter-County agrees for a civil penalty of \$2,500 to be assessed. Inter-County agrees to pay \$1,500 of the civil penalty within 30 days of the date of the Order approving this settlement. The scope of this proceeding is limited by the Commission's August 18, 2011 Order on whether Inter-County should be assessed a penalty under KRS 278.990 for willful violations of the NESC rules as made applicable under KRS 278.042 and the adequacy, safety, and reasonableness of its practices related to the construction, installation and repair of electric facilities and

whether such practices require revision. Neither the payment of the \$1,500 nor any other agreement contained in this Stipulation, shall be construed as an admission by Inter-County of any liability in this matter, or in any legal proceeding or lawsuit arising out of the facts set forth in the Report, nor shall the Commission's acceptance of this Settlement Agreement be construed as a finding of a willful violation of any Commission regulation or NESC rule.

3. Inter-County agrees that the remaining amount of the civil penalty, \$1,000 is suspended and should be imposed upon Inter-County if it fails to comply with any provision of this Stipulation, and that such suspended penalty shall become due and payable if Inter-County does not remedy its failure to comply within 30 days after the Commission has issued written notice to Inter-County.

4. Within 30 days of the date of entry of the Order approving this Settlement Agreement, Inter-County shall provide to the Commission documentation on the training given as a result of this incident, including the type of training, who attended, and how this training will be implemented into the training program on a regular basis. Inter-County will continue to provide training specifically on the NESC and clearance issues at least on a quarterly basis.

5. Within 30 days of the date of the entry of this Order approving this Settlement Agreement, Inter-County shall provide to the Commission a summary report of the system inspection performed as a result of this incident. The report shall contain all potential violations found - including this type of clearance violation - and the curative action taken including the timeframe they were corrected. The specific service orders or

further specific information regarding this inspection process shall be made available to Commission inspectors upon request during periodic inspections.

6. No later than March 30, 2012, Inter-County shall provide to the Commission a report of its normal 2 year system-wide inspection, which is to be completed by December 31, 2011. The report shall contain information on the type of violations found, the manner in which they were corrected and the timeframe within which they were corrected. Specific information regarding this inspection shall be made available to Commission inspectors upon request during periodic inspections.

7. Inter-County shall provide information in each issue of its monthly magazine issued to all customers, regarding safety, beginning with the December 2011, issue. At least once per year Inter-County will provide specific information on clearance issues in the magazine.

8. In the event that the Commission does not accept this Settlement Agreement in its entirety, Inter-County and Commission Staff reserve their rights to withdraw from it and require that a hearing be held on any and all issues involved and that none of the provisions contained within this Settlement Agreement shall be binding upon the parties, used as an admission by Inter-County of any liability in any legal proceeding, administrative proceeding or lawsuit arising out of the facts set forth in the Accident Report and the Inspection Report or otherwise used as an admission by either party.

9. This Settlement Agreement is for use in Commission Case No. 2011-00280, and no party to this matter shall be bound by any part of this Settlement Agreement in any other proceeding, except that this Settlement Agreement may be used in any proceedings by the Commission to enforce the terms of this Settlement

Agreement or to conduct a further investigation of Inter-County's service. Inter-County shall not be precluded or estopped from raising any issue, claim or defense therein by reason of the execution of this Settlement Agreement.

10. Inter-County and Commission Staff agree that this Settlement Agreement is reasonable, is in the public interest, and should be adopted in its entirety by the Commission. If adopted by the Commission, Inter-County agrees to waive its right to a hearing and will not file any petition for rehearing or seek judicial appeal.

INTER-COUNTY ENERGY COOPERATIVE CORPORATION

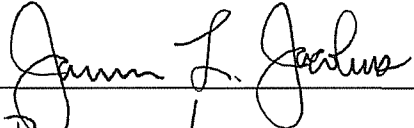
By: (print name) JAMES L. JACOBUS
By: (sign name) 
Title: PRESIDENT / CEO
Date: 10/19/11

STAFF OF THE KENTUCKY PUBLIC SERVICE COMMISSION

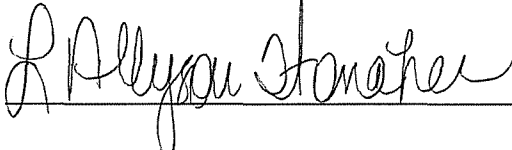
By: (print name) L. Allyson Honaker
By: (sign name) 
Title: Staff Attorney
Date: 10/24/11