

BRIGGS LAW OFFICE, PSC

1301 Clear Springs Trace | Suite 205 | Louisville, Kentucky 40223
Telephone [502] 412-9222 | Facsimile [866] 333-4563
todd@briggslawoffice.net

TODD R. BRIGGS
also admitted in Colorado

May 31, 2011

Via FedEx Overnight Delivery

RECEIVED

JUN 01 2011

PUBLIC SERVICE
COMMISSION

Kentucky Public Service Commission
Attn: Linda Faulkner
Director, Division of Filings
211 Sower Boulevard
Frankfort, KY 40602

**RE: Application to Construct Wireless Communications Facility
Case Number: 2011-00168**

Dear Ms. Faulkner,

On behalf of my client, New Cingular Wireless PCS, LLC, we are hereby submitting an original and five (5) copies of an Application for Certificate of Public Convenience and Necessity to Construct a Wireless Communications Facility.

Please contact me if you require any further documentation or have any questions concerning this application.

Sincerely,



Todd R. Briggs
Counsel for New Cingular Wireless PCS, LLC

Enclosures

COMMONWEALTH OF KENTUCKY
BEFORE THE PUBLIC SERVICE COMMISSION

RECEIVED

JUN 01 2011

PUBLIC SERVICE
COMMISSION

In the Matter of:

APPLICATION OF NEW CINGULAR WIRELESS PCS, LLC)
FOR ISSUANCE OF A CERTIFICATE OF PUBLIC)
CONVENIENCE AND NECESSITY TO CONSTRUCT)
A WIRELESS COMMUNICATIONS FACILITY AT)CASE: 2011-00168
174 NEW LIBERTY CHURCH ROAD, KEVIL)
BALLARD COUNTY, KENTUCKY, 42053)

SITE NAME: KEVIL (EV3166)

**APPLICATION FOR CERTIFICATE
OF PUBLIC CONVENIENCE AND NECESSITY
TO CONSTRUCT A WIRELESS COMMUNICATIONS FACILITY**

New Cingular Wireless PCS, LLC, a Delaware limited liability company, ("Applicant"), by counsel, pursuant to (i) KRS §§ 278.020, 278.040, 278.665 and the rules and regulations applicable thereto, and (ii) the Telecommunications Act of 1996, respectfully submits this Application requesting the issuance of a Certificate of Public Convenience and Necessity ("CPCN") from the Kentucky Public Service Commission ("PSC") to construct, maintain and operate a Wireless Communications Facility ("WCF") to serve the customers of the Applicant with wireless telecommunication services. In support of this Application, Applicant respectfully provides and states the following:

1. The complete name and address of the Applicant is: New Cingular Wireless PCS, LLC d/b/a AT&T Mobility, a Delaware limited liability company having a local address of 601 West Chestnut Street, Louisville, Kentucky 40203.

2. Applicant is a Delaware limited liability company and copies of its Delaware Certificate of Formation and Certificate of Amendment are attached as

Exhibit A. A copy of the Certificate of Authorization to transact business in the Commonwealth of Kentucky is also included as a part of **Exhibit A.**

3. Applicant proposes construction of an antenna tower in Ballard County, Kentucky, in an area which is outside the jurisdiction of a planning commission and Applicant submits the Application to the PSC for a CPCN pursuant to KRS §§ 278.020(1), 278.650, and 278.665. Ballard County does not have a planning commission. This information was verified by the Office of the Ballard County Judge Executive.

4. The public convenience and necessity require the construction of the proposed WCF. The construction of the WCF will bring or improve the Applicant's services to an area currently not served or not adequately served by the Applicant by enhancing coverage and/or capacity and thereby increasing the public's access to wireless telecommunication services. A statement from Applicant's RF Design Engineer outlining said need is attached as **Exhibit N.** The WCF is an integral link in the Applicant's network design that must be in place to provide adequate coverage to the service area.

5. To address the above-described service needs, Applicant proposes to construct a WCF at 174 New Liberty Church Road, Kevil, Kentucky 42053 (37° 4' 55.854" North Latitude, 88° 52' 56.943" West Longitude (NAD 83)), in an area entirely within Ballard County. The property in which the WCF will be located is currently owned by Paul Richard Owen, pursuant to that Deed of record in Deed Book 93, Page 263 in the Office of the Ballard County Clerk. The proposed WCF will consist of a 195 foot monopole with an approximately 4-foot tall lightning arrestor attached to the top of the tower for a total height of 199 feet. The WCF will also include concrete foundations to accommodate the placement of a prefabricated equipment shelter. The WCF compound will be fenced and all access gate(s) will be secured. A detailed site development plan and survey,

signed and sealed by a professional land surveyor registered in Kentucky is attached as **Exhibit B**.

6. A detailed description of the manner in which the WCF will be constructed is included in the site plan and a vertical tower profile signed and sealed by a professional engineer registered in Kentucky is attached as **Exhibit C**. Foundation design plans and a description of the standards according to which the tower was designed which have been signed and sealed by a professional engineer registered in Kentucky are attached as **Exhibit D**.

7. A geotechnical engineering report was performed at the WCF site by Environmental Corporation of America of Alpharetta, Georgia, dated March 15, 2011 and is attached as **Exhibit E**. The name and address of the geotechnical engineering firm and the professional engineer registered in Kentucky who prepared the report are included as part of **Exhibit E**.

8. A list of public utilities, corporations, and/or persons with whom the proposed WCF is likely to compete is attached as **Exhibit F**. Maps of suitable scale showing the location of the proposed WCF as well as the location of any like facilities owned by others located anywhere within the map area are also included in **Exhibit F**.

9. Filing with the Federal Aviation Administration ("FAA") is not necessary due to the height of the proposed tower. The Notice Criteria Tool document is attached as **Exhibit G**. The Kentucky Airport Zoning Commission does not require a permit for the proposed tower. Verification from John Houlihan, Administrator for the Kentucky Airport Zoning Commission, is included as part of **Exhibit G**.

10. The Applicant operates on frequencies licensed by the Federal Communications Commission ("FCC") pursuant to applicable federal

requirements. Copies of the license(s) are attached as **Exhibit H**. The WCF has been designed, and will be built and operated in accordance with all applicable FCC and FAA regulations as indicated in the statement from Applicant's RF Design Engineer included as **Exhibit N**. Appropriate FCC required signage will be posted on the site.

11. Based on the review of Federal Emergency Management Agency Flood Insurance Rate Map, the licensed, professional land surveyor has noted in **Exhibit B** that the Flood Insurance Rate Map (FIRM) No. 2102680125B dated September 29, 1989, indicates that the proposed WCF is not located within any flood hazard area.

12. Personnel directly responsible for the design and construction of the proposed WCF are well qualified and experienced. Project Manager for the site is Chad Goughnour, of Nsoro, Inc.

13. Clear directions to the proposed WCF site from the county seat are attached as **Exhibit I**, including the name and telephone number of the preparer. A copy of the lease for the property on which the tower is proposed to be located is included as part of **Exhibit I**.

14. Applicant has notified, by certified mail, return receipt requested, every person of the proposed construction who, according to the records of the Ballard County Property Valuation Administrators, owns property which is within 500 feet of the proposed tower or is contiguous to the site property. Applicant included in said notices the docket number under which the Application will be processed and informed each person of his or her right to request intervention. A list of the property owners who received notices along with the notices are attached as **Exhibit J**.

15. Applicant has notified the Ballard County Judge Executive by certified mail, return receipt requested, of the proposed construction. The notice included the docket number under which the Application will be processed and informed the Ballard County Judge Executive of his right to request intervention. A copy of the notice is attached as **Exhibit K**.

16. Pursuant to 807 KAR 5:063, Applicant affirms that two notice signs measuring at least two feet by four feet in size with all required language in letters of required height have been posted in a visible location on the proposed site and on the nearest road. Copies of the signs are attached as **Exhibit L**. Such signs shall remain posted for at least two weeks after filing the Application. Notice of the proposed construction has been posted in a newspaper of general circulation in the county in which the construction is proposed (*Advance Yeoman*).

17. The site of the proposed WCF is located in a mixed-use area near Kevil, Kentucky.

18. Applicant has considered the likely effects of the proposed construction on nearby land uses and values and has concluded that there is no more suitable location reasonably available from which adequate service to the area can be provided. Applicant carefully evaluated locations within the search area for co-location opportunities and found no suitable towers or other existing structures that met the requirements necessary in providing adequate service to the area. A statement from Applicant's RF Design Engineer is attached as **Exhibit N**. When suitable towers or structures exist, Applicant has attempted to co-locate on towers designed to host multiple wireless service providers' facilities or existing structures, such as a telecommunications tower or another suitable structure capable of supporting the Applicant's facilities.

19. A map of the area in which the proposed WCF is located, that is drawn to scale and that clearly depicts the search area in which a site should, pursuant to radio frequency requirements, be located is attached as **Exhibit M**.

20. Correspondence and communication with regard to this Application should be directed to:

Todd R. Briggs
Briggs Law Office, PSC
1301 Clear Springs Trace
Suite 205
Louisville, KY 40223
(502) 412-9222
todd@briggslawoffice.net

WHEREFORE, Applicant respectfully requests that the PSC accept the foregoing application for filing and enter an order granting a Certificate of Public Convenience and Necessity to Applicant for construction and operation of the proposed WCF and providing for such other relief as is necessary and appropriate.

Respectfully submitted,

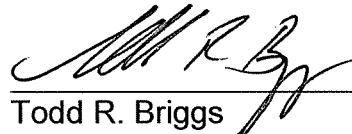

Todd R. Briggs
Briggs Law Office, PSC
1301 Clear Springs Trace
Suite 205
Louisville, KY 40223
Telephone 502-412-9222
Counsel for New Cingular Wireless PCS, LLC

Mary K. Keyer
General Attorney
AT&T Kentucky
601 W. Chestnut Street
Room 407
Louisville, KY 40203

LIST OF EXHIBITS

Exhibit A	Certificate of Authorization
Exhibit B	Site Development Plan and Survey
Exhibit C	Vertical Tower Profile
Exhibit D	Structural and Foundation Design Report
Exhibit E	Geotechnical Engineering Report
Exhibit F	Competing Utilities List and Map of Like Facilities, General Area
Exhibit G	FAA Notice Criteria Tool KAZC Approval
Exhibit H	FCC Documentation
Exhibit I	Directions to Site and Copy of Lease Agreement
Exhibit J	Notification Listing and Copy of Property Owner Notifications
Exhibit K	Copy of County Judge Executive Notice
Exhibit L	Copy of Posted Notices
Exhibit M	Map of Search Area
Exhibit N	RF Engineer Statements

Exhibit A

Commonwealth of Kentucky
Trey Grayson, Secretary of State

Trey Grayson
Secretary of State
P. O. Box 718
Frankfort, KY 40602-0718
(502) 564-3490
<http://www.sos.ky.gov>

Certificate of Authorization

Authentication number: 104309
Visit <http://apps.sos.ky.gov/business/obdb/certvalidate.aspx> to authenticate this certificate.

I, Trey Grayson, Secretary of State of the Commonwealth of Kentucky, do hereby certify that according to the records in the Office of the Secretary of State,

NEW CINGULAR WIRELESS PCS, LLC

, a limited liability company authorized under the laws of the state of Delaware, is authorized to transact business in the Commonwealth of Kentucky, and received the authority to transact business in Kentucky on October 14, 1999.

I further certify that all fees and penalties owed to the Secretary of State have been paid; that an application for certificate of withdrawal has not been filed; and that the most recent annual report required by KRS 275.190 has been delivered to the Secretary of State.

IN WITNESS WHEREOF, I have hereunto set my hand and affixed my Official Seal at Frankfort, Kentucky, this 30th day of September, 2010, in the 219th year of the Commonwealth.



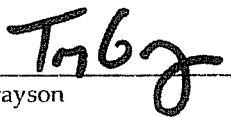

Trey Grayson
Secretary of State
Commonwealth of Kentucky
104309/0481848

Delaware

PAGE 1

The First State

I, HARRIET SMITH WINDSOR, SECRETARY OF STATE OF THE STATE OF DELAWARE, DO HEREBY CERTIFY THE ATTACHED IS A TRUE AND CORRECT COPY OF THE CERTIFICATE OF AMENDMENT OF "AT&T WIRELESS PCS, LLC", CHANGING ITS NAME FROM "AT&T WIRELESS PCS, LLC" TO "NEW CINGULAR WIRELESS PCS, LLC", FILED IN THIS OFFICE ON THE TWENTY-SIXTH DAY OF OCTOBER, A.D. 2004, AT 11:07 O'CLOCK A.M.

AND I DO HEREBY FURTHER CERTIFY THAT THE EFFECTIVE DATE OF THE AFORESAID CERTIFICATE OF AMENDMENT IS THE TWENTY-SIXTH DAY OF OCTOBER, A.D. 2004, AT 7:30 O'CLOCK P.M.

2445544 8100

040770586



Harriet Smith Windsor
Harriet Smith Windsor, Secretary of State

AUTHENTICATION: 3434823

DATE: 10 26 04

State of Delaware
Secretary of State
Division of Corporations
Delivered 11:20 AM 10/26/2004
FILED 11:07 AM 10/26/2004
SRV 040770586 - 2445544 FILE

CERTIFICATE OF AMENDMENT
TO THE CERTIFICATE OF FORMATION
OF
AT&T WIRELESS PCS, LLC

1. The name of the limited liability company is AT&T Wireless PCS, LLC (the "Company").
2. The Certificate of Formation of the Company is amended by deleting the first paragraph in its entirety and replacing it with a new first paragraph to read as follows:

"FIRST: The name of the limited liability company is New Cingular Wireless PCS, LLC."
3. The Certificate of Amendment shall be effective at 7:30 p.m. EDT on October 26, 2004.

[Signature on following page]

IN WITNESS WHEREOF, AT&T Wireless PCS, LLC has caused this Certificate of Amendment to be executed by its duly authorized Manager this 20th day of October, 2004.

AT&T WIRELESS PCS, LLC

By: Cingular Wireless LLC, its Manager

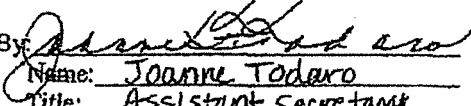
By: 
Name: Joanne Todaro
Title: Assistant Secretary

STATE OF DELAWARE
CERTIFICATE OF FORMATION OF
AT&T WIRELESS PCS, LLC

The undersigned authorized person hereby executes the following Certificate of Formation for the purpose of forming a limited liability company under the Delaware Limited Liability Company Act.

FIRST: The name of the limited liability company is AT&T Wireless PCS, LLC.

SECOND: The address of its registered office in the State of Delaware is Corporation Trust Center, 1209 Orange Street, Wilmington, Delaware 19801. The name of its registered agent at such address is The Corporation Trust Company.

DATED this 7 day of September, 1999.

AT&T WIRELESS SERVICES, INC.,
As Authorized Person



Mark U. Thomas, Vice President

Exhibit B

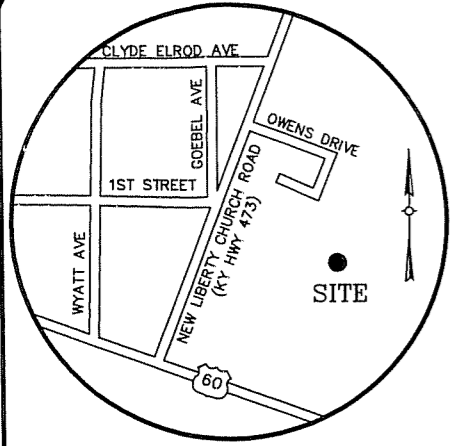

LOCATION MAP
KEVIL, BALLARD CO., KY
NOT TO SCALE

BENCHMARK
NORTH: 1928357.37
EAST: 726707.08
ELEVATION: 418.07 (NAVD 88)
LOCATION: #5 REBAR WITH CAP
"BTM TRAVERSE"

**COORDINATE POINT LOCATION
PROPOSED TOWER CENTERLINE**
NAD 1983
LATITUDE: 37°04'55.854"N
LONGITUDE: 88°52'56.943"W
ELEVATION: 429.24 (NAVD 88)
STATE PLANE COORDINATE
NORTHING: 1928208.69
EASTING: 726823.59

- LEGEND**
- x — x — EXISTING FENCE LINE
 - DHU — EXISTING OVERHEAD UTILITIES
 - — — LEASE LINE
 - - - - - APPROXIMATE PROPERTY LINE
 - GUY ANCHOR
 - UTILITY POLE
 - FOUND #4 REBAR UNLESS OTHERWISE NOTED
 - SET #5 REBAR WITH CAP STAMPED "TODD LOPP #3917" UNLESS OTHERWISE NOTED
 - POC POINT OF COMMENCEMENT
 - POB POINT OF BEGINNING
 - IE INVERT ELEVATION
 - CMP CORRUGATED METAL PIPE
 - CLEANOUT

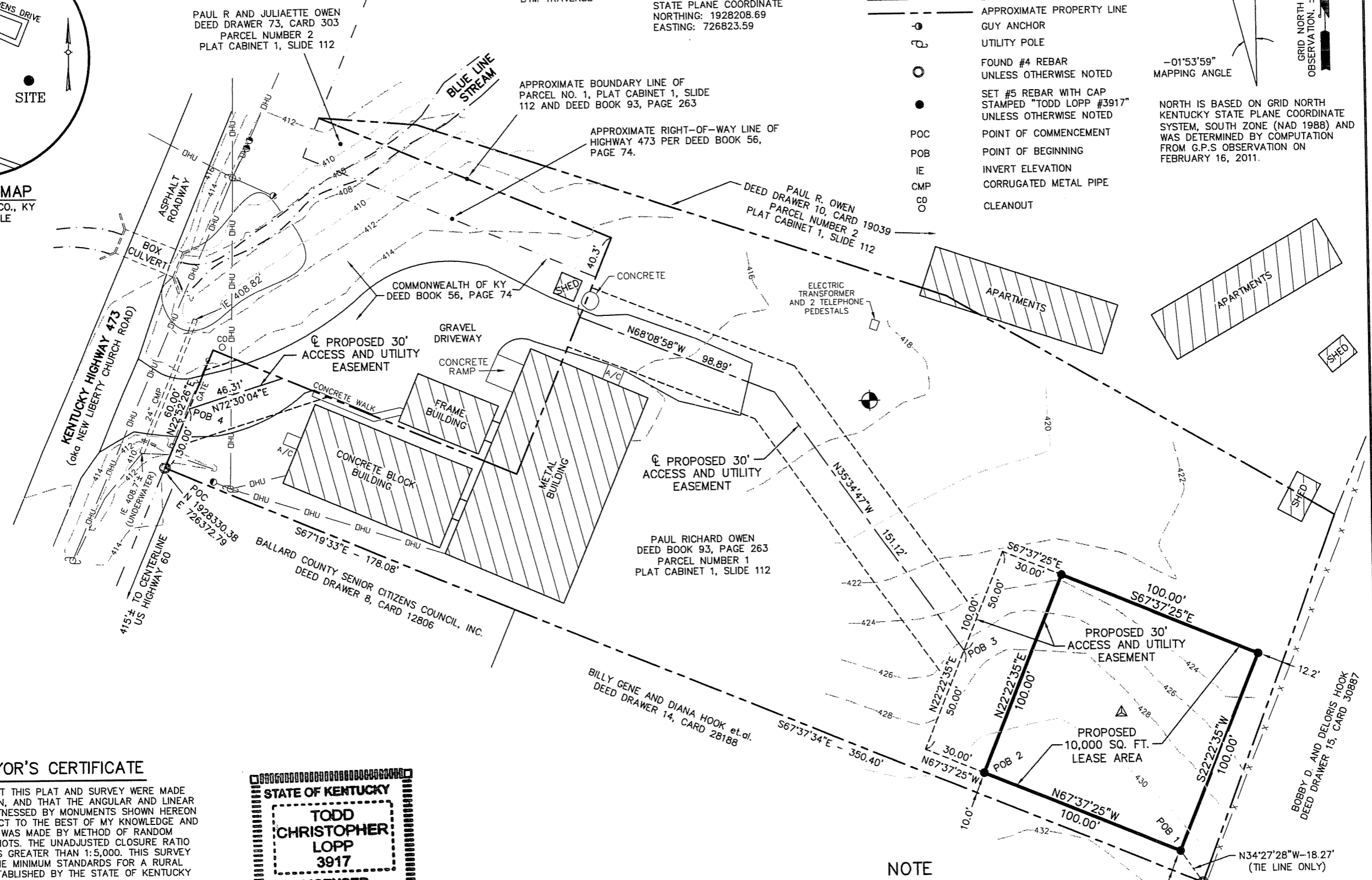
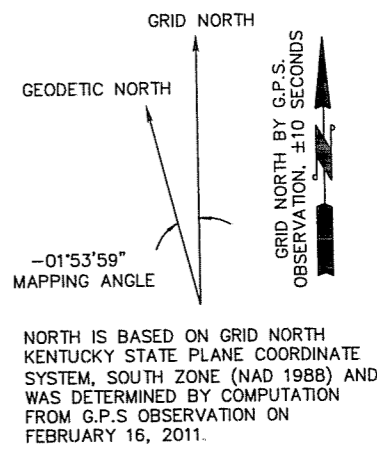

LAND SURVEYOR'S CERTIFICATE

I HEREBY CERTIFY THAT THIS PLAT AND SURVEY WERE MADE UNDER MY SUPERVISION, AND THAT THE ANGULAR AND LINEAR MEASUREMENTS AS WITNESSED BY MONUMENTS SHOWN HEREON ARE TRUE AND CORRECT TO THE BEST OF MY KNOWLEDGE AND BELIEF. THIS SURVEY WAS MADE BY METHOD OF RANDOM TRAVERSE WITH SIDESHOTS. THE UNADJUSTED CLOSURE RATIO OF THE TRAVERSE WAS GREATER THAN 1:5,000. THIS SURVEY MEETS OR EXCEEDS THE MINIMUM STANDARDS FOR A RURAL CLASS SURVEY AS ESTABLISHED BY THE STATE OF KENTUCKY PER 201 KAR 18:150.

Todd Lopp 5-13-11
TODD C. LOPP, PLS 3917 DATE

OWNER APPROVAL: _____ DATE

AT&T APPROVAL: _____ DATE



FLOOD PLAIN CERTIFICATION

I HAVE REVIEWED THE FLOOD INSURANCE RATE MAPS (FIRM) MAP NO. 2102680125B DATED SEPTEMBER 29, 1989 AND THE LEASE AREA DOES NOT APPEAR TO BE IN A FLOOD HAZARD AREA.

NOTE
1. THIS SURVEY IS SUBJECT TO ALL EXISTING EASEMENTS, RESTRICTIONS, EXCEPTIONS, SERVITUDE'S, RIGHT OF WAYS AND PRIOR LEASES WHETHER SHOWN HEREON OR NOT. A TITLE REPORT MAY REVEAL EASEMENTS OR OTHER DEFECTS WHETHER SHOWN HEREON OR NOT.

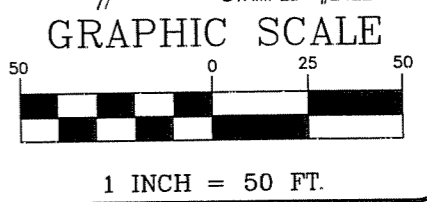

SEE SHEET C-2A FOR LEGAL DESCRIPTIONS



BTM ENGINEERING, INC.
3001 TAYLOR SPRINGS DRIVE
LOUISVILLE, KENTUCKY 40220
(502) 459-8402 PHONE
(502) 459-8427 FAX

SITE NAME: KEVIL

SITE I.D.: EV3166

SITE ADDRESS:
174 NEW LIBERTY CHURCH ROAD
KEVIL, BALLARD CO., KY 42053

LEASE AREA: 10,000 SQ. FT.

PROPERTY OWNER:
PAUL RICHARD OWEN
PO BOX 190
KEVIL, KY 42053

TAX MAP NUMBER: 64

PARCEL NUMBER: 60

SOURCE OF TITLE:
DEED BOOK 93, PAGE 263

LATITUDE: 37° 04' 55.854"N
LONGITUDE: 88° 52' 56.943"W

NO.	REVISION/ISSUE	DATE
1	ISSUE	4/6/11
2	UPDATE ADJOINER	5/18/11

TITLE:
**COMMUNICATIONS
SITE SURVEY**

SHEET:
C-2



BTM ENGINEERING, INC.
3001 TAYLOR SPRINGS DRIVE
LOUISVILLE, KENTUCKY 40220
(502) 459-8402 PHONE
(502) 459-8427 FAX

LEGAL DESCRIPTIONS

THIS IS THE DESCRIPTION FOR AT&T, FOR AN AREA TO BE LEASED FROM A TRACT OF LAND CONVEYED TO PAUL RICHARD OWEN BY DEED OF RECORD IN DEED BOOK 93, PAGE 263 IN THE OFFICE OF THE COUNTY CLERK OF BALLARD COUNTY, KENTUCKY AND FURTHER DESCRIBED AS FOLLOWS:

DESCRIPTION OF PROPOSED LEASE AREA AND EASEMENTS

NOTE: ALL BEARINGS AND DISTANCES ARE BASED ON GRID NORTH KENTUCKY STATE PLANE COORDINATE SYSTEM SOUTH ZONE NAD 1983.

COMMENCING AT A FOUND #4 REBAR AT KENTUCKY STATE PLANE COORDINATE, NORTH 1928330.38 AND EAST 726372.79 IN THE EXISTING EAST RIGHT OF WAY OF KENTUCKY HIGHWAY 473 (aka NEW LIBERTY CHURCH ROAD), ALSO BEING THE SOUTHWEST PROPERTY CORNER OF THE TRACT OF LAND CONVEYED TO PAUL RICHARD OWEN BY DEED OF RECORD IN DEED BOOK 93, PAGE 263 IN THE OFFICE OF THE COUNTY CLERK OF BALLARD COUNTY, KENTUCKY; SAID POINT OF COMMENCEMENT BEING LOCATED APPROXIMATELY 415 FEET NORTHEAST OF THE EXISTING CENTERLINE OF US HIGHWAY 60. THENCE S67°19'33"E, 178.08 FEET; THENCE S67°37'34"E, 350.40 FEET TO A FOUND #4 REBAR WITH CAP STAMPED "#2422"; THENCE N34°27'28"W, 18.27 FEET TO A SET REBAR #5 REBAR WITH CAP STAMPED "TODD LOPP #3917" (HEREAFTER REFERRED TO AS SET REBAR) AT THE POINT OF BEGINNING 1; THENCE WITH THE PROPOSED LEASE AREA THE NEXT FOUR CALLS, N67°37'25"W, 100.00 FEET TO A SET REBAR; THENCE N22°22'35"E, 100.00 FEET TO A SET REBAR; THENCE S67°37'25"E, 100.00 FEET TO A SET REBAR; THENCE S22°22'35"W, 100.00 FEET TO THE POINT OF BEGINNING 1 AND CONTAINING 10,000 SQUARE FEET.

ALSO, THE RIGHT TO USE FOR ACCESS AND UTILITIES TO THE ABOVE DESCRIBED LEASE AREA, A 30 FOOT WIDE EASEMENT BEING DESCRIBED AS FOLLOWS: COMMENCING AT A FOUND #4 REBAR AT KENTUCKY STATE PLANE COORDINATE, NORTH 1928330.38 AND EAST 726372.79 IN THE EXISTING EAST RIGHT OF WAY OF KENTUCKY HIGHWAY 473 (aka NEW LIBERTY CHURCH ROAD), ALSO BEING THE SOUTHWEST PROPERTY CORNER OF THE TRACT OF LAND CONVEYED TO PAUL RICHARD OWEN BY DEED OF RECORD IN DEED BOOK 93, PAGE 263 IN THE OFFICE OF THE COUNTY CLERK OF BALLARD COUNTY, KENTUCKY; SAID POINT OF COMMENCEMENT BEING LOCATED APPROXIMATELY 415 FEET NORTHEAST OF THE EXISTING CENTERLINE OF US HIGHWAY 60. THENCE S67°19'33"E, 178.08 FEET; THENCE S67°37'34"E, 350.40 FEET TO A FOUND #4 REBAR WITH CAP STAMPED "#2422"; THENCE N34°27'28"W, 18.27 FEET; THENCE N67°37'25"W, 100.00 FEET TO THE POINT OF BEGINNING 2; THENCE WITH SAID EASEMENT THE FOLLOWING FOUR CALLS, N67°37'25"W, 30.00 FEET; THENCE N22°22'35"E, 100.00 FEET; THENCE S67°37'25"E, 30.00 FEET; THENCE S22°22'35"W, 100.00 FEET TO THE POINT OF BEGINNING 2.

ALSO, THE RIGHT TO USE FOR ACCESS AND UTILITIES TO THE ABOVE DESCRIBED LEASE AREA, A 30 FOOT WIDE EASEMENT THE CENTERLINE BEING DESCRIBED AS FOLLOWS: COMMENCING AT A FOUND #4 REBAR AT KENTUCKY STATE PLANE COORDINATE, NORTH 1928330.38 AND EAST 726372.79 IN THE EXISTING EAST RIGHT OF WAY OF KENTUCKY HIGHWAY 473 (aka NEW LIBERTY CHURCH ROAD), ALSO BEING THE SOUTHWEST PROPERTY CORNER OF THE TRACT OF LAND CONVEYED TO PAUL RICHARD OWEN BY DEED OF RECORD IN DEED BOOK 93, PAGE 263 IN THE OFFICE OF THE COUNTY CLERK OF BALLARD COUNTY, KENTUCKY; SAID POINT OF COMMENCEMENT BEING LOCATED APPROXIMATELY 415 FEET NORTHEAST OF THE EXISTING CENTERLINE OF US HIGHWAY 60. THENCE S67°19'33"E, 178.08 FEET; THENCE S67°37'34"E, 350.40 FEET TO A FOUND #4 REBAR WITH CAP STAMPED "#2422"; THENCE N34°27'28"W, 18.27 FEET; THENCE N67°37'25"W, 130.00 FEET; THENCE N22°22'35"E, 50.00 FEET TO THE POINT OF BEGINNING 3; THENCE WITH SAID EASEMENT CENTERLINE THE FOLLOWING TWO CALLS, N35°34'47"W, 151.12 FEET; THENCE N68°08'58"W, 98.89 FEET TO THE TERMINATION OF SAID EASEMENT CENTERLINE IN SAID EAST RIGHT OF WAY OF KENTUCKY HIGHWAY 473.

ALSO, THE RIGHT TO USE FOR ACCESS AND UTILITIES TO THE ABOVE DESCRIBED LEASE AREA, A 30 FOOT WIDE EASEMENT THE CENTERLINE BEING DESCRIBED AS FOLLOWS: COMMENCING AT A FOUND #4 REBAR AT KENTUCKY STATE PLANE COORDINATE, NORTH 1928330.38 AND EAST 726372.79 IN THE EXISTING EAST RIGHT OF WAY OF KENTUCKY HIGHWAY 473 (aka NEW LIBERTY CHURCH ROAD), ALSO BEING THE SOUTHWEST PROPERTY CORNER OF THE TRACT OF LAND CONVEYED TO PAUL RICHARD OWEN BY DEED OF RECORD IN DEED BOOK 93, PAGE 263 IN THE OFFICE OF THE COUNTY CLERK OF BALLARD COUNTY, KENTUCKY; SAID POINT OF COMMENCEMENT BEING LOCATED APPROXIMATELY 415 FEET NORTHEAST OF THE EXISTING CENTERLINE OF US HIGHWAY 60. THENCE WITH THE SAID EAST RIGHT OF WAY LINE OF KENTUCKY HIGHWAY 473 (aka NEW LIBERTY CHURCH ROAD) N22°52'26"E, 30.00 FEET TO THE POINT OF BEGINNING 4; THENCE LEAVING SAID EAST RIGHT OF WAY LINE OF KENTUCKY HIGHWAY 473 AND WITH SAID EASEMENT CENTERLINE, N72°30'04"E, 46.31 FEET TO THE TERMINATION OF SAID EASEMENT CENTERLINE AS SHOWN ON A PARTIAL BOUNDARY SURVEY BY TODD C. LOPP, PLS 3917 OF BTM ENGINEERING, INC, DATED APRIL, 2011, PROJECT NO. "NSORO-KEVIL".

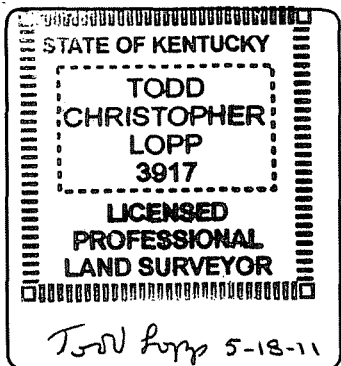

SITE NAME: KEVIL

SITE I.D.: EV3166

SITE ADDRESS: 174 NEW LIBERTY CHURCH ROAD
KEVIL, BALLARD CO., KY 42053

LEASE AREA: 10,000 SQ. FT.

PROPERTY OWNER: PAUL RICHARD OWEN
PO BOX 190
KEVIL, KY 42053

TAX MAP NUMBER: 64

PARCEL NUMBER: 60

SOURCE OF TITLE: DEED BOOK 93, PAGE 263

LATITUDE: 37° 04' 55.854"N
LONGITUDE: 88° 52' 56.943"W

NO.	REVISION/ISSUE	DATE
1	ISSUE	4/6/11
2	UPDATE ADJOINER	5/18/11

TITLE: COMMUNICATIONS
SITE SURVEY

SHEET: C-2A

SITE PLAN NOTES

1. THE PROPOSED DEVELOPMENT IS FOR A 195 FOOT MONOPOLE AND MULTIPLE EQUIPMENT LOCATIONS. ITS LOCATION IS 174 NEW LIBERTY CHURCH RD, KEVIL, KY 42053.
2. THE TOWER WILL BE ACCESSED BY A PROPOSED STABILIZED DRIVE FROM AN EXISTING GRAVEL ROAD (NEW LIBERTY CHURCH RD). WATER, SANITARY SEWER, AND WASTE COLLECTIONS SERVICES ARE NOT REQUIRED FOR THE PROPOSED DEVELOPMENT.
3. CENTERLINE OF PROPOSED TOWER GEOGRAPHIC LOCATIONS:
 LATITUDE: 37° 04' 55.854" N 1928208.69 N
 LONGITUDE: 88° 52' 56.943" W 726823.59 E
4. REMOVE ALL VEGETATION, CLEAN AND GRUBB LEASE AREA (WHERE REQUIRED).
5. FINISH GRADING TO PROVIDE EFFECTIVE DRAINAGE WITH A SLOPE OF NO LESS THAN ONE EIGHTH INCH (1/8") PER FOOT FLOWING AWAY FROM EQUIPMENT FOR A MINIMUM DISTANCE OF SIX FEET (6') IN ALL DIRECTIONS.
6. LOCATE ALL U.G. UTILITIES PRIOR TO ANY CONSTRUCTION.
7. COMPOUND FINISHED SURFACE TO BE FENCED

UNDERGROUND UTILITIES
 CALL 2 WORKING DAYS
BEFORE YOU DIG
 INDIANA 1-800-382-5544
 KENTUCKY 1-800-752-6007
 OR DIAL 811
 UTILITIES PROTECTION SERVICE
 NON-MEMBERS MUST CALL DIRECTLY



BT Engineering, Inc
 3001 TAYLOR SPRINGS DRIVE
 LOUISVILLE, KENTUCKY 40220
 (502) 459-8402 PHONE
 (502) 459-8427 FAX

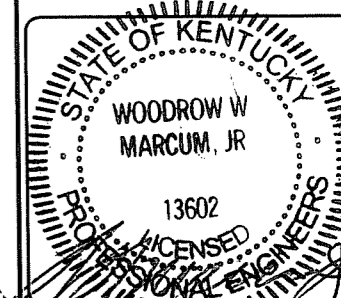

SITE NAME: KEVIL

SITE ID NUMBER: EV3166

SITE ADDRESS:
 174 NEW LIBERTY CHURCH RD
 KEVIL, KY 42053

LATITUDE: 37° 04' 55.854" N
 LONGITUDE: 88° 52' 56.943" W

TAX MAP NUMBER: 64

PARCEL NUMBER: 60

SOURCE OF TITLE:
 DEED DRAWER 73, CARD 303

PROPERTY OWNER:
 PAUL R & JULIAETTE OWEN
 BOX 190
 KEVIL, KY 42053

NO	REVISION/ISSUE	DATE
1	ISSUE FOR COMMENT	03/10/11
2	ISSUE FOR ZONING	05/24/11

TITLE:
OVERALL SITE LAYOUT

SHEET:

Z-2

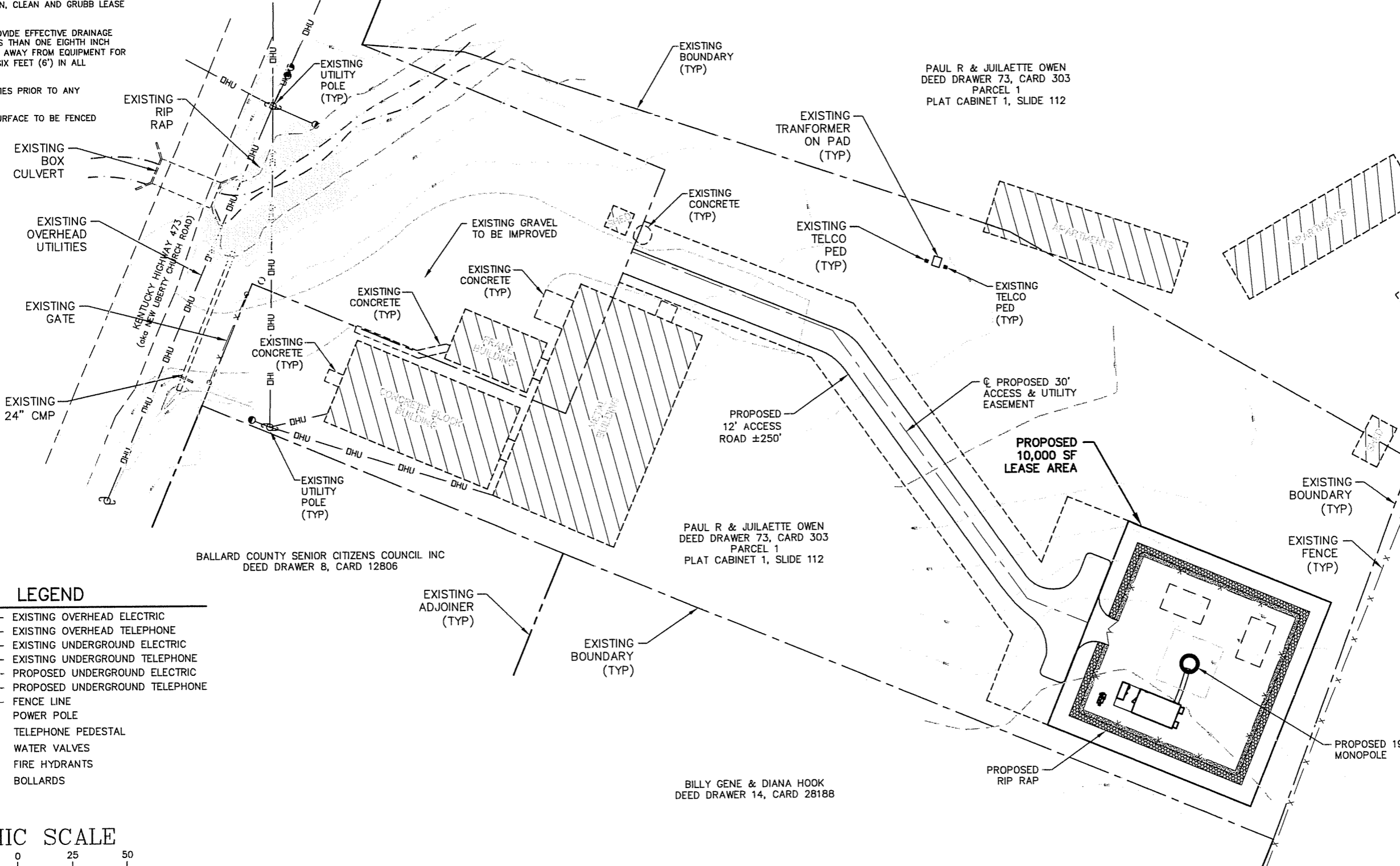

LEGEND

- E—E— EXISTING OVERHEAD ELECTRIC
- T—T— EXISTING OVERHEAD TELEPHONE
- -UE- -UE- EXISTING UNDERGROUND ELECTRIC
- -UT- -UT- EXISTING UNDERGROUND TELEPHONE
- UE—UE— PROPOSED UNDERGROUND ELECTRIC
- UT—UT— PROPOSED UNDERGROUND TELEPHONE
- x-x- FENCE LINE
- ⊙ POWER POLE
- TELE PED
- TELE PED
- WATER VALVES
- FIRE HYDRANTS
- BOLLARDS

GRAPHIC SCALE

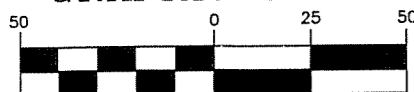

1 INCH = 50 FT.

SITE PLAN NOTES

1. THE PROPOSED DEVELOPMENT IS FOR A 195 FOOT MONOPOLE AND MULTIPLE EQUIPMENT LOCATIONS. ITS LOCATION IS 174 NEW LIBERTY CHURCH RD, KEVIL, KY 42053.
2. THE TOWER WILL BE ACCESSED BY A PROPOSED STABILIZED DRIVE FROM AN EXISTING GRAVEL ROAD (NEW LIBERTY CHURCH RD). WATER, SANITARY SEWER, AND WASTE COLLECTIONS SERVICES ARE NOT REQUIRED FOR THE PROPOSED DEVELOPMENT.
3. CENTERLINE OF PROPOSED TOWER GEOGRAPHIC LOCATIONS:
 LATITUDE: 37° 04' 55.854" N 1928208.69 N
 LONGITUDE: 88° 52' 56.943" W 726823.59 E
4. REMOVE ALL VEGETATION, CLEAN AND GRUBB LEASE AREA (WHERE REQUIRED).
5. FINISH GRADING TO PROVIDE EFFECTIVE DRAINAGE WITH A SLOPE OF NO LESS THAN ONE EIGHTH INCH (1/8") PER FOOT FLOWING AWAY FROM EQUIPMENT FOR A MINIMUM DISTANCE OF SIX FEET (6') IN ALL DIRECTIONS.
6. LOCATE ALL U.G. UTILITIES PRIOR TO ANY CONSTRUCTION.
7. COMPOUND FINISHED SURFACE TO BE FENCED

UNDERGROUND UTILITIES
 CALL 2 WORKING DAYS
BEFORE YOU DIG
 INDIANA 1-800-382-5544
 KENTUCKY 1-800-752-6007
 OR DIAL 811
 UTILITIES PROTECTION SERVICE
 NON-MEMBERS MUST CALL DIRECTLY

LEGEND

- E— EXISTING OVERHEAD ELECTRIC
- T— EXISTING OVERHEAD TELEPHONE
- UE— EXISTING UNDERGROUND ELECTRIC
- UT— EXISTING UNDERGROUND TELEPHONE
- -UE- - - PROPOSED UNDERGROUND ELECTRIC
- -UT- - - PROPOSED UNDERGROUND TELEPHONE
- -X- - - FENCE LINE
- POWER POLE
- TELE PED TELEPHONE PEDESTAL
- ⊗ WATER VALVES
- ⊕ FIRE HYDRANTS
- BOLLARDS

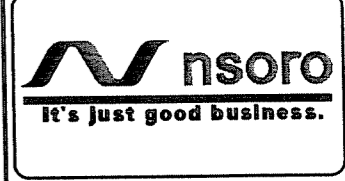
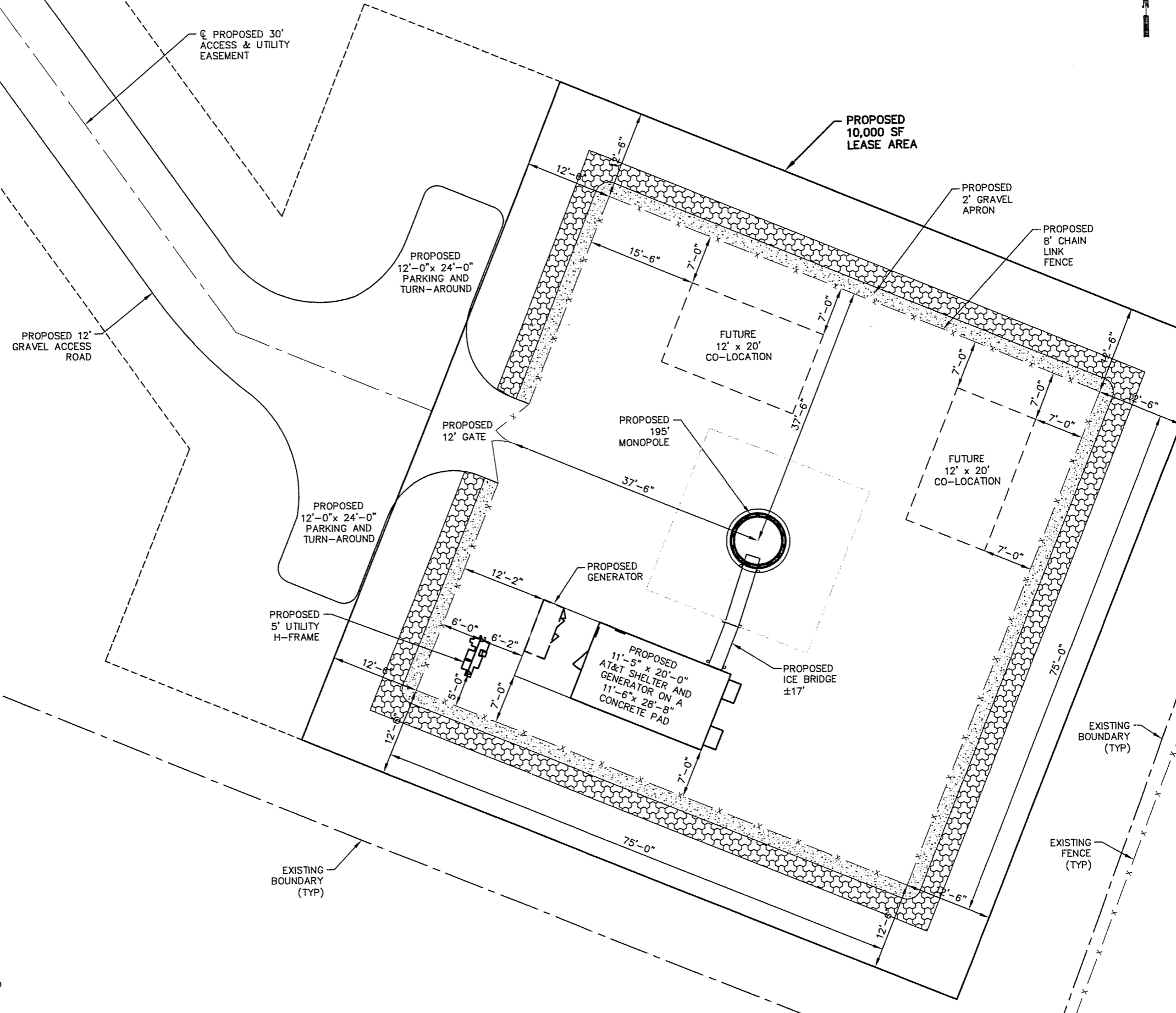
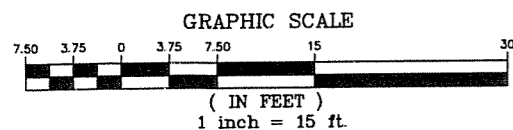

BT Engineering, Inc
 3001 TAYLOR SPRINGS DRIVE
 LOUISVILLE, KENTUCKY 40220
 (502) 459-8402 PHONE
 (502) 459-8427 FAX

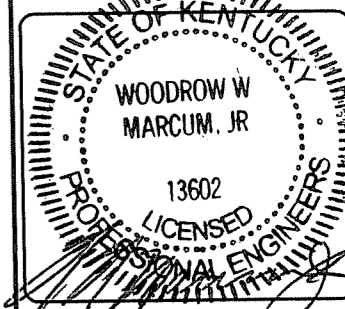

SITE NAME: KEVIL

SITE ID NUMBER: EV3166

SITE ADDRESS:
 174 NEW LIBERTY CHURCH RD
 KEVIL, KY 42053

LATITUDE: 37° 04' 55.854" N
 LONGITUDE: 88° 52' 56.943" W

TAX MAP NUMBER: 64

PARCEL NUMBER: 60

SOURCE OF TITLE:
 DEED DRAWER 73, CARD 303

PROPERTY OWNER:
 PAUL R & JULIAETTE OWEN
 BOX 190
 KEVIL, KY 42053

NO	REVISION/ISSUE	DATE
1	ISSUE FOR COMMENT	03/10/11
2	ISSUE FOR ZONING	05/24/11

TITLE:
SITE LAYOUT

SHEET:
Z-3

Exhibit C



BT Engineering, Inc
 3001 TAYLOR SPRINGS DRIVE
 LOUISVILLE, KENTUCKY 40220
 (502) 459-8402 PHONE
 (502) 459-8427 FAX



SITE NAME: KEVIL

SITE ID NUMBER: EV3166

SITE ADDRESS:
 174 NEW LIBERTY CHURCH RD
 KEVIL, KY 42053

LATITUDE: 37° 04' 55.854" N
 LONGITUDE: 88° 52' 56.943" W

TAX MAP NUMBER: 64

PARCEL NUMBER: 60

SOURCE OF TITLE:
 DEED DRAWER 73, CARD 303

PROPERTY OWNER:
 PAUL R & JULIAETTE OWEN
 BOX 190
 KEVIL, KY 42053

NO	REVISION/ISSUE	DATE
1	ISSUE FOR COMMENT	03/10/11
2	ISSUE FOR ZONING	05/24/11

TITLE:
 NORTH & SOUTH ELEVATIONS

SHEET:
 Z-5

NOTE:
 THE ELEVATIONS SHOWN ON THIS SHEET ARE FOR PICTORIAL PURPOSES ONLY. THIS DESIGN WAS PROVIDED BY OTHERS. REFER TO TOWER PLANS FOR TOWER DESIGN.

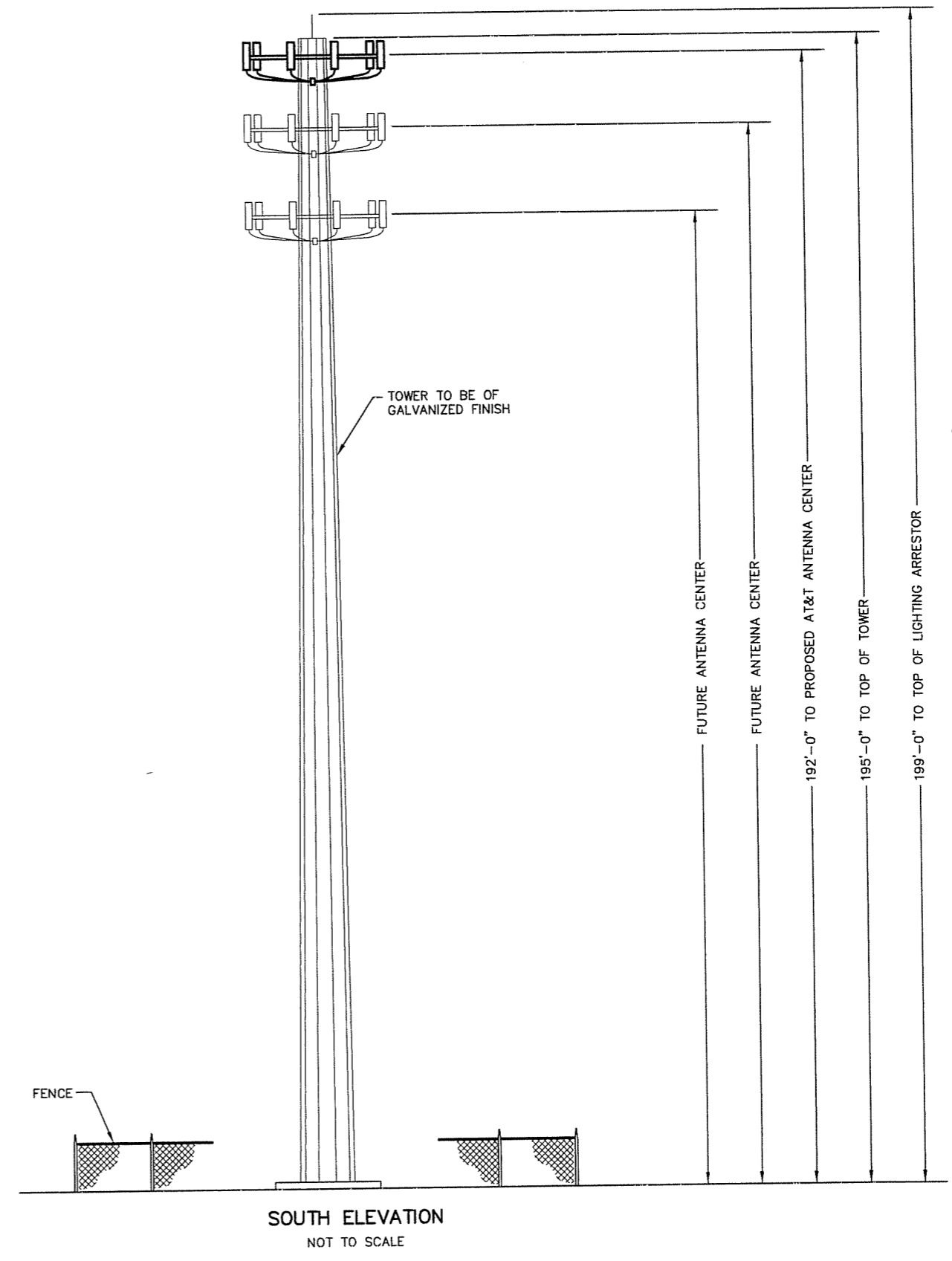
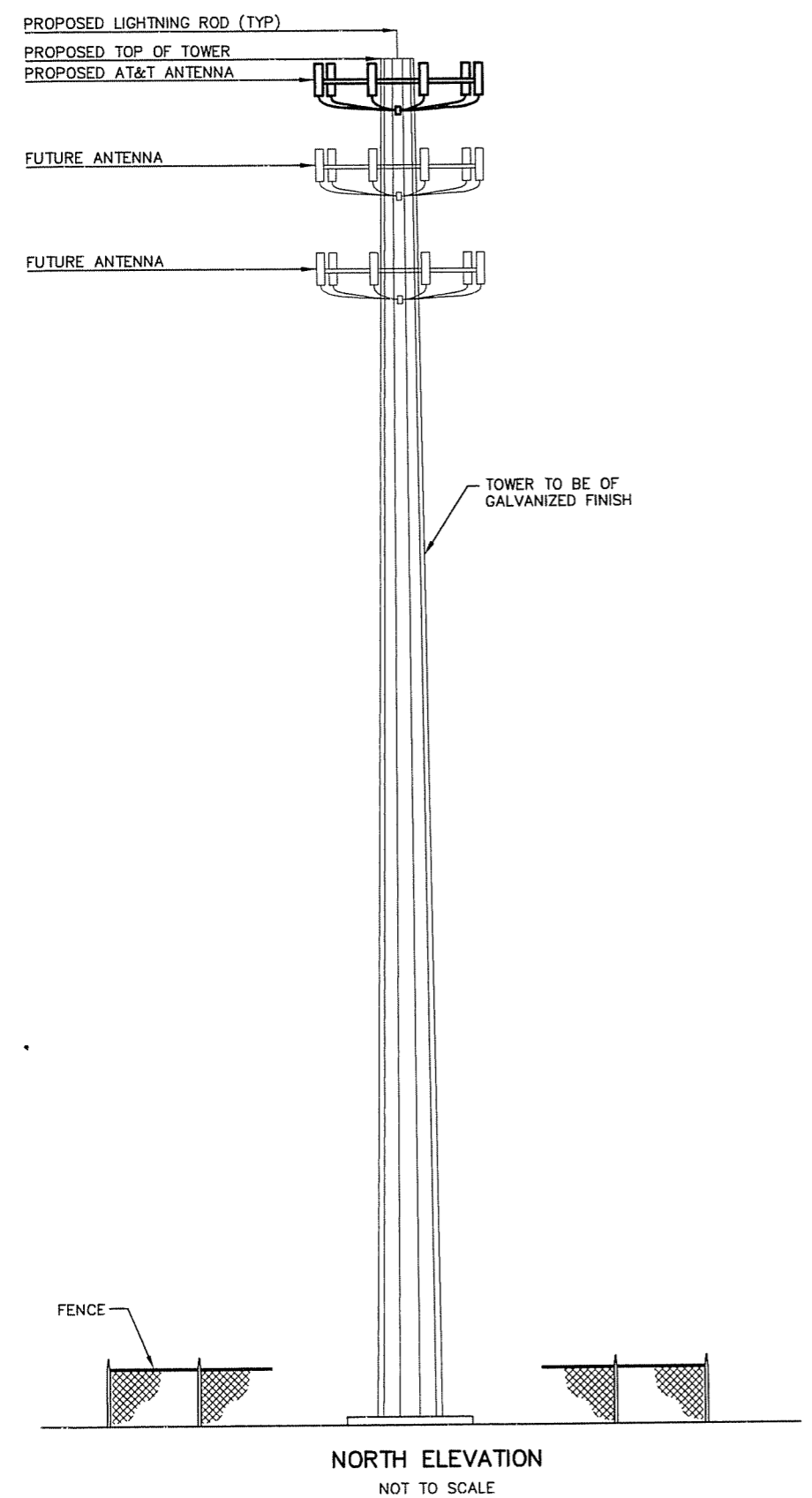
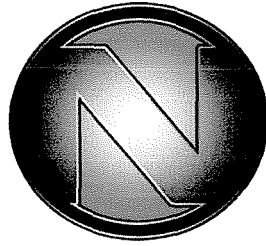

Exhibit D



N E L L O

Tower and Foundation Drawings

Sales Order: 15366
Drawing Number
 Tower: 145307
 Foundation: 145308
Order Description: NTP 81" x 195'
Site Name: Kevil / EV3166
Location: Ballard County, KY

Prepared For:

Customer: Nsoro MasTec, LLC
Contact: Brian K. Distler
Date: May 25, 2011

Table of Contents

Tower Drawing

Foundation Drawing

Foundation Notes

1. This foundation has been designed for the following reactions.

Drilled Pier Design:

Shear: 41.5 kips
 Moment: 5440.1 ft-kips
 Weight: 70.2 kips

Pier and Pad Design:

Shear: 41.5 kips
 Moment: 5440.1 ft-kips
 Weight: 70.2 kips

2. Foundation is designed per soil report dated 03/15/2011, by Environmental Corporation of America, project number M-383-4.

3. A field inspection shall be performed in order to verify that the actual site soil parameters meet or exceed the assumed soil parameters and that the depth of standard foundations are adequate based on the frost penetration and groundwater depth. Local frost depth must be no deeper than the bottom of the base foundation.

4. Reinforcement shall be deformed and conform to the requirements of ASTM A615 Grade 60 unless otherwise noted. Splices in reinforcement shall not be allowed unless otherwise noted.

5. Welding is prohibited on reinforcing steel and anchorage.

6. Structural backfill must be compacted in 12" loose lifts to a 97% of maximum dry density at optimum moisture content in accordance with ASTM D698. Backfill must be clean and free of organic and frozen soils and foreign materials. Fill should be compacted at water content within 2 percent of optimum.

7. Foundation designs assume level ground at tower site.

8. Loose material shall be removed from bottom of excavation prior to concrete placement.

9. Concrete cover from exposed surface of concrete to surface of reinforcement shall not be less than 3".

10. Concrete and reinforcement installation must conform to ACI 318, "Building Code Requirements for Structural Concrete."

11. Concrete shall develop a minimum compressive strength of 4000 psi in 28 days.

12. Concrete shall be placed as soon as practical after excavating to avoid disturbance of bearing and side wall surfaces.

13. Concrete contractor shall be responsible for properly aligning anchor bolts and materials before and after placing concrete, regardless of whether an anchor bolt template is provided.

14. Positive drainage shall be maintained during construction and throughout the life of the facility to minimize the potential for surface water infiltration.

15. A temporary steel casing and/or drilling slurry may be required for installation of the drilled pier foundation.

16. The sub-grade, if practical, should be proof-rolled with vibratory compaction prior to casting foundation or placing structural fill.

17. If unsuitable soils are encountered, overexcavation of unsuitable soils for compacted backfill placement below footings should extend laterally beyond all edges of the footings at least 12 inches per foot of overexcavation depth below footing base elevation.

18. It shall be the contractor's responsibility to locate and prevent damage to any existing underground utilities, foundations or other buried objects that might be damaged or interfered with during construction of the foundation.

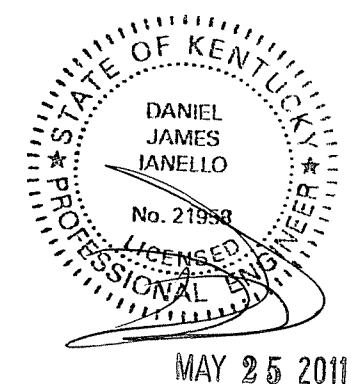

TITLE:
 Nsoro MasTec, LLC
 NTP 81" x 195'
 Kevil/EV3166
 Ballard Co., KY



COPYRIGHT NOTICE:
 This drawing is the property of Nello Inc. It is not to be reproduced, copied or traced in whole or in part without our written consent.

ORIG. DATE: 4/19/2011 DWG NO: 145308
 DWG. PROG: v.2.1 SHEET: 3 OF 3

REV	BY	DATE	DESCRIPTION
1	DF	5/25/2011	Revised foundation reactions

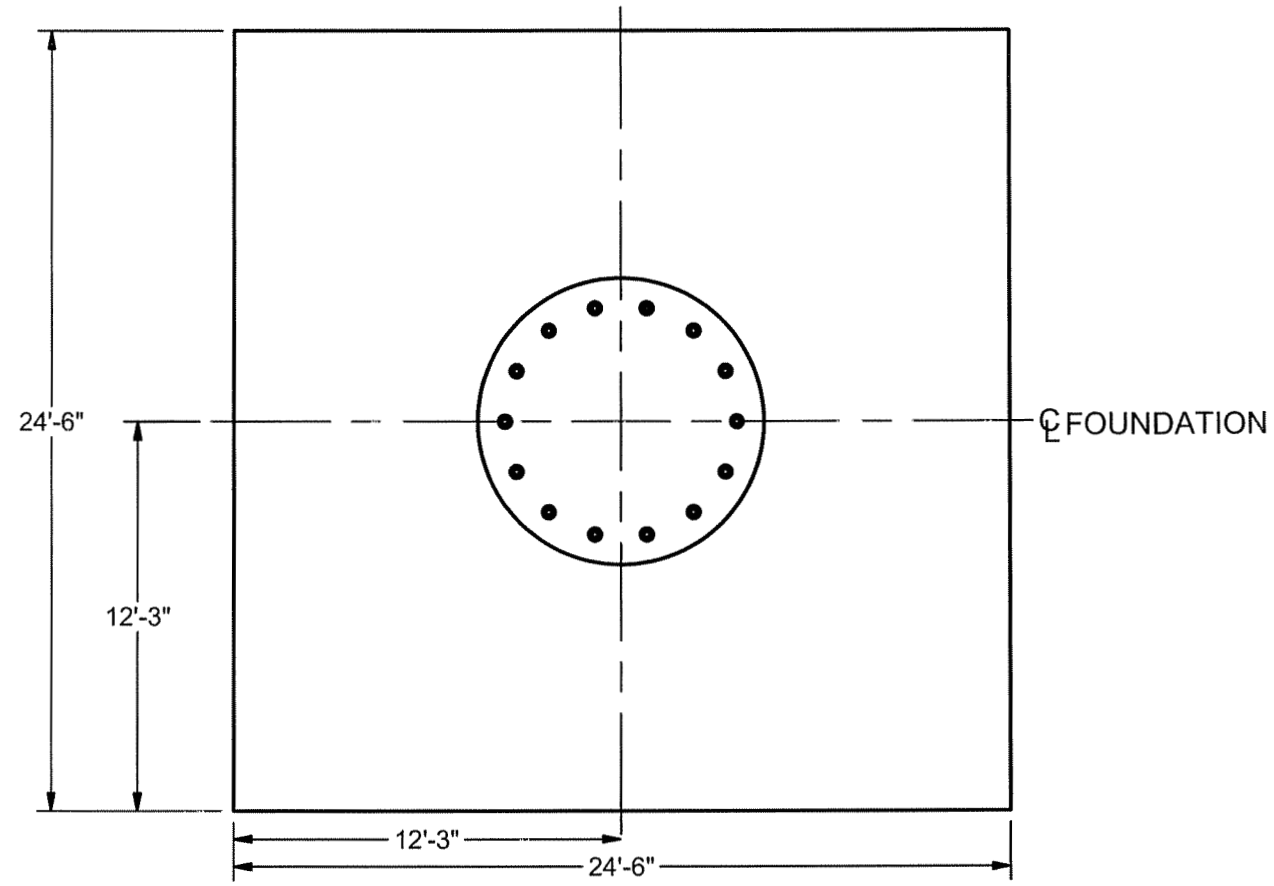

PLAN VIEW
(REINFORCEMENT NOT SHOWN FOR CLARITY)

2.25" dia. X 84" ASTM A615
grade 75 anchor bolts,
P/N 108787,
14 total.

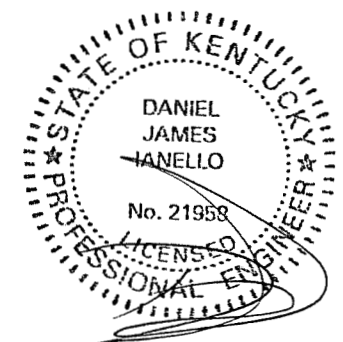
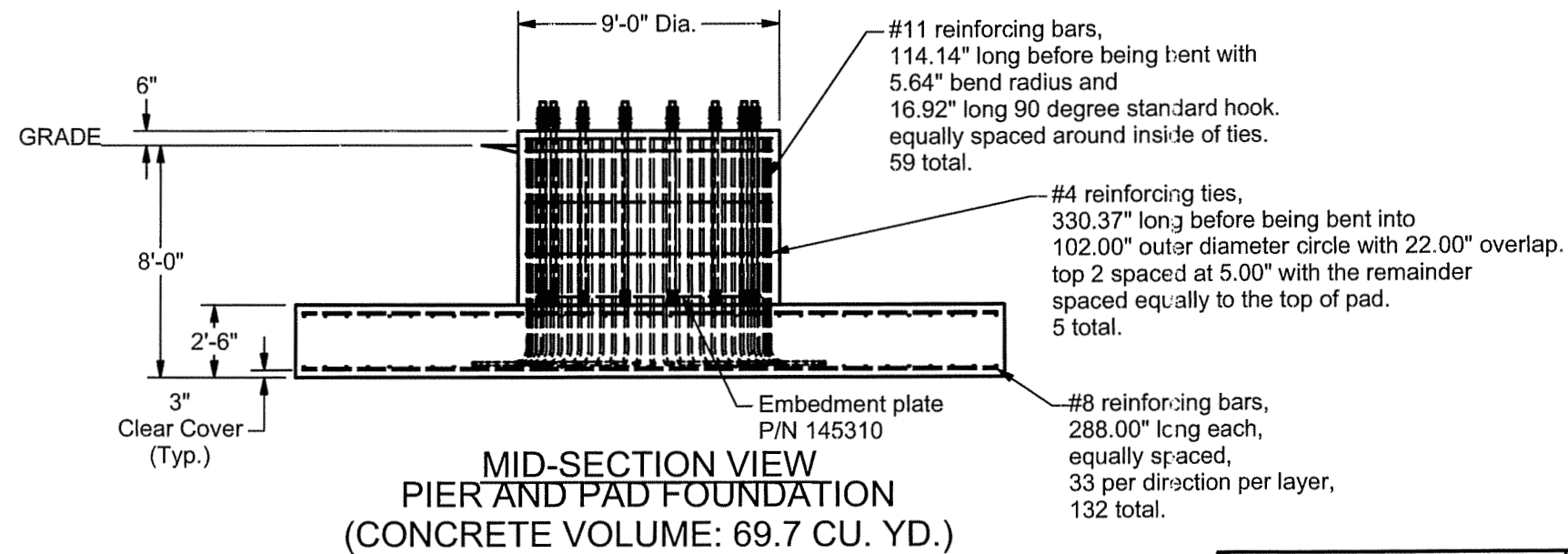
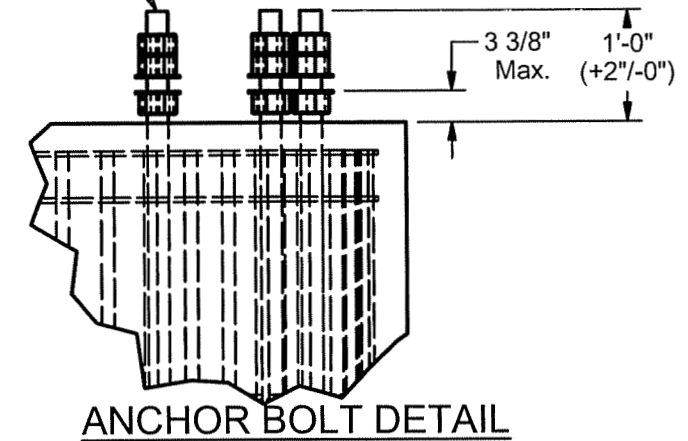

MAY 25 2011

TITLE:
Nsoro MasTec, LLC
NTP 81" x 195'
Kevii/EV3166
Ballard Co., KY

NELLO CORPORATION
211 W. Washington St.,
Suite 2000
South Bend, IN 46601-1705
Bus: (574)288-3632
Fax: (574)288-5860

<p>COPYRIGHT NOTICE: This drawing is the property of Nello Inc. It is not to be reproduced, copied or traced in whole or in part without our written consent.</p>	ORIG. DATE: 4/19/2011	DWG NO: 145308
	DWG. PROG: v.2.1	SHEET: 2 OF 3

REV	BY	DATE	DESCRIPTION
1	DF	5/25/2011	Revised foundation reactions

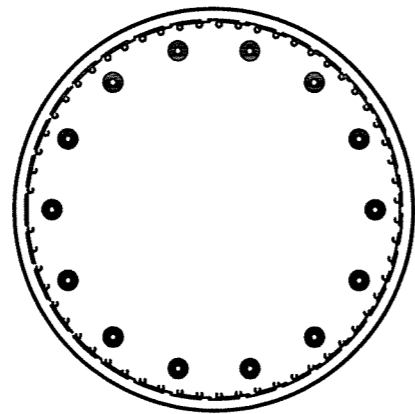

PLAN VIEW

2.25" dia. x 84" ASTM A615
grade 75 anchor bolts,
P/N 108787
14 total.

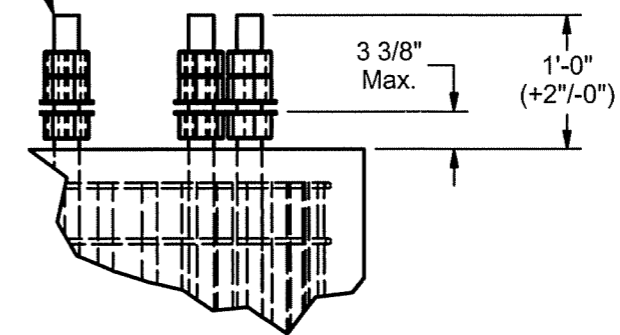

ANCHOR BOLT DETAIL

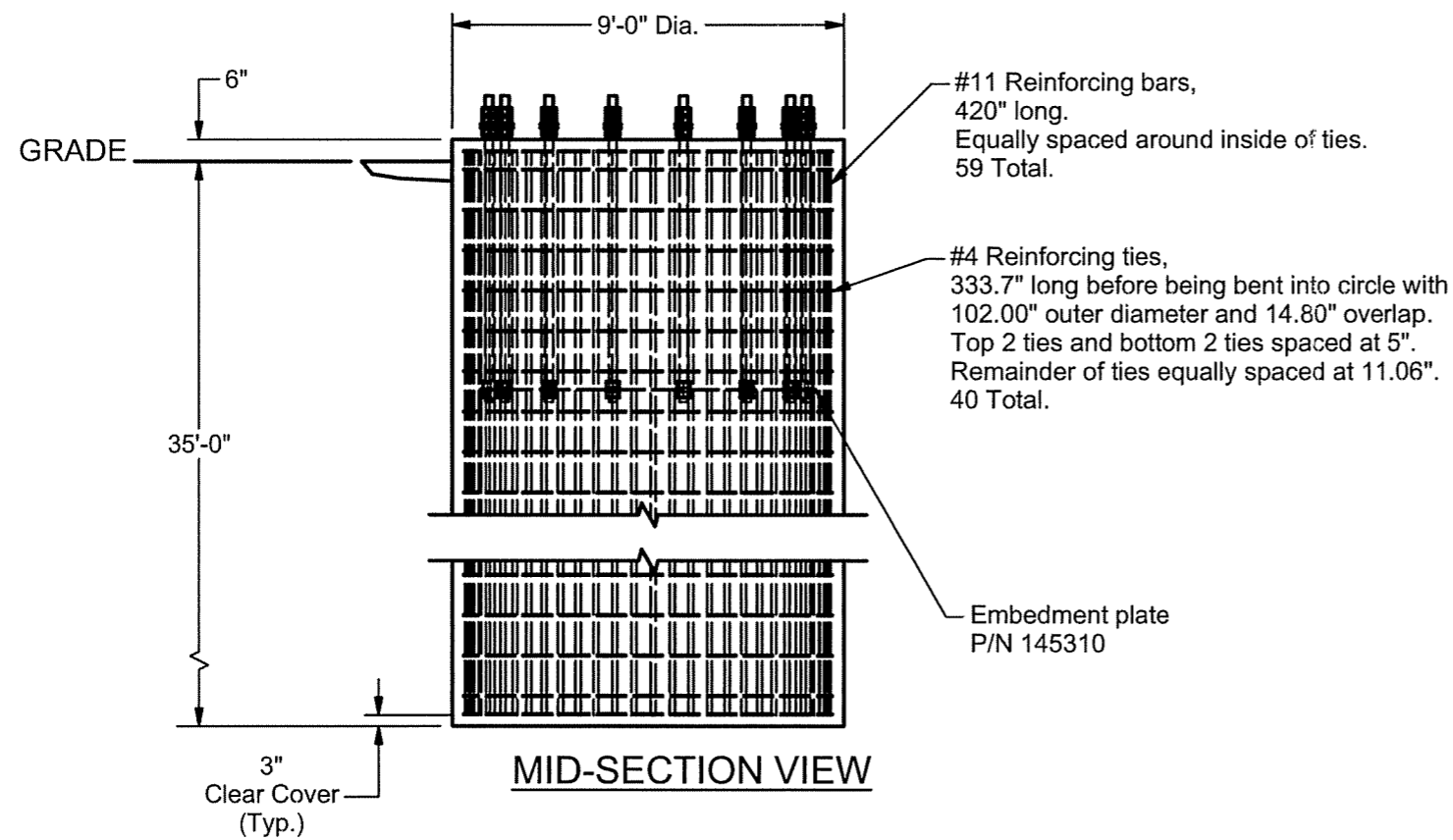

MID-SECTION VIEW

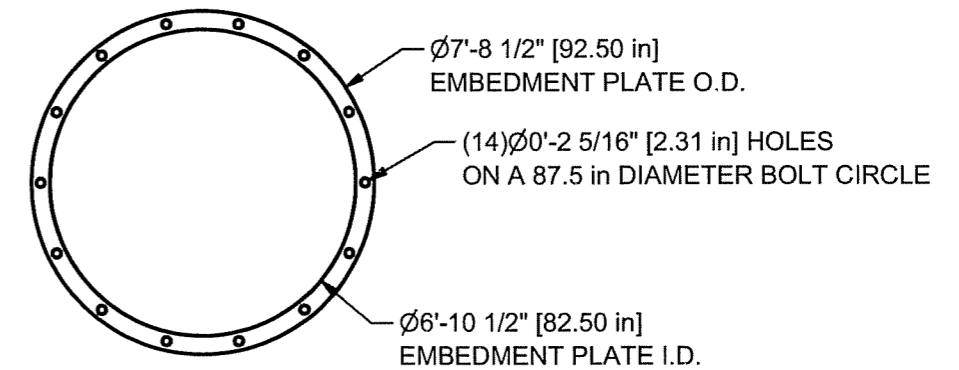

EMBEDMENT PLATE DETAIL

DRILLED PIER FOUNDATION
(CONCRETE VOLUME: 83.6 CU. YD. TOTAL)

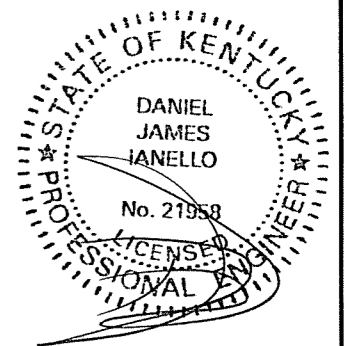

TITLE:
Nsoro MasTec, LLC
NTP 81" x 195'
Kevil/EV3166
Ballard Co., KY

NELLO CORPORATION
211 W. Washington St.,
Suite 2000
South Bend, IN 46601-1705
Bus: (574)288-3632
Fax: (574)288-5860

REV	BY	DATE	DESCRIPTION
1	DF	5/25/2011	Revised foundation reactions

COPYRIGHT NOTICE:
This drawing is the property of Nello Inc. It is not to be reproduced, copied or traced in whole or in part without our written consent.

ORIG. DATE: 4/19/2011
DWG. NO: 145308
DWG. PROG: v.2.1
SHEET: 1 OF 3

Tower Notes:

1. Tower is designed per TIA-222-G, "Structural Standard for Antenna Supporting Structures and Antennas," for the following loading conditions:
 90 mph 3-second gust basic wind speed with no ice
 30 mph 3-second gust basic wind speed with 1 inch basic ice thickness
 Structure Class: II
 Exposure Category: C
 Topographic Category: 1
2. Tower design loading is assumed to be based on site-specific data and must be verified by others prior to installation.
3. Tower design includes the antennas, dishes, and/or lines listed in the appurtenance loading tables on sheet 2.
4. Antenna mounting pipes may need to be field cut to match the lengths listed in the appurtenance loading tables on sheet 2.
5. Tower member design does not include stresses due to erection since erection equipment and procedures are unknown. Tower installation shall be performed by competent and qualified erectors in accordance with TIA-222-G and OSHA standards and all applicable building codes.
6. Field connections shall be bolted. No field welds shall be allowed unless otherwise noted.
7. Structural bolts shall conform to ASTM A325, except for 1/2 inch diameter and smaller bolts, which shall conform to ASTM A449 or SAE J429 Grade 5.
8. Structural steel and connection bolts shall be galvanized after fabrication in accordance with TIA-222-G.
9. All high strength bolts shall be tightened to a "snug tight" condition as defined in the November 13, 1985, AISC "Specification for Structural Joints Using ASTM A325 or A490 Bolts."
10. Tower shall be marked and lighted in conformance with local building codes, FAA regulations, and TIA-222-G.
11. Tower shall be grounded in conformance with local building codes and TIA-222-G.
12. Allowable tolerance on as-built tower steel height is plus 1% or minus 1/2%.
13. Maintenance and inspection shall be performed over the life of the structure in accordance with TIA-222-G.
14. Material specifications:
 NTP 18-Sided Pole - ASTM A572 Grade 65
 Pole Flange - ASTM A572 Grade 50
 Pole Porthole Rim - ASTM A572 Grade 65
15. A jacking nut is placed near the top of each section which will have another section placed on top. The distance from this top jacking nut to the bottom of the next section must not exceed the value given in the column labeled "Maximum Distance to Top Jacking Nut." Jacking may be required to achieve the proper overlap.
16. The horizontal distance between the vertical centerlines at any two elevations shall not exceed 0.25 percent of the vertical distance between the two elevations. Measure early in the morning before the sunward side of the pole expands.
17. Sections must be erected with the 0 degree azimuth lined up to ensure proper fit.
18. Remove anchor bolt template before erecting pole. Non-shrink grout may be placed under base flange after leveling pole. Drain holes must be provided if grouting.
19. Concrete contractor shall be responsible for properly aligning anchor bolts and materials before and after placing concrete, regardless of whether an anchor bolt template is provided.



TITLE:
 Nsoro MasTec, LLC
 NTP 81" X 195'
 Kevil / EV3166
 Ballard Co., KY

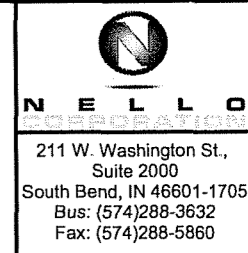

REV	BY	DATE	DESCRIPTION
1	MAM	5/20/2011	Revised tower loading per customer

COPYRIGHT NOTICE:
 This drawing is the property of Nello Inc. It is not to be reproduced, copied or traced in whole or in part without our written consent.

ORIG. DATE: 5/20/2011	DWG NO: 145307
DWG. PROG: v2.05	SHEET: 4 OF 4

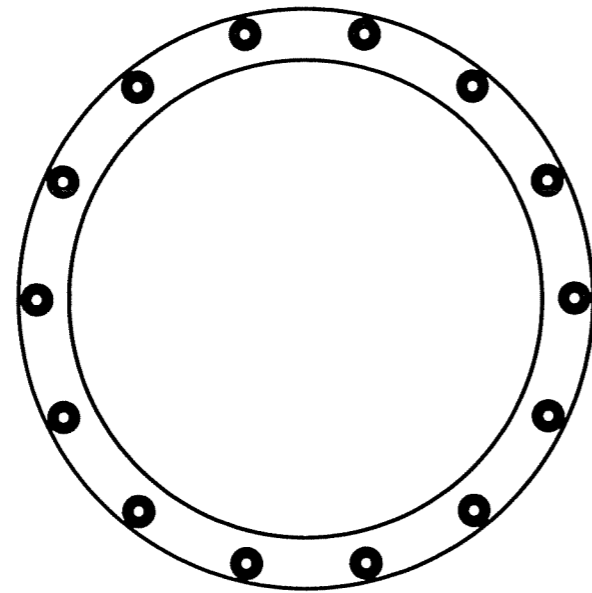

PLAN VIEW

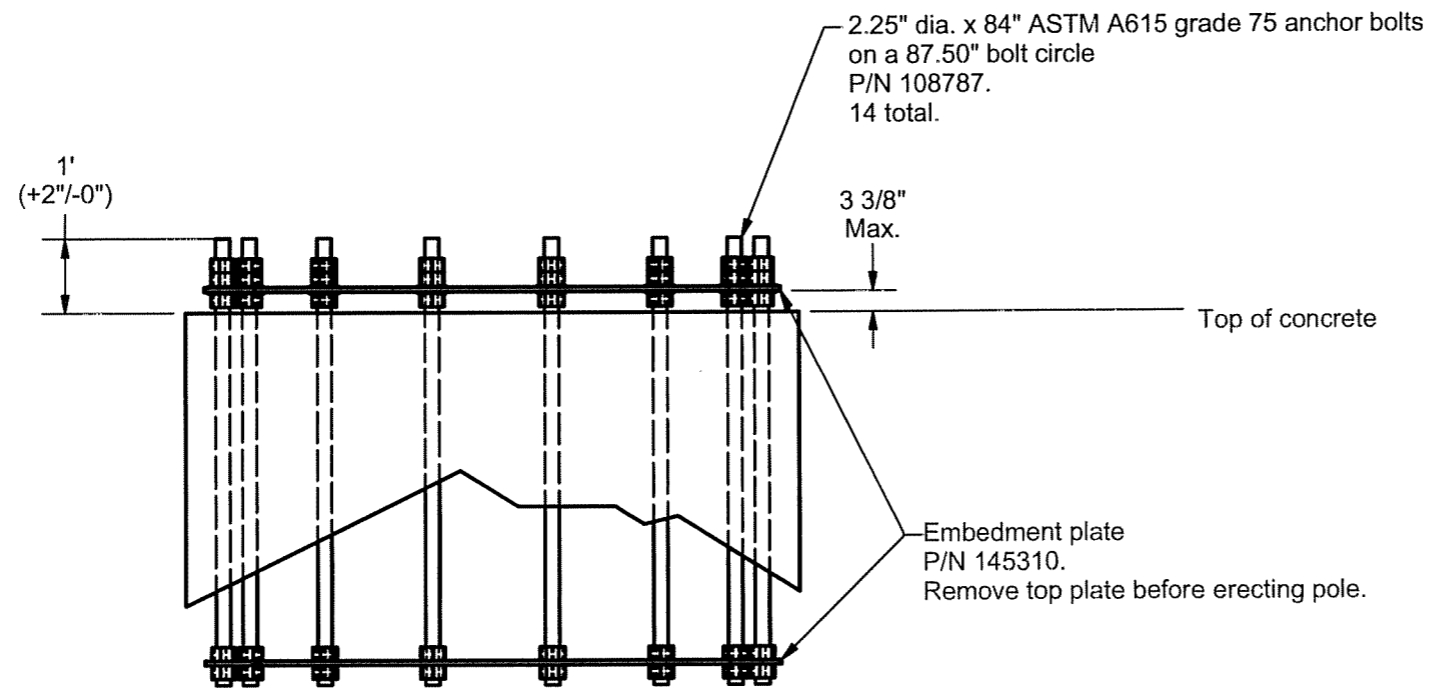

ANCHOR BOLT DETAIL

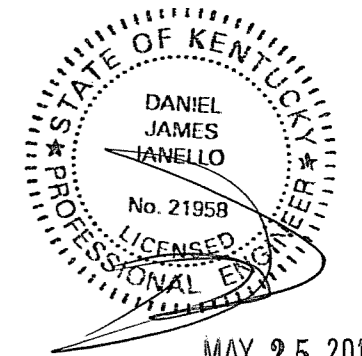

TITLE:
Nsoro MasTec, LLC
NTP 81" X 195'
Kevil / EV3166
Ballard Co., KY

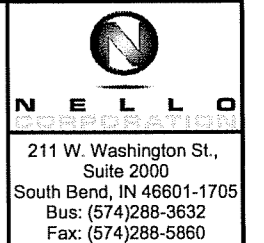

REV	BY	DATE	DESCRIPTION
1	MAM	5/20/2011	Revised tower loading per customer

COPYRIGHT NOTICE:
This drawing is the property of Nelco Inc. It is not to be reproduced, copied or traced in whole or in part without our written consent.

ORIG. DATE: 5/20/2011	DWG NO: 145307
DWG. PROG: v2.05	SHEET: 3 OF 4

Portholes

Elevation (ft)	Qty	Size (in)	Azimuth (deg)
189	3	8 x 16	60, 180, 300
171	3	8 x 16	60, 180, 300
159	3	8 x 16	60, 180, 300
144	3	8 x 16	60, 180, 300
7.5	1	10 x 30	0
7.5	1	10 x 30	90
7.5	1	10 x 30	180
7.5	1	10 x 30	270

Antenna Loading

Height	Qty.	Description
195'	1	4' Lightning Rod
195'	1	Beacon (12" x 36")
192'	12	Panel-96x12x3
192'	1	Low Profile Platform w/ Handrail
177'	12	Panel-96x12x3
177'	1	Low Profile Platform
162'	12	Panel-96x12x3
162'	1	Low Profile Platform
147'	12	Panel-96x12x3
147'	1	Low Profile Platform

Feedline Loading

Height	Qty.	Description
0' - 195'	2	1" Conduit
0' - 192'	24	LDF7-50A (1-5/8 FOAM)
0' - 177'	24	LDF7-50A (1-5/8 FOAM)
0' - 162'	24	LDF7-50A (1-5/8 FOAM)
0' - 147'	24	LDF7-50A (1-5/8 FOAM)

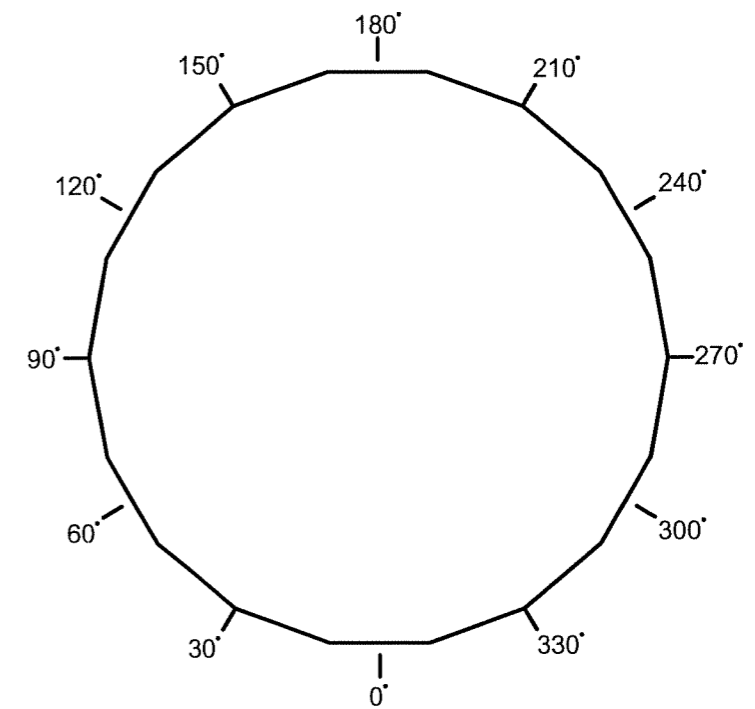

Step Bolts on This Side of Pole

Note:
The azimuths referenced here are only to illustrate where the pole features are in relation to each other. The azimuths are not to indicate which cardinal direction the anchor bolts or the pole should be positioned.

Pole Reference Azimuths

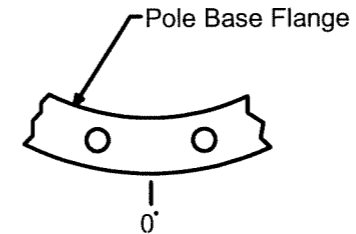

Anchor Bolt Holes Are on Either Side of the 0 Degree Azimuth

Anchor Bolt Azimuth

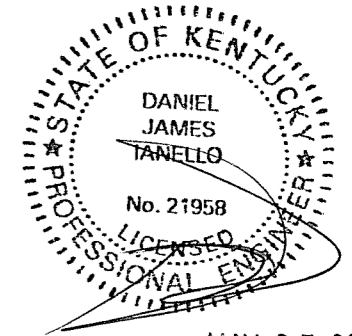

MAY 25 2011

TITLE:
Nsoro MasTec, LLC
NTP 81" X 195'
Kevil / EV3166
Ballard Co., KY

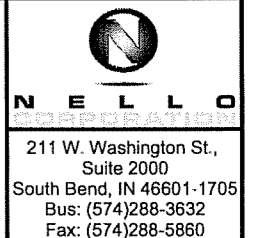

REV	BY	DATE	DESCRIPTION
1	MAM	5/20/2011	Revised tower loading per customer

COPYRIGHT NOTICE:
This drawing is the property of Nello Inc. It is not to be reproduced, copied or traced in whole or in part without our written consent.

ORIG. DATE: 5/20/2011	DWG NO: 145307
DWG. PROG: v2.05	SHEET: 2 OF 4

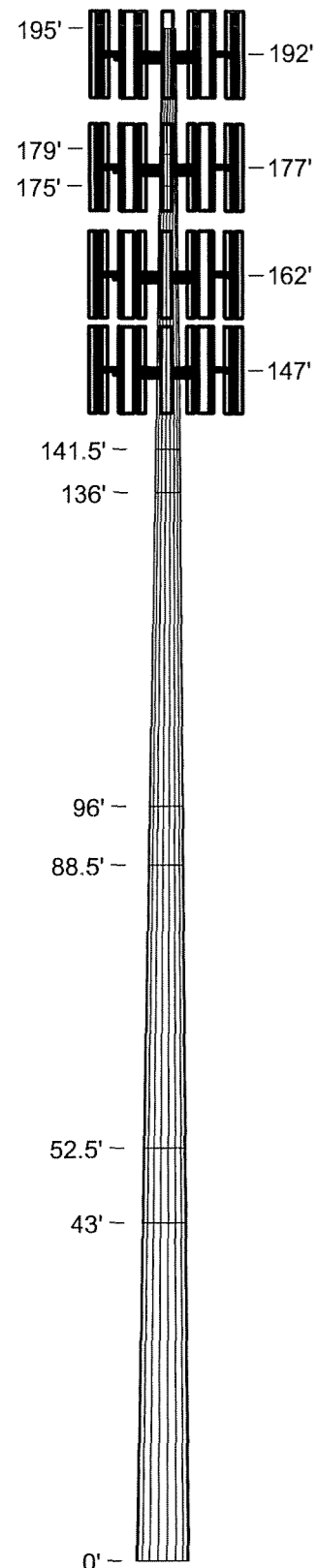

Pole Section Data

Section	Bottom Height (ft)	Top Height (ft)	Length (ft)	Number of Sides	Bottom OD (in)	Top OD (in)	Wall Thickness (in)	Material	Approximate Weight (lb)	Design Overlap (in)	Minimum Overlap (in)	Maximum Overlap (in)	Design Distance to Top Jacking Nut (in)	Maximum Distance to Top Jacking Nut (in)	Minimum Distance to Top Jacking Nut (in)
1	175	195	20	18	28.2969	22.0000	0.1875	A572-65	1130	48	41 3/4	50 1/8	15	21 1/4	12 7/8
2	136	179	43	18	40.0134	26.4750	0.2500	A572-65	4180	66	59 3/16	71	15	21 13/16	10
3	88.5	141.5	53	18	54.2811	37.5943	0.2500	A572-65	7130	90	80 5/8	96 3/4	15	24 3/8	8 1/4
4	43	96	53	18	67.9191	51.2323	0.3125	A572-65	11560	114	100 15/16	121 1/8	15	28 1/16	7 7/8
5	0	52.5	52.5	18	80.6450	64.1156	0.3750	A572-65	18070						

Tower Reactions

No Ice
 Shear: 41.5 kips
 Moment: 5440.1 ft-kips
 Weight: 70.2 kips

With Ice
 Shear: 5.5 kips
 Moment: 752.3 ft-kips
 Weight: 123.1 kips

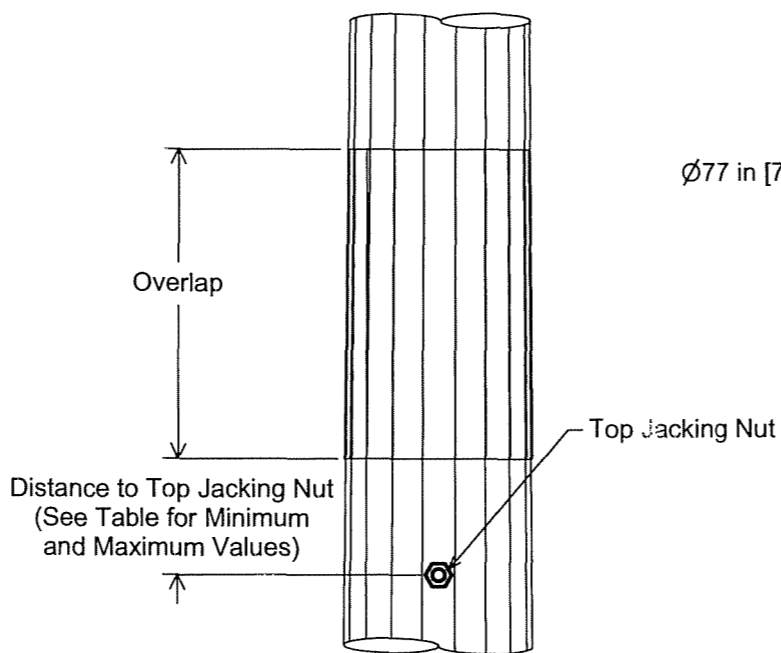

A jacking nut is placed near the top of each section which will have another section placed on top. The distance from this nut to the bottom of the next section must not exceed the value given in the column labeled "Maximum Distance to Top Jacking Nut."

Pole Splice Detail

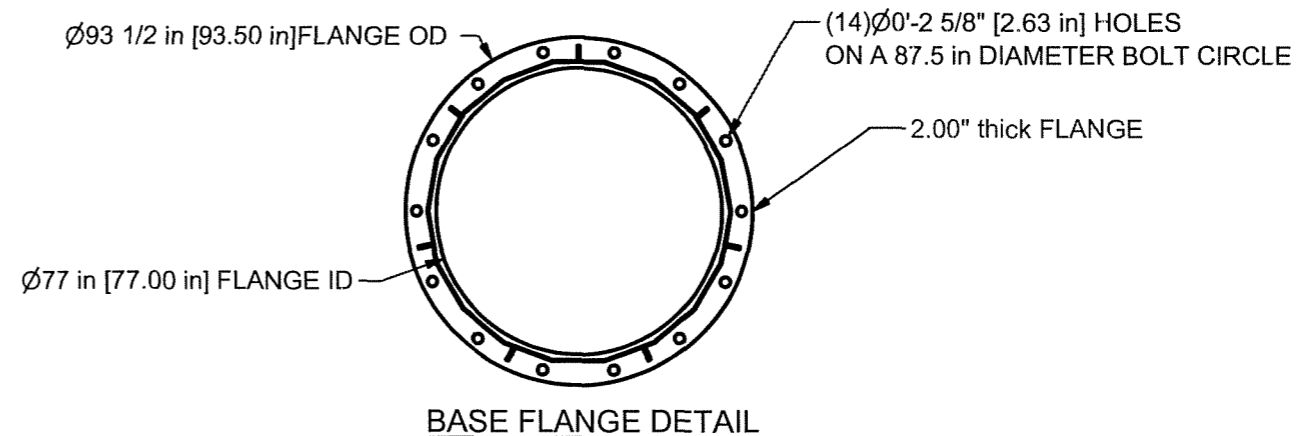

BASE FLANGE DETAIL

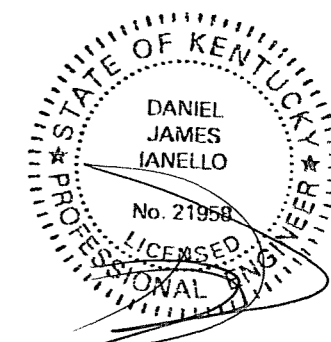

MAY 25 2011

TITLE:
 Nsoro MasTec, LLC
 NTP 81" X 195'
 Kevil / EV3166
 Ballard Co., KY

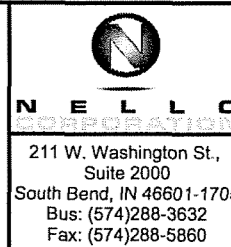

REV	BY	DATE	DESCRIPTION
1	MAM	5/20/2011	Revised tower loading per customer

COPYRIGHT NOTICE:
 This drawing is the property of Nello Inc. It is not to be reproduced, copied or traced in whole or in part without our written consent.

ORIG. DATE: 5/20/2011	DWG NO: 145307
DWG. PROG: v2.05	SHEET: 1 OF 4

Exhibit E

Geotechnical Investigation

AT&T Site EV3166 (Kevil)
174 Liberty Church Road.
Kevil, Ballard County, Kentucky

March 15, 2011

Submitted to:

AT&T Mobility
10830 Penion Drive
Louisville, Kentucky 40299

by:

*Environmental Corporation of America
1375 Union Hill Industrial Ct. Ste A
Alpharetta, Georgia 30004
ECA Project No. M-383-4*



ENVIRONMENTAL CORPORATION OF AMERICA

March 15, 2011

AT&T Mobility
10830 Penion Drive
Louisville, Kentucky 40299

Attention: Ms. Michelle Ward

Subject: **Report of Geotechnical Investigation
AT&T Site EV3166 (Kevil)
174 New Liberty Church Road
ECA Project No. M-383-4**

Dear Ms. Ward:

Environmental Corporation of America (ECA) is pleased to submit this report of our investigation for the proposed project. Our services were provided as authorized on March 1, 2011.

This report presents a review of the information provided to us, a description of the site and subsurface conditions, and our recommendations. The appendices contain a Boring Location Plan and Boring Log.

Purpose and Scope of Work

The purpose of this exploration was to obtain specific subsurface data at the site and to provide geotechnical-related design parameters and construction recommendations for the proposed tower.

Our scope of work included the following:

- One soil test boring was drilled to a depth of 40 feet below the ground surface (bgs). Figure 1 shows the approximate boring location. Standard penetration tests (SPTs) were conducted to obtain soil samples and SPT (N) values, in accordance with ASTM D1586.
- The depth to groundwater, if any, was measured in the boring after drilling was completed.

- The soil samples were visually classified and a boring log was prepared. The soil conditions were evaluated by a registered professional engineer and this geotechnical report was prepared with our recommendations.

No physical testing of soil samples has been conducted to calculate site specific bearing capacities or settlements. We have recommended design parameters and settlements based on the SPT (N) values, an examination of the soil samples, and our experience with similar soil conditions and structures.

Project Information

We were provided with an Site Data Package with coordinates of the tower center. No survey was provided, however, the site was staked. The Property is in a grassed field.

We understand that plans call for the construction of a 195 foot monopole tower on the site. We assume that the equipment building/cabinets will be pre-fabricated structures supported on a perimeter grade beam or spread footing.

Site Conditions

The fieldwork was conducted on March 7, 2011. Information obtained from the boring was used to help us evaluate the subsurface conditions and to assist in formulating our recommendations.

Subsurface Conditions

The subsurface conditions were explored with one soil test boring, B-1, drilled approximately as shown on Figure 1. The site had been staked prior to our visit.

Soils encountered in the boring graded from clayey silt, to clayey sand with chert gravel, to silty sand and cobbles. The gravel in the deeper soils was semi-rounded. The soils classified as ML, SC, SM, GM, and GP soil types based on the Unified Soil Classification System (USCS). N-values ranged from 9 to over 100 blows per foot (bpf).

Groundwater was not present in the boring at the time drilling was completed.

Recommendations

Tower Foundations: The subsurface conditions are suitable for support of the tower using a mat or caisson foundation.

For a mat foundation, we recommend that the mat be supported at a depth of 5 feet minimum and be designed for a maximum net allowable soil bearing pressure of 4 kips per square foot (ksf). Total and differential settlements should be less than about 1-inch and ½-inch, respectively.

For caisson foundation design, we recommend a friction design with the depth of the caisson dependent on the capacity required. Soil parameters that may be of use in design are as follows:

	Depth below surface			
	0-12 ft	12-22 ft	22-32 ft	32-40 ft
Coefficient of passive earth pressure	1.2	3.7	4.6	5.5
Unit weight of soil (pcf)	105	115	120	125
Lateral subgrade modulus (pci)	100	200	300	400
Cohesion, psf	1000	500	0	0
Angle of internal friction, degrees	5	35	40	44
Allowable skin friction (ksf)	0.18	0.6	1.0	1.4
Allowable end bearing (ksf)	*	5	8	10

* Terminating a caisson at these depths is not suggested

Groundwater should not be encountered in caisson borings. However, the contractor should be prepared to remove softened soils and seepage before concrete placement.

Building Foundations: The proposed equipment cabinet(s) can be supported on a spread footing foundation. A maximum allowable net bearing pressure of 2.0 kips per ft² should be used to design the building/cabinet foundation. Total and differential settlements should be less than 1/2-inch and 1/4-inch, respectively.

Foundation Excavations: To avoid softening of the shallow soils exposed at the foundation bearing level, excavations should not be left open for extended periods, prior to placing reinforcing steel and concrete. If rain or freezing weather is expected, excavations should not be completed. Leaving the excavations at least 1 ft above final grade should protect the bearing soils from deterioration.

If the excavation must remain open overnight or if rainfall becomes imminent while the bearing soils are exposed, we recommend that a 2 to 4-inch thick "mud-mat" of "lean" (2000 psi) concrete be placed on the bearing soils before the placement of reinforcing steel. If the bearing soils are softened by surface water intrusion or exposure, the softened soils must be removed from the foundation excavation bottom immediately prior to placement of concrete.

Fill Placement: The amount of fill required for this project depends on the planned final grades, but we expect it to be minimal. Any required fill should be placed in maximum 8-inch thick lifts. The soil moisture content should be close to the optimum moisture content. The soil should be compacted to at least 98% of the maximum dry density, as determined by the standard Proctor method (ASTM D-698).

In areas supporting floor slabs or pavements, the upper 18 inches of fill should be compacted to 100% of the standard Proctor density. As no laboratory testing has been conducted, we do not know the capability of the surficial soil to support pavements. However, we suggest that the upper soils be replaced by granular fill in areas of heavy traffic to improve the subgrade support capabilities and moisture sensitivity.

Field density tests should be conducted at routine intervals, as the fill is being placed, to verify that adequate compaction is achieved.

Prior to placing any new fill, any soft or loose near surface soils should be removed and the area proofrolled with a heavy vehicle to confirm that any unsuitable soil conditions have been discovered.

Basis for Recommendations

The subsurface conditions encountered at the boring location are shown on the Boring Log in Appendix B. This Boring Log represents our interpretation of the subsurface conditions based on the field logs and visual examination of field samples by an engineer. The lines designating the interface between various strata on the Boring Log represent the approximate interface locations. In addition, the transition between strata may be gradual. The water level shown on the Boring Log, if any, represents the condition only at the time of our exploration.

The recommendations contained herein are based in part on project information provided to us and only apply to the specific project and site discussed in this report. If the project information section in this report contains incorrect information or if additional information is available, please let us know so that we may review the validity of our recommendations.

Regardless of the thoroughness of a geotechnical investigation, there is always a possibility that conditions between borings will be different from those at specific boring locations and that conditions will not be as anticipated by the designers or contractors. In addition, the construction process may itself alter soil conditions. Therefore, experienced geotechnical personnel should observe and document the construction procedures used and the conditions encountered. Unanticipated conditions and inadequate procedures should be reported to the design team along with timely recommendations to solve the problems created. ECA is best qualified to provide this service based on our familiarity with the project, the subsurface conditions, and the intent of the recommendations and design.

We wish to remind you that we will store the soil samples for 30 days. The samples will then be discarded unless you request otherwise.

Ms. Michelle Ward
Page 5

We will be happy to discuss our recommendations with you and look forward to providing the additional studies or services necessary to complete this project. We appreciate the opportunity to be of service. Please call us with any questions at (770) 667-2040.

Sincerely,
Environmental Corporation of America

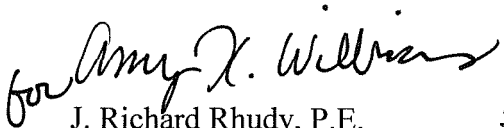

J. Richard Rhudy, P.E.
Principal Engineer
KY Reg. # 27450

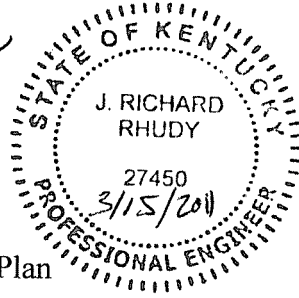

Kelby Williams
Project Manager

Appendix A Boring Location Plan
Appendix B Boring Log

APPENDIX A

FIGURE

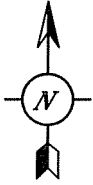

Residential

▲
B-1

Grassed

Agricultural

Commercial Buildings

Kentucky Ave.

NOT TO SCALE

LEGEND



SOIL BORING

GEOTECHNICAL INVESTIGATION
AT&T EV3166 KEVIL, Kevil, KY
FIGURE 1: BORING LOCATION PLAN

SOURCE: Google Earth Aerial

BY: JRR REV. BY:
FILE NAME:

CREATION DATE: 3/15/11
REV. DATE:



ECA Project # M-383-4

APPENDIX B
BORING LOG

Project: AT&T Site EV3166 (Kevil)

Log of Boring: B-1

City, State Kevil, Kentucky

Client: Nsoro Mas Tec, LLC

Drill Date: March 7, 2011

ECA Job No: M-383-4

Field Rep: Fred

Elevation (ft)	Depth	SUBSURFACE PROFILE		SAMPLE			Water depth		
		Symbol	Description	Blow Counts (per ft)	SPT Values (blows/ft)			Remarks	
					10	20	30	40	
0	0		Ground Surface						
	5		Stiff to very stiff brown clayey SILT (ML)	9					
				16					
				14					
				12					
-12	15		Very dense brown very silty clayey SAND w/ chert gravel (SC)	59					
	20			100+					
-22	25		Very dense tan slightly silty fine to coarse SAND and gravel (SM/GM)	100+					
	30			100+					
	35			100+					
-32	40		Very dense tan medium to coarse GRAVEL (GP)	100+					
-40				100+					

Drilled By: Tri-State Drilling

Depth to Water: N/A

Borehole Size: 2.25" ID

Total Depth: 40 ft

Drill Method: Hollow Stem Augers

Sheet: 1 of 1

Environmental Corp. of America
 1375 Union Hill Indus. Ct., Ste A
 Alpharetta, GA 30004
 (770) 667-2040



Exhibit F

Competing Utilities, Corporations or Persons

American Towers

Crown Communication

SBA Towers

Verizon

Sprint / Nextel

T-Mobile

Shared Sites

Cricket

Pegasus Towers

Mobilitie

Tower Access Group, LLC

Kevil Grid Map

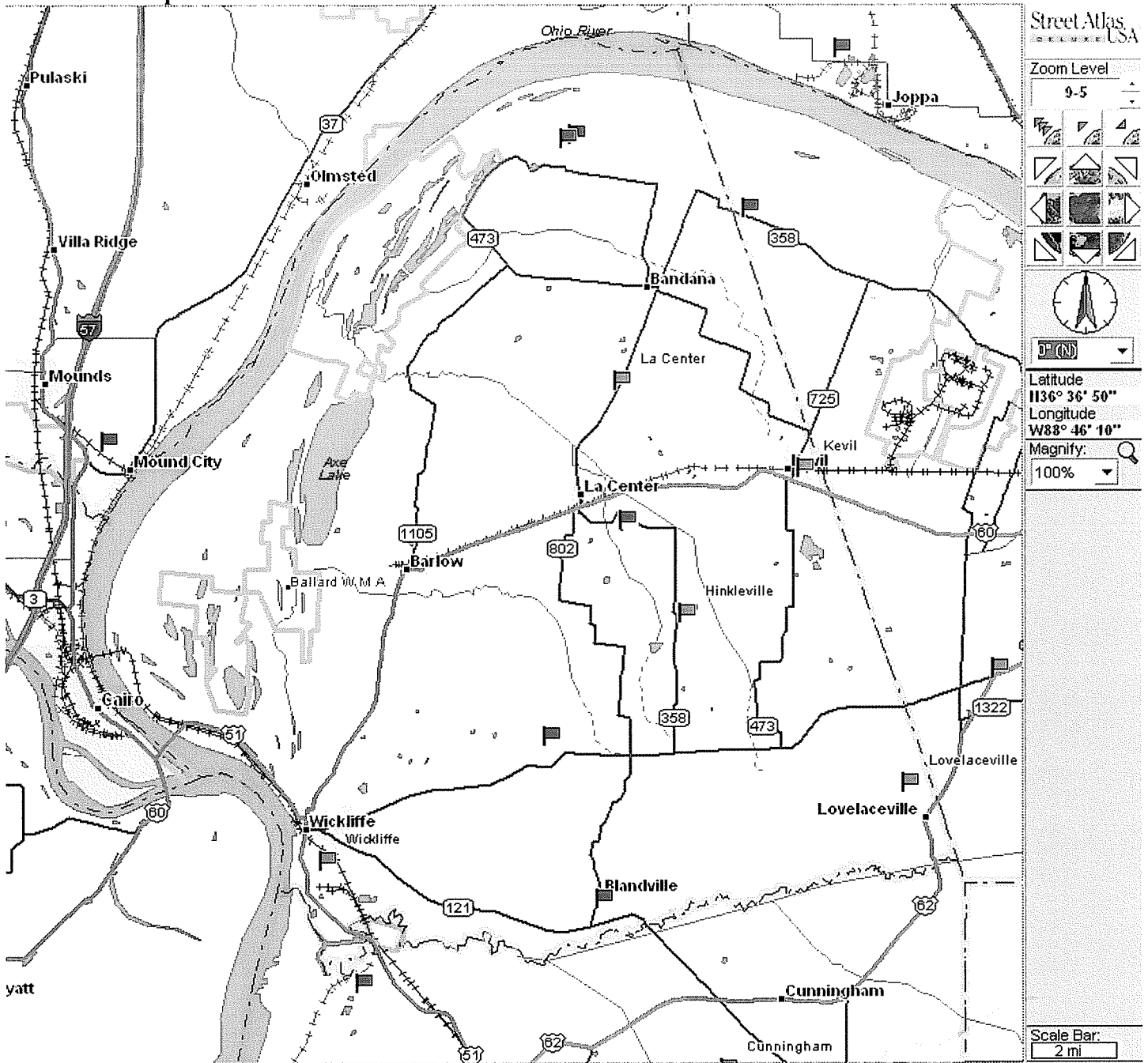

Red Flags indicate AT&T existing and proposed locations.
Blue Flags indicate non-AT&T existing towers.

Exhibit G



Federal Aviation Administration

<< OE/AAA

Notice Criteria Tool

The requirements for filing with the Federal Aviation Administration for proposed structures vary based on a number of factors: height, proximity to an airport, location, and frequencies emitted from the structure, etc. For more details, please reference CFR Title 14 Part 77.9.

You must file with the FAA at least 45 days prior to construction if:

- * your structure will exceed 200ft above ground level
- * your structure will be in proximity to an airport and will exceed the slope ratio
- * your structure involves construction of a traverseway (i.e. highway, railroad, waterway etc...)
- * your structure will emit frequencies, and does not meet the conditions of the FAA Co-location Policy
- * your structure will be in an instrument approach area and might exceed part 77 Subpart C
- * your structure will be on an airport or heliport

If you require additional information regarding the filing requirements for your structure, please identify and contact the appropriate FAA representative using the Air Traffic Areas of Responsibility map for Off Airport construction, or contact the FAA Airports Region / District Office for On Airport construction.

The tool below will assist in applying Part 77 Notice Criteria.

Latitude:	<input type="text" value="37"/> Deg	<input type="text" value="4"/> M	<input type="text" value="55.85"/> S	<input type="text" value="N"/>
Longitude:	<input type="text" value="88"/> Deg	<input type="text" value="52"/> M	<input type="text" value="56.94"/> S	<input type="text" value="W"/>
Horizontal Datum:	<input type="text" value="NAD83"/>			
Site Elevation (SE):	<input type="text" value="429"/> (nearest foot)			
Structure Height (AGL):	<input type="text" value="199"/> (nearest foot)			
Traverseway:	<input type="text" value="No Traverseway"/>			
(Additional height is added to certain structures under 77.9(c))				
Is structure on airport:	<input checked="" type="radio"/> No <input type="radio"/> Yes			

Results

You do not exceed Notice Criteria.

From: Houlihan, John (KYTC) [mailto:John.Houlihan@ky.gov]
Sent: Tuesday, May 31, 2011 10:38 AM
To: Richard S. Elms
Subject: RE: Study number AS-004-PAH-2011-021 (AT&T site Kevil)
Importance: Low

Mr. Elms,

The above subject does not require a permit from the Kentucky Airport Zoning Commission, due to the height being reduced to 199 feet AGL. The 199 foot antenna does not exceed any of the following criteria:

602 KAR 50:030. Jurisdiction of the Kentucky Airport Zoning Commission.

RELATES TO: KRS 183.861, 183.865, 183.867, 183.870

STATUTORY AUTHORITY: KRS 183.861

NECESSITY, FUNCTION, AND CONFORMITY: KRS 183.867 specifies that the commission has jurisdiction over zoning for all public use and military airports. This administrative regulation defines the areas over which the Kentucky Airport Zoning Commission has jurisdiction for the purpose of zoning in accordance with KRS Chapter 183 and specifics when the owner or person who has control over a structure which encroaches on the jurisdiction of the Kentucky Airport Zoning Commission shall apply for a permit.

Section 1. The commission has zoning jurisdiction over that airspace over and around the public use and military airports within the Commonwealth which lies above the imaginary surface that extends outward and upward at one (1) of the following slopes:

(1) 100 to one (1) for a horizontal distance of 20,000 feet from the nearest point of the nearest runway of each public use and military airport with at least one (1) runway 3,200 feet or more in length; or

(2) Fifty (50) to one (1) for a horizontal distance of 10,000 feet from the nearest point of the nearest runway of each public use and military airport with its longest runway less than 3,200 feet in actual length.

Section 2. The commission has zoning jurisdiction over the use of land and structures within public use airports within the state.

Section 3. The commission has jurisdiction from the ground upward within the limits of the primary and approach surfaces of each public use and military airport as depicted on Airport Zoning Maps approved by the Kentucky Airport Zoning Commission.

Section 4. The commission has jurisdiction over the airspace of the Commonwealth that exceeds 200 feet in height above ground level.

Section 5. The owner or person who has control over a structure which penetrates or will penetrate the airspace over which the commission has jurisdiction shall apply for a permit from the commission in accordance with 602 KAR 50:090. (KAV-9-1; 1 Ky.R. 807; eff. 5-14-75; Am. 2 Ky.R. 306; eff. 3-10-76; 5 Ky.R. 599; eff. 3-7-79; 10 Ky.R. 445; eff. 1-4-84; 14 Ky.R. 267; eff. 9-10-87; 19 Ky.R. 800; eff. 11-4-92; 27 Ky.R. 2228; 2774; eff. 4-9-2001.)

Please see the above attachment you requested.

Please keep this email for your records.

Thank you.

Kentucky Airport Zoning Commission
John Houlihan, Administrator
90 Airport Road, Building 400
Frankfort, KY 40601
Desk 502.564.0310
Cell 502.330.3955

<http://transportation.ky.gov/aviation/kyzoning.html>

CONFIDENTIALITY NOTICE: This e-mail message, including any attachments, is for the sole use of the intended recipient(s) and may contain confidential and privileged information. Any unauthorized review, use, disclosure or distribution is prohibited. If you are not the intended recipient, please contact the sender by reply e-mail or call (502) 564-0310 and destroy all copies of the original message.

Exhibit H

ULS License

Cellular License - KNKN830 - NEW CINGULAR WIRELESS PCS, LLC

Call Sign	KNKN830	Radio Service	CL - Cellular
Status	Active	Auth Type	Regular

Market

Market	CMA443 - Kentucky 1 - Fulton	Channel Block	A
Submarket	0	Phase	2

Dates

Grant	08/21/2001	Expiration	10/01/2011
Effective	11/15/2010	Cancellation	

Five Year Buildout Date

02/11/1997

Control Points

1 1650 Lyndon Farms Court, LOUISVILLE, KY
P: (502)332-4700

Licensee

FRN	0003291192	Type	Limited Liability Company
-----	------------	------	---------------------------

Licensee

NEW CINGULAR WIRELESS PCS, LLC 5601 LEGACY DRIVE, MS: A-3 PLANO, TX 75024 ATTN FCC GROUP	P:(469)229-7471 F:(469)229-7297 E:LG5201@ATT.COM
---	--

Contact

AT&T MOBILITY LLC Michael Goggin 1120 20th Street, NW, Suite 1000 Washington, DC 20036 ATTN Michael P. Goggin	P:(202)457-2055 F:(202)457-3073 E:MG7268@att.com
---	--

Ownership and Qualifications

Radio Service Type Mobile
Regulatory Status Common Carrier Interconnected Yes

Alien Ownership

The Applicant answered "No" to each of the Alien Ownership questions.

Basic Qualifications

The Applicant answered "No" to each of the Basic Qualification questions.

Demographics

Exhibit I

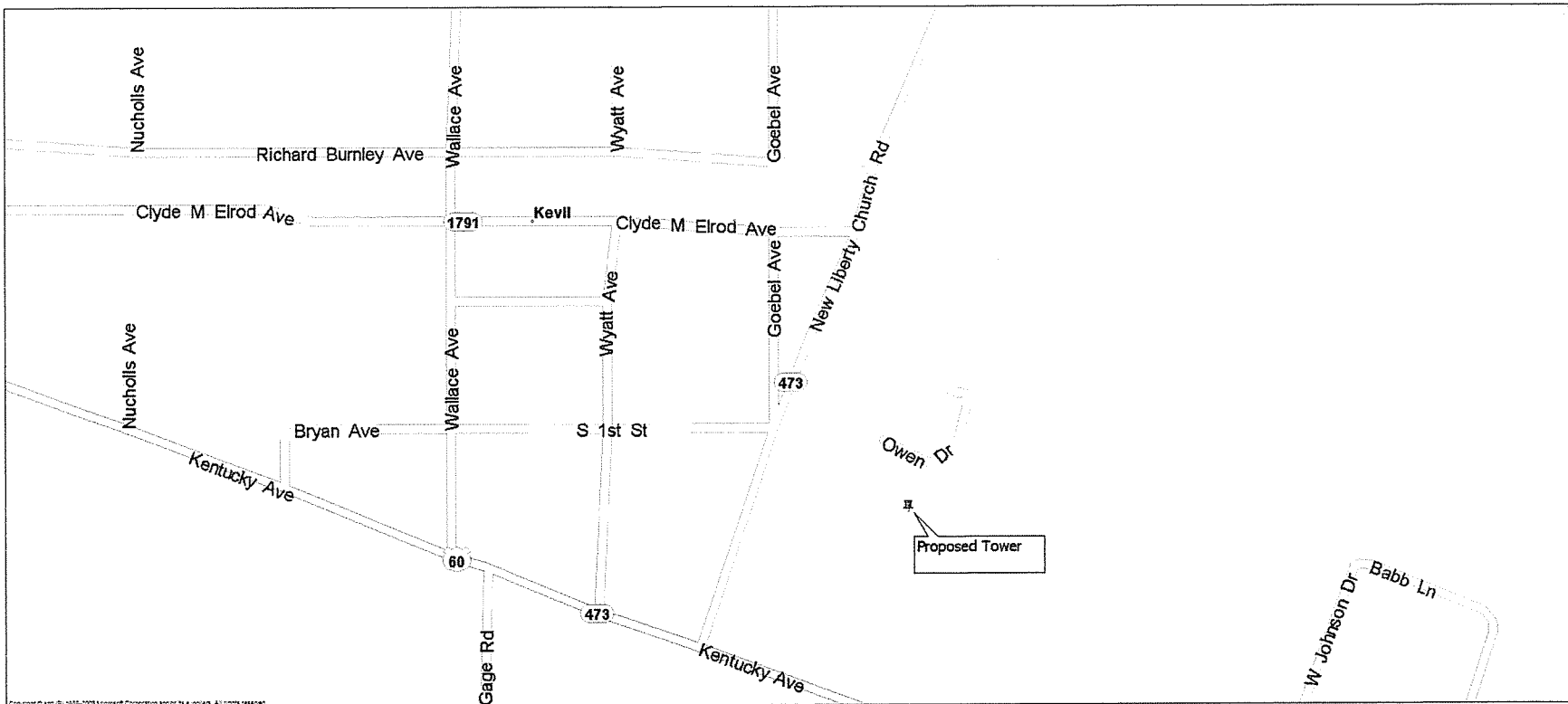

Directions to Site: From Wickliffe at the intersection of U.S. 60/U.S. 51 (4th Street) and State Route 121 (Court Street), proceed North on U.S. 60/U.S. 51 approximately .03 miles and bear right onto U.S. 60 (4th Street). Proceed on U.S. 60 for approximately 16.0 miles to the intersection of State Route 473 (New Liberty Church Road). Turn left onto New Liberty Church Road and proceed approximately .10 miles to access road on right. Proposed site is at the end of the access road.

Prepared by: Briggs Law Office, PSC (502) 412-9222

Market: Louisville
Cell Site Number: EV3166
Cell Site Name: Kevil
Fixed Asset Number: 10146920

OPTION AND LEASE AGREEMENT

THIS OPTION AND LEASE AGREEMENT ("**Agreement**"), dated as of the latter of the signature dates below (the "**Effective Date**"), is entered into by Paul Richard Owen, an individual, having a mailing address of 668 Veterans Avenue Kevil, Kentucky 42053 ("**Landlord**") and New Cingular Wireless PCS, LLC, a Delaware limited liability company, having a mailing address of 12555 Cingular Way, Suite 1300, Alpharetta, GA 30004 ("**Tenant**").

BACKGROUND

Landlord owns or controls that certain plot, parcel or tract of land, together with all rights and privileges arising in connection therewith, located at 174 New Liberty Church Rd, in the County of Ballard, State of Kentucky (collectively, the "**Property**"). Tenant desires to use a portion of the Property in connection with its federally licensed communications business. Landlord desires to grant to Tenant the right to use a portion of the Property in accordance with this Agreement.

The parties agree as follows:

1. OPTION TO LEASE.

(a) Landlord grants to Tenant an option (the "**Option**") to lease a certain portion of the Property containing approximately 10,000 square feet including the air space above such ground space for the placement of Tenant's Communication Facility as described on attached **Exhibit 1**(the "**Premises**").

(b) During the Option Term (as defined below) , and during the term of this Agreement, Tenant and its agents, engineers, surveyors and other representatives will have the right to enter upon the Property to inspect, examine, conduct soil borings, drainage testing, material sampling, radio frequency testing and other geological or engineering tests or studies of the Property (collectively, the "**Tests**"), to apply for and obtain licenses, permits, approvals, or other relief required of or deemed necessary or appropriate at Tenant's sole discretion for its use of the Premises and include, without limitation, applications for zoning variances, zoning ordinances, amendments, special use permits, and construction permits (collectively, the "**Government Approvals**"), initiate the ordering and/or scheduling of necessary utilities, and otherwise to do those things on or off the Property that, in the opinion of Tenant, are necessary in Tenant's sole discretion to determine the physical condition of the Property, the environmental history of the Property, Landlord's title to the Property and the feasibility or suitability of the Property for Tenant's Permitted Use, all at Tenant's expense. Tenant will not be liable to Landlord or any third party on account of any pre-existing defect or condition on or with respect to the Property, whether or not such defect or condition is disclosed by Tenant's inspection. Tenant will restore the Property to its condition as it existed at the commencement of the Option Term, reasonable wear and tear and casualty not caused by Tenant excepted. In addition, Tenant shall indemnify, defend and hold Landlord harmless from and against any and all injury, loss, damage or claims arising directly out of Tenant's Tests.

(c) In consideration of Landlord granting Tenant the Option, Tenant agrees to pay Landlord the sum of [REDACTED] within thirty (30) business days of the Effective Date. The Option will be for an initial term of six (6) months commencing on the Effective Date (the "**Initial Option Term**") and may be renewed by Tenant for an additional six (6) month period (the "**Renewal Option Term**") upon written notification to Landlord and the payment of an additional [REDACTED] no later than ten (10) days prior to the expiration date of the Initial Option Term. The Initial Option Term and any Renewal Option Term are collectively referred to as the "**Option Term.**"

(d) The Option may be sold, assigned or transferred at any time by Tenant to an Affiliate of Tenant or to any third party agreeing to be subject to the terms hereof. Otherwise, the Option may not be sold, assigned

or transferred without the written consent of Landlord, such consent not to be unreasonably withheld, conditioned or delayed. From and after the date the Option has been sold, assigned or transferred by Tenant to a third party agreeing to be subject to the terms hereof, Tenant shall immediately be released from any and all liability under this Agreement, including the payment of any rental or other sums due, without any further action.

(e) During the Option Term, Tenant may exercise the Option by notifying Landlord in writing. If Tenant exercises the Option then Landlord leases the Premises to Tenant subject to the terms and conditions of this Agreement. If Tenant does not exercise the Option during the Initial Option Term or any extension thereof, this Agreement will terminate and the parties will have no further liability to each other.

(f) If during the Option Term, or during the term of this Agreement if the Option is exercised, Landlord decides to subdivide, sell, or change the status of the zoning of the Premises, Property or any of Landlord's contiguous, adjoining or surrounding property (the "**Surrounding Property**,") or in the event of foreclosure, Landlord shall immediately notify Tenant in writing. Any sale of the Property shall be subject to Tenant's rights under this Agreement. Landlord agrees that during the Option Term, or during the Term of this Agreement if the Option is exercised, Landlord shall not initiate or consent to any change in the zoning of the Premises, Property or Surrounding Property or impose or consent to any other restriction that would prevent or limit Tenant from using the Premises for the Permitted Use.

2. PERMITTED USE. Tenant may use the Premises for the transmission and reception of communications signals and the installation, construction, maintenance, operation, repair, replacement and upgrade of its communications fixtures and related equipment, cables, accessories and improvements, which may include a suitable support structure, associated antennas, equipment shelters or cabinets and fencing and any other items necessary to the successful and secure use of the Premises (collectively, the "**Communication Facility**"), as well as the right to test, survey and review title on the Property; Tenant further has the right but not the obligation to add, modify and/or replace equipment in order to be in compliance with any current or future federal, state or local mandated application, including, but not limited to, emergency 911 communication services, at no additional cost to Tenant or Landlord (collectively, the "**Permitted Use**"). Landlord and Tenant agree that any portion of the Communication Facility that may be conceptually described on **Exhibit 1** will not be deemed to limit Tenant's Permitted Use. If **Exhibit 1** includes drawings of the initial installation of the Communication Facility, Landlord's execution of this Agreement will signify Landlord's approval of **Exhibit 1**. For a period of ninety (90) days following the start of construction, Landlord grants Tenant, its subtenants, licensees and sublicensees, the right to use such portions of Landlord's contiguous, adjoining or Surrounding Property as described on **Exhibit 1** as may reasonably be required during construction and installation of the Communications Facility. Tenant has the right to install and operate transmission cables from the equipment shelter or cabinet to the antennas, electric lines from the main feed to the equipment shelter or cabinet and communication lines from the Property's main entry point to the equipment shelter or cabinet, and to make Property improvements, alterations, upgrades or additions appropriate for Tenant's use ("**Tenant Changes**"). Tenant Changes include the right to construct a fence around the Premises and undertake any other appropriate means to secure the Premises at Tenant's expense. Tenant agrees to comply with all applicable governmental laws, rules, statutes and regulations relating to its use of the Communication Facility on the Property. Tenant has the right to modify, supplement, replace, upgrade, expand the equipment, increase the number of antennas or relocate the Communication Facility within the Premises at any time during the term of this Agreement. Tenant will be allowed to make such alterations to the Property in order to accomplish Tenant's Changes or to insure that Tenant's Communication Facility complies with all applicable federal, state or local laws, rules or regulations. In the event Tenant desires to modify or upgrade the Communication Facility, and Tenant requires an additional portion of the Property (the "**Additional Premises**") for such modification or upgrade, Landlord agrees to lease to Tenant the Additional Premises, upon the same terms and conditions set forth herein, except that the Rent shall increase, in conjunction with the lease of the Additional Premises by the amount equivalent to the then-current per square foot rental rate charged by Landlord to Tenant times the square footage of the Additional Premises. Landlord agrees to take such actions and enter into and deliver to Tenant such documents as Tenant reasonably requests in order to effect and memorialize the lease of the Additional Premises to Tenant.

3. **TERM.**

(a) The initial lease term will be five (5) years (the "**Initial Term**"), commencing on the effective date of written notification by Tenant to Landlord of Tenant's exercise of the Option (the "**Term Commencement Date**"). The Initial Term will terminate on the fifth (5th) anniversary of the Term Commencement Date.

(b) This Agreement will automatically renew for four (4) additional five (5) year term(s) (each five (5) year term shall be defined as an "**Extension Term**"), upon the same terms and conditions unless Tenant notifies Landlord in writing of Tenant's intention not to renew this Agreement at least sixty (60) days prior to the expiration of the existing Term.

(c) If, at least sixty (60) days prior to the end of the final Extension Term, either Landlord or Tenant has not given the other written notice of its desire that the term of this Agreement end at the expiration of the final Extension Term, then upon the expiration of the final Extension Term this Agreement shall continue in force upon the same covenants, terms and conditions for a further term of one (1) year, and for annual terms thereafter ("**Annual Term**") until terminated by either party by giving to the other written notice of its intention to so terminate at least six (6) months prior to the end of any such Annual Term. Monthly rental during such annual terms shall be equal to the rent paid for the last month of the final Extension Term. If Tenant remains in possession of the Premises after the termination of this Agreement then Tenant will be deemed to be occupying the Premises on a month-to-month basis (the "**Holdover Term**"), subject to the terms and conditions of this Agreement.

(d) The Initial Term, any Extension Terms, any Annual Terms and any Holdover Term are collectively referred to as the Term (the "**Term**").

4. **RENT.**

(a) Commencing in the month following the date that Tenant commences construction (the "**Rent Commencement Date**"), Tenant will pay Landlord on or before the fifth (5th) day of each calendar month in advance [REDACTED] (the "**Rent**"), at the address set forth above. In any partial month occurring after the Rent Commencement Date, Rent will be prorated. The initial Rent payment will be forwarded by Tenant to Landlord within forty-five (45) days after the Rent Commencement Date.

(b) In year one (1) of each Extension Term, the monthly Rent will increase by [REDACTED] percent [REDACTED] over the Rent paid during the previous Term.

(c) All charges payable under this Agreement such as utilities and taxes shall be billed by Landlord within one (1) year from the end of the calendar year in which the charges were incurred; any charges beyond such period shall not be billed by Landlord, and shall not be payable by Tenant. The foregoing shall not apply to monthly Rent which is due and payable without a requirement that it be billed by Landlord. The provisions of this subsection shall survive the termination or expiration of this Agreement.

5. **APPROVALS.**

(a) Landlord agrees that Tenant's ability to use the Premises is contingent upon the suitability of the Premises and Property for Tenant's Permitted Use and Tenant's ability to obtain and maintain all Government Approvals. Landlord authorizes Tenant to prepare, execute and file all required applications to obtain Government Approvals for Tenant's Permitted Use under this Agreement and agrees to reasonably assist Tenant with such applications and with obtaining and maintaining the Government Approvals.

(b) Tenant has the right to obtain a title report or commitment for a leasehold title policy from a title insurance company of its choice and to have the Property surveyed by a surveyor of its choice.

(c) Tenant may also perform and obtain, at Tenant's sole cost and expense, soil borings, percolation tests, engineering procedures, environmental investigation or other tests or reports on, over, and under the Property, necessary to determine if Tenant's use of the Premises will be compatible with Tenant's engineering specifications, system, design, operations or Government Approvals.

6. **TERMINATION.** This Agreement may be terminated, without penalty or further liability, as follows:

(a) by either party on thirty (30) days prior written notice, if the other party remains in default under Section 15 of this Agreement after the applicable cure periods;

(b) by Tenant upon written notice to Landlord, if Tenant is unable to obtain, or maintain, any required approval(s) or the issuance of a license or permit by any agency, board, court or other governmental authority necessary for the construction or operation of the Communication Facility as now or hereafter intended by Tenant; or if Tenant determines, in its sole discretion that the cost of or delay in obtaining or retaining the same is commercially unreasonable;

(c) by Tenant, upon written notice to Landlord, if Tenant determines, in its sole discretion, due to the title report results or survey results, that the condition of the Premises is unsatisfactory for its intended uses;

(d) by Tenant upon written notice to Landlord for any reason or no reason, at any time prior to commencement of construction by Tenant; or

(e) by Tenant upon sixty (60) days' prior written notice to Landlord for any reason or no reason, so long as Tenant pays Landlord a termination fee equal to three (3) months' Rent, at the then-current rate, provided, however, that no such termination fee will be payable on account of the termination of this Agreement by Tenant under any one or more of Sections 5 Approvals, 6(a) Termination, 6(b) Termination, 6(c) Termination, 8 Interference, 11(d) Environmental, 18 Condemnation, 19 Casualty or 24(l) Severability of this Agreement.

7. **INSURANCE.** During the Term, Tenant will carry, at its own cost and expense, the following insurance: (i) "All Risk" property insurance for its property's replacement cost; (ii) Workers' Compensation Insurance as required by law; and (iii) commercial general liability (CGL) insurance with respect to its activities on the Property, such insurance to afford minimum protection of Three Million Dollars (\$3,000,000) combined single limit, per occurrence and in the aggregate, providing coverage for bodily injury and property damage. Tenant's CGL insurance shall contain a provision including Landlord as an additional insured to the extent of the indemnity provided by Tenant under this Agreement. Notwithstanding the foregoing, Tenant shall have the right to self-insure against the risks for which Tenant is required to insure against in this Section. In the event Tenant elects to self-insure its obligation to include Landlord as an additional insured as permitted by the previous sentence, the following provisions shall apply: (1) Landlord shall promptly and no later than seven (7) days after notice thereof provide Tenant with written notice of any claim, demand, lawsuit, or the like for which it seeks coverage pursuant to this Section and provide Tenant with copies of any demands, notices, summonses, or legal papers received in connection with such claim, demand, lawsuit, or the like; (2) Landlord shall not settle any such claim, demand, lawsuit, or the like without the prior written consent of Tenant; (3) Landlord shall fully cooperate with Tenant in the defense of the claim, demand, lawsuit, or the like; (4) Tenant's self-insurance obligation for Landlord shall not extend to claims for punitive damages, exemplary damages, or gross negligence; and (5) such obligation shall not apply when the claim or liability arises from the negligent or intentional act or omission of Landlord, its employees, agents, or independent contractors.

8. **INTERFERENCE.**

(a) Where there are existing radio frequency user(s) on the Property, Landlord will provide Tenant, upon execution of this Agreement, with a list of all existing radio frequency user(s) on the Property to allow Tenant to evaluate the potential for interference. Tenant warrants that its use of the Premises will not interfere with existing radio frequency user(s) on the Property so disclosed by Landlord, as long as those existing radio frequency user(s) operate and continue to operate within their respective frequencies and in accordance with all applicable laws and regulations.

(b) Landlord will not grant, after the date of this Agreement, a lease, license or any other right to any third party for the use of the Property, if such use may in any way adversely affect or interfere with the Communication Facility, the operations of Tenant or the rights of Tenant under this Agreement. Landlord will notify Tenant in writing prior to granting any third party the right to install and operate communications equipment on the Property.

(c) Landlord will not use, nor will Landlord permit its employees, tenants, licensees, invitees, agents or independent contractors to use, any portion of the Property in any way which interferes with the Communication Facility, the operations of Tenant or the rights of Tenant under this Agreement. Landlord will

cause such interference to cease within twenty-four (24) hours after receipt of notice of interference from Tenant. In the event any such interference does not cease within the aforementioned cure period, Landlord shall cease all operations which are suspected of causing interference (except for intermittent testing to determine the cause of such interference) until the interference has been corrected.

(d) For the purposes of this Agreement, "interference" may include, but is not limited to, any use on the Property or Surrounding Property that causes electronic or physical obstruction with, or degradation of, the communications signals from the Communication Facility.

9. INDEMNIFICATION.

(a) Tenant agrees to indemnify, defend and hold Landlord harmless from and against any and all injury, loss, damage or liability (or any claims in respect of the foregoing), costs or expenses (including reasonable attorneys' fees and court costs) arising directly from the installation, use, maintenance, repair or removal of the Communication Facility or Tenant's breach of any provision of this Agreement, except to the extent attributable to the negligent or intentional act or omission of Landlord, its employees, agents or independent contractors.

(b) Landlord agrees to indemnify, defend and hold Tenant harmless from and against any and all injury, loss, damage or liability (or any claims in respect of the foregoing), costs or expenses (including reasonable attorneys' fees and court costs) arising directly from the actions or failure to act of Landlord, its employees or agents, or Landlord's breach of any provision of this Agreement, except to the extent attributable to the negligent or intentional act or omission of Tenant, its employees, agents or independent contractors.

10. WARRANTIES.

(a) Tenant and Landlord each acknowledge and represent that it is duly organized, validly existing and in good standing and has the right, power and authority to enter into this Agreement and bind itself hereto through the party set forth as signatory for the party below.

(b) Landlord represents, warrants and agrees that: (i) Landlord solely owns the Property as a legal lot in fee simple, or controls the Property by lease or license; (ii) the Property is not and will not be encumbered by any liens, restrictions, mortgages, covenants, conditions, easements, leases, or any other agreements of record or not of record, which would adversely affect Tenant's Permitted Use and enjoyment of the Premises under this Agreement; (iii) as long as Tenant is not in default then Landlord grants to Tenant sole, actual, quiet and peaceful use, enjoyment and possession of the Premises; (iv) Landlord's execution and performance of this Agreement will not violate any laws, ordinances, covenants or the provisions of any mortgage, lease or other agreement binding on Landlord; and (v) if the Property is or becomes encumbered by a deed to secure a debt, mortgage or other security interest, Landlord will provide promptly to Tenant a mutually agreeable subordination, non-disturbance and attornment agreement.

11. ENVIRONMENTAL.

(a) Landlord represents and warrants that, except as may be identified in **Exhibit 11** attached to this Agreement, (i) the Property, as of the date of this Agreement, is free of hazardous substances, including asbestos-containing materials and lead paint, and (ii) the Property has never been subject to any contamination or hazardous conditions resulting in any environmental investigation, inquiry or remediation. Landlord and Tenant agree that each will be responsible for compliance with any and all applicable governmental laws, rules, statutes, regulations, codes, ordinances, or principles of common law regulating or imposing standards of liability or standards of conduct with regard to protection of the environment or worker health and safety, as may now or at any time hereafter be in effect, to the extent such apply to that party's activity conducted in or on the Property.

(b) Landlord and Tenant agree to hold harmless and indemnify the other from, and to assume all duties, responsibilities and liabilities at the sole cost and expense of the indemnifying party for, payment of penalties, sanctions, forfeitures, losses, costs or damages, and for responding to any action, notice, claim, order, summons, citation, directive, litigation, investigation or proceeding ("**Claims**"), to the extent arising from that party's breach of its obligations or representations under Section 11(a). Landlord agrees to hold harmless and indemnify Tenant from, and to assume all duties, responsibilities and liabilities at the sole cost and expense of

Landlord for, payment of penalties, sanctions, forfeitures, losses, costs or damages, and for responding to any Claims, to the extent arising from subsurface or other contamination of the Property with hazardous substances prior to the effective date of this Agreement or from such contamination caused by the acts or omissions of Landlord during the Term. Tenant agrees to hold harmless and indemnify Landlord from, and to assume all duties, responsibilities and liabilities at the sole cost and expense of Tenant for, payment of penalties, sanctions, forfeitures, losses, costs or damages, and for responding to any Claims, to the extent arising from hazardous substances brought onto the Property by Tenant.

(c) The indemnifications of this Section 11 specifically include reasonable costs, expenses and fees incurred in connection with any investigation of Property conditions or any clean-up, remediation, removal or restoration work required by any governmental authority. The provisions of this Section 11 will survive the expiration or termination of this Agreement.

(d) In the event Tenant becomes aware of any hazardous substances on the Property, or any environmental, health or safety condition or matter relating to the Property, that, in Tenant's sole determination, renders the condition of the Premises or Property unsuitable for Tenant's use, or if Tenant believes that the leasing or continued leasing of the Premises would expose Tenant to undue risks of liability to a government agency or other third party, Tenant will have the right, in addition to any other rights it may have at law or in equity, to terminate this Agreement upon written notice to Landlord.

12. ACCESS. At all times throughout the Term of this Agreement, and at no additional charge to Tenant, Tenant and its employees, agents, and subcontractors, will have twenty-four (24) hour per day, seven (7) day per week pedestrian and vehicular access ("Access") to and over the Property, from an open and improved public road to the Premises, for the installation, maintenance and operation of the Communication Facility and any utilities serving the Premises. As may be described more fully in **Exhibit 1**, Landlord grants to Tenant an easement for such access and Landlord agrees to provide to Tenant such codes, keys and other instruments necessary for such access at no additional cost to Tenant. Landlord acknowledges that in the event Tenant cannot access the Premises, Tenant shall incur significant damage. If Landlord fails to provide the access granted by this Section 12, such failure shall be a default under this Agreement. In connection with such default, in addition to any other rights or remedies available to Tenant under this Agreement or at law or equity, Landlord shall pay Tenant, as liquidated damages and not as a penalty, \$500.00 per day in consideration of Tenant's damages until Landlord cures such default. Landlord and Tenant agree that Tenant's damages in the event of a denial of access are difficult, if not impossible, to ascertain, and the liquidated damages set forth above are a reasonable approximation of such damages. Upon Tenant's request, Landlord will execute a separate recordable easement evidencing this right. Landlord shall execute a letter granting Tenant access to the Property substantially in the form attached as **Exhibit 12**; upon Tenant's request, Landlord shall execute additional letters during the Term.

13. REMOVAL/RESTORATION. All portions of the Communication Facility brought onto the Property by Tenant will be and remain Tenant's personal property and, at Tenant's option, may be removed by Tenant at any time during the Term. Landlord covenants and agrees that no part of the Communication Facility constructed, erected or placed on the Premises by Tenant will become, or be considered as being affixed to or a part of, the Property, it being the specific intention of Landlord that all improvements of every kind and nature constructed, erected or placed by Tenant on the Premises will be and remain the property of Tenant and may be removed by Tenant at any time during the Term. Within one hundred twenty (120) days of the termination of this Agreement, Tenant will remove all of Tenant's above-ground improvements and Tenant will, to the extent reasonable, restore the Premises to its condition at the commencement of this Agreement, reasonable wear and tear and loss by casualty or other causes beyond Tenant's control excepted. Notwithstanding the foregoing, Tenant will not be responsible for the replacement of any trees, shrubs or other vegetation, nor will Tenant be required to remove from the Premises or the Property any structural steel or any foundations or underground utilities.

14. MAINTENANCE/UTILITIES.

(a) Tenant will keep and maintain the Premises in good condition, reasonable wear and tear and damage from the elements excepted. Landlord will maintain and repair the Property and access thereto and all areas of the Premises where Tenant does not have exclusive control, in good and tenantable condition, subject to reasonable wear and tear and damage from the elements. Landlord will be responsible for maintenance of landscaping on the Property, including any landscaping installed by Tenant as a condition of this Agreement or any required permit.

(b) Tenant will be responsible for paying on a monthly or quarterly basis all utilities charges for electricity, telephone service or any other utility used or consumed by Tenant on the Premises. In the event Tenant cannot secure its own metered electrical supply, Tenant will have the right, at its own cost and expense, to submeter from Landlord. When submetering is required under this Agreement, Landlord will read the meter and provide Tenant with an invoice and usage data on a monthly basis. Landlord agrees that it will not include a markup on the utility charges. Landlord further agrees to provide the usage data and invoice on forms provided by Tenant and to send such forms to such address and/or agent designated by Tenant. Tenant will remit payment within forty-five (45) days of receipt of the usage data and required forms. As noted in Section 4(c) above, any utility fee recovery by Landlord is limited to a twelve (12) month period. If Tenant submeters electricity from Landlord, Landlord agrees to give Tenant at least twenty-four (24) hours advanced notice of any planned interruptions of said electricity. Landlord acknowledges that Tenant provides a communication service which requires electrical power to operate and must operate twenty-four (24) hours per day, seven (7) days per week. If the interruption is for an extended period of time, in Tenant's reasonable determination, Landlord agrees to allow Tenant the right to bring in a temporary source of power for the duration of the interruption. Landlord will not be responsible for interference with, interruption of or failure, beyond the reasonable control of Landlord, of such services to be furnished or supplied by Landlord.

(c) Landlord hereby grants to any utility company providing utility services to Tenant an easement over the Property, from an open and improved public road to the Premises, and upon the Premises, for the purpose of constructing, operating and maintaining such lines, wires, circuits, and conduits, associated equipment cabinets and such appurtenances thereto, as such utility companies may from time to time require in order to provide such services to the Premises. Upon Tenant's or a utility company's request, Landlord will execute a separate recordable easement evidencing this grant, at no cost to Tenant or the public utility.

15. DEFAULT AND RIGHT TO CURE.

(a) The following will be deemed a default by Tenant and a breach of this Agreement: (i) non-payment of Rent if such Rent remains unpaid for more than thirty (30) days after receipt of written notice from Landlord of such failure to pay; or (ii) Tenant's failure to perform any other term or condition under this Agreement within forty-five (45) days after receipt of written notice from Landlord specifying the failure. No such failure, however, will be deemed to exist if Tenant has commenced to cure such default within such period and provided that such efforts are prosecuted to completion with reasonable diligence. Delay in curing a default will be excused if due to causes beyond the reasonable control of Tenant. If Tenant remains in default beyond any applicable cure period, Landlord will have the right to exercise any and all rights and remedies available to it under law and equity.

(b) The following will be deemed a default by Landlord and a breach of this Agreement: (i) failure to provide access to the Premises or to cure an interference problem within twenty-four (24) hours after receipt of written notice of such default; or (ii) Landlord's failure to perform any term, condition or breach of any warranty or covenant under this Agreement within forty-five (45) days after receipt of written notice from Tenant specifying the failure. No such failure, however, will be deemed to exist if Landlord has commenced to cure the default within such period and provided such efforts are prosecuted to completion with reasonable diligence. Delay in curing a default will be excused if due to causes beyond the reasonable control of Landlord. If Landlord remains in default beyond any applicable cure period, Tenant will have: (i) the right to cure Landlord's default and to deduct the costs of such cure from any monies due to Landlord from Tenant, and (ii) any and all other rights available to it under law and equity.

16. **ASSIGNMENT/SUBLEASE.** Tenant will have the right to assign this Agreement or sublease the Premises and its rights herein, in whole or in part, without Landlord's consent. Upon notification to Landlord of such assignment, Tenant will be relieved of all future performance, liabilities and obligations under this Agreement to the extent of such assignment.

17. **NOTICES.**

(a) All notices, requests, demands and communications hereunder will be given by first class certified or registered mail, return receipt requested, or by a nationally recognized overnight courier, postage prepaid, to be effective when properly sent and received, refused or returned undelivered. Notices will be addressed to the parties as follows:

If to Tenant: New Cingular Wireless PCS, LLC
 Attn: Network Real Estate Administration
 Re: Cell Site #EV3166; Cell Site Name:Kevil_(KY)
 Fixed Asset No: 10146926
 12555 Cingular Way, Suite 1300
 Alpharetta, GA 30004

With a copy to: New Cingular Wireless PCS, LLC
 Attn: AT&T Legal Department
 Re: Cell Site #: EV3166; Cell Site Name: Kevil (KY)
 Fixed Asset No: 10146926
 1025 Lenox Park Blvd., 5th floor
 Atlanta, GA 30319

The copy sent to the Legal Department is an administrative step which alone does not constitute legal notice.

If to Landlord: Richard Owen
 668 Veterans Ave.
 Kevil, KY 42053

Either party hereto may change the place for the giving of notice to it by thirty (30) days' prior written notice to the other as provided herein.

(b) In the event of a change in ownership, transfer or sale of the Property, within ten (10) days of such transfer, Landlord or its successor will send the documents listed below in this subsection (b) to Tenant. Until Tenant receives all such documents, Tenant shall not be responsible for any failure to make payments under this Agreement and reserves the right to hold payments due under this Agreement.

- i. Old deed to Property
- ii. New deed to Property
- iii. Bill of Sale or Transfer
- iv. Copy of current Tax Bill
- v. New IRS Form W-9
- vi. Completed and Signed AT&T Payment Direction Form
- vii. Full contact information for new Landlord including phone number(s)

18. **CONDEMNATION.** In the event Landlord receives notification of any condemnation proceedings affecting the Property, Landlord will provide notice of the proceeding to Tenant within forty-eight (48) hours. If a condemning authority takes all of the Property, or a portion sufficient, in Tenant's sole determination, to

render the Premises unsuitable for Tenant, this Agreement will terminate as of the date the title vests in the condemning authority. The parties will each be entitled to pursue their own separate awards in the condemnation proceeds, which for Tenant will include, where applicable, the value of its Communication Facility, moving expenses, prepaid Rent, and business dislocation expenses. Tenant will be entitled to reimbursement for any prepaid Rent on a prorata basis.

19. CASUALTY. Landlord will provide notice to Tenant of any casualty or other harm affecting the Property within forty-eight (48) hours of the casualty or other harm. If any part of the Communication Facility or Property is damaged by casualty or other harm as to render the Premises unsuitable, in Tenant's sole determination, then Tenant may terminate this Agreement by providing written notice to Landlord, which termination will be effective as of the date of such casualty or other harm. Upon such termination, Tenant will be entitled to collect all insurance proceeds payable to Tenant on account thereof and to be reimbursed for any prepaid Rent on a prorata basis. Landlord agrees to permit Tenant to place a temporary transmission and reception facilities on the Property, but only until such time as Tenant is able to activate a replacement transmission facility at another location; notwithstanding the termination of the Agreement, such temporary facilities will be governed by all of the terms and conditions of this Agreement, including Rent. If Landlord or Tenant undertakes to rebuild or restore the Premises and/or the Communication Facility, as applicable, Landlord agrees to permit Tenant to place temporary transmission and reception facilities on the Property at no additional Rent until the reconstruction of the Premises and/or the Communication Facility is completed. If Landlord determines not to rebuild or restore the Premises, Landlord will notify Tenant of such determination within thirty (30) days after the casualty or other harm. If Landlord does not so notify Tenant, then Landlord will promptly rebuild or restore the Premises to substantially the same condition as existed before the casualty or other harm. Landlord agrees that the Rent shall be abated until the Premises are rebuilt or restored, unless Tenant places temporary transmission and reception facilities on the Property.

20. WAIVER OF LANDLORD'S LIENS. Landlord waives any and all lien rights it may have, statutory or otherwise, concerning the Communication Facility or any portion thereof. The Communication Facility shall be deemed personal property for purposes of this Agreement, regardless of whether any portion is deemed real or personal property under applicable law; Landlord consents to Tenant's right to remove all or any portion of the Communication Facility from time to time in Tenant's sole discretion and without Landlord's consent.

21. TAXES. Landlord shall be responsible for payment of all ad valorem taxes levied upon the lands, improvements and other property of Landlord. Tenant shall be responsible for all taxes levied upon Tenant's leasehold improvements (including Tenant's equipment building and tower) on the Premises. Landlord shall provide Tenant with copies of all assessment notices on or including the Premises immediately upon receipt, along with sufficient written documentation detailing any assessment increases attributable to the leasehold improvements, but in no event later than thirty (30) days after receipt by Landlord. If Landlord fails to provide such notice within such time frame, Landlord shall be responsible for all increases in taxes for the year covered by the assessment, and all subsequent years to the extent (a) Landlord continues to fail in providing notice, or (b) Tenant is precluded from challenging such assessment with the appropriate government authorities. Tenant shall have the right to contest, in good faith, the validity or the amount of any tax or assessment levied against the Premises by such appellate or other proceedings as may be appropriate in the jurisdiction, and may defer payment of such obligations, pay same under protest, or take such other steps as Tenant may deem appropriate. This right shall include the ability to institute any legal, regulatory or informal action in the name of Landlord, Tenant, or both, with respect to the valuation of the Premises. Landlord shall cooperate in the institution and prosecution of any such proceedings and will execute any documents required therefor. The expense of any such proceedings shall be borne by Tenant and any refunds or rebates secured as a result of Tenant's action shall belong to Tenant.

22. SALE OF PROPERTY

(a) Landlord shall not be prohibited from the selling, leasing or use of any of the Property or the Surrounding Property except as provided below.

(b) If Landlord, at any time during the Term of this Agreement, decides to rezone or sell, subdivide or otherwise transfer all or any part of the Premises, or all or any part of the Property or Surrounding Property, to a purchaser other than Tenant, Landlord shall promptly notify Tenant in writing, and such rezoning, sale, subdivision or transfer shall be subject to this Agreement and Tenant's rights hereunder. In the event the Property is transferred, the new landlord shall have a duty at the time of such transfer to provide Tenant with a completed IRS Form W-9, or its equivalent, and other related paperwork to effect a transfer in Rent to the new landlord.

(c) Landlord agrees not to sell, lease or use any areas of the Property or Surrounding Property for the installation, operation or maintenance of other wireless communications facilities if such installation, operation or maintenance would interfere with Tenant's Permitted Use or communications equipment as determined by radio propagation tests performed by Tenant in its sole discretion, any such testing to be at the expense of Landlord or Landlord's prospective purchaser, and not Tenant. If the radio frequency propagation tests demonstrate levels of interference unacceptable to Tenant, Landlord shall be prohibited from selling, leasing or using any areas of the Property or the Surrounding Property for purposes of any installation, operation or maintenance of any other wireless communications facility or equipment.

(d) The provisions of this Section shall in no way limit or impair the obligations of Landlord under this Agreement, including interference and access obligations.

23. RENTAL STREAM OFFER. If at any time after the date of this Agreement, Landlord receives a bona fide written offer from a third party seeking an assignment of the rental stream associated with this Agreement ("**Rental Stream Offer**"), Landlord shall immediately furnish Tenant with a copy of the Rental Stream Offer. Tenant shall have the right within twenty (20) days after it receives such copy and representation to match the Rental Stream Offer and agree in writing to match the terms of the Rental Stream Offer. Such writing shall be in the form of a contract substantially similar to the Rental Stream Offer. If Tenant chooses not to exercise this right or fails to provide written notice to Landlord within the twenty (20) day period, Landlord may assign the rental stream pursuant to the Rental Stream Offer, subject to the terms of this Agreement.

24. MISCELLANEOUS.

(a) **Amendment/Waiver.** This Agreement cannot be amended, modified or revised unless done in writing and signed by Landlord and Tenant. No provision may be waived except in a writing signed by both parties. The failure by a party to enforce any provision of this Agreement or to require performance by the other party will not be construed to be a waiver, or in any way affect the right of either party to enforce such provision thereafter.

(b) **Memorandum/Short Form Lease.** Contemporaneously with the execution of this Agreement, the parties will execute a recordable Memorandum or Short Form of Lease substantially in the form attached as **Exhibit 24b**. Either party may record this Memorandum or Short Form of Lease at any time during the Term, in its absolute discretion. Thereafter during the Term of this Agreement, either party will, at any time upon fifteen (15) business days' prior written notice from the other, execute, acknowledge and deliver to the other a recordable Memorandum or Short Form of Lease.

(c) **Limitation of Liability.** Except for the indemnity obligations set forth in this Agreement, and otherwise notwithstanding anything to the contrary in this Agreement, Tenant and Landlord each waives any claims that each may have against the other with respect to consequential, incidental or special damages, however caused, based on any theory of liability.

(d) **Bind and Benefit.** The terms and conditions contained in this Agreement will run with the Property and bind and inure to the benefit of the parties, their respective heirs, executors, administrators, successors and assigns.

(e) **Entire Agreement.** This Agreement and the exhibits attached hereto, all being a part hereof, constitute the entire agreement of the parties hereto and will supersede all prior offers, negotiations and agreements with respect to the subject matter of this Agreement. Exhibits are numbered to correspond to the Section wherein they are first referenced.

(f) **Governing Law.** This Agreement will be governed by the laws of the state in which the Premises are located, without regard to conflicts of law.

(g) **Interpretation.** Unless otherwise specified, the following rules of construction and interpretation apply: (i) captions are for convenience and reference only and in no way define or limit the construction of the terms and conditions hereof; (ii) use of the term "including" will be interpreted to mean "including but not limited to"; (iii) whenever a party's consent is required under this Agreement, except as otherwise stated in this Agreement or as same may be duplicative, such consent will not be unreasonably withheld, conditioned or delayed; (iv) exhibits are an integral part of this Agreement and are incorporated by reference into this Agreement; (v) use of the terms "termination" or "expiration" are interchangeable; (vi) reference to a default will take into consideration any applicable notice, grace and cure periods; (vii) to the extent there is any issue with respect to any alleged, perceived or actual ambiguity in this Agreement, the ambiguity shall not be resolved on the basis of who drafted the Agreement; and (viii) the singular use of words includes the plural where appropriate.

(h) **Affiliates.** All references to "Tenant" shall be deemed to include any Affiliate of New Cingular Wireless PCS, LLC using the Premises for any Permitted Use or otherwise exercising the rights of Tenant pursuant to this Agreement. "Affiliate" means with respect to a party to this Agreement, any person or entity that (directly or indirectly) controls, is controlled by, or under common control with, that party. "Control" of a person or entity means the power (directly or indirectly) to direct the management or policies of that person or entity, whether through the ownership of voting securities, by contract, by agency or otherwise.

(i) **Survival.** Any provisions of this Agreement relating to indemnification shall survive the termination or expiration hereof. In addition, any terms and conditions contained in this Agreement that by their sense and context are intended to survive the termination or expiration of this Agreement shall so survive.

(j) **W-9.** Landlord agrees to provide Tenant with a completed IRS Form W-9, or its equivalent, upon execution of this Agreement and at such other times as may be reasonably requested by Tenant.

(k) **No Electronic Signature/No Option.** The submission of this Agreement to any party for examination or consideration does not constitute an offer, reservation of or option for the Premises based on the terms set forth herein. This Agreement will become effective as a binding Agreement only upon the handwritten legal execution, acknowledgment and delivery hereof by Landlord and Tenant.

(l) **Severability.** If any provision of this Agreement is held invalid, illegal or unenforceable by a court or agency of competent jurisdiction, (a) the validity, legality and enforceability of the remaining provisions of this Agreement are not affected or impaired in any way if the overall purpose of the Agreement is not rendered impossible and the original purpose, intent or consideration is not materially impaired; and (b) the parties shall negotiate in good faith in an attempt to agree to another provision (instead of the provision held to be invalid, illegal or unenforceable) that is valid, legal and enforceable and carries out the parties' intentions to the greatest lawful extent. If any such action or determination renders the overall performance of this Agreement impossible or materially impairs the original purpose, intent or consideration of this Agreement, and the parties are, despite the good faith efforts of each, unable to amend this Agreement to retain the original purpose, intent and consideration in compliance with that court or agency determination, either party may terminate this Agreement upon sixty (60) days' prior written notice to the other party.

(m) **Counterparts.** This Agreement may be executed in two (2) or more counterparts, all of which shall be considered one and the same agreement and shall become effective when one or more counterparts have been signed by each of the parties. All parties need not sign the same counterpart.

(n) **WAIVER OF JURY TRIAL.** EACH PARTY, TO THE EXTENT PERMITTED BY LAW, KNOWINGLY, VOLUNTARILY AND INTENTIONALLY WAIVES ITS RIGHT TO A TRIAL BY JURY IN ANY ACTION OR PROCEEDING UNDER ANY THEORY OF LIABILITY ARISING OUT OF OR IN ANY WAY CONNECTED WITH THIS AGREEMENT OR THE TRANSACTIONS IT CONTEMPLATES.

IN WITNESS WHEREOF, the parties have caused this Agreement to be effective as of the last date written below.

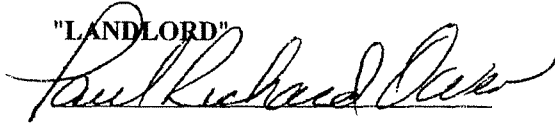
"LANDLORD"

Print Name: Paul Richard Owen
Its: Owner
Date: 2/10/2011

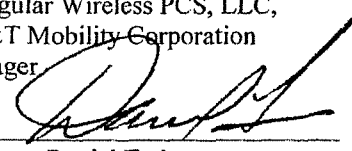
"TENANT"
New Cingular Wireless PCS, LLC,
By: AT&T Mobility Corporation
Its: Manager

By: _____
Print Name: Daniel Toth
Its: Manager of Real Estate and Construction
Date: 3/2/11

[ACKNOWLEDGMENTS APPEAR ON THE NEXT PAGE]

TENANT ACKNOWLEDGMENT

STATE OF Tennessee)

) ss:

COUNTY OF Williamson)

On the 2ND day of MAY, 2011, before me personally appeared Daniel Toth and acknowledged under oath that he is the Manager of Real Estate and Construction of AT&T Mobility Corporation, the Manager of New Cingular Wireless PCS, LLC, the Tenant named in the attached instrument, and as such was authorized to execute this instrument on behalf of the Tenant.

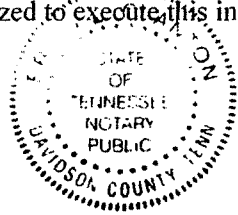

My Commission Expires MAY 8, 2012

Erica L. Clanton

Notary Public: ERICA L. CLANTON

My Commission Expires: MAY 8, 2012

LANDLORD ACKNOWLEDGMENT

STATE OF Kentucky)

) ss:

COUNTY OF Art Large)

On the 10 day of Feb, 2011 before me, personally appeared Richard Owen, who acknowledged under oath, that he/she is the person/officer named in the within instrument, and that he/she executed the same in his/her stated capacity as the voluntary act and deed of the Landlord for the purposes therein contained.

Judy N. Snyder
Notary Public: _____
My Commission Expires: 7-6-13

EXHIBIT 1

DESCRIPTION OF PREMISES

Page 1 of 2

to the Agreement dated MAY 2ND, 2011, by and between Paul Richard Owen, an individual as Landlord, and New Cingular Wireless PCS, LLC, a Delaware limited liability company, as Tenant.

The Premises are described and/or depicted as follows:

Notes:

1. THIS EXHIBIT MAY BE REPLACED BY A LAND SURVEY AND/OR CONSTRUCTION DRAWINGS OF THE PREMISES ONCE RECEIVED BY TENANT.
2. ANY SETBACK OF THE PREMISES FROM THE PROPERTY'S BOUNDARIES SHALL BE THE DISTANCE REQUIRED BY THE APPLICABLE GOVERNMENTAL AUTHORITIES.
3. WIDTH OF ACCESS ROAD SHALL BE THE WIDTH REQUIRED BY THE APPLICABLE GOVERNMENTAL AUTHORITIES, INCLUDING POLICE AND FIRE DEPARTMENTS.
4. THE TYPE, NUMBER AND MOUNTING POSITIONS AND LOCATIONS OF ANTENNAS AND TRANSMISSION LINES ARE ILLUSTRATIVE ONLY. ACTUAL TYPES, NUMBERS AND MOUNTING POSITIONS MAY VARY FROM WHAT IS SHOWN ABOVE.

PARCEL NO. 1:

Beginning at an iron rod (found) at the base of a 20" cherry tree, 45 feet East at a right angle to the centerline of Kentucky Highway No. 473 being in the northwest corner of Ballard County Senior Citizens (Cabinet 1, Drawer 8, Card No. 12806); thence South 70° 50' East for a distance of 178.25 feet to an iron rod (found) at fence corner; thence South 71° 08' East for a distance of 350.40 feet to an iron rod (set) at the ruins of an old fence corner; thence North 17° 15' East for a distance of 184.38 feet, with the line of the Landis and Zimmerman property (Cabinet 1, Drawer 7, Card No. 10966), to an iron rod (set) at a fence corner; thence N 63° 31' West for a distance of 210.82 feet, to an iron rod (set) at a fence post; thence N 74° 51' West for a distance of 217.19 feet, to an iron rod (set) at a fence corner; thence N 74° 51' West for a distance of 46.51 feet to a point; thence N 88° 53' West for a distance of 47.00 feet to a point 50 feet from the centerline of Kentucky Highway No. 473; thence South 70° 38' East for a distance of 150.00 feet to a point in the right of way of Kentucky Hwy. 473, 200 feet from the centerline; thence South 19° 22' West for a distance of 120.00 feet, in the right of way of Kentucky Highway No. 473, 200 feet from the centerline, to a point; thence North 70° 38' West for a distance of 155 feet to a point 45 feet from the centerline of Kentucky Highway No. 473; thence South 19° 22' West for a distance of 60 feet to the point of beginning, containing 1.98 acres. Reference is hereby made to survey of Michael C. Collis, P.L.S., dated September 8, 1986.

Exhibit J

NORTH BASED ON PVA MAP

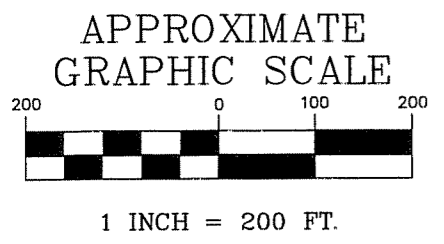
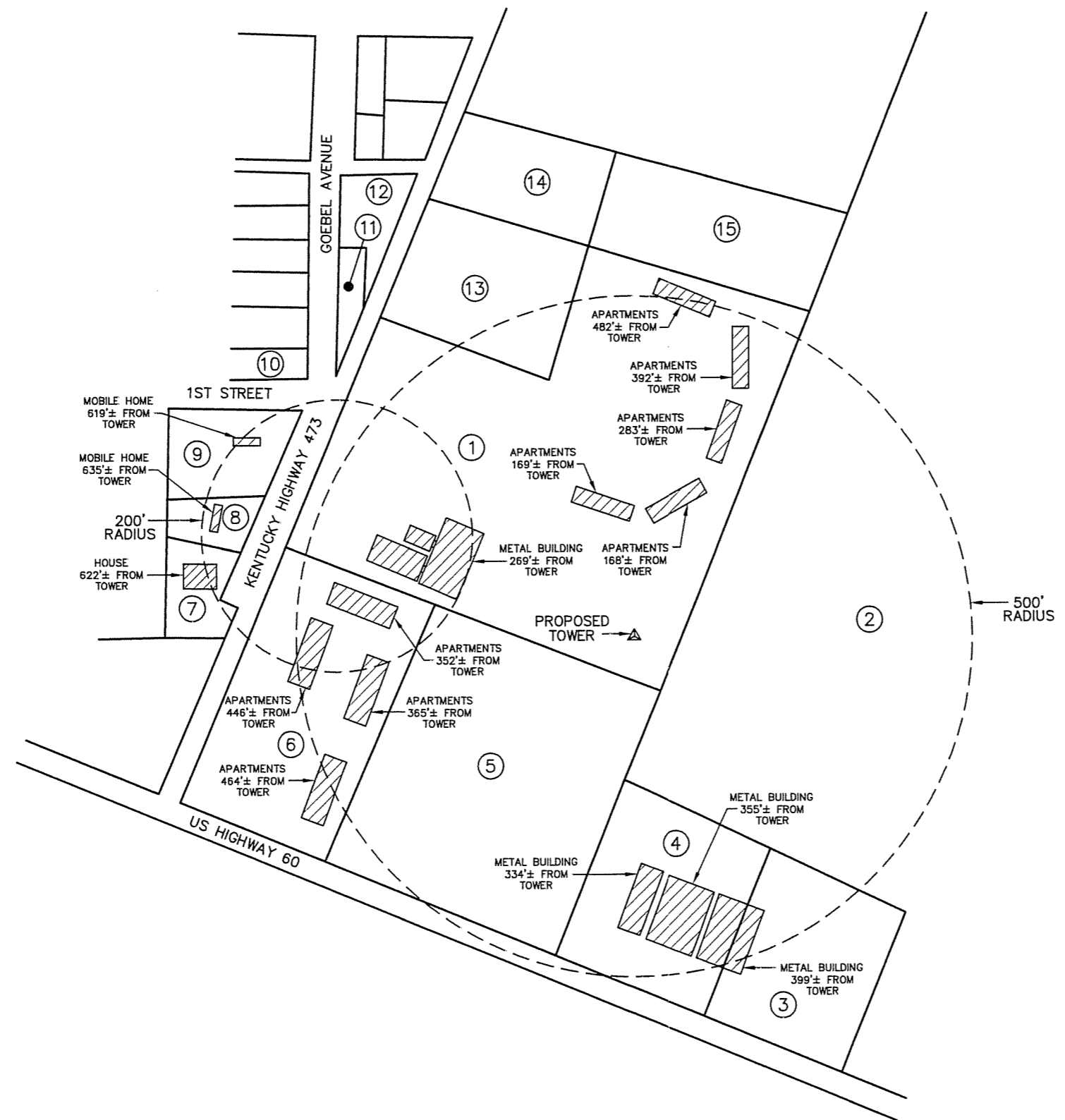

THIS MAP IS FOR GENERAL INFORMATIONAL PURPOSES ONLY AND IS NOT A BOUNDARY SURVEY.

GENERAL NOTE:
 ALL INFORMATION SHOWN HEREON WAS OBTAINED FROM THE RECORDS OF BALLARD COUNTY, KENTUCKY PROPERTY VALUATION ADMINISTRATION OFFICE ON 02/16/11. THE PROPERTY VALUATION ADMINISTRATION RECORDS MAY NOT REFLECT THE CURRENT OWNERS AND ADDRESS DUE TO THE INACCURACIES AND TIME LAPSE IN UPDATING FILES. THE COUNTY PROPERTY VALUATION ADMINISTRATION EXPRESSLY DISCLAIMS ANY WARRANTY FOR THE CONTENT AND ANY ERRORS CONTAINED IN THEIR FILES.



BTM ENGINEERING, INC.
 3001 TAYLOR SPRINGS DRIVE
 LOUISVILLE, KENTUCKY 40220
 (502) 459-8402 PHONE
 (502) 459-8427 FAX

STATE OF KENTUCKY
 TODD CHRISTOPHER LOPP
 3917
 LICENSED PROFESSIONAL LAND SURVEYOR

Todd Lopp 5-18-11

SITE NAME: KEVIL

SITE I.D.: EV3166

SITE ADDRESS:
 174 NEW LIBERTY CHURCH ROAD
 KEVIL, BALLARD CO., KY 42053

LEASE AREA: 10,000 SQ. FT.

PROPERTY OWNER:
 PAUL RICHARD OWEN
 PO BOX 190
 KEVIL, KY 42053

TAX MAP NUMBER: 64

PARCEL NUMBER: 60

SOURCE OF TITLE:
 DEED BOOK 93, PAGE 263

LATITUDE: 37° 04' 55.854"N
 LONGITUDE: 88° 52' 56.943"W

NO.	REVISION/ISSUE	DATE
1	ISSUE	4/6/11
2	UPDATE ADJOINER	5/18/11

TITLE:
500' RADIUS VICINITY MAP

SHEET:
C-1



BTM ENGINEERING, INC.
3001 TAYLOR SPRINGS DRIVE
LOUISVILLE, KENTUCKY 40220
(502) 459-8402 PHONE
(502) 459-8427 FAX

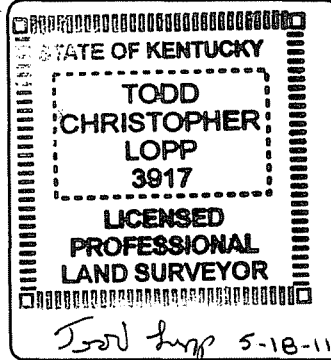

SITE NAME: KEVIL

SITE I.D.: EV3166

SITE ADDRESS:
174 NEW LIBERTY CHURCH ROAD
KEVIL, BALLARD CO., KY 42053

LEASE AREA: 10,000 SQ. FT.

PROPERTY OWNER:
PAUL RICHARD OWEN
PO BOX 190
KEVIL, KY 42053

TAX MAP NUMBER: 64

PARCEL NUMBER: 60

SOURCE OF TITLE:
DEED BOOK 93, PAGE 263

LATITUDE: 37° 04' 55.854"N
LONGITUDE: 88° 52' 56.943"W

NO.	REVISION/ISSUE	DATE
1	ISSUE	4/6/11
2	UPDATE ADJOINER	5/18/11

TITLE:
500' RADIUS
OWNER'S LIST

SHEET:
C-1A

- ① TAX MAP 64, PARCEL 60
PAUL R. OWEN
DBA CHERRY HILL APARTMENTS
PO BOX 190
KEVIL, KY 42053
- ② TAX MAP 64, PARCEL 58-01
BOBBY D. HOOK ESTATE
C/O BEN KENNEDY
714 KENTUCKY AVENUE
KEVIL, KY 42053
- ③ TAX MAP 64, PARCEL 64
PHILIP ALEX AND
BETTY JO BABB
156 BABB LANE
KEVIL, KY 42053
- ④ TAX MAP 64, PARCEL 63
EDDY S. C. LEE AND ELLIS ASHKENAZI
526 34TH AVENUE
SAN FRANCISCO, CA 94121
- ⑤ TAX MAP 64, PARCEL 62
JESSE F. HOOK ESTATE
C/O BILLY GENE HOOK
470 SHELBY ROAD
KEVIL, KY 42053
- ⑥ TAX MAP 64, PARCEL 61
BALLARD COUNTY SENIOR
CITIZENS COUNCIL, INC.
PO BOX 508
BARLOW, KY 42024
- ⑦ TAX MAP 66A, PARCEL 15-06-01
NATHAN W. HIGGINS
48 COUNTY ROAD 130B
KEVIL, KY 42053
- ⑧ TAX MAP 66A, PARCEL 15-06
KYLE D. MINTON
173 NEW LIBERTY CHURCH ROAD
KEVIL, KY 42053

- ⑨ TAX MAP 66A, PARCEL 15-05
ELWOOD AND EDOENA TURNER
PO BOX 293
LA CENTER, KY 42056
- ⑩ TAX MAP 66A, PARCEL 15-04
ANTHONY WAYNE VANCE
207 GOBEL AVENUE
KEVIL, KY 42053
- ⑪ TAX MAP 66A, PARCEL 15-03
EDWIN EARL FREEMAN
PO BOX 62
KEVIL, KY 42053
- ⑫ TAX MAP 66A, PARCEL 14-03
CYNTHIA A. ENGELHARDT
PO BOX 165
KEVIL, KY 42053
- ⑬ TAX MAP 64, PARCEL 60-01
PAUL R. OWEN
DBA CHERRY HILL APARTMENTS
PO BOX 190
KEVIL, KY 42053
- ⑭ TAX MAP 64, PARCEL 59
GEORGE AND BRENDA WRAY
272 NEW LIBERTY CHURCH ROAD
KEVIL, KY 42053
- ⑮ TAX MAP 64, PARCEL 59
GEORGE AND BRENDA WRAY
272 NEW LIBERTY CHURCH ROAD
KEVIL, KY 42053

GENERAL NOTE:
ALL INFORMATION SHOWN HEREON WAS OBTAINED FROM THE RECORDS OF BALLARD COUNTY, KENTUCKY PROPERTY VALUATION ADMINISTRATION OFFICE ON 02/16/11. THE PROPERTY VALUATION ADMINISTRATION RECORDS MAY NOT REFLECT THE CURRENT OWNERS AND ADDRESS DUE TO THE INACCURACIES AND TIME LAPSE IN UPDATING FILES. THE COUNTY PROPERTY VALUATION ADMINISTRATION EXPRESSLY DISCLAIMS ANY WARRANTY FOR THE CONTENT AND ANY ERRORS CONTAINED IN THEIR FILES.

BRIGGS LAW OFFICE, PSC

1301 Clear Springs Trace | Suite 205 | Louisville, Kentucky 40223

Telephone [502] 412-9222 | Facsimile [866] 333-4563

todd@briggslawoffice.net

TODD R. BRIGGS

also admitted in Colorado

Notice of Proposed Construction Wireless Telecommunications Facility

Bobby D. Hook Estate
C/o Ben Kennedy
714 Kentucky Ave
Kevil, KY 42053

Via Certified Mail Return Receipt Requested

Dear Landowner:

New Cingular Wireless PCS, LLC is applying to the Kentucky Public Service Commission (the "Commission") for a Certificate of Public Convenience and Necessity to construct and operate a new wireless telecommunications facility located at 174 New Liberty Church Road, Kevil, Kentucky 42053. A map showing the location is attached. The proposed facility will include a 195 foot monopole tower, plus related ground facilities.

This notice is being sent to you because the Ballard County Property Valuation Administrator's records indicate that you own property that is within a 500' radius of the proposed tower site OR is contiguous to the property on which the tower is to be constructed.

The Commission invites your comments regarding the proposed construction and wants you to be aware of your right to intervene in the Commission's proceedings on this application. Your comments and request for intervention should be addressed to: Kentucky Public Service Commission, Executive Director, 211 Sower Boulevard, P.O. Box 615, Frankfort, Kentucky 40602. Please refer to case number 2011-00168 in any correspondence.

Sincerely,

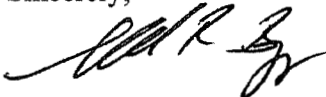

Todd R. Briggs
Counsel for New Cingular Wireless PCS, LLC

Enclosure

BRIGGS LAW OFFICE, PSC

1301 Clear Springs Trace | Suite 205 | Louisville, Kentucky 40223

Telephone [502] 412-9222 | Facsimile [866] 333-4563

todd@briggslawoffice.net

TODD R. BRIGGS
also admitted in Colorado

Notice of Proposed Construction Wireless Telecommunications Facility

Philip Alex and Betty Jo Babb
156 Babb Lane
Kevil, KY 42053

Via Certified Mail Return Receipt Requested

Dear Landowner:

New Cingular Wireless PCS, LLC is applying to the Kentucky Public Service Commission (the "Commission") for a Certificate of Public Convenience and Necessity to construct and operate a new wireless telecommunications facility located at 174 New Liberty Church Road, Kevil, Kentucky 42053. A map showing the location is attached. The proposed facility will include a 195 foot monopole tower, plus related ground facilities.

This notice is being sent to you because the Ballard County Property Valuation Administrator's records indicate that you own property that is within a 500' radius of the proposed tower site OR is contiguous to the property on which the tower is to be constructed.

The Commission invites your comments regarding the proposed construction and wants you to be aware of your right to intervene in the Commission's proceedings on this application. Your comments and request for intervention should be addressed to: Kentucky Public Service Commission, Executive Director, 211 Sower Boulevard, P.O. Box 615, Frankfort, Kentucky 40602. Please refer to case number 2011-00168 in any correspondence.

Sincerely,



Todd R. Briggs
Counsel for New Cingular Wireless PCS, LLC

Enclosure

BRIGGS LAW OFFICE, PSC

1301 Clear Springs Trace | Suite 205 | Louisville, Kentucky 40223

Telephone [502] 412-9222 | Facsimile [866] 333-4563

todd@briggslawoffice.net

TODD R. BRIGGS
also admitted in Colorado

Notice of Proposed Construction Wireless Telecommunications Facility

Eddy S. C. Lee and Ellis Ashkenazi
526 34th Ave
San Francisco, CA 94121

Via Certified Mail Return Receipt Requested

Dear Landowner:

New Cingular Wireless PCS, LLC is applying to the Kentucky Public Service Commission (the "Commission") for a Certificate of Public Convenience and Necessity to construct and operate a new wireless telecommunications facility located at 174 New Liberty Church Road, Kevil, Kentucky 42053. A map showing the location is attached. The proposed facility will include a 195 foot monopole tower, plus related ground facilities.

This notice is being sent to you because the Ballard County Property Valuation Administrator's records indicate that you own property that is within a 500' radius of the proposed tower site OR is contiguous to the property on which the tower is to be constructed.

The Commission invites your comments regarding the proposed construction and wants you to be aware of your right to intervene in the Commission's proceedings on this application. Your comments and request for intervention should be addressed to: Kentucky Public Service Commission, Executive Director, 211 Sower Boulevard, P.O. Box 615, Frankfort, Kentucky 40602. Please refer to case number 2011-00168 in any correspondence.

Sincerely,



Todd R. Briggs
Counsel for New Cingular Wireless PCS, LLC

Enclosure

BRIGGS LAW OFFICE, PSC

1301 Clear Springs Trace | Suite 205 | Louisville, Kentucky 40223

Telephone [502] 412-9222 | Facsimile [866] 333-4563

todd@briggslawoffice.net

TODD R. BRIGGS
also admitted in Colorado

Notice of Proposed Construction Wireless Telecommunications Facility

Jesse F. Hook Estate
C/o Billy Gene Hook
470 Shelby Road
Kevil, KY 42053

Via Certified Mail Return Receipt Requested

Dear Landowner:

New Cingular Wireless PCS, LLC is applying to the Kentucky Public Service Commission (the "Commission") for a Certificate of Public Convenience and Necessity to construct and operate a new wireless telecommunications facility located at 174 New Liberty Church Road, Kevil, Kentucky 42053. A map showing the location is attached. The proposed facility will include a 195 foot monopole tower, plus related ground facilities.

This notice is being sent to you because the Ballard County Property Valuation Administrator's records indicate that you own property that is within a 500' radius of the proposed tower site OR is contiguous to the property on which the tower is to be constructed.

The Commission invites your comments regarding the proposed construction and wants you to be aware of your right to intervene in the Commission's proceedings on this application. Your comments and request for intervention should be addressed to: Kentucky Public Service Commission, Executive Director, 211 Sower Boulevard, P.O. Box 615, Frankfort, Kentucky 40602. Please refer to case number 2011-00168 in any correspondence.

Sincerely,

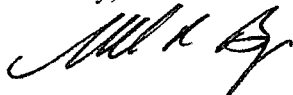

Todd R. Briggs
Counsel for New Cingular Wireless PCS, LLC

Enclosure

BRIGGS LAW OFFICE, PSC

1301 Clear Springs Trace | Suite 205 | Louisville, Kentucky 40223

Telephone [502] 412-9222 | Facsimile [866] 333-4563

todd@briggslawoffice.net

TODD R. BRIGGS
also admitted in Colorado

Notice of Proposed Construction Wireless Telecommunications Facility

Ballard County Senior Citizens Council, Inc.
P.O. Box 508
Barlow, KY 42024

Via Certified Mail Return Receipt Requested

Dear Landowner:

New Cingular Wireless PCS, LLC is applying to the Kentucky Public Service Commission (the "Commission") for a Certificate of Public Convenience and Necessity to construct and operate a new wireless telecommunications facility located at 174 New Liberty Church Road, Kevil, Kentucky 42053. A map showing the location is attached. The proposed facility will include a 195 foot monopole tower, plus related ground facilities.

This notice is being sent to you because the Ballard County Property Valuation Administrator's records indicate that you own property that is within a 500' radius of the proposed tower site OR is contiguous to the property on which the tower is to be constructed.

The Commission invites your comments regarding the proposed construction and wants you to be aware of your right to intervene in the Commission's proceedings on this application. Your comments and request for intervention should be addressed to: Kentucky Public Service Commission, Executive Director, 211 Sower Boulevard, P.O. Box 615, Frankfort, Kentucky 40602. Please refer to case number 2011-00168 in any correspondence.

Sincerely,



Todd R. Briggs
Counsel for New Cingular Wireless PCS, LLC

Enclosure

BRIGGS LAW OFFICE, PSC

1301 Clear Springs Trace | Suite 205 | Louisville, Kentucky 40223

Telephone [502] 412-9222 | Facsimile [866] 333-4563

todd@briggslawoffice.net

TODD R. BRIGGS
also admitted in Colorado

Notice of Proposed Construction Wireless Telecommunications Facility

Nathan W. Higgins
48 County Road 1308
Kevil, KY 42053

Via Certified Mail Return Receipt Requested

Dear Landowner:

New Cingular Wireless PCS, LLC is applying to the Kentucky Public Service Commission (the "Commission") for a Certificate of Public Convenience and Necessity to construct and operate a new wireless telecommunications facility located at 174 New Liberty Church Road, Kevil, Kentucky 42053. A map showing the location is attached. The proposed facility will include a 195 foot monopole tower, plus related ground facilities.

This notice is being sent to you because the Ballard County Property Valuation Administrator's records indicate that you own property that is within a 500' radius of the proposed tower site OR is contiguous to the property on which the tower is to be constructed.

The Commission invites your comments regarding the proposed construction and wants you to be aware of your right to intervene in the Commission's proceedings on this application. Your comments and request for intervention should be addressed to: Kentucky Public Service Commission, Executive Director, 211 Sower Boulevard, P.O. Box 615, Frankfort, Kentucky 40602. Please refer to case number 2011-00168 in any correspondence.

Sincerely,

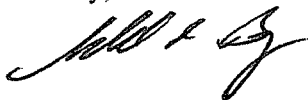

Todd R. Briggs
Counsel for New Cingular Wireless PCS, LLC

Enclosure

BRIGGS LAW OFFICE, PSC

1301 Clear Springs Trace | Suite 205 | Louisville, Kentucky 40223

Telephone [502] 412-9222 | Facsimile [866] 333-4563

todd@briggslawoffice.net

TODD R. BRIGGS
also admitted in Colorado

Notice of Proposed Construction Wireless Telecommunications Facility

Kyle D. Minton
173 New Liberty Church Road
Kevil, KY 42053

Via Certified Mail Return Receipt Requested

Dear Landowner:

New Cingular Wireless PCS, LLC is applying to the Kentucky Public Service Commission (the "Commission") for a Certificate of Public Convenience and Necessity to construct and operate a new wireless telecommunications facility located at 174 New Liberty Church Road, Kevil, Kentucky 42053. A map showing the location is attached. The proposed facility will include a 195 foot monopole tower, plus related ground facilities.

This notice is being sent to you because the Ballard County Property Valuation Administrator's records indicate that you own property that is within a 500' radius of the proposed tower site OR is contiguous to the property on which the tower is to be constructed.

The Commission invites your comments regarding the proposed construction and wants you to be aware of your right to intervene in the Commission's proceedings on this application. Your comments and request for intervention should be addressed to: Kentucky Public Service Commission, Executive Director, 211 Sower Boulevard, P.O. Box 615, Frankfort, Kentucky 40602. Please refer to case number 2011-00168 in any correspondence.

Sincerely,

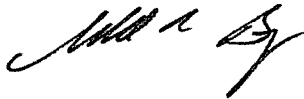

Todd R. Briggs
Counsel for New Cingular Wireless PCS, LLC

Enclosure

BRIGGS LAW OFFICE, PSC

1301 Clear Springs Trace | Suite 205 | Louisville, Kentucky 40223

Telephone [502] 412-9222 | Facsimile [866] 333-4563

todd@briggslawoffice.net

TODD R. BRIGGS
also admitted in Colorado

Notice of Proposed Construction Wireless Telecommunications Facility

Elwood and Edoena Turner
P.O. Box 293
LaCenter, KY 42056

Via Certified Mail Return Receipt Requested

Dear Landowner:

New Cingular Wireless PCS, LLC is applying to the Kentucky Public Service Commission (the "Commission") for a Certificate of Public Convenience and Necessity to construct and operate a new wireless telecommunications facility located at 174 New Liberty Church Road, Kevil, Kentucky 42053. A map showing the location is attached. The proposed facility will include a 195 foot monopole tower, plus related ground facilities.

This notice is being sent to you because the Ballard County Property Valuation Administrator's records indicate that you own property that is within a 500' radius of the proposed tower site OR is contiguous to the property on which the tower is to be constructed.

The Commission invites your comments regarding the proposed construction and wants you to be aware of your right to intervene in the Commission's proceedings on this application. Your comments and request for intervention should be addressed to: Kentucky Public Service Commission, Executive Director, 211 Sower Boulevard, P.O. Box 615, Frankfort, Kentucky 40602. Please refer to case number 2011-00168 in any correspondence.

Sincerely,



Todd R. Briggs
Counsel for New Cingular Wireless PCS, LLC

Enclosure

BRIGGS LAW OFFICE, PSC

1301 Clear Springs Trace | Suite 205 | Louisville, Kentucky 40223

Telephone [502] 412-9222 | Facsimile [866] 333-4563

todd@briggslawoffice.net

TODD R. BRIGGS
also admitted in Colorado

Notice of Proposed Construction Wireless Telecommunications Facility

Anthony Wayne Vance
207 Gobel Ave
Kevil, KY 42053

Via Certified Mail Return Receipt Requested

Dear Landowner:

New Cingular Wireless PCS, LLC is applying to the Kentucky Public Service Commission (the "Commission") for a Certificate of Public Convenience and Necessity to construct and operate a new wireless telecommunications facility located at 174 New Liberty Church Road, Kevil, Kentucky 42053. A map showing the location is attached. The proposed facility will include a 195 foot monopole tower, plus related ground facilities.

This notice is being sent to you because the Ballard County Property Valuation Administrator's records indicate that you own property that is within a 500' radius of the proposed tower site OR is contiguous to the property on which the tower is to be constructed.

The Commission invites your comments regarding the proposed construction and wants you to be aware of your right to intervene in the Commission's proceedings on this application. Your comments and request for intervention should be addressed to: Kentucky Public Service Commission, Executive Director, 211 Sower Boulevard, P.O. Box 615, Frankfort, Kentucky 40602. Please refer to case number 2011-00168 in any correspondence.

Sincerely,



Todd R. Briggs
Counsel for New Cingular Wireless PCS, LLC

Enclosure

BRIGGS LAW OFFICE, PSC

1301 Clear Springs Trace | Suite 205 | Louisville, Kentucky 40223

Telephone [502] 412-9222 | Facsimile [866] 333-4563

todd@briggslawoffice.net

TODD R. BRIGGS
also admitted in Colorado

Notice of Proposed Construction Wireless Telecommunications Facility

Edwin Earl Freeman
P.O. Box 62
Kevil, KY 42053

Via Certified Mail Return Receipt Requested

Dear Landowner:

New Cingular Wireless PCS, LLC is applying to the Kentucky Public Service Commission (the "Commission") for a Certificate of Public Convenience and Necessity to construct and operate a new wireless telecommunications facility located at 174 New Liberty Church Road, Kevil, Kentucky 42053. A map showing the location is attached. The proposed facility will include a 195 foot monopole tower, plus related ground facilities.

This notice is being sent to you because the Ballard County Property Valuation Administrator's records indicate that you own property that is within a 500' radius of the proposed tower site OR is contiguous to the property on which the tower is to be constructed.

The Commission invites your comments regarding the proposed construction and wants you to be aware of your right to intervene in the Commission's proceedings on this application. Your comments and request for intervention should be addressed to: Kentucky Public Service Commission, Executive Director, 211 Sower Boulevard, P.O. Box 615, Frankfort, Kentucky 40602. Please refer to case number 2011-00168 in any correspondence.

Sincerely,

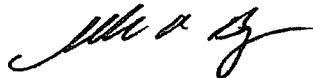

Todd R. Briggs
Counsel for New Cingular Wireless PCS, LLC

Enclosure

BRIGGS LAW OFFICE, PSC

1301 Clear Springs Trace | Suite 205 | Louisville, Kentucky 40223

Telephone [502] 412-9222 | Facsimile [866] 333-4563

todd@briggslawoffice.net

TODD R. BRIGGS
also admitted in Colorado

Notice of Proposed Construction Wireless Telecommunications Facility

Cynthia A. Engelhardt
P.O. Box 165
Kevil, KY 42053

Via Certified Mail Return Receipt Requested

Dear Landowner:

New Cingular Wireless PCS, LLC is applying to the Kentucky Public Service Commission (the "Commission") for a Certificate of Public Convenience and Necessity to construct and operate a new wireless telecommunications facility located at 174 New Liberty Church Road, Kevil, Kentucky 42053. A map showing the location is attached. The proposed facility will include a 195 foot monopole tower, plus related ground facilities.

This notice is being sent to you because the Ballard County Property Valuation Administrator's records indicate that you own property that is within a 500' radius of the proposed tower site OR is contiguous to the property on which the tower is to be constructed.

The Commission invites your comments regarding the proposed construction and wants you to be aware of your right to intervene in the Commission's proceedings on this application. Your comments and request for intervention should be addressed to: Kentucky Public Service Commission, Executive Director, 211 Sower Boulevard, P.O. Box 615, Frankfort, Kentucky 40602. Please refer to case number 2011-00168 in any correspondence.

Sincerely,

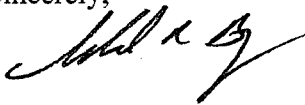

Todd R. Briggs
Counsel for New Cingular Wireless PCS, LLC

Enclosure

BRIGGS LAW OFFICE, PSC

1301 Clear Springs Trace | Suite 205 | Louisville, Kentucky 40223

Telephone [502] 412-9222 | Facsimile [866] 333-4563

todd@briggslawoffice.net

TODD R. BRIGGS
also admitted in Colorado

Notice of Proposed Construction Wireless Telecommunications Facility

Paul R. Owen
dba Cherry Hill Apartments
P.O. Box 190
Kevil, KY 42053

Via Certified Mail Return Receipt Requested

Dear Landowner:

New Cingular Wireless PCS, LLC is applying to the Kentucky Public Service Commission (the "Commission") for a Certificate of Public Convenience and Necessity to construct and operate a new wireless telecommunications facility located at 174 New Liberty Church Road, Kevil, Kentucky 42053. A map showing the location is attached. The proposed facility will include a 195 foot monopole tower, plus related ground facilities.

This notice is being sent to you because the Ballard County Property Valuation Administrator's records indicate that you own property that is within a 500' radius of the proposed tower site OR is contiguous to the property on which the tower is to be constructed.

The Commission invites your comments regarding the proposed construction and wants you to be aware of your right to intervene in the Commission's proceedings on this application. Your comments and request for intervention should be addressed to: Kentucky Public Service Commission, Executive Director, 211 Sower Boulevard, P.O. Box 615, Frankfort, Kentucky 40602. Please refer to case number 2011-00168 in any correspondence.

Sincerely,



Todd R. Briggs
Counsel for New Cingular Wireless PCS, LLC

Enclosure

BRIGGS LAW OFFICE, PSC

1301 Clear Springs Trace | Suite 205 | Louisville, Kentucky 40223

Telephone [502] 412-9222 | Facsimile [866] 333-4563

todd@briggslawoffice.net

TODD R. BRIGGS
also admitted in Colorado

Notice of Proposed Construction Wireless Telecommunications Facility

George and Brenda Wray
272 New Liberty Church Road
Kevil, KY 42053

Via Certified Mail Return Receipt Requested

Dear Landowner:

New Cingular Wireless PCS, LLC is applying to the Kentucky Public Service Commission (the "Commission") for a Certificate of Public Convenience and Necessity to construct and operate a new wireless telecommunications facility located at 174 New Liberty Church Road, Kevil, Kentucky 42053. A map showing the location is attached. The proposed facility will include a 195 foot monopole tower, plus related ground facilities.

This notice is being sent to you because the Ballard County Property Valuation Administrator's records indicate that you own property that is within a 500' radius of the proposed tower site OR is contiguous to the property on which the tower is to be constructed.

The Commission invites your comments regarding the proposed construction and wants you to be aware of your right to intervene in the Commission's proceedings on this application. Your comments and request for intervention should be addressed to: Kentucky Public Service Commission, Executive Director, 211 Sower Boulevard, P.O. Box 615, Frankfort, Kentucky 40602. Please refer to case number 2011-00168 in any correspondence.

Sincerely,

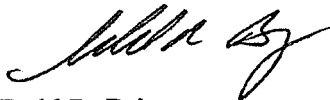

Todd R. Briggs
Counsel for New Cingular Wireless PCS, LLC

Enclosure

Exhibit K

BRIGGS LAW OFFICE, PSC

1301 Clear Springs Trace | Suite 205 | Louisville, Kentucky 40223

Telephone [502] 412-9222 | Facsimile [866] 333-4563

todd@briggslawoffice.net

TODD R. BRIGGS

also admitted in Colorado

Via Certified Mail Return Receipt Requested

Honorable Vickie Viniard
Ballard County Judge Executive
437 Ohio Street
Wickliffe, KY 42087

**RE: Notice of Proposal to Construct Wireless Telecommunications Facility
Kentucky Public Service Commission--Case No. 2011-00168**

Dear Judge Viniard:

New Cingular Wireless PCS, LLC is applying to the Kentucky Public Service Commission (the "Commission") for a Certificate of Public Convenience and Necessity to construct and operate a new wireless telecommunications facility located at 174 New Liberty Church Road, Kevil, Kentucky 42053. A map showing the location is attached. The proposed facility will include a 195 foot monopole tower, plus related ground facilities.

You have a right to submit comments regarding the proposed construction to the Commission or to request intervention in the Commission's proceedings on this application.

Your comments and request for intervention should be addressed to: Kentucky Public Service Commission, Executive Director, 211 Sower Boulevard, P.O. Box 615, Frankfort, Kentucky 40602. Please refer to case number 2011-00168 in any correspondence.

Sincerely,

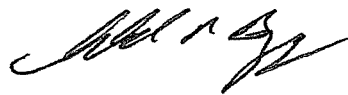

Todd R. Briggs
Counsel for New Cingular Wireless PCS, LLC

Enclosure

Exhibit L

PUBLIC NOTICE

New Cingular Wireless PCS, LLC
proposes to construct a
telecommunications

TOWER

near this site. If you have
any questions please contact:

Briggs Law Office, PSC
1301 Clear Springs Trace
Suite 205
Louisville, KY 40223
(502) 412-9222

or
Executive Director
Public Service Commission
211 Sower Boulevard
P.O. Box 615
Frankfort, KY 40602

Please refer to Commission's
Case #2011-00168
in your correspondence.

PUBLIC NOTICE

New Cingular Wireless PCS, LLC
proposes to construct a
telecommunications

TOWER

on this site. If you have
any questions please contact:

Briggs Law Office, PSC
1301 Clear Springs Trace
Suite 205
Louisville, KY 40223
(502) 412-9222

or
Executive Director
Public Service Commission
211 Sower Boulevard
P.O. Box 615
Frankfort, KY 40602

Please refer to Commission's
Case #2011-00168
in your correspondence.

Exhibit M

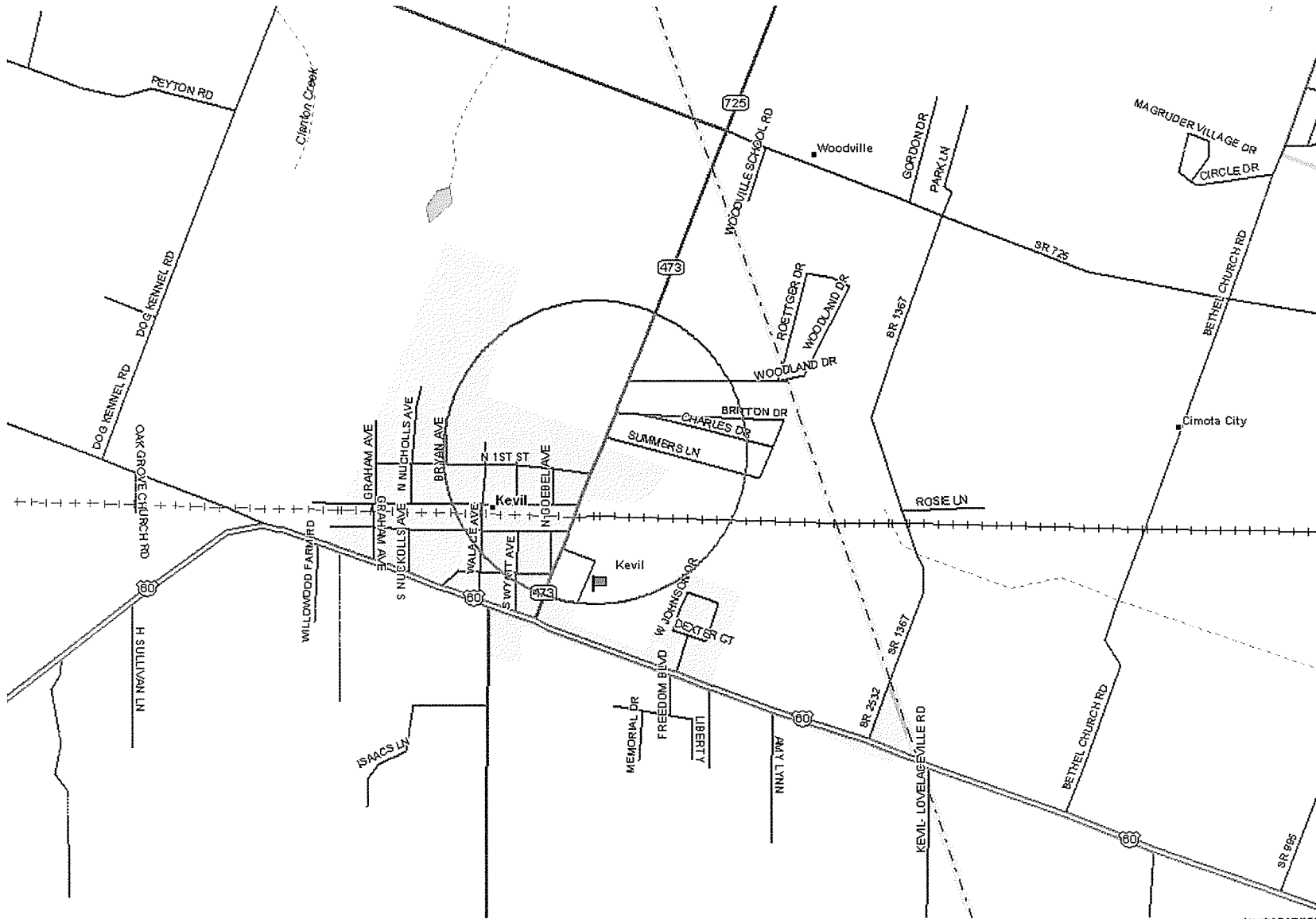

Street Atlas
© 2008 USA

Zoom Level
13-1

Latitude
1137.10163°

Longitude
W88.86876°

Magnify:
100%

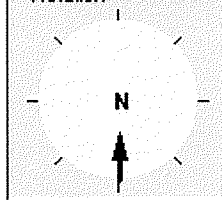

Kevil Search Area

Exhibit N



AT&T Mobility
3231 N. Green River Rd.
Evansville, IN 47715

Sherri A Lewis
RF Design Engineer - Kentucky
3231 North Green River Road
Evansville, IN 47715
Phone: 812-457-3327

March 21, 2011

To Whom It May Concern:

Dear Sir or Madam:

This letter is to serve as documentation that the proposed AT&T site called Kevil, to be located in Ballard County, KY at Latitude 37-04-55.85 North, Longitude 088-52-56.94 West, has been designed, and will be built and operated in accordance with all applicable FCC and FAA regulations.

A handwritten signature in black ink, appearing to read "S. A. Lewis".

Sherri A Lewis
RF Design Engineer



AT&T Mobility
3231 N. Green River Rd.
Evansville, IN 47715

Sherri A Lewis
RF Design Engineer - Kentucky
3231 North Green River Road
Evansville, IN 47715
Phone: 812-457-3327

March 21, 2011

To Whom It May Concern:

Dear Sir or Madam:

This letter is to state that there is no more suitable location reasonably available from which adequate service can be provided in the area of the proposed Kevil site. There are no collocation opportunities available as there are no tall structures located within this site's search area.

A handwritten signature in black ink that reads "Sherri A Lewis".

Sherri A Lewis
RF Design Engineer



AT&T Mobility
3231 N. Green River Rd.
Evansville, IN 47715

Sherri A Lewis
RF Design Engineer - Kentucky
3231 North Green River Road
Evansville, IN 47715
Phone: 812-457-3327

March 21, 2011

To Whom It May Concern:

Dear Sir or Madam:

This letter is to state the need of the proposed AT&T site called Kevil, to be located in Ballard County, KY. The Kevil site is necessary to improve coverage and eliminate interference in eastern Ballard County. This site will improve the coverage and reduce interference on US Hwy 60, Hwy 473, in the town of Kevil, and the surrounding area. Our closest existing site to this area is over 4.3 miles away; thus, there is currently no dominant server in this area. This lack of a dominant server causes many quality issues for the customers. Currently customers in this area experience high dropped calls and may experience poor call quality or areas of no service. With the addition of this site, the customers in this area of Ballard County will experience improved reliability, better in-building coverage, and improved access to emergency 911 services.

A handwritten signature in black ink, appearing to read "Sherri A Lewis".

Sherri A Lewis
RF Design Engineer