

COMMONWEALTH OF KENTUCKY
BEFORE THE PUBLIC SERVICE COMMISSION

In the Matter of:

APPROVAL OF THE)
INTERCONNECTION AGREEMENT)
NEGOTIATED BY BELL SOUTH)
TELECOMMUNICATIONS, INC. AND)
KENTUCKY RSA NO. 1 PARTNERSHIP,) CASE NO. 97-146
PURSUANT TO SECTIONS 251 AND)
252 OF THE TELECOMMUNICATIONS)
ACT OF 1996)

O R D E R

On March 27, 1997, BellSouth Telecommunications, Inc. ("BellSouth") and Kentucky RSA No. 1 Partnership ("RSA No. 1") submitted to the Commission their negotiated agreement for interconnection. The agreement was negotiated pursuant to the Telecommunications Act of 1996 ("1996 Act"), 47 U.S.C. Sections 251 and 252. Section 252(e) of the 1996 Act requires the parties to an interconnection agreement adopted by negotiation to submit the agreement for approval to the Commission.

The Commission has extensively reviewed the agreement and finds that no portion of the agreement discriminates against a telecommunications carrier not a party to the agreement. The Commission also finds that the implementation of this agreement is consistent with the public interest, convenience, and necessity.

RSA No. 1 must comply with all relevant Commission mandates for serving in this Commonwealth.

The Commission, having been otherwise sufficiently advised, HEREBY ORDERS that:

1. The negotiated agreement between BellSouth and RSA No. 1, which is attached hereto and incorporated herein, is approved.

2. RSA No. 1 shall file a tariff for local service prior to providing local service giving 30 days notice to the Commission and shall comply with all Commission regulations and orders as directed.

Done at Frankfort, Kentucky, this 16th day of April, 1997.

PUBLIC SERVICE COMMISSION

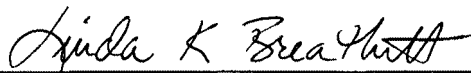
Chairman

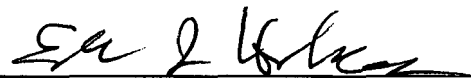
Vice Chairman

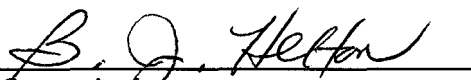
Commissioner

ATTEST:

Executive Director

AGREEMENT

THIS AGREEMENT is made by and between BellSouth Telecommunications, Inc., ("BellSouth"), a Georgia corporation, and Kentucky RSA No. 1 Partnership ("Carrier"), a Kentucky general partnership, acting through its Managing Partner, GTE Mobilnet of Richmond Incorporated, a Virginia corporation, and shall be deemed effective as of March 1, 1997. This agreement may refer to either BellSouth or Carrier or both as a "party" or "parties."

WITNESSETH

WHEREAS, BellSouth is a local exchange telecommunications company authorized to provide telecommunications services in the states of Alabama, Florida, Georgia, Kentucky, Louisiana, Mississippi, North Carolina, South Carolina, and Tennessee; and

WHEREAS, Carrier is a Commercial Mobile Radio Service ("CMRS") provider licensed by the Federal Communications Commission ("FCC") to provide Commercial Mobile Radio Service ("CMRS") in the states of Alabama, Florida, Kentucky, North Carolina, South Carolina and Tennessee; and

WHEREAS, the parties wish to interconnect their facilities and exchange traffic for the purposes of fulfilling their obligations pursuant to sections 251, 252 and 271 of the Telecommunications Act of 1996 and to replace any and all other prior agreements, both written and oral;

NOW THEREFORE, in consideration of the mutual agreements contained herein, BellSouth and Carrier agree as follows:

I. Definitions

A. Affiliate is defined as a person that (directly or indirectly) owns or controls, is owned or controlled by, or is under common ownership or control with, another person. For purposes of this paragraph, the term "own" means to own an equity interest (or equivalent thereof) of more than 10 percent.

B. Commission is defined as the appropriate regulatory agency in each of BellSouth's nine state region: Alabama, Florida, Georgia, Kentucky, Louisiana, Mississippi, North Carolina, South Carolina, and Tennessee.

C. Intermediary function is defined as the delivery, pursuant to an appropriate agreement or Commission directive, of local or toll (using traditional landline definitions) traffic to or from a local exchange carrier other than BellSouth; an ALEC; or another telecommunications company such as a CMRS provider other than Carrier through the network of BellSouth or Carrier from or to an end user of BellSouth or Carrier.

D. Local Traffic is defined for purposes of reciprocal compensation under this Agreement as: (1) any telephone call that originates on the network of Carrier within a Major Trading Area ("MTA") and terminates on the network of BellSouth in the same MTA and within the Local Access and Transport Area ("LATA") in which the call is handed off from Carrier to BellSouth, and (2) any telephone call that originates on the network of BellSouth that is handed off to Carrier in the same LATA in which the call originates and terminates on the network of Carrier in the MTA in which the call is handed off from BellSouth to Carrier. For purposes of this Agreement, LATA shall have the same definition as that contained in the Telecommunications Act of 1996, and MTA shall have the same definition as that contained in §51.701 of the FCC's rules.

E. Local Interconnection is defined for purposes of this Agreement as 1) the delivery of local traffic to be terminated on each party's local network so that end users of either party have the ability to reach end users of the other party without the use of any access code or substantial delay in the processing of the call; and 2) the LEC unbundled network features, functions, and capabilities set forth in this Agreement.

F. Percent of Interstate Usage (PIU) is defined as a factor to be applied to terminating access services minutes of use to obtain those minutes that should be rated as interstate access services minutes of use. The numerator includes all interstate "nonintermediary" minutes of use, less any interstate minutes of use for Terminating Party Pays services, such as 800 Services. The denominator includes all "nonintermediary" Toll and access minutes of use less all minutes attributable to terminating party pays services.

G. Percent Local Usage (PLU) is defined as a factor to be applied to terminating minutes of use. The numerator shall include all "nonintermediary" Local minutes of use. The denominator is the total minutes of use including Local and Toll.

H. Telecommunications Act of 1996 ("Act") means Public Law 104-104 of the United States Congress effective February 8, 1996. The Act amended the Communications Act of 1934 (47, U.S.C. Section 1 et. seq.).

I. Multiple Exchange Carrier Access Billing ("MECAB") means the document prepared by the Billing Committee of the Ordering and Billing Forum ("OBF"), which functions under the auspices of the Carrier Liaison Committee of the Alliance for Telecommunications Industry Solutions ("ATIS") and by Bellcore as Special Report SR-

BDS-000983, Containing the recommended guidelines for the billing of Exchange Service access provided by two or more LECs and/or ALECs or by one LEC in two or more states within a single LATA.

J. Toll Traffic is defined as all traffic that is not Local Traffic.

II. Purpose

The parties desire to enter into this Agreement consistent with all applicable federal, state and local statutes, rules and regulations in effect as of the date of its execution including, without limitation, the Act at Sections 251, 252 and 271 and to replace any and all other prior agreements, both written and oral, concerning the terms and conditions of interconnection. The access and interconnection obligations contained herein enable Carrier to provide CMRS service, competing telephone exchange service and private line service, in those areas where Carrier is authorized to provide such service, within the nine state region of BellSouth.

III. Term of the Agreement

The term of this Agreement shall be two years, beginning on the effective date and shall automatically renew for additional six (6) month terms unless either party provides written notice of termination to the other party at least sixty (60) days prior to the end of the then-current term.

IV. Local Interconnection

A. The delivery of Local Traffic between the parties shall be reciprocal and compensation will be mutual according to the provisions of this Agreement. The parties agree that the exchange of traffic on BellSouth's interLATA EAS routes shall be considered as Local Traffic and compensation for the termination of such traffic shall be pursuant to the terms of this section. EAS routes are those exchanges within an exchange's Basic Local Calling Area, as defined in Section A3 of BellSouth's General Subscriber Services Tariff.

B. Each party will pay the other for terminating its Local Traffic on the other's network the local interconnection rates as set forth in Attachment B-1, by this reference incorporated herein. The charges for local interconnection are to be billed and paid monthly after appropriate adjustments pursuant to this Agreement are made. Late payment fees, not to exceed 1% per month after the due date may be assessed, if interconnection charges are not paid, within thirty (30) days of the due date of the monthly bill.

V. Modification of Rates

A. The parties agree that the "LATAwide Additive" rate reflected in Attachment B-1 shall be "true-up" (up or down), back to the effective date of this Agreement, based on a final LATAwide Additive price either determined by (i) further agreement as described in subsection (B) hereof or by (ii) a final order (including any appeals) of the Commission having jurisdiction over the subject matter of this Agreement, which final order meets the criteria contained in subsection (C) hereof. The parties acknowledge that the "LATAwide Additive" is intended to compensate BellSouth for the additional transport and other costs associated with transporting calls throughout a larger local calling area defined for CMRS providers with respect to local interconnection (an MTA) versus the traditional wireline local calling areas as currently defined by the appropriate Commissions.

The true-up will consist of:

1) Calculating the difference between the final LATAwide Additive price and initial LATAwide Additive price, reflected in Attachment B-1 of this Agreement. The difference is referred to as the "LATAwide Additive Adjustment" price;

2) Applying the "LATAwide Additive Adjustment" price to all minutes of use for which the initial LATAwide Additive price was applied and billed by the parties since the effective date of this Agreement by multiplying the "LATAwide Additive Adjustment" price by the minutes of use referenced above to arrive at the "True-up Adjustment" amount;

3) If the final LATAwide Additive price is different from the initial LATAwide Additive price, the parties will reciprocally compensate each other in an amount equal to the "True-up Adjustment" amount.

In the event of any disagreement regarding the amount of such "true-up", the parties agree that the Commission having jurisdiction over the matter for the affected state(s) shall be called upon to resolve such differences.

B. The parties agree that they may continue to negotiate as appropriate in an effort to obtain a final LATAwide Additive price, but in the event that no such agreement is reached within six (6) months of this Agreement (which time may be extended by mutual agreement of the parties) either party may petition the Commission(s) having jurisdiction of the rates in dispute to resolve such disputes and to determine the final LATAwide Additive price for the LATAwide traffic covered by this Agreement.

C. Any final order that forms the basis of a "true-up" under this Agreement shall meet the following criteria:

(1) It shall be a proceeding to which BellSouth and Carrier are entitled to be full parties and have had an opportunity to participate in;

(2) It shall apply the provisions of the Act, including but not limited to §252(d)(1) and all effective implementing rules and regulations, provided that said Act and such regulations are in effect at the time of the final order; and

(3) It shall include as an issue the geographic deaveraging of unbundled element rates, which deaveraged rates, if any, are required by said final order, shall form the basis of any "true-up".

VI. Methods of Interconnection

A. The parties agree that there are three appropriate methods of interconnecting facilities: (1) virtual collocation where physical collocation is not practical for technical reasons or because of space limitations; (2) physical collocation; and (3) interconnection via purchase of facilities from either party by the other party. Rates and charges for collocation are set forth in Attachment C-13, incorporated herein by this reference. Facilities may be purchased at rates, terms and conditions set forth in BellSouth's intrastate Switched Access (Section E6) or Special Access (Section E7) services tariff or as contained in Attachment B-1 for local interconnection, incorporated herein by this reference. Type 1, Type 2A and Type 2B interconnection arrangements described in BellSouth's General Subscriber Services Tariff, Section A35, or, in the case of North Carolina, in the North Carolina Connection and Traffic Interchange Agreement effective June 30, 1994, as amended, may also be purchased pursuant to this Agreement provided, however, that such interconnection arrangements shall be provided at the rates, terms and conditions set forth in this Agreement.

B. Reciprocal connectivity shall be established to at least one BellSouth access tandem within every LATA Carrier desires to serve, or Carrier may elect to interconnect directly at an end office for interconnection to end users served by that end office. Such interconnecting facilities shall conform, at a minimum, to the telecommunications industry standard of DS-1 pursuant to Bellcore Standard No. TR-NWT-00499. Signal transfer point, Signaling System 7 ("SS7") connectivity is required at each interconnection point after Carrier implements SS7 capability within its own network. BellSouth will provide out-of-band signaling using Common Channel Signaling Access Capability where technically and economically feasible, in accordance with the technical specifications set forth in the BellSouth Guidelines to Technical Publication, TR-TSV-000905. The parties agree that their facilities shall provide the necessary on-hook, off-hook answer and disconnect supervision and shall hand off calling party number ID when technically feasible. The parties further agree that in the event a party interconnects via the purchase of facilities and/or services from the other party, the

appropriate intrastate tariff, as amended from time to time will apply. In the event that such facilities are used for two-way interconnection, the parties agree that the appropriate charges for such facilities will be reduced by an agreed upon percentage equal to the estimated or actual percentage of traffic on such facilities that terminates on the network of the party purchasing said facilities.

C. Nothing herein shall prevent Carrier from utilizing existing collocation facilities, purchased from the interexchange tariffs, for local interconnection; provided, however, that if Carrier orders new facilities for interconnection or rearranges any facilities presently used for its alternate access business in order to use such facilities for local interconnection hereunder and a BellSouth charge is applicable thereto, BellSouth shall only charge Carrier the lower of the interstate or intrastate tariffed rate or promotional rate.

D. The parties agree to establish trunk groups from the interconnecting facilities of subsection (A) of this section such that each party provides a reciprocal of each trunk group established by the other party. Notwithstanding the foregoing, each party may construct its network, including the interconnecting facilities, to achieve optimum cost effectiveness and network efficiency. BellSouth's treatment of Carrier as to said charges shall be consistent with BellSouth treatment of other local exchange carriers for the same charges. Unless otherwise agreed, BellSouth will provide or bear the cost of all trunk groups for the delivery of traffic from BellSouth to Carrier's Mobile Telephone Switching Offices within BellSouth's service territory, and Carrier will provide or bear the cost of all trunk groups for the delivery of traffic from Carrier to each BellSouth access tandem and end office at which the parties interconnect.

E. The parties agree to use an auditable PLU factor as a method for determining whether traffic is Local or Toll. The same PLU factor will be used for traffic delivered by either party for termination on the other party's network.

F. When the parties provide an access service connection between an interexchange carrier ("IXC") and each other, each party will provide their own access services to the IXC on a multi-bill, multi-tariff meet-point basis. Each party will bill its own access services rates to the IXC with the exception of the interconnection charge. The interconnection charge will be billed by the party providing the intermediary tandem function.

G. The parties agree to adopt MECAB as the terms and conditions for meet point billing for all traffic to which MECAB applies, including traffic terminating to ported numbers, and to employ 30 day billing periods for said arrangements. The recording party agrees to provide to the initial billing company, at no charge, the switched access detailed usage data within a reasonable time after the usage is recorded. The initial billing company will provide the switched access summary usage data to all subsequent billing companies within 10 days of rendering the initial bill to the IXC. The parties agree that there will be technical, administrative, and implementation issues

associated with achieving the intent of this subsection. As such, the parties further agree to work cooperatively toward achieving the intent of this provision within nine months of the effective date of this Agreement.

H. The ordering and provision of all services purchased from BellSouth by Carrier shall be as set forth in the Wireless Service Center Ordering Guidelines or the OLEC-to-BellSouth Ordering Guidelines (Facilities Based), as appropriate, as those guidelines are amended by BellSouth from time to time during the term of this Agreement.

VII. IntraLATA and InterLATA Toll Traffic Interconnection

A. The delivery of intrastate Toll Traffic by a party to the other party shall be reciprocal and compensation will be mutual. For terminating its Toll Traffic on the other party's network, each party will pay BellSouth's intrastate terminating switched access rate, inclusive of the Interconnection Charge and the Carrier Common Line rate elements of the switched access rate as defined in BellSouth's Intrastate Access Services Tariffs. The parties agree that the terminating switched access rates may change during the term of this Agreement and that the appropriate rate shall be the rate in effect when the traffic is terminated.

B. For originating and terminating intrastate or interstate Toll Traffic, each party shall pay the other BellSouth's intrastate or interstate, as appropriate, switched network access service rate elements on a per minute of use basis. Said rate elements shall be as set out in BellSouth's Intrastate Access Services Tariff or BellSouth's Interstate Access Services Tariff as those Tariffs may be amended from time to time during the term of this Agreement. The appropriate charges will be determined by the routing of the call. If Carrier should in the future become the BellSouth end user's presubscribed interexchange carrier or used by the BellSouth end user as an interexchange carrier on a 10XXX basis, BellSouth will charge Carrier the appropriate tariff charges for originating network access services. If BellSouth is serving as the Carrier's end user's presubscribed interexchange carrier or if the Carrier's end user uses BellSouth as an interexchange carrier on a 10XXX basis, Carrier will charge BellSouth the appropriate BellSouth tariff charges for originating network access services.

C. The parties agree that to the extent Carrier provides intraLATA toll service to its customers, it may be necessary for it to interconnect to additional BellSouth access tandems that serve end offices outside the local calling area.

D. Each party agrees to compensate the other, pursuant to the appropriate originating switched access charges, including the database query charge, for the origination of 800 traffic terminated to the other party.

E. Each party will provide to the other party the appropriate records necessary for billing intraLATA 800 customers. The records provided will be in a standard EMR format for a fee of \$0.013 per record.

F. If during the term of this Agreement, either party provides interLATA 800 services, it will compensate the other for the origination of such traffic pursuant to subsection A, above. Each party shall provide the appropriate records for billing pursuant to subsection B, above.

G. Should Carrier require 800 Access Ten Digit Screening Service from BellSouth, it shall have signaling transfer points connecting directly to BellSouth's local or regional signaling transfer point for service control point database query information. Carrier shall utilize SS7 Signaling links, ports and usage as set forth in Attachment C-7, incorporated herein by this reference. Carrier will not utilize switched access FGD service for 800 Access. 800 Access Ten Digit Screening Service is an originating service that is provided via 800 Switched Access Service trunk groups from BellSouth's SSP equipped end office or access tandem providing an IXC identification function and delivery of call to the IXC based on the dialed ten digit number. The rates and charges for said service shall be as set forth in BellSouth's Intrastate Access Services Tariff as said tariff is amended from time to time during the term of this Agreement.

H. The parties acknowledge and agree that this Agreement is intended to govern the interconnection of traffic to and from the parties' networks only. Toll Traffic originated by a party to this Agreement and delivered to the other party for termination to the network of a nonparty telecommunications carrier ("Nonparty Carrier") may be delivered only with the consent of such Nonparty Carrier or pursuant to Commission directive. If a Nonparty Carrier objects to the delivery of such Toll Traffic, then either party to this Agreement may request direction from the Commission. If a Nonparty Carrier consents, then the party performing the intermediary function will bill the other party and the other party shall pay a \$.002 per minute intermediary charge in addition to any charges that the party performing the intermediary function may be obligated to pay to the Nonparty Carrier (collectively called "Toll Intermediary Charges"). The parties agree that the charges that the party performing the intermediary function may be obligated to pay to the Nonparty Carrier may change during the term of this Agreement and that the appropriate rate shall be the rate in effect when the traffic is terminated. The parties agree further that for purposes of this section, and subject to verification by audit eighty percent (80%) of the Toll Traffic delivered to BellSouth by Carrier shall be subject to Toll Intermediary Charges, and none of the Toll Traffic delivered to Carrier by BellSouth shall be subject to the Toll Intermediary Charges.

VIII. Provision of Unbundled Elements

A. BellSouth will offer an unbundled local loop to Carrier at the current rates as set forth in Attachment C-15 incorporated herein by this reference. Special

construction charges, if applicable, will be set forth in BellSouth's Intrastate Special Access Tariff as said tariff is amended from time to time during the term of this Agreement. BellSouth will also offer as a new service loop concentration as set forth in Attachment C-16, incorporated herein by this reference. The parties agree that loop concentration service as offered above is not an unbundled element.

B. BellSouth will offer to Carrier unbundled loop channelization system service which provides the multiplexing function to convert 96 voice grade loops to DS1 level for connection with Carrier's point of interface. Rates are as set forth in Attachment C-16, incorporated herein by this reference.

C. BellSouth will offer to Carrier unbundled local transport from the trunk side of its switch at the rates as set forth in Attachment B-1, incorporated herein by this reference.

D. BellSouth will offer to Carrier unbundled local switching at the rates as set forth in Attachment C-17, incorporated herein by this reference, for the unbundled exchange service port.

E. BellSouth shall, upon request of Carrier, and to the extent technically feasible, provide to Carrier access to its Network Elements for the provision of a Carrier telecommunications service. Any request by Carrier for access to a BellSouth Network Element that is not already available shall be treated as a Network Element bona fide request. Carrier agrees to pay the cost associated with the bona fide request if Carrier cancels the request or fails to purchase the service once completed. Carrier shall provide BellSouth access to its Network Elements as mutually agreed by the parties or as required by the Commission or the FCC.

F. A Network Element obtained by one party from the other party under this section may be used in combination with the facilities of the requesting party only to provide a telecommunications service, including obtaining billing and collection, transmission, and routing of the telecommunications service.

IX. Access To Poles, Ducts, Conduits, and Rights of Way

BellSouth agrees to provide to Carrier, pursuant to 47 U.S.C. § 224, as amended by the Act, nondiscriminatory access to any pole, duct, conduit, or right-of-way owned or controlled by BellSouth.

X. Access to 911/E911 Emergency Network

A. BellSouth and Carrier recognize that 911 and E911 services were designed and implemented primarily as methods of providing emergency services to fixed location subscribers. While BellSouth and Carrier recognize the need to provide

"911-like" service to mobile subscribers, both parties recognize that current technological restrictions prevent an exact duplication of the services provided to fixed location customers. BellSouth agrees to route "911-like" calls received from Carrier to the emergency agency designated by Carrier for such calls. Carrier agrees to provide the information necessary to BellSouth so that each call may be properly routed and contain as much pertinent information as is technically feasible.

B. At a minimum Carrier agrees to provide two dedicated trunk groups originating from Carrier's Mobile Telephone Switching Offices and terminating to the appropriate 911 tandem. These facilities, consisting of a Switched Local Channel from Carrier's point of interface to its Mobile Telephone Switching Office and Switched Dedicated Transport to the 911 tandem, may be purchased from BellSouth at the Switched Dedicated Transport rates set forth in Section E6 of BellSouth's Intrastate Access Service Tariffs. Carrier agrees to assign a pseudo number from its dedicated NXX group to each cell site or to each antenna face. The pseudo number will identify the routing of the call to the appropriate emergency agency as determined by Carrier.

C. BellSouth and Carrier recognize that the technology and regulatory requirements for the provision of "911-like" service by CMRS carriers are evolving and agree to modify or supplement the foregoing in order to incorporate industry accepted technical improvements that Carrier desires to implement and to permit Carrier to comply with applicable regulatory requirements.

XI. Provision of Operator Services

A. BellSouth agrees to provide busy line verification and emergency interrupt services to Carrier's customers pursuant to BellSouth's published Tariffs as the Tariffs are amended from time to time during the term of this Agreement. In the event that during the term of this Agreement Carrier develops or acquires the capability to provide busy line verification and emergency interrupt services, Carrier agrees to provide such services to BellSouth's customers on the same rates, terms and conditions specified in BellSouth's Tariffs.

B. BellSouth will offer to Carrier Operator Call Processing Access Service; and Directory Assistance Access Services (Number Services). Rates, terms and conditions are set forth in Attachment C-8 for Operator Call Processing Access Service and Attachment C-9 for Directory Assistance Access Services. Both Attachments are incorporated herein by this reference.

C. BellSouth will offer to Carrier CMDS Hosting and the Non Sent Paid Report System pursuant to the terms and conditions set forth in Attachment C-11 and C-12 incorporated herein by this reference.

XII. Directory Listings

A. Subject to execution of an agreement between Carrier and BellSouth's affiliate, BellSouth Advertising & Publishing Corporation, ("BAPCO"), substantially in the form set forth in Attachment C-1, (1) listings shall be included in appropriate White Pages or alphabetical directories; (2) Carrier's business subscribers' listings shall also be included in appropriate Yellow Pages, or classified directories; and (3) copies of such directories shall be delivered to Carrier's subscribers.

B. BellSouth will include Carrier's subscriber listings in BellSouth's directory assistance databases and BellSouth will not charge Carrier to maintain the Directory Assistance database. The parties agree to cooperate with each other in formulating appropriate procedures regarding lead time, timeliness, format and content of listing information.

C. BellSouth will provide Carrier a magnetic tape or computer disk containing the proper format for submitting subscriber listings. Carrier will provide BellSouth with its directory listings and daily updates to those listings, including new, changed, and deleted listings, in an industry-accepted format.

D. BellSouth and BAPCO will accord Carrier's directory listing information the same level of confidentiality which BellSouth and BAPCO accords its own directory listing information, and BellSouth shall limit access to Carrier's customer proprietary confidential directory information to those BellSouth or BAPCO employees who are involved in the preparation of listings.

E. Additional listings and optional listings may be provided by BellSouth at the rates set forth in the General Subscriber Services Tariff as the tariff is amended from time to time during the term of this Agreement.

XIII. Access to Telephone Numbers

A. BellSouth, during any period under this Agreement in which it serves as a North American Numbering Plan administrator for its territory, shall ensure that Carrier has nondiscriminatory access to telephone numbers for assignment to its telephone exchange service customers. It is mutually agreed that BellSouth shall provide numbering resources pursuant to the Bellcore Guidelines Regarding Number Assignment and compliance with those guidelines shall constitute nondiscriminatory access to numbers. Carrier agrees that it will complete the NXX code application in accordance with Industry Carriers Compatibility Forum, Central Office Code Assignment Guidelines, ICCF 93-0729-010. This service will be as set forth in Attachment C-2, incorporated herein by this reference.

B. If during the term of this Agreement BellSouth is no longer the North American Numbering Plan administrator, the parties agree to comply with the guidelines, plan or rules adopted pursuant to 47 U.S.C. § 251(e).

XIV. Access to Signaling and Signaling Databases

A. BellSouth will offer to Carrier use of its signaling network and signaling databases on an unbundled basis at BellSouth's published tariffed rates or at unbundled rates that may be available through non-tariffed arrangements. Signaling functionality will be available with both A-link and B-link connectivity.

B. BellSouth agrees to input the NXXs assigned to Carrier into the Local Exchange Routing Guide ("LERG").

C. If Carrier utilizes BellSouth's 800 database for query purposes only, the rates and charges shall be as set forth in Attachment C-4, incorporated herein by this reference.

XV. Network Design and Management

A. The parties agree to work cooperatively to install and maintain reliable interconnected telecommunications networks, including but not limited to, maintenance contact numbers and escalation procedures. BellSouth agrees to provide public notice of changes in the information necessary for the transmission and routing of services using its local exchange facilities or networks, as well as of any other changes that would affect the interoperability of those facilities and networks.

B. The interconnection of all networks will be based upon accepted industry/national guidelines for transmission standards and traffic blocking criteria.

C. The parties will work cooperatively to apply sound network management principles by invoking appropriate network management controls, e.g., call gapping, to alleviate or prevent network congestion.

D. Neither party intends to charge rearrangement, reconfiguration, disconnection, termination or other non-recurring fees that may be associated with the initial reconfiguration of either party's network interconnection arrangement contained in this Agreement. However, the interconnection reconfigurations will have to be considered individually as to the application of a charge. Notwithstanding the foregoing, the parties do intend to charge non-recurring fees for any additions to, or added capacity to, any facility or trunk purchased.

E. The parties agree to provide Common Channel Signaling (CCS) to one another, where available, in conjunction with all traffic in order to enable full interoperability of CLASS features and functions except for call return. All CCS signaling parameters will be provided, including automatic number identification (ANI), originating line information (OLI) calling party category, charge number, etc. All privacy indicators will be honored, and the parties agree to cooperate on the exchange of Transactional Capabilities Application Part (TCAP) messages to facilitate full interoperability of CCS-based features between the respective networks.

F. For network expansion, the parties agree to review engineering requirements on a quarterly basis and establish forecasts for trunk utilization as required by Section VI of this Agreement. New trunk groups will be implemented as stated by engineering requirements for both parties.

G. The parties agree to provide each other with the proper call information, i.e. originated call party number and destination call party number, CIC, and OZZ, including all proper translations for routing between networks and any information necessary for billing where BellSouth provides recording capabilities. The exchange of information is required to enable each party to bill properly.

XVI. Auditing Procedures

A. Upon thirty (30) days written notice, each party must provide the other the ability and opportunity to conduct an annual audit to ensure the proper billing of traffic between the parties. The parties agree to retain records of call detail for a minimum of nine months from which the PLU can be ascertained. The audit shall be accomplished during normal business hours at an office designated by the party being audited. Audit request shall not be submitted more frequently than one (1) time per calendar year. Audits shall be performed by a mutually acceptable independent auditor paid for by the party requesting the audit. The PLU shall be adjusted based upon the audit results and shall apply to the usage for the quarter the audit was completed, the usage for the quarter prior to the completion of the audit, and to the usage for the two quarters following the completion of the audit. If, as a result of an audit, either party is found to have overstated the PLU by twenty percentage points (20%) or more, that party shall reimburse the auditing party for the cost of the audit.

B. For combined interstate and intrastate Carrier traffic terminated by BellSouth over the same facilities, Carrier shall provide a PIU factor to BellSouth. The parties acknowledge that Carrier does not intend to provide interexchange carrier services to BellSouth end-users. Nevertheless, should Carrier in the future provide Toll services through the use of network switched access services, then all jurisdictional report requirements, rules and regulations specified in E2.3.14 of BellSouth's Intrastate Access Services Tariff will apply to Carrier. After the Local Traffic percentage has been determined by use of the PLU factor for application and billing of local interconnection,

the PIU factor will be used for application and billing of interstate and intrastate access charges, as appropriate.

XVII. Liability and Indemnification

A. Neither party shall be liable to the other under this Agreement for indirect, incidental, consequential or special damages, including without limitation, lost profits, regardless of the form of action.

B. Neither party shall be liable to the other for any act or omission of any other telecommunications company providing a portion of a service, nor shall either party hold liable any other telecommunications company providing a portion of a service for any act or omission of BellSouth or Carrier.

C. Neither party is liable for damages to the other party's terminal location, POI nor customer's premises resulting from the furnishing of a service, including but not limited to the installation and removal of equipment and associated wiring, unless the damage is caused by a party's gross or willful negligence or intentional misconduct.

D. Each party shall be indemnified, defended and held harmless by the other party against any claim, loss or damage arising from the other party's acts or omissions under this Agreement, including without limitation: 1) Claims for libel, slander, invasion of privacy, or infringement of copyright arising from the other party's own communications; 2) Claims for patent infringement arising from combining or using the service furnished by either party in connection with facilities or equipment furnished by either party or either party's customer; 3) any claim, loss, or damage claimed by a customer of either party arising from services provided by the other party under this Agreement; or 4) all other claims arising out of an act or omission of the other party in the course of using services provided pursuant to this Agreement.

E. Neither party assumes liability for the accuracy of the data provided to it by the other party.

F. Neither party guarantees or makes any warranty with respect to its services when used in an explosive atmosphere.

G. No license under patents (other than the limited license to use) is granted by either party or shall be implied or arise by estoppel, with respect to any service offered pursuant to this Agreement.

H. Each party's failure to provide or maintain services offered pursuant to this Agreement shall be excused by labor difficulties, governmental orders, civil commotion, criminal actions taken against them, acts of God and other circumstances beyond their reasonable control.

I. The obligations of the parties contained within this section shall survive the expiration of this Agreement.

XVIII. More Favorable Provisions

A. The parties agree that if —

1. the Federal Communications Commission ("FCC") or the Commission having jurisdiction finds that the terms of this Agreement are inconsistent in one or more material respects with any of its or their respective decisions, rules or regulations, or

2. the FCC or the Commission having jurisdiction preempts the effect of this Agreement, then, in either case, upon such occurrence becoming final and no longer subject to administrative or judicial review, the parties shall immediately commence good faith negotiations to conform this Agreement to the requirements of any such decision, rule, regulation or preemption. The revised agreement shall have an effective date that coincides with the effective date of the original FCC or Commission action giving rise to such negotiations. The parties agree that the rates, terms and conditions of any new agreement shall not be applied retroactively to any period prior to such effective date except to the extent that such retroactive effect is expressly required by such FCC or Commission decision, rule, regulation or preemption.

B. In the event that BellSouth, either before or after the effective date of this Agreement, enters into an agreement with any other telecommunications carrier (an "Other Interconnection Agreement") which provides for the provision within a state of any of the arrangements covered by this Agreement upon rates, terms or conditions that differ from the rates, terms and conditions for such arrangements set forth in this Agreement ("Other Terms"), then BellSouth shall be deemed thereby to have offered such arrangements to Carrier upon such Other Terms in that state only, which Carrier may accept as provided in Section XVIII.E. In the event that Carrier accepts such offer within sixty (60) days after the Commission approves such Other Interconnection Agreement pursuant to 47 U.S.C. § 252, or within thirty (30) days after Carrier acquires actual knowledge of an Other Interconnection Agreement not requiring the approval of a Commission pursuant to 47 U.S.C. § 252, as the case may be, such Other Terms shall be effective between BellSouth and Carrier as of the effective date of such Other Interconnection Agreement. In the event that Carrier accepts such offer more than sixty (60) days after the Commission having jurisdiction approves such Other Interconnection Agreement pursuant to 47 U.S.C. § 252, or more than thirty (30) days after acquiring actual knowledge of an Other Interconnection Agreement not requiring the approval of the Commission pursuant to 47 U.S.C. § 252, as the case may be, such Other Terms shall be effective between BellSouth and Carrier as of the date on which Carrier accepts such offer.

C. In the event that after the effective date of this Agreement the FCC or the Commission having jurisdiction enters an order (an "Interconnection Order") requiring BellSouth to provide within a particular state any of the arrangements covered by this Agreement upon Other Terms, then upon such Interconnection Order becoming final and not subject to further administrative or judicial review, BellSouth shall be deemed to have offered such arrangements to Carrier upon such Other Terms, which Carrier may accept as provided in Section XVIII.E. In the event that Carrier accepts such offer within sixty (60) days after the date on which such Interconnection Order becomes final and not subject to further administrative or judicial review, such Other Terms shall be effective between BellSouth and Carrier as of the effective date of such Interconnection Order. In the event that Carrier accepts such offer more than sixty (60) days after the date on which such Interconnection Order becomes final and not subject to further administrative or judicial review, such Other Terms shall be effective between BellSouth and Carrier as of the date on which Carrier accepts such offer.

D. In the event that after the effective date of this Agreement BellSouth files and subsequently receives approval for one or more intrastate or interstate tariffs (each, an "Interconnection Tariff") offering to provide within a particular state any of the arrangements covered by this Agreement upon Other Terms, then upon such Interconnection Tariff becoming effective, BellSouth shall be deemed thereby to have offered such arrangements to Carrier upon such Other Terms in that state only, which Carrier may accept as provided in Section XVIII.E. In the event that Carrier accepts such offer within sixty (60) days after the date on which such Interconnection Tariff becomes effective, such Other Terms shall be effective between BellSouth and Carrier as of the effective date of such Interconnection Tariff. In the event that Carrier accepts such offer more than sixty (60) days after the date on which such Interconnection Tariff becomes effective, such Other Terms shall be effective between BellSouth and Carrier as of the date on which Carrier accepts such offer.

E. In the event that BellSouth is deemed to have offered Carrier the arrangements covered by this Agreement upon Other Terms, Carrier in its sole discretion may accept such offer either —

- 1.** by accepting such Other Terms in their entirety; or
- 2.** by accepting the Other Terms that directly relate to each of the following arrangements as described by lettered category:
 - a.** local interconnection,
 - b.** interLATA and IntraLATA toll traffic interconnection,
 - c.** unbundled access to network elements, which include: local loops, network interface devices, switching capability, interoffice transmission facilities,

signaling networks and call-related databases, operations support systems functions, operator services and directory assistance, and any elements that result from subsequent bone fide requests,

- d. access to poles, ducts, conduits and rights-of-way,
- e. access to 911/E911 emergency network,
- f. collocation, or
- g. access to telephone numbers.

The terms of this Agreement, other than those affected by the Other Terms accepted by Carrier, shall remain in full force and effect.

F. Corrective Payment. In the event that --

1. BellSouth and Carrier revise this Agreement pursuant to Section XVIII.A,
or

2. Carrier accepts a deemed offer of Other Terms pursuant to Section XVIII.E, then BellSouth or Carrier, as applicable, shall make a corrective payment to the other party to correct for the difference between (a) the rates set forth herein and (b) the rates in such revised agreement or Other Terms for the period from (x) the effective date of such revised agreement or Other Terms until (y) the later of the date that the parties execute such revised agreement or the parties implement such Other Terms, plus simple interest at a rate equal to the thirty (30) day commercial paper rate for high-grade, unsecured notes sold through dealers by major corporations in multiples of \$1,000.00 as regularly published in *The Wall Street Journal*.

XIX. Taxes

A. For the purposes of this section, the terms "taxes" and "fees" shall include but not be limited to federal, state or local sales, use, excise, gross receipts or other taxes or tax-like fees of whatever nature and however designated (including tariff surcharges and any fees, charges or other payments, contractual or otherwise, for the use of public streets or rights of way, whether designated as franchise fees or otherwise) imposed, or sought to be imposed, on or with respect to the services furnished hereunder or measured by the charges or payments therefor, excluding any taxes levied on income.

B. Taxes and fees imposed on the providing party, which are neither permitted nor required to be passed on by the providing party, shall be borne and paid by the providing party. Taxes and fees imposed on the purchasing party, which are not

required to be collected and/or remitted by the providing party, shall be borne and paid by the purchasing party.

C. Taxes and fees imposed on the purchasing party shall be borne by the purchasing party, even if the obligation to collect and/or remit such taxes or fees is placed on the providing party. To the extent permitted by applicable law, any such taxes and/or fees shall be shown as separate items on applicable billing documents between the Parties. Notwithstanding the foregoing, the purchasing party shall remain liable for any such taxes and fees regardless of whether they are actually billed by the providing party at the time that the respective service is billed.

D. If the purchasing party determines that in its opinion any such taxes or fees are not payable, the providing party shall not bill such taxes or fees to the purchasing party if the purchasing party provides written certification, reasonably satisfactory to the providing party, stating that it is exempt or otherwise not subject to the tax or fee, setting forth the basis therefor, and satisfying any other requirements under applicable law. If any authority seeks to collect any such tax or fee that was not billed by the providing party, the purchasing party may contest the same in good faith, at its own expense. In any such contest, the purchasing party shall promptly furnish the providing party with copies of all filings in any proceeding, protest, or legal challenge, all rulings issued in connection therewith, and all correspondence between the purchasing party and the taxing authority.

F. If it is ultimately determined that any additional amount of such a tax or fee is due to the imposing authority, the purchasing party shall pay such additional amount, including any interest and penalties thereon. Notwithstanding any provision to the contrary, the purchasing party shall protect, indemnify and hold harmless (and defend at the purchasing party's expense) the providing party from and against any such tax or fee, interest or penalties thereon, or other charges or payable expenses (including reasonable attorney fees) with respect thereto, which are incurred by the providing party in connection with any claim for or contest of any such tax or fee. Each party shall notify the other party in writing of any assessment, proposed assessment or other claim for any additional amount of such a tax or fee by a taxing authority; such notice to be provided, if possible, at least ten (10) days prior to the date by which a response, protest or other appeal must be filed, but in no event later than thirty (30) days after receipt of such assessment, proposed assessment or claim.

G. Taxes and fees imposed on the providing party, which are permitted or required to be passed on by the providing party to its customer, shall be borne by the purchasing party. To the extent permitted by applicable law, any such taxes and/or fees shall be shown as separate items on applicable billing documents between the parties. Notwithstanding the foregoing, the purchasing party shall remain liable for any such taxes and fees regardless of whether they are actually billed by the providing party at the time that the respective service is billed.

H. If the purchasing party disagrees with the providing party's determination as to the application or basis for any such tax or fee, the parties shall consult with respect to the imposition and billing of such tax or fee and with respect to whether to contest the imposition of such tax or fee. Notwithstanding the foregoing, the providing party shall retain ultimate responsibility for determining whether and to what extent any such taxes or fees are applicable, and the purchasing party shall abide by such determination and pay such taxes or fees to the providing party. The providing party shall further retain ultimate responsibility for determining whether and how to contest the imposition of such taxes or fees; provided, however, that any such contest undertaken at the request of the purchasing party shall be at the purchasing party's expense.

I. In the event that all or any portion of an amount sought to be collected must be paid in order to contest the imposition of any such tax or fee, or to avoid the existence of a lien on the assets of the providing party during the pendency of such contest, the purchasing party shall be responsible for such payment and shall be entitled to the benefit of any refund or recovery. If it is ultimately determined that any additional amount of such a tax or fee is due to the imposing authority, the purchasing party shall pay such additional amount, including any interest and penalties thereon.

J. Notwithstanding any provision to the contrary, the purchasing party shall protect, indemnify and hold harmless (and defend at the purchasing party's expense) the providing party from and against any such tax or fee, interest or penalties thereon, or other reasonable charges or payable expenses (including reasonable attorney fees) with respect thereto, which are incurred by the providing party in connection with any claim for or contest of any such tax or fee. Each party shall notify the other party in writing of any assessment, proposed assessment or other claim for any additional amount of such a tax or fee by a taxing authority; such notice to be provided, if possible, at least ten (10) days prior to the date by which a response, protest or other appeal must be filed, but in no event later than thirty (30) days after receipt of such assessment, proposed assessment or claim.

K. In any contest of a tax or fee by one party, the other party shall cooperate fully by providing records, testimony and such additional information or assistance as may reasonably be necessary to pursue the contest. Further, the other party shall be reimbursed for any reasonable and necessary out-of-pocket copying and travel expenses incurred in assisting in such contest.

XX. Treatment of Proprietary and Confidential Information

A. Both parties agree that it may be necessary to provide each other during the term of this Agreement with certain confidential information, including trade secret information, including but not limited to, technical and business plans, technical information, proposals, specifications, drawings, procedures, customer account data,

call detail records and like information (hereinafter collectively referred to as "Information"). Both parties agree that all Information shall be in writing or other tangible form and clearly marked with a confidential, private or proprietary legend and that the Information will be returned to the owner within a reasonable time of the owner's request. Both parties agree that the Information shall not be copied or reproduced in any form. Both parties agree to receive such Information and not disclose such Information to unauthorized third parties. Both parties agree to protect the Information received from distribution, disclosure or dissemination to anyone except employees of the parties with a need to know such Information and which employees agree to be bound by the terms of this Section. Both parties will use the same standard of care to protect Information received as they would use to protect their own confidential and proprietary Information, which shall not be less than reasonable care.

B. Notwithstanding the foregoing, both parties agree that there will be no obligation to protect any portion of the Information that is either: 1) made publicly available by the owner of the Information or lawfully disclosed by a nonparty to this Agreement; 2) lawfully obtained from any source other than the owner of the Information; 3) previously known to the receiving party without an obligation to keep it confidential; 4) permitted to be disclosed by written release from the owner of the Information; or 5) requested by a governmental agency, provided that the party upon whom the request is made shall notify the party who originally provided the confidential information at least seven (7) days prior to its release to the agency.

XXI. Resolution of Disputes

Except as otherwise stated in this Agreement, the parties agree that if any dispute arises as to the interpretation of any provision of this Agreement or as to the proper implementation of this Agreement, the parties will initially refer the issue to the individuals in each company that negotiated the Agreement. If the issue is not resolved within 30 days, either party may petition the Commission for a resolution of the dispute, and/or pursue any other remedy available to it at law or in equity.

XXII. Limitation of Use

The parties agree that this Agreement shall not be proffered by either party in another jurisdiction as evidence of any concession or as a waiver of any position taken by the other party in that jurisdiction or for any other purpose.

XXIII. Waivers

Any failure by either party to insist upon the strict performance by the other party of any of the provisions of this Agreement shall not be deemed a waiver of any of the

provisions of this Agreement, and each party, notwithstanding such failure, shall have the right thereafter to insist upon the specific performance of any and all of the provisions of this Agreement.

XXIV. Governing Law

This Agreement shall be governed by, and construed and enforced in accordance with, the laws of the State of Georgia, without regard to its conflict of laws principles, and the Communications Act of 1934 as amended by the Act.

XXV. Arm's Length Negotiations

This Agreement was executed after arm's length negotiations between the undersigned parties.

XXVI. Notices

A. Every notice, consent, approval, or other communications required or contemplated by this Agreement shall be in writing and shall be delivered in person, via overnight mail, or given by postage prepaid mail, address to:

BellSouth Telecommunications, Inc.
675 W. Peachtree St. N.E.
Suite 4300
Atlanta, Georgia 30375
Attn: Legal Dept. "Wireless" Attorney

Carrier
c/o GTE Mobilnet Service Corp.
245 Perimeter Center Parkway
Atlanta, Georgia 30346
Attn.: Dale Voyles, Esq.

or at such other address as the intended recipient previously shall have designated by written notice to the other party.

B. Where specifically required, notices shall be by certified or registered mail. Unless otherwise provided in this Agreement, notice by mail shall be effective on the date it is officially recorded as delivered by return receipt or equivalent, and in the absence of such record of delivery, it shall be presumed to have been delivered the fifth day, or next business day after the fifth day, after it was deposited in the mails; and by overnight mail, the day after being sent.

XXVII. Entire Agreement

This Agreement and its Attachments, incorporated herein by this reference, sets forth the entire understanding and supersedes prior agreements between the parties

relating to the subject matter contained herein and merges all prior discussions between them, and neither party shall be bound by any definition, condition, provision, representation, warranty, covenant or promise other than as expressly stated in this Agreement or as is contemporaneously or subsequently set forth in writing and executed by a duly authorized officer or representative of the party to be bound thereby. In the event of any conflict between the term(s) of this Agreement and those of an applicable tariff, the terms of this Agreement shall control.

BellSouth Telecommunications, Inc.

**Carrier
Kentucky RSA No. 1 Partnership**

**By its Managing Partner:
GTE Mobilnet of Richmond
Incorporated**

By: Jerry Hendrix

Jerry Hendrix
Name

Director
Title

By: M. Hoppe

MARTIN C. HOPPE
Name

VICE PRESIDENT -
FINANCE AND PLANNING
Title

By: Laura E. Binion

Laura E. Binion
Name

Asst Secretary
Title

Attachment B-1

CMRS Local Interconnection Rates

(All rates are Per Minute of Use)

Alabama

Type 1 (End Office Switched): \$.00671 *
Type 2A (Tandem Switched): \$.00671 *
Type 2B (Dedicated End Office): \$.0017

Florida

Type 1 (End Office Switched): \$.00622 *
Type 2A (Tandem Switched): \$.00622 *
Type 2B (Dedicated End Office): \$.002

Kentucky

Type 1 (End Office Switched): \$.01228*
Type 2A (Tandem Switched): \$.01228*
Type 2B (Dedicated End Office): \$.00991

North Carolina

Type 1 (End Office Switched): \$.00869*
Type 2A (Tandem Switched): \$.00869*
Type 2B (Dedicated End Office): \$.004

South Carolina

Type 1 (End Office Switched): \$.01586 *
Type 2A (Tandem Switched): \$.01586 *
Type 2B (Dedicated End Office): \$.01323

Tennessee

Type 1 (End Office Switched): \$.00577 *
Type 2A (Tandem Switched): \$.00577 *
Type 2B (Dedicated End Office): \$.0019

* These rates include the LATAwide Additive of \$.0025

Attachment B-2

Local Interconnection Service

Service: Toll Switched Access

Description: Provides the Switched Local Channel, Switched Transport, Access Tandem Switching, local end office switching and end user termination functions necessary to complete the transmission of ALEC intrastate and interstate calls from outside the BellSouth's basic local calling area.

Provided in the terminating direction only. Provides trunk side access to a BellSouth tandem/end office for the ALEC's use in terminating long distance communications from the ALEC to BellSouth end users.

Provided at BellSouth tandem/end office as trunk side terminating switching through the use of tandem/end office trunk equipment. The switch trunk equipment may be provided with wink start-pulsing signals and answer and disconnect supervisory signaling, or without signaling when out of band signaling is provided.

Provided with multifrequency address or out of band signaling. Ten digits of the called party number, as appropriate, will be provided by the ALEC's equipment to a BellSouth tandem/end office.

State(s): All

Rates, Terms and Conditions:

In all states, rates, terms and conditions will be applied as set forth in Sections E3 and E6 of BellSouth Telecommunication's, Inc.'s Intrastate Access Service Tariffs and in Sections 3 and 6 of the BellSouth Telecommunication's, Inc. Interstate Access Tariff, F.C.C. No. 1.

Attachment C-1

Unbundled Products and Services and New Services

Service: Subscriber Listing Information

Description: Subscriber primary listing information provided at no charge and in an acceptable format will be published at no charge as standard directory listings in an alphabetical directory published by or for BellSouth at no charge to each ALEC end user customer.

State(s): All

**Rates: (1) No charge for ALEC-1 customer primary listings.
(2) Additional listings and optional listings may be provided by BellSouth at rates set forth in BellSouth's intrastate General Subscriber Services Tariffs.**

AGREEMENT

In consideration of the mutual promises contained herein, BellSouth Advertising & Publishing Corporation, a Georgia corporation ("BAPCO") and _____ a _____ corporation ("CARRIER") agree as follows:

1. **RECITALS.** BAPCO is the publisher of alphabetical and classified directories for certain communities in the southeastern region of the U.S (the "Directories"). CARRIER provides, or intends to provide, local exchange telephone service in communities in which BAPCO publishes Directories. BAPCO and CARRIER hereby establish the terms by which BAPCO will include listings of CARRIER subscribers in such Directories and by which BAPCO will provide such Directories to CARRIER subscribers.

2. **CARRIER OBLIGATIONS.** CARRIER agrees as follows:

(a) CARRIER shall provide to BAPCO, or its designee, at CARRIER's expense and at no charge, listing information concerning its subscribers (designating any who do not desire published listings), consisting of customer name, address, telephone number and all other information reasonably requested by BAPCO as set forth on Exhibit A for use by BAPCO and its affiliates and agents in publishing Directories of whatever type and format and for other derivative purposes. Such subscriber listing information shall be provided in the format and on the schedule set forth in said Exhibit, or as otherwise mutually agreed between the parties from time to time.

(b) CARRIER shall also provide directory delivery information to BAPCO as set forth in Exhibit A for all subscribers.

(c) CARRIER shall advise BAPCO promptly of any directory-related inquiries, requests or complaints which it may receive from CARRIER subscribers and shall provide reasonable cooperation to BAPCO in response to or resolution of the same.

(d) CARRIER shall respond promptly regarding corrections or queries raised by BAPCO to process listing changes requested by subscribers.

3. **BAPCO OBLIGATIONS.** BAPCO agrees as follows:

(a) BAPCO shall include one standard listing for each CARRIER subscriber per hunting group in BAPCO's appropriate local alphabetical Directory as published periodically by BAPCO unless nonlisted or nonpublished status is designated by subscribers. Such listings shall be interfiled with the listings of other local exchange telephone company subscribers and otherwise published in the manner of such other listings according to BAPCO's generally applicable publishing policies and standards.

(b) BAPCO shall publish additional listings, foreign listings and other alphabetical Directory listings of CARRIER subscribers upon their request consistent with BAPCO's generally applicable policies in BAPCO's alphabetical Directories at BAPCO's prevailing rates, terms and conditions.

(c) BAPCO will distribute its regularly published alphabetical and classified Directories to local CARRIER subscribers in accordance with BAPCO's prevailing practices, including delivery following Directory publication and upon establishment of new CARRIER service, if a current Directory for that geographic area has not previously been provided. Such deliveries may include separate advertising materials accompanying the Directories.

(d) BAPCO will include CARRIER information in the customer guide pages of its alphabetical Directories for communities where CARRIER provides local exchange telephone service at the time of publication in accordance with BAPCO's prevailing standards for the same. CARRIER will provide information requested by BAPCO for such purpose on a timely basis.

(e) BAPCO shall make available at no charge to CARRIER or its subscribers one listing for CARRIER business customers per hunting group in one appropriate heading in BAPCO's appropriate local classified directory as published periodically by BAPCO. Such listings shall be published according to BAPCO's generally applicable publishing policies and standards.

(f) BAPCO agrees to solicit, accept and publish directory advertising from business subscribers for CARRIER in communities for which BAPCO publishes classified Directories in the same manner and upon substantially the same terms as it solicits, accepts and publishes advertising from advertisers who are not CARRIER subscribers.

4. PUBLISHING POLICIES. BAPCO shall maintain full authority over its publishing schedules, policies, standards, and practices and over the scope and publishing schedules of its Directories.

5. LIABILITY AND INDEMNITY.

(a) BAPCO's liability to CARRIER for any errors or omissions in directories or for any default otherwise arising hereunder shall be limited to One Dollar (\$1) for errors or omissions in any subscriber listing in any directory published by BAPCO.

(b) Each party agrees to defend, indemnify and hold harmless the other from all damages, claims, suits, losses or expenses, including without limitation costs and attorneys fees, to the extent of such party's relative fault, arising out of or resulting from any error, omission or act of such party hereunder. CARRIER agrees to limit its liability and that of BAPCO by contract with CARRIER's subscribers or by tariff to no more than the cost of service for any errors or omissions in any listings published hereunder for

CARRIER subscribers. Each party shall notify in writing the other promptly of any claimed error or omission affecting this paragraph and of any claim or suit arising hereunder or relating to this Agreement and shall provide reasonable and timely cooperation in its resolution of the same. Without waiver of any rights hereunder, the indemnified party may at its expense undertake its own defense in any such claim or suit.

6. LIMITATION OF LIABILITY. BAPCO's liability to CARRIER for any errors or omission directories or for any default otherwise arising hereunder shall be limited to One Dollar (\$1) for any error or omission in any subscriber listing in any directory published by BAPCO.

7. TERM. This Agreement shall be effective on the date of the last signature hereto for a term of two (2) years and shall relate to Directories published by BAPCO during such period. Thereafter, it shall continue in effect unless terminated by either party upon sixty days prior written notice.

8. ASSIGNMENT. This Agreement shall be binding upon any successors or assigns of the parties during its Term.

9. RELATIONSHIP OF THE PARTIES. This Agreement does not create any joint venture, partnership or employment relationship between the parties or their employees, and the relationship between the parties shall be that of an independent contractor. There shall be no intended third party beneficiaries to this Agreement.

10. NONDISCLOSURE.

(a) During the term of this Agreement it may be necessary for the parties to provide each other with certain information ("Information") considered to be private or proprietary. The recipient shall protect such Information from distribution, disclosure or dissemination to anyone except its employees or contractors with a need to know such Information in conjunction herewith, except as otherwise authorized in writing. All such Information shall be in writing or other tangible form and clearly marked with a confidential or proprietary legend. Information conveyed orally shall be designated as proprietary or confidential at the time of such oral conveyance and shall be reduced to writing within forty-five (45) days.

(b) The parties will not have an obligation to protect any portion of Information which: (1) is made publicly available lawfully by a nonparty to this Agreement; (2) is lawfully obtained from any source other than the providing party; (3) is previously known without an obligation to keep it confidential; (4) is released by the providing party in writing; or (5) commencing two (2) years after the termination date of this Agreement if such Information is not a trade secret under applicable law.

(c) Each party will make copies of the Information only as necessary for its use under the terms hereof, and each such copy will be marked with the same proprietary

notices as appear on the originals. Each party agrees to use the Information solely in support of this Agreement and for no other purpose.

11. FORCE MAJEURE. Neither party shall be responsible to the other for any delay or failure to perform hereunder to the extent caused by fire, flood, explosion, war, strike, riot, embargo, governmental requirements, civic or military authority, act of God, or other similar cause beyond its reasonable control. Each party shall use best efforts to notify the other promptly of any such delay or failure and shall provide reasonable cooperation to ameliorate the effects thereof.

12. PUBLICITY. Neither party shall disclose the terms of this Agreement nor use the trade names or trademarks of the other without the prior express written consent of the other.

13. REPRESENTATIVES AND NOTICES.

(a) Each party shall name one or more representatives for contacts between the parties which shall be authorized to act on its behalf. Such representatives may be changed from time to time upon written notice to the other party.

(b) Notices required by law or under this Agreement shall be given in writing by hand delivery, certified or registered mail, or by facsimile followed by certified or registered mail, addressed to the named representatives of the parties with copies to:

If to BAPCO:

Director-LEC/BST Interface
BellSouth Advertising & Publishing Corporation
Room 270
59 Executive Park South
Atlanta, GA 30329

With Copy to:

Vice President and General Counsel
BellSouth Advertising & Publishing Corporation
Room 430
59 Executive Park South
Atlanta, GA 30329

If to CARRIER:

14. MISCELLANEOUS. This Agreement represents the entire Agreement between the parties with respect to the subject matter hereof and supersedes any previous oral or written communications, representations, understandings, or agreements with respect thereto. It may be executed in counterparts, each of which shall be deemed an original. All prior and contemporaneous written or oral agreements, representations, warranties, statements, negotiations, and /or understandings by and between the parties, whether express or implied, are superseded, and there are no representations or warranties, either oral or written, express or implied, not herein contained. This Agreement shall be governed by the laws of the state of Georgia.

IN WITNESS WHEREOF, the parties have executed this Agreement by their duly authorized representatives in one or more counterparts, each of which shall constitute an original, on the dates set forth below.

BELLSOUTH ADVERTISING &
PUBLISHING CORPORATION

By: _____
(Signature)

Name: _____

Title: _____

Date: _____

CARRIER:

By: _____
(Signature)

Name: _____

Title: _____

Date: _____

ACCOUNT INFORMATION SECTION (Items in this section are mandatory)

1. Main Telephone Number: Main line of telephone service that all other numbers are associated to. (Area Code/NXX/Line Numbers)
2. Published Telephone Number: Telephone number to appear in the directory.
3. Old Telephone Number: If the number is changing, enter the OLD Telephone Number.
4. Type of Directory Service: Bus (Business) or Res (Residence)
5. Order Type: N - New connect order; D - Disconnect service order; C - Change of listings; R - Directory delive only.
6. Due Date: Date that service is requested.
7. Carrier Name: The name of the local exchange carrier and operating company code.
8. Carrier Number: Operating Company Number

PRIMARY LISTING INFORMATION SECTION (Items in this section are mandatory)

9. Listed Name: The way the listing is to appear in the directory. (maximum 1,000 characters - including spaces) Caption arrangements should be formatted per guidelines. Non-Pub or Non-List situations should be indicated.
10. Listed Address: Current address may include street number - street name, city, state, and zip code. (Note: P.O. Box or Route not acceptable). Omitted address shown as (OAD). (maximum 250 characters)
11. Service Address: Physical location of the telephone.
12. Community Name: The name of the community where the listing appears. (i.e.: the Atlanta Directory may have a Community name of Buckhead).
13. Zip code: 5 or 9 character code.
14. Yellow Pages Heading: The Yellow Page heading where customer wants his listing to appear. (Valid for Business Primary Listings only).
15. Directory Name: Name of the directory where Customer desires listing to appear (including town section if applicable). If consistent with existing central office and directory configuration, listing will be included. If different, a Foreign Listing will be charged. Directory appearance entitled free is based on the central office prefix. Entitlement for appearance in other directories will be at the rate of a Foreign Listing (FL).

BILLING INFORMATION SECTION (Items in this section are requested but optional)

16. Billing: Name to appear on bill.
17. Billing Address: Street number, street name, city, state, zip.
18. Contact Telephone Number: Telephone number to contact regarding billing.
19. Responsible Person: Owner's name or partners' names or 2 corporate officers.
20. Type of Ownership: Sole owner, Partnership or Corporation
21. Tax ID Number or Social Security Number: If sole owner, must have social security number.

DIRECTORY DELIVERY INFORMATION SECTION (Items in this section are mandatory)

22. Name: Personal or business name.
23. Delivery Address: Street number, street name, city, state, zip code of where directories are to be delivered.
24. Directory (Book ID): Bolt code of the directory.
25. Number of books now: for immediate delivery/replacement.
26. Number of books annually: 0 - 3 residence, 0 - 5 business, then negotiated.

REMARKS SECTION (As required)

27. Remarks: Free flow field used by Carrier for any additional information

PRIVATE/PROPRIETARY

Contains private and/or proprietary information. May not be used or disclosed outside the BellSouth companies except pursuant to a written agreement.

BAPCO Deliverables

Publication Schedules

BAPCO will provide to all carriers a printed copy of the publication schedules for all directories within the area served by the carrier. This schedule will include the name of the directory, the directory bolt code, the business office close date and the issue date. The business office close date represents the last day to receive activity for appearance in the subsequent directory. This date also represents the close date for advertising activity into the Yellow Pages.

The issue date represents the mid-point of delivery of the new directory and the date at which new directory billing will begin for the directory being delivered. The length of the delivery period will vary depending upon the size of directory.

Yellow Pages Headings

BAPCO will provide a printed version of the Yellow Pages Heading file which will include all Yellow Pages heading allowed by BAPCO, the Yellow Pages heading code and the associated SIC code. This material would be utilized to assist the business customer in identifying where they would like representation in BAPCO's classified Yellow Pages directories.

Coverage Maps

BAPCO will provide a coverage map for its major directories identifying broadly the geographic area served by the major directory. These maps will be provided only for the major directories in the area served by the carrier.

Central Office Table

BAPCO will provide two printed versions of what is called the ABC table. Version 1 of this report, identifies by NP/ and in sequence by central office in which directory a customer is entitled to appear. Version 2 of this report reflects the directory name and all central offices appearing within that directory.

Listing Specifications

BAPCO will provide a condensed printed version of listing specifications reflecting the rules and regulations regarding listing appearance in both the white and yellow pages.

Abbreviation Table

BAPCO will provide a printed copy of the standard abbreviations utilized for given names, titles of address, titles of lineage, military titles, degrees and professional affiliations standards. This information can be used to assist in effectively processing various listed name requests.

Foreign Directory Name Table

BAPCO will provide a list of all foreign directory names to be used in the processing of foreign listing requests. This field is a required element in the establishment of foreign listings.

Customer Guide Pages Appearance Procedures

BAPCO will provide free listing appearance under the areas of Establishing Service, Billing and Repair in the Customer Guide Section of the White Pages for directories where a carrier operates. These procedures identify how to get your listing to appear and procedures for purchasing LEC specific pages.

Attachment C-2

Unbundled Products and Services and New Services

Service: Access to Numbers

Description: For that period of time in which BellSouth serves as North American Numbering Plan administrator for the states in the BellSouth region, BellSouth will assist ALECs applying for NXX codes for their use in providing local exchange services.

State(s): All

Rates: No Charge

Attachment C-4

Unbundled Products and Services and New Services

Service: 800 Database

Description: Provides for utilization of the BellSouth 800 Service Control Points for obtaining 800 Service routing information.

800 Database service is provided using a common nationwide 800 Database. The BellSouth network components utilized in the provision of this service are the Service Switching Point (SSP), the Common Channel Signaling Seven Network, the Signal Transfer Point (STP), and the Service Control Point (SCP). Additionally, the Service Management System functions nationally as the central point for the administration of all 800 numbers and downloads 800 number information to BellSouth's SCPs.

ALEC's with STPs will be able to connect directly to BellSouth local or regional STP for obtaining 800 database routing information from BellSouth's SCP and will not be required to order FGD or TSBSA Technical Option 3 Service. For this connection the ALECs may utilize Signaling System Seven Terminations interconnected in Birmingham, AL and Atlanta, GA with BellSouth's local or regional STP.

State(s): All

Rates, Terms and Conditions:

In all states, the 800 Database rates, terms and conditions will be applied as set forth in Sections E2, E5, E6 and E13 of BellSouth Telecommunication's, Inc.'s Intrastate Access Service Tariffs.

Attachment C-7

Unbundled Products and Services and New Services

Service: Signaling

Description: Provides for connection to and utilization of BellSouth's Signaling System 7 network for both call setup and non-call setup purposes.

State(s): All

Rate Elements	Monthly Rate	Recurring Rate	Non-Recurring	Applied Per
CCS7 Signaling Connection - Provides a two-way digital 56 Kbps dedicated facility connecting a customer's signaling point of interface in a LATA to a BellSouth STP. Each customer's connection requires either a pair or a quad of signaling connections.	\$155.00	--	\$510.00	56 Kpbs facility
CCS7 Signaling Termination - Provides a customer dedicated point of interface at the BellSouth STP for each of the customer's SS7 connections.	\$355.00	--	--	STP Port
CCS7 Signaling Usage* - Refers to the messages traversing the BellSouth signaling network for call set-up and non call set-up purposes.	--	\$0.000023 \$0.000050	--	Call Set Up Msg. TCAP Msg.
CCS7 Signaling Usage Surrogate*	\$395.00	--	--	56 Kpbs facility

*Where signaling usage measurement and billing capability exists, CCS7 Signaling Usage will be billed on a per message basis. Where measurement capability does not exist, CCS7 Signaling Usage Surrogate will be billed on a per 56 Kpbs facility basis.

Attachment C-8

Unbundled Products and Services and New Services

Service: Operator Call Processing Access Service

Description: Provides Operator and Automated call handling. This includes processing and verification of alternate billing information for collect, calling card, and billing to a third number. Operator Call Processing Access Service also provides customized call branding; dialing instructions; and other operator assistance the customer may desire.

Rate Elements	State(s)	Monthly Recurring	Applied Per
Operator Provided Call Handling	All	\$1.17	Per Work Minute
Call Completion Access Termination Charge This charge will be applicable per call attempt and is in addition to the Operator Provided Call Handling charge listed above.	Alabama	\$0.06	Per Call Attempt
	Florida	\$0.06	Per Call Attempt
	Georgia	\$0.06	Per Call Attempt
	Kentucky	\$0.06	Per Call Attempt
	Louisiana	\$0.06	Per Call Attempt
	Mississippi	\$0.06	Per Call Attempt
	N.Carolina	\$0.08	Per Call Attempt
	S.Carolina	\$0.08	Per Call Attempt
Tennessee	\$0.12	Per Call Attempt	
Fully Automated Call Handling	All	\$0.15	Per Attempt
Operator Services Transport Operator Services transport rates, terms and conditions are as set forth in E6 of BellSouth Telecommunication's, Inc.'s Intrastate Access Service Tariff.			

Attachment C-9

Unbundled Products and Services and New Services

Service: Directory Assistance Access Service (Number Services)

Description: See below

Rate Elements	Description	State(s)	Monthly Rate
Directory Assistance Call Completion Access Service	Optional service provided to an Access subscriber of BellSouth's DA Access Service. Given a listed telephone number at the request of an Access subscriber's end user, BellSouth will provide or attempt to provide from the DA Operator System, call completion to the number requested. All local and intralata call completion attempts are routed over an intertoll trunk facility directly to the terminating end office that serves the designated number. An Automatic Message Account (AMA) record that includes conversation time, originating, terminating, and billing number details is made for each call completion attempt. This record is in addition to the record made for the DA transaction.	All	\$0.25 (per call attempt)
Call Completion Access Termination Charge	This charge will be applicable per call attempt and is in addition to the DACC Access Service charge listed above.	Alabama Florida Georgia Kentucky Louisiana Mississippi N. Carolina S. Carolina Tennessee	\$0.06 \$0.06 \$0.06 \$0.06 \$0.06 \$0.06 \$0.08 \$0.08 \$0.12
Number Services Intercept Access Service	Number Services Intercept Access refers calls from disconnected numbers to the proper number or numbers. A separate dedicated intercept trunk facility to the Number Services switch for intercept calls is required. Standard trunk signaling is used to send the intercepted number to the Number Services switch and a database hook-up is performed to retrieve the referral number. The referral number is provided to the calling party by a mechanized audio announcement. The subscribing Access customer must provide the updates to the intercept database to support the service.	All	\$0.25 (per intercept query)
Directory Assistance Service Call	Rates, terms and conditions will be applied as set forth in E9.1.7 for Georgia and as set forth in E9.5.3 for AL,FL,KY,LA,MS,NC,SC,TN of BellSouth Telecommunication's Inc.'s Intrastate Access Service Tariff.		
Directory Transport	Rates, terms and conditions will be applied as set forth in E9.1.7 for Georgia and as set forth in E9.5.3 for AL,FL,KY,LA,MS,NC,SC,TN of BellSouth Telecommunication's Inc.'s Intrastate Access Service Tariff.		
Directory Assistance Interconnection	Rates, terms and conditions will be applied as set forth in E9.1.7 for Georgia and as set forth in E9.5.3 for AL,FL,KY,LA,MS,NC,SC,TN of BellSouth Telecommunication's Inc.'s Intrastate Access Service Tariff.		
Directory Assistance Database Service	Rates, terms and conditions will be applied as set forth in A38.1 of BellSouth Telecommunication's Inc.'s General Subscriber Service Tariff.		
Direct Access to DA Service	Rates, terms and conditions will be applied as set forth in Section 9.3 of BellSouth Telecommunication's, Inc.'s Interstate Access Service Tariff F.C.C. No.1.		

Contract Provisions for RAO Hosting and NSPRS

SECTION 1. SCOPE OF AGREEMENT

- 1.01 This Agreement shall apply to the services of Revenue Accounting Office (RAO) Hosting and the Non-Sent Paid Report System (NSPRS) as provided by BellSouth to the ALEC. The terms and conditions for the provisions of these services are outlined in the Exhibits to this Agreement.

SECTION 2. DEFINITIONS

- 2.01 A. Centralized Message Distribution System is the BellCore administered national system, based in Kansas City, Missouri, used to exchange Exchange Message Record (EMR) formatted data among host companies.
- B. Compensation is the amount of money due from BellSouth to the ALEC or from the ALEC to BellSouth for services and/or facilities provided under this Agreement.
- C. Exchange Message Record is the nationally administered standard format for the exchange of data among Exchange Carriers within the telecommunications industry.
- D. Intercompany Settlements (ICS) is the revenue associated with charges billed by a company other than the company in whose service area such charges were incurred. ICS on a national level includes third number and credit card calls. ICS within the BellSouth region includes third number, credit card and collect calls.
- E. Message Distribution is routing determination and subsequent delivery of message data from one company to another. Also included is the interface function with CMDS, where appropriate.
- F. Non-Sent Paid Report System (NSPRS) is the system that calculates ICS amounts due from one company to another in the state of Florida.
- G. Revenue Accounting Office (RAO) Status Company is a local exchange company/alternate local exchange company that has been assigned a unique RAO code. Message data exchanged among RAO status companies is grouped (i.e. packed) according to From/To/Bill RAO combinations.

SECTION 3. RESPONSIBILITIES OF THE PARTIES

- 3.01 RAO Hosting and NSPRS services provided to the ALEC by BellSouth will be in accordance with the methods and practices regularly adopted and applied by BellSouth to its own operations during the term of this Agreement, including such revisions as may be made from time to time by BellSouth.
- 3.02 The ALEC shall furnish all relevant information required by BellSouth for the provision of RAO Hosting and NSPRS.

SECTION 4. COMPENSATION ARRANGEMENTS

- 4.01 Applicable compensation amounts will be billed by BellSouth to the ALEC on a monthly basis in arrears. Amounts due from one party to the other (excluding adjustments) are payable within thirty (30) days of receipt of the billing statement.

SECTION 5. ASSOCIATED EXHIBITS

- 5.01 Listed below are the exhibits associated with this Agreement.

Exhibit A Message Distribution Service (RAO Hosting)
Exhibit B Intercompany Settlements (NSPRS)

- 5.02 From time to time by written agreement of the parties, new Exhibits may be substituted for the attached Exhibits, superseding and canceling the Exhibits then in effect.

SECTION 6. TERM OF AGREEMENT

- 6.01 This agreement is effective _____ and will continue in force until terminated, with or without cause, by thirty (30) days prior notice in writing from either party to the other. This Agreement may be amended from time to time upon written agreement of the parties.

Executed this _____ day of _____, 199_.

WITNESS:

THE ALEC

(title)

WITNESS:

BELLSOUTH TELECOMMUNICATIONS, INC.

(title)

SECTION 1. SCOPE OF EXHIBIT

- 1.01 This exhibit specifies the terms and conditions, including compensation, under which BellSouth shall provide message distribution service to the ALEC. As described herein, message distribution service includes the following:
- 1) Message Forwarding to intraregion LEC/ALEC - function of receiving an ALEC message and forwarding the message to another LEC/ALEC in the BellSouth region.
 - 2) Message Forwarding to CMDS - function of receiving an ALEC message and forwarding that message on the CMDS.
 - 3) Message Forwarding from CMDS - function of receiving a message from CMDS and forwarding that message to the ALEC.

SECTION 2. RESPONSIBILITIES OF THE PARTIES

- 2.01 An ALEC that is CMDS hosted by BellSouth must have its own unique RAO code. Requests for establishment of RAO status where BellSouth is the selected CMDS interfacing host, require written notification from the ALEC to BellSouth at least six (6) weeks prior to the proposed effective date. The proposed effective date will be mutually agreed upon between the parties with consideration given to time necessary for the completion of required BellCore functions. BellSouth will request the assignment of an RAO code from its connecting contractor, currently BellCore, on behalf of the ALEC and will coordinate all associated conversion activities.
- 2.02 BellSouth will receive messages from the ALEC that are to be processed by BellSouth, another LEC/ALEC in the BellSouth region or a LEC outside the BellSouth region.
- 2.03 BellSouth will perform invoice sequence checking, standard EMR format editing and balancing of message data with the EMR trailer record counts on all data received from the ALEC.
- 2.04 All data received from the ALEC that is to be processed or billed by another LEC/ALEC within the BellSouth region will be distributed to that LEC/ALEC in accordance with the agreement(s) which may be in effect between BellSouth and the involved LEC/ALEC.
- 2.05 All data received from the ALEC that is to be placed on the CMDS network for distribution outside the BellSouth region will be handled in accordance with the agreement(s) which may be in effect between BellSouth and its connecting contractor (currently BellCore).
- 2.06 BellSouth will receive messages from the CMDS network that are destined to be processed by the ALEC and will forward them to the ALEC on a daily basis.

- 2.07 Transmission of message data between BellSouth and the ALEC will be via electronic data transmission.
- 2.08 All messages and related data exchanged between BellSouth and the ALEC will be formatted in accordance with accepted industry standards for EMR formatted records and packed between appropriate EMR header and trailer records, also in accordance with accepted industry standards.
- 2.09 The ALEC will ensure that the recorded message detail necessary to recreate files provided to BellSouth will be maintained for back-up purposes for a period of three (3) calendar months beyond the related message dates.
- 2.10 Should it become necessary for the ALEC to send data to BellSouth more than sixty (60) days past the message date(s), that ALEC will notify BellSouth in advance of the transmission of the data. If there will be impacts outside the BellSouth region, BellSouth will work with its connecting contractor and the ALEC to notify all affected parties.
- 2.11 In the event that data to be exchanged between the two parties should become lost or destroyed, both parties will work together to determine the source of the problem. Once the cause of the problem has been jointly determined and the responsible party (BellSouth or the ALEC) identified and agreed to, the company responsible for creating the data (BellSouth or the ALEC) will make every effort to have the affected data restored and retransmitted. If the data cannot be retrieved, the responsible party will be liable to the other party for any resulting lost revenue. Lost revenue may be a combination or revenues that could not be billed to the end users and associated access revenues. Both parties will work together to estimate the revenue amount based upon historical data through a method mutually agreed upon. The resulting estimated revenue loss will be paid by the responsible party to the other party within three (3) calendar months of the date of problem resolution, or as mutually agreed upon by the parties.
- 2.12 Should an error be detected by the EMR format edits performed by BellSouth on data received from the ALEC, the entire pack containing the affected data will not be processed by BellSouth. BellSouth will notify the ALEC of the error condition. The ALEC will correct the error(s) and will resend the entire pack to BellSouth for processing. In the event that an out-of-sequence condition occurs on subsequent packs, the ALEC will resend these packs to BellSouth after the pack containing the error has been successfully reprocessed by BellSouth.
- 2.13 In association with message distribution service, BellSouth will provide the ALEC with associated intercompany settlements reports (national and regional) as appropriate.
- 2.14 In no case shall either party be liable to the other for any direct or consequential damages incurred as a result of the obligations set out in this agreement.

SECTION 3. COMPENSATION

- 3.01 For message distribution service provided by BellSouth for the ALEC, BellSouth shall receive the following as compensation:

Rate Per Message \$0.004

- 3.02 For data transmission associated with message distribution service, BellSouth shall receive the following as compensation:

Rate Per Message \$0.001

- 3.03 Data circuits (private line or dial-up) will be required between BellSouth and the ALEC for the purpose of data transmission. Where a dedicated line is required, the ALEC will be responsible for ordering the circuit, overseeing its installation and coordinating the installation with BellSouth. The ALEC will also be responsible for any charges associated with this line. Equipment required on the BellSouth end to attach the line to the mainframe computer and to transmit successfully ongoing will be negotiated on a case by case basis. Where a dial-up facility is required, dial circuits will be installed in the BellSouth data center by BellSouth and the associated charges assessed to the ALEC. Additionally, all message toll charges associated with the use of the dial circuit by the ALEC will be the responsibility of the ALEC. Associated equipment on the BellSouth end, including a modem, will be negotiated on a case by case basis between the parties.
- 3.04 All equipment, including modems and software, that is required on the ALEC end for the purpose of data transmission will be the responsibility of the ALEC.

SECTION 1. SCOPE OF EXHIBIT

- 1.01 This Exhibit specifies the terms and conditions, including compensation, under which BellSouth and the ALEC will compensate each other for intercompany Settlements (ICS) messages.

SECTION 2. RESPONSIBILITIES OF THE PARTIES

- 2.01 BellSouth will remit to the ALEC the revenue, less a billing charge, for intraLATA ICS messages, Local ICS messages, and charges for other services when related messages and/or services are provided by the ALEC and billed to:
- 1) a BellSouth customer.
 - 2) another company within the BellSouth region (excluding Florida) associated with the exchange of message data with BellSouth (excluding CIID and 891 messages).
 - 3) another company within the conterminous United States that utilizes CMDS directly or indirectly and settles with BellSouth directly or indirectly through the Credit Card and Third Number Settlement System (CATS) administered by BellCore.
 - 4) another company utilizing the non-conterminous RAO codes associated with AT&T's Transport and Tracking Intercompany System settlements with BellSouth.
- 2.02 These other services include, but are not limited to:
- 1) Maritime Mobile Radiotelephone Services radio link charges as set forth in the FCC's Maritime Mobile Radiotelephone Services tariff.
 - 2) Aviation Radiotelephone Service radio link charges as set forth in the FCC's Aviation Radiotelephone Service tariff.
 - 3) Public Land Mobile Radiotelephone Transient-Unit Non-Toll Service charges as approved by the authorized state regulatory commission (or municipal regulatory authority).
 - 4) Non-Toll Service Charges billed to a calling card or to a third number as filed with and approved by the authorized state regulatory commission (or municipal regulatory authority).
 - 5) Directory Assistance Call Charges to a calling card or to a third number as approved by the authorized regulatory commission.

- 2.03 The ALEC will bill, collect and remit to BellSouth the charges for intraLATA and/or local ICS messages and other services as described above where such messages and/or services are provided by:
- 1) BellSouth,
 - 2) another company within the BellSouth region (excluding Florida) associated with the exchange of message data with BellSouth (excluding CIID and 891 messages),
 - 3) another company within the conterminous United States that utilizes CMDS directly or indirectly and settles with BellSouth directly or indirectly through the Credit Card and Third Number Settlement System (CATS).
- 2.04 For ICS revenues involving the ALEC and other non-BellSouth LECs/ALECs within the state, BellSouth will provide the ALEC with monthly reports summarizing the ICS revenues for messages that originated with the ALEC and were billed by each of the other Florida LECs/ALECs and those messages that originated with each of the other Florida LECs/ALECs and were billed by the ALEC.

SECTION 3. COMPENSATION

- 3.01 The following compensation shall be retained by the billing company for the billing of ICS messages and services:

	<u>Rate Per Message</u>
1) Calls originated and billed in Florida or originated and billed in North Carolina	\$0.0666
Calls originated in any of the states within BellSouth region and billed in that same state	\$0.05
2) Calls originated in a state within BellSouth's region and billed in another state or originated in another state and billed in a state within BellSouth's region	\$0.05
3) Calls originated in a state within BellSouth's region and billed outside the conterminous United States	\$0.16

Attachment C-13

Unbundled Products and Services and New Services

Service: Virtual Collocation

Description: Virtual Expanded Interconnection Service (VEIS) provides for location interconnection in collocator-provided/BellSouth leased fiber optic facilities to BellSouth's switched and special access services, and local interconnection facilities.

Rates, Terms and Conditions:

State(s): All except Florida: In all states except Florida, the rates, terms and conditions will be applied as set forth in Section 20 of BellSouth Telecommunication's, Inc. Interstate Access Service Tariff, FCC No. 1.

State: Florida In the state of Florida, the rates, terms and conditions will be applied as set forth in Section E20 of BellSouth Telecommunication's, Inc. Intrastate Access Service Tariff.

Service: Physical Collocation

Description: Per FCC - (10/19/92 FCC Order, para 39)
Physical Collocation is whereby "the interconnection party pays for LEC central office space in which to locate the equipment necessary to terminate its transmission links, and has physical access to the LEC central office to install, maintain, and repair this equipment."

State(s): All

Rates, Terms and Conditions: To be negotiated

BellSouth Telecommunications

Negotiations Handbook

for

Collocation

Table of Contents

	Page
<u>General</u>	
Preface.....	3
Introduction.....	3
Service Description.....	4
Rate Components.....	5
 <u>General Terms and Conditions</u>	
Application for service.....	8
Assignment of space.....	8
Occupancy of space.....	8
Pricing structure.....	8
 Equipment installation.....	 9
Alarm and monitoring.....	9
Inspections.....	9
Commencement Date.....	9
 Insurance Requirements.....	 10
Ordering Interconnected service.....	10
Assignment of facilities.....	10
Liability.....	10
 Access to BellSouth C.O.'s.....	 11
Recovery of extraneous expenses.....	11
Cancellation of a request.....	11
Conversion of Virtual to Physical collocation.....	11
Special Reports.....	11
 <u>Contacts</u>	
Negotiation contacts.....	12
Obtaining an Application Form.....	12
 <u>Appendix</u>	
BellSouth Certified Vendor list.....	13
Central Office Exemption list for Physical Collocation.....	14
Schematic drawings.....	15
Rates.....	17
Zone A Offices.....	18

Preface

This handbook describes BellSouth's Collocation offerings and contains general information regarding the terms and conditions, ordering, provisioning and maintenance of BellSouth's Physical Collocation offering. By design, this document does not contain detailed descriptions of network interface qualities, network capabilities, local interconnection or product service offerings. This document does not represent a binding agreement in whole or in part between BellSouth and subscribers of BellSouth's Collocation services.

Based on the nature of your business, you will find a list of contacts included for your convenience in discussing the above items.

Introduction

BellSouth offers Virtual Expanded Interconnection from the FCC #1 tariff and from the Florida State Access E tariff for the interconnection to Access services. BellSouth will negotiate Physical Collocation on a first come, first serve basis, depending on space availability for interconnection to unbundled network elements, access services and state tariff services required for use by telecommunications service providers.

Service Description

Virtual Expanded Interconnection Service (VEIS)

VEIS is a tariffed offering which provides for the placement of collocator-owned facilities and equipment in BellSouth Central Offices and the interconnection of this equipment to BellSouth Switched and Special Access Services. Equipment that is part of a VEIS arrangement is most commonly located in the BST equipment line-up.

With VEIS, the collocator places fiber optic cable outside the central office to a designated interconnection point, such as a manhole. The collocator will provide the entrance fiber between the interconnection point and the collocation equipment arrangement inside the central office, cabling from the arrangement to the BST cross-connect point, and cabling from the arrangement to the BST provided power source. BellSouth will lease the entrance fiber, cabling and equipment placed by the collocator for the nominal fee of one dollar.

Alarming and monitoring of the collocated equipment is the responsibility of the collocator. BellSouth will perform all maintenance and repair on collocator equipment once notified by the collocator that such work is necessary. For additional information regarding BellSouth's Virtual Expanded Interconnection Service, please reference Section 20 of BellSouth's FCC #1 tariff or section 20 of BellSouth's Florida Dedicated Access Tariff.

Physical Collocation

By definition, Physical Collocation goes beyond the arrangement described above. Physical Collocation offers leased Central Office space for either Expanded Interconnection (EIS) or for Service Interconnection (SI). Expanded Interconnection is the placement of private entrance facilities and equipment owned by third parties, interconnected to BellSouth's tariffed services. Service Interconnection allows for the placement of equipment owned by third parties, interconnected to BellSouth tariff services, without private entrance facilities.

Unlike VEIS, the equipment placed as part of a Physical Collocation arrangement will be placed in floor space separated from BST equipment by common fire wall protection and will be fully owned, maintained, and repaired by the collocator or their approved agent. The equipment compliment may include transmission equipment, switching equipment, routers, PCs and modems.

As with VEIS, all equipment placed as part of a collocation arrangement must be installed by a BellSouth certified vendor and must meet NEBS standards. A steel gauge cage may be purchased from BellSouth to house the equipment arrangement at the request of the collocator for an additional fee.

Rate Components

The rate element components of Virtual Collocation are contained in BellSouth's FCC #1 tariff, Section 20 and in the Florida Dedicated Services tariff, Section 20. Physical collocation offers a menu-style ordering provision so you may select only the items required for your individual arrangement(s). Some components are required for all physical collocation arrangements and will be marked by an (R) next to the item in the descriptions following.

Application fee (R)

The application fee is required for all collocators to cover the engineering and administrative expense associated with your application inquiry. This fee is a one time charge per request, per C.O. for each new VEIS / EIS / IS service request. No application fee is required for updates, amendments or supplements to service requests in progress. A subsequent request by the same customer in the same C.O. will be treated as "new" if the initial VEIS / EIS / IS request has completed and is in service. The Application fee must be paid upon submission of an application to indicate a bona fide request.

Floor Space (R)

This component covers the square footage for the equipment rack(s) and POT bay for your arrangement plus a factor of 50% when no cage is present, or will include the enclosure square footage when a cage is utilized. When a cage is not requested, square footage will be calculated based on the shadow print of your equipment racks and POT bay times the factor of 1.50 to compensate for maintenance walk-around space for your equipment. If you require administrative space for your arrangement, i.e. a desk or terminal stand, you will be required to purchase a cage enclosure.

The floor space charge also covers lighting, heat, air conditioning, ventilation and other allocated expenses associated with the central office building and will commence billing the day the allocated space is turned over to the collocator for occupancy. The floor space element does not include the amperage required to power the collocated equipment.

Power (R)

The amps required to power the collocated equipment will be charged per ampere based on equipment manufacturers specifications for maximum power requirement.

Cross-connect (R)

This element provides the one-for-one interconnection to BellSouth's tariffed Switched and Special Access service offerings (i.e. DS0, DS1 or DS3 services) or Unbundled service elements (voice grade 2-wire or 4-wire unbundled loop, port). It is a flat rate, non-distance sensitive charge and will be applied on a per circuit order basis.

Rate Components (cont.)

POT bay (R)

BellSouth requires the use of a Point of Termination Bay (POT bay) for demarcation with physical collocation. Although this is currently a separate rate element, the charge for each termination on the POT bay will be rolled into the cross-connect rate element in the near future.

Cable Installation

The cable installation charge applies only to collocators who provide private entrance facilities to their collocated equipment. This is a one time (non-recurring) charge per cable, per installation to arrange the punch through to the manhole, pull fiber cable length from the serving manhole to the Central Office cable vault, perform splicing to collocator provided fire retardant riser, and pull cable length through cable support structure to the collocation arrangement location.

Cable Support Structure

The component covers the use and maintenance of the Central Office duct, riser and overhead racking structure when the collocator has elected to provide private entrance to their equipment. This is a nominal, monthly recurring charge.

Space Preparation fee

This one time fee per arrangement, per location covers the survey, engineering, design, and building modifications for the shared physical collocation area within a central office. BellSouth will pro rate the total space preparation costs among all collocators at that location based on the number of square footage requested. This charge may vary dependent on the location and the type of arrangement requested. The Space preparation charge is payable in full before cage construction or equipment installation begins.

Space construction fee

This element applies to physical collocation arrangements only and will vary based on the type of arrangement requested. The fee covers the materials and installation of optional steel gauge caging, C.O. grounding, fluorescent lighting, floor treatment, power outlet, extension of environmental alarms and other incremental materials cost charged on a per square foot basis.

Security Escort (R)

A security escort will be required for all equipment inspections under VEIS and for maintenance, repair or provisioning visits by a collocator or their agent under physical collocation for some central offices based on office configuration. The charge is based on half hour increments.

Rate Components (cont.)

Additional Engineering

This charge may apply for modifications to an application in progress which results in architectural, design or engineering changes. The charge may also apply to incidental engineering and design for physical collocation space when a full space construction charge does not apply.

Administrative reporting

Collocators who request administrative reports will be assessed a report fee on a per occurrence basis.

General Terms and Conditions

Application for service

The application for collocation is a two-phased process consisting of an Application Inquiry and a Firm Order. To obtain a copy of BellSouth's application form, see page 10 of this document. Prior to negotiations for equipment placement, the inquiry document must be submitted for review and planning by the Central Office equipment engineers, space planners and facility planners. Based on the feedback from these sources, BellSouth will respond to the application in writing.

Following the collocater's review of BellSouth's response, a Firm Order may be submitted for each location for which the collocater wishes to proceed. The Firm Order may be submitted on the same form used during the Inquiry phase, provided all necessary revisions are clearly marked to indicate the applicant's finalized plans. A detailed equipment drawing must accompany the Firm Order Request. The application fee referenced in the previous section must also accompany each application as an indication of a bona fide request.

Assignment of space

BellSouth will assign space for collocation based on space availability and on a first come, first serve basis. For physical collocation, a customer may opt for a cage enclosure which will be offered as a 100 square foot minimum based on space availability within the area designated for physical collocation.

A collocater requesting more than a 100 square foot cage module will be offered contiguous space where available. Where contiguous space is unavailable, the collocater may elect the construction of two separate enclosures and may interconnect its arrangements one to another.

If BellSouth determines there is insufficient space within a central office to accommodate physical collocation, BellSouth will provide Virtual Expanded Interconnection in accordance with existing regulatory requirements.

Pricing structure

BellSouth offers a pricing plan which meets the specifications of the 1996 Legislative Act. The plan features zone and location based pricing, some recurring elements and offers the optional purchase of a caged enclosure.

Occupancy of space

The collocater must commence equipment installation within 180 days from the date space is made available by BellSouth or forfeit the right to use the space.

General Terms and Conditions (cont.)

Equipment installation

The collocator must select an equipment installation vendor who has achieved BellSouth Certified Vendor status to perform all engineering and installation work associated with the equipment collocation arrangement. This ensures BellSouth's standards for safety and quality will be met. A list of certified vendors is contained in the Appendix of this document.

The Certified Vendor is responsible for installing the collocation equipment and components, running power feed(s) to the BellSouth BDFB, performing operational tests after the equipment installation is completed, and notifying the local BellSouth Equipment Engineer and the Collocator upon successful completion of the installation and acceptance testing. Arrangements must be made such that the Collocator is billed directly by the Certified Vendor for activities associated with the arrangement installation. A list of certified vendors may be obtained from the Collocation contact found on page 10 of this Handbook.

Alarm and monitoring

The collocator is responsible for the placement and monitoring of their own remote equipment, environmental, power alarms. BellSouth will place environmental alarms in collocation areas for its own use and protection. Upon request, BellSouth will provide remote monitoring circuits at the tariff rate for the service requested.

Inspections

BellSouth will conduct an inspection of the collocator's equipment and facilities between the time of the initial turn-over of the space and the activation of cross-connect elements. Subsequent inspections may occur with equipment additions or on a predetermined interval basis. For such inspections, BellSouth will provide a minimum of 48 hours advance notification. BellSouth reserves the right to conduct inspections without prior notification to ensure compliance to the terms and conditions of the tariff or agreement. Collocator personnel have the right to be present for inspections.

A collocator may inspect their virtual collocation arrangement upon completion of the arrangement installation. A security escort will be required. Any additional inspections must be coordinated with BellSouth and will also require a security escort.

Commencement Date

The date which the collocator and BellSouth jointly certify the interconnector's equipment is operational and is connected to BellSouth's will be the commencement date.

General Terms and Conditions (cont.)

Insurance

BellSouth will require the following coverages: (1) \$15 million in comprehensive general liability insurance or a combination of commercial general liability and excess umbrella coverage totalling \$15 million; (2) workers compensation coverage/employers liability coverage with limits not less than \$100,000 each accident; (3) \$100,00 each employee by disease, \$500,000 policy limit by disease. BellSouth will review requests for self insurance on a case by case basis.

Insurance coverage must be in effect on or before the date of occupancy (equipment delivery) and must remain in effect until departure of all collocator personnel and property from the central office.

Ordering Interconnected service

A collocator may interconnect to special and switched access services from BellSouth's FCC #1 at the DS3, DS1 and equivalent DS0 cross-connect level. Interconnection is also available to Unbundled loops and ports from the State Access E tariff / State Dedicated Services E tariff for certified ALECs only. Please ask your BellSouth contact for state specific information.

Services to be interconnected to a collocation arrangement must be submitted on Access Service Request (ASR) forms using industry standards and code sets for accurate and complete requests. For information regarding the ASR ordering process and field definitions, please reference the Access Service Ordering Guide, BellCore's Special Reports SR STS-471001 and 471004.

Assignment of facilities

When a customer orders a service which interfaces at an end customer location at the same level as the cross-connect purchased, BellSouth will assign facilities within its network and provide the interconnection information on the Design Layout Record (DLR). When a customer orders cross-connects at a higher interface level than the service purchased for the end customer, the ordering customer must provide BellSouth with the circuit facility assignment.

Liability

The collocator is responsible and accountable for the actions of their employees and their agents. The collocator will be required to pay liquidated damages to BST for damage to BST property, equipment or facilities as a result of the actions or behaviors of either the collocator employees or their agents.

General Terms and Conditions (cont.)

Access to BellSouth Central Offices

Only BellSouth employees, BellSouth certified vendors, Collocator employees and their authorized agents are permitted in BellSouth Central office buildings. All collocators are required to provide their employees and authorized agents a picture identification. This identification must have the employee name and company name clearly printed and must be visible at all times while the individual is inside a BellSouth facility. Manned offices will afford 24 hour, 7 day per week access without prior arrangements. Unmanned offices may require prior arrangement for the dispatch of a BellSouth employee or security escort for building access.

Recovery of extraneous expenses

Should BellSouth discover, upon beginning construction for physical collocation space, that unexpected major renovation or upgrade will be required to one of the following in order to facilitate physical collocation, BST will share the costs of these expenses among collocators based on the number of square footage being requested: ground plane addition, asbestos abatement, mechanical upgrade, major HVAC upgrade, separate egress, ADA compliance.

Cancellation of a request in progress

If a collocator cancels an in-progress firm order request, the collocator will be responsible for reimbursing BST for expenses incurred to date. If the collocator has prepaid all or a portion of the non-recurring fees, BellSouth will refund the amount not expended as of the date of the cancellation.

Conversion of Virtual to Physical Collocation

Collocators who have existing VEIS arrangements may convert these arrangements to physical collocation provided the terms and conditions for physical collocation are met. The collocator will be responsible for the payment of BellSouth fees associated with physical collocation, rearrangement of existing services and vendor costs for the relocation of equipment.

Special Reports

BellSouth will negotiate with requesting parties in the development of administrative reports, based on the availability of the data being requested. A fee structure will be based on the complexity of the request and resources required to produce the report(s).

Negotiation Contacts

For ALEC initial contact:

<u>Contact Name</u>	<u>Telephone</u>
Jerry Hendrix	404 529-8833

For all IXC, CAP, and subsequent ALEC contacts:

<u>Contact Name</u>	<u>Telephone</u>	<u>Pager Number</u>	<u>Fax Number</u>
Nancy Nelson	205 977-1136	1-800-729-1380	205 977-0037
Gretchen Temple	205 977-1122	1-800-655-2205	"

Or contact your Account Representative

For * BBS End User Customers * Third Party Agents * Solutions Providers

General information:

<u>Contact Name</u>	<u>Telephone</u>	<u>Fax Number</u>
Tony Saberre	205 985-6195	205 985-1900

Or contact your account representative.

To obtain a copy of BellSouth's Application / Inquiry document:

**Contact: Nancy Nelson
(205) 977-1136
Room E4E1 South
3535 Colonnade Drive
Birmingham, Alabama**

SAMPLE:
Physical Collocation
BellSouth Certified Vendor List
For Engineering and Installation of Collocation Arrangements

<u>Company Name</u>	<u>Contact Name</u>		<u>Telephone</u>
ADC Communications	Ken Reeves		800 223-9773
	Doug Guidry		318 684-2860
Alcatel	Ed Boatwright	FL	404 270-8335
	Alex Baber	FL	800 869-4869
E F & I Services Co.	Reed Tillis		904 355-7930
Lucent Technologies, Inc.	Jerry Jones	KY	502 429-1346
	Mike Harrington	MS	601 544-7530
	George Ferguson	MS	601 949-8275
	James McGarity	GA	404 573-4120
	Janet Hallford	GA	404 573-6945
	Charlotte office	NC	704 596-0092
	Charlotte office	NC	704 598-0750
	Other areas	NC	910 299-0326
	Adrian Dye	SC	803 926-5213
	Alabama office	AL	205 265-1291
Intel	Richard Becht		800 875-6468
			404 923-0304
North Supply / DA TEL FiberNet, Inc.	Terry Fowler		800 755-0565
	Doug Sykes		205 942-4411
Quality Telecommunications, Inc.	Jerry Miller		770 953-1410
Rapid Response Communications	Ted Pellaux		615 546-2886
Six "R" Communications, Inc. (<u>NC and SC only</u>)	Ken Koontz		704 535-7607
	Dick Phillips		704 289-5522
Tele-Tech Company	Karl Bush	KY	606 275-7505
	Bob Burch		606 275-7502
W.E. Tech, Inc.	Wes Evans		305 587-6996

BellSouth Physical Collocation
 Central Office Exemptions
 (through September 1994)*

<u>State</u>	<u>City</u>	<u>Central Office</u>	<u>CLLI</u>
Alabama	Birmingham	Five Points South Main and Toll Riverchase	BRHMALFS BRHMALMT BRHMALRC
	Huntsville	Redstone Arsenal	HNVLALMA
Florida	Chipley	Jackson	CHPLFLJA
	Gainesville	Main	GSVLFLMA
	Jacksonville	Mandarin Avenues	MNDRFLAV
		San Jose	JCVLFLSJ
		South Point (JT Butler)	JCVLFLJT
	Jupiter	Main	JPTRFLMA
	Lake Mary	Main (Heathrow)	LKMRFLMA
	Lynn Haven	Ohio Avenue	LYHNFLOH
	North Dade	Golden Glades	NDADFLGG
	Pensacola	Ferry Pass	PNSCFLFP
West Palm Beach	Gardens Royal Palm	WPBHFLGR WPBHFLRP	
Georgia	Austell	Main	ASTLGAMA
	Tucker	Main	TUKRGAMA
Kentucky	Louisville	Armory Place	LSVLKYAP
		Bardstown Road	LSVLKYBR
		Westport Road	LSVLKYWE
Paducah	Main	PDCHKYMA	
North Carolina	Charlotte	Reid Road	CHRLNCRE
		Research Drive (Univ.)	CHRLNCUN
	Greensboro Pembroke	Airport Central	GNBONCAP PMBRNCCE
South Carolina	Columbia	Senate Street	CLMASCSN
	Greenville	Woodruff Road	GNVLSCLR
Tennessee	Memphis	Main Midtown Southside	MMPHTNMA MMPHTNMT MMPHTNST

* BellSouth ceased qualifying C.O.'s September 1994 due to elimination of physical offering.

Physical Co-location: Expanded Interconnection

With Expanded Interconnection, the co-locator is "expanding" their private network to interconnect with BellSouth's network. Therefore, private fiber is placed to the central office and pulled through to the co-location arrangement. The co-locator places their equipment in leased floor space and purchases cross-connects to BellSouth's transport services.

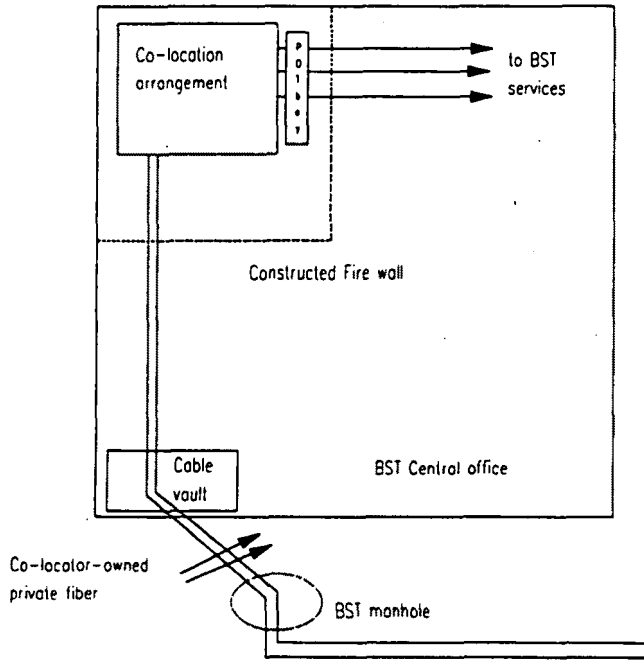

Elements	Type of charge
Application fee	NRC
Space preparation fee	NRC
Space construction fee *	NRC
Cable installation fee	NRC
Cable support structure	RC
Floor space / per square foot includes environmentals	RC
Floor space - power / per ampere	RC
Cross-connects	RC
Security escort / per 1/2 hour	(as required)

* Applies for optional cage construction only

Physical co-location: Service Interconnection arrangement

With a Service Interconnection arrangement, the co-locator places their equipment in leased floor space and purchases cross-connects to BellSouth's Transport services. For this arrangement, BellSouth will request a minimum 24 month contract for both the floor space and transport services, as well as a minimum number of interconnected DS1 or DS3 services.

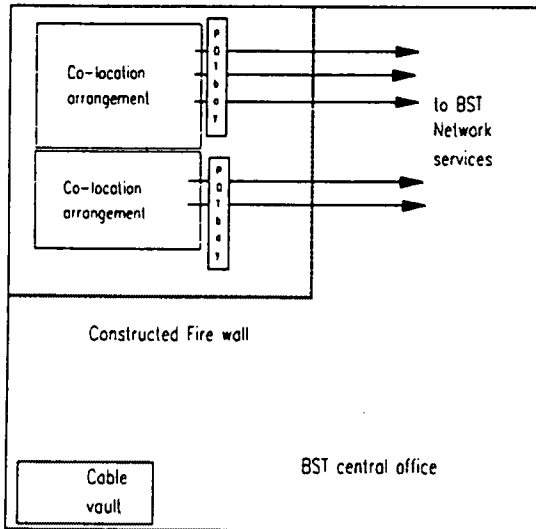

Elements	Type of charge
Application fee	NRC
Space preparation fee	NRC
Space construction fee *	NRC
Floor space / per square foot includes environmentals	RC
Floor space - power / per ampere	RC
Cross-connects	RC
Security escort / per 1/2 hour	(as required)

* Required only for optional cage construction

Rates for Negotiated Interconnection

Rate Element	Application/Description	Type of charge	Rate
Application Fee	Applies per arrangement per location	Non recurring	\$ 3,850.00
Space Preparation Fee	Applies for survey and design of space, covers shared building modification costs	Non recurring	ICB *(1) Will not be less than \$1,788.00
Space Construction Fee	Covers materials and construction of optional cage in 100 square foot increments	Non recurring	\$ 8,500.00 *(2) first 100 sq ft \$ 4,500.00 adtl 100 sq ft
Cable Installation Fee	Applies per entrance cable	Non recurring	\$ 3,650.00
Floor Space	Per square foot, for Zone A and Zone B offices respectively	Monthly Recurring	\$9.30 / \$8.40*(3)
Power	Per ampere based on manufacturer's specifications	Monthly Recurring	\$ 5.15 per ampere
Cable Support Structure	Applies per entrance cable	Monthly Recurring	\$13.35 per cable
POT bay	Optional Point of Termination bay; per 2-wire / 4-wire and per DS1 / DS3 cross-connect respectively	Monthly Recurring	\$.40 / \$1.20 \$1.20 / \$5.00 *(4)
Cross-connects	Per 2-wire / 4-wire respectively	Monthly Rec Non-recurring	\$ 1.10 / \$ 1.60 \$155.00 / \$155.00
	Per DS1 / DS3 respectively	Monthly Rec. Non-recurring	\$ 9.28 / \$ 72.48 \$155.00 / \$155.00
Security escort	First and additional half hour increments, per tariff rate in Basic time (B), Overtime (O) and Premium time (P).	As required This is a tariffed charge.	\$41.00 / \$25.00 B \$48.00 / \$30.00 O \$55.00 / \$35.00 P

Note 1: Will be determined at the time of the application based on building and space modification requirements for shared space at the requested C.O.

Note 2: Applies only to collocators who wish to purchase a steel-gauge cage enclosure.

Note 3: See attached list for zone A offices as of November 1996. This list is subject to amendment.

Note 4: Will be combined with cross-connect charge as one element in the near future.

Attachment C-15

Unbundled Products and Services and New Services

Service: Unbundled Exchange Access Loop

Description: Provides the connection from the serving central office to a subscriber's premises. It is engineered to meet the same parameters as a residence or business exchange access line.

Information relative to multiplexing of the Unbundled Exchange Access Loop is described in Attachment C-16 following.

State(s):	Alabama			Florida			Georgia		
	Monthly	Nonrecurring First	Charges Add'l	Monthly	Nonrecurring First	Charges Add'l	Monthly	Nonrecurring First	Charges Add'l
Unbundled Exchange Access Loop	\$25.00	\$140.00	\$45.00	\$17.00	\$140.00	\$45.00	\$25.00	\$140.00	\$45.00
Unbundled Exchange Access IOC									
- Fixed	\$30.00	\$97.00	N/A	\$28.50	\$87.00	N/A	\$32.00	\$105.00	N/A
- 1 - 8 Miles	\$2.05	N/A	N/A	\$1.65	N/A	N/A	\$2.05	N/A	N/A
- 9 - 25 Miles	\$2.00	N/A	N/A	\$1.60	N/A	N/A	\$2.00	N/A	N/A
- Over 25 Miles	\$1.95	N/A	N/A	\$1.55	N/A	N/A	\$1.95	N/A	N/A

State(s):	Kentucky			Louisiana			Mississippi		
	Monthly	Nonrecurring First	Charges Add'l	Monthly	Nonrecurring First	Charges Add'l	Monthly	Nonrecurring First	Charges Add'l
Unbundled Exchange Access Loop	\$25.00	\$140.00	\$45.00	\$25.00	\$140.00	\$45.00	\$25.00	\$140.00	\$45.00
Unbundled Exchange Access IOC									
- Fixed	\$30.00	\$93.00	N/A	\$30.00	\$100.00	N/A	\$30.00	\$96.00	N/A
- 1 - 8 Miles	\$2.05	N/A	N/A	\$2.05	N/A	N/A	\$2.05	N/A	N/A
- 9 - 25 Miles	\$2.00	N/A	N/A	\$2.00	N/A	N/A	\$2.00	N/A	N/A
- Over 25 Miles	\$1.95	N/A	N/A	\$1.95	N/A	N/A	\$1.95	N/A	N/A

State(s):	N.Carolina			S.Carolina			Tennessee		
	Monthly	Nonrecurring First	Charges Add'l	Monthly	Nonrecurring First	Charges Add'l	Monthly	Nonrecurring First	Charges Add'l
Unbundled Exchange Access Loop	\$30.03	\$140.00	\$45.00	\$25.00	\$140.00	\$45.00	\$25.00	\$140.00	\$45.00
Unbundled Exchange Access IOC									
- Fixed	\$11.85	\$71.87	N/A	\$50.00	\$97.00	N/A	\$30.00	\$96.00	N/A
- 1 - 8 Miles	\$2.15	N/A	N/A	\$2.05	N/A	N/A	\$2.05	N/A	N/A
- 9 - 25 Miles	\$2.15	N/A	N/A	\$2.00	N/A	N/A	\$2.00	N/A	N/A
- Over 25 Miles	\$2.15	N/A	N/A	\$1.95	N/A	N/A	\$1.95	N/A	N/A

Attachment C-16

Unbundled Products and Services and New Services

Service: Channelization System for Unbundled Exchange Access Loops

Description: This new rate element provides the multiplexing function for Unbundled Exchange Access Loops. It can convert up to 96 voice grade loops to DS1 level for connection with the ALEC's point of interface. The multiplexing can be done on a concentrated basis (delivers at 2 DS1 level to customer premise) or on a non-concentrated basis (delivers at 4 DS1 level to customer premise) at the option of the customer.

In addition to the following rate elements, 1.544 Mbps local channel and/or interoffice channel facilities may be required as set forth in E7 of BellSouth Telecommunication's, Inc.'s Intrastate Access Service Tariff for non-collocated ALECs.

State(s)	Alabama			Florida			Georgia		
Rate Elements	Monthly Rate	Nonrecurring Charge First	Charge Add'l	Monthly Rate	Nonrecurring Charge First	Charge Add'l	Monthly Rate	Nonrecurring Charge First	Charge Add'l
Unbundled Loop Channelization System (DS1 to VG), Per System	\$575.00	\$525.00	N/A	\$555.00	\$490.00	N/A	\$555.00	\$490.00	N/A
Central Office Channel Interface (circuit specific plug-in equipment), 1 per circuit	\$1.70	\$8.00	\$8.00	\$1.70	\$7.00	\$7.00	\$1.70	\$7.00	\$7.00

State(s)	Kentucky			Louisiana			Mississippi		
Rate Elements	Monthly Rate	Nonrecurring Charge First	Charge Add'l	Monthly Rate	Nonrecurring Charge First	Charge Add'l	Monthly Rate	Nonrecurring Charge First	Charge Add'l
Unbundled Loop Channelization System (DS1 to VG), Per System	\$540.00	\$495.00	N/A	\$530.00	\$510.00	N/A	\$560.00	\$450.00	N/A
Central Office Channel Interface (circuit specific plug-in equipment), 1 per circuit	\$1.60	\$8.00	\$8.00	\$1.60	\$8.00	\$8.00	\$1.70	\$6.00	\$6.00

State(s)	N.Carolina			S.Carolina			Tennessee		
Rate Elements	Monthly Rate	Nonrecurring Charge First	Charge Add'l	Monthly Rate	Nonrecurring Charge First	Charge Add'l	Monthly Rate	Nonrecurring Charge First	Charge Add'l
Unbundled Loop Channelization System (DS1 to VG), Per System	\$545.00	\$475.00	N/A	\$520.00	\$480.00	N/A	\$530.00	\$520.00	N/A
Central Office Channel Interface (circuit specific plug-in equipment), 1 per circuit	\$1.65	\$7.00	\$7.00	\$1.60	\$6.00	\$6.00	\$1.60	\$8.00	\$8.00

Attachment C-17

Unbundled Products and Services and New Services

Service: Unbundled Exchange Ports

Description: An exchange port is the capability derived from the central office switch hardware and software required to permit end users to transmit or receive information over BellSouth's public switched network. It provides service enabling and network features and functionality such as translations, a telephone number, switching, announcements, supervision and touch-tone capability.

In addition, a BellSouth provided port with outgoing network access also provides access to other services such as operator services, long distance service, etc. It may also be combined with other services available in BellSouth's Intrastate Access Service Tariffs as technically feasible.

When an Unbundled Port is connected to BellSouth provided collocated loops, cross-connection rate elements are required as set forth in Section 20 of BellSouth Telecommunications's, Inc.'s Interstate Access Tariff, FCC No.1.

Alabama			Florida		Georgia	
Rate Elements	Rate	Per	Rate Elements	Rate	Rate Elements	Rate
Monthly (1)			Monthly		Monthly	
Residence Port	\$2.50		Residence Port	\$2.00	Residence Port	\$2.28
Business Port	\$7.00		Business Port	\$4.50	Business Port	\$4.60
PBX Trunk Port (2,3,4)	\$7.00		PBX Trunk Port	\$7.50	PBX Trunk Port	\$7.37
Rotary Service	\$2.00		Rotary Service	\$2.00	Rotary Service	\$2.77
Primary Rate ISDN NAS (5,6)	\$20.00					
Usage-Mileage Bands			Usage-(STS)		Usage-(STS)	
A (0 miles)	\$0.02	Init.min.	- init. min.	\$0.0275	-setup per call	\$0.02
B (1-10 miles)	\$0.04	Init.min.	- add'l min.	\$0.0125	- per minute or fraction thereof	\$0.02
C (11-16 miles)	\$0.02	Add'l min.				
D (17-22 miles & existing LCA described in A3.6 greater than 22 ml.)	\$0.06	Init.min.				
E (23-30 miles)	\$0.04	Add'l min.				
F (31-40 miles)	\$0.10	Init.min.				
G (Special Band) (7)	\$0.10	Add'l min.				

NOTES:

- (1) Nonrecurring Charges, as displayed in Table I on Page 3, and Usage Charges, as displayed on this page, apply in addition to monthly rates.
- (2) Applies per outgoing, incoming or 2-way trunk port.
- (3) DID requires rates and charges as indicated in Table II on Page 3 in addition to the PBX Trunk Port rates.
- (4) IOD requires rates and charges as indicated in Table III on Page 3 in addition to the PBX Trunk Port rates.
- (5) Applies per outgoing, incoming or 2-way voice grade equivalent.
- (6) Primary rate ISDN requires a primary rate interface in addition to the primary rate ISDN NASEs. Additional charges also apply per Primary Rate B-Channel, Call-by-Call Integrated Service Access Service Selection and Incoming Call Identification. See Table IV on Page 3 for rates and charges.
- (7) In addition to the local calling described in A3 of BellSouth's General Subscriber Service Tariff, if any wire center in an exchange is located within 40 miles of any wire center in the originating exchange, local calling will be provided from the entire originating exchange to the entire terminating exchange. The usage charges for Band G are applicable for distances greater than 40 miles.

Attachment C-17

Unbundled Products and Services and New Services

Service: Unbundled Exchange Ports (Cont'd)

Kentucky			Louisiana		
Rate Elements	Rate	Per	Rate Elements	Rate	Per
Monthly			Monthly		
Residence Port	\$3.50		Residence Port	\$2.50	
Business Port	\$10.00		Business Port	\$7.00	
PBX Trunk Port	\$10.00		PBX Trunk Port	\$7.00	
Rotary Service	\$3.50		Rotary Service	\$3.50	
Usage-Mileage Bands			Usage-Mileage Bands		
A (0 miles)	\$0.04	Init.Min.	O (0 miles)	\$0.02	Init.Min.
	\$0.02	Add'l min.		\$0.01	Add'l min.
B (1-10 miles)	\$0.04	Init.Min.	A (1-10 miles)	\$0.04	Init.Min.
	\$0.02	Add'l min.		\$0.02	Add'l min.
C (Greater than 10 miles Limited LCA)	\$0.06	Init.Min.	B (11-16 miles)	\$0.06	Init.Min.
	\$0.04	Add'l min.		\$0.04	Add'l min.
D (1-10 miles beyond Limited LCA)	\$0.04	Init.Min.	C (17-22 miles)	\$0.10	Init.Min.
	\$0.02	Add'l min.		\$0.07	Add'l min.
E (11-16 miles beyond Limited LCA)	\$0.06	Init.Min.	D (23 - 30 miles Basic LCA and Intra Parish Expanded LCA)	\$0.14	Init.Min.
	\$0.04	Add'l min.		\$0.10	Add'l min.
F (17-22 miles beyond Limited LCA)	\$0.09	Init.Min.	E (Greater than 30 miles Basic LCA and Intra Parish Expanded LCA)	\$0.14	Init.Min.
	\$0.07	Add'l min.		\$0.14	Add'l min.
G (23-30 miles beyond Limited LCA)	\$0.09	Init.Min.	F (23 - 30 miles Inter-Parish Expanded LCA)	\$0.14	Init.Min.
	\$0.07	Add'l min.		\$0.10	Add'l min.
H (31-40 miles beyond Limited LCA)	\$0.09	Init.Min.	G (31 - 40 miles Inter-Parish Expanded LCA)	\$0.14	Init.Min.
	\$0.07	Add'l min.		\$0.14	Add'l min.
I (Greater than 40 miles beyond Limited LCA)	\$0.09	Init.Min.	H (Greater than 40 miles Inter-Parish)	\$0.14	Init.Min.
	\$0.07	Add'l min.		\$0.14	Add'l min.

Mississippi			N.Carolina		S.Carolina	
Rate Elements	Rates	Per	Rate Elements	Rates	Rate Elements	Rates
Monthly			Monthly		Monthly	
Residence Port	\$3.75		Residence Port	\$2.00	Residence Port	\$4.00
Business Port	\$7.50		Business Port	\$6.00	Business Port	\$10.50
PBX Trunk Port	\$7.50		PBX Trunk Port	\$8.00	PBX Trunk Port	\$10.50
Rotary Service	\$3.75		Rotary Service	\$1.50	Rotary Service	\$3.00
Usage - Mile Bands			Usage - (STS)		Usage - (STS)	
A (0 miles)	\$0.02	Init.min.	- Init.min.	\$0.05	- Basic Svc.Area	\$0.02
	\$0.01	Add'l min.	- Add'l min.	\$0.02	- Expanded Svc.Area	\$0.12
B (1-10 miles)	\$0.04	Init.min.				
C (11-16 miles, existing LCA described in A3.6 greater than 16 miles, and calls to county seat greater than 16 miles)	\$0.02	Add'l min.				
	\$0.06	Init.min.				
D (17-30 miles)	\$0.04	Add'l min.				
	\$0.09	Init.min.				
E (31-55 miles Biloxi LATA)	\$0.07	Add'l min.				
	\$0.09	Init.min.				
F (31-55 miles Jackson LATA)	\$0.07	Add'l min.				
	\$0.12	Init.min.				
G (56-85 miles Biloxi LATA)	\$0.10	Add'l min.				
	\$0.18	Init.min.				
	\$0.14	Add'l min.				

Tennessee		
Rate Elements	Rates	Per
Monthly		
Residence Port	\$4.00	
Business Port	\$10.00	
PBX Trunk Port	\$10.00	
Rotary Service	\$8.50	
Usage - Mile Bands		
A (0-16 miles)	\$0.02	mou
B (17-30 miles)	\$0.05	mou
C >30 miles	\$0.10	mou