

COMMONWEALTH OF KENTUCKY
BEFORE THE PUBLIC SERVICE COMMISSION

RECEIVED

FEB 06 2013

PUBLIC SERVICE
COMMISSION

In the matter of:

THE APPLICATION OF EAST KENTUCKY NETWORK)
LIMITED LIABILITY COMPANY FOR THE ISSUANCE)
OF A CERTIFICATE OF PUBLIC CONVENIENCE AND) CASE No 2012-00452
NECESSITY TO CONSTRUCT A TOWER IN FLOYD)
COUNTY, KENTUCKY).

East Kentucky Network, LLC, d/b/a Appalachian Wireless, was granted authorization to provide cellular service in the KY-9 Cellular Market Area (CMA451) by the Federal Communications Commission (FCC). FCC license is included as Exhibit 1. East Kentucky Network, LLC merger documents were filed with the Commission on February 2, 2001 in Case # 2001-022.

In an effort to improve service in Floyd County, East Kentucky Network, LLC pursuant to KRS 278.020 Subsection 1 and 807 KAR 5:001 Section 9 is seeking the Commission's approval to construct a 300 foot self-supporting tower on a tract of land located off of C Nelson Drive, David, Floyd County, Kentucky (37°36'30.4"N 82°52'03.4"W). A map and detailed directions to the site can be found in Exhibit 8.

Exhibit 2 is a list of all Property owners or residents according to the property valuation administrator's record who reside or own property within 500 feet of the proposed tower in accordance with the Public Valuation Administrator. No other properties are contiguous with East Kentucky Network's property.

Pursuant to 807 KAR 5:063 Section 1 (1)(L) and Section 1(1)(n)(1) all affected property owners according to the property valuation administrator's record who reside or own property within 500 feet of the proposed Tower were notified by certified mail return receipt requested of East Kentucky Network, LLC's proposed construction and informed of their right to intervene.

They were given the docket number under which this application is filed. Enclosed in Exhibit 2 is a copy of that notification.

Floyd County has no formal local planning unit. In absence of this unit the Floyd County Judge Executive's office was notified by certified mail, return receipt requested of East Kentucky Network Limited Liability Company's proposal and informed of their right to intervene. They were given the docket number under which this application is filed. Enclosed in Exhibit 3 is a copy of that notification.

Notice of the location of the proposed construction was published in the Floyd County Times' January 25th & 30th and February 1st & 6th editions. Enclosed is a copy of that notice in Exhibit 3. The Floyd County Times is the newspaper with the largest circulation in Floyd County.

A geologist was employed to determine soil and rock types and to ascertain the distance to solid bedrock. The geotechnical report is enclosed as Exhibit 4.

A copy of the tower design information is enclosed as Exhibit 5. The proposed tower has been designed by engineers at Allstate Tower and will be constructed under their supervision. Their qualifications are evidenced in Exhibit 5 by the seal and signature of the registered professional engineer responsible for this project.

The tower will be erected by S & S Tower Services of St. Albans, West Virginia. S & S Tower Services has vast experience in the erection of communications towers.

FAA and Kentucky Airport Zoning Commission applications are included as Exhibit 6.

No Federal Communications Commission approval is required prior to construction of this facility. Once service is established from this tower we must immediately notify the Federal Communications Commission of its operation. Prior approval is needed only if the proposed facility increases the size of the cellular geographic service area. This cell site will not expand the cellular geographic service area.

East Kentucky Network, LLC will finance the subject Construction with earned surplus in its General Fund.

Estimated Cost of Construction	\$ 350,000.00
Annual Operation Expense of Tower	\$ 12,500.00

Two notice signs meeting the requirements prescribed by 807 KAR 5:063, Section 1(2), measuring at least two (2) feet in height and four (4) feet in width and containing all required language in letters of required height, have been posted, one at a visible location on the proposed site and one on the nearest public road. The two signs were posted on January 25, 2013 and will remain posted for at least two weeks after filing of this application as specified.

Enclosed in Exhibit 9 is a copy of East Kentucky Network LLC's lease to the site and a lot description of the property.

The proposed construction site is on a very rugged mountaintop some feet from the nearest structure. Prior to construction the site was wooded.

Due to the steep hillside surrounding the proposed site, the property in close proximity is unsuitable for any type of development. East Kentucky Network LLC's operation will not affect the use of nearby land nor its value. No more suitable site exists in the area. A copy of the search area map is enclosed in Exhibit 8. No other tower capable of supporting East Kentucky Network LLC's load exists in the general area; therefore, there is no opportunity for co-location of our facilities with anyone else.

Enclosed, and filed as Exhibit 10 is a survey of the proposed tower site signed by a Kentucky registered professional engineer.

Exhibit 12 contains a vertical sketch of the tower supplied by Coleman Engineering.

WHEREFORE, Applicant respectfully requests that the PSC accept the foregoing Application for filing, and having met the requirements of KRS [278.020(1), 278.650, and 278.665] and all applicable rules and regulations of the PSC, grant a Certificate of Public Convenience and Necessity to construct and operate the proposed tower.

The foregoing document was prepared by Lynn Haney, Compliance Coordinator for East Kentucky Network, LLC d/b/a Appalachian Wireless. All related questions or correspondence concerning this filing should be mailed to East Kentucky Network, LLC d/b/a/ Appalachian Wireless, 101 Technology Trail, Ivel, KY 41642.

SUBMITTED BY: Lynn Haney DATE: 2/1/13
Lynn Haney, Compliance Coordinator

APPROVED BY: Gerald F. Robinette DATE: 2-1-13
Gerald Robinette, General Manager

CONTACT INFORMATION:

Gerald Robinette, General Manager
Phone: (606) 477-2355, Ext. 110
Email: grobinette110@ekn.com

Lynn Haney, Compliance Coordinator
Phone: (606) 477-2355, Ext. 1007
Email: lhaney@ekn.com

Mailing Address:

East Kentucky Network, LLC
d/b/a Appalachian Wireless
101 Technology Trail
Ivel, KY 41642

1	FCC License
2	Copies of Cell Site Notices to Land Owners
3	Notification of County Judge Executive and Newspaper Advertisement
4	Universal Soil Bearing Analysis
5	Tower Design
6	FAA & Kentucky Airport Zoning Commission Applications
7	Audited Financial Statements
8	Driving Directions from County Court House and Map to Suitable Scale
9	Lease Agreement for Proposed Site with Deed Description
10	Survey of Site Signed/Sealed by Professional Engineer Registered in State of Kentucky
11	Site Survey Map with Property Owners Identified in Accordance with PVA of County
12	Vertical Profile Sketch of Proposed Tower

ULS License

Cellular License - KNKN880 - East Kentucky Network, LLC d/b/a Appalachian Wireless

Call Sign	KNKN880	Radio Service	CL - Cellular
Status	Active	Auth Type	Regular

Market

Market	CMA451 - Kentucky 9 - Elliott	Channel Block	B
Submarket	0	Phase	2

Dates

Grant	08/30/2011	Expiration	10/01/2021
Effective	08/30/2011	Cancellation	

Five Year Buildout Date

10/23/1996

Control Points

1 U.S. 23, HAROLD, KY

Licensee

FRN	0001786607	Type	Limited Liability Company
-----	------------	------	---------------------------

Licensee

East Kentucky Network, LLC d/b/a Appalachian Wireless	P:(606)477-2355
101 Technology Trail	F:(606)874-7551
Ivel, KY 41642	
ATTN Gerald Robinette, Manager	

Contact

Lukas, Nace, Gutierrez & Sachs, LLP	P:(703)584-8665
Pamela L Gist Esq	F:(703)584-8695
8300 Greensboro Drive	E:pgist@fcclaw.com
McLean, VA 22102	

Ownership and Qualifications

Radio Service	Mobile
Type	
Regulatory Status	Common Carrier Interconnected Yes

Alien Ownership

The Applicant answered "No" to each of the Alien Ownership questions.

Basic Qualifications

The Applicant answered "No" to each of the Basic Qualification questions.

Demographics

Race

Ethnicity

Gender

EXHIBIT II: LIST OF PROPERTY OWNERS:

Statement Pursuant to Section 1 (1) (I) 807 KAR 5:063

Section 1 (1)(I) 1. The following is a list of every property owner who according to property valuation administrator's records, owns property within 500 feet of the proposed tower and each have been: notified by certified mail, return receipt requested, of the proposed construction,

Section 1 (1)(I) 2. Every person listed below who, according to the property valuation administrator's records, owns property within 500 feet of the proposed tower has been: Given the Commission docket number under which the application will be processed: and

Section 1 (1)(I) 3. Every person listed below who, according to property valuation administrator's records, owns property within 500 feet of the proposed tower has been: Informed of his right to request intervention.

LIST OF PROPERTY OWNERS

Charles & Ruth Ann Nelson
76 C Nelson Drive
David, KY 41616

Big Branch Holding Company, LLC
P.O. Box 700
Prestonsburg, KY 41653

EAST KENTUCKY NETWORK
101 TECHNOLOGY TRAIL
IVEL, KY 41642
PHONE: (606) 874-7550
FAX: (606) 874-7551
EMAIL: INFO@EKN.COM
WEBSITE: WWW.EKN.COM

EAST KENTUCKY
NETWORK



VIA: U.S. CERTIFIED MAIL

February 1, 2013

Charles & Ruth Ann Nelson
76 C Nelson Drive
David, KY 41616

RE: Public Notice-Public Service Commission of Kentucky (Case No. 2012-00452)

East Kentucky Network, LLC d/b/a Appalachian Wireless is applying to the Public Service Commission of Kentucky for a Certificate of Public Convenience and Necessity to construct and operate a new facility to provide cellular telecommunications service in Floyd County. The facility will include a 300 foot self supporting tower with attached antennas extending upwards, and an equipment shelter on a tract of land located off of C Nelson Drive, David, Floyd County, Kentucky. A map showing the location of the proposed new facility is enclosed. This notice is being sent to you because you may own property or reside within a 500' radius of the proposed tower.

The Commission invites your comments regarding the proposed construction. You also have the right to intervene in this matter. The Commission must receive your initial communication within 20 days of the date of this letter as shown above.

Your comments and request for intervention should be addressed to: Executive Director's Office, Public Service Commission of Kentucky, P.O. Box 615, Frankfort, KY 40602. Please refer to Case No. 2012-00452 in your correspondence.

If you have any questions for East Kentucky Network, LLC, please direct them to my attention at the following address: East Kentucky Network, LLC, 101 Technology Trail, Ivel, KY 41642 or call me at 606-477-2355, Ext. 1007.

Sincerely,

Lynn Haney
Compliance Coordinator

Enclosure 1

EAST KENTUCKY NETWORK
101 TECHNOLOGY TRAIL
IVEL, KY 41642
PHONE: (606) 874-7550
FAX: (606) 874-7551
EMAIL: INFO@EKN.COM
WEBSITE: WWW.EKN.COM

EAST KENTUCKY
NETWORK



VIA: U.S. CERTIFIED MAIL

February 1, 2013

Big Branch Holding Company, LLC
P.O. Box 700
Prestonsburg, KY 41653

RE: Public Notice-Public Service Commission of Kentucky (Case No. 2012-00452)

East Kentucky Network, LLC d/b/a Appalachian Wireless is applying to the Public Service Commission of Kentucky for a Certificate of Public Convenience and Necessity to construct and operate a new facility to provide cellular telecommunications service in Floyd County. The facility will include a 300 foot self supporting tower with attached antennas extending upwards, and an equipment shelter on a tract of land located off of C Nelson Drive, David, Floyd County, Kentucky. A map showing the location of the proposed new facility is enclosed. This notice is being sent to you because you may own property or reside within a 500' radius of the proposed tower.

The Commission invites your comments regarding the proposed construction. You also have the right to intervene in this matter. The Commission must receive your initial communication within 20 days of the date of this letter as shown above.

Your comments and request for intervention should be addressed to: Executive Director's Office, Public Service Commission of Kentucky, P.O. Box 615, Frankfort, KY 40602. Please refer to Case No. 2012-00452 in your correspondence.

If you have any questions for East Kentucky Network, LLC, please direct them to my attention at the following address: East Kentucky Network, LLC, 101 Technology Trail, Ivel, KY 41642 or call me at 606-477-2355, Ext. 1007.

Sincerely,

Lynn Haney
Compliance Coordinator

Enclosure 1

Location Map

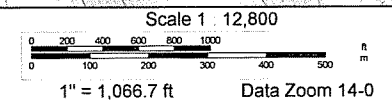
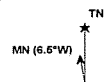
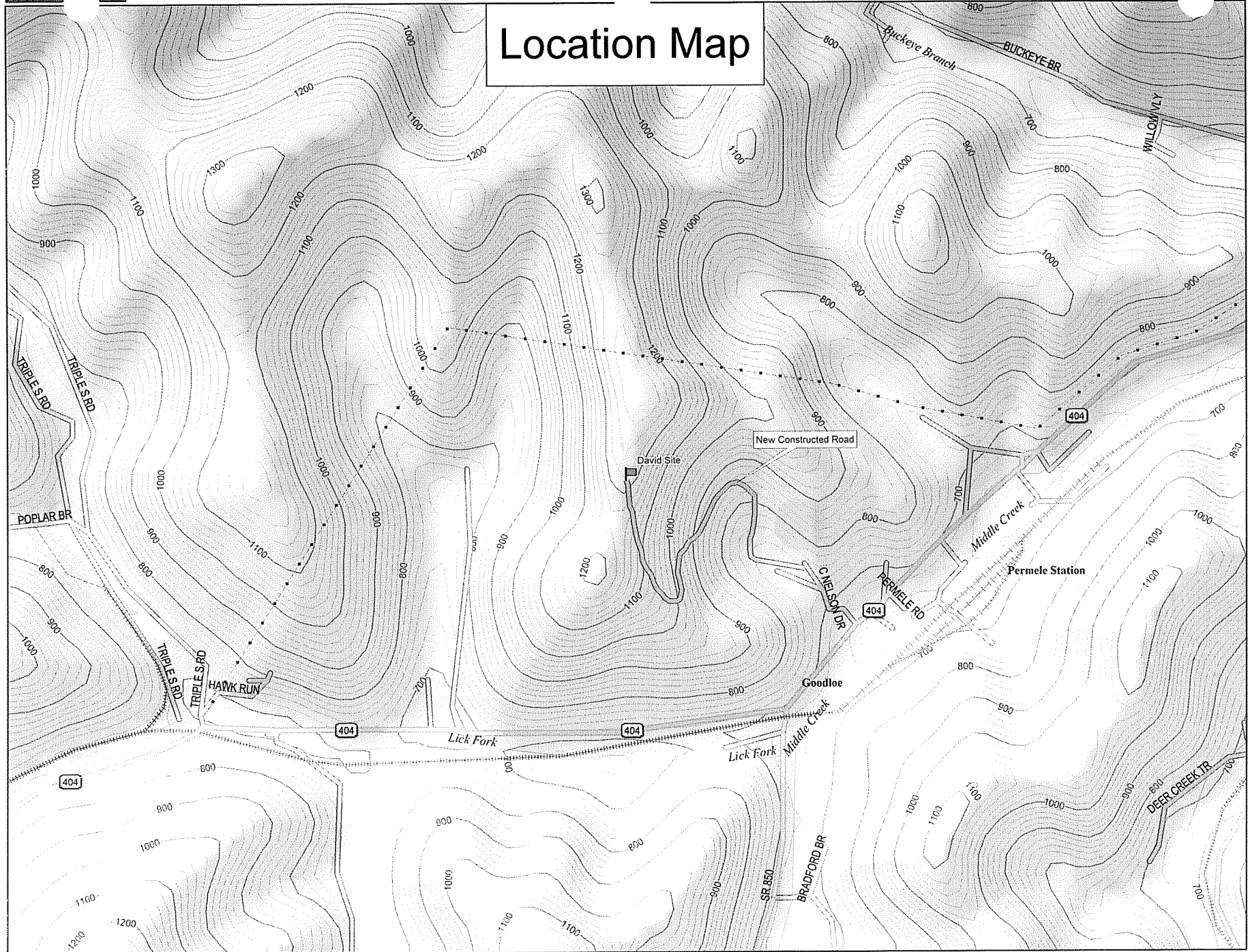

EAST KENTUCKY NETWORK
101 TECHNOLOGY TRAIL
IVEL, KY 41642
PHONE: (606) 874-7550
FAX: (606) 874-7551
EMAIL: INFO@EKN.COM
WEBSITE: WWW.EKN.COM



VIA: U.S. CERTIFIED MAIL

February 1, 2013

Robert D. Marshall, Judge Executive
149 S Central Ave
Prestonsburg, KY 41653

RE: Public Notice-Public Service Commission of Kentucky (Case No. 2012-00452)

East Kentucky Network, LLC d/b/a Appalachian Wireless has applied to the Public Service Commission of Kentucky for a Certificate of Public Convenience and Necessity to construct and operate a new facility to provide cellular telecommunications service in Floyd County. The facility will include a 300 foot self-supporting tower with attached antennas extending upwards, and an equipment shelter on a tract of land located off of C Nelson Drive, David, Floyd County, Kentucky. A map showing the location of the proposed new facility is enclosed. This notice is being sent to you because you are the County Judge Executive of Floyd County.

The Commission invites your comments regarding the proposed construction. You also have the right to intervene in this matter. The Commission must receive your *initial* communication within 20 days of the date of this letter as shown above.

Your comments and request for intervention should be addressed to: Executive Director's Office, Public Service Commission of Kentucky, P.O. Box 615, Frankfort, KY 40602. Please refer to Case No. 2012-00452 in your correspondence.

If you have any questions for East Kentucky Network, LLC, please direct them to my attention at the following address: East Kentucky Network, LLC, 101 Technology Trail, Ivel, KY 41642 or call me at 606-477-2355, Ext. 1007.

Sincerely,

A handwritten signature in cursive script that reads "Lynn Haney".

Lynn Haney
Compliance Coordinator

Enclosure 1

Location Map

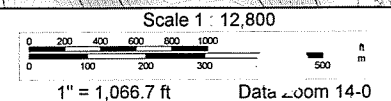
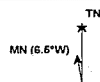
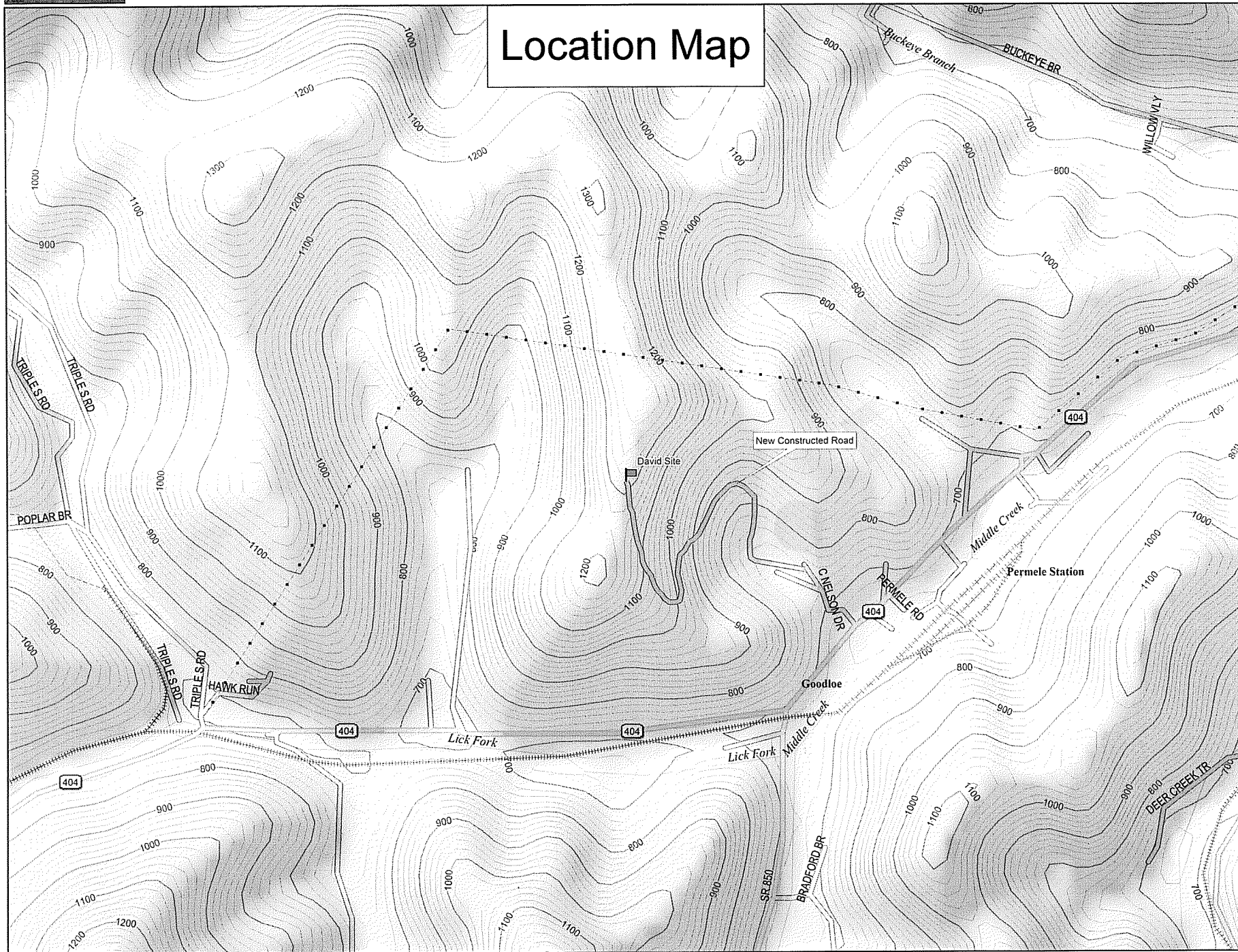

dba Appalachian Wireless
101 Technology Trail
Ivel, KY 41642
Phone: 606-477-2355
Fax: 606-791-2225

EAST KENTUCKY
NETWORK

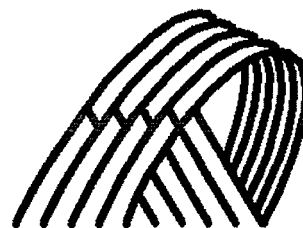

To:	Floyd County Times Attn: Classifieds	From:	Lynn Haney Compliance Coordinator
Email:	fctclassifieds@floydcountytimes.com	Date:	January 22, 2013
Re:	PUBLIC NOTICE ADVERTISEMENT	Pages:	1

Please place the following Public Notice Advertisement in the Floyd County Times to be ran for 2 weeks.

PUBLIC NOTICE:

RE: Public Service Commission of Kentucky (CASE NO. 2012-00452)

Public Notice is hereby given that East Kentucky Network, LLC, dba Appalachian Wireless has applied to the Kentucky Public Service Commission to construct a cellular telecommunications tower on a tract of land located off of C Nelson Drive, David, Floyd County, Kentucky. The proposed tower will be a 300 foot self-supporting tower with attached antennas. If you would like to respond to this notice, please contact the Executive Director, Public Service Commission, 211 Sower Boulevard, PO Box 615, Frankfort, Kentucky 40602. Please refer to Case No. 2012-00452.

If you have any questions about the placement of the above mentioned notice, please call me at 606-477-2375, ext. 1007.

Thank you,

Lynn Haney
Compliance Coordinator

The message above and the information contained in the documents transmitted are confidential and intended only for the person(s) named above. Dissemination, distribution or copying of this communication by anyone other than the person(s) named above is prohibited. If you have received this communication in error, please notify us immediately by telephone and return the original message to us at the address listed above via regular mail. Thank you.

WENDELL R. HOLMES, P.G.

424 Pear Street
Hazard, KY 41701
July 17, 2012

David Tower Site

Purpose:

A site assessment was conducted for Appalachian Wireless on a tract of land located in Floyd County near David, Kentucky. The site of the proposed tower is now forestland. The purpose of this investigation was to determine the depth to bedrock and of what type of rock the bedrock consists.

Site Investigation:

The trenching method was used to determine the type of bedrock material at the proposed tower site. A Caterpillar excavator was used to expose the bedrock material. It is approximately 4.0 feet to the sandstone with shale bedrock. (See attached page for descriptions of materials encountered.) The terrain in Floyd County is moderately to very steep. The tower site is located on top of a ridge 0.6 miles northwest of the confluence of Lick Fork and Left Fork of Middle Creek of the Levisa Fork of the Big Sandy River near the community of Goodloe in Floyd County. The sandstone with shale formation below the tower site is approximately 10.00 feet thick based on the information obtained from the site investigation and geological maps of the area.

Conclusions:

The proposed tower site is located on a ridge in the area. The sandstone with shale bedrock on the proposed tower site is part of the Breathitt Formation, and is middle to lower Pennsylvanian in age. Tests were not conducted to determine the load-bearing strength of the bedrock. However, it is apparent that the tower will be constructed on the shale bedrock formation.

The field work for this site was performed by Wendell R. Holmes, using generally accepted methods in the practice of geological science.

Wendell R. Holmes, P.G.



WENDELL R. HOLMES, P.G.

**424 Pear Street
Hazard, Ky. 41701
(606)438-7250**

Geologist Log

Location: David Tower Site

Unit Thickness	Total depth	Strata	Description
4.00'	4.00'	Soil	Gray, Brown with Shale & Sandstone Fragments
10.00'	14.00'	Sandstone w/ Shale	Weathered, Hard, Brown and Gray

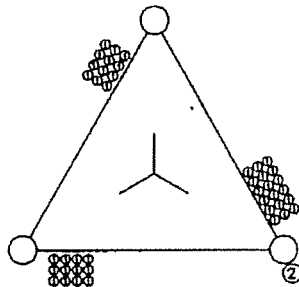
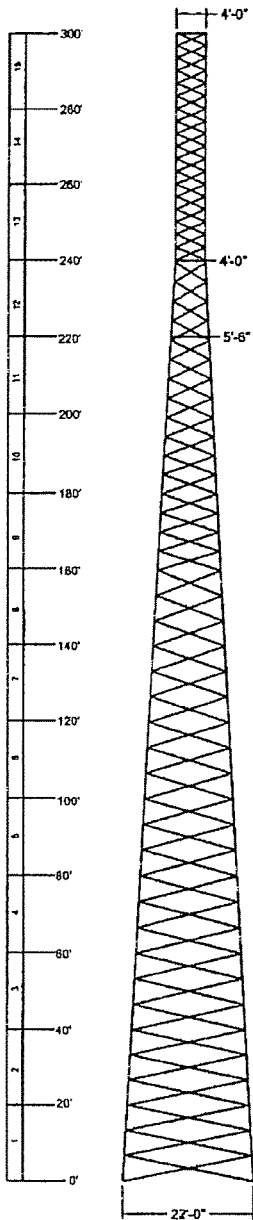

PLAN VIEW

PLAN VIEW REF:
 1) 1-5/8" FEED LINES
 2) STEP BOLTS

BASE REACTIONS:(FACTORED)
 TOTAL SHEAR = 41 KIPS
 AXIAL LOAD = 76 KIPS
 UPLIFT / LEG = 332 KIPS
 COMP. / LEG = 398 KIPS
 O.T. MOMENT = 7105 FT-K

MEMBER INFORMATION

SECTION	ELEVATION	FACE SIZE	LEG DIA.	DIAGONALS	GIRTS	# OF BAYS
1	0' - 20'	22'-0"	Ø4 1/2"	L 3 1/2" x 1/4"	N/A	3 - X
2	20' - 40'	20'-6"	Ø4 1/4"	L 3 1/2" x 1/4"	N/A	3 - X
3	40' - 60'	19'-0"	Ø4 1/4"	L 3" x 1/4"	N/A	3 - X
4	60' - 80'	17'-6"	Ø4 1/4"	L 3" x 1/4"	N/A	3 - X
5	80' - 100'	16'-0"	Ø4"	L 3" x 3/16"	N/A	3 - X
6	100' - 120'	14'-6"	Ø4"	L 2 1/2" x 3/16"	N/A	3 - X
7	120' - 140'	13'-0"	Ø4"	L 2 1/2" x 3/16"	N/A	3 - X
8	140' - 160'	11'-6"	Ø3 3/4"	L 2 1/2" x 3/16"	N/A	3 - X
9	160' - 180'	10'-0"	Ø3 1/2"	L 2" x 3/16"	N/A	4 - X
10	180' - 200'	8'-6"	Ø3 1/4"	L 1 3/4" x 3/16"	N/A	4 - X
11	200' - 220'	7'-0"	Ø3 1/4"	L 1 3/4" x 3/16"	N/A	4 - X
12	220' - 240'	5'-6"	Ø3"	L 1 3/4" x 3/16"	N/A	4 - X
13	240' - 260'	4'-0"	Ø3"	L 1 3/4" x 3/16"	N/A	4 - X
14	260' - 280'	4'-0"	Ø2 1/2"	L 1 1/2" x 3/16"	N/A	4 - X
15	280' - 300'	4'-0"	Ø1 3/4"	L 1 1/2" x 3/16"	L 1 1/2" x 3/16"	4 - X

ANTENNA INFORMATION

ELEVATION	ANTENNA	LINE
300'		(8) 1 5/8"
292'	(12) KATHREIN SCALA	(12) 1 5/8"
280'	(12) KATHREIN SCALA	(12) 1 5/8"
260'	(6) WPA	(6) 1 5/8"
220'	(1) 8' DISH W/ RADOME	(1) 1 5/8"
200'	(1) 8' DISH W/ RADOME	(1) 1 5/8"
180'	(1) 6' DISH W/ RADOME	(1) 1 5/8"
120'	(1) 4' DISH W/ RADOME	(1) 1 5/8"
100'	(1) 6' DISH W/ RADOME	(1) 1 5/8"
80'	(1) 6' DISH W/ RADOME	(1) 1 5/8"

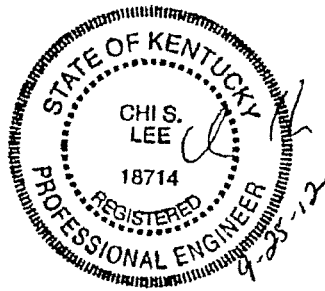

DESIGN NOTES:

- TOWER LEGS ARE CONSTRUCTED OF SOLID ROUND BAR MATERIAL.
- SOLID ROUND 0.75" AND LARGER ASTM A-672 GRADE : 50 KSI MIN.
- SOLID ROUND 0.625" AND SMALLER IS ASTM A-36 GRADE : 36 KSI MIN.
- ALL ANGLE MATERIAL IS ASTM A-529 : 50 KSI MIN.
- ALL BRACE AND FLANGE BOLTS ARE A325-X
- THIS TOWER IS DESIGNED FOR STEP BOLTS UP ONE LEG FOR CLIMBING WITH SAFETY CLIMB DEVICE.
- (8) Ø1 1/2" x 7'-0" LONG (F1554-GR.105) ANCHOR BOLTS PER LEG.
- THIS TOWER IS DESIGNED FOR A 70 M.P.H. WIND SPEED WITH NO ICE AND FOR A 60 M.P.H. WIND SPEED WITH .5' IN ICE. IN ACCORDANCE WITH THE TIA/EIA-222-F STANDARD.
- TOWER HEIGHT A.G.L. INCLUDING LIGHTNING ROD = 304'

APPROX. WEIGHT
 55.3 KIPS

PROPRIETARY STATEMENT: THIS DRAWING IS THE PROPERTY OF ALLSTATE TOWER INC. IT IS NOT TO BE REPRODUCED OR COPIED IN ANYWAY WITHOUT PRIOR WRITTEN CONSENT OF ALLSTATE TOWER INC.



REV #	DESCRIPTION	DATE	BY	UNLESS OTHERWISE NOTED DIMENSIONS ARE IN INCHES	DESCRIPTION
				TOLERANCE BANDS: X ±.0125/0 ANGLES ±.2° XX ±.0125/0 XXX ±.0125/0 HOLES ±.0125/0	TOWER OVERVIEW APPALACHIAN WIRELESS 300' SELF SUPPORT DAVID, HAZARD, KY.
SCALE: NTS				DRAWN BY: J. THOMPSON	FILE NAME: 38732F-SD
				DATE: 9/24/2012	SHEET: A

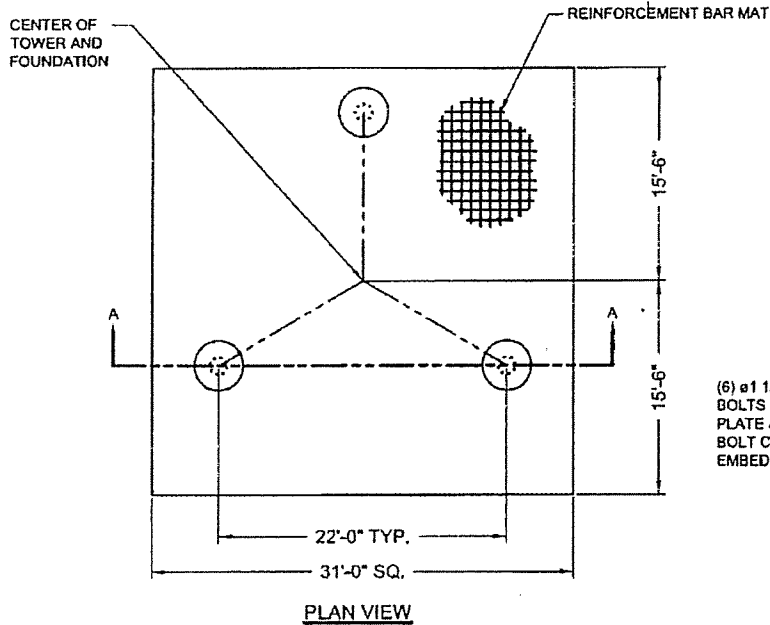

TOTAL VOLUME OF CONCRETE = 84.0 YD³

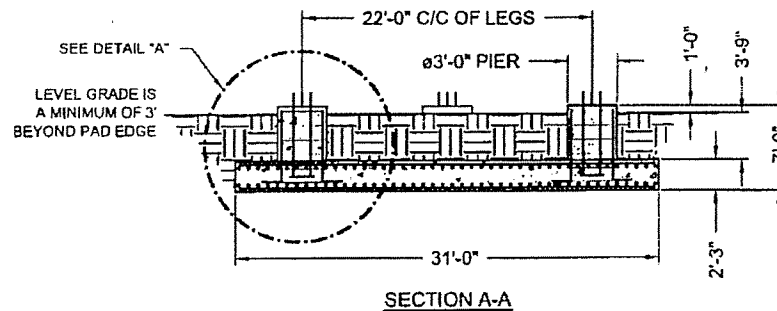

(6) ø 1 1/2" X 7'-0" OVERALL LENGTH ANCHOR BOLTS (F1554-GR105) W/ 3/4" THK BEARING PLATE AT THE BOTTOM OF THE ANCHOR BOLT CLUSTER (8'-0" MIN. ANCHOR BOLT EMBEDMENT).

USE EPOXY BONDING AGENT WHEN POURED SEPARATELY

(12) #9 VERTICAL BARS w/ #5 TIES AT 16" ON CENTER

(36) #9 HORIZONTAL BARS X 30'-6" LONG EQUALLY SPACED EACH WAY AT TOP AND BOTTOM OF MAT. (TOTAL=144)

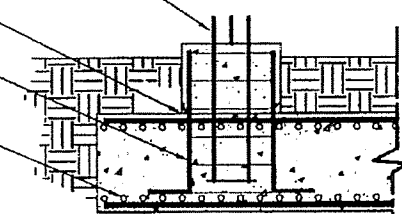

DETAIL "A"

REINFORCEMENT BAR SPlicing:

1. ALL LAP SPLICES SHALL CONFORM TO ACI 318 REQUIREMENTS.
2. REFER TO CHART BELOW WHEN REINFORCEMENT BAR SPlicing IS NECESSARY.

REINFORCING BAR SIZE	LAP SPLICE LENGTH
3	15"
4	17"
5	21"
6	28"
7	30"
8	36"
9	45"
10	58"
11	71"

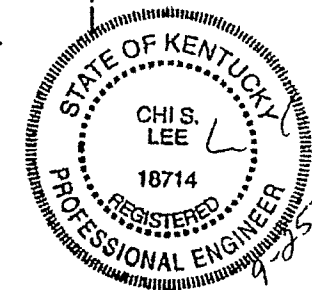

FOUNDATION INSTALLATION/DESIGN NOTES:

1. THIS FOUNDATION IS DESIGNED TO MEET ALL STANDARDS SET FORTH BY ACI 318; AMERICAN CONCRETE INSTITUTE, BUILDING CODE REQUIREMENTS FOR STRUCTURAL CONCRETE, ANSI/AIAA 222-F; STRUCTURAL STANDARDS FOR STEEL ANTENNA TOWERS AND ANTENNA SUPPORTING STRUCTURES.
2. THIS FOUNDATION IS DESIGNED UTILIZING THE GEOTECHNICAL REPORT PERFORMED BY WENDELL HOLMES, P.G.; DATED 7-11-2012. THE FOUNDATION CONTRACTOR SHALL INSTALL THE FOUNDATIONS IN ACCORDANCE WITH THE RECOMMENDATIONS OF THE GEOTECHNICAL REPORT.
3. ALL WORK PERFORMED FROM THESE DRAWINGS SHOULD BE BY QUALIFIED CONTRACTORS EXPERIENCED IN TOWER FOUNDATION CONSTRUCTION.
4. ALL FOOTING EXCAVATIONS SHALL BE MANUALLY CLEANED PRIOR TO PLACING CONCRETE. COMPACT THE EXPOSED SOIL SURFACE AND ANY GRANULAR FILL UNDER THE FOUNDATION TO 95% OF THE MODIFIED PROCTOR DENSITY.
5. ALL CONCRETE SHALL HAVE A MINIMUM COMPRESSIVE STRENGTH OF 4000 PSI AFTER 28 DAYS. COPIES OF THE CONCRETE CYLINDER TEST REPORTS SHALL BE SENT TO THE RESIDENT ENGINEER / INSPECTOR.
6. MINIMUM CONCRETE COVER FOR REINFORCING BARS SHALL BE 3".
7. FIELD BENDING OR WELDING OF REINFORCING BARS IS NOT PERMITTED.
8. PROVIDE CHAMFERS AT ALL EXPOSED CORNERS OF CONCRETE.
9. BACKFILL NEAR AND AROUND THE FOUNDATIONS SHALL BE A WELL GRADED FILL MATERIAL PLACED IN 8" THICK LAYERS THAT HAS BEEN COMPACTED TO 95% OF THE MODIFIED PROCTOR DENSITY PER ASTM D1557.
10. SOME DETAIL HAS BEEN PURPOSELY OMITTED TO CLARIFY ILLUSTRATION.



ALLSTATE TOWER INC.
P.O. BOX 29
MENDOTA, KY 42419
PHONE: (270) 830-4512
FAX: (270) 830-4473
WWW.ALLSTATETOWER.COM

PROPRIETARY STATEMENT: THIS DRAWING IS THE PROPERTY OF ALLSTATE TOWER INC. IT IS NOT TO BE REPRODUCED OR COPIED IN ANYWAY WITHOUT PRIOR WRITTEN CONSENT OF ALLSTATE TOWER INC.

REV #	DESCRIPTION	DATE	BY	UNLESS OTHERWISE NOTED DIMENSIONS ARE IN:
				INCHES
				TOLERANCE BANDS:
				X ±.02" / 0 ANCHORS ±.2"
				XX ±.03" / 0
				XXX ±.01" / 0 HOLES ±.01" / 4
				DRAWN BY: J. THOMPSON
				DATE: 9/24/2012

DESCRIPTION:	FILE NAME:	SHEET
PAD & PIER FOUNDATION DESIGN APPALACHIAN WIRELESS DAVID, HAZARO, KY.	38732F-B	B



Federal Aviation Administration

<< OE/AAA

Notice of Proposed Construction or Alteration - Off Airport

Project Name: EAST -000225422-12 Sponsor: East Kentucky Network, LLC

Details for Case : David

Show Project Summary

Case Status		Date Accepted: 12/20/2012	
ASN:	2012-ASO-11533-OE	Date Determined:	
Status:	Accepted	Letters:	None
Public Comments:	None	Documents:	12/20/2012 David_1A Survey.pdf
		Project Documents:	None
Construction / Alteration Information		Structure Summary	
Notice Of:	Construction	Structure Type:	Tower
Duration:	Permanent	Structure Name:	David
if Temporary :	Months: Days:	NOTAM Number:	
Work Schedule - Start:	01/15/2013	FCC Number:	
Work Schedule - End:	01/20/2013	Prior ASN:	
<i>*For temporary cranes-Does the permanent structure require separate notice to the FAA? To find out, use the Notice Criteria Tool. If separate notice is required, please ensure it is filed. If it is not filed, please state the reason in the Description of Proposal.</i>			
State Filing:	Filed with State		
Structure Details		Common Frequency Bands	
Latitude:	37° 36' 30.40" N	Low Freq	High Freq
Longitude:	82° 52' 3.40" W	698	806
Horizontal Datum:	NAD83	806	824
Site Elevation (SE):	1224 (nearest foot)	824	849
Structure Height (AGL):	310 (nearest foot)	851	866
<i>* If the entered AGL is a proposed change to an existing structure's height include the current AGL in the Description of Proposal.</i>		869	894
Requested Marking/Lighting:	Dual-red and medium intensity	896	901
Other :		901	902
Recommended Marking/Lighting:		930	931
Current Marking/Lighting:	N/A New Structure	931	932
Other :	<input type="text"/>	932	932.5
		935	940
Nearest City:	David	940	941
Nearest State:	Kentucky	1850	1910
Description of Location:	Approx. 1.3 miles NE of David (Floyd), KY	1930	1990
Description of Proposal:	A new 300' tower with top-mounted antennas (overall height of 310' AGL).	2305	2310
		2345	2360

Kentucky Transportation Cabinet, Kentucky Airport Zoning Commission, 200 Mero Street, Frankfort, KY 40622

Kentucky Aeronautical Study Number

APPLICATION FOR PERMIT TO CONSTRUCT OR ALTER A STRUCTURE

INSTRUCTIONS INCLUDED

1. APPLICANT -- Name, Address, Telephone, Fax, etc
East Kentucky Network, LLC
c/o Lukas, Nace, Gutierrez & Sachs, Chtd
8300 Greensboro Drive, Suite 1200
McLean, VA 22102
T: 703-584-8667 F: 703-584-8692

9. Latitude: 37 ° 36 ' 30 . 4 "

10. Longitude: 82 ° 52 ' 3 4 "

11. Datum: [X] NAD83 [] NAD27 [] Other

12. Nearest Kentucky City: David County Floyd

2. Representative of Applicant -- Name, Address, Telephone, Fax
Ali Kuzehkanani
Lukas, Nace, Gutierrez & Sachs, Chtd
8300 Greensboro Drive, Suite 1200
McLean, VA 22102
T: 703-584-8667 F: 703-584-8692

13. Nearest Kentucky public use or Military airport:
Big Sandy Regional Airport

14. Distance from #13 to Structure: 16.0 mi

15. Direction from #13 to Structure: SW

16. Site Elevation (AMSL): 1,224.00 Feet

17. Total Structure Height (AGL): 310.00 Feet

18. Overall Height (#16 + #17) (AMSL): 1,534.00 Feet

3. Application for: [X] New Construction [] Alteration [] Existing

4. Duration: [X] Permanent [] Temporary (Months Days)

5. Work Schedule: Start 1/15/2013 End 1/20/2013

19. Previous FAA and/or Kentucky Aeronautical Study Number(s):

6. Type: [X] Antenna Tower [] Crane [] Building [] Power Line
[] Landfill [] Water Tank [] Other

7. Marking/Painting and/or Lighting Preferred:
[] Red Lights and Paint [X] Dual - Red & Medium Intensity White
[] White - Medium Intensity [] Dual - Red & High Intensity White
[] White - High Intensity [] Other

20. Description of Location: (Attach USGS 7.5 minute Quadrangle Map or an Airport layout Drawing with the precise site marked and any certified survey)

Site is located approx. 1.3 miles NE of David (Floyd), KY

8. FAA Aeronautical Study Number:

21. Description of Proposal:

The structure will include a 300' tower with top-mounted antennas (overall height of 310' AGL). The ERP will be 500 watts.

22. Has a "NOTICE OF CONSTRUCTION OR ALTERATION" (FAA Form 7460-1) been filed with the Federal Aviation Administration?

[] No [X] Yes, When December 20, 2012

CERTIFICATION: I hereby certify that all the above statements made by me are true, complete and correct to the best of my knowledge and belief.

Ali Kuzehkanani/ Dir of Engineering
Printed Name and Title

Signature

12/20/2012
Date

PENALTIES: Persons failing to comply with Kentucky Revised Statutes (KRS 183.861 through 183.990) and Kentucky Administrative Regulations (602 KAR 050:Series) are liable for fines and/or imprisonment as set forth in KRS 183.990(3). Non-compliance with Federal Aviation Administration Regulations may result in further penalties.

Commission Action:

[] Chairman, KAZC

[] Administrator, KAZC

[] Approved

[] Disapproved

Date

**EAST KENTUCKY NETWORK, LLC
DBA APPALACHIAN WIRELESS**

FINANCIAL REPORT

December 31, 2011

CONTENTS

	Page
INDEPENDENT AUDITOR'S REPORT ON THE FINANCIAL STATEMENTS	1
FINANCIAL STATEMENTS	
Balance sheets	2
Statements of income	3
Statements of members' equity	4
Statements of cash flows	5
Notes to financial statements	6-15
INDEPENDENT AUDITOR'S REPORT ON THE SUPPLEMENTARY INFORMATION	16
SUPPLEMENTARY INFORMATION	
Statements of income detail	17 and 18



Jones, Nale & Mattingly PLC

INDEPENDENT AUDITOR'S REPORT

To the Members
East Kentucky Network, LLC
dba Appalachian Wireless
Ivel, Kentucky

We have audited the accompanying balance sheets of East Kentucky Network, LLC, dba Appalachian Wireless as of December 31, 2011 and 2010, and the related statements of income, members' equity and cash flows for the years then ended. These financial statements are the responsibility of the Company's management. Our responsibility is to express an opinion on these financial statements based on our audits.

We conducted our audits in accordance with auditing standards generally accepted in the United States of America. Those standards require that we plan and perform the audit to obtain reasonable assurance about whether the financial statements are free of material misstatement. An audit includes examining, on a test basis, evidence supporting the amounts and disclosures in the financial statements. An audit also includes assessing the accounting principles used and significant estimates made by management, as well as evaluating the overall financial statement presentation. We believe that our audits provide a reasonable basis for our opinion.

In our opinion, the financial statements referred to above present fairly, in all material respects, the financial position of East Kentucky Network, LLC, dba Appalachian Wireless as of December 31, 2011 and 2010, and the results of its operations and its cash flows for the years then ended in conformity with accounting principles generally accepted in the United States of America.

Jones, Nale & Mattingly P.C.

Louisville, Kentucky
February 15, 2012

**EAST KENTUCKY NETWORK, LLC
DBA APPALACHIAN WIRELESS**

**BALANCE SHEETS
December 31, 2011 and 2010**

ASSETS	<u>2011</u>	<u>2010</u>
CURRENT ASSETS		
Cash and cash equivalents	\$ 18,579,633	\$ 11,517,807
Short-term investments (Note 9)	100,000	100,000
Accounts receivable, less allowance for doubtful accounts of \$1,767,789 in 2011 and \$1,473,291 in 2010	9,830,698	8,510,532
Accounts receivable, members (Notes 5 and 6)	51,772	120,279
Inventory	4,427,993	5,473,601
Prepaid expenses	729,388	510,762
Total current assets	<u>\$ 33,719,484</u>	<u>\$ 26,232,981</u>
 PROPERTY, PLANT AND EQUIPMENT (Note 3)		
Plant in service:		
General support	\$ 34,918,094	\$ 29,593,635
MTSO equipment	23,759,476	17,622,843
Cell equipment	61,652,026	62,992,099
Paging equipment	1,680,882	2,452,567
Fiber ring	8,143,858	7,802,053
Unfinished plant	3,371,823	5,812,946
	<u>\$133,526,159</u>	<u>\$126,276,143</u>
Less accumulated depreciation	53,684,880	53,217,856
	<u>\$ 79,841,279</u>	<u>\$ 73,058,287</u>
 OTHER ASSETS		
Investment in affiliated company, RTFC	\$ 112,712	\$ 112,712
Intangible assets, net of accumulated amortization of \$5,761,802 in 2011 and \$5,075,704 in 2010 (Note 2)	3,226,715	3,912,813
	<u>\$ 3,339,427</u>	<u>\$ 4,025,525</u>
	<u>\$116,900,190</u>	<u>\$103,316,793</u>

The Notes to Financial Statements are an integral part of these statements.

LIABILITIES AND MEMBERS' EQUITY	<u>2011</u>	<u>2010</u>
CURRENT LIABILITIES		
Current maturities of long-term debt (Notes 3 and 9)	\$ 2,545,238	\$ 2,685,714
Accounts payable	3,440,389	2,339,497
Accounts payable, members (Notes 5 and 6)	33,855	27,707
Accrued expenses	1,909,347	1,970,165
Deferred revenue, advance billings	2,642,605	2,454,257
Customer deposits	539,245	570,375
Total current liabilities	<u>\$ 11,110,679</u>	<u>\$ 10,047,715</u>
LONG-TERM DEBT, less current maturities (Notes 3 and 9)	<u>\$ 8,104,445</u>	<u>\$ 10,873,492</u>
INTEREST RATE SWAPS (Notes 8 and 9)	<u>\$ 931,120</u>	<u>\$ 1,301,598</u>
MEMBERS' EQUITY		
Members' capital accounts	\$ 97,685,066	\$ 82,395,586
Accumulated other comprehensive (loss)	(931,120)	(1,301,598)
	<u>\$ 96,753,946</u>	<u>\$ 81,093,988</u>
	<u><u>\$116,900,190</u></u>	<u><u>\$103,316,793</u></u>

**EAST KENTUCKY NETWORK, LLC
DBA APPALACHIAN WIRELESS**

**STATEMENTS OF INCOME
Years Ended December 31, 2011 and 2010**

	<u>2011</u>	<u>2010</u>
REVENUE		
Retail	\$ 54,274,185	\$ 49,761,597
Roamer	23,098,144	19,899,728
Long distance	127,117	150,913
Paging	325,062	402,317
Equipment sales, cellular	2,656,667	3,194,207
Equipment sales, paging	34,248	63,355
Other	<u>3,474,978</u>	<u>2,975,390</u>
Total revenue	<u>\$ 83,990,401</u>	<u>\$ 76,447,507</u>
EXPENSES		
Cost of cellular service	\$ 17,261,240	\$ 14,859,401
Cost of paging service	291,614	361,793
Cost of equipment sales, cellular	14,694,220	14,723,995
Cost of equipment sales, paging	23,597	35,112
Customer service	1,624,578	1,482,312
Billing	1,861,761	1,730,631
Selling	5,814,292	4,994,147
Maintenance	3,065,832	2,888,565
Utilities	1,117,555	976,530
Bad debts	1,083,570	732,290
Cell site rental	372,666	294,170
Taxes and licenses	864,670	2,026,428
Advertising	4,322,032	3,900,531
General and administrative	4,357,440	4,220,443
Occupancy	527,989	574,325
Depreciation	9,851,168	9,808,536
Amortization	<u>879,497</u>	<u>852,538</u>
Total expenses	<u>\$ 68,013,721</u>	<u>\$ 64,461,747</u>
Income from operations	<u>\$ 15,976,680</u>	<u>\$ 11,985,760</u>
OTHER INCOME (EXPENSE)		
Interest income	\$ 29,774	\$ 25,278
Interest expense	(928,325)	(1,028,373)
Universal Service Fund income (Note 7)	<u>7,919,934</u>	<u>7,371,103</u>
	<u>\$ 7,021,383</u>	<u>\$ 6,368,008</u>
Net income	<u>\$ 22,998,063</u>	<u>\$ 18,353,768</u>

The Note to Financial Statements are an integral part of these statements.

**EAST KENTUCKY NETWORK, LLC
DBA APPALACHIAN WIRELESS**

**STATEMENTS OF MEMBERS' EQUITY
Years Ended December 31, 2011 and 2010**

	Cellular Services, LLC	Gearhart Communi- cations Company, Inc.	Mountain Tele- communi- cations, Inc.	Thacker- Grigsby Telephone Co., Inc.	Peoples Rural Telephone Coop- erative Corp- oration, Inc.	Total
Balance, January 1, 2010	\$13,885,889	\$13,885,889	\$13,885,889	\$13,885,888	\$13,885,889	\$69,429,444
Comprehensive income:						
Net income	3,670,754	3,670,753	3,670,753	3,670,754	3,670,754	18,353,768
Change in fair value of interest rate swaps	16,532	16,532	16,533	16,533	16,533	82,663
Total comprehensive income	\$ 3,687,286	\$ 3,687,285	\$ 3,687,286	\$ 3,687,287	\$ 3,687,287	\$18,436,431
Capital distributions	<u>(1,354,377)</u>	<u>(1,354,377)</u>	<u>(1,354,378)</u>	<u>(1,354,377)</u>	<u>(1,354,378)</u>	<u>(6,771,887)</u>
Balance, December 31, 2010	\$16,218,798	\$16,218,797	\$16,218,797	\$16,218,798	\$16,218,798	\$81,093,988
Comprehensive income:						
Net income	4,599,613	4,599,613	4,599,613	4,599,612	4,599,612	22,998,063
Change in fair value of interest rate swaps	74,095	74,095	74,096	74,096	74,096	370,478
Total comprehensive income	\$ 4,673,708	\$ 4,673,708	\$ 4,673,709	\$ 4,673,708	\$ 4,673,708	\$23,368,541
Capital distributions	<u>(1,541,716)</u>	<u>(1,541,716)</u>	<u>(1,541,717)</u>	<u>(1,541,717)</u>	<u>(1,541,717)</u>	<u>(7,708,583)</u>
Balance, December 31, 2011	<u>\$19,350,790</u>	<u>\$19,350,789</u>	<u>\$19,350,789</u>	<u>\$19,350,789</u>	<u>\$19,350,789</u>	<u>\$96,753,946</u>

The Notes to Financial Statements are an integral part of these statements.

**EAST KENTUCKY NETWORK, LLC
DBA APPALACHIAN WIRELESS**

**STATEMENTS OF CASH FLOWS
Years Ended December 31, 2011 and 2010**

	2011	2010
CASH FLOWS FROM OPERATING ACTIVITIES		
Net income	\$ 22,998,063	\$ 18,353,768
Adjustments to reconcile net income to net cash provided by operating activities:		
Depreciation	9,851,168	9,808,536
Amortization	879,497	852,538
Loss on disposition of property, plant, and equipment	440,743	593,729
Changes in assets and liabilities, net of the effects of investing and financing activities:		
(Increase) in accounts receivable	(1,320,166)	(703,814)
(Increase) decrease in accounts receivable, members	68,507	(33,087)
Decrease in inventory	1,045,608	225,779
(Increase) decrease in prepaid expenses	(218,626)	26,381
Increase in accounts payable	1,100,892	306,161
Increase (decrease) in accounts payable, members	6,148	(7,499)
Increase (decrease) in accrued expenses	(60,818)	450,303
Increase in deferred revenue, advance billings	188,348	320,514
(Decrease) in customer deposits	(31,130)	(4,621)
Net cash provided by operating activities	\$ 34,948,234	\$ 30,188,688
CASH FLOWS FROM INVESTING ACTIVITIES		
Purchase of property, plant and equipment	\$ (17,313,302)	\$ (12,087,691)
Proceeds from sale of property, plant and equipment	45,000	-
Net cash (used in) investing activities	\$ (17,268,302)	\$ (12,087,691)
CASH FLOWS FROM FINANCING ACTIVITIES		
Capital distributions	\$ (7,708,583)	\$ (6,771,887)
Payments on long-term borrowings	(2,909,523)	(2,685,715)
Net cash (used in) financing activities	\$ (10,618,106)	\$ (9,457,602)
Net increase in cash and cash equivalents	\$ 7,061,826	\$ 8,643,395
Cash and cash equivalents:		
Beginning	11,517,807	2,874,412
Ending	\$ 18,579,633	\$ 11,517,807
SUPPLEMENTAL DISCLOSURE OF CASH FLOW INFORMATION		
Cash payments for interest (net of capitalized interest of zero in 2011 and \$117,887 in 2010)	\$ 979,424	\$ 1,045,454

The Notes to Financial Statements are an integral part of these statements.

**EAST KENTUCKY NETWORK, LLC
DBA APPALACHIAN WIRELESS**

NOTES TO FINANCIAL STATEMENTS

Note 1. Summary of Significant Accounting Policies

Nature of operations

East Kentucky Network, LLC, dba Appalachian Wireless, is a Kentucky limited liability company formed by the merger of Appalachian Cellular, LLC, Mountaineer Cellular, LLC and East Kentucky Network, LLC on January 1, 2000. The Company is engaged in cellular telephone communications and paging services to residential and commercial customers located in eastern Kentucky. The Company's five members consist of Cellular Services, LLC; Gearheart Communications Company, Inc.; Mountain Telecommunications, Inc.; Peoples Rural Telephone Cooperative Corporation, Inc.; and Thacker-Grigsby Telephone Co., Inc.

Use of estimates

Management uses estimates and assumptions in preparing financial statements. Those estimates and assumptions affect the reported amounts of assets and liabilities, the disclosure of contingent assets and liabilities, and the reported revenues and expenses.

Cash and cash equivalents

For purposes of the statement of cash flows, the Company considers temporary investments having original maturities of three months or less to be cash equivalents. The Company maintains its cash balances, which may exceed the federally insured limit, with several financial institutions. Cash balances included in certain non-interest bearing accounts are insured in fully by the FDIC through December 31, 2012. These financial institutions have strong credit ratings and management believes that credit risk related to the accounts is minimal.

Short-term investments

Certificates of deposit having original maturities between three and nine months are classified as short-term investments, are carried at cost, which approximates fair value, and are held to maturity. Fair value is determined by quoted prices for similar certificates of deposit in active markets (Level 2) as defined by the Fair Value Measurements Topic of the FASB Accounting Standards Codification (see Note 9).

Accounts receivable

Accounts receivable are recorded at net realizable value consisting of the carrying amount less an allowance for uncollectible accounts. The Company uses the allowance method to account for uncollectible accounts receivable balances. Management charges off uncollectible receivables to the allowance when it is determined the amounts will not be realized.

NOTES TO FINANCIAL STATEMENTS

Note 1. Summary of Significant Accounting Policies (Continued)

Inventory

Inventory is composed of cellular telephone equipment, paging equipment, and accessories purchased for resale during the ordinary course of business. The inventory is valued at the lower of cost or market, cost being determined by the first-in, first-out (FIFO) method.

Property, plant and equipment

Property, plant and equipment are recorded at cost. Depreciation is provided using the straight-line method over the estimated useful lives of the assets.

Investment

The investment in affiliated company is composed of equity certificates in Rural Telephone Finance Cooperative and is reported at cost.

Intangible assets

The customer lists, non-compete agreements, FCC licenses, bond issuance costs, loan fees and use of name are recorded at cost and are being amortized over the life of the asset by the straight-line method.

Revenue recognition

Revenue consists primarily of charges for access, airtime, roaming, long distance, data and other value-added services provided to the Company's retail customers; charges to other cellular carriers whose customers use the Company's network when roaming; and sales of phones and accessories.

Revenue from cellular service is recognized monthly when earned, phone and accessory sales are recognized at the point of sale, activation fees are recognized when activation of service occurs, and cancellation penalties are recognized at the time of disconnection from service. Deferred revenue consists of monthly access and feature charges billed one month in advance and recognized as revenue the following month.

The Company's sales contracts are considered multiple deliverable arrangements that generally involve delivery and activation of a cellular phone, plus phone service. Each is treated as a separate unit of accounting. Contracts are subject to one to two-year terms and require the customer to pay a cancellation fee if the customer cancels the contract. There is a one-time activation fee and a monthly fee for the ongoing service. All fees are nonrefundable. The Company uses estimated selling price to determine both the selling price of the phone and for the phone service. The phone and activation are delivered first, followed by the phone service (which is provided over the contract period). Delivery and activation of the phone are considered one element because activation is necessary for the functionality of the phone. Revenue from phone service is recognized separately over the life of the service arrangement.

NOTES TO FINANCIAL STATEMENTS

Note 1. Summary of Significant Accounting Policies (Continued)

Advertising

Advertising costs are expensed as incurred. At December 31, 2011 and 2010, these costs were \$4,322,032 and \$3,900,531, respectively.

Income taxes

Under existing provisions of the Internal Revenue Code, the income or loss of a limited liability company is recognized by the members for income tax purposes. Accordingly, no provision for federal income taxes has been provided for in the accompanying financial statements.

The Company's accounting policy provides that a tax expense/benefit from an uncertain tax position may be recognized when it is more likely than not that the position will be sustained upon examination, including resolutions of any related appeals or litigation processes, based on the technical merits. Management believes the Company has no uncertain tax positions resulting in an accrual of tax expense or benefit.

The Company recognizes interest accrued related to unrecognized tax benefits in interest expense and penalties in operating expenses. The Company did not recognize any interest or penalties during the years ended December 31, 2011 and 2010.

The Company's federal and state income tax returns are subject to possible examination by the taxing authorities until the expiration of the related statutes of limitations on those tax returns. In general, the federal income tax returns have a three year statute of limitations, and the state income tax returns have a four year statute of limitations.

Comprehensive income

Comprehensive income consists of net income and other comprehensive income. Other comprehensive income includes the change in fair value of interest rate swaps which is also recognized as a separate component of equity.

Subsequent events

Management has evaluated subsequent events through February 15, 2012, the date the financial statements were available to be issued.

Reclassification

Certain amounts presented in the prior period have been restated to conform with the current year presentation.

NOTES TO FINANCIAL STATEMENTS

Note 2. Intangible Assets

Intangible assets consist of the following at December 31, 2011:

	<u>Gross Amount</u>	<u>Accumulated Amortization</u>	<u>Weighted Average Life (in years)</u>
Customer lists	\$ 5,363,530	\$ (3,940,516)	15
Non-compete agreements	220,348	(195,016)	15
FCC licenses	2,452,368	(1,061,762)	14
Use of name	10,000	(7,668)	15
Other	942,271	(556,840)	7
	<u>\$ 8,988,517</u>	<u>\$ (5,761,802)</u>	

Intangible assets consist of the following at December 31, 2010:

	<u>Gross Amount</u>	<u>Accumulated Amortization</u>	<u>Weighted Average Life (in years)</u>
Customer lists	\$ 5,363,530	\$ (3,583,198)	15
Non-compete agreements	220,348	(180,336)	15
FCC licenses	2,452,368	(889,418)	14
Use of name	10,000	(7,002)	15
Other	942,271	(415,750)	7
	<u>\$ 8,988,517</u>	<u>\$ (5,075,704)</u>	

Aggregate amortization expense related to these intangible assets for the years ended December 31, 2011 and 2010 totaled \$686,098 for both years. The following represents the total estimated amortization of intangible assets for each of the succeeding five years:

Year ending December 31:

2012	\$ 680,000
2013	660,000
2014	620,000
2015	550,000
2016	275,000

NOTES TO FINANCIAL STATEMENTS

Note 3. Long-Term Debt

Long-term debt consists of the following at December 31:

	2011	2010
Note payable, Fifth Third Bank (a)	\$ 6,116,667	\$ 7,633,333
Note payable, Fifth Third Bank (b)	4,533,016	5,925,873
Line of credit, Fifth Third Bank (c)	--	--
	\$ 10,649,683	\$ 13,559,206

(a) On February 28, 2006, the Company issued \$14,200,000 in adjustable rate notes to restructure its debt. The notes were issued pursuant to a trust indenture between the Company and U.S. Bank National Association. Principal and interest on the notes were paid from funds drawn by the Trustee under an irrevocable letter of credit issued by Fifth Third Bank. The Notes were collateralized by the assets of the Company and were scheduled to mature on February 1, 2016. The Notes bear interest at a floating interest rate as determined by U.S. Bank National Association (4.60% at 12/31/08). However, the Company entered into an interest rate swap contract (original notional amount of \$14,200,000) that effectively converted its floating-rate debt into a fixed-rate of 8.02%.

On February 2, 2009, the Company refinanced the remaining \$10,200,000 of the note with a new note payable that matures November 1, 2013 and is collateralized by the assets of the Company. Interest on the note is floating at monthly LIBOR plus 1.75% as determined by Fifth Third Securities, Inc. (2.02% at 12/31/11). The Company also renegotiated the terms of the interest rate swap contract and entered into an interest rate swap contract (original notional amount of \$10,200,000) that effectively converts its floating-rate debt into a fixed rate of 7.46% (see Note 8). The note is payable in monthly installments of \$116,667 plus interest through February 1, 2012 and \$125,000 plus interest thereafter through November 1, 2013 with a balloon payment due at maturity.

(b) On September 1, 2008, the Company borrowed \$9,000,000 to restructure existing debt, purchase new equipment and upgrade existing equipment. The note is collateralized by the assets of the Company. Interest on the note is floating at monthly LIBOR plus 3.00% as determined by Fifth Third Securities, Inc (3.27% at 12/31/11). The Company also entered into an interest rate swap contract (original notional amount of \$9,000,000) that effectively converts its floating-rate debt into a fixed rate of 7.20% (see Note 8). The note is payable in monthly installments of \$107,143 plus interest with a balloon payment due on September 1, 2013.

(c) On September 9, 2011, the Company entered into a line of credit agreement with Fifth Third Bank that provides for borrowings up to \$12,000,000. The agreement carries a variable interest rate at monthly LIBOR plus 2.25% as determined by Fifth Third Securities, Inc (2.52% at 12/31/11), is secured by assets of the Company, and is due on September 1, 2013.

NOTES TO FINANCIAL STATEMENTS

Note 3. Long-Term Debt (Continued)

Total interest cost for the years ended December 31, 2011 and 2010 was approximately \$928,000 and \$1,146,000, respectively, of which approximately \$118,000 was capitalized in 2010 as part of the construction of a new office building that was placed into service in 2011.

Under terms of the Notes, the Company has also agreed, among other things, to limit distributions, to maintain minimum fixed charge coverage ratios, and to maintain minimum debt to earnings ratios.

Approximate maturities or payments required on principal under note payable agreements for each of the succeeding five years are as follows:

Year ending December 31:	
2012	\$ 2,545,238
2013	8,104,445
2014	--
2015	--
2016	--
	<u>\$ 10,649,683</u>

Note 4. Retirement Plans

The Company has a 401(k) plan for qualifying employees who have reached twenty-one years of age. Eligible employees are allowed to invest up to 15% of their compensation and the Company has agreed to match 100% of the first 3% of the employees' contribution and 50% of the employees' contribution between 3% and 5%. The Company contributed \$148,041 and \$139,405 in matching funds for its 401(k) plan during the years ended December 31, 2011 and 2010, respectively.

The Company also offers an employer sponsored retirement savings plan for qualified employees who have reached twenty-one years of age. The Company has agreed to contribute 9% of the eligible employee's compensation, plus an additional 5% of the original contribution.

The Company contributed \$725,318 and \$638,293 to its retirement savings plan during the years ended December 31, 2011 and 2010, respectively.

Note 5. Related Party Transactions

The Company shares personnel with three of its members. The Company paid \$383,149 and \$251,384 for shared personnel during the years ended December 31, 2011 and 2010, respectively. The Company also leased offices and warehouse space from three members. The leases are for an unspecified length of time. The annual lease expense related to these leases was \$20,858 and \$20,483 for the years ended December 31, 2011 and 2010, respectively.

The Company incurred interconnection, telephone, cable and internet access charges from its members aggregating \$1,329,216 and \$1,206,230 for the years ended December 31, 2011 and 2010, respectively.

NOTES TO FINANCIAL STATEMENTS

Note 5. Related Party Transactions (Continued)

The Company leases two cellular tower sites from the officers and majority shareholders of a member. The annual lease expense related to these leases was \$2,400 for both years ended December 31, 2011 and 2010. The leases are for an unspecified length of time. The Company also pays part of an annual lease for sharing a tower with a member for an annual fee of \$450. In addition, the Company leases one other site from a company owned by a member. The annual lease expense related to this lease for the years ended December 31, 2011 and 2010 amounted to \$11,700 and \$13,350, respectively. The Company leases cellular tower sites from the parent company of one of its other members. The annual lease expense related to these leases was \$12,463 for both years ended December 31, 2011 and 2010. The leases are for five years with options to renew.

The Company pays commissions to its members for phone sales to customers. The amount of commissions paid to related parties during the years ended December 31, 2011 and 2010 was \$323 and \$55,035, respectively.

The Company pays fees to companies owned by its members for advertisement in telephone directories, television and on local billboards. The amount of advertising paid to related parties was \$40,120 and \$61,534 for the years ended December 31, 2011 and 2010, respectively.

Note 6. Operating Leases

The Company has entered into operating leases with its members and other customers to provide fiber optic transmission capacity and ancillary services. The terms of these leases are for 15 years. Total rental income earned from these operating lease commitments included in the statements of income was \$1,016,885 and \$1,214,408 for the years ended December 31, 2011 and 2010, respectively. Rental income earned from the Company's members from these leases was \$846,249 and \$1,008,827 for the years ended December 31, 2011 and 2010, respectively.

Investments in operating leases are as follows at December 31:

	2011	2010
Fiber ring	\$ 8,143,858	\$ 7,802,053
Accumulated depreciation	(3,643,160)	(3,120,944)
	\$ 4,500,698	\$ 4,681,109

The future minimum rental payments expected to be received under these lease agreements for each of the succeeding five years are approximately \$730,000 each year.

NOTES TO FINANCIAL STATEMENTS

Note 6. Operating Leases (Continued)

The Company has also entered into lease agreements to obtain fiber optic transmission and digital microwave transmission services; and to rent retail office facilities. The terms of these leases are between 5 and 15 years. Total rental expense incurred from these operating lease commitments included in the statements of income was \$1,195,368 and \$1,062,254 for the years ended December 31, 2011 and 2010, respectively. Rental expense incurred from the Company's members from these leases was \$464,544 and \$411,196 for the years ended December 31, 2011 and 2010, respectively. The future minimum lease payments required under these lease agreements for each of the succeeding five years are approximately \$1,400,000 each year.

Note 7. Eligible Telecommunication Carrier

During 2005, the Company was granted Eligible Telecommunication Carrier (ETC) status by the Kentucky Public Service Commission. As an ETC, the Company receives funding from the federal Universal Service Fund (USF) to support the high cost of providing local telephone service in rural areas. USF payments amounted to \$7,919,934 and \$7,371,103 for the years ended December 31, 2011 and 2010, respectively.

Note 8. Derivative Financial Instruments, Interest Rate Swaps

The Company entered into two interest rate swap contracts with Fifth Third Bank for the purpose of converting floating-rate interest on its long-term debt to fixed rates. The interest rate swap effectively fixed \$10,200,000 at a rate of 7.46% until February 1, 2016 and fixed \$9,000,000 at a rate of 7.20% until September 1, 2013.

Under the swap contracts, the Company pays interest at 5.71% and 4.20% on the notional amounts and receives interest at LIBOR observed monthly (0.27% at December 31, 2011). The interest rate swaps qualify as, and are designated as, cash flow hedges. The swaps are designed to hedge the risk of changes in interest payments on the notes caused by changes in LIBOR. The notional amounts do not represent actual amounts exchanged by the parties, but instead represent the amounts on which the contracts are based.

The swaps were issued at market terms so that they had no fair value or carrying value at their inception. The carrying amount of the swaps has been adjusted to their fair value at the end of the year, which because of changes in forecasted levels of LIBOR, resulted in reporting a liability for the fair value of the future net payments forecasted under the swaps. The swap contracts permit settlement prior to maturity only through termination by the Company. The settlement amounts are determined based on forecasted changes in interest rates required under fixed and variable legs of the swaps. The Company believes the settlement amounts are the best representation of the fair value of the swaps and has adjusted their carrying amounts to the settlement amounts at the end of the year.

NOTES TO FINANCIAL STATEMENTS

Note 8. Derivative Financial Instruments, Interest Rate Swaps (Continued)

The carrying amounts of the swaps are classified as noncurrent since management does not intend to terminate the swaps during 2011 . Since the critical terms of the swaps and the notes are approximately the same, the swaps are assumed to be effective as hedges, and none of the changes in fair values are included in income. Accordingly, all of the adjustment of the swaps' carrying amount is reported as other comprehensive income or loss in the accompanying statements of members' equity. If the swaps are terminated early, the corresponding carrying amount would be reclassified into earnings. The Company does not hold or issue interest rate swaps or other financial instruments for trading purposes.

Note 9. Fair Values of Financial Instruments

The Fair Value Measurements Topic of the FASB Accounting Standards Codification defines fair value, establishes a framework for measuring fair value, and expands disclosures about fair value measurements. The Fair Value Measurements Topic establishes a fair value hierarchy about the assumptions used to measure fair value and clarifies assumptions about risk and the effect of a restriction on the sale of an asset. The Fair Value Measurements Topic defines fair value as the exchange price that would be received for an asset or paid to transfer a liability (an exit price) in the principal or most advantageous market for the asset or liability in an orderly transaction between market participants on the measurement date. In cases where quoted market prices are not available, fair values are based on estimates using present value or other valuation techniques. Those techniques are significantly affected by the assumptions used, including the discount rate and estimates of future cash flows. Accordingly, the fair value estimates may not be realized in an immediate settlement of the instrument. The Fair Value Measurements Topic also establishes a fair value hierarchy which requires an entity to maximize the use of observable inputs and minimize the use of unobservable inputs when measuring fair value.

The Fair Value Measurements Topic describes three levels of inputs that may be used to measure fair value:

- Level 1 - Quoted prices (unadjusted) of identical assets or liabilities in active markets that the entity has the ability to access as of the measurement date.
- Level 2 - Significant other observable inputs other than Level 1 prices, such as quoted prices of similar assets or liabilities, quoted prices in markets that are not active, and other inputs that are observable or can be corroborated by observable market data.
- Level 3 - Significant unobservable inputs that reflect a company's own assumptions about the assumptions that market participants would use in pricing an asset or liability.

Financial instruments of the Company that are subject to fair value measurements are limited to short-term investments, long-term debt and interest rate swaps. Fair values of these financial instruments have been valued using a market approach and are measured using Level 2 inputs.

NOTES TO FINANCIAL STATEMENTS

Note 9. Fair Values of Financial Instruments (Continued)

The fair value of short-term investments approximates its carrying amount due to the short-term nature of these instruments.

The fair value of long-term debt approximates its carrying amount because its variable rate terms are similar to market terms.

The fair value of the interest rate swaps are based on the approximation of market value derived from proprietary models. This fair value takes into consideration the prevailing interest rate environment and the specific terms and conditions of the derivative financial instrument. The fair value was estimated by comparing the Company's fixed swap rates with the current market rates on identical swaps for the remaining terms. The interest due on each remaining payment date is calculated at the existing swap rate and the current market rate. Fair market value is the present value of the difference between those payment streams. The value represents the estimated exit price the Company would pay to terminate the agreement.

Note 10. Commitments

On November 4, 2011, the Company entered into an agreement with a vendor to purchase a minimum quantity of phones each year for the next three years. Under the terms of the agreement, among other things, the Company is required to purchase approximately 36,000 phones in addition to spending at least \$200,000 per year for the next three years on eligible merchandising expenses related to the phones.

As of December 31, 2011, the minimum amounts due related to the purchase of the phones approximated the following:

2012	\$ 6,500,000
2013	7,800,000
2014	<u>9,360,000</u>
	<u>\$ 23,660,000</u>

On September 22, 2011, the Company entered into an agreement with Verizon Wireless ("Verizon") to construct and operate its Long Term Evolution ("LTE") technology in geographic territories in the Company's market. Under the terms of the agreement, among other things, the Company is required as part of the initial build-out phase to have the cell sites constructed and fully equipped for provision of LTE Service and ready to commence commercial service no later than December 31, 2013. Following the initial build-out phase, the Company will continue to build out its LTE System in accordance with a plan to be mutually agreed by the Company and Verizon. The estimated cost of the initial build-out is approximately \$12,000,000. The agreement expires on June 13, 2019 with an option for a ten year renewal term at the end of the agreement.

In addition, the Company entered into an agreement to lease the spectrum owned by Verizon in order to offer LTE Service. This agreement also expires on June 13, 2019 with an option for a ten year renewal term at the end of the agreement. The lease expense is expected to be approximately \$300,000 per year



Jones, Nale & Mattingly PLC

**INDEPENDENT AUDITOR'S REPORT ON
THE SUPPLEMENTARY INFORMATION**

To the Members
East Kentucky Network, LLC
dba Appalachian Wireless
Prestonsburg, Kentucky 41653

Our audit was made for the purpose of forming an opinion on the basic financial statements taken as a whole. The supplementary information shown on pages 17 and 18 is presented for purposes of additional analysis and is not a required part of the basic financial statements. Such information is the responsibility of management and was derived from and relates directly to the underlying accounting and other records used to prepare the basic financial statements. The information has been subjected to the auditing procedures applied in the audit of the basic financial statements and certain additional procedures, including comparing and reconciling such information directly to the underlying accounting and other records used to prepare the basic financial statements or to the basic financial statements themselves, and other additional procedures in accordance with auditing standards generally accepted in the United States of America. In our opinion, the information is fairly stated in all material respects in relation to the financial statements taken as a whole.

Jones, Nale & Mattingly P.C.

Louisville, Kentucky
February 15, 2012

**EAST KENTUCKY NETWORK, LLC
DBA APPALACHIAN WIRELESS**

STATEMENTS OF INCOME DETAIL

	Year Ended December 31, 2011				
	RSA #9 Appalachian	RSA #10 Mountaineer	Fiber Ring	PCS	Totals
REVENUE					
Retail	\$31,312,192	\$ 19,759,349	\$ --	\$ 3,202,644	\$54,274,185
Roamer	16,919,770	5,798,853	--	379,521	23,098,144
Long distance	83,066	41,245	--	2,806	127,117
Paging	185,126	139,936	--	--	325,062
Equipment sales, cellular	1,591,322	870,986	--	194,359	2,656,667
Equipment sales, paging	21,833	12,415	--	--	34,248
Other	1,447,143	721,487	995,032	311,316	3,474,978
Total revenue	<u>\$51,560,452</u>	<u>\$ 27,344,271</u>	<u>\$ 995,032</u>	<u>\$ 4,090,646</u>	<u>\$83,990,401</u>
EXPENSES					
Cost of cellular service	\$10,236,676	\$ 6,289,107	\$ --	\$ 735,457	\$17,261,240
Cost of paging service	124,339	167,275	--	--	291,614
Cost of equipment sales, cellular	8,324,786	5,308,875	--	1,060,559	14,694,220
Cost of equipment sales, paging	14,284	9,313	--	--	23,597
Customer service	970,595	603,901	--	50,082	1,624,578
Billing	1,117,986	676,319	--	67,456	1,861,761
Selling	3,276,883	2,414,482	--	122,927	5,814,292
Maintenance	1,836,543	1,025,755	35,451	168,083	3,065,832
Utilities	595,520	377,399	55,554	89,082	1,117,555
Bad debts	758,637	259,313	--	65,620	1,083,570
Cell site rental	120,061	134,349	--	118,256	372,666
Taxes and licenses	524,438	239,436	73,464	27,332	864,670
Advertising	2,678,681	1,397,417	--	245,934	4,322,032
General and administrative	2,520,839	1,557,592	133,587	145,422	4,357,440
Occupancy	167,156	77,977	256,326	26,530	527,989
Depreciation	4,868,922	3,587,487	555,860	838,899	9,851,168
Amortization	314,413	461,343	11,841	91,900	879,497
Total expenses	<u>\$38,450,759</u>	<u>\$ 24,587,340</u>	<u>\$ 1,122,083</u>	<u>\$ 3,853,539</u>	<u>\$68,013,721</u>
Income (loss) from operations	<u>\$13,109,693</u>	<u>\$ 2,756,931</u>	<u>\$ (127,051)</u>	<u>\$ 237,107</u>	<u>\$15,976,680</u>
OTHER INCOME (EXPENSE)					
Interest income	\$ 17,634	\$ 10,966	\$ 294	\$ 880	\$ 29,774
Interest expense	(555,585)	(342,505)	--	(30,235)	(928,325)
Universal Service Fund income	4,751,960	2,930,376	--	237,598	7,919,934
	<u>\$ 4,214,009</u>	<u>\$ 2,598,837</u>	<u>\$ 294</u>	<u>\$ 208,243</u>	<u>\$ 7,021,383</u>
Net income (loss)	<u>\$17,323,702</u>	<u>\$ 5,355,768</u>	<u>\$ (126,757)</u>	<u>\$ 445,350</u>	<u>\$22,998,063</u>

Year Ended December 31, 2010

RSA #9 Appalachian	RSA #10 Mountaineer	Fiber Ring	PCS	Totals
\$28,516,088	\$18,608,730	\$ --	\$ 2,636,779	\$49,761,597
14,372,616	5,316,604	--	210,508	19,899,728
92,563	54,734	--	3,616	150,913
212,693	189,624	--	--	402,317
1,863,357	1,101,401	--	229,449	3,194,207
42,860	20,495	--	--	63,355
<u>1,169,305</u>	<u>416,598</u>	<u>1,190,037</u>	<u>199,450</u>	<u>2,975,390</u>
<u>\$46,269,482</u>	<u>\$25,708,186</u>	<u>\$ 1,190,037</u>	<u>\$ 3,279,802</u>	<u>\$76,447,507</u>
\$ 8,512,908	\$ 5,578,093	\$ --	\$ 768,400	\$14,859,401
158,209	203,584	--	--	361,793
8,391,841	5,367,426	--	964,728	14,723,995
22,557	12,555	--	--	35,112
895,223	544,787	--	42,302	1,482,312
1,044,865	627,728	--	58,038	1,730,631
2,647,610	2,256,284	--	90,253	4,994,147
1,615,022	1,021,661	130,643	121,239	2,888,565
545,559	341,686	20,129	69,156	976,530
563,697	196,757	--	(28,164)	732,290
108,399	109,517	--	76,254	294,170
1,422,683	430,903	106,078	66,764	2,026,428
2,530,129	1,197,994	--	172,408	3,900,531
2,475,958	1,486,341	137,092	121,052	4,220,443
159,369	83,443	302,048	29,465	574,325
4,852,676	3,707,164	570,350	678,346	9,808,536
299,000	451,667	15,050	86,821	852,538
<u>\$36,245,705</u>	<u>\$23,617,590</u>	<u>\$ 1,281,390</u>	<u>\$ 3,317,062</u>	<u>\$64,461,747</u>
<u>\$10,023,777</u>	<u>\$ 2,090,596</u>	<u>\$ (91,353)</u>	<u>\$ (37,260)</u>	<u>\$11,985,760</u>
\$ 14,718	\$ 9,498	\$ 340	\$ 722	\$ 25,278
(623,650)	(374,376)	--	(30,347)	(1,028,373)
<u>4,422,662</u>	<u>2,727,308</u>	<u>--</u>	<u>221,133</u>	<u>7,371,103</u>
<u>\$ 3,813,730</u>	<u>\$ 2,362,430</u>	<u>\$ 340</u>	<u>\$ 191,508</u>	<u>\$ 6,368,008</u>
<u>\$13,837,507</u>	<u>\$ 4,453,026</u>	<u>\$ (91,013)</u>	<u>\$ 154,248</u>	<u>\$18,353,768</u>

**EAST KENTUCKY NETWORK, LLC
DBA APPALACHIAN WIRELESS**

STATEMENTS OF INCOME DETAIL (Continued)

	Year Ended December 31, 2011				
	RSA #9 Appalachian	RSA #10 Mountaineer	Fiber Ring	PCS	Totals
COST OF CELLULAR SERVICE					
Roamer pass through charges	\$ 6,816,542	\$ 4,399,137	\$ --	\$ 631,778	\$11,847,457
SCB interconnection	676,267	437,079	--	42,526	1,155,872
Local charges	2,440,298	1,471,954	--	129,386	4,041,638
Harold interconnection	184,527	--	--	--	184,527
Wheelwright interconnection	54,515	--	--	--	54,515
GTE interconnection	148,505	133,237	--	--	281,742
West Liberty interconnection	182,700	--	--	--	182,700
Chapman interconnection	116,428	--	--	--	116,428
Salyersville interconnection	269,914	--	--	--	269,914
Roanoke interconnection	--	--	--	--	--
Interconnect revenue	(848,387)	(549,469)	--	(72,066)	(1,469,922)
Fiber ring interconnection	178,540	130,230	--	3,833	312,603
TGTC interconnection and DS3 charges	--	115,510	--	--	115,510
PRTC interconnection	--	151,429	--	--	151,429
West Virginia interconnection	16,827	--	--	--	16,827
	<u>\$10,236,676</u>	<u>\$ 6,289,107</u>	<u>\$ --</u>	<u>\$ 735,457</u>	<u>\$17,261,240</u>
COST OF PAGING SERVICE					
Paging maintenance	\$ 9,298	\$ 11,583	\$ --	\$ --	\$ 20,881
Salaries and benefits	37,457	56,186	--	--	93,643
Tower rent	24,235	41,488	--	--	65,723
Telephone expense	--	608	--	--	608
Expanded coverage costs	--	1,186	--	--	1,186
Interconnection charges	40,482	38,500	--	--	78,982
Office and billing expense	12,485	8,185	--	--	20,670
Other	382	9,539	--	--	9,921
	<u>\$ 124,339</u>	<u>\$ 167,275</u>	<u>\$ --</u>	<u>\$ --</u>	<u>\$ 291,614</u>

Year Ended December 31, 2010

RSA #9 Appalachian	RSA #10 Mountaineer	Fiber Ring	PCS	Totals
\$ 5,486,315	\$ 3,797,905	\$ --	\$ 648,658	\$ 9,932,878
589,908	372,352	--	27,572	989,832
2,271,654	1,349,384	--	117,444	3,738,482
153,713	--	--	--	153,713
45,875	--	--	--	45,875
146,541	129,187	--	33,012	308,740
174,193	--	--	--	174,193
106,469	--	--	--	106,469
275,026	--	--	--	275,026
8,459	--	--	--	8,459
(840,926)	(543,483)	--	(61,596)	(1,446,005)
78,439	134,840	--	3,310	216,589
--	168,547	--	--	168,547
--	169,361	--	--	169,361
17,242	--	--	--	17,242
<u>\$ 8,512,908</u>	<u>\$ 5,578,093</u>	<u>\$ --</u>	<u>\$ 768,400</u>	<u>\$14,859,401</u>
\$ 14,691	\$ 22,037	\$ --	\$ --	\$ 36,728
35,998	53,997	--	--	89,995
37,605	54,402	--	--	92,007
--	514	--	--	514
--	1,095	--	--	1,095
37,332	35,978	--	--	73,310
28,362	21,870	--	--	50,232
4,221	13,691	--	--	17,912
<u>\$ 158,209</u>	<u>\$ 203,584</u>	<u>\$ --</u>	<u>\$ --</u>	<u>\$ 361,793</u>

Directions to David Site

From the Floyd County Courthouse take Court Street .02 Miles to South Lake Drive. Take South Lake Drive .2 Miles to the Jct. of South Lake Drive and 114. Turn left onto 114 and continue for 2.9 miles to Route 404. Turn Left onto Route 404 and go 4.8 miles to C Nelson Drive. Turn right onto C Nelson Drive and continue to new gravel road (sign is posted at this point) Take new gravel road up the hill .6 miles to site. Sign is posted at location.

Directions were written by,

Marty Thacker
Appalachian Wireless
606-438-2355 Ext 111 (office)
606-634-9505 (Cell Phone)
m.thacker@tgtel.com (email)

Search Area Map

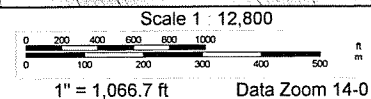
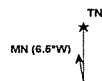
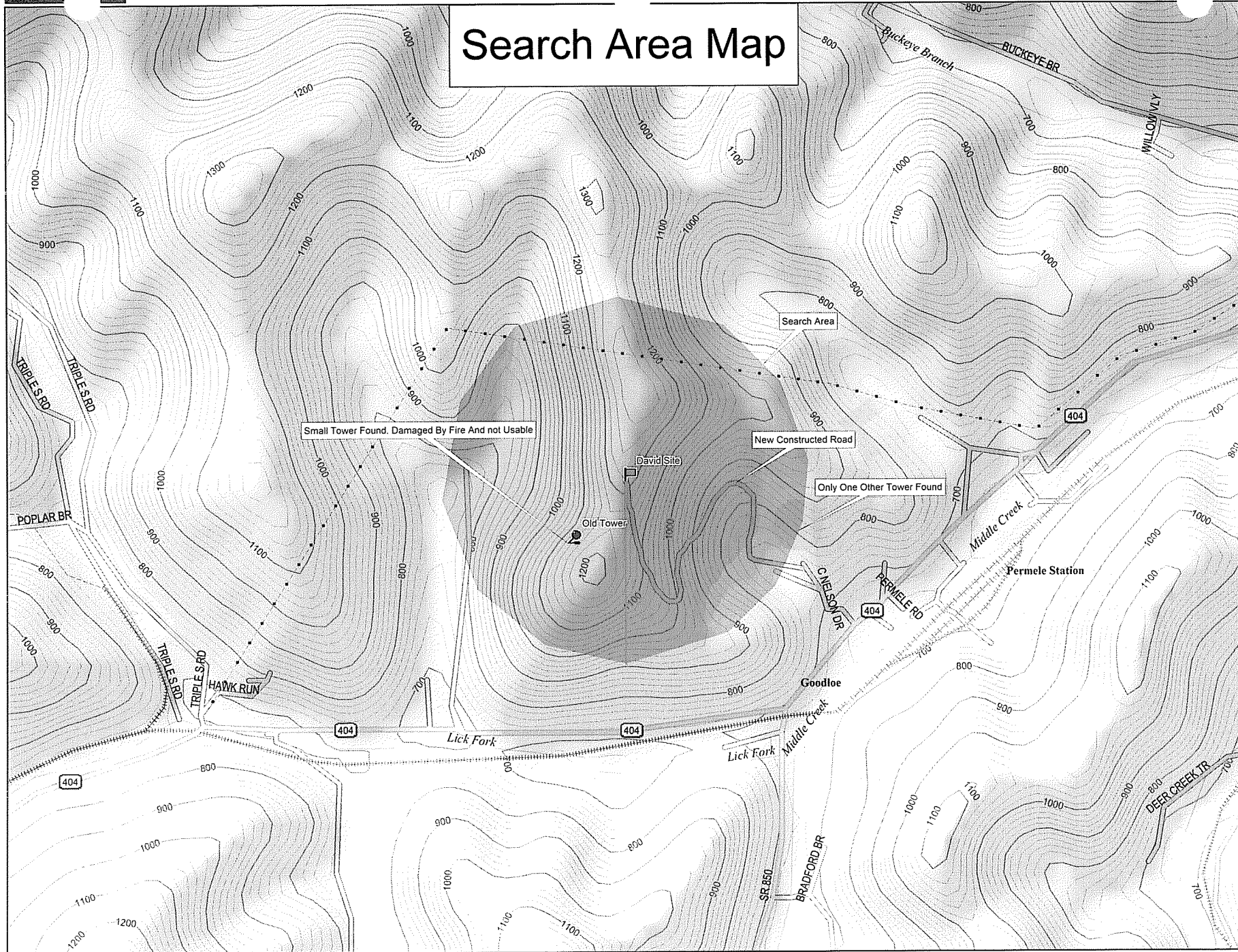

LEASE AGREEMENT

COPY

THIS LEASE AGREEMENT is made and entered into on the 16th day of March, 2012, with an effective date of April 1, 2012, by and between **Charlie Nelson and wife, Ruth Ann Nelson**, of 76 C Nelson Drive, David, KY 41616, **LESSORS**, and **East Kentucky Network, LLC, d/b/a Appalachian Wireless**, of 101 Technology Trail, Ivel, Kentucky 41642, **LESSEE**:

WITNESSETH:

That for and in consideration of the rents and other considerations hereinafter set out and subject to the terms and conditions therefore, Lessor(s) do hereby lease, let and demise unto Lessee, its successors and assigns, to have and to hold for the term hereinafter set out and subject to the Lessees right to surrender or terminate this Lease and provided hereinafter, the following described premises (Leased Premises), which term shall include all real property, rights and privileges herein granted:

BEING the same property described by metes and bounds in the description attached hereto and made a part hereof as Exhibit "A", and as shown on the plat dated March 6, 2012, prepared by Kenneth W. Johnson, Licensed Professional Land Surveyor, and attached hereto and made a part hereof as Exhibit "B" & "C".

The Lessor grants unto Lessee full and complete right of ingress, egress and regress over roads located upon this property controlled by Lessor to and from the Leased Premises, and the nonexclusive right to use any existing road located on this property. In the event the Lessee desires to relocate all or any portion of an existing roadway or to construct another access road to the Leased Premises, the location of such roadway shall be mutually agreed upon by Lessor and Lessee. Lessor further grants to the Lessee a right of way and easement to construct and maintain and operate telephone and power transmission lines over Lessors remaining property to the Leased Premises for service of the tower and related facilities only, said lines to be located

where feasible along the access road to the Leased Premises, with Lessor having input as to location of said power transmission lines in the event Lessee changes the location of its access road. Lessee shall have the right to trim or remove trees, limbs or underbrush which interferes with its access road or power/telephone lines wherever such road and lines are located or may damage tower if they fall. Lessee shall maintain the existing road with gravel and needed repairs.

This Lease is made on the following terms and conditions:

1. **TERM OF LEASE.** The term of this lease shall be for a period of thirty-five (35) years from the effective date.

2. **CANCELLATION.** Lessee shall have the right to terminate this Lease and abandon the Premises at any time under its sole discretion, upon six (6) month written notice to Lessor of its intention to do so. In the event that Leased Premises fail the process for approval as an acceptable cellular tower site by the Federal Communications Commission or any tests or requirements as required for such approval (the "FCC Process") or approval by the Public Service Commission of Kentucky (the "PSC"), or any other regulatory approval required, then in its sole discretion Lessor may terminate this Lease Agreement upon thirty (30) days written notice to Lessor of such intention. In the event of termination by Lessee, the Lessor shall have no obligation to refund all or any portion of the Leasehold rental payment that has been paid through the date of termination. Upon termination of this Lease, Lessee shall have one hundred eight (180) days thereafter to remove all structures it has erected upon the Leased Premises, and to reclaim the premises. Payment shall continue until said structures are removed.

3. **RENTAL.** As rental for the Leased Premises, Lessee shall pay Lessor \$400.00 per month with an increase of 5% added to the rental payment every five years. Please see table below for scheduled rent payments. If East Kentucky Network, LLC rents space on the tower located at this site to any other carrier, then the Lessors will be paid Ten Percent (10%) of the rent that East Kentucky Network, LLC collects. This will be in addition to the regular rent paid to the Lessors.

<u>YEARS</u>	<u>AMOUNT</u>
1-5	\$400.00
6-10	\$420.00
11-15	\$441.00
16-20	\$463.05
21-25	\$486.20
26-30	\$510.51
31-35	\$536.04

4. **USE OF PREMISES.** Lessee shall have the exclusive rights and privileges of the use of the Leased Premises for the purpose of constructing a tower, buildings, and other related facilities, including, but not limited to telephone lines, coaxial lines, power lines and the installation of any and all other equipment deemed necessary by Lessee to receive and transmit any and all electronic signals in the rural service area now or hereafter to be served by the facility. The parties hereto recognize that technology in the communications field is advancing at a rapid rate and that this site may be used for any other purpose now in the development stage or which may later be developed in the communications industry to carry out the objectives of Lessee, that being to transmit and receive signals and communications by wire, fiber optics, radio and satellite. Lessee shall not use the Leased Premises for purposes other than maintenance or use as a site for communications by the use of methods now or hereafter known.

Lessee agrees to maintain the Leased Premises in a neat and orderly manner.

5. **INDEMNITY.** Lessee agrees to indemnify and save harmless the Lessor from any liability by virtue of Lessee's activities upon the Leased Premises or in the exercise of any rights and privileges granted herein, specifically including but not limited to any claim, loss, fine, penalty and costs (including reasonable attorney's fees) arising out of any violation of any environmental laws or regulations. This provision shall survive the termination of the lease. Lessee shall maintain and keep in full force and effect public liability and property damage insurance in an amount of at least One Million Dollars (\$1,000,000.00). Lessor shall not be held liable for personal injury or property damage on the Leased Premises whether or not associated with Lessee.

6. **TAXES.** Lessee shall pay all personal property taxes assessed on or any portion of such taxes attributable to the equipment used by Lessee on the Premises. Lessor shall pay when due all real property taxes and all other fees and assessments attributable to the Premises. Lessee shall reimburse the Lessor as additional compensation for any increase in real estate taxes levied against the Lessor (or its successors or assigns) which are directly attributable to or arise as a result of the improvements constructed by the Lessee, its successors or assigns. Payment will be issued after Lessee receives written proof from Lessor that the increase in real estate taxes levied is due to improvements constructed by the Lessee.

7. **MISCELLANEOUS PROVISIONS.** All notices, demands, or other writings in this Lease Agreement provided to be given, made or sent, or which may be given or made or sent, to either party hereto to the other, shall be deemed to have been fully given or made or sent when made in writing and deposited in the United States Mail, certified and postage prepaid, to Lessor and Lessee at the addresses stated in the caption of this Lease Agreement. Such addresses may be changed by written notice given by such party as above provided.

8. **SUCCESSORS AND ASSIGNS.** This Lease Agreement shall be binding upon the parties hereto, their heirs, executors, administrators and assigns.

WITNESS OUR HANDS, the day and year aforesaid.

LESSORS:

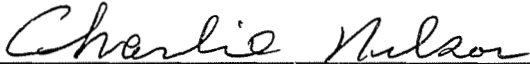

Charlie Nelson

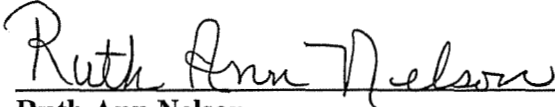

Ruth Ann Nelson

LESSEE:

EAST KENTUCKY NETWORK, LLC

d/b/a APPALACHIAN WIRELESS

BY: Gerald F. Robinette

ITS: General Manager

STATE OF Kentucky

COUNTY OF Floyd

The foregoing Lease Agreement was this 16th day of March, 2012, produced and acknowledged before me by **Charlie and Ruth Ann Nelson**, his Wife, Lessors.

Lynn Haney

NOTARY PUBLIC

My Commission Expires
July 14, 2015

COMMISSION EXPIRES: _____

STATE OF KENTUCKY

COUNTY OF Floyd

The foregoing Lease Agreement was this 16th day of March, 2012, produced and acknowledged before me by **East Kentucky Network, LLC, dba Appalachian Wireless** by Gerald F. Robinette, its General Manager, Lessee.

Lynne Haney

NOTARY PUBLIC

**My Commission Expires
July 14, 2015**

COMMISSION EXPIRES: _____

Exhibit A

DESCRIPTION OF
A 0.237 ACRE TRACT FOR
APPALACHIAN WIRELESS

Being part of a certain tract of land lying on Middle Creek at David in Floyd County, Kentucky. Being a part of the tract conveyed to Charles Nelson and Ruth Ann Nelson at Deed Book 202, Page 117 and Deed Book 389, Page 757 in the Floyd County Court Clerk's Office and described as follows:

Monuments referred to herein as iron pin (set) is a 5/8 inch rebar, with a plastic cap stamped Johnson PLS 3325. The Basis of Bearings is the Kentucky South 1983 NAD coordinate system.

Beginning at an iron pin (set) on the center of the ridge, witnessed by the center of Kentucky Highway 404 and C Nelson Drive at south 61 degrees 10 minutes 09 seconds east, 2200 feet, being the True Point of Beginning;

Thence continuing along said ridge North 10 degrees 04 minutes 17 seconds East, 99.93 feet to an iron pin (set);

Thence leaving said ridge South 75 degrees 35 minutes 28 seconds East, 108.45 feet to an iron pin (set);

Thence South 14 degrees 31 minutes 52 seconds West, 99.75 feet to an iron pin (set);

Thence North 75 degrees 32 minutes 04 seconds West, 100.68 feet to the True Point of Beginning containing 0.237 acres.

Survey performed by Kenneth W. Johnson, PLS #3325 on February 13, 2012.

Kenneth W. Johnson
2/13/12

STATE OF KENTUCKY
KENNETH W.
JOHNSON
3325
LICENSED
PROFESSIONAL
LAND SURVEYOR

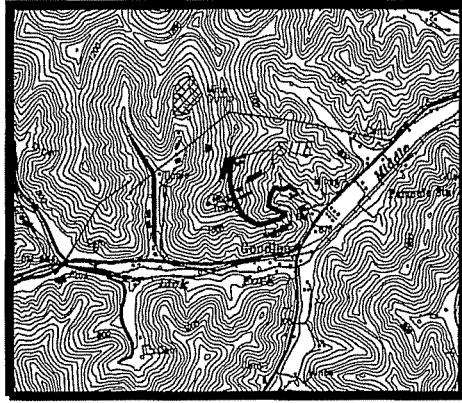

CLASS B SURVEY (RURAL)
 METHOD: RANDOM TRAVERSE
 INSTRUMENT: NIKON TOTAL STATION
 AND CARLSON DATA COLLECTOR.
 CLOSURE: 1"=18180'

- THIS SURVEY WAS PERFORMED WITHOUT THE BENEFIT OF TITLE WORK.
- SUBJECT TO ALL EASEMENTS AND RIGHT-OF-WAY RECORDED OR UNRECORDED.
- PROPERTY LOCATED IN DAVID, KENTUCKY.
- IRON PINS (set) DENOTES A 5/8" REBAR WITH A PLASTIC CAP STAMPED JOHNSON PLS 3325.
- CURRENT DEED INFORMATION ACQUIRED FROM COUNTY PVA OFFICE.
- LAST DATE OF FIELD WORK 02-09-12.
- UTILITIES NOT SHOWN AS A PART OF THIS SURVEY.
- THE BASIS OF BEARINGS FOR THIS SURVEY IS THE KENTUCKY STATE PLANE COORDINATES FROM A GEOTRACER STATIC GPS, POST PROCESSED WITH TRIMBLE TOTAL CONTROL SOFTWARE, KENTUCKY SOUTH NAD 1983.
- THIS SURVEY WAS PERFORMED BY KENNETH W. JOHNSON AS AN EMPLOYEE OF COLEMAN ENGINEERING.
- DESCRIPTION PREPARED ON SEPARATE SHEET
- ACCESS ROAD SHOWN ON SECOND SHEET.

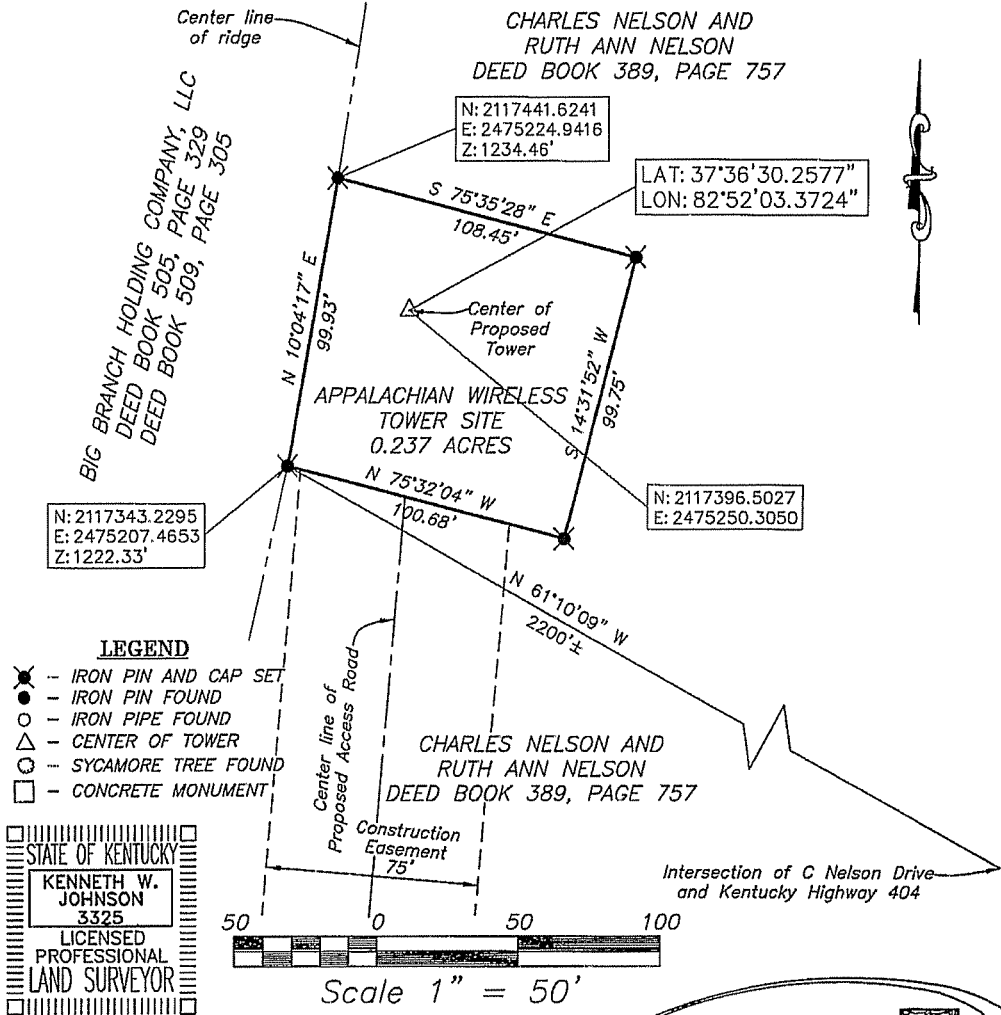

- LEGEND**
- ✱ - IRON PIN AND CAP SET
 - - IRON PIN FOUND
 - - IRON PIPE FOUND
 - △ - CENTER OF TOWER
 - - SYCAMORE TREE FOUND
 - - CONCRETE MONUMENT

STATE OF KENTUCKY
 KENNETH W. JOHNSON
 3325
 LICENSED PROFESSIONAL LAND SURVEYOR

SURVEYOR'S CERTIFICATE
 I hereby certify that this plat and survey were made under my direct supervision and that the angular and linear measurements, as witnessed by the monuments shown hereon, are true and correct to the best of my knowledge and belief.

Kenneth W. Johnson 3-6-12
 Kenneth W. Johnson P.L.S. #3325

COLEMAN ENGINEERING

P.O. BOX 153 HINDMAN, KENTUCKY 41822

SURVEY FOR APPALACHIAN WIRELESS 101 Technology Trail lvel, Kentucky 41642		KENNETH W. JOHNSON LAND SURVEYING 356 CHESTNUTLOG BR. RD. P.O. BOX 269 FISTY, KENTUCKY 41743 (606)251-3814		EXHIBIT 1 OF 2
SCALE: 1"=50'	DATE: 03-06-12	DRAWN: KWJ	CHECKED: RLC	APPROVED: KWJ
BEING A PART OF THE TRACT OF LAND LYING ON MIDDLE CREEK AT DAVID IN FLOYD COUNTY KENTUCKY, BEING A PART OF THE SAME TRACT CONVEYED TO CHARLES NELSON AND RUTH ANN NELSON AT DEED BOOK 202, PAGE 117 AND DEED BOOK 389, PAGE 757 IN THE COUNTY COURT CLERKS OFFICE OF FLOYD COUNTY, KENTUCKY				
JOB No. DAVID				

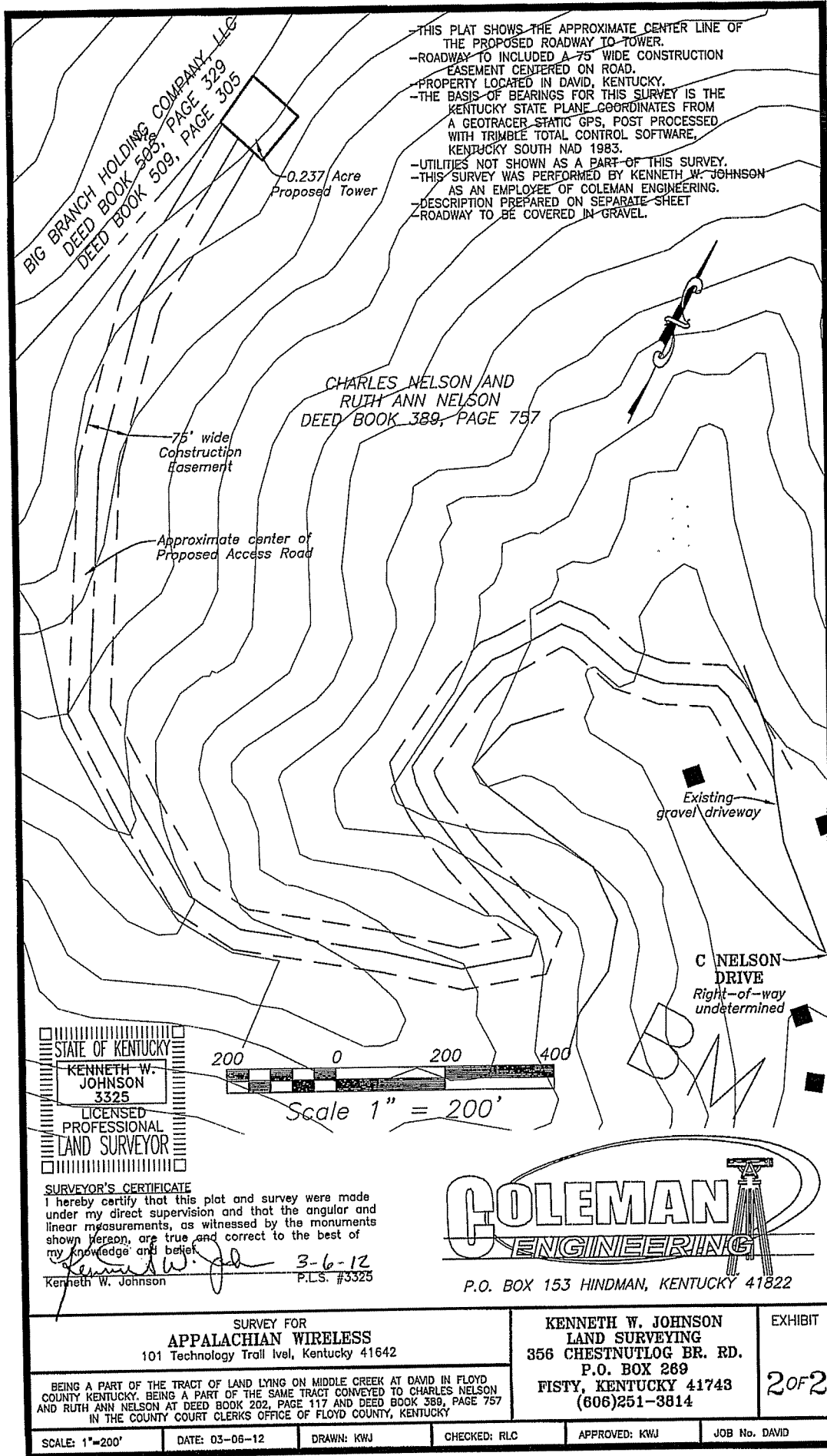

- THIS PLAT SHOWS THE APPROXIMATE CENTER LINE OF THE PROPOSED ROADWAY TO TOWER.
- ROADWAY TO INCLUDE A 75' WIDE CONSTRUCTION EASEMENT CENTERED ON ROAD.
- PROPERTY LOCATED IN DAVID, KENTUCKY.
- THE BASIS OF BEARINGS FOR THIS SURVEY IS THE KENTUCKY STATE PLANE COORDINATES FROM A GEOTRACER STATIC GPS, POST PROCESSED WITH TRIMBLE TOTAL CONTROL SOFTWARE, KENTUCKY SOUTH NAD 1983.
- UTILITIES NOT SHOWN AS A PART OF THIS SURVEY.
- THIS SURVEY WAS PERFORMED BY KENNETH W. JOHNSON AS AN EMPLOYEE OF COLEMAN ENGINEERING.
- DESCRIPTION PREPARED ON SEPARATE SHEET
- ROADWAY TO BE COVERED IN GRAVEL.

BIG BRANCH HOLDING COMPANY, LLC
 DEED BOOK 505, PAGE 329
 DEED BOOK 509, PAGE 305

0.237 Acre
 Proposed Tower

CHARLES NELSON AND
 RUTH ANN NELSON
 DEED BOOK 389, PAGE 757

75' wide
 Construction
 Easement

Approximate center of
 Proposed Access Road

Existing
 gravel driveway

C NELSON
 DRIVE
 Right-of-way
 undetermined

STATE OF KENTUCKY
 KENNETH W. JOHNSON
 3325
 LICENSED PROFESSIONAL
 LAND SURVEYOR



Scale 1" = 200'

SURVEYOR'S CERTIFICATE

I hereby certify that this plot and survey were made under my direct supervision and that the angular and linear measurements, as witnessed by the monuments shown hereon, are true and correct to the best of my knowledge and belief.

Kenneth W. Johnson 3-6-12
 Kenneth W. Johnson P.L.S. #3325

COLEMAN ENGINEERING

P.O. BOX 153 HINDMAN, KENTUCKY 41822

SURVEY FOR APPALACHIAN WIRELESS 101 Technology Trail Ivel, Kentucky 41642		KENNETH W. JOHNSON LAND SURVEYING 356 CHESTNUTLOG BR. RD. P.O. BOX 269 FISTY, KENTUCKY 41743 (606)251-3814	EXHIBIT 20f2
BEING A PART OF THE TRACT OF LAND LYING ON MIDDLE CREEK AT DAVID IN FLOYD COUNTY KENTUCKY. BEING A PART OF THE SAME TRACT CONVEYED TO CHARLES NELSON AND RUTH ANN NELSON AT DEED BOOK 202, PAGE 117 AND DEED BOOK 389, PAGE 757 IN THE COUNTY COURT CLERKS OFFICE OF FLOYD COUNTY, KENTUCKY			
SCALE: 1"=200'	DATE: 03-06-12	DRAWN: KWJ	CHECKED: RLC
APPROVED: KWJ		JOB No. DAVID	

CASE NO: 2012-00452

CONTAINS

LARGE OR OVERSIZED

MAP(S)

RECEIVED ON: February 6, 2013

MARTIN 7.5' QUADRANGLE

N: 2117441.6241
E: 2475224.9416
Z: 1234.46'

LINE	BEARING	DISTANCE
L1	S 65°04'22" E	40.55'
L2	S 32°22'41" E	35.11'
L3	S 28°10'57" E	13.24'
L4	S 01°07'47" E	42.20'
L5	N 18°02'34" E	59.11'
L6	N 24°47'26" E	38.96'
L7	N 27°49'16" E	77.73'
L8	N 43°52'34" E	70.45'
L9	N 50°54'28" E	49.80'

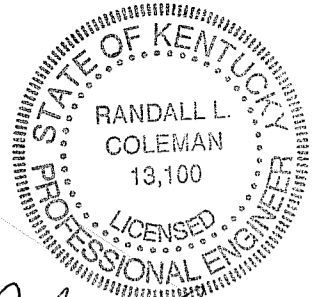

Randall L. Coleman

LAT: 37°36'30.4126"
LON: 82°52'03.4480"

N: 2117411.9736
E: 2475243.7425

CONCRETE FOUNDATION
FOR PROPOSED TOWER
BELOW GROUND

CONCRETE PAD FOR
BUILDING AND GENERATOR
ABOVE GROUND

APPALACHIAN WIRELESS

101 TECHNOLOGY TRAIL
MIDDEL, KENTUCKY 41642

PROPOSED TOWER SITE
CHARLES NELSON AND
ANN NELSON TRACT AT
DAVID IN FLOYD CO. KY.

DRAWN BY: KWJ
DATE: 12-14-12
JOB: DAVID
SCALE: 1"=10'

SEE FOUNDATION DRAWINGS FOR DETAILS.

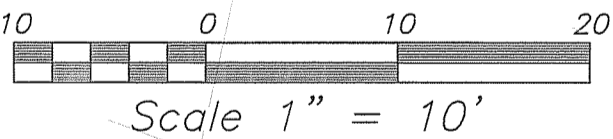

LEGEND

- TOWER
- IRON PIN SET
- ACCESS ROAD
- PROPERTY LINE

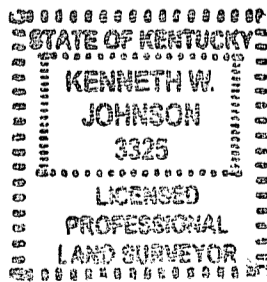
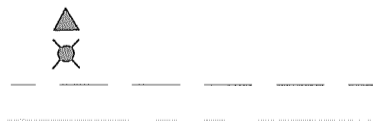

THE PROPOSED TOWER HAS BEEN LOCATED USING A GEORACER GTR 220 AND POST PROCESSED WITH TRIMBLE SOFTWARE. STATE PLANE COORDINATES NAD 83 KY SOUTH ZONE N 37°36'30.4126", E 82°52'03.4480" 1224 FT MSL PRECISION HORIZONTAL =0.30' VERTICAL =0.50' THIS SURVEY MEETS THE OBSTACLE ACCURACY CODE 1A.

SURVEYOR'S CERTIFICATE: I HEREBY CERTIFY THAT THIS DOCUMENT WAS PREPARED BY ME OR UNDER MY DIRECTIONS.

Kenneth W. Johnson
KENNETH W. JOHNSON P.L.S.#3325 DATE: 12-14-12

MAP SHOWING TOWER LAYOUT
AND STAKEOUT INFORMATION

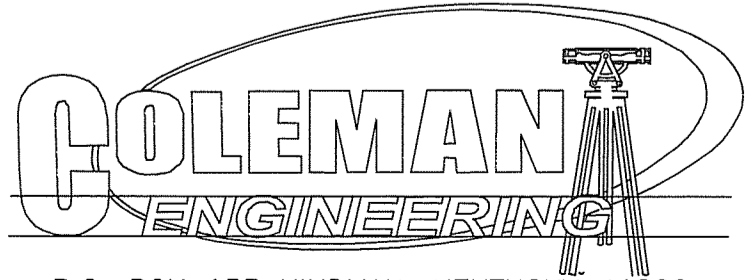

P.O. BOX 153 HINDMAN, KENTUCKY 41822

APPALACHIAN WIRELESS

101 TECHNOLOGY TRAIL
IVEL, KENTUCKY 41642

PROPOSED TOWER SITE
CHARLES NELSON AND
ANN NELSON TRACT AT
DAVID IN FLOYD COUNTY OF KENTUCKY

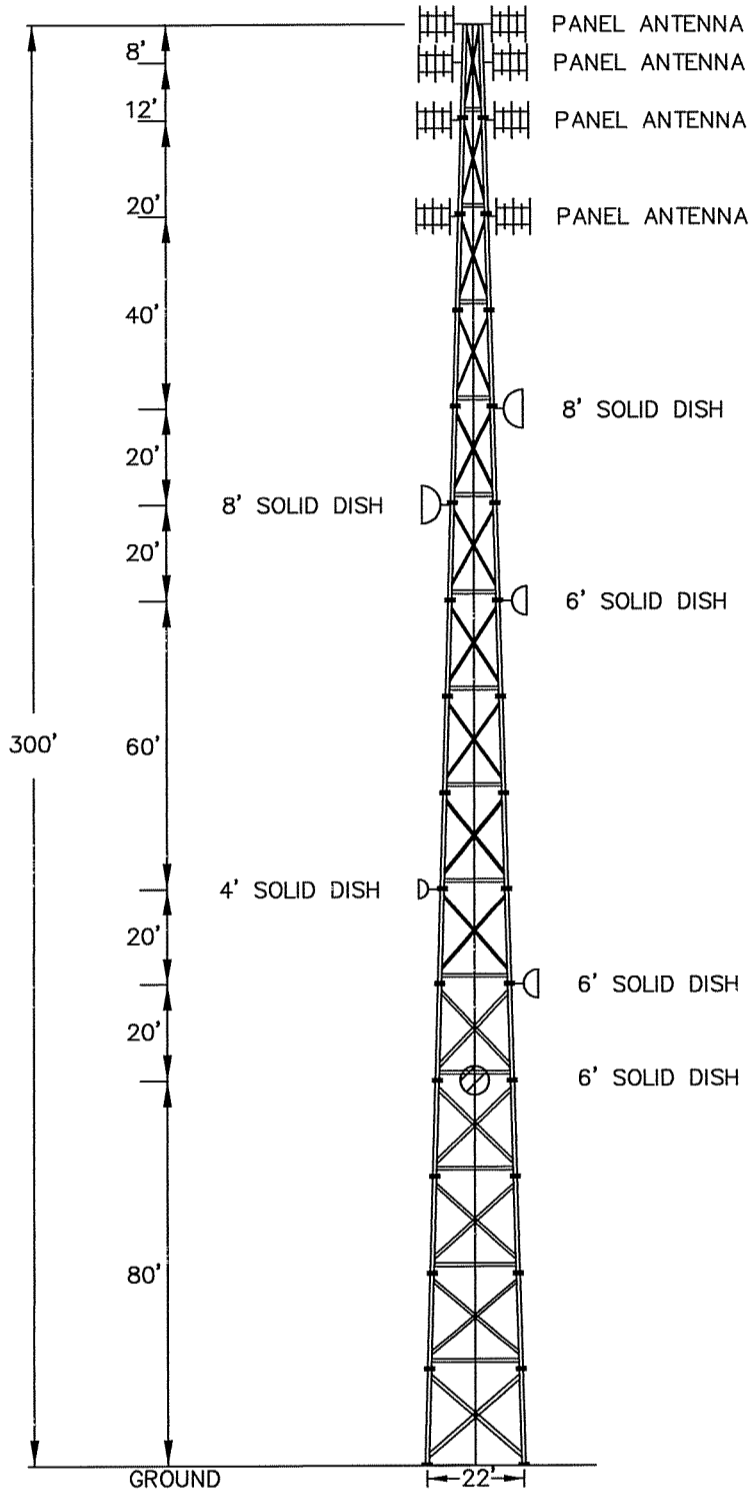
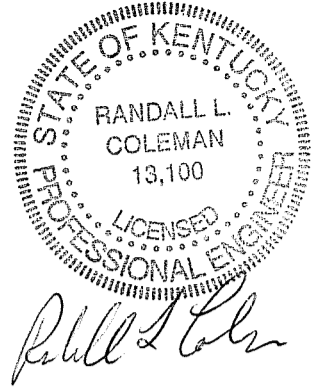

Scale 1" = 40'

STATE OF KENTUCKY
KENNETH W.
JOHNSON
3325
LICENSED
PROFESSIONAL
LAND SURVEYOR

DRAWN BY: KWJ
DATE: 12-14-12
JOB: DAVID
SCALE: 1"=40'

THIS IS A VERTICAL PROFILE SKETCH OF THE TOWER INDICATING THE PROPOSED ANTENNA AND DISH ELEVATIONS. NO DESIGN CRITERIA WAS CONSIDERED IN THE PREPARATION OF THIS DRAWING.

Kenneth W. Johnson
KENNETH W. JOHNSON P.L.S. #3325 DATE: 12-14-12

VERTICAL PROFILE SKETCH
DAVID TOWER SITE

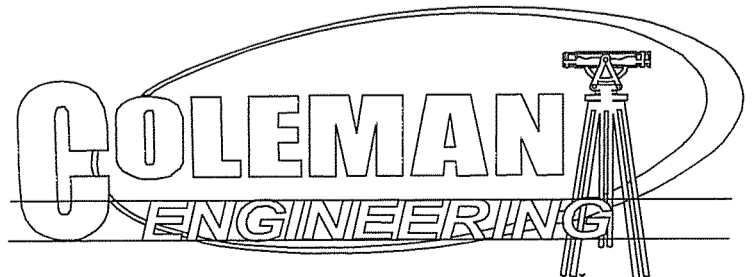

P.O. BOX 153 HINDMAN, KENTUCKY 41822